

Video Camera Recorder⁸

CCD-TR28/TR30

Operation Manual

Before operating the unit, please read this manual thoroughly and retain it for future reference.

Owner's Record

The model and serial numbers are located on the bottom. Record the serial number in the space provided below. Refer to these numbers whenever you call upon your Sony dealer regarding this product.

Model No. CCD-TR28/TR30 Serial No. _____

Model No. AC-V25/V25A Serial No. _____

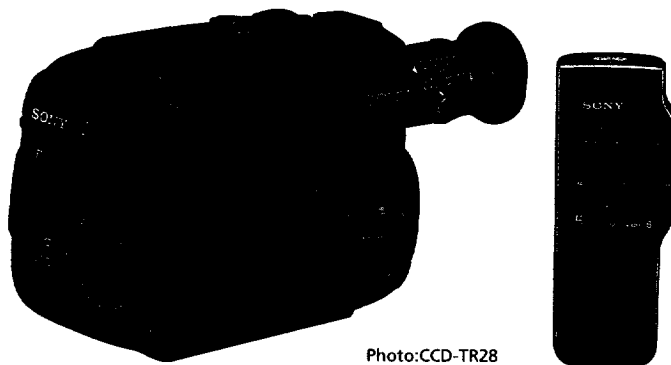

Photo:CCD-TR28

Video⁸ Handycam

©1994 by Sony Corporation

WARNING

To prevent fire or shock hazard, do not expose the unit to rain or moisture.

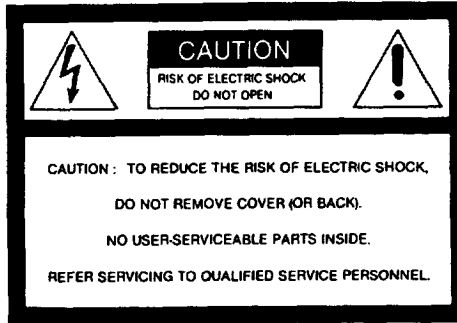

This symbol is intended to alert the user to the presence of uninsulated "dangerous voltage" within the product's enclosure that may be of sufficient magnitude to constitute a risk of electric shock to persons.



This symbol is intended to alert the user to the presence of important operating and maintenance (servicing) instructions in the literature accompanying the appliance.

RECYCLING NICKEL-CADMIUM BATTERIES



NICKEL-CADMIUM BATTERY. MUST BE DISPOSED OF PROPERLY.

Ni-Cd

Nickel-Cadmium batteries are recyclable. You can help preserve our environment by returning your unwanted batteries to your nearest Sony Service Center or Factory Service Center for collection, recycling or proper disposal.

Note: In some areas the disposal of nickel-cadmium batteries in household or business trash may be prohibited.

For the Sony Service Center nearest you call 1-800-222-SONY (United States only)
For the Factory Service Center nearest you call 416-499-SONY (Canada only)

Caution: Do not handle damaged or leaking nickel-cadmium batteries.

2

For the customers in the U.S.A.

WARNING

This equipment has been tested and found to comply with the limits for a Class B digital device, pursuant to Part 15 of the FCC Rules. These limits are designed to provide reasonable protection against harmful interference in a residential installation. This equipment generates, uses, and can radiate radio frequency energy and, if not installed and used in accordance with the instructions, may cause harmful interference to radio communications. However, there is no guarantee that interference will not occur in a particular installation if this equipment does cause harmful interference to radio or television reception, which can be determined by turning the equipment off and on, the user is encouraged to try to correct the interference by one or more of the following measures:

- Reorient or relocate the receiving antenna.
- Increase the separation between the equipment and receiver.
- Connect the equipment into an outlet on a circuit different from that to which the receiver is connected.
- Consult the dealer or an experienced radio/TV technician for help.

CAUTION

You are cautioned that any changes or modifications not expressly approved in this manual could void your authority to operate this equipment.

For the Customers in CANADA

Notice for the customers in Canada

This apparatus complies with the Class B limits for radio noise emissions set out in Radio Interference Regulations.

CAUTION

TO PREVENT ELECTRIC SHOCK, DO NOT USE THIS POLARIZED AC PLUG WITH AN EXTENSION CORD, RECEPTACLE OR OTHER OUTLET UNLESS THE BLADES CAN BE FULLY INSERTED TO PREVENT BLADE EXPOSURE.

Welcome to Video 8

Congratulations on your purchase of this Sony Handycam® camcorder. With your Handycam you can capture life's precious moments with superior picture and sound quality. Your Handycam is loaded with advanced features, but at the same time it is very easy to use. You will soon be producing home video that you can enjoy for years to come.

Table of Contents

Before You Begin

- About This Manual 4
- Checking Supplied Accessories 5

Getting Started

- Charging and Installing the Battery Pack 6
- Tips for Using the Battery Pack 9
- Inserting a Cassette 12
- Adjusting the Viewfinder Lens 13
- Hints for Better Shooting 14

Basic Operations

- Camera Recording 15
 - Using the Zoom Feature 17
 - Recording the Date or Time 18
- Connections for Playback 19
 - Connecting to a TV without Audio/Video Input Jacks 19
 - Connecting to a TV or VCR with Audio/Video Input Jacks 19
- Playing Back a Tape 20

Advanced Operations

- Using Alternate Power Sources 21
 - Using House Current 21
- Editing onto Another Tape 23

Additional Information

- Changing the Lithium Battery 24
- Resetting the Date and Time 25
- Playback Modes 26
- Maintenance Information and Precautions 27
- Using Your Camcorder Abroad 31
- Identifying the Parts 32
 - Remote Commander 36
- Specifications 39
- Trouble Check 40
- Indicators in the Viewfinder 43
- Index (Back cover)

Before You Begin About This Manual

The instructions in this manual are for two models, CCD-TR28 and CCD-TR30. CCD-TR28 and CCD-TR30 are different in body color. The former is gray and the latter is black. There is no difference in function.

If you want to shoot as soon as possible, read the chapters "Getting Started" and "Basic Operations" first. As you read through this manual, buttons and settings on the camcorder are shown in capital letters.

e.g. Set the POWER switch to CAMERA.

Note on TV Color Systems

TV color systems differ from country to country. To view your recordings on a TV, you need an NTSC system based TV. When you want to use a PAL-M system based TV, you will need an NTSC/PAL-M transcoder (as this is an NTSC system based camcorder).

Please check the list on page 31 to see the TV color system of your country.

Note on the Supplied RFU Adaptor

Since each country has its own electricity and TV color system, you may not be able to use the RFU adaptor when you use the camcorder abroad.

Precaution on Copyright

Television programs, films, video tapes, and other materials may be copyrighted. Unauthorized recording of such materials may be contrary to the provision of the copyright laws.

Precautions on Camcorder Care

- Do not let sand get into the camcorder. When you use the camcorder on a sandy beach or dusty place, protect it from the sand or dust. Sand or dust may cause the unit to malfunction and sometimes the malfunction cannot be repaired. [a]
- Do not let the camcorder get wet. Keep the camcorder away from rain or sea water. It may cause the unit to malfunction and sometimes the malfunction cannot be repaired. [b]
- Never leave the camcorder under temperatures above 140°F (60°C), such as in a car parked in the sun or under direct sunlight. [c]

[a]

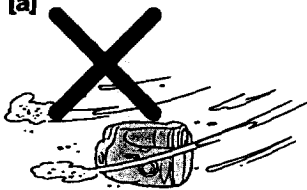

[b]



[c]

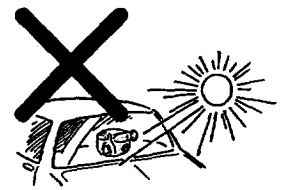

Checking Supplied Accessories

Check that the following accessories are supplied with your camcorder.

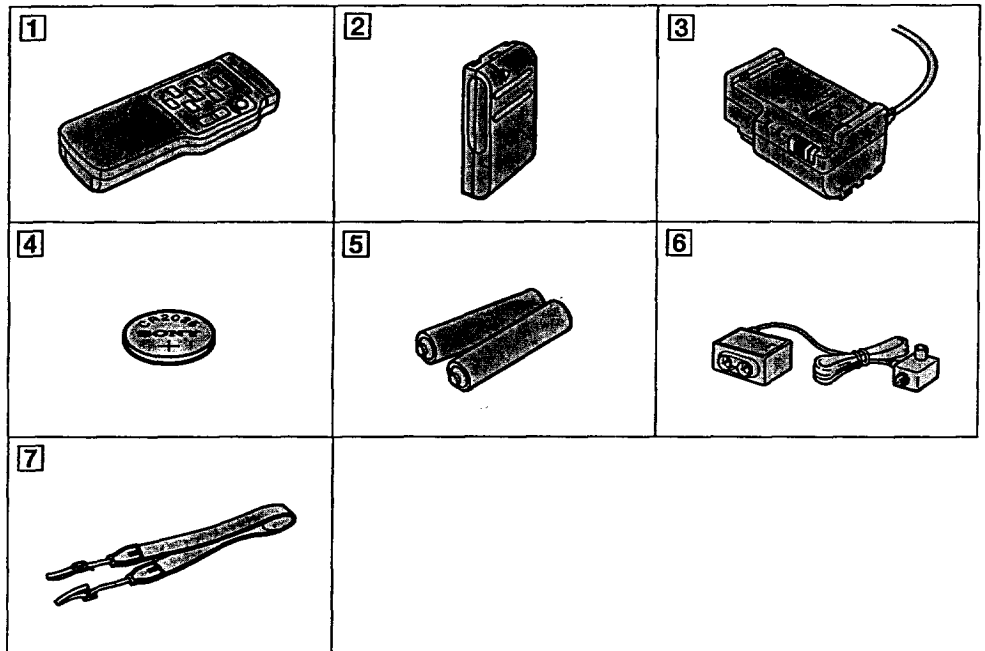

- 1 Wireless Remote Commander (1) (p. 36)
- 2 NP-55 Battery pack (1) (p. 6)
- 3 AC-V25/V25A AC power adaptor (1) (p. 6, 42)
- 4 CR2025 Lithium Battery (Installed in the camcorder) (1) (p. 24)
- 5 Size AA (R6) battery for Remote Commander (2) (p. 36)
- 6 RFU-95UC RFU adaptor (1) (p. 19)
- 7 Shoulder strap (1) (p. 38)

Getting Started

Charging and Installing the Battery Pack

Before using your camcorder, you first need to charge and install the battery pack. To charge the battery pack, use the supplied AC-V25/V25A AC power adaptor.

Charging the Battery Pack

Charge the battery pack on a flat place without vibration.

(1) Connect the power cord to a wall outlet. (2) Align the right side of the battery pack with the line on the AC power adaptor, then slide the battery pack in the direction of the arrow. (3) Set the selector to CHARGE. Charging begins.

When charging is completed, the CHARGE lamp goes out. Set the selector to the center position and unplug the unit from the wall outlet. Then remove the battery pack and install it on the camcorder. To stop charging, set the selector to the center position.

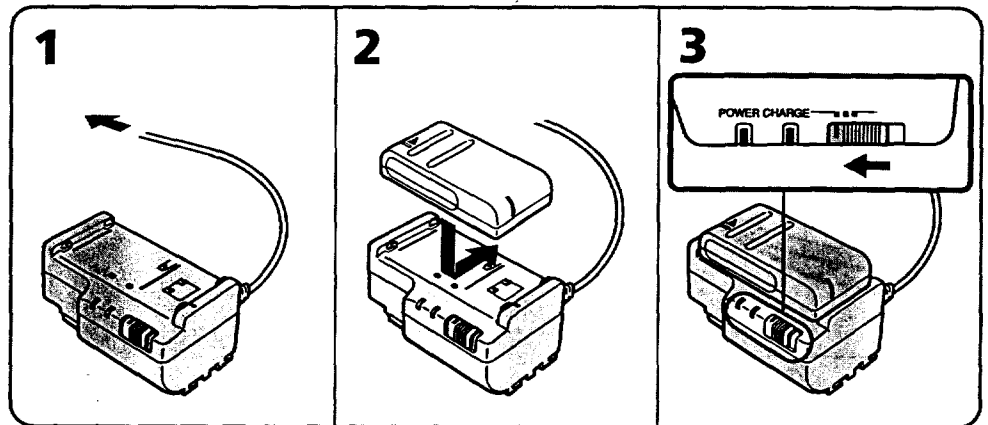

Charging Time and Battery Life

Battery pack	NP-55 (supplied)	NP-80 NP-80D	NP-77H	NP-66H	NP-60D	NP-55H
Charging time*	70	180	160	120	90	80
Typical recording time**	30	80	75	55	40	35
Continuous recording time***	60	160	150	110	80	70

* Approximate minutes to charge an empty battery pack using the AC-V25/V25A (Lower temperatures require a longer charging time.)

** Approximate minutes when recording while you repeat recording start/stop and turning the power on/off. The actual battery life may be shorter.

*** Approximate continuous recording time indoors.

Important!

Use the battery completely before re-charging!

Before you recharge the battery, make sure the battery has been used up (discharged) completely. Repeated charging while some capacity remains causes a lowering of battery capacity. However, the original battery capacity can be recovered if you use the battery completely and charge it fully again.

To use up the battery, remove the cassette and set the POWER switch to CAMERA with the battery attached, and leave the camcorder until the  indicator and the red lamp flash in the viewfinder.

Removing the Battery Pack

Slide the battery pack in the direction of the arrow (see drawing).

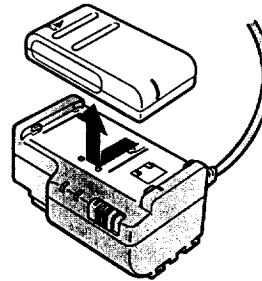

Note on charging the battery pack

- The POWER lamp will remain lit for a while even if the battery pack is removed and the power cord is unplugged after charging the battery pack. This is normal.
- If the POWER lamp does not light, set the selector to the center position and disconnect the power cord. After about one minute, reconnect the power cord and set the selector to CHARGE again.
- You cannot operate the camcorder using the AC power adaptor while charging the battery pack.

Charging and Installing the Battery Pack

Installing the Battery Pack

(1) Lift up the viewfinder. (2) Align the right side of the battery pack with the white line on the camcorder, and slide the battery pack to the right.

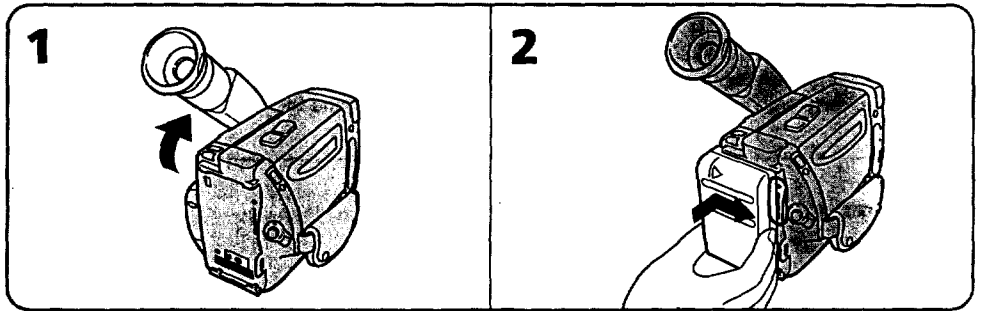

Removing the Battery Pack

(1) Lift up the viewfinder. (2) While pressing BATT, slide the battery pack to the left.

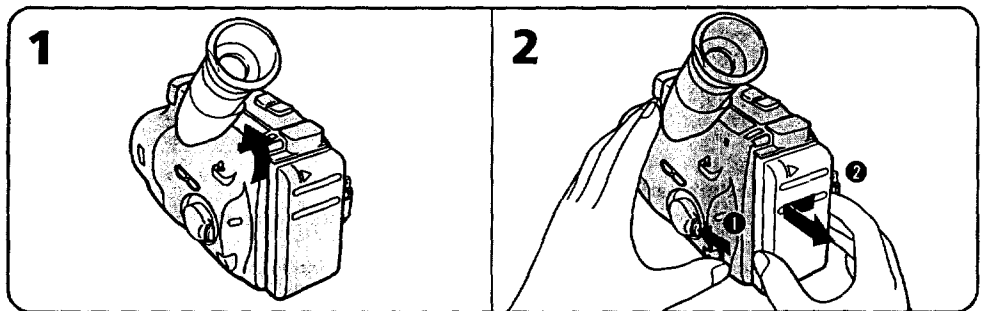

Tips for Using the Battery Pack

This section shows you how you can get the most out of your battery pack.

Preparing the Battery Pack

Always Carry Additional Batteries

Have sufficient battery pack power to do 2 to 3 times as much recording as you have planned.

Battery Life is Shorter in Cold Environment

Battery efficiency is decreased and the battery will be used up more quickly if you are recording in cold environment.

To Save Battery Power

Turn STANDBY on the camcorder down when not recording to save battery power. [a]

A smooth transition between scenes can be made even if recording is stopped and started again. While positioning the subject, selecting an angle, or looking through the viewfinder lens, the lens moves automatically and the battery is used. The battery is also used when a tape is inserted or removed.

When to Replace the Battery Pack

While you are using your camcorder, the remaining battery indicator decreases gradually as battery power is used up.



When the remaining battery indicator reaches the lowest point, the  indicator appears and starts flashing in the viewfinder. [b]

When the  indicator in the viewfinder changes from slow flashing to rapid flashing while you are recording, set the POWER switch to OFF on the camcorder and replace the battery pack. Leave the tape in the camcorder to obtain smooth transition between scenes after the battery pack is replaced.

Note on the remaining battery indicator

The remaining battery indicator of the camcorder may indicate a different remaining capacity from that of the battery pack with its own indicator (not supplied). The indicator of the battery pack is more accurate.

Tips for Using the Battery Pack

Note on the Rechargeable Battery Pack

The Battery Heats Up

During charging or recording, the battery pack heats up. This is caused by energy that has been generated and a chemical change that has occurred inside the battery pack. This is not cause for concern.

Battery Care

- Remove the battery pack from the camcorder after using the battery pack, and keep it in a cool place. When the battery pack is attached to the camcorder, a small amount of current flows to the camcorder even if the POWER switch is set to OFF, which shortens battery life.
- The battery pack is always discharging even when it is not in use after charging. Therefore, you should charge the battery right before using the camcorder.

How to Use the Switch on the Battery Pack

This switch is provided so that you can mark the charged battery. Set the switch to the "no mark" position when charging is completed. Set the switch to the "red mark" position when the battery is used up (or in whichever direction you want to remind yourself). [C]

The Life of the Battery Pack

The battery pack can be fully charged and discharged about 500 times under normal temperatures. If the battery indicator flashes rapidly just after turning on the camcorder with a fully charged battery pack, the battery pack should be replaced with a new fully charged one.

Charging Temperature

You should charge batteries at temperatures from 50°F to 86°F (from 10°C to 30°C). Lower temperatures require a longer charging time.

Note on Charging

A Brand-new Battery

A brand-new battery pack is not charged. Before using the battery pack, charge it completely.

Before Recharging a Used Battery Pack

- Make sure to use up the battery before recharging.
- If recording is completed before the  indicator appears in the viewfinder, you should remove the tape, set the POWER switch to CAMERA, turn STANDBY up, and leave the camcorder until the battery indicator flashes rapidly.
- When you use the AC-S10 power adaptor, the DC-S10 car battery charger or BC-S10 portable battery charger, you can use the discharging function.
- **Charging the usable battery causes a lowering of battery capacity. Battery capacity can be recovered if you fully discharge and charge the battery again.**

After Long Storage

Recharge the battery pack after a long period of storage. If the battery pack is charged fully but not used for a long time (about 1 year), it becomes discharged. Charge it again, but in this case the battery life will be shorter than normal. After several charging and discharging cycles, the battery life will recover its original capacity.

Note on the Terminals

If the terminals (metal parts on the back) are not clean, the battery duration will be shortened. When the terminals are not clean or when the battery pack has not been used for a long time, repeat installing and removing the battery pack. This improves the contact condition. Also, wipe the + and - terminals with a soft cloth or paper.

Be Sure to Observe the Following

- To prevent an accident caused by a short circuit, do not allow metal objects such as a necklace to touch the battery terminals. Carry the battery pack attaching to the terminal cover. [d]
- Keep the battery pack away from fire.
- Keep the battery pack dry.
- Do not open nor convert the battery pack.
- Do not expose the battery pack to any mechanical shock.

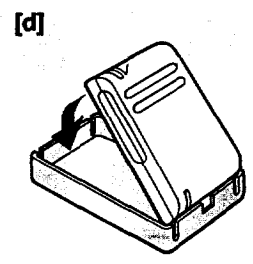
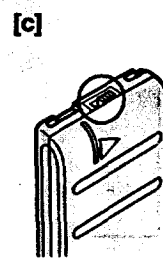
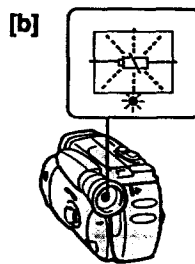
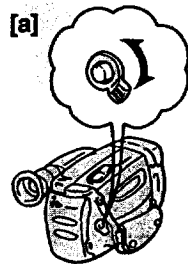

Inserting a Cassette

Make sure that the power source is installed.

(1) While pressing the small blue button on the EJECT knob, slide it down. The cassette holder automatically lifts up and opens. **(2)** Insert a cassette with the window facing out. **(3)** Close the cassette holder by pressing the "PUSH" mark on the cassette holder.

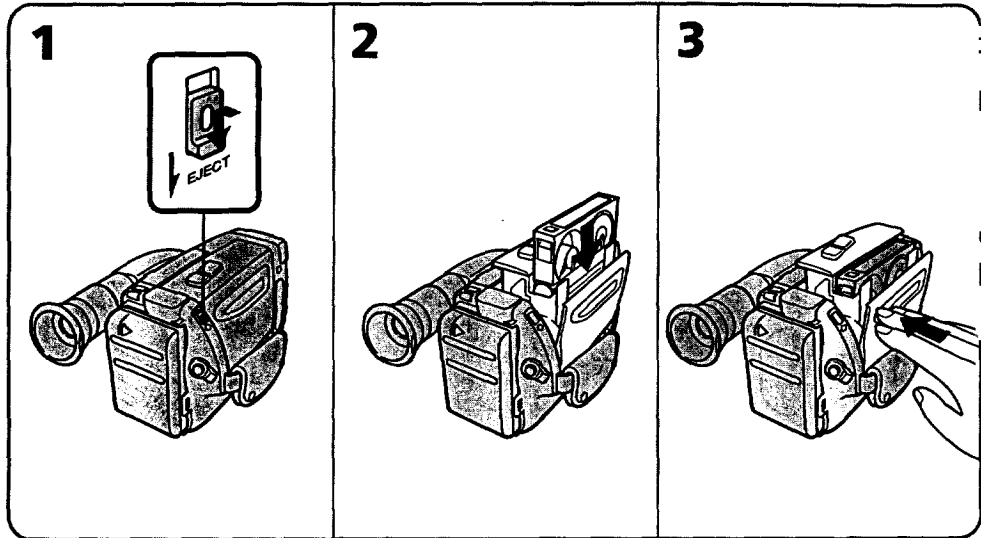

To Eject the Cassette

While pressing the small blue button on the EJECT knob, slide it down.

Adjusting the Viewfinder Lens

Before you use the camcorder for the first time or after someone else has used it, focus the viewfinder lens. Make sure that the power source is attached to the camcorder.

(1) Pull out the viewfinder until it clicks. (2) While pressing the green button of the POWER switch, turn it to CAMERA. (3) Turn STANDBY up. (4) Turn the viewfinder lens adjustment ring so that the indicators in the viewfinder come into sharp focus.

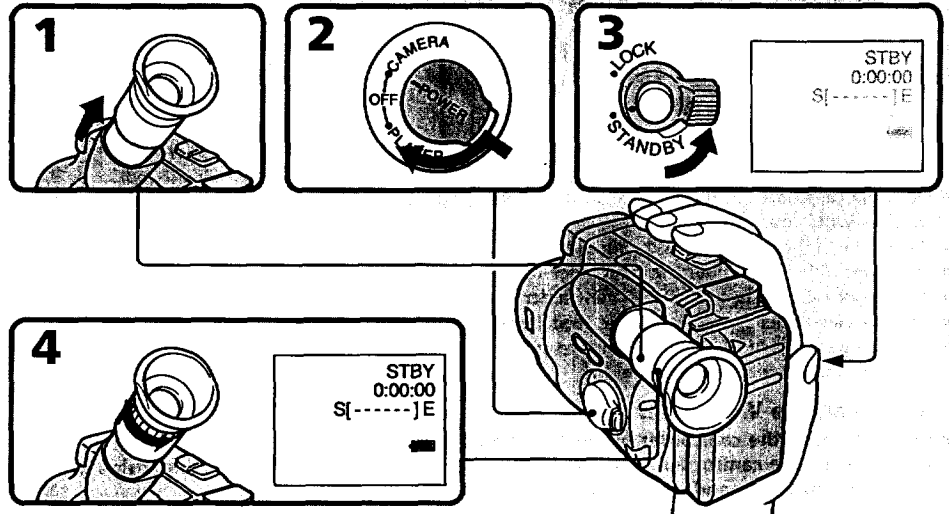

Hints for Better Shooting

For hand-held shots, you'll get better results by holding the camcorder according to the following suggestions:

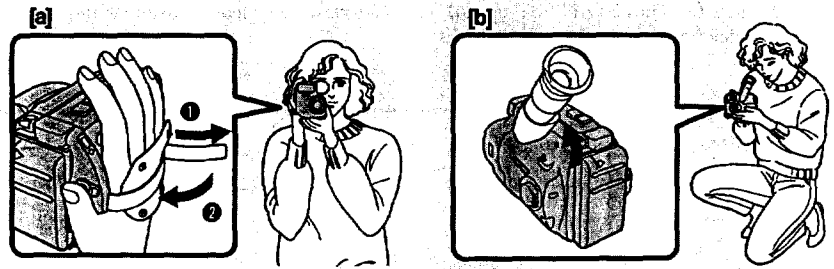

- Hold the camcorder firmly and secure it with the grip strap so that you can easily manipulate the controls with your thumb. [a]
- Place your right elbow against your side.
- Place your left hand under the camcorder to support it.
- Place your eye firmly against the viewfinder eyecup.
- Use the viewfinder frame as a guide to determine the horizontal plane.
- You can also record in a low position to get an interesting recording angle. Turn the viewfinder up for recording from a low position. [b]

Cautions on the Viewfinder

- Do not pick up the camcorder by the viewfinder. [c]
- Do not place the camcorder so as to point the viewfinder toward the sun. The inside of the viewfinder heats up and may be damaged. [d]

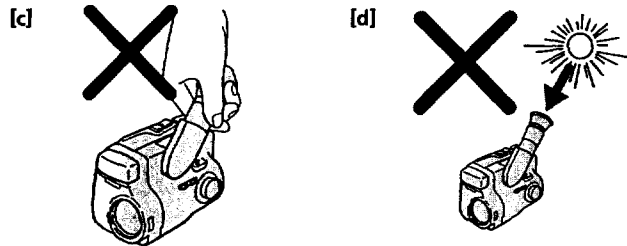

Place the camcorder on a flat surface or use a tripod

Try placing the camcorder on a table top or any other flat surface of suitable height. If you have a tripod for a still camera, you can also use it with the camcorder (p. 33). Make sure the tripod screw is shorter than 9/32 in (6.5 mm).

Basic Operations

Camera Recording

Make sure that the power source is installed and a cassette is inserted. When you start recording, the date is automatically recorded for 10 seconds (AUTO DATE feature). This feature works only once a day. You can use the Remote Commander to record yourself with your friends or family. When you use the Remote Commander, make sure that the REMOTE COMMANDER switch on the camcorder is set to ON (p. 37).

Before you record one-time events, you may want to make a trial recording to make sure that the camcorder is working perfectly.

(1) Pull out the viewfinder until it clicks. (2) Slide the LENS COVER switch to OPEN. (3) While pressing the green button of the POWER switch, turn it to CAMERA. (4) Turn STANDBY up. Adjust the viewfinder lens so that the indicators in the viewfinder come into sharp focus (p. 13). (5) Press START/STOP. As the camcorder starts recording, the red lamp in the viewfinder and the camera recording/battery lamp on the camcorder light up.

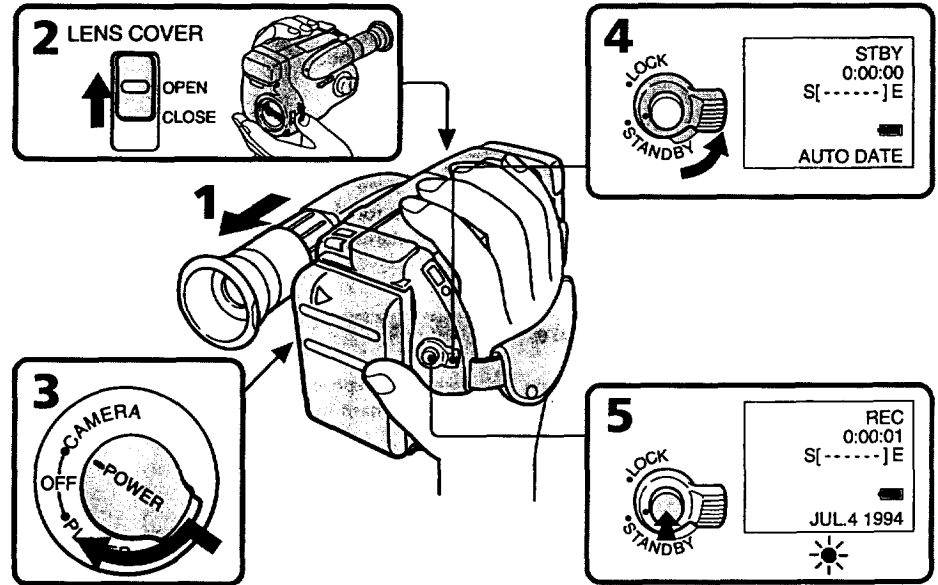

To Stop Recording Momentarily

Press START/STOP again. The "STBY" indicator appears in the viewfinder (Standby mode).

To Finish Recording

Turn STANDBY down and turn the POWER switch to OFF. Slide the LENS COVER switch to CLOSE and eject the tape (p. 12).

Notes on Standby mode

If you leave the camcorder in Standby mode for 5 minutes, the camcorder goes off automatically. This prevents wearing down the battery and wearing out the tape. To resume Standby mode, turn STANDBY down once and turn it up again. To start recording, press START/STOP.

Camera Recording

Note on the tape counter

The tape counter indicates the recording or playback time. Use it as a guide. There will be a time lag of several seconds from the actual time. To set the counter to zero, press COUNTER RESET.

Note on the AUTO DATE feature

- The AUTO DATE feature works once a day. However, the date may automatically appear more than once a day when:
 - you reset the date and time.
 - you eject and insert the tape again.
 - you stop recording within 10 seconds.
- Once the AUTO DATE feature turns off the date display 10 seconds after the start of recording, the date and time are displayed as follows:
 - If the date display setting has been made, the date is displayed.
 - If the time display setting has been made, the time is displayed.
 - If neither display setting has been made, nothing is displayed.

If you wear glasses

You can bend back the eyecup to get a better view of the viewfinder.



When moving from indoors to outdoors (or vice versa)

Turn STANDBY up and point the camcorder at a white object for about 15 seconds so that the white balance is properly adjusted.

Note on recording

When you record from the beginning of a tape, run the tape for about 15 seconds before starting the actual recording. This will ensure that you won't miss any start-up scenes when you playback the tape. You can record tapes in SP (standard play) mode only.

Preventing Accidental Erasure

To prevent accidental erasure, slide the tab on the cassette to expose the red mark. If you try to record with the red mark exposed, the  and  indicators flash in the viewfinder, and you cannot record.

To re-record on this tape, slide the tab back out covering the red mark.

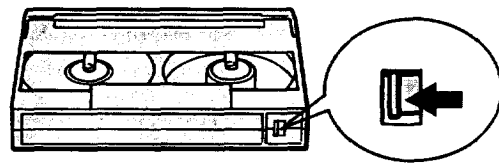

Using the Zoom Feature

Zooming is a recording technique that lets you change the size of the subject in the scene. You can also use the zoom to decide on a shooting angle before you start recording.

For more professional-looking recordings, use the zoom function sparingly.

"T" side: for telephoto (subject appears closer)

"W" side: for wide-angle (subject appears farther away)

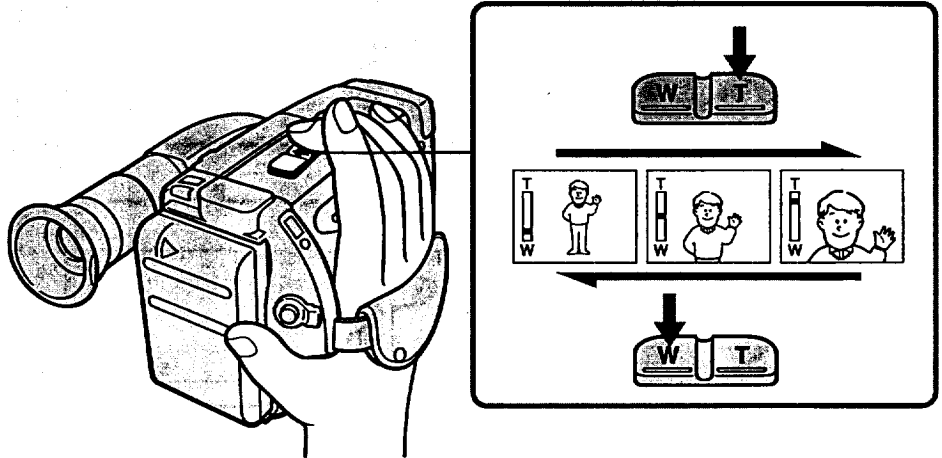

Zooming Speed (Dual speed zooming)

Press the power zoom button firmly for a high-speed zoom, press it softly for a relatively slow zoom.

When you shoot a subject using a telephoto zoom

If you cannot get a sharp focus while in extreme telephoto zoom, press the "W" side of the power zoom button until the focus is sharp. You can shoot a subject that is at least about 31 1/2 inches (80 cm) away from the lens surface in the telephoto position, or about 1/2 inches (1 cm) in the wide-angle position.

Camera Recording

Recording the Date or Time

While you are recording, press DATE (+) or TIME (NEXT). The date or time displayed in the viewfinder is recorded with the picture. You cannot record the date and time at the same time. Except for the date or time indicator, no indicator in the viewfinder is recorded.

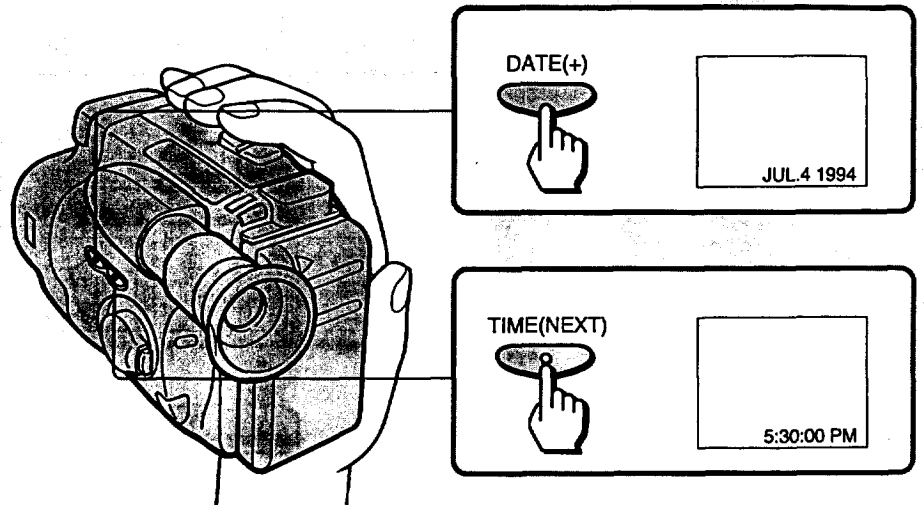

To Stop Recording with the Date and Time

Press DATE (+) or TIME (NEXT) again. The date or time indicator disappears. The recording continues.

Connections for Playback

You can use this camcorder as a VCR by connecting it directly to your TV for playback. There are several ways to connect the camcorder to your TV.

Connecting to a TV without Audio/Video Input Jacks

Connect the camcorder to the TV using the supplied RFU adaptor. Make sure that the TV is turned off to prevent speaker damage before hooking up your camcorder. Set the channel selector on the RFU adaptor and your TV to VHF CH3 or CH4, whichever is not active in your area.

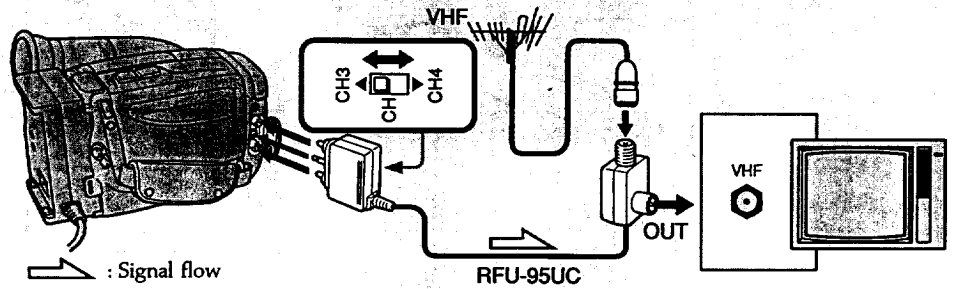

Connecting to a TV or VCR with Audio/Video Input Jacks

Connect the camcorder to the TV using an A/V connecting cable (not supplied). Set the TV/VCR selector on the TV to VCR.

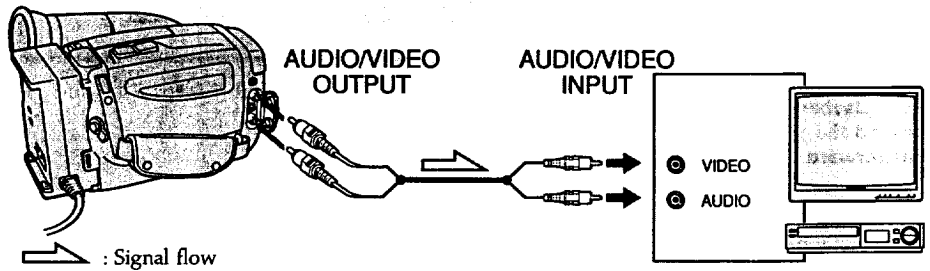

Playing Back a Tape

You can monitor the playback picture in the viewfinder. You can also monitor the picture on a TV screen, after connecting the camcorder to a TV or VCR (p. 19). You can use the supplied Remote Commander to control playback, if you want. Before using the Remote Commander, make sure that the REMOTE COMMANDER switch on the camcorder is set to ON (p. 37).

(1) While pressing the green button of the POWER switch, turn it to PLAYER. (2) Insert the recorded tape with the window facing out. (3) Open the lid of the control panel. (4) Press ▷. Playback starts.

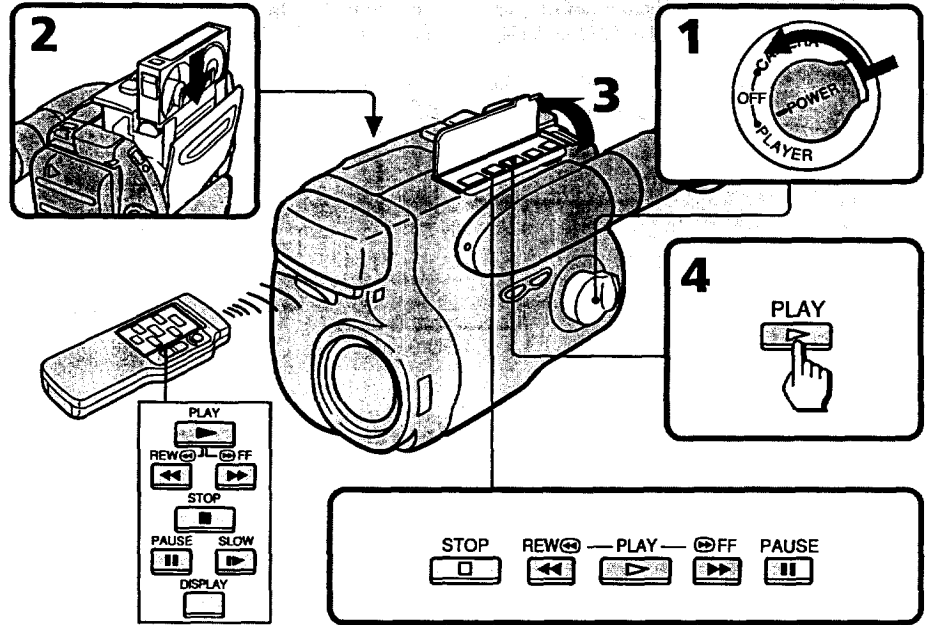

To stop playback, press □.

To rewind the tape, press ◀◀.

To fastforward the tape, press ▶▶.

Various Playback Modes

To view a still picture

Press || during playback. To resume playback, press || or ▷.

To locate a scene (Picture search)

Keep pressing ◀◀ or ▶▶ during playback. To resume normal playback, release the button.

To monitor the high-speed picture during fastforward or rewind (Skip scan)

Keep pressing ◀◀ while rewinding or ▶▶ while advancing the tape. To resume normal playback, press ▷.

To view the picture at 1/5 speed (Slow Playback) (only with the Remote Commander)

Press ■▶ on the Remote Commander during playback. To resume normal playback, press ▶. If slow playback lasts for about 1 minute, it shifts to normal speed automatically.

Note on playback

- Streaks appear and the sound is muted in the various playback modes.
- When still picture mode lasts for 5 minutes, the camcorder automatically enters stop mode.

To display the viewfinder screen indicators on the TV

Press DISPLAY on the Remote Commander. To erase the indicators, press it again.

Advanced Operations

Using Alternate Power Sources

You can choose any of the following power sources for your camcorder: battery pack (p. 6), house current, and 12/24 V car battery. Choose the appropriate power source depending on where you want to use your camcorder.

Place	Power source	Accessory to be used
Indoors	House current	AC-V25/V25A AC power adaptor (supplied), AC-S10, AC-V55
Outdoors	Battery pack	NP-55 Battery pack (supplied), NP-80/80D, NP-77H, NP-66H, NP-60D, NP-55H
In the car	12 V or 24 V car battery	DCP-77 DC pack

Using House Current

To use the supplied AC-V25/V25A AC power adaptor:

(1) Lift up the viewfinder. (2) Connect the AC power cord to a wall outlet. Connect the bottom of the AC power adaptor to the battery mounting surface of the camcorder. (3) Set the selector to VTR (DC OUT).

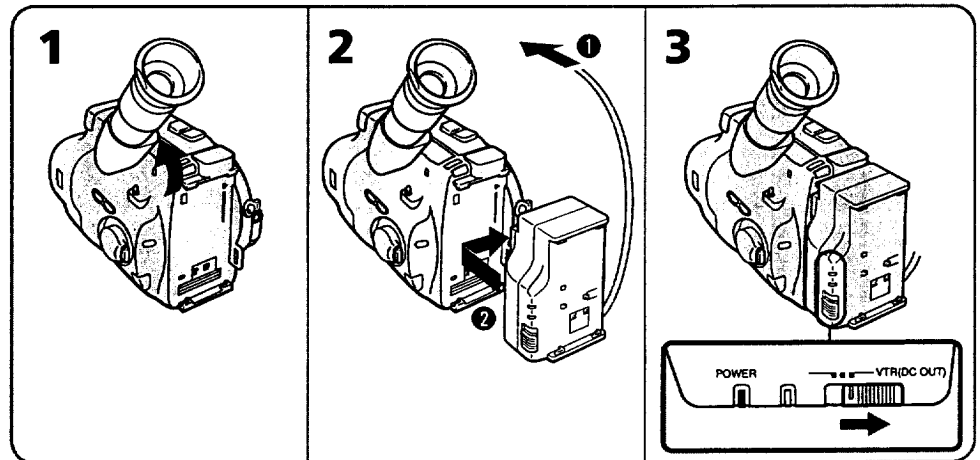

Note on the POWER lamp

- The POWER lamp will remain lit for a while even if the unit is unplugged after use. This is normal.
- If the POWER lamp does not light, set the selector to the center position and disconnect the power cord. After about one minute, reconnect the power cord and set the selector to VTR (DC OUT) again.

To remove the adaptor

The adaptor is removed in the same way as the battery pack. (p. 8)

Using Alternate Power Sources

Using a Car Battery

Use the DCP-77 DC pack (not supplied). Connect the cord of the DC pack to the cigarette lighter socket of the car (12 V or 24 V). Connect the DC pack to the battery mounting surface of the camcorder.

To remove the DC pack

The DC pack is removed in the same way as the battery pack. (p. 8)

Options for Charging the Battery Pack

- AC-S10 AC power adaptor:
You can charge a battery pack whether it is used up or not with this adaptor because it has a discharging function.
- BC-S10 portable battery charger (ideal for travel):
You can charge a battery pack on 100-240 V AC current.

Editing onto Another Tape

You can create your own video program by editing with any other **8** 8 mm, **Hi8** Hi8, **VHS** VHS, **S-VHS** S-VHS, **VHSC** VHSC, **S-VHSC** S-VHSC, **B** Betamax or **Beta** ED Betamax VCR that has audio/video inputs.

Before Editing

Connect the camcorder to the VCR using an A/V connecting cable (not supplied). (p. 19)
Set the input selector on the VCR to LINE, if available. Set the POWER switch to PLAYER.

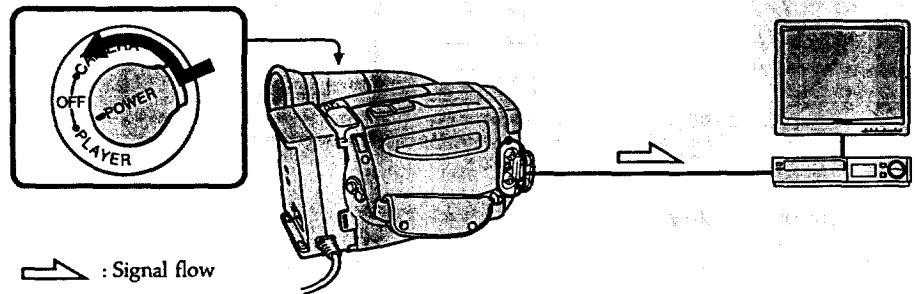

Starting Editing

(1) Insert a blank tape (or a tape you want to record over) into the VCR. And insert your recorded tape into the camcorder. (2) Play back the tape on the camcorder until you locate the point where you want to start editing, then set the camcorder in the playback pause mode. (3) On the VCR, locate the recording start point and set the VCR in that recording pause mode. (4) Press **II** on the camcorder and VCR simultaneously to start editing.

To Edit More Scenes

Repeat steps 2 to 4.

To Stop Editing Momentarily

Press **II** on the VCR.

To Stop Editing

Press **□** on both the camcorder and the VCR.

Note on the DISPLAY function

If you have displayed the viewfinder screen indicators on the TV, erase the indicators by pressing DISPLAY on the Remote Commander so that they will not be superimposed on the edited tape.

Additional Information

Changing the Lithium Battery

Your camcorder is supplied with the lithium battery installed. The lithium battery lasts for about 1 year under normal operation. When the battery becomes weak or dead, the  indicator flashes in the viewfinder for about 5 seconds when you set the POWER switch to CAMERA. In this case, replace the battery with a Sony CR2025 or Duracell DL-2025 lithium battery. Use of another battery may present a risk of fire or explosion.

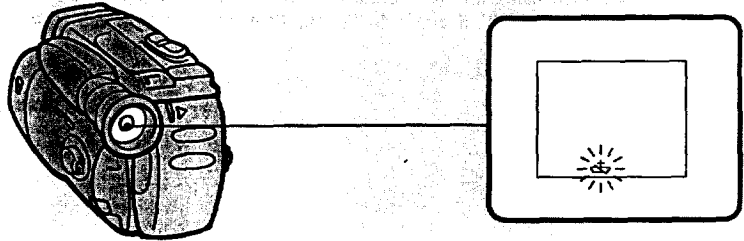

Note on Lithium Battery

The lithium battery has a positive (+) side and a negative (-) side as illustrated below. Be sure to install the lithium battery with the positive side facing out.

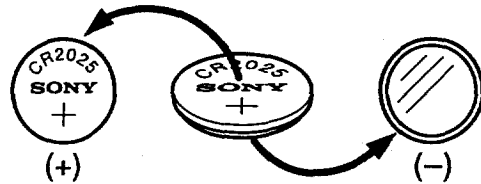

Changing the Lithium Battery

When replacing the lithium battery, keep the battery pack or other power source attached. Otherwise, you will need to reset the date and time.

(1) Detach the lid of the lithium battery compartment on the bottom of the camcorder. (2) Push the battery down once and pull it out from the holder. (3) Install the lithium battery with the positive (+) side facing out. Replace the lid.

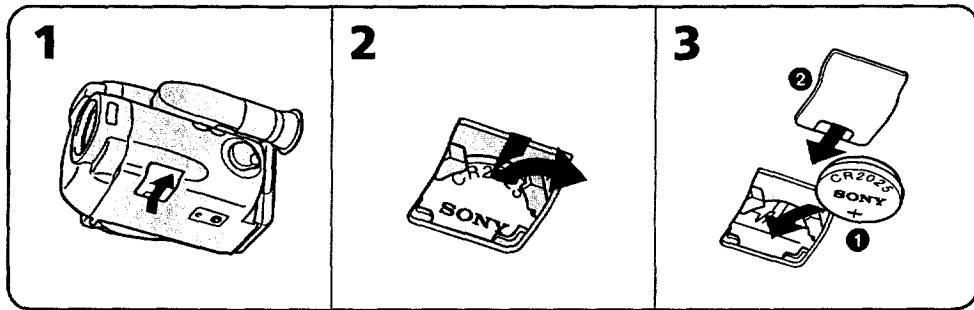

WARNING

The battery may explode if mistreated. Do not recharge, disassemble, or dispose of in fire.

Caution

Keep the lithium battery out of the reach of children.
Should the battery be swallowed, consult a doctor immediately.

Resetting the Date and Time

Your camcorder's clock is set to East Standard Time at the factory, but you can reset the date and time. Set the POWER switch to CAMERA and turn STANDBY up. Adjust the digits in the viewfinder.

- (1) Press DATE (+) and TIME (NEXT) simultaneously until the date appears in the viewfinder.
- (2) Adjust the digits of the year, month, day, hour and minutes by pressing DATE (+) and TIME (NEXT). To set the year to 1994, there is no need to press DATE (+) in 2-①. Note that when you keep DATE (+) pressed, the digits advance faster.

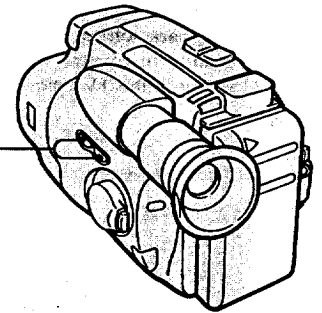
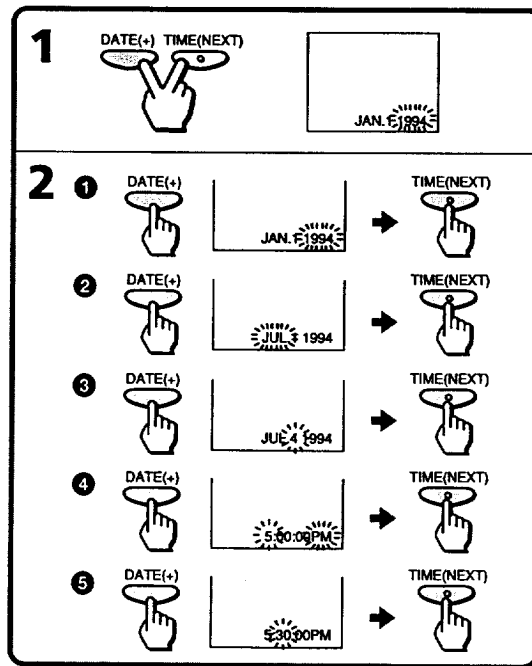

Resetting the Date and Time

To Correct the Date and Time Settings

Press TIME (NEXT) repeatedly until the minute digits stop flashing. Then repeat steps 1 and 2.

To Check the Preset Date and Time

Press DATE (+) or TIME (NEXT). When you press the same button again, the indicator goes off.

Note on the setting of the year

When you set the year, each time you press DATE (+) the digits change as follows.

1994 → 1995 → --- → 2020
↑
└──────────────────────────┘

Note on the time indicator

The internal clock of this camcorder operates on a 12-hour cycle.

12:00 AM stands for midnight.

12:00 PM stands for noon.

Playback Modes

The playback mode (SP or LP) is selected automatically according to the format in which the tape has been recorded. The quality of the recorded picture in LP mode, however, will not be as good as that in SP mode.

LP (long play) mode

When you playback a tape recorded in LP mode, the LP indicator lights up in the viewfinder.

This camcorder cannot record a tape in LP mode.

Foreign 8 mm video

You cannot playback software recorded on a different TV color system. Because the TV color systems differ from country to country, you may not be able to playback foreign pre-recorded software. Refer to page 31 to check the TV color system of foreign countries.

Maintenance Information and Precautions

Video Head Cleaning

To ensure clear pictures, clean the video heads periodically. When playback pictures are "noisy" or hardly visible, the video heads may be contaminated.



[a] Slight contamination

[b] Critical contamination

If this happens, clean the video heads with the Sony V8-25CLH cleaning cassette (not supplied). After checking the picture, if it is still "noisy", repeat the cleaning. (Do not repeat cleaning more than 5 times.)

Caution

Do not use a commercially available wet-type cleaning cassette. It may damage the video heads.

Note

If the V8-25CLH cleaning cassette is not available in your area, consult your Sony service facility.

Removing Dust from inside the Viewfinder

(1) Pull out the viewfinder barrel until the illustrated mark appears. (2) Turn the viewfinder counterclockwise until it stops, and pull it out. (3) Clean the surface with a commercially available blower.

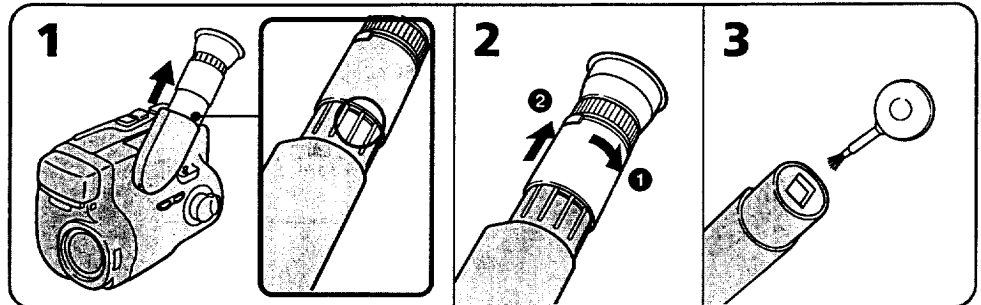

Maintenance Information and Precautions

To Reattach the Viewfinder Barrel

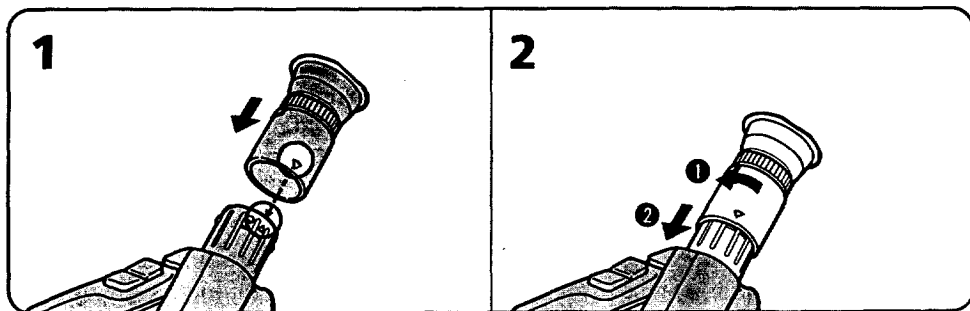

(1) Align the mark on the viewfinder barrel with the mark on the viewfinder and push in the viewfinder barrel until it clicks. (2) Turn it clockwise until it stops and push it in.



Moisture Condensation

If the camcorder is brought directly from a cold place to a warm place, moisture may condense inside the camcorder, on the surface of the tape, or on the lens. In this condition, the tape may stick to the head drum and be damaged or the unit may not operate correctly. To prevent possible damage under these circumstances, the camcorder is furnished with moisture sensors. However, take the following precautions.

Inside the Camcorder

When the  and  indicators flash in the viewfinder, moisture has condensed inside the camcorder. If this happens, no other functions except for tape ejection will work.

Eject the cassette, turn off the camcorder and leave it with the cassette holder open for at least one hour in a dry place.

The camcorder can be used again if the  indicator does not appear when the power is turned on again.

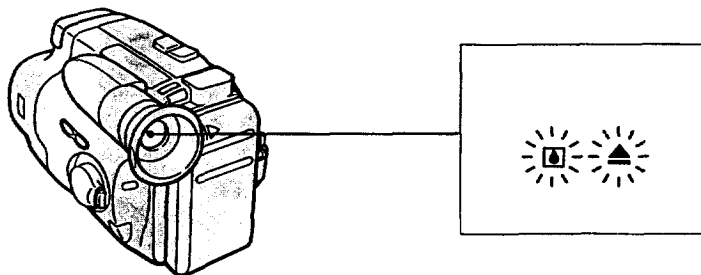

On the Surface of the Tape

If there is moisture on the surface of the tape, when the cassette is inserted and a tape transport button is pressed, the  indicator in the viewfinder flashes. In this case, no other functions except for tape ejection will work.

Eject the cassette, turn off the camcorder and leave it with the cassette holder open for at least one hour in a dry place.

The camcorder can be used again if the  indicator does not appear when you insert the cassette and press one of the tape transport buttons.

On the Lens

If moisture condenses on the lens, no indicator appears, but the picture becomes dim. Turn off the power and do not use the camcorder for about one hour.

How to Prevent Moisture Condensation

When bringing the camcorder from a cold place to a warm place, put the camcorder in a plastic bag and allow it to adapt to room conditions over a period of time.

- (1) Be sure to tightly seal the plastic bag containing the camcorder.
- (2) Remove the bag when the air temperature inside it has reached the temperature surrounding it (after about one hour).

Precautions

Camcorder Operation

- Operate the camcorder on 6.0 V (battery pack) or 7.5 V (AC power adaptor).
- For DC or AC operation, use the accessories recommended in this manual.
- Should any solid object or liquid fall into the casing, unplug the camcorder and have it checked by qualified personnel before operating it any further.
- Avoid rough handling or mechanical shock. Be particularly careful of the lens.
- Keep the LENS COVER switch set to CLOSE when not using the camera.
- Do not wrap up the camcorder and operate it since heat may build up internally.
- Keep the camcorder away from strong magnetic fields or mechanical vibration.
- Do not drop the camcorder.

On Handling Tapes

Do not insert anything in the small holes on the rear of the cassette. These holes are used to sense the type, thickness of tape, or if the tab is out or in, etc.

Camcorder Care

- **When the camcorder is not to be used for a long time, disconnect the power source and remove the tape.** Periodically turn on the power, operate the camera and player sections and play back a tape for about 3 minutes.
- Clean the lens with a soft brush to remove dust. If there are fingerprints on it, remove them with a soft cloth.
- Clean the camcorder body with a dry soft cloth, or a soft cloth lightly moistened with a mild detergent solution. Do not use any type of solvent which may damage the finish.

Maintenance Information and Precautions

AC Power Adaptor

Charging

- Repeated charging while some capacity remains causes a lowering of battery capacity. However, the original battery capacity can be recovered if you use the battery completely and charge it fully again.

- Charge the battery on a flat place without vibration.
- The battery will get hot during charging. But this is normal.

Do not continuously recharge a charged battery pack as that will cause the battery pack efficiency to deteriorate.

Charging temperature

The temperature range for charging is 41°F to 95°F (5°C to 35°C). However, to provide maximum battery efficiency, the recommended temperature range when charging is 50°F to 86°F (10°C to 30°C).

Others

- The model for USA or Canada: One blade of the plug is wider than the other for the purpose of safety and will fit into the power outlet only one way. If you are unable to insert the plug fully into the outlet, contact your dealer.
- Unplug the unit from the wall outlet when not in use for a long time. To disconnect the cord (mains lead), pull it out by the plug. Never pull the cord itself.
- Do not operate the unit with a damaged cord or if it has been dropped or damaged.
- Do not bend the AC power cord forcibly, or put a heavy object on it. This will damage the cord and may cause a fire or an electrical shock.
- Be sure that nothing metallic comes into contact with the metal parts of the connecting plate. If it does, a short may occur and the unit may be damaged.
- Always keep the metal contacts clean.
- Do not disassemble the unit.
- Do not apply mechanical shock or drop the unit.
- While the unit is in use, particularly during charging, keep it away from AM receivers and video equipment because it will disturb AM reception and video operation.
- While the unit is in use, it gets hot. But this is normal.
- Do not place the unit in locations where it is;
 - Extremely hot or cold
 - Dusty or dirty
 - Very humid
 - Vibrating

If any difficulty should arise, unplug the unit and contact your nearest Sony dealer.

Using Your Camcorder Abroad

Each country has its own electricity and TV color system. Before using your camcorder abroad, check the following points.

Power Sources

You can use your camcorder in any country with the supplied AC power adaptor within 110 V to 240 V AC, 50/60 Hz.

Use a commercially available AC plug adaptor [a], if necessary, depending on the design of the wall outlet [b].

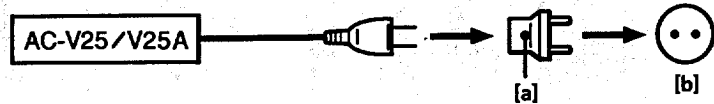

Difference in Color System

This camcorder is an NTSC system based camcorder. If you want to view the playback picture on a TV, it must be an NTSC system based TV or a PAL-M system based TV with an NTSC/PAL-M transcoder.

Check the following list.

NTSC system countries

Bahama Islands, Bolivia, Canada, Central America, Chile, Colombia, Ecuador, Jamaica, Japan, Korea, Mexico, Peru, Surinam, Taiwan, the Philippines, the U.S.A., Venezuela, etc.

PAL system countries

Australia, Austria, Belgium, China, Denmark, Finland, former West Germany, Great Britain, Holland, Hong Kong, Italy, Kuwait, Malaysia, New Zealand, Norway, Portugal, Singapore, Spain, Sweden, Switzerland, Thailand, etc.

PAL-M system country

Brazil

PAL-N system countries

Argentina, Paraguay, Uruguay

SECAM system countries

Bulgaria, France, Guiana, Hungary, Iran, Iraq, Monaco, Poland, former Soviet Union, etc.

Identifying the Parts

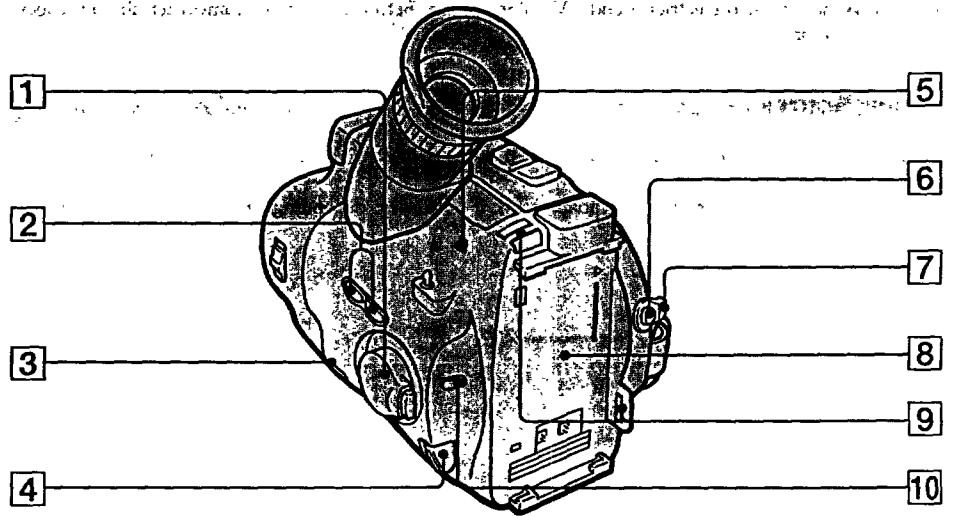

1 POWER switch (p. 15, 20)

2 DATE (+) and TIME (NEXT) buttons (p. 25)

3 Lithium battery compartment
(bottom of the camcorder) (p. 24)

4 BATT (battery eject) knob (p. 8)

5 REMOTE COMMANDER switch (p. 37)

6 START/STOP button (p. 15)

7 STANDBY switch (p. 15)

8 Battery mounting surface (p. 8)

9 Hooks for shoulder strap (p. 38)

10 COUNTER RESET button (p. 16)

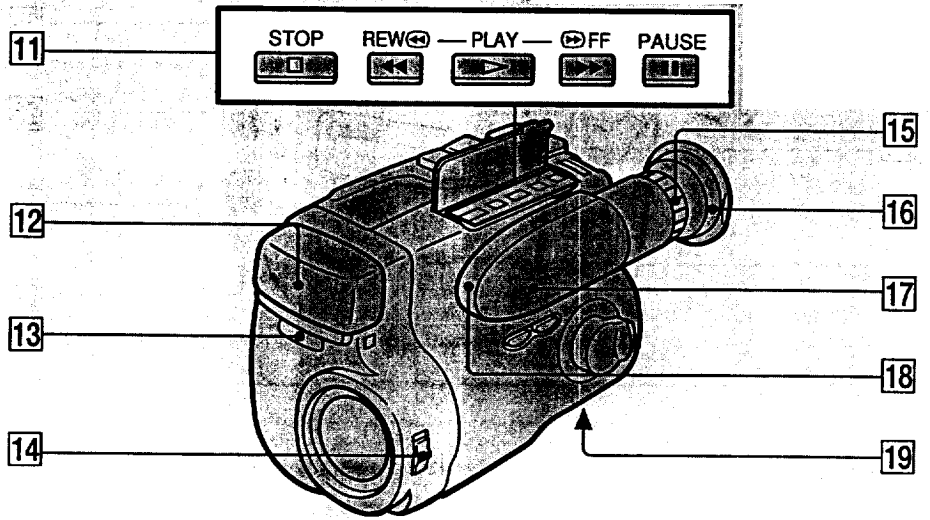

11 **Tape transport buttons** (p. 20)

- STOP
- ◀ REW (rewind)
- ▶ PLAY (playback)
- ▶▶ FF (advancing the tape)
- || PAUSE

12 **Built-in microphone**

13 **Remote sensor** (p. 37)

Aim the Remote Commander here for remote control.

14 **LENS COVER switch**

15 **Viewfinder lens adjustment ring** (p. 13)

16 **Eyecup**

17 **Viewfinder** (p. 13)

18 **Camera recording/battery lamp**

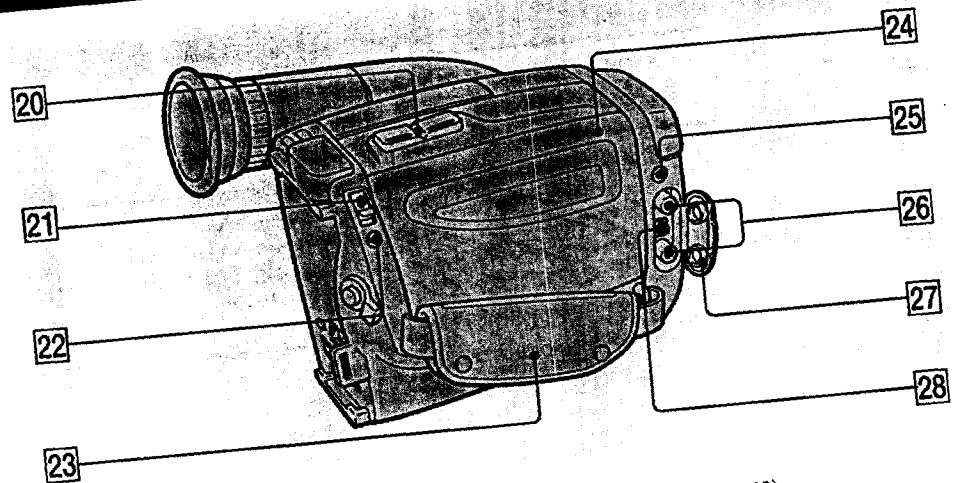

19 **Tripod receptacle** (p. 14)

Identifying the Parts



20 Power zoom button (p. 17)

21 EJECT knob (p. 12)

22 REMOTE  (LANC) control jack
 stands for Local Application Control Bus System. The  control jack is used for controlling the tape transport of video equipment and peripherals connected to it. This jack has the same function as the jack indicated as CONTROL L or REMOTE.

23 Grip strap (p. 14)

24 Cassette holder (p. 12)

25 MIC jack (PLUG IN POWER)
 Connect an optional external microphone (stereo or monaural). This jack also accepts a "plug-in-power" microphone.

26 Audio/Video output jacks (p. 19)

27 Jack cover

28 RFU DC OUT (RFU adaptor DC output) jack (p. 19)

Operation Indicators

For details on each indicator, refer to the pages indicated in the parentheses.

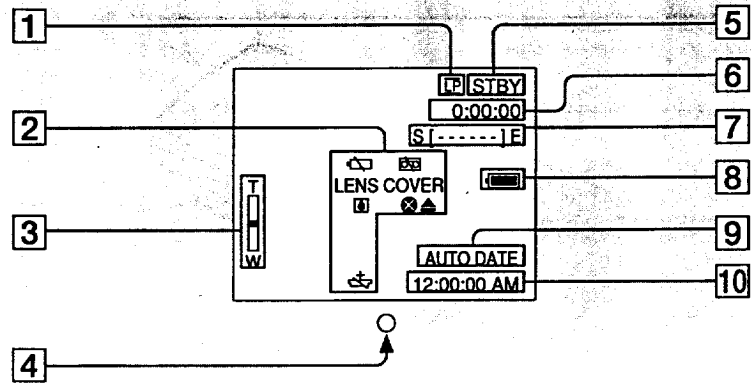

- 1** Lights up when playing back a tape recorded in LP mode.
- 2** Warning indicators (p. 43)
- 3** Power zoom indicator (p. 17)
- 4** Recording lamp/Battery lamp
- 5** Tape transport mode (p. 15)
- 6** Tape counter (p. 16)

- 7** Remaining tape length indicator



- 8** Remaining battery indicator (p. 9)



- 9** AUTO DATE indicator (p. 15)

- 10** Date or Time (p. 25)

Identifying the Parts

Remote Commander

The buttons that have the same name on the Remote Commander and on the camcorder function identically.

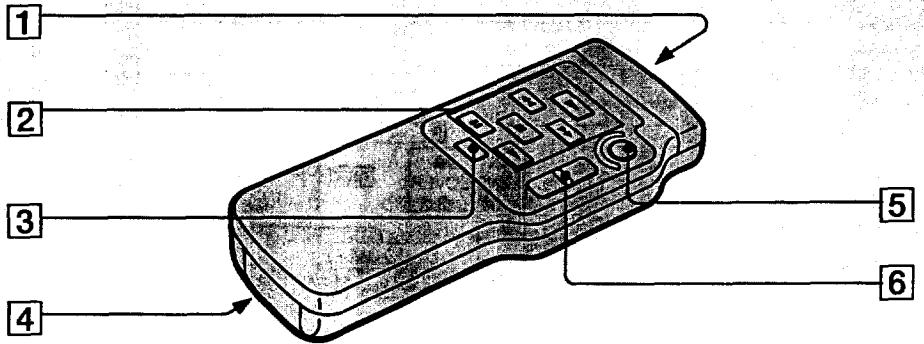

- 1 Transmitter**
Point toward the remote sensor to control the camcorder after turning on the POWER switch on the camcorder.
- 2 Tape transport buttons**
- 3 DISPLAY button**
- 4 Size AA (R6) battery holder**
- 5 START/STOP button**
- 6 Power zoom button**
The zooming speed is unchangeable in the Remote Commander.

Preparing the Remote Commander

To use the Remote Commander, you must insert two size AA (R6) batteries. Use the supplied size AA (R6) batteries.

(1) Remove the battery cover from the Remote Commander. **(2)** Insert both of the size AA (R6) batteries with correct polarity. **(3)** Put the battery cover back onto the Remote Commander.

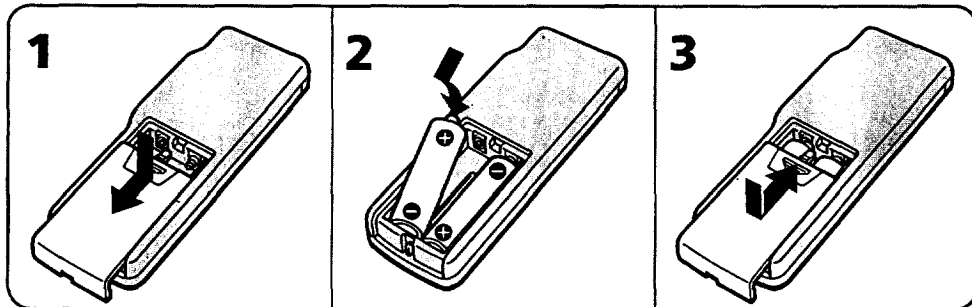

Battery Life

The batteries for the Remote Commander last about 6 months under normal operation. When the batteries become weak or dead, the Remote Commander does not work.

To avoid damage from possible battery leakage

Remove the batteries when you will not use the Remote Commander for a long time.

Using the Remote Commander

Make sure that the REMOTE COMMANDER switch on the camcorder is set to ON.

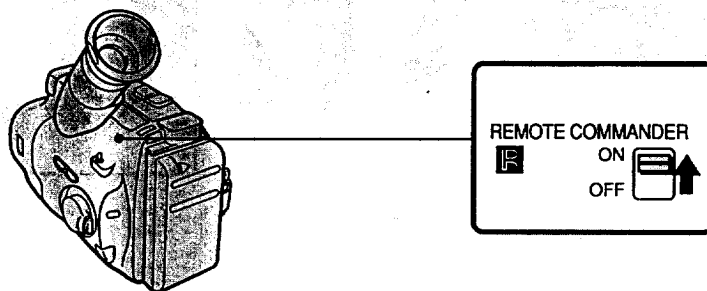

Remote Control Direction

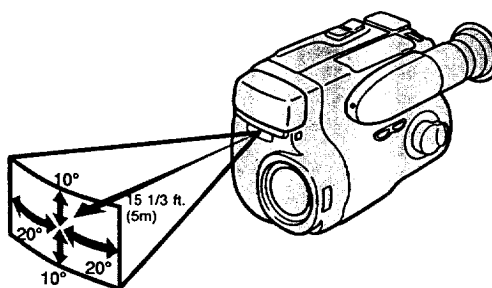

Note on the Remote Commander

- Keep the remote sensor away from strong light sources such as direct sunlight or illumination. Otherwise, the remote control may not be effective.
- Be sure that there is no obstacle between the remote sensor and the Remote Commander.
- This camcorder works at commander mode VTR 2. The commander modes (1, 2 and 3) are used to distinguish this camcorder from other Sony VCRs to avoid remote control misoperation. If you use another Sony VCR at commander mode VTR 2, we recommend you change the commander mode or cover the remote sensor of the VCR with black paper.

Identifying the Parts

Attaching the Shoulder Strap

Attach the supplied shoulder strap to the hooks for the shoulder strap (p. 32).

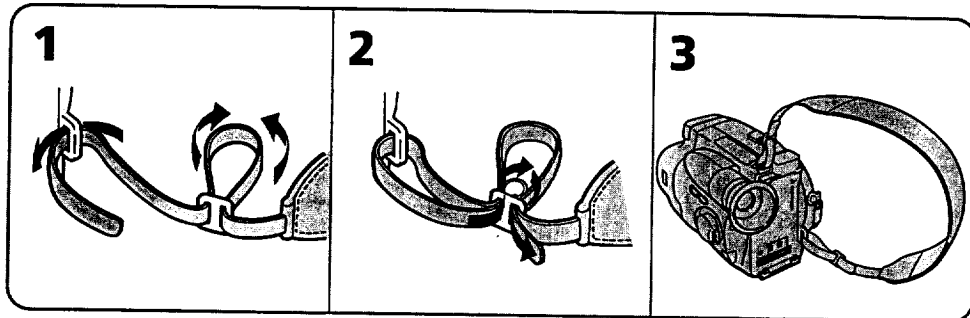

Specifications

Video Camera Recorder

System

Video recording system	Two rotary heads, Helical scanning FM system
Audio recording system	Two rotary heads, FM system
Video signal	NTSC color, EIA standards
Usable cassette	8 mm video format cassette (standard 8 mm)
Tape speed	SP mode: Approx. 19/32 inches (1.43 cm)/s LP mode: Approx. 5/16 inches (0.72 cm)/s (playback only)
Recording time	SP mode: 2 hours (P6-120)
Playback time	SP mode: 2 hours (P6-120) LP mode: 4 hours (P6-120)
Fastforward/rewind time	Approx. 6 min 30 s (P6-120)
Image device	CCD (Charge Coupled Device)
Viewfinder	Electronic viewfinder (monochrome)
Lens	Combined 10 x Power zoom lens $f = 1/4$ to $2\ 7/16$ inches (6.2 to 62 mm) F 1.6 to 2.9 (45 to 450 mm when converted to a 35 mm still camera) Filter diameter 1 1/2 inches (37 mm) TTL autofocus system inner focus wide macro system
Color temperature	Auto
Minimum illumination	2 lx (F 1.6)
Illumination range	2 lx to 100,000 lx
Recommended illumination	More than 100 lx

Input and output connectors

Video output	Phono jack, 1 Vp-p, 75 Ω , unbalanced, sync negative
Audio output	Phono jacks -7.5 dBs, (at load impedance 47 k Ω) impedance less than 2.2 k Ω
RFU DC OUT	Special minijack, DC 5 V
Remote jack	Stereo mini-minijack (\varnothing 2.5 mm)
MIC jack	Minijack, -66 dBs low impedance with 2.5 to 3 V DC, output impedance 6.8 k Ω (\varnothing 3.5 mm)

Design and specifications are subject to change without notice.

General

Power requirements	On battery mounting surface 6.0 V (battery pack) 7.5 V (AC power adaptor)
Average power consumption	5.3 W (camera recording) including the viewfinder
Installation	Vertically, horizontally
Operating temperature	32 °F to 104 °F (0 °C to 40 °C)
Storage temperature	-4 °F to +140 °F (-20 °C to +60 °C)
Dimensions	Approx. 4 3/8 x 4 3/8 x 7 1/8 inches (w/h/d) (109 x 109 x 178 mm)
Mass	Approx. 1 lb 10 oz (750 g) excluding the battery pack, lithium battery, cassette and shoulder strap Approx. 2 lb 2 oz (970 g) including the battery pack NP-55, lithium battery CR2025, cassette P6-120 and shoulder strap
Microphone	Electric condenser microphone, monaural type
Supplied accessories	See page 5.

AC power adaptor

Power requirements	110-240 V AC*, 50/60 Hz
Power consumption	15 W (AC-V25) / 17 W (AC-V25A)
Output voltage	DC OUT: 7.5 V, 1.2 A (AC-V25) 7.5 V, 1.5 A (AC-V25A) in operating mode
	Battery charge terminal: 10 V, 1.1 A in charge mode
Application	Sony battery packs NP-55/55H, NP-60D, NP-66H, NP-77H, NP-80/80D
Operating temperature	32 °F to 104 °F (0 °C to 40 °C)
Storage temperature	-4 °F to +140 °F (-20 °C to +60 °C)
Dimensions	Approx. 4 1/8 x 1 15/16 x 2 1/2 inches (w/h/d) (103 x 49 x 63 mm) including projecting parts and controls
Mass	Approx. 10 oz (290 g) (AC-V25) Approx. 11 oz (320 g) (AC-V25A)

* Canadian Standard Association (CSA) certifies 120 V AC only.

Trouble Check

If you run into any problem using the camcorder, use the following table to troubleshoot the problem. Should the difficulty persist, disconnect the power source and contact your Sony dealer or local authorized Sony service facility.

Camcorder

	Symptom	Cause	Corrective Actions	page
Power	The power is not on.	The battery is not attached.	Attach the battery.	8
		The battery is dead.	Use a charged battery.	6
		The AC power adaptor is not connected to a wall outlet.	Connect the AC power adaptor to a wall outlet.	21
	The power goes off.	While being operated in CAMERA mode, the camcorder has been in the Standby mode for more than 5 minutes.	Turn STANDBY down once and turn it up again.	15
		The battery is dead.	Use a charged battery.	6
	The battery pack is quickly discharged.	The ambient temperature is too low.	—	9
		The battery pack has not been charged fully.	Charge the battery pack again.	6
		The battery pack is completely dead, and cannot be recharged.	Use another battery pack.	10
	Operation	START/STOP does not operate.	The tape is stuck to the drum.	Eject the tape.
The tape has run out.			Rewind the tape or use a new one.	20
The POWER switch is set to PLAYER.			Set it to CAMERA.	15
The tab on the cassette is out (red).			Use a new tape or slide the tab.	16
The cassette cannot be removed from the holder.		The battery is dead.	Use a charged battery or the AC power adaptor.	6 21
No function except for cassette ejection works.		Moisture condensation has occurred.	Remove the cassette and leave the camcorder for at least an hour.	28
The tape does not move when a tape transport button is pressed.		The POWER switch is set to CAMERA or OFF.	Set it to PLAYER.	20
		The tape has run out.	Rewind the tape or use a new one.	20

	Symptom	Cause	Corrective Actions	page
Picture	The image on the viewfinder screen is not clear.	The viewfinder lens is not adjusted.	Adjust the viewfinder lens.	13
	A vertical band appears when a subject such as lights or a candle flame is shot against a dark background.	The contrast between the subject and background is too high.	The camcorder is not malfunctioning. Change locations.	—
	The playback picture is not clear.	The channel or input for the camcorder is not selected on the TV.	Make the correct selection.	19
	The picture is "noisy".	The video heads may be dirty.	Clean the heads using the Sony V8-25CLH cleaning cassette.	27
Others	The supplied Remote Commander does not work.	The REMOTE COMMANDER switch is set to OFF.	Set it to ON.	37
		Something interrupts the infrared rays.	Remove the obstacles.	—
		The battery is not inserted with the correct polarity.	Insert the battery with the correct polarity.	36
		The battery is dead.	Insert a new one.	36
	There is dust in the viewfinder.	—	Pull out the viewfinder and clean the viewfinder screen or viewfinder lens.	27

Trouble Check

AC Power Adaptor

	Symptom	Cause	Corrective Actions	page
AC power adaptor	The POWER lamp does not light.	—	Set the selector to the center position and disconnect the power cord. After about one minute, reconnect the power cord and set the selector to CHARGE again.	8
	The CHARGE lamp flashes.	See the following chart.		

When the CHARGE Lamp Flashes

Check through the following chart.

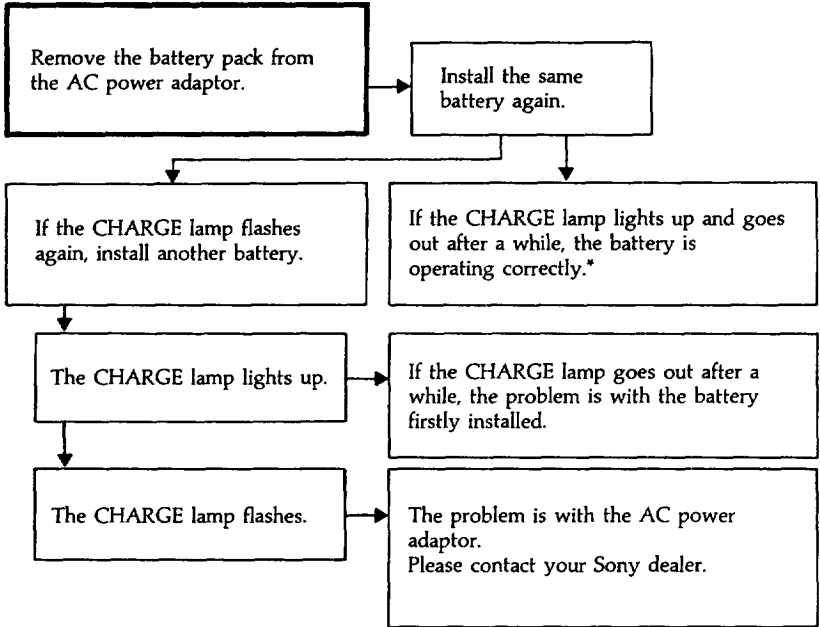

* If you use a battery pack which you have just bought or which has been left unused for a long time, the CHARGE lamp may flash at the first charging. But this is not a problem. Repeat again to charge with the same battery pack.

Indicators in the Viewfinder

Warning Indicators

If indicators flash in the viewfinder or a caution lamp on the camcorder flashes, check the following:

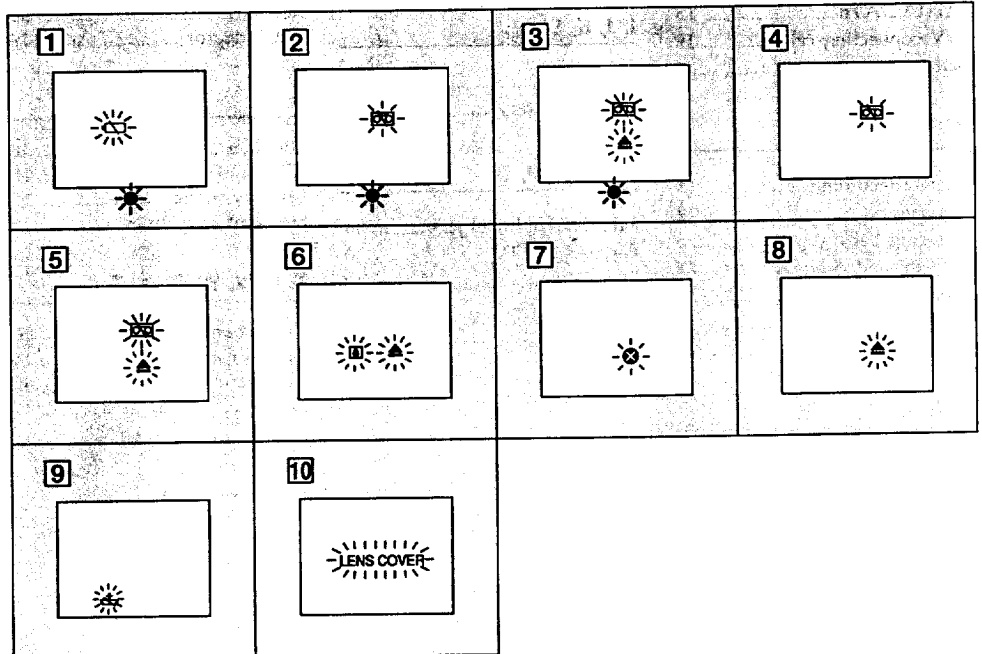

- | | |
|---|---|
| <p>1 The battery is weak or dead.
Slow flashing: The battery is weak.
Fast flashing: The battery is dead.</p> <p>2 The tape is near the end.
The flashing is slow.</p> <p>3 The tape has run out.
The flashing becomes rapid.</p> <p>4 No tape has been inserted.</p> <p>5 The tab on the tape is out (red).</p> | <p>6 Moisture condensation has occurred. (p. 28)</p> <p>7 The video heads may be contaminated.
(p. 27)</p> <p>8 Some other trouble has occurred.
Disconnect the power source and contact
your Sony dealer or local authorized facility.</p> <p>9 The lithium battery is weak or is not
installed. (p. 24)</p> <p>10 The LENS COVER switch is set to CLOSE.</p> |
|---|---|

Index

A, B

AC power adaptor	6, 21
Adjusting viewfinder	13
AUTO DATE	15
A/V connecting cable	19
Battery pack	6

C

Camera recording	15
Car battery	22
Charging battery	6
Cleaning video heads	27
Clock reset	25
Connection	19
COUNTER RESET	16

D, E

DATE/TIME	25
DISPLAY	20
Editing	23
EJECT	12
Eyecup	14

F, G, H

Fastforward	20
-------------------	----

I, J, K, L

LANC	34
Lithium battery	24

M, N, O, P, Q

MIC (microphone) jack	34
Playback on TV	20
PLAYER	20
Power sources	21
Power zoom	17

R

Remote Commander	36
REMOTE control jack	34
Rewind	20
RFU adaptor	19

S

Shoulder strap	38
STANDBY	15
Standby mode	15
Supplied accessories	5

T, U, V, W, X, Y, Z

Tape counter	16
Tripod mounting	14
Trouble check	40
Zoom	17

For Product information or operation, call:
SONY CUSTOMER INFORMATION CENTER
201-368-9272
or write to:
Sony Customer Information Center
One Sony Drive
Park Ridge, New Jersey 07656-8003
