

VIDEO CASSETTE RECORDER OWNER'S MANUAL

MODEL VRT344

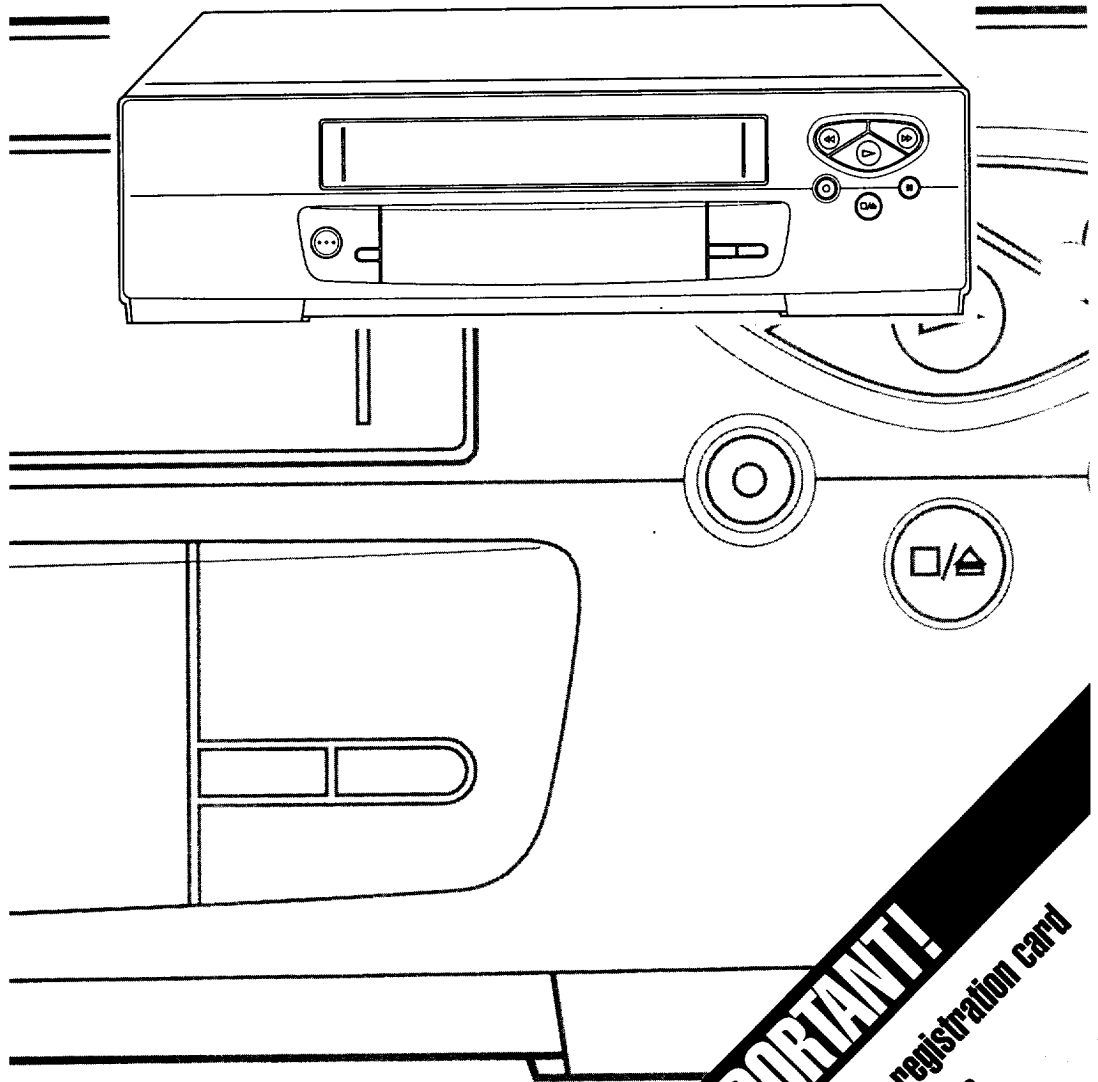

IMPORTANT!
Return your warranty registration card
within 10 days.
See inside cover for details.

MAGNAVOX

Smart.Very smart.®

WARRANTY REGISTRATION CARD

Return your Warranty Registration Card today to ensure you receive all the benefits you're entitled.

Once your MAGNAVOX purchase is registered, you're eligible to receive all the privileges of owning a MAGNAVOX product. So complete and return the Warranty Registration Card enclosed with your purchase at once. And take advantage of these important benefits:

Warranty Verification

Registering your product within 10 days confirms your right to maximum protection under the terms and conditions of your MAGNAVOX warranty.

Owner Confirmation

Your completed Warranty Registration Card serves as verification of ownership in the event of product theft or loss.

Model Registration

Returning your Warranty Registration Card right away guarantees you'll receive all the information and special offers which you qualify for as the owner of your model.

MAGNAVOX

Smart.Very smart.®

Congratulations on your purchase, and welcome to the "family!"

Dear MAGNAVOX product owner:

Thank you for your confidence in MAGNAVOX. You've selected one of the best-built, best-backed products available today. And we'll do everything in our power to keep you happy with your purchase for many years to come.

As a member of the MAGNAVOX "family," you're entitled to protection by one of the most comprehensive warranties and outstanding service networks in the industry.

What's more, your purchase guarantees you'll receive all the information and special offers for which you qualify, plus easy access to accessories from our convenient home shopping network.

And most importantly you can count on our uncompromising commitment to your total satisfaction.

All of this is our way of saying welcome—and thanks for investing in a MAGNAVOX product.

Sincerely,

Robert Minkhorst
President and Chief Executive Officer

P.S. Remember, to get the most from your MAGNAVOX product, you must return your Warranty Registration Card within 10 days. So please mail it to us right now!

HURRY!
Registration
Needed
Within 10
Days.

KNOW THESE SAFETY SYMBOLS



▲ This "bolt of lightning" indicates uninsulated material within your unit may cause an electrical shock. For the safety of everyone in your household, please to not remove product covering.

▲ The exclamation point calls attention to features for which you should read the enclosed literature closely to prevent operating and maintenance problems.

WARNING: TO PREVENT FIRE OR SHOCK HAZARD, DO NOT EXPOSE THIS EQUIPMENT TO RAIN OR MOISTURE

CAUTION: To prevent electrical shock, match wide blade of plug to wide slot and fully insert.

ATTENTION: Pour éviter les chocs électriques, insérez la prise la plus large de la fiche dans la prise correspondante de la prise et poussez fermement.

For Customer Use
Even below the Seal No. will be placed on the seal in the bottom. Having this information will ensure the card.
Model No. _____
Serial No. _____

Introduction

Features

- HQ (High Quality) System
- Frequency Synthesizer Tuning with Auto Set Feature
- On-Screen Displays in English or Spanish
- Display Panel
- Auto Tracking
- One Touch Recording
- Unattended (Timer) Recording
- Special Effects Playback: Forward and Reverse Searching; Still; Variable Slow; Frame Advance
- Wireless Remote Control with TV and Cable Converter Box Control Possibility
- Repeat Playback
- Auto Operation Features
- Real Time Counter
- Daylight-Saving Time
- VCR Plus+ Function
- Time Search Function
- Jog & Shuttle Control
- Automatic Head Cleaner
- Memory Rewind Off

Safety Precautions

Warning: To prevent fire or shock hazard, do not expose this equipment to rain or moisture.

FCC Warning: Any unauthorized changes or modifications to this equipment voids the user's authority to operate it.

This VCR, equipped with a HQ (high quality) system, is compatible with existing VHS (video home system) equipment.

Philips Consumer Electronics Company recommends that you use only video cassette tapes that have been tested and inspected for use in two, four, six and eight hour VCRs, and which are labeled with the **VHS** mark. The use of tapes that have not been inspected for use in two, four, six and eight hour VCRs may result in poor picture quality and excessive deposits on the video heads, which may not be covered by the warranty if damage occurs.

Note to the CATV System Installer: This reminder is provided to call the CATV system installer's attention to Article 820-40 of the NEC, which provides guidelines for proper grounding – in particular, specifying that ground cable shall be connected to the grounding system of the building, as close as to the point of cable entry as possible.

Copyright 1995 Philips Consumer Electronics Company. All rights reserved.

Welcome to your VCR owner's manual. This manual was designed for you. When looking through it, it will help you to keep several things in mind.

One, this manual is divided into four sections. The *Getting Started* section guides you through the initial setup and simple operations of your VCR. The *Operating Your VCR* section shows you where all of the VCR and remote control controls and explains on-screen displays. The *Doing More* section guides you through the more advanced features of your VCR. Finally, the *Information You May Need* section provides information you may or may not need – other hookups, for example, and trouble checks.

Two, the instructions follow a simple format. Detailed steps explaining operations are on the outside edges of pages. Illustrations accompanied by brief steps explaining operations are on the inside edges of pages. Additional information can be found in boxes labeled NOTES along the lower edges of pages.

Finally, never be afraid to try a feature! **You cannot hurt your VCR by trying any of the features in this manual!**

So read on – and relax.

Before doing anything else, record the VCR's model and serial numbers in the spaces provided on page two. These numbers will help us assist you if you ever call for help.

4

Table of Contents

Getting Started

Introduction	3
Table of Contents	4
Before Using Your VCR	5
Hooking Up Your VCR	6
Turning on Your VCR	7
Playing	8
Recording	9
Setting the Clock	10

Operating Your VCR

On-Screen Displays	11
Remote Control Buttons	12
Display Panel	14
Front Panel	15
Rear Panel	16

Doing More

Recording One Channel/Watching Another	17
One Touch Recording	18
Rerecording (Tape Duplication)	19
Timer Recording	20
Setting Up VCR Plus+	22
Timer Recording With VCR Plus+	25
Channel Memory	26
Language/Daylight-Saving Time Selection	28
Playback Options	29
Playback Features	32
TV Code Setting	33
Cable Converter Box Code Setting	34

Information You May Need

Specifications/Notes	35
Other Hookups	36
Before Requesting Service	40
Glossary	41
Warranty	42
Index	43
Accessories	44

Before Using Your VCR

Putting Batteries in the Remote Control

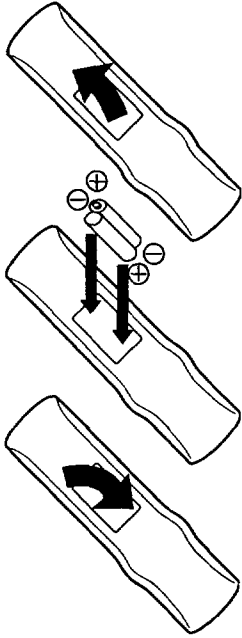

- 1** Remove the battery compartment lid on the bottom of the remote control by sliding it in the direction of the arrow.
- 2** Place two AAA batteries inside the battery compartment with their polarities (+ and - ends) aligned as indicated.
- 3** Replace the battery compartment lid.

- The remote control and its batteries are supplied.
- Do not mix alkaline and manganese batteries.
- Do not mix old and new batteries.

Using the Remote Control

Point the remote control at the VCR's remote sensor, making sure to stay within the angle shown.

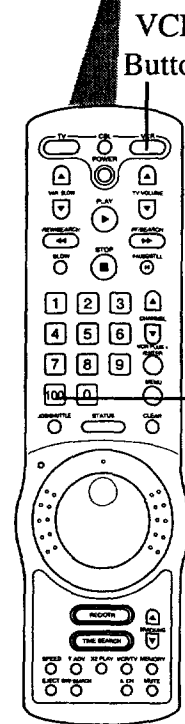
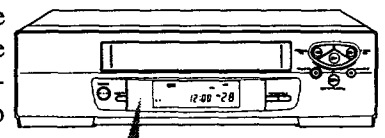

Do not put objects between the remote control and the VCR.

To select channels 1 - 9 using the number buttons, first press 0, then press the desired channel number. For example, for channel 6, press 0, 6.

To select channels 100 - 125 using the number buttons, first press the 100 button, then press the last two digits of the desired channel. For example, for channel 117, press 100, 1, 7.

The 100 button will work only when selecting cable channels and when CABLE TV has been selected at the Tuner Setup menu.

Press the VCR button on the remote control before pressing other VCR operation buttons on the remote control.

Remote Control

Erase Protection

Video cassette tapes have record tabs to ensure that recordings are not accidentally erased.

1 To prevent accidental erasure, break off the tab with a screwdriver.

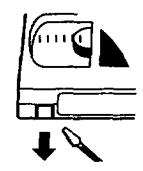

2 To record again, cover the hole with cellophane tape.



Types of Video Cassette Tapes and Tape Speeds

Tape Speed	Maximum Record/Playback Time			
	Type	T160	T120	T60
SP		2 hrs. 40 mins.	2 hrs.	1 hr.
LP		5 hrs. 20 mins.	4 hrs.	2 hrs.
SLP		8 hrs.	6 hrs.	3 hrs.

- In this VCR, use only tapes with the **VHS** mark.
- The chart at the left shows the recording/playback time for three types of video cassettes (T160, T120, T60). There are three playback speeds: SP, LP, and SLP. During playback, the VCR selects the tape speed automatically. When recording, you can change the speed using the (Tape) SPEED button (see page 12).
- Make sure any light adhesive stick-on notes are removed from the video cassette tape before putting it in the VCR. Removable labels like these can jam the VCR.

6

Hooking Up Your VCR

The basic VCR/TV connection – antenna/cable to VCR to TV – is shown below. For other hookups, including those that use cable converter /descrambler boxes, see pages 36 - 39.

1
Disconnect the antenna or cable from your TV.

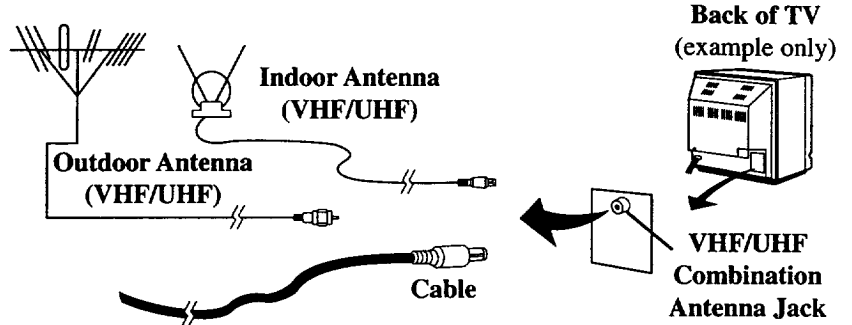

2
Connect the antenna/cable to your VCR.

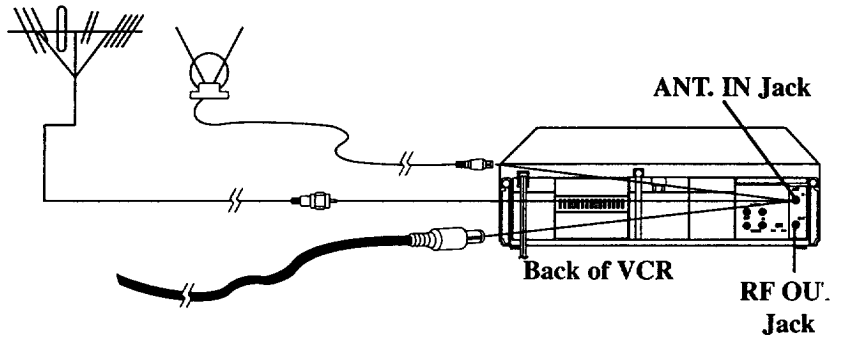

3
Connect your VCR to your TV with the black RF coaxial cable.

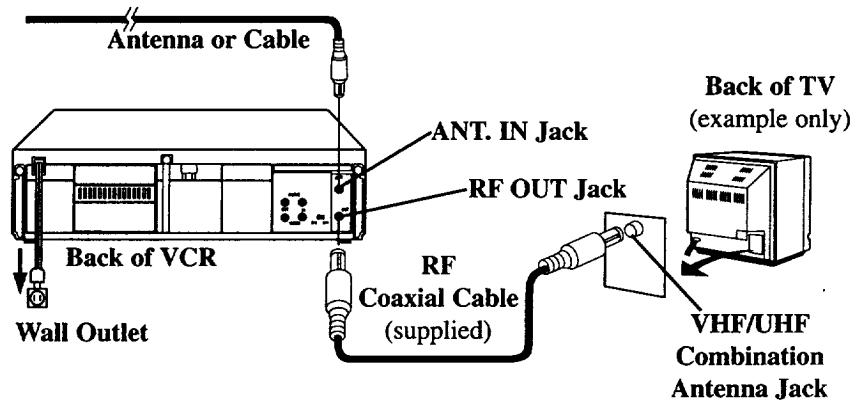

4
Select channel 3 or 4.

Set the CH3/CH4 switch on the back of the VCR to CH3 or CH4, whichever channel is not used or least used in your area. To operate your VCR with your TV, set the TV to the same channel. For example, when playing a tape, if the CH3/CH4 switch is set to CH3, the TV should be on channel 3.

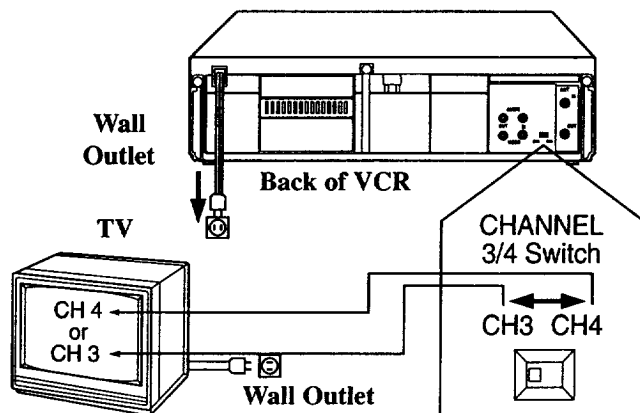

Turning on Your VCR

TV and VCR

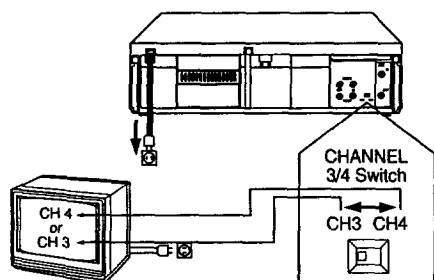

1 Set the TV to channel 3 or 4, whichever channel the CH3/CH4 switch on the back of the TV is set to.

Remote Control

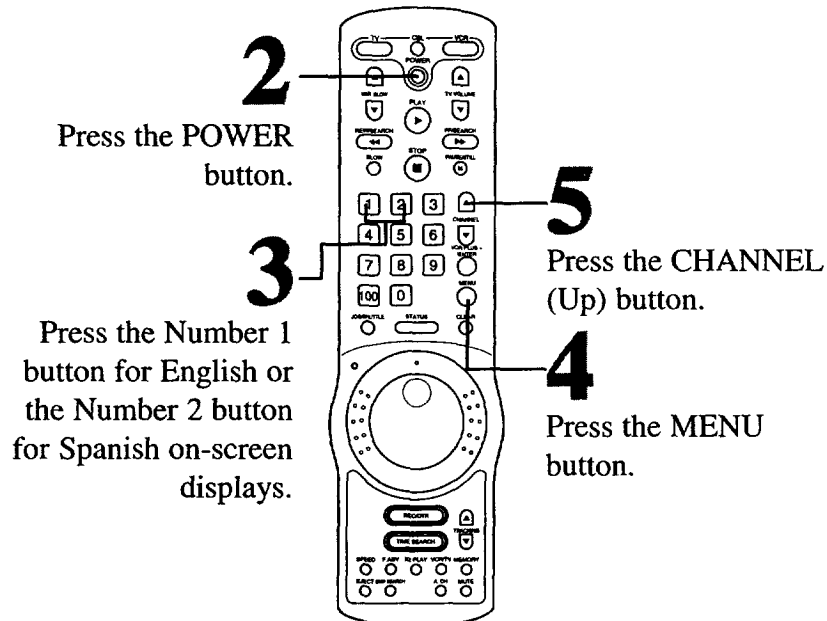

2 Press the POWER button.

3 Press the Number 1 button for English or the Number 2 button for Spanish on-screen displays.

5 Press the CHANNEL (Up) button.

4 Press the MENU button.

Before turning on your VCR, make sure there are batteries in the remote control and the VCR and TV are connected (see pages five and six).

1

Turn the TV on. Set it to the same channel as the CH3/CH4 switch on the back of the VCR.

2

Press the VCR button, then the POWER button. The VCR light will appear and the language select display shown below will appear.

TO SELECT PUSH NO. SHOWN
1 ENGLISH ON
2 ESPAÑOL
MAKE SELECTION OR
PUSH MENU TO CONTINUE

3

Press the Number 1 button to select English on-screen displays or the Number 2 button to select Spanish on-screen displays.

4

Press the MENU button. The channel program display shown below will appear.

CONNECT ANTENNA OR CABLE
TO VCR
THEN...
PUSH CH UP KEY
OR...
FOR PLAY ONLY - PUSH STOP

5

Press the CHANNEL (Up) button to begin automatic channel programming. The VCR will place all of the channels you receive into its memory, so when you scan through channels using the CHANNEL (Up/Down) buttons, you'll only scan through channels that you receive. When channels are programmed, AUTO SET COMPLETED will appear on-screen briefly. Then the TV will go to the lowest channel programmed.

- If you do not see any on-screen displays when you turn on the VCR, repeat the steps under "Hooking Up Your VCR" on page six, then try again. If you still do not see any on-screen displays, follow the steps under "Channel Memory" on page 26 and "Language Selection" on page 28.
- To skip this feature and play a tape immediately, insert a tape with its record tab removed. Playback will start immediately. Or, to skip step 3, press the MENU button. All on-screen displays will be in English. To skip step 4, press the STOP button. Channels will not be programmed, and TUNER NOT SET will appear on-screen.
- To change the language or program channels at a later time, follow the steps on pages 26 and 28.
- If you try to program channels when there is no antenna or cable connected to the VCR, programming will appear to take place, but eventually NO TV SIGNALS will appear on-screen. If this happens, connect an antenna or cable to the VCR and try again.
- You cannot program channels if a cable converter box is connected to a VCR that is connected to a TV. If you have this kind of connection, see page 36 for details.

8

Playing

Read and follow the steps below to play a tape.

1

Turn the TV on and set it to channel 3 or 4, whichever the CH3/CH4 switch on the back of the TV is set to.

2

Insert a tape in the VCR. The power will come on. The VCR will place itself in VCR position automatically (the VCR light and the Cassette-Inside light on the display panel of the VCR will appear). If the tape's record tab has been removed, playback should start automatically.

3

If playback does not start automatically, press the PLAY button to start playback.

4

Press the STOP button on the remote control or the STOP/EJECT button on the VCR to stop playback.

5

Press the REW(ind)/SEARCH button to rewind the tape.

6

Press the EJECT button on the remote control or the STOP/EJECT button on the VCR to remove the tape.

TV and VCR

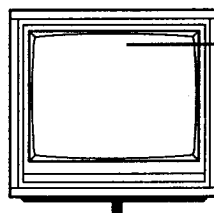

1 Turn the TV on and set it to channel 3 or 4.

2 Insert a tape.

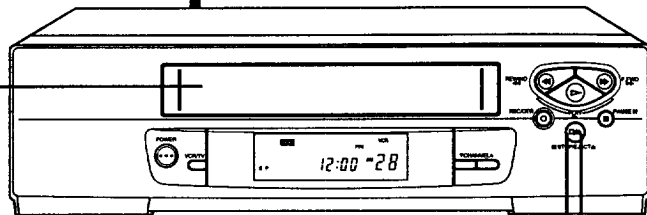

5 Press the REW(ind)/SEARCH button to rewind the tape.

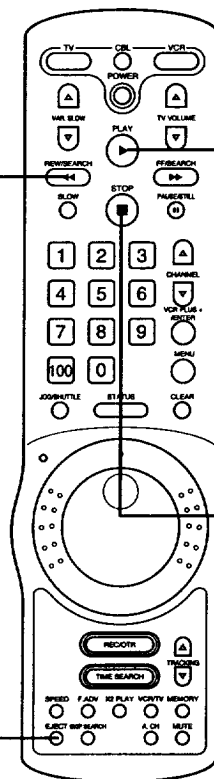

6 Press the EJECT or STOP/EJECT button to remove the tape.

3 To start playback, press the PLAY button.

4 To stop playback, press the STOP or STOP/EJECT button.

Remote Control

- If the tape you want to play is already in the VCR, just press the PLAY button.
- Playback options are on pages 29 - 32.

Recording

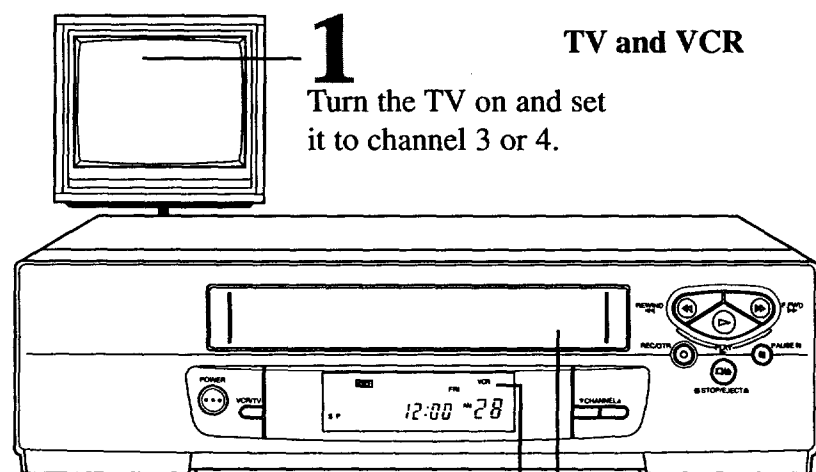

1 TV and VCR

Turn the TV on and set it to channel 3 or 4.

3 Make sure the VCR light is on.

2 Insert a tape.

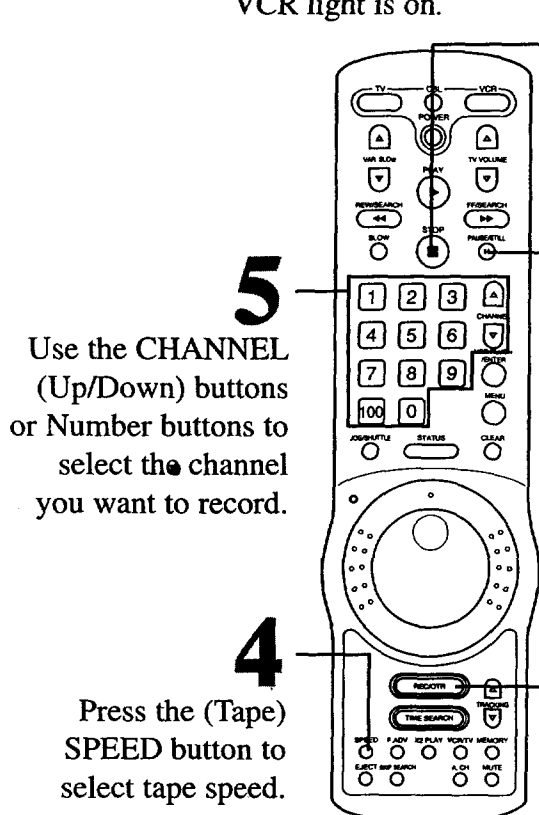

5 Use the CHANNEL (Up/Down) buttons or Number buttons to select the channel you want to record.

4 Press the (Tape) SPEED button to select tape speed.

8 To stop recording, press the STOP button.

7 Press the PAUSE/STILL button to pause recording. To start recording again, press the PAUSE/STILL button again.

6 Press the REC(ord)/OTR button once to start recording.

Remote Control

Read and follow the steps below to record a television program.

1 Turn the TV on and set it to channel 3 or 4, whichever the CH3/CH4 switch on the back of the TV is set to.

2 Insert a tape with its record tab intact (see page five) in the VCR. The power will come on, and the Cassette-Inside light will appear.

3 If the VCR light on the display panel of the VCR appears, go to step 4. If the VCR light does not appear, press the VCR/TV button once.

4 Press the (Tape) SPEED button on the remote control until the desired tape speed (see page five) appears on-screen.

5 Use the CHANNEL (Up/Down) buttons or Number buttons to select the channel to be recorded.

6 Press the REC(ord)/OTR button once to start recording.

7 To pause the recording (for example, during commercials), press the PAUSE/STILL button. To start recording again, press the REC(ord)/OTR button or the PAUSE/STILL button again.

8 To stop recording, press the STOP button.

- If the REC(ord)/OTR button is pressed while a tape without a record tab is in the VCR, PROTECTED CASSETTE CANNOT RECORD will appear on-screen, and the VCR will eject the tape.
- Recording options are on pages 17 - 25.
- You can change the tape speed while the VCR is recording, but some distortion will appear on the tape.

Setting the Clock

Follow the steps below to set your VCR's clock. Make sure:

- The VCR is on and in VCR position (see page 13).
- You make each entry within 60 seconds of the previous entry (otherwise, the VCR will exit Clock Set mode and you will have to start over).

1

Press the MENU button to bring up the main menu display.

TO SELECT PUSH NO. SHOWN

- 1 PROGRAM
- 2 VCR SET UP
- 3 TUNER SET UP
- 4 CLOCK SET
- 5 DAYLIGHT SAV. TIME

TO END PUSH MENU

2

Press the Number 4 button to select CLOCK SET.

TIME ---:--
DATE --:--

TO END PUSH MENU

3

Press two Number buttons for the hour(s) and two Number buttons for the minute(s). Then press 1 for AM or 2 for PM. For example, for 2:15 PM, press 02, 15, 2.

- Enter a 0 before single digit numbers.
- Entries that do not match the clock's internal calendar will cause a question mark (?) to appear on-screen.
- To make corrections, press the CLEAR button until the number you want to correct is flashing. Then enter the correct number.

TIME 02:15 PM
MONTH ---

TO CORRECT PUSH CLEAR
TO END PUSH MENU

4

Press two Number buttons for the month, two Number buttons for the day, and two Number buttons for the year. For example, for July 1, 1995, press 07, 01, 95. The day of the week will appear automatically.

TIME 2:15 PM
DATE 07/01/95
SAT.

TO CORRECT PUSH CLEAR
TO END PUSH MENU

5

Press the MENU button to start the clock. The screen will return to the program you were watching.

Remote Control

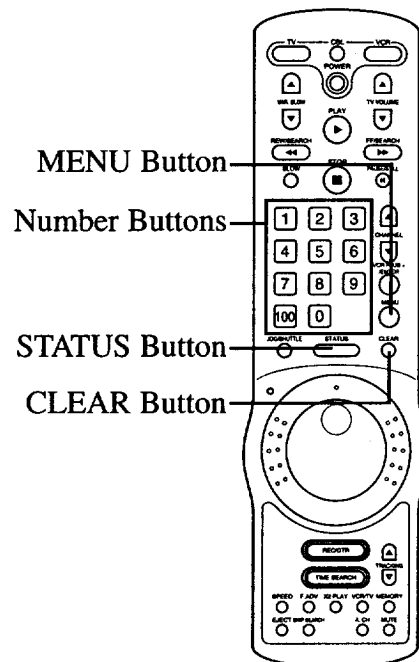

- To reset the clock, follow the steps above.
- To display the time, press the STATUS button. A status display, which includes the time, will appear on-screen. For details, see "On-Screen Displays" on page 11.
- Power failures for more than one minute can cause you to lose your clock setting as well as programmed channels. If this happens, follow the steps on pages seven and ten.
- If the numbers entered do not match the VCR's internal calendar, the entry will be rejected and a question mark (?) will appear on-screen.
- If you press the MENU button while you are setting the clock, the on-screen will return to the program you were watching. If this happens, start over.

On-Screen Displays

VCR Status Display Screen

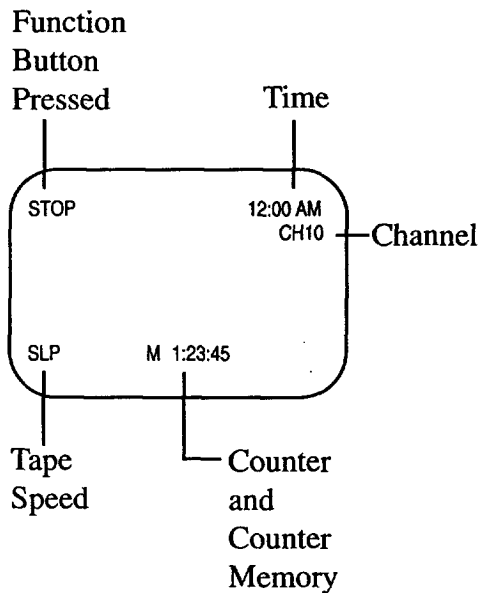

VCR Status Display

A status display, which includes the current time, channel, and other information (see illustration of the status display at left), will appear when you press the STATUS button or when certain function buttons are pressed. You can choose when you want the status display to appear and for how long it will appear.

ON SCREEN ON:

- Whenever you press a function button (STOP, FF, etc.), the status display will appear for five seconds.

COUNTER ONLY:

- Whenever you press a function button (STOP, FF, etc.), the status display will appear for five seconds. After five seconds, only the counter information will remain on-screen. You must press the STATUS button to remove it.

ON SCREEN OFF:

- The status display will not appear when you press function buttons.

To choose the status display mode:

1

Press the MENU button to bring up the main menu display.

2

Press the Number 2 button to select VCR SET UP.

TO SELECT PUSH NO. SHOWN

- 1 NORMAL PLAY ON
- 2 REPEAT PLAY
- 3 ON SCREEN MODE
- 4 LANGUAGE
- 5 GUIDE CHANNEL SET
- 6 GUIDE CHANNEL MAP

TO END PUSH MENU

3

Press the Number 3 button to select ON SCREEN MODE.

TO SELECT PUSH NO. SHOWN

- 1 ON SCREEN ON ON
- 2 COUNTER ONLY
- 3 ON SCREEN OFF

TO END PUSH MENU

4

Press the Number 1 button to select ON SCREEN ON, the Number 2 button to select COUNTER ONLY, or the Number 3 button to select ON SCREEN OFF. ON will appear beside the selected status display mode.

- If the channel you select has no broadcast, the screen will become a solid blue field. The screen will remain blue until you select an active channel.
- You may bring up the status display at any time by pressing the STATUS button. (The exception is when viewing a still picture or a slow motion picture, or when the FF/SEARCH or REW(ind)/SEARCH button is pressed during playback.)
- Channel numbers (when tuned) are displayed as an overlay for a few seconds.

Remote Control Buttons

TV Button
Press to operate the TV controls.
Details are on page 33.

SLOW and VAR(iable) SLOW Buttons
When playing a tape recorded in SP, LP or SLP speed, press the SLOW button to view the picture in slow motion. Then vary the speed from 1/6 to 1/30 of normal speed using the VAR(iable) SLOW button. *Details are on page 31.*

REW(ind)/SEARCH Button
When in Stop mode, press to rewind the tape at high speed. When in Play mode, press to rewind while the picture stays on-screen.

Number Buttons
Use to select channels and on-screen menus, and to program VCR functions (such as setting the clock).

Channels 1 - 9 ●
To select, press 0, then press the channel you want to select. For example, to select channel 7, press 0, 7.

Channels 100 and above ●
To select, press the 100 button, then press the last two digits of the channel you want to select. For example, to select channel 117, press 100, 1, 7.

JOG/SHUTTLE Button
Press to use the Jog Dial or the Shuttle Ring. *For details, see page 31.*

Jog/Shuttle Light
Lights up when the JOG/SHUTTLE button is pressed.

Jog Dial
When you turn this dial in either direction while in the Still mode, the tape moves forward or backward frame-by-frame at a speed that corresponds to the speed at which the dial is turned. *For details, see page 31.*

Shuttle Ring
Turn in either direction while in the Play or Still mode to vary search speed. The farther the ring is rotated, the faster the search speed. *For detail, see page 31.*

TIME SEARCH Button
Press to select the time counter number to which you want the tape automatically to forward or rewind. *Details are on page 29.*

(Tape) SPEED Button
Press to select recording speed (SP, LP or SLP).

EJECT Button
Press to eject the tape.

F(rame) ADV(ance) Button
Press when in Still mode to advance the picture one frame at a time.
Details are on page 31.

SKIP SEARCH Button
Press during playback to skip forward 30 seconds of the tape. Press up to six times in a row to skip up to three minutes of the tape.

CBL Button
Press to operate the Cable Converter controls.
Details are on page 34.

X2 PLAY Button
When in Play mode, press to watch a tape at two times normal playback speed.
Details are on page 31.

NOTES

Shaded boxes indicate TV control and cable converter box control buttons. They may or may not operate your TV or cable converter box. See pages 33 and 34 for details.

- Press the VCR button on the remote control before pressing other VCR operation buttons on the remote control.
- Press the TV button on the remote control before pressing other TV control buttons on the remote control.

Remote Control Buttons (cont'd)

STOP Button

Press to stop the tape.

VCR Button

Press to operate the VCR controls.

PLAY Button

Press to play a tape. Also, press to release Search, Slow or Still mode and return to normal playback (see page 31 for details).

FF/SEARCH Button

When in Stop mode, press to fast forward the tape at high speed. When in Play mode, press to fast forward while the picture stays on-screen.

PAUSE/STILL Button

In Record mode, press to temporarily stop the recording (pause). In Play mode, press to freeze the picture (still). Press a second time to resume normal recording or playback. Details are on page 31.

VCR PLUS+/ENTER Button

Press to start a VCR Plus+ Timer Recording. Details are on pages 22-25.

MENU Button

Press to bring up the main menu display.

CLEAR Button

Press to erase incorrect data when programming VCR functions. Also, press to reset the tape counter (0:00:00 will appear on-screen and on the VCR display panel).

STATUS Button

Press to display the time counter, time, current VCR function, and channel. Details are on page 11.

REC(ord)/OTR Button

Press to once start a recording (see page nine for details). Or, press three to ten times to start a one touch recording (an immediate timed recording, 30 minutes to four hours long) of the channel you are watching (see page 18 for details).

TRACKING (Up/Down) Buttons

When in Play or Slow mode, press to adjust the tracking. Details are on page 32

MEMORY Button

Press to memorize a tape position at which the counter was set to 0:00:00. Details are on page 30.

VCR/TV Button

Use to select the signal source that your TV receives.

● **VCR Position**

Use to watch a tape, monitor a recording, or watch a TV broadcast using the CHANNEL (Up/Down) or Number buttons.

● **TV Position**

Use to watch TV or to watch one program while recording. Details are on page

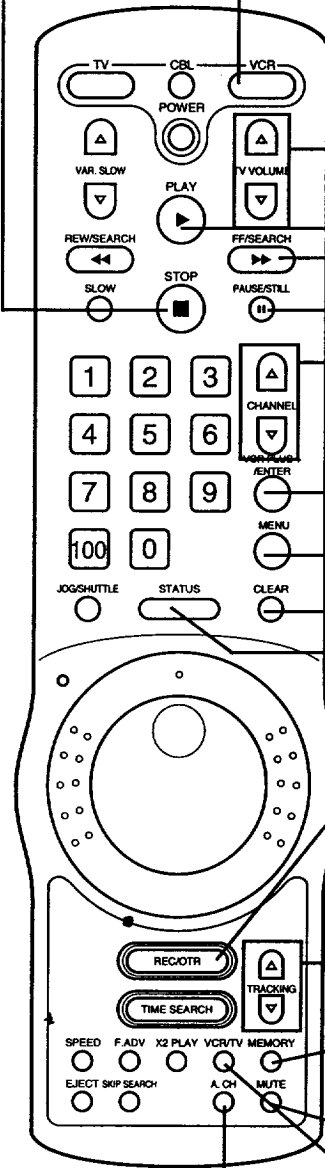

TV Button
Press to return to the TV signal. Press again to return to the previous volume level.

Press to eliminate the TV sound. Press again to return to the previous volume level.

NOTES

Shaded boxes indicate TV control and cable converter box control buttons. They may or may not operate your TV or cable converter box. See pages 33 and 34 for details.

- Press the VCR button on the remote control before pressing other VCR operation buttons on the remote control.
- Press the TV button on the remote control before pressing other TV control buttons on the remote control.

Display Panel

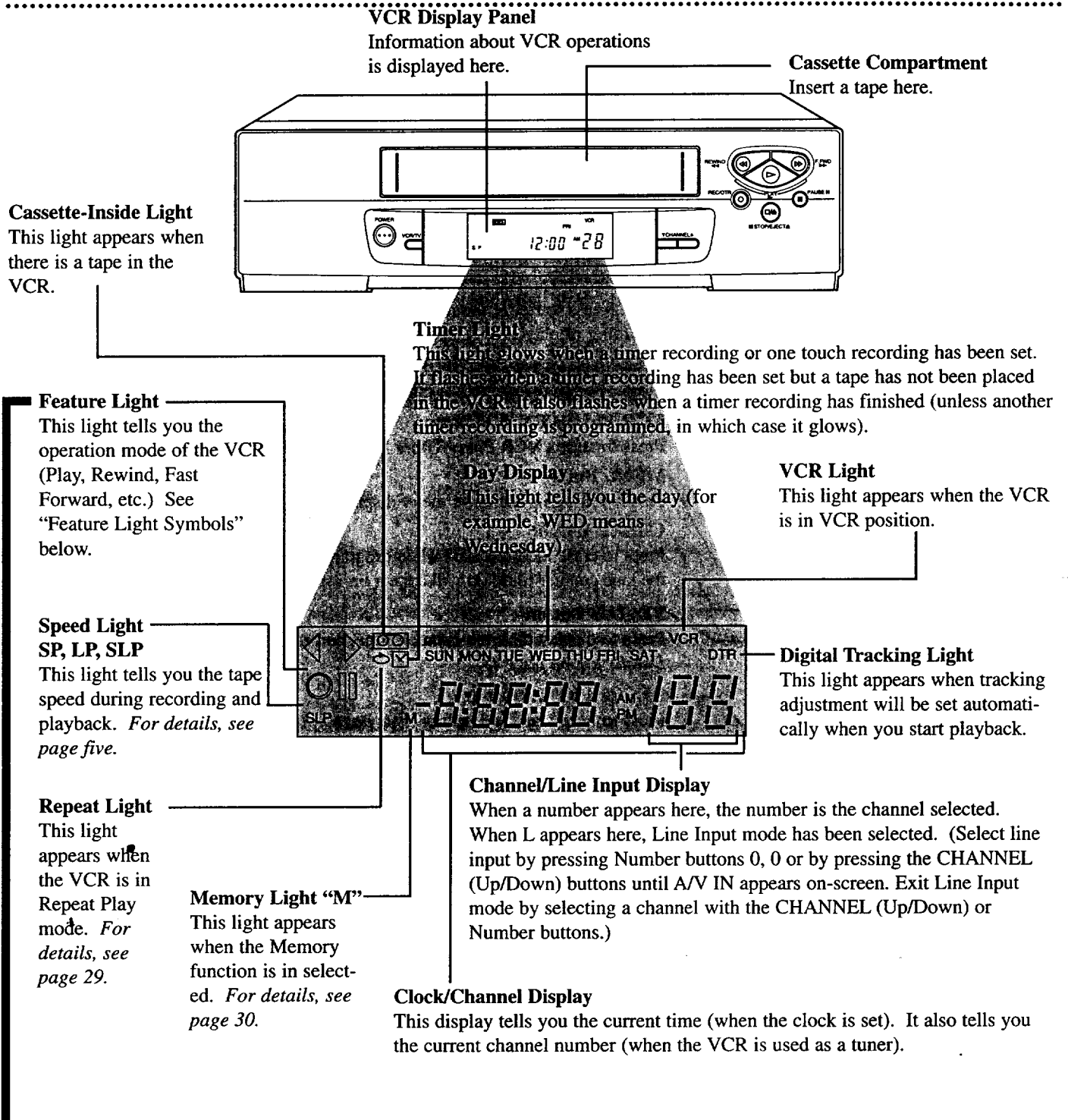

Feature Light Symbols

The symbols will appear on the display panel to indicate the current mode or operation of the VCR.

▷	Play Mode	⊙	Record Pause Mode
◁	Reverse Play Mode	▯	Still Mode
◁-	Rewind/Search Mode	- ▯	Eject Mode
- ▷	Fast Forward/Search Mode X2 Play Mode	▷	Slow/F.Advance Mode
⊙	Record Mode	◁	Reverse Slow Mode Reverse F.Advance Mode

Front Panel

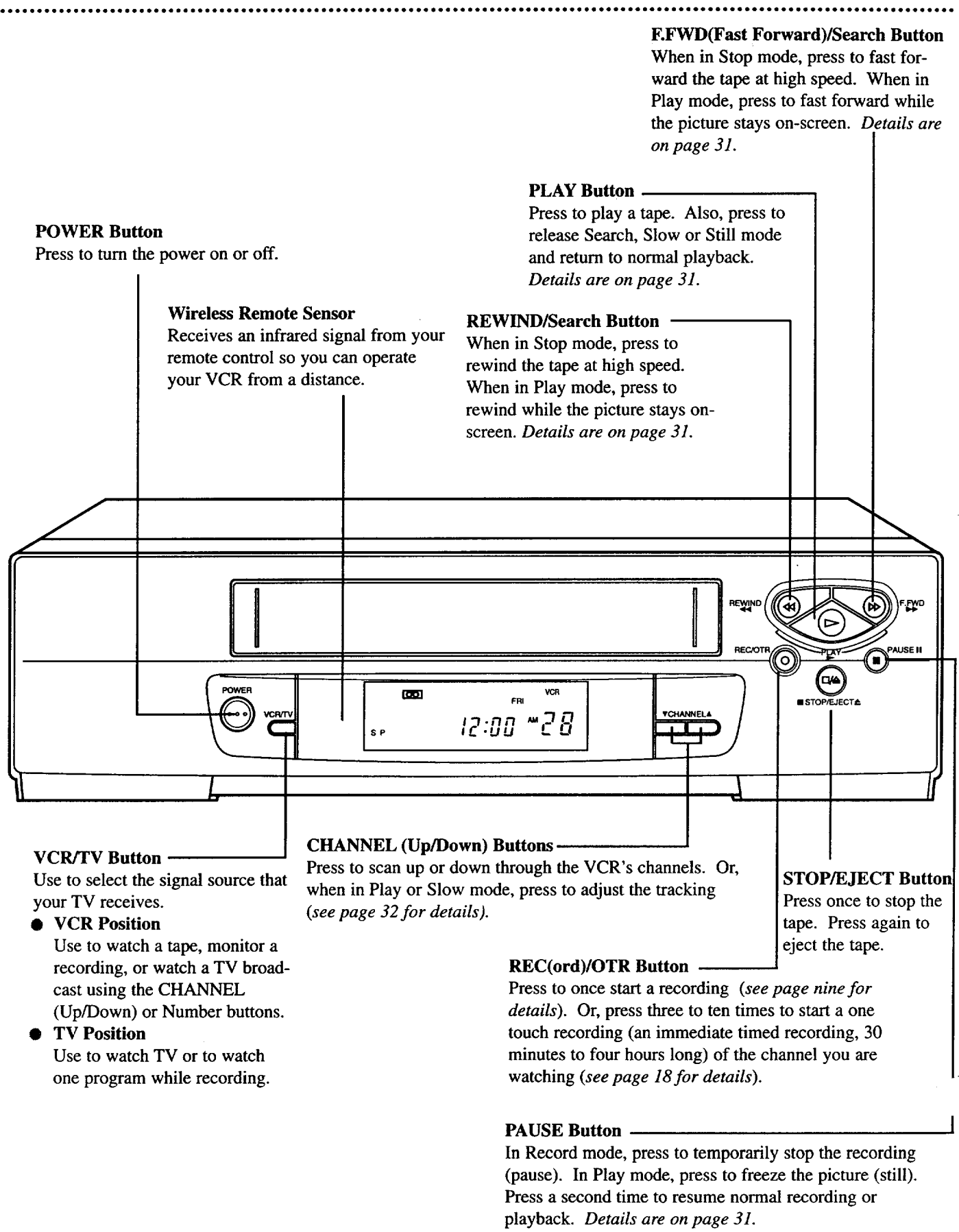

POWER Button

Press to turn the power on or off.

Wireless Remote Sensor

Receives an infrared signal from your remote control so you can operate your VCR from a distance.

PLAY Button

Press to play a tape. Also, press to release Search, Slow or Still mode and return to normal playback.

Details are on page 31.

REWIND/Search Button

When in Stop mode, press to rewind the tape at high speed. When in Play mode, press to rewind while the picture stays on-screen. *Details are on page 31.*

F.FWD(Fast Forward)/Search Button

When in Stop mode, press to fast forward the tape at high speed. When in Play mode, press to fast forward while the picture stays on-screen. *Details are on page 31.*

VCR/TV Button

Use to select the signal source that your TV receives.

● **VCR Position**

Use to watch a tape, monitor a recording, or watch a TV broadcast using the CHANNEL (Up/Down) or Number buttons.

● **TV Position**

Use to watch TV or to watch one program while recording.

CHANNEL (Up/Down) Buttons

Press to scan up or down through the VCR's channels. Or, when in Play or Slow mode, press to adjust the tracking (*see page 32 for details*).

REC(ord)/OTR Button

Press to once start a recording (*see page nine for details*). Or, press three to ten times to start a one touch recording (an immediate timed recording, 30 minutes to four hours long) of the channel you are watching (*see page 18 for details*).

STOP/EJECT Button

Press once to stop the tape. Press again to eject the tape.

PAUSE Button

In Record mode, press to temporarily stop the recording (pause). In Play mode, press to freeze the picture (still). Press a second time to resume normal recording or playback. *Details are on page 31.*

16

Rear Panel

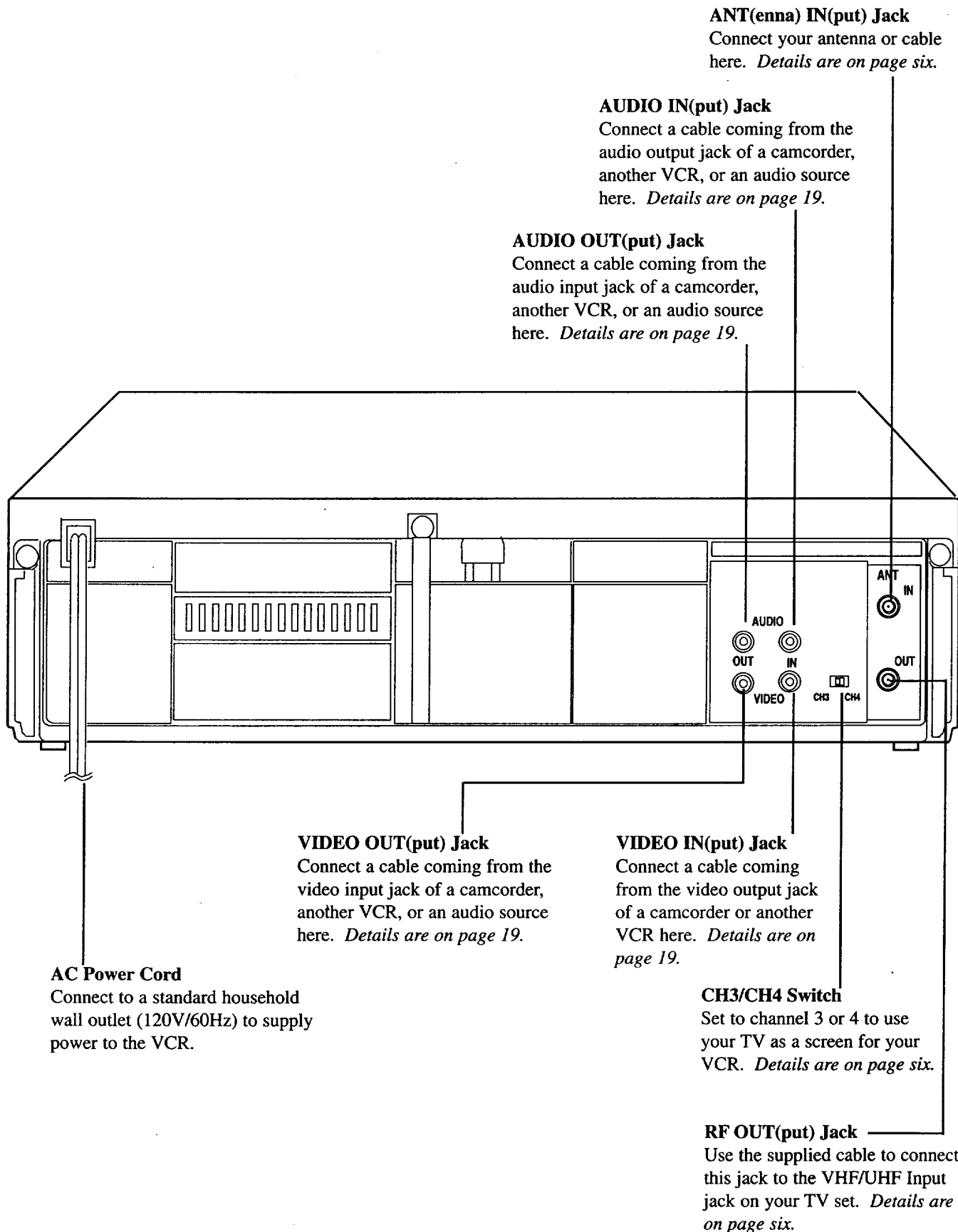

Recording One Channel/Watching Another

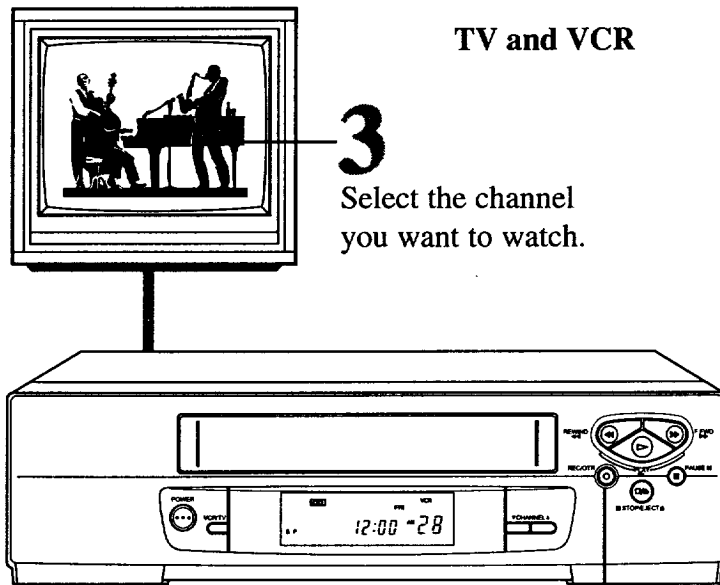

TV and VCR

3
Select the channel you want to watch.

1
Start a recording.

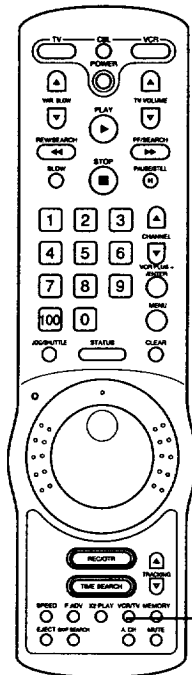

Remote Control

2
Put the VCR in TV position.

1

Start a recording (see page nine).

2

Press the VCR/TV button to put the VCR in TV position. The VCR light will disappear from the VCR's display panel.

3

Use the TV remote control to select the channel you want to watch.

4

To return to the channel being recorded, use the TV remote control or the TV to select channel 3 or 4 (see page six for details). Press the VCR/TV button to put the VCR in VCR position. The channel being recorded will appear on-screen.

NOTE: If a blue screen appears instead of the desired channel, press the CHANNEL (Up/Down) buttons to select an active channel.

- If you use a converter box or satellite system hookup, you may not be able to watch one channel while recording another. See page 39 for details.
- If you don't receive channels, please repeat the steps on page six, then follow the instructions above carefully.

One Touch Recording

The one touch recording (OTR) function allows you to program an immediate timed recording 30 minutes to four hours long without setting the timer. Before you begin, make sure:

- Channels have been programmed.
- The desired recording speed (SP, LP, SLP) has been selected with the (Tape) SPEED button.
- There is a tape in the VCR (make sure the tape's record tab is intact and the tape is long enough to record the program(s)).
- The VCR is in VCR position.

Starting an OTR

1

Use the CHANNEL (Up/Down) buttons or Number buttons to select the channel you want to record.

2

Press the REC(ord)/OTR button twice. The screen below will appear.

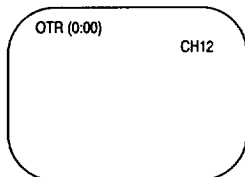

3

Press the REC(ord)/OTR button until the desired recording length (30 minutes to four hours) is in the upper left corner of the screen. Recording will begin immediately.

Stopping an OTR

To stop an OTR before recording is finished, press the STOP button or the POWER button. To cancel the OTR but continue recording, press the REC(ord)/OTR button repeatedly until REC appears on-screen.

Remote Control

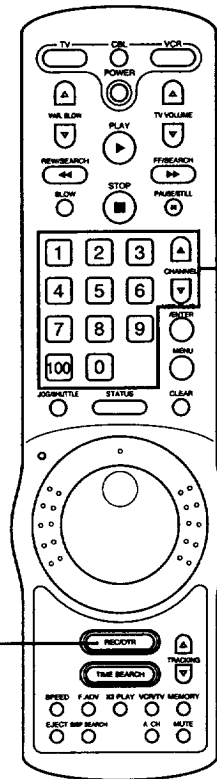

1 Use the CHANNEL (Up/Down) button or Number buttons to select the channel you want to record.

2 Press the REC(ord)/OTR button three to ten times to start an OTR and select a recording length.

- To check the time remaining for an OTR after the OTR has been set, press the STATUS button.
- To change the recording length while an OTR is in progress, press the REC(ord)/OTR button until the desired length is displayed on-screen.
- If you begin an OTR when a recording is paused, the OTR will begin.
- You can not pause the recording (for example, during commercials), during an OTR mode.
- If the preset time for a timer recording comes up during an OTR, the OTR has priority.

Rerecording (Tape Duplication)

Connections

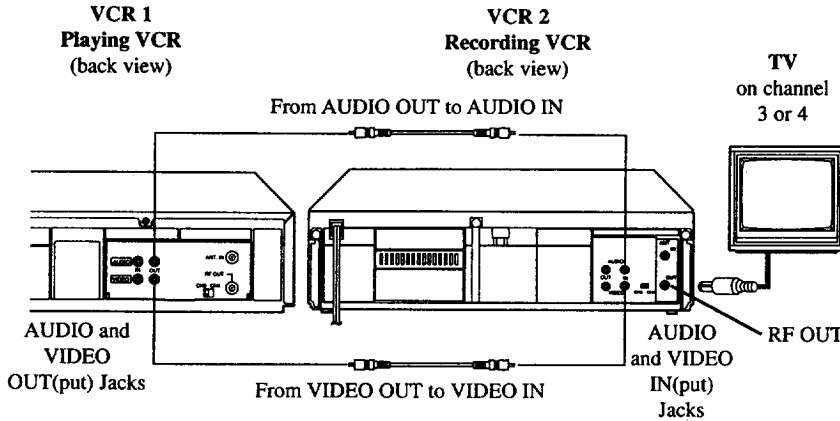

Audio and video cables are not included.

Operation

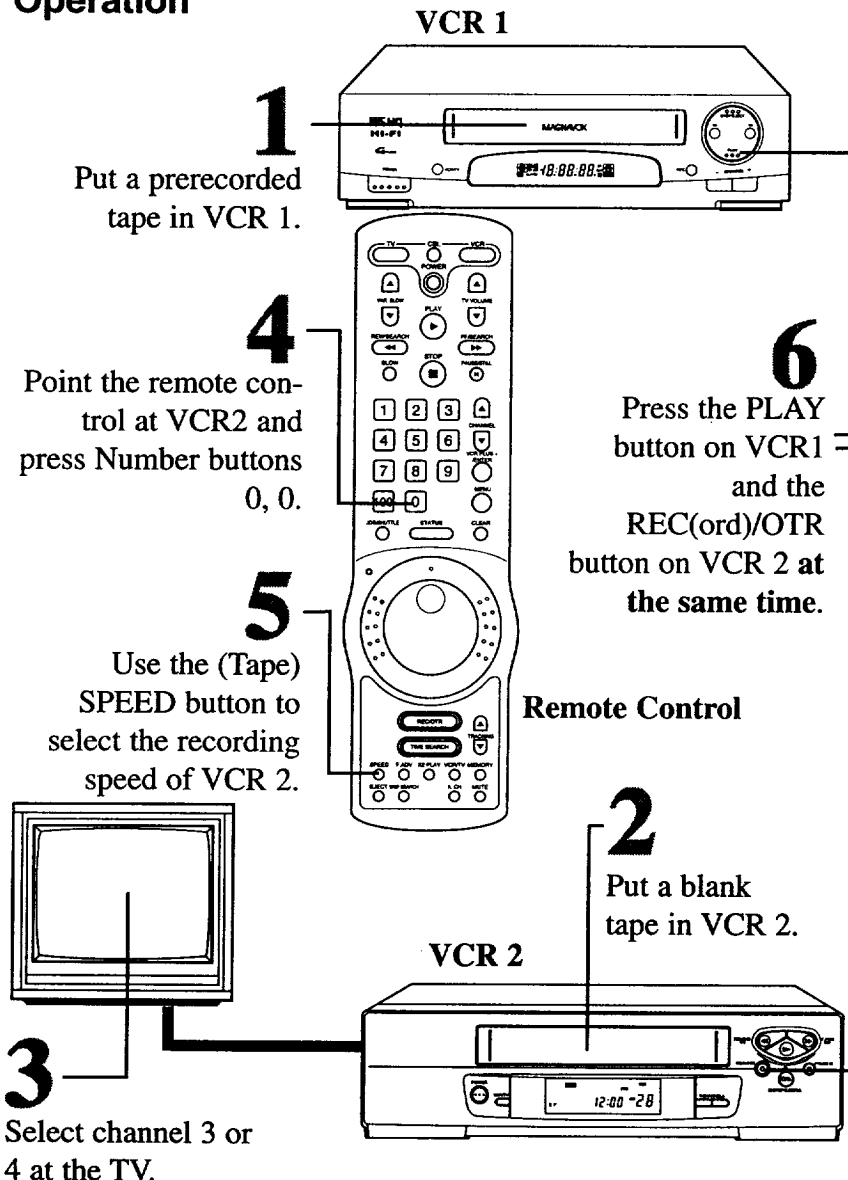

The instructions on this page show you how to copy tapes. The illustration uses two VCRs just like yours. Different VCRs may operate differently.

NOTE: Unauthorized recording of copyrighted television programs, video tapes, or other materials may infringe on the rights of copyright owners and violate copyright laws.

1 VCR 1 will play your tape. Insert a prerecorded tape in VCR 1. If the tape does not have a record tab, playback begins. If this happens, press the STOP/EJECT button on the VCR 1.

2 VCR 2 will record your tape. Insert a blank tape in VCR 2. Make sure the power is on and VCR 2 is in VCR position.

3 Turn the TV on and put it on channel 3 or 4, whichever channel to which the CH3/CH4 switch on VCR 2 is set (see page seven).

4 Point the remote control at VCR 2. Press Number buttons 0, 0. A/V IN will appear on-screen and L will appear on the display panel of the VCR.

5 Point the remote control at VCR 2. Use the (Tape) SPEED button to select SP, LP or SLP.

6 Press the PLAY button on VCR 1 and the REC(ord)/OTR button on VCR 2 at the same time.

Timer Recording

Follow the steps below to program your VCR to record TV programs while you're away from home. You can program up to eight timer recordings. For each one, the VCR will turn itself on, record, and turn itself off automatically. Before you begin make sure:

- Channels have been programmed.
- The clock has been set.
- There is a tape in the VCR (make sure the tape's record tab is intact and the tape is long enough to record the program(s)).
- The VCR is in VCR position.

You must do each step within 60 seconds of completing the previous step. If you don't, you will have to start again at step 1.

1

Press the MENU button to bring up the main menu display.

TO SELECT PUSH NO. SHOWN

- 1 PROGRAM
- 2 VCR SET UP
- 3 TUNER SET UP
- 4 CLOCK SET
- 5 DAYLIGHT SAV. TIME

TO END PUSH MENU

2

Press the Number 1 button on the remote control to select PROGRAM.

TO SELECT PUSH NO. SHOWN

- 1 ONCE
- 2 DAILY
- 3 WEEKLY
- 4 PROGRAM REVIEW

TO END PUSH MENU

3

Select a once, daily or weekly recording.

- Press the Number 1 button to select ONCE. The VCR will record a TV program on any day you choose, up to 12 months away.
- Press the Number 2 button to select DAILY. The VCR will record from Monday to Friday – starting at the same time and for the same length of time.
- Press the Number 3 button to select WEEKLY. The VCR will record on the same day, at the same time, and for the same length every week.

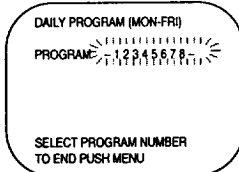

Daily Recording Menu Screen

4

Use the Number buttons (1 - 8) to select a position in which to store the timer recording. Flashing numbers indicate an open position (one in which a timer recording has not yet been stored).

NOTE: If you select a number that has already been used to store a timer recording, PREVIOUSLY SET PROGRAM will appear on-screen for a few seconds. Then information about the program in that position will be displayed on-screen. If this happens, press the MENU button twice. Then start again at step 1.

5

- If you are using a standard antenna to VCR to TV hookup, enter the channel of the TV program you want to record (you must enter a 0 before all single digit channels).
- If you are recording from line input, press 0, 0. A/V IN will appear on-screen.
- If you are recording using a cable converter box, see pages 38 - 39.

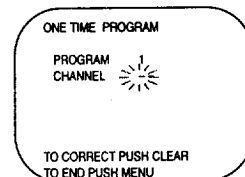

6

Press two Number buttons for the hour(s) you want the recording to begin. Press two number buttons for the minute(s) you want the recording to begin. Press 1 for AM or 2 for PM. For example, for 9:30 PM, press 09, 30, 2.

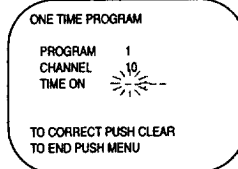

7

Follow the instructions in step 6 to set the recording's stop time (AM or PM will be set automatically).

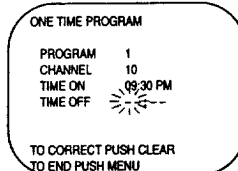

Timer Recording (cont'd)

8

Press the Number 1 button to record in SP speed, press the Number 2 button to record in LP speed, or press the Number 3 button to record in SLP speed. For details, see page five. You cannot use the (Tape) SPEED button at this time.

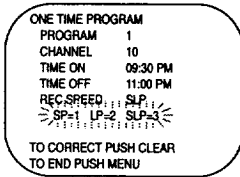

9

Press two Number buttons for the day and the month you want the program to record. For example, for July 10, 1995, press 07, 10. The day of the week and year will be displayed automatically (you cannot program the VCR to record more than one year in advance).

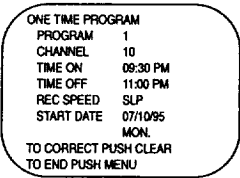

10

Press the MENU button. PROGRAM WAS COMPLETED / PLEASE TURN OFF VCR FOR TIMER RECORDING will appear on-screen (if PROGRAM NOT COMPLETED appears, try again from step 1). In three seconds the on-screen display will disappear. Now, go to steps 11 and 12.

11

If you want to program another timer recording, press the MENU button. Repeat steps 2 - 10. If you don't want to program another timer recording, go to step 12.

12

Turn off the VCR power. The Timer light will appear. The VCR must be turned off for a timer recording to take place. If you forget to turn the VCR off, PLEASE TURN OFF VCR FOR TIMER RECORDING flashes on your TV screen two minutes before a timer recording starts. You can remove it by pressing the CLEAR button.

The VCR must be off for a timer recording to take place!

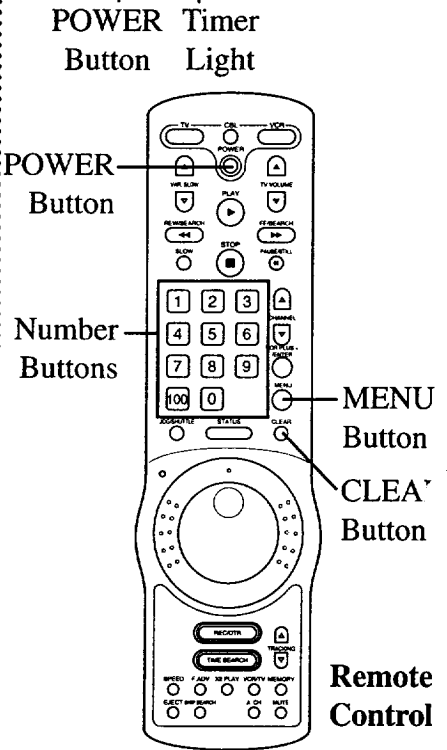
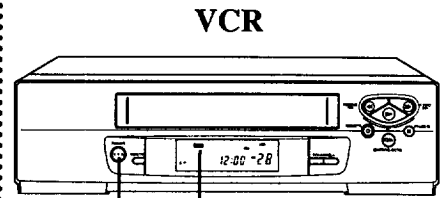

- **PROGRAM NOT COMPLETED** may appear and CLASH may flash on the screen when you finish setting a timer recording. This means that the timer recording you just programmed and another timer recording overlap, and thus the current timer recording will not be carried out.
- If the preset time for a timer recording comes up during an OTR, the OTR has priority.
- To stop a started timer recording, press the STOP/EJECT button on the VCR.
- If the power fails for more than one minute, programmed timer recordings may be lost. If this case, repeat the steps on pages seven and ten before re-programming the timer recordings. Please see page 35 for more notes.

Setting Up VCR Plus+ (cont'd)

2

Now, compare the channel numbers you have written into the GUIDE CH. and USER CH. columns. You'll notice that some stations have guide and user channel numbers that are the same, and other stations have channel numbers that do not match. Where the channel numbers DO NOT match, you must tell the VCR the guide and user channel numbers according to the steps below.



3

Press the MENU button, then press the Number 2 button to select VCR SET UP.

TO SELECT PUSH NO. SHOWN
 1 NORMAL PLAY ON
 2 REPEAT PLAY
 3 ON SCREEN MODE
 4 LANGUAGE
 5 GUIDE CHANNEL SET
 6 GUIDE CHANNEL MAP
 TO END PUSH MENU

4

Press the Number 5 button to select GUIDE CHANNEL SET.

GUIDE CHANNEL SET
 SELECT GUIDE CH. NO.
 GUIDE CH. 
 USER CH. 

TO END PUSH MENU

5

Look at the boxes you filled in on pages 22 - 23. For stations whose guide channels and user channels are not the same, press two Number buttons for the guide channel and two Number buttons for the user channel.

- Always enter "0" before any single digit channels.
- If you select line input for the user channel, press 0, 0. AUX will appear on-screen.

GUIDE CHANNEL SET
 SELECT USER CH. NO.
 GUIDE CH. 28
 USER CH. 

TO CORRECT PUSH CLEAR
 TO END PUSH MENU

6

Press the Number 1 button so your VCR will memorize the guide channel and user channel numbers you have selected. Or, press the Number 2 button to quit and select another pair of numbers.

GUIDE CHANNEL SET
 TO SELECT PUSH. NUMBER
 GUIDE CH. 28
 USER CH. 04
 1 MEMORIZE
 2 SELECT ANOTHER CH.
 TO CORRECT PUSH CLEAR
 TO END PUSH MENU

7

Repeat steps 5 and 6 for all the stations on your list which have different guide channel and user channel numbers.

8

Press the MENU button to exit.

9

To confirm the guide channel and user channel numbers you have selected, press the MENU button to bring up the main menu display. Then press the Number 2 button to select VCR SET UP. Finally, press the Number 6 button to select GUIDE CHANNEL MAP. A list of guide channel and user channel numbers memorized by the VCR will appear on-screen. If there are more than ten pairs of numbers, press the Number 1 button to view another screen of numbers. Make sure these numbers correspond to the boxes you filled in in step 1. Then press the MENU button to exit.

GUIDE CHANNEL MAP
 GUIDE : USER GUIDE : USER
 01 : AUX 02 : 02
 03 : 03 04 : 04
 23 : 05 06 : 06
 07 : 07 08 : 08
 09 : 09 10 : 10
 TO CANCEL PUSH CLEAR
 NEXT=1 END=MENU

Remote Control

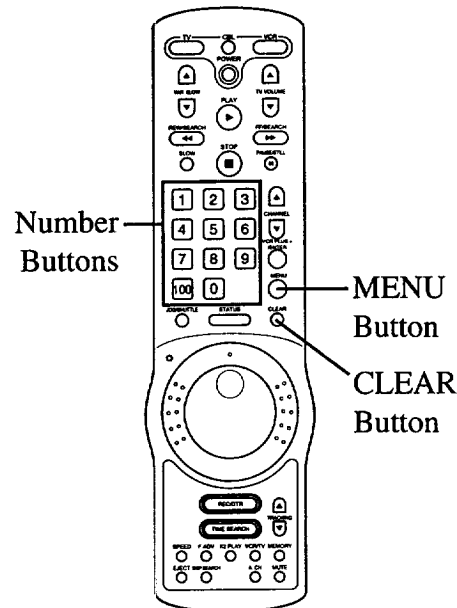

- **To correct a guide channel number:**
 1. Repeat steps 3 - 6 on this page.
 2. At step 5, enter the incorrect guide channel number for both the guide channel and the user channel. This will erase the incorrect guide channel.
 3. Repeat steps 3 - 6 again, this time entering the correct guide channel and user channel.
- **To correct a user channel number:**
 1. Repeat steps 3 - 6 on this page.
 2. At step 5, enter the correct guide channel and user channel numbers.
- **To cancel a pair of numbers:**
 1. Follow step 9 to display the guide channel map.
 2. Press the CLEAR button. A pair of numbers will flash.
 3. Press the CHANNEL (Up/Down) buttons until the pair of numbers you wish to cancel is flashing.
 4. Press the CLEAR button again. The pair of numbers that was flashing will disappear.
 5. Press the MENU button to exit.

Timer Recording With VCR Plus+

Remote Control

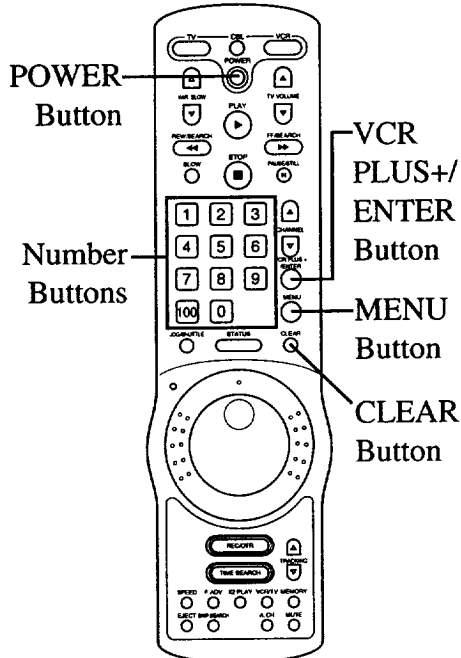

Read steps 1-7 to program a timer recording using VCR Plus+ numbers.

Before you begin make sure:

- Channels have been programmed.
- The clock has been set.
- There is a tape in the VCR (make sure the tape's record tab is intact and the tape is long enough to record the program(s).
- The VCR is in VCR position.
- You have selected CABLE TV or TV at the TUNER SET UP menu.

You must do each step within 60 seconds of completing the previous step. If you don't, you will have to start again at step 1.

1

Press the VCR PLUS+/ENTER button on the remote control. The on-screen display shown below will appear.

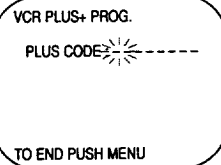

2

Press the Number buttons for the VCR Plus+ number of the program you wish to record (this number is different for every program, and it can be four to eight digits long). Finally, press the VCR PLUS+/ENTER button.

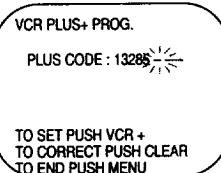

3

To record the program once, press the Number 1 button to select ONCE. To record the same program every day from Monday through Friday, press the Number 2 button to select DAILY. To record the same program every week on the same day (such as every Saturday), press the Number 3 button to select WEEKLY.

4

Press the Number 1 button to record in SP speed, press the Number 2 button to record in LP speed, or press the Number 3 button to record in SLP speed. For details, see page five. You cannot use the (Tape) SPEED button at this time.

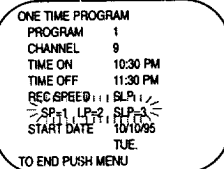

5

Press the MENU button. PROGRAM WAS COMPLETED / PLEASE TURN OFF VCR FOR TIMER RECORDING should appear on the screen. After three seconds, the on-screen display will disappear.

6

If needed, press the VCR PLUS+/ENTER button and repeat steps 2 to 5. When you are finished, go to step 7.

7

Turn off the VCR power. The Timer light will appear. The VCR must be turned off for a timer recording to take place. If you forget to turn the VCR off, PLEASE TURN OFF VCR FOR TIMER RECORDING flashes on your TV screen two minutes before a timer recording starts. You can remove it by pressing the CLEAR button.

- If **CODE ERROR** appears at step 2 after you enter the VCR Plus+ number, the number you entered was incorrect (for example, too short). If this happens, press the **CLEAR** button to clear the number, then enter the correct number.
- **CLASH** may flash on the screen at step 2. This means that the timer recording you just programmed and another timer recording overlap, and thus the current timer recording will not be carried out.
- To quit VCR Plus+ programming at any step, press the **MENU** button. The on-screen display will disappear from the TV screen.
- If the preset time for a timer recording comes up during an OTR, the OTR has priority.
- To stop a started timer recording, press the **STOP/EJECT** button on the VCR.
- If the power fails for more than one minute, programmed timer recordings may be lost. If this case, repeat the steps on pages seven and ten before re-programming the timer recordings.

See page 35 for more notes.

**The VCR
must be off for a
timer recording
to take place!**

Channel Memory

Programming Channels

Although your VCR automatically memorizes the channels you receive when you turn it on for the first time, this function lets you reprogram channels.

1

Press the MENU button to bring up the main menu display.

TO SELECT PUSH NO. SHOWN

- 1 PROGRAM
- 2 VCR SET UP
- 3 TUNER SET UP
- 4 CLOCK SET
- 5 DAYLIGHT SAV. TIME

TO END PUSH MENU

2

Press the Number 3 button to select TUNER SET UP.

TO SELECT PUSH NO. SHOWN

- 1 TV ON
- 2 CABLE TV
- 3 AUTO PROGRAMMING
- 4 ADD/DELETE CH
- 5 CH MEMORY REVIEW

TO END PUSH MENU

3

Press the Number 2 button if you have a cable. Press the Number 1 button if you are using an antenna. ON will appear beside TV or CABLE TV.

4

Press the Number 3 button to select AUTO PROGRAMMING. MEMORIZED CHANNEL / PLEASE WAIT will appear on-screen. The VCR will place all channels you receive into its memory.

5

Wait for a few minutes while the VCR programs channels. When programming is complete, AUTO SET COMPLETED will appear on-screen. Then the lowest channel number placed in the VCR's memory will appear on-screen. Now when you press the CHANNEL (Up/Down) buttons you will scan only through channels you receive.

Remote Control

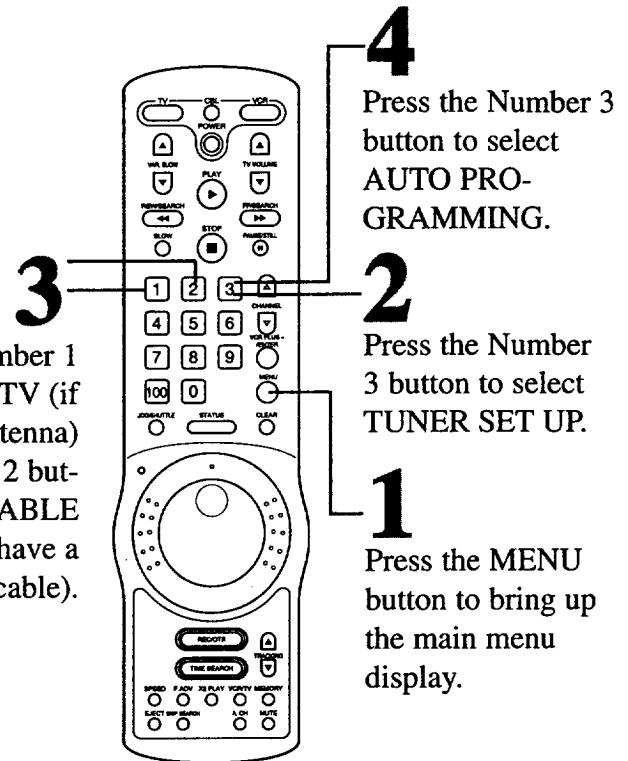

Press the Number 1 button to select TV (if you have an antenna) or the Number 2 button to select CABLE TV (if you have a cable).

Press the Number 3 button to select AUTO PROGRAMMING.

Press the Number 3 button to select TUNER SET UP.

Press the MENU button to bring up the main menu display.

Line Input mode will always be stored in the VCR's memory as channel 00. When you select channel 00 with the CHANNEL (Up/Down) buttons, A/V IN will appear on the screen and L will appear on the display panel of the VCR (see page 19 for details).

Channel Memory (cont'd)

Remote Control

3 Press the Number 4 button to select ADD/DELETE CH.

4 Use the Number buttons to enter the channel number you want to add or delete.

5 Press the Number 1 button to add that channel, the Number 2 button to delete that channel, or the Number 3 button to select another channel.

2 Press the Number 3 button to select TUNER SET UP.

1 Press the MENU button to bring up the main menu display.

6 Press the MENU button to exit.

Adding/Deleting Channels

- 1** Press the MENU button to bring up the main menu display.
- 2** Press the Number 3 button to select TUNER SET UP.
- 3** Press the Number 4 button to select ADD/DELETE CH.

SELECT CHANNEL NUMBER
 CH:
 TO END PUSH MENU
- 4** Enter the desired channel number (see "Number Buttons" on page 12).

TO SELECT PUSH NO. SHOWN
 CH12
 1 ADD
 2 DELETE
 3 SELECT ANOTHER CH
 TO END PUSH MENU
- 5** Press the Number 1 button to add that channel. Press the Number 2 button to delete that channel. Press the Number 3 button to delete that entry and select another channel.
- 6** Press the MENU button to exit.

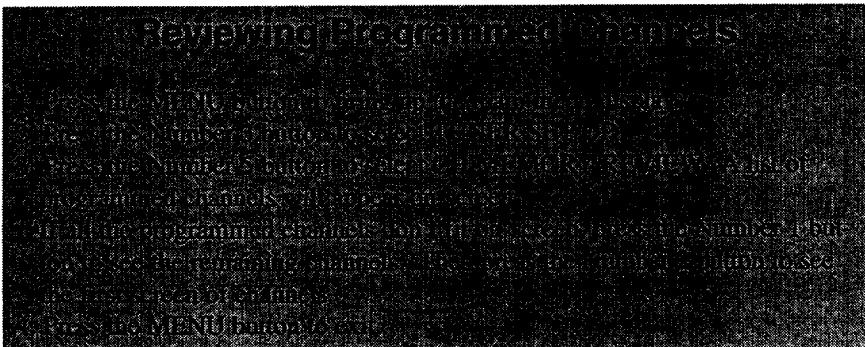

Language/Daylight-Saving Time Selection

Language Selection

Follow the steps below to change the language of the on-screen displays.

- 1** Press the MENU button to bring up the main menu display.
- 2** Press the Number 2 button to select VCR SET UP.
- 3** Press the Number 4 button to select LANGUAGE.
- 4** Press the Number 1 button if you want the on-screen displays in English. (ON) will appear to the right of ENGLISH on-screen. Press the Number 2 button if you want the on-screen displays in Spanish. (SI) will appear to the right of ESPAÑOL on-screen.
- 5** Press the MENU button to exit.

Daylight-Saving Time Selection

Follow the steps below to program the VCR so its clock automatically will move forward one hour in April and turn back one hour in October.

- 1** With the clock set, press the MENU button to bring up the main menu display.
- 2** Press the Number 5 button to select DAYLIGHT SAV. TIME.
- 3** Press the Number 1 button to select ON (or the Number 2 button to select OFF). ON will appear to the right of SELECT D.S.T. on-screen.

4

Language Selection

1 Press the MENU button to bring up the main menu display.

2 Press the Number 2 button to select VCR SET UP.

3 Press the Number 4 button to select LANGUAGE.

4 Press the Number 1 button if you want the on-screen displays in English. Press the Number 2 button if you want the on-screen displays in Spanish.

5 Press the MENU button to exit.

Remote Control

Daylight-Saving Time Selection

1 Press the MENU button to bring up the main menu display.

2 Press the Number 5 button to select DAYLIGHT SAV. TIME.

3 Press the Number 1 button to select ON (or the Number 2 button to select OFF).

4 Press the MENU button to exit.

Remote Control

Playback Options

Repeat Playback

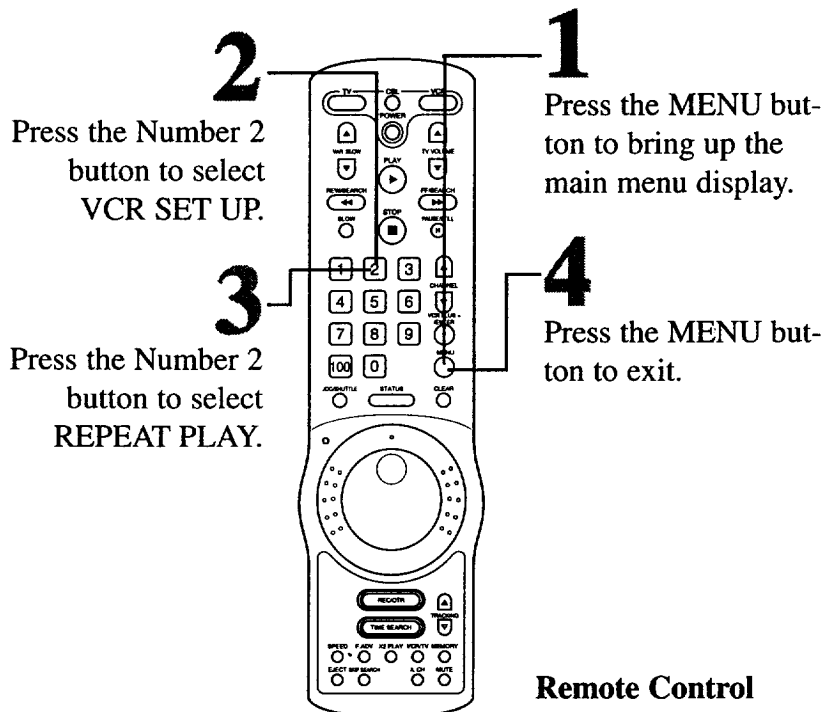

Repeat Playback

Follow the steps below to program the VCR to play a tape over and over.

- 1** Press the MENU button to bring up the main menu display.
- 2** Press the Number 2 button to select VCR SET UP.
- 3** Press the Number 2 button to select REPEAT PLAY. ON will appear on-screen to the right of REPEAT PLAY.
- 4** Press the MENU button to exit. Now, when a tape has finished playing, the VCR will rewind it and start playback again.

Time Search

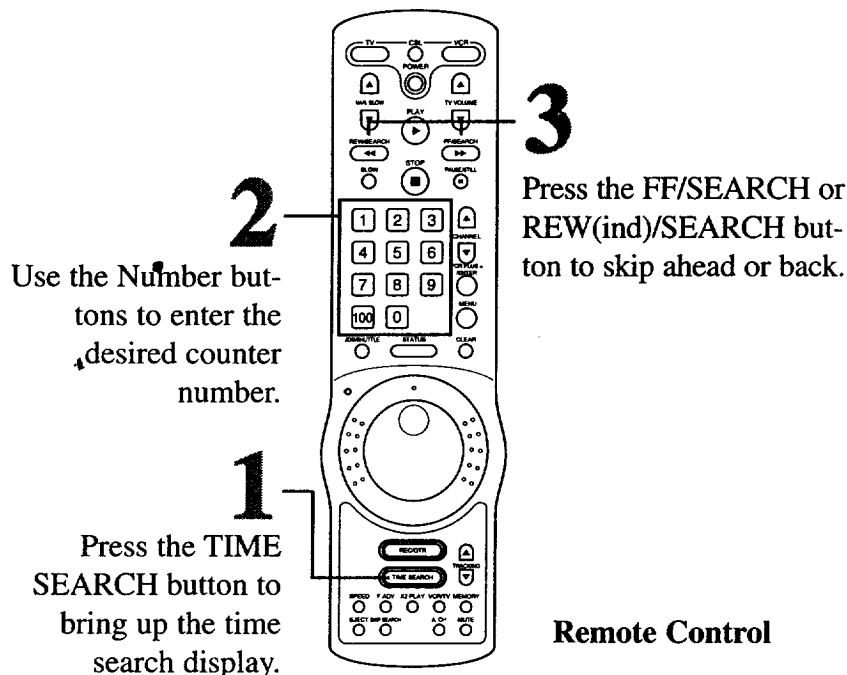

Time Search

Follow the steps below to program the VCR to go to a place on a tape with a specified time counter number.

- 1** While in Stop mode, press the TIME SEARCH button to bring up the time search display.
- 2** Press the Number buttons to enter the desired length of time you want to skip back or ahead. For example, for 1 hour 25 minutes, press Number buttons 1, 2, 5. Or, for five minutes, press Number buttons 0, 0, 5. (You must make an entry within 10 seconds of pressing the TIME SEARCH button. Otherwise, the VCR will cancel Time Search mode.)
- 3** Press the FF/SEARCH or REW(ind)/SEARCH button to skip ahead or back. The VCR will skip over the desired length of time and begin playback.

- The VCR will stay in Repeat Play mode until you cancel Repeat Play mode. To do this, follow steps 1 - 2 under "Repeat Playback". At step three, press the Number 1 button to select NORMAL PLAY.
- The time counter memory does not function when the VCR is in Repeat Play mode.
- You can exit Time Search mode by pressing the TIME SEARCH button. To cancel Time Search mode when the VCR is fast forwarding or rewinding, press the STOP button.

Playback Options (cont'd)

Time Counter Memory

Follow the steps below to reset the time counter to zero at tape locations you want to refer to later.

1

Press the STATUS button. The time counter display will appear on-screen.

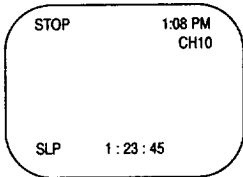

2

Play, fast forward, or rewind a tape to the location that you would like to refer to later.

3

Press the CLEAR button to reset the time counter to zero.

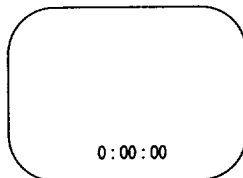

4

Press the MEMORY button to memorize the tape location. M will appear on-screen.

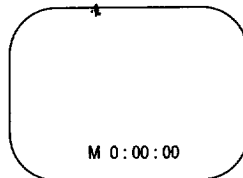

5

To return to the previous point at which the time counter was reset to zero: when in Stop mode, press the REW(ind)/SEARCH button. To return to the next point at which the time counter was reset to zero: when in Stop mode, press the FF/SEARCH button.

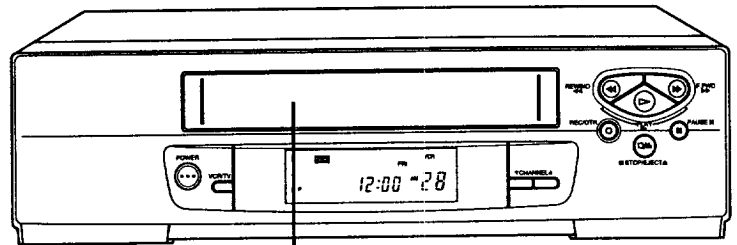

2

VCR

Play, fast forward, or rewind a tape to the point that you would like to refer to later.

5

When in Stop mode, press the REW(ind)/SEARCH or FF/SEARCH button to return to the previous or next place the time counter was reset to zero.

1

Press the STATUS button to bring up the Time Counter display.

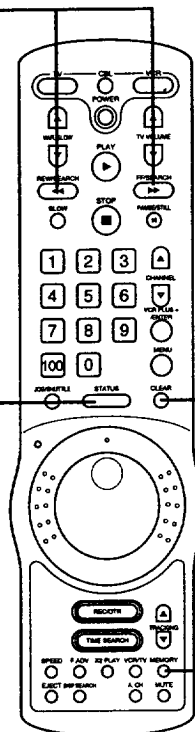

3

Press the CLEAR button to reset the time counter to zero.

4

Press the MEMORY button to memorize the tape location.

Remote Control

Playback Options (cont'd)

Forward and Reverse Searching (SP/LP/SLP mode):

- 1** When in play mode, press and release the FF/SEARCH or REW(ind)/SEARCH button. A fast forward or reverse picture search will begin.
- 2** To return to playback, press the PLAY button.

Super High Speed Searching (LP/SLP mode)

- 1** When in play mode, press the FF/SEARCH or REW(ind)/SEARCH button, then press again. The unit will now search in super high speed.
- 2** To return to normal playback, press the PLAY button.

Playing a Tape at Double Speed

- 1** When in Play mode, press the X2 PLAY button. The picture will run at twice normal playback speed.
- 2** To return to normal playback, press the X2 PLAY or the PLAY button.

Viewing a Still Picture

- 1** When in Play mode, press the PAUSE/STILL button. A still picture (frozen image) will appear on-screen.
- 2** To advance the still picture frame-by-frame, press the F(rame) ADV(ance) button.
- 3** To release the still picture and return to normal playback, press the PLAY or PAUSE/STILL button.

Viewing a Slow Motion Picture

- 1** When in Play mode, press the SLOW button. The tape will play in slow motion.
NOTE: You can control the speed of slow motion playback by pressing the VAR(iable) SLOW buttons.
- 2** To release Slow mode and return to normal playback, press the SLOW or the PLAY button.

Viewing a Picture in Slow to Fast Motion

- 1** Press the JOG/SHUTTLE button while in the Play or Still mode. The Jog/Shuttle Light comes on. If you do not operate the Jog Dial or Shuttle Ring for a period of 30 seconds, the Jog/Shuttle light will go off.
- 2** Turn the outer ring in either direction. The farther the ring is rotated, the faster the search speed. Releasing the ring stops the picture in the Still mode.
- 3** Turn the inner dial in either direction for jog (frame-by-frame) control. The farther the dial is rotated, the faster the speed in either the forward or reverse direction. Releasing the dial stops the picture in the Still mode.
- 4** Press the PLAY button to release the Still mode.

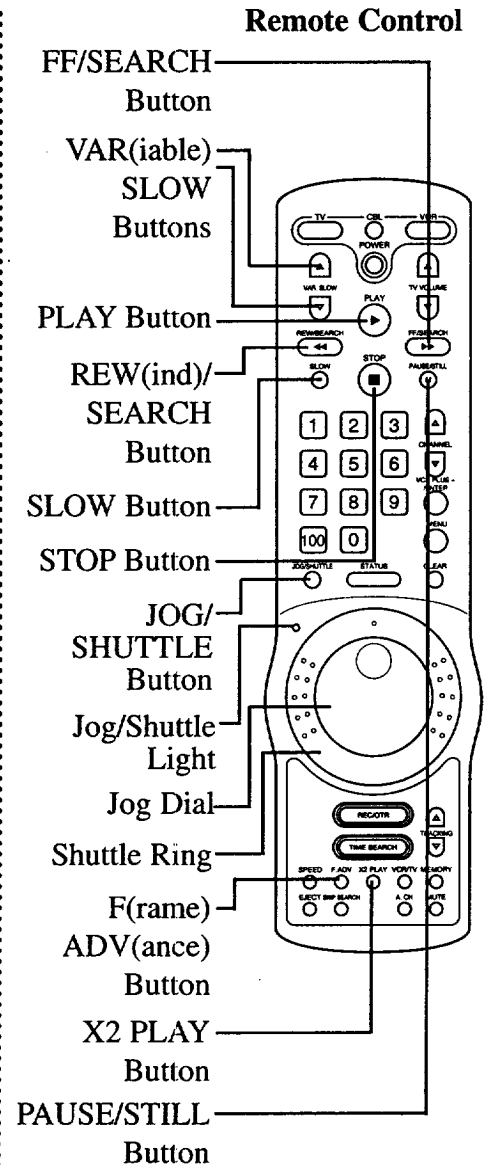

- Still and Slow modes automatically switch to Stop mode after five minutes to protect the VCR and the tape from damage.
- SP/LP/SLP mode means this feature will work with tapes recorded in Standard Play speed, Long Play speed, or Super Long Play speed. For details on tape speed, see page five.
- LP/SLP mode means this feature will work tapes recorded in Long Play speed and Super Long Play speed. For details on tape speed, see page five.
- If a still picture vibrates vertically, stabilize it by pressing the TRACKING buttons (any other vertical jitter should be removed with your TV's vertical hold control, if your TV has one).

Playback Features

Remote Control

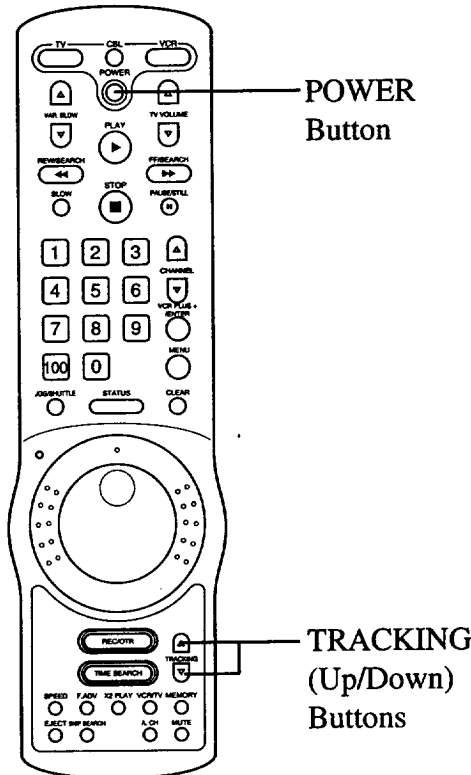

The following playback features will always operate:

Automatic Playback

When you put a tape in the VCR, the power will come on automatically. If the tape's record tab is missing, playback will begin.

Automatic Rewind, Eject Off

When a tape is played, fast forwarded, or recorded to its end, the VCR will rewind the tape, enter Stop mode, and eject the tape. Then the VCR will turn itself off.

Memory Rewind, Power Off

When the POWER button is pressed while the VCR is rewinding a tape, the VCR will turn itself off when it has finished rewinding. REWIND → POWER OFF will appear on-screen.

Tape Eject

A tape can be ejected with the VCR power on or off (but the VCR must be plugged in). A tape cannot be ejected when a timer recording is programmed.

Auto Tracking

The VCR has automatic tracking, which continually adjusts tracking to give you the best possible picture quality. With some recordings, however, you may get a better picture using the manual tracking controls (see below).

Manual Tracking

To adjust the tracking manually, press the TRACKING (Up/Down) buttons on the remote control.

NOTES:

- To return tracking to the position it was in when the VCR was shipped from the factory, press at the same time the CHANNEL (Up/Down) buttons on the VCR.
- Tracking is returned to auto tracking when a tape is inserted, or when the STOP button is pressed to halt playback.
- The CHANNEL (Up/Down) buttons also adjust tracking when the VCR is in Play mode.
- When the VCR is in Slow mode, auto tracking will not work. Instead, use the TRACKING (Up/Down) buttons to reduce noise lines in slow motion playback.
- Manual tracking will not operate when the VCR is in Still mode. If you want to reduce noise lines in a still picture, place the unit in Slow mode. Use the TRACKING (Up/Down) buttons to remove the noise lines. Then return to Still mode.

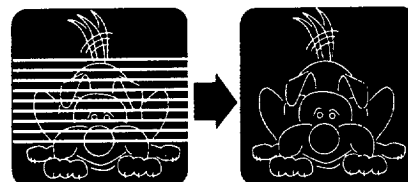

TV Code Setting

Your VCR remote control may be able to operate your TV. If the remote control doesn't operate your TV now, find your brand of TV on the list at right, and follow the steps below to program your remote control accordingly.

1

Point the remote control at your TV and press the TV button. Then, press the POWER button. If your TV comes on, try the other TV buttons (see pages 12 - 13 for details). If your TV doesn't come on, or if the other buttons don't work, go to step 2.

2

Find the brand of your TV on the list below, and remember the number to the right of it.

3

Press and release the MUTE button.

4

Within thirty seconds after releasing the MUTE button, press and release the TV button.

5

Within thirty seconds after releasing the TV button, press the Number buttons to enter the code for your TV brand. For example, if you have a Zenith TV, press Number buttons 0, 5.

6

Try step 1 again. If the remote control works your TV, you're finished. If the remote control still doesn't work your TV, repeat steps 2 - 5, using another code.

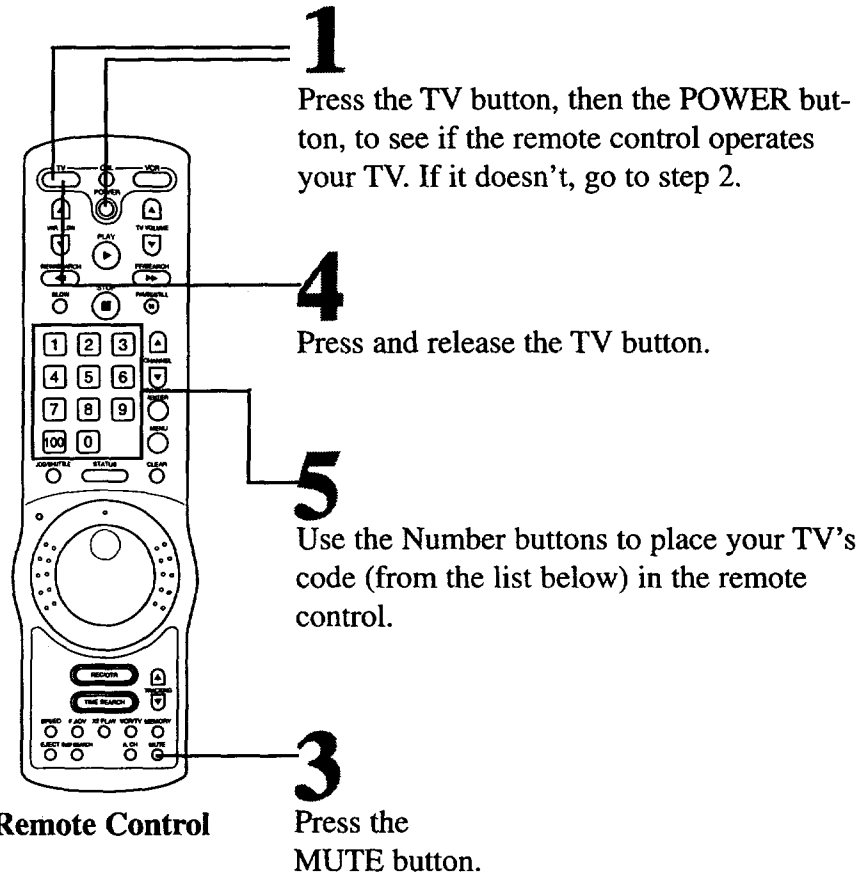

2

Find the brand of your TV on this list.

There is no guarantee that the remote control will work your TV.

- Although the remote control that comes with your VCR will work most Magnavox TVs, as well as many TVs sold under other brand names, it is possible that the remote control will not operate your TV.
- If you had to program the remote control to operate your TV here, whenever you replace the batteries in the remote control, you will have to program the remote control again.

Cable Converter Box Code Setting

Your VCR remote control **may** be able to operate your cable converter box. If the remote control doesn't operate your cable converter box now, find your brand of cable converter box on the list at right, and follow the steps below to program your remote control accordingly.

1

Point the remote control at your cable converter box and press the CBL button. Then, press the POWER button. If your cable converter box comes on, try the other cable converter box buttons (see pages 12 - 13 for details). If your cable converter box doesn't come on, or if the other buttons don't work, go to step 2.

2

Find the brand of your cable converter box on the list below, and remember the number to the right of it.

3

Press and release the MUTE button.

4

Within thirty seconds after releasing the MUTE button, press and release the CBL button.

5

Within thirty seconds after releasing the CBL button, press the Number buttons to enter the code for your cable converter box brand. For example, if you have a Zenith cable converter box, press Number buttons 1, 3.

6

Try step 1 again. If the remote control works your cable converter box, you're finished. If the remote control still doesn't work your cable converter box, repeat steps 2 - 5, using another code.

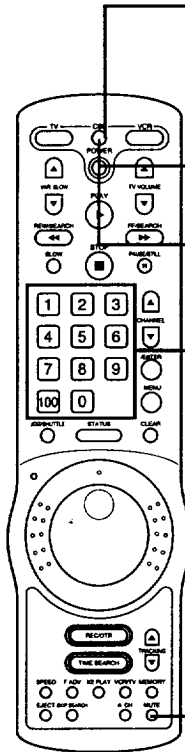

Remote Control

1

Press the CBL button, then the POWER button, to see if the remote control operates your cable converter box. If it doesn't, go to step 2.

4

Press and release the CBL button.

5

Use the Number buttons to place your cable converter box's code (from the list below) in the remote control.

3

Press the MUTE button.

6

Try step 1 again. If the remote control works your cable converter box, you're finished. If the remote control still doesn't work your cable converter box, repeat steps 2 - 5 using another code.

2

Find the brand of your cable converter box on this list.

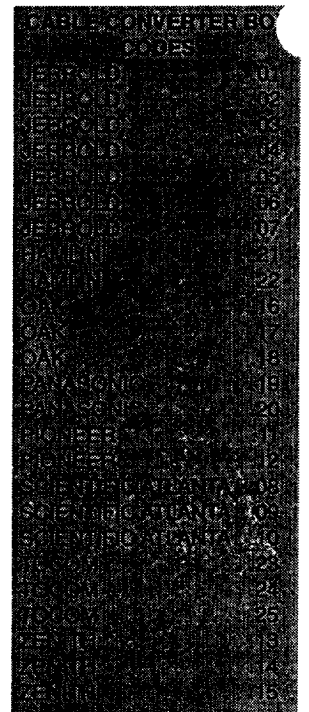

There is no guarantee that the remote control will work your cable converter box.

- Although the remote control that comes with your VCR will work most Magnavox cable converter boxes, as well as many cable converter boxes sold under other brand names, it is possible that the remote control will not operate your cable converter box.
- If you had to program the remote control to operate your cable converter box here, whenever you replace the batteries in the remote control, you will have to program the remote control again.

Hooking Up Your VCR

If the reception on all channels is poor, you may need to tune your TV set again.

Timer Recording

- If the power fails for more than one minute, programmed timer recordings may be lost.
- It is best to finish programming a timer recording at least five minutes before the recording is scheduled to begin.
- If, after programming a timer recording, you turn the VCR power off without putting a tape in the VCR, the Timer light will blink.
- If the record tab on a tape is missing, the VCR will eject the tape. The Timer light will blink.
- 12 PM is noon; 12 AM is midnight.

Power Failure

Timer recordings and the time may be lost if the power fails for more than one minute.

Satellite Hookups

- Watching one TV channel while recording another may not be possible if you have a satellite hookup.
- You may have to set your TV to channel 3 or 4, then make your channel selections at the satellite converter box.
- With many satellite hookups, if you use accessory audio and video cables to connect your VCR to your TV, you will have to program your VCR to accept line input. To enter Line Input mode, press 0, 0. A/V IN will appear on your TV screen briefly.

Line Input

If you accidentally enter Line Input mode (A/V IN will appear on your TV screen briefly), press the CHANNEL (Up/Down) buttons or use the Number buttons to select another channel.

Daylight-Saving Time

When automatic daylight saving time is set, the clock time will change automatically as follows: on the first Sunday in April, 2:00 AM to 3:00 AM; on the last Sunday in October, 2:00 AM to 1:00 AM.

- During the April time change, a timer recording programmed to start between 2:00 AM and 2:59 AM will not record. A timer recording programmed to end between 2:00 AM and 2:59 AM will end when the clock moves forward (2:00 AM).
- During the October time change, a recording cannot be started between the second 1:00 AM and 1:59 AM.

Other Hookups

Antenna/Cable to VCR to TV Hookups

1 Disconnect the antenna or cable from your TV (to avoid confusion, label all cable ends and jacks on the TV before disconnecting anything).

2 Connect the antenna or cable to your VCR.

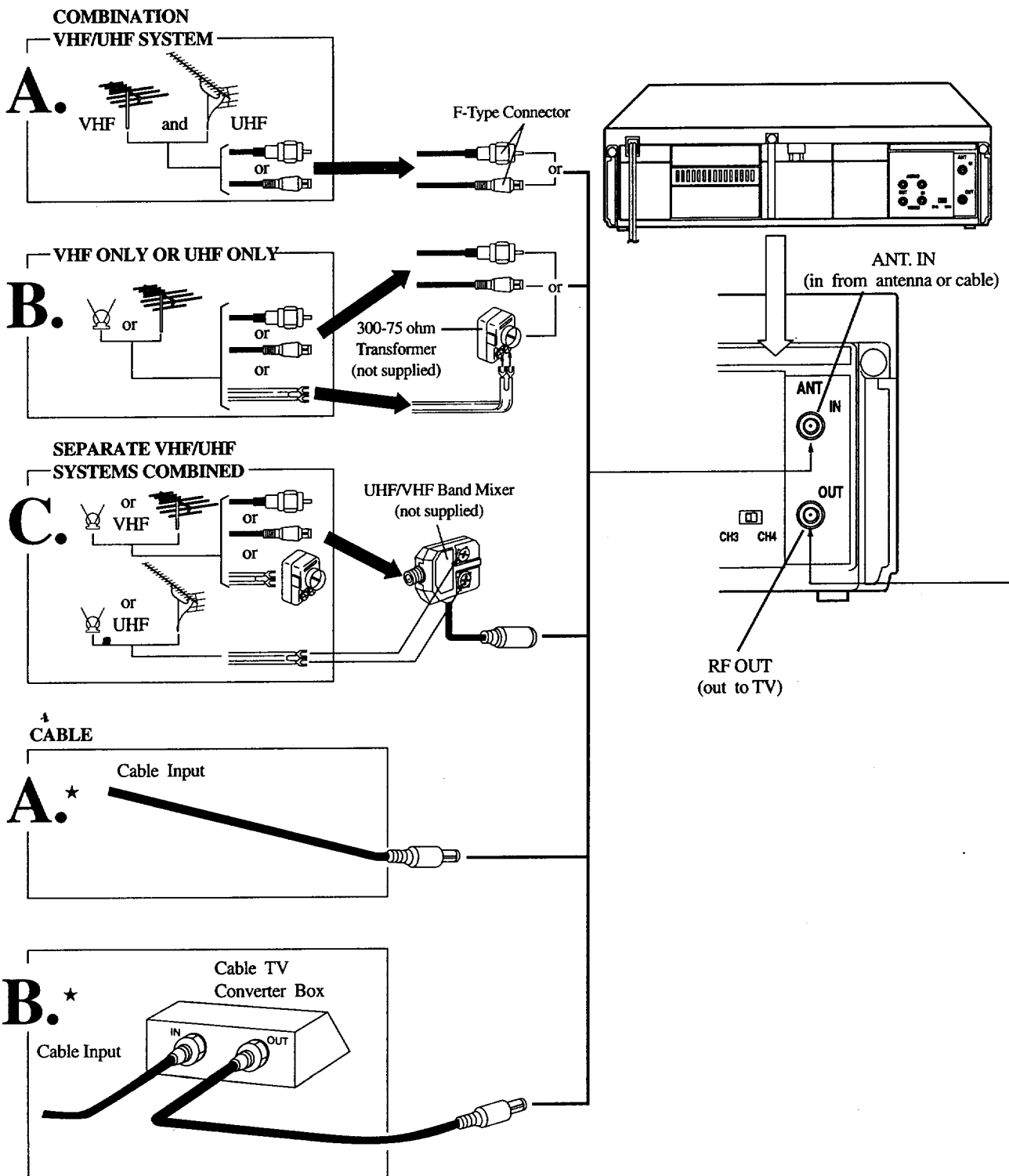

Other Hookups (cont'd)

3 Connect your VCR to your TV, using only one of the connections shown below.

4 Select channel 3 or 4 at the back of the VCR.

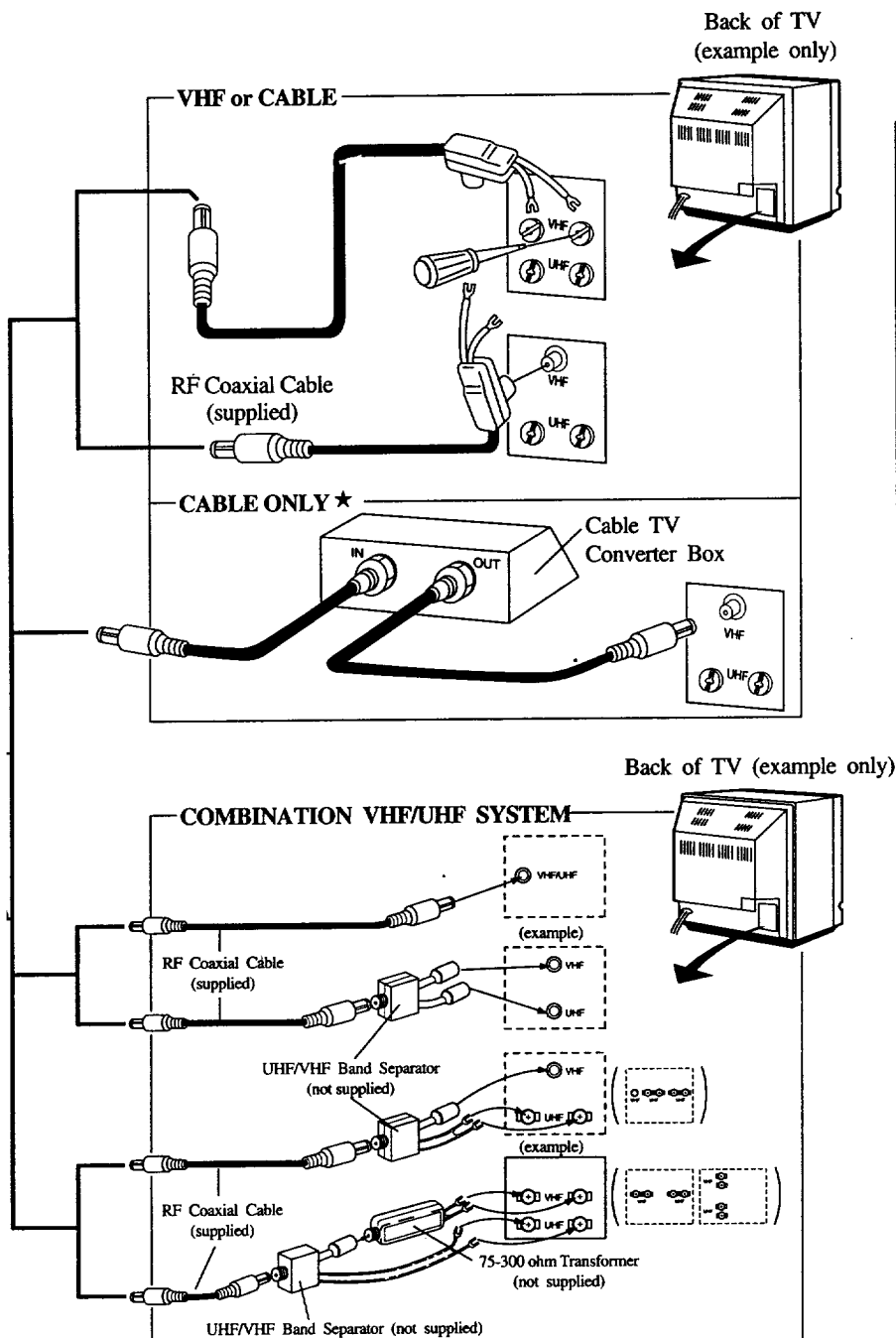

If you have a UHF-only antenna system: Even if you only plan to play tapes and view/record UHF channels, you still need to make one of the combination UHF/VHF connections shown above. This is because when your VCR operates, it sends VHF signals to the TV across the RF coaxial cable.

★ Please see pages 38-39 for details.

Other Hookups (cont'd)

With a Converter/Descrambler Box

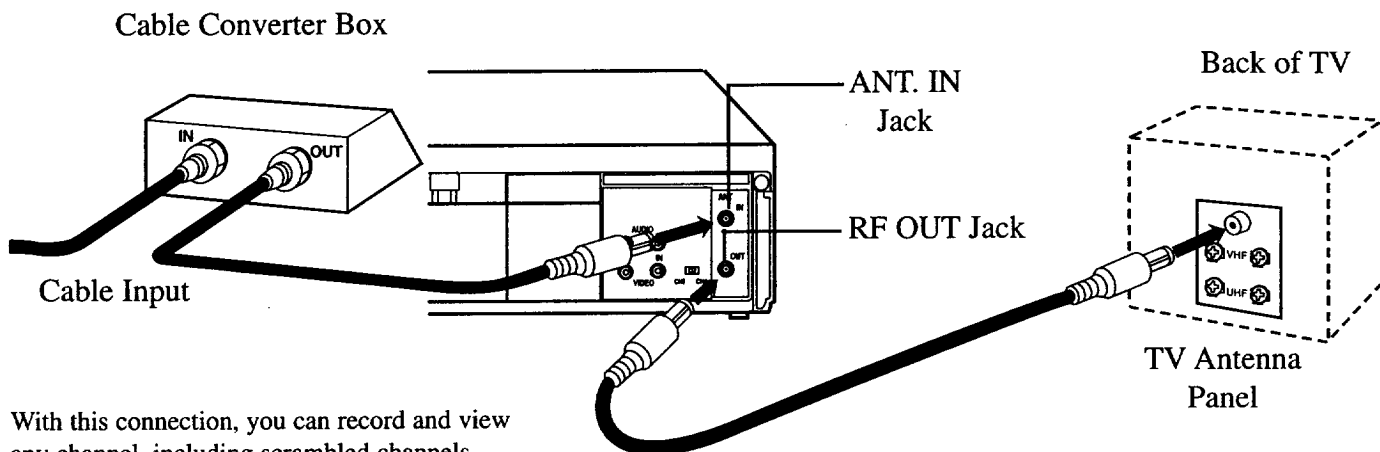

With this connection, you can record and view any channel, including scrambled channels. However, channel selections must be made at the cable converter box. This means that:

- You can record any channel by using the your remote control to select channels on the cable converter box (see "Cable Converter Box Code Setting" on page 34).
- Timer recordings are programmed differently than shown on pages 20 - 25.
 - You can only program a timer recording for one channel at a time.
 - When you are prompted to enter the channel you want to record, select channel 3 or 4 (whichever is the output channel of your cable converter box).
 - Set your cable converter box to the channel you want to record.
 - Leave the cable converter box on while you are recording.
- You cannot view a channel other than the one you are recording (the instructions on page 17 do not work with this hookup).
- You cannot program channels with this hookup (as discussed on pages 7 and 26).

Recording and Viewing a Scrambled or Unscrambled Channel

1

With the VCR on and in VCR position, use the CHANNEL (Up/Down) buttons to set the VCR to the output channel of the cable converter box (channel 3 or 4).

2

Set the TV to the same channel to which you set the VCR.

3

Select the channel you want to record at the cable converter box.

Watching TV With the VCR Off

1

Use the TV channel selector to set the TV to the same channel as the output channel of the cable converter box .

2

Use the cable converter box channel selector to select the channel you want to watch.

- To program a timer recording with this hookup, see "Timer recordings are programmed..." above left.
- The cable converter box must be on during recording.

Other Hookups (cont'd)

With a (VCR to TV) Converter/Descrambler Box

This is an alternative to the connection shown on page 38. It allows you to program an unattended recording of more than one unscrambled channel and watch one channel while recording another.

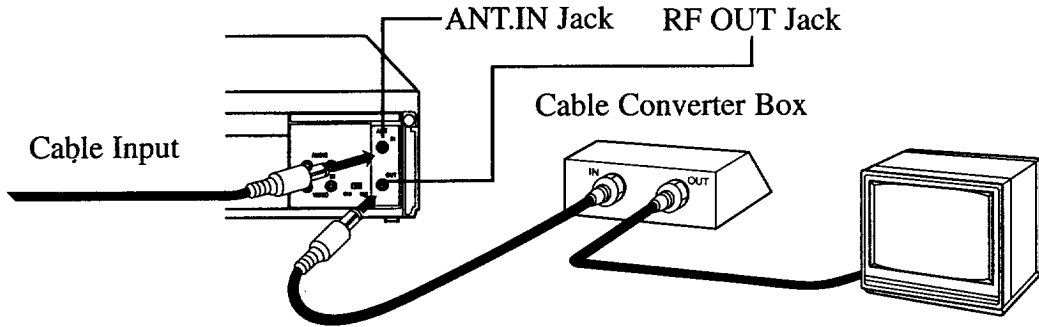

Recording One Channel/ Watching Another

1

With the VCR in VCR position, use the CHANNEL (Up/Down) buttons to select the channel you want to record.

2

Use the TV/VCR button to put the VCR in TV position.

3

Use the TV channel selector to put the TV on the same channel as the output channel of the cable converter box.

4

Select the channel you want to watch at the cable converter box.

Playing a Tape

1

Use the TV/VCR button to put the VCR in VCR position.

2

Use the TV channel selector to put the TV on the same channel as the output channel of the cable converter box.

3

Put the cable converter box on the same channel as the VCR CH3/CH4 switch.

- Use the CHANNEL (Up/Down) buttons to select the channel being recorded, even when programming a timer recording or a one touch recording.
- You cannot record scrambled channels with this connection.

VCR to Stereo TV Hookups

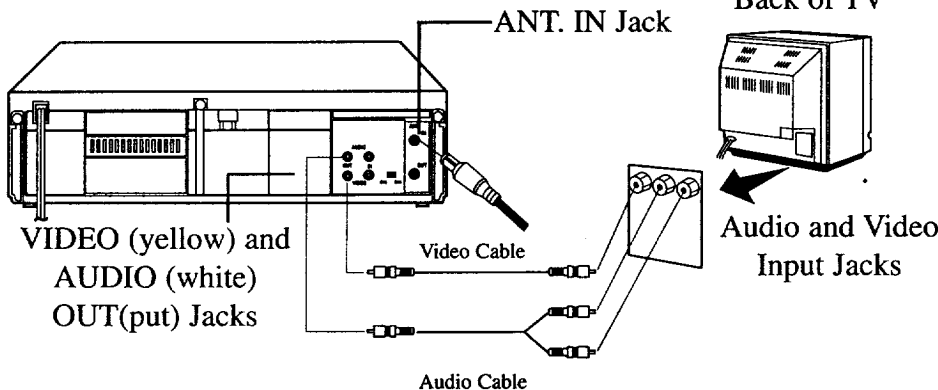

- A Y splitter audio cable (not supplied) is used here to deliver audio to the TV's left and right channels.
- Cables are not supplied.
- The TV must be set to accept line input. Please refer to your TV owner's manual.
- This hookup will not give you stereo sound. To get stereo sound, use the connections on page six and select channel to be viewed at the TV (with the VCR turned off).

Before Requesting Service

If you are having problems with your VCR, check the following list of problems and possible solutions before requesting service. You may be able to solve the problem yourself.

Power

No power

- Make sure the power plug is completely connected to an AC (alternating current) outlet.
- Make sure the power is turned on.

Power failure

- Follow the steps on page seven to select a language and program channels, if prompted to do so. Then follow the steps on page 10 to reset the clock.

Recording/Playback

TV program cannot be recorded

- Check the connections between the VCR, TV, and the antenna/cable (page six).
- Make sure the band selected (VHF/UHF) matches your antenna/cable system.
- Make sure the tape has a record tab (page five).

VCR will not perform a timer recording

- Make sure the recording start and stop times are set correctly (pages 20 - 25).
- Make sure the VCR power is off.
- Make sure the clock is set (page 10).
- The VCR may not perform or continue a timer recording if a power interruption of more than one minute occurs during the timer recording, even if the power comes back on afterward.

There is no playback picture, or the playback picture is noisy or contains streaks

- Make sure the TV is on the same channel as the VCR's CH3/CH4 switch (page six).
- Make sure the VCR is in VCR position (pages 13 - 16).
- Make sure channel 3 or 4 is properly adjusted.
- Adjust the tracking (page 32).

During special effects playback, the picture is noisy or contains vertical jitter when using a TV with an automatic vertical hold control

- Set the TV's vertical hold control to manual, then adjust (page 31).

The top of the playback pictures waves back and forth excessively

- Because the VCR playback signal is not as stable as an off-the-air TV signal, the top of the TV screen may waver during playback. To stop this, slowly turn the horizontal hold control on the TV. If the TV does not have a horizontal hold control, or if adjusting the control does not help, contact your TV service center.

Remote Control

VCR cannot be controlled with remote control

- Press VCR button on the remote control, then try again.
- Aim the remote control directly at the VCR's remote sensor (page five).
- Remove all obstacles between the remote control and the VCR (page five).
- Inspect and/or replace the batteries in the remote control (page five).

Number buttons won't work for channels above 69

- Select CABLE TV from the tuner setup display, then auto program channels (page 26).

(continued on page 41)

Periodic maintenance is required to maintain your VCR's continued excellent performance. Your VCR has an automatic head cleaning system that helps prevent clogging of the video heads. Cleaning is performed each time you insert or remove a video cassette. However, this feature is preventative only. If the video heads are very clogged, take your VCR to an authorized service center.

(continued from page 40)

Miscellaneous

TV programs cannot be watched normally

Tape cannot be inserted

Tape cannot be removed

VCR ejects tape when the REC(ord)/OTR button is pressed or when the VCR power is turned off to set the timer

The motor (cylinder) rotates even when the VCR is in Stop mode

Channels above 13 cannot be received

- Put the VCR in TV position (pages 13 - 16).
- Check the connections between the VCR, TV, and the antenna/cable (page six).
- Insert the tape window side up, with the record tab facing you.
- Make sure a tape isn't already in the VCR by pressing the STOP/EJECT button on the VCR or the EJECT button on the remote control.
- Make sure the power plug is completely connected to an AC (alternating current) outlet.
- Make sure the tape has a record tab (page five).
- To enable the quick play mechanism, the cylinder will rotate for about five seconds. This is normal.
- Select CABLE TV from the tuner setup display, then auto program channels (page 26).

Glossary

AUDIO IN(put)/OUT(put) Jacks: jacks located on the back of the VCR which are used to record audio from another source (input) or send audio to another source (output).

Auto Programming: process in which the VCR scans all available channels and places the ones you receive in its memory. Then, when you push the CHANNEL (Up/Down) buttons, you only scan through channels you receive.

Bands: settings that allow you to tune channels.

- **Antenna** – VHF (very high frequency; channels 2 - 13) and UHF (ultra high frequency; channels 14 - 69).
- **Cable** – all standard channels can be received without a cable converter box.

Dubbing: copying a tape using a second VCR.

Frame: a single still picture.

HQ: high quality; a feature in the VCR circuitry which provides enhanced picture detail.

Matching Transformer: an adapter, used primarily on non-cable TVs, which has a "screw on" connector on one end and two flat prongs on the other end.

Mode: a VCR operation.

OTR: one touch recording; programming a timed recording that starts immediately and records for 30 minutes to four hours, whatever you specify.

Remote Control: the small electronic unit that came with your VCR; allows you to operate your VCR from a distance.

Special Effects: forward and reverse searching, viewing a still picture, and slow motion playback.

Separator: an adapter used to separate VHF and UHF signals when connecting the TV to the VCR.

Tape Speeds: how fast the tape travels during a recording.

- **SP** (standard play) – fastest tape speed (recording time for a T120 tape is approximately two hours); best picture quality.
- **LP** (long play) – average tape speed (recording time for a T120 tape is approximately four hours); available for playback only.
- **SLP** (super long play) – slowest tape speed (recording time for a T120 tape is approximately six hours).

VCR: video cassette recorder.

VIDEO IN(put)/OUT(put) Jacks: jacks located on the back of the VCR which are used to record video from another source (input) or send video to another source (output).

LIMITED WARRANTY

VIDEO CASSETTE RECORDER

90 Days Free Labor

One Year Free Service on Parts

This product must be carried in for repair.

WHO IS COVERED?

You must have proof of purchase to receive warranty service. A sales receipt or other document showing that you purchased the product is considered proof of purchase.

WHAT IS COVERED?

Warranty coverage begins the day you buy your product. *For 90 days thereafter*, all parts will be repaired or replaced, and labor is free. *From 90 days to one year from the day of purchase*, all parts will be repaired or replaced, but you pay for all labor charges. *After one year from the day of purchase*, you pay for the replacement or repair of all parts, and for all labor charges.

All parts, including repaired and replaced parts, are covered only for the original warranty period. When the warranty on the product expires, the warranty on all replaced and repaired parts also expires.

WHAT IS EXCLUDED?

Your warranty does not cover:

- labor charges for installation or setup of the product, adjustment of customer controls on the product, and installation or repair of antenna systems outside of the product.
- product repair and/or part replacement because of misuse, accident, unauthorized repair or other cause not within the control of Philips Consumer Electronics Company.
- reception problems caused by signal conditions or cable or antenna systems outside the unit.
- a product that requires modification or adaptation to enable it to operate in any country other than the country for which it was designed, manufactured, approved and/or authorized, or repair of products damaged by these modifications.
- incidental or consequential damages resulting from the product. (Some states do not allow the exclusion of incidental or consequential damages, so the above exclusion may not apply to you. This includes, but is not limited to, prerecorded material, whether copyrighted or not copyrighted.)
- damage caused by the use of non-VHS tapes or tapes that have not been tested and labeled for use in two, four, six and eight hour VHS recorders.
- a product that is used for commercial or institutional purposes (including but not limited to rental purposes).

WHERE IS SERVICE AVAILABLE?

Warranty service is available in all countries where the product is officially distributed by Philips Consumer Electronics Company. In countries where Philips Consumer Electronics Company does not distribute the product, the local Philips service organization will attempt to provide service (although there may be a delay if the appropriate spare parts and technical manual(s) are not readily available).

MAKE SURE YOU KEEP...

Please keep your sales receipt or other document showing proof of purchase. Attach it to this owner's manual and keep both nearby. Also keep the original box and packing material in case you need to return your product.

BEFORE REQUESTING SERVICE...

Please check your owner's manual before requesting service. Adjustments of the controls discussed there may save you a service call.

TO GET WARRANTY SERVICE IN U.S.A., PUERTO RICO OR U.S. VIRGIN ISLANDS...

Take the product to a Philips factory service center (see enclosed list) or authorized service center for repair. When the product has been repaired, you must pick up the unit at the center. Centers may keep defective parts.

(In U.S.A., Puerto Rico and U.S. Virgin Islands, all implied warranties, including implied warranties of merchantability and fitness for a particular purpose, are limited in duration to the duration of this express warranty. But, because some states do not allow limitations on how long an implied warranty may last, this limitation may not apply to you.)

TO GET WARRANTY SERVICE IN CANADA...

Take the product to a Philips consumer service center (listed below), self-servicing dealer or authorized service depot.

Philips Electronics Ltd.

601 Milner Avenue, Scarborough, Ontario, M1B 1M8

(416) 292-5161

5930 Côte de Liesse, Montréal, Québec, H4T 1E1

(514) 342-9180

3695 Grandview Highway, Vancouver, B.C., V5M 2G7

(604) 435-4411

(In Canada, this warranty is given in lieu of all other warranties. No other warranties are expressed or implied, including any implied warranties of merchantability or fitness for a particular purpose. Philips is not liable under any circumstances for any direct, indirect, special, incidental or consequential damages, howsoever incurred, even if notified of the possibility of such damages.)

REMEMBER...

Please record the model and serial numbers found on the product below. Also, please fill out and mail your warranty registration card promptly. It will be easier for us to notify you if necessary.

MODEL # _____

SERIAL # _____

-
- a ch13
 - ac power cord16
 - accessories44
 - antenna input jack16
 - audio input/output jacks16
 - automatic
 - playback32
 - rewind32
 - batteries5
 - cable converter box controls12-13
 - cassette-inside light14
 - cassette (also see *tape*)
 - compartment14
 - cbl button12
 - ch3/ch4 switch6, 16
 - channel
 - /line input display14
 - above 1005
 - adding27
 - deleting27
 - memory26
 - programming26
 - reviewing27
 - up/down buttons13, 15
 - clear button13
 - connections6, 19, 36-39
 - contents, table of4
 - controls
 - remote12-13
 - vcr14-16
 - clock10
 - clock/counter/channel display14
 - counter only mode11
 - day display14
 - daylight-saving time28
 - digital tracking light14
 - display panel14
 - duplication19
 - eject button12
 - erase protection5
 - f. adv button12
 - feature light14
 - ff/search button12, 15
 - front panel15
 - glossary41
 - hookups
 - basic6
 - notes35
 - other36-39
 - jog & shuttle
 - button12
 - light12
 - jog dial12
 - language selection7, 28
 - line input
 - mode19
 - mode light14
 - long play5
 - lp5
 - memory
 - button13
 - light14
 - rewind, power off32
 - menu button13
 - mute button13
 - notes35
 - number buttons12
 - on-screen
 - displays11
 - on mode11
 - off mode11
 - one touch recording18
 - otr button12, 18
 - pause/still button13
 - playback
 - features32
 - options29-31
 - play button13, 15
 - playing8
 - power
 - button13, 15
 - cord16
 - rear panel16
 - rec/otr button13, 15
 - record light14
 - recording
 - basic9
 - one channel/watching another17
 - timer20-21
 - vcr plus+25
 - remote control
 - buttons12, 13
 - using5
 - sensor5
 - repeat
 - light14
 - playback29
 - requesting service40
 - rerecording19
 - rewind/search button12, 15
 - rf coaxial cable6, 37
 - rf output jack16
 - safety precautions3
 - satellite hookups35
 - search buttons12, 13
 - searching31
 - sensor (remote)5
 - shuttle ring12
 - skip search button13
 - slow
 - button12
 - playback31
 - slp5
 - sp5
 - speed
 - button12
 - light14
 - standard play5
 - status
 - button13
 - display11
 - stereo hookups39
 - still picture31
 - stop button13
 - stop/eject button15
 - super high speed31
 - super long play5
 - tape
 - duplication19
 - eject32
 - speed5
 - table of contents4
 - time
 - (setting)10
 - counter memory30
 - search button12
 - timer
 - light14
 - recording
 - checking20
 - clearing20
 - setting20-21
 - notes35
 - tracking buttons13
 - tv
 - button12
 - controls12
 - hookup6
 - position13
 - volume up/down buttons13
 - var slow buttons31
 - vcr
 - button13
 - light14
 - position12, 15
 - plus+22-25
 - plus+/enter button13
 - status display11
 - vcr/tv button13, 15
 - vertical jitter31
 - video
 - input/output jacks16
 - tapes (see *tape*)
 - warranty42
 - wireless remote sensor5, 15
 - x2
 - button12
 - playback13

Supplied Accessories

Check to be sure the following items are packed with your VCR. These accessories are provided to help you use or set up your VCR.

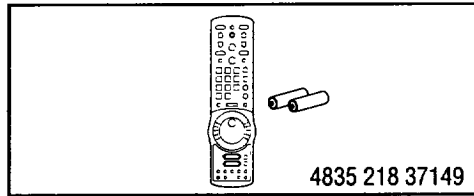

**One-Piece Wireless Remote Control
With 2 AAA Batteries (4835 138 17012)**

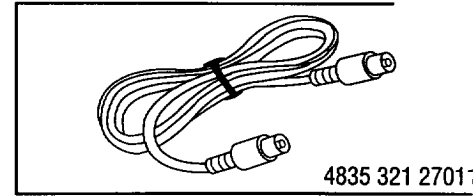

**One-Piece VHF/UHF Connecting Cable,
75 ohm**

Optional Accessories

Prices subject to change without notice. Availability subject to change at time of purchase. When ordering accessories outside the U.S.A., please refer to the accessories material, address, and prices for that country.

Maximize your viewing pleasure
with state-of-the-art accessories
designed specifically for your

VCR. The optional accessories
shown in this booklet may be
purchased from your local
dealer, or may be ordered direct
from Philips Consumer
Electronics Company.

Call toll free:

1-800-292-6066

Or write:

Philips Consumer

Electronics Co.,

Accessories Marketing Dept.,

P.O. Box 967,

Greenville, TN 37744-0967

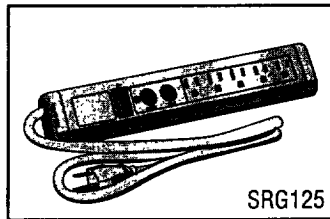

TV/Cable Surge Protector
Your Cost \$19.95

Electrical fluctuations and power surges can damage your valuable electronic entertainment equipment. Protect your antenna, cable, and electrical lines with the Magnavox Audio/Video Equipment Surge Protector.

Features include:

- Coaxial cable input/output
- Five grounded outlets
- Built-in LED and reset button

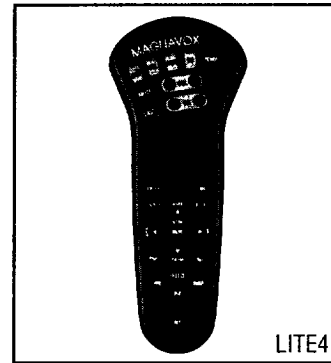

**Universal Night Lite™
Audio/Video Remote**
Your Cost \$24.95

Replace your lost or broken remote control, or consolidate all your remotes into one. Plus, make remote use in dimly-lit areas easier, with our Night Lite™ lighted keypad.

Features include:

- Preprogrammed
- Autoscan and Manual Code Setup
- On-screen capabilities
- Menu programming
- Spanish instructions included
- Toll-free customer assistance number included



VHS Head Cleaner
Your Cost \$4.99

Protect the quality of your VHS VCR or camcorder performance. Proper maintenance, using the VHS Head Cleaner, ensures clearer, sharper pictures and better sound.

Features include:

- Advanced alternating wet/dry system removes dust and dirt without leaving residue
- Easily stores along with other VHS tapes
- Cleaning fluid stores in convenient hideaway door