

Panasonic Omnivision **VHS**

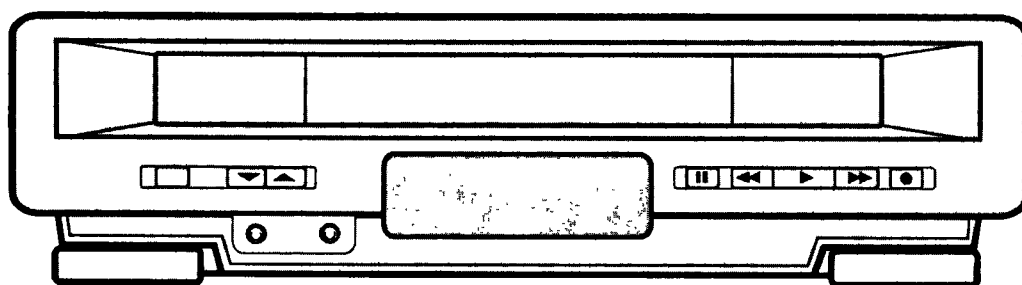

Video Cassette Recorder

MODEL PV-4425S

VCR *Plus⁺*
w/Cable Channel
Changer

Operating Instructions

Before attempting to connect, operate or adjust this product, please read these instructions completely. Spanish Quick Operation Guide is included. Guía para rápida consulta en español está incluido.

Things You Should Know

Congratulations on your purchase of one of the most sophisticated and reliable products on the market today. Used properly, we're sure it will bring you and your family years of enjoyment. Please take time to fill in the information at right. The serial number is on the tag located on the back of your VCR. You'll want to keep this manual handy as your convenient VCR information source.

Date of Purchase _____
Dealer Purchased From _____
Dealer Address _____
Dealer Phone No. _____
Model No. **PV-4425S** _____
Serial No. _____

Unpacking Your VCR

The accessories shown below are provided to help you use or set up your VCR. Optional accessories are also listed.

Accessories

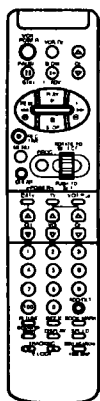

Remote Control
VSQS1340

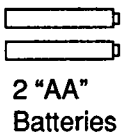

2 "AA"
Batteries



RF Coaxial
Cable
VJAS0155

Optional Accessories

- 1/2" Video Cassette Tape

Load the batteries in the Remote Control

- 1** Press in the direction of the arrow and lift off the lid.

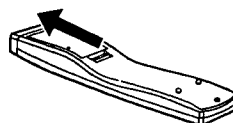

- 2** Install two batteries as indicated inside the Battery Compartment.

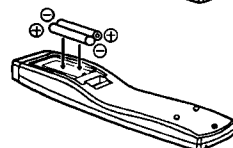

- 3** Replace the lid and snap into place.

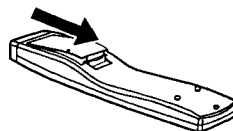

Battery replacement caution

- Do not mix old and new batteries. (Also, never mix alkaline with manganese batteries.)

Safety Precautions

Warning: To prevent fire or shock hazard, do not expose this equipment to rain or moisture.

This video recorder, equipped with the HQ (High Quality) System, is compatible with existing VHS equipment. Only use those tapes with the **VHS** mark. It is recommended that only cassette tapes that have been tested and inspected for use in 2, 4, 6, and 8 hour VCR machines be used.

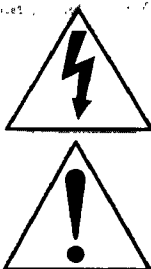

This symbol warns the user that uninsulated voltage within the unit may have sufficient magnitude to cause electric shock. Therefore, it is dangerous to make any kind of contact with any inside part of this unit.

This symbol alerts the user that important literature concerning the operation and maintenance of this unit have been included. Therefore, it should be read carefully in order to avoid any problems.

Control Reference Guide

VCR

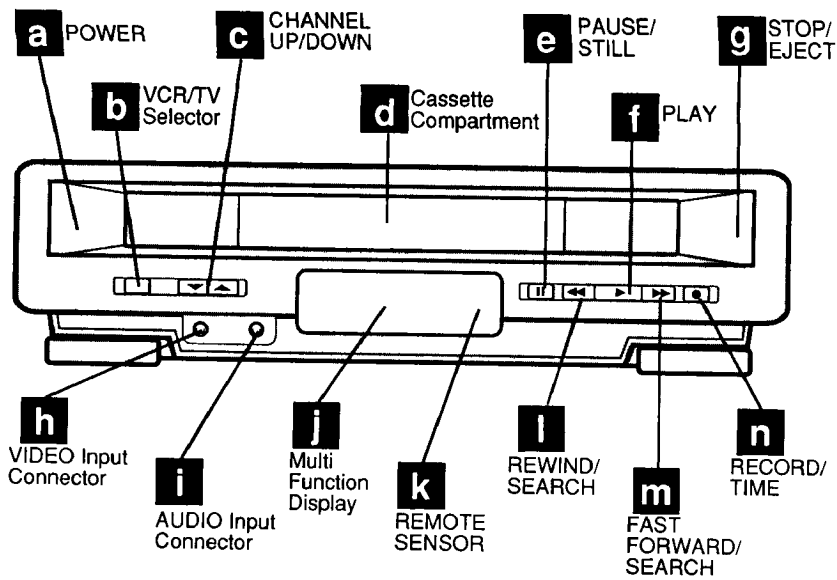

Remote Control

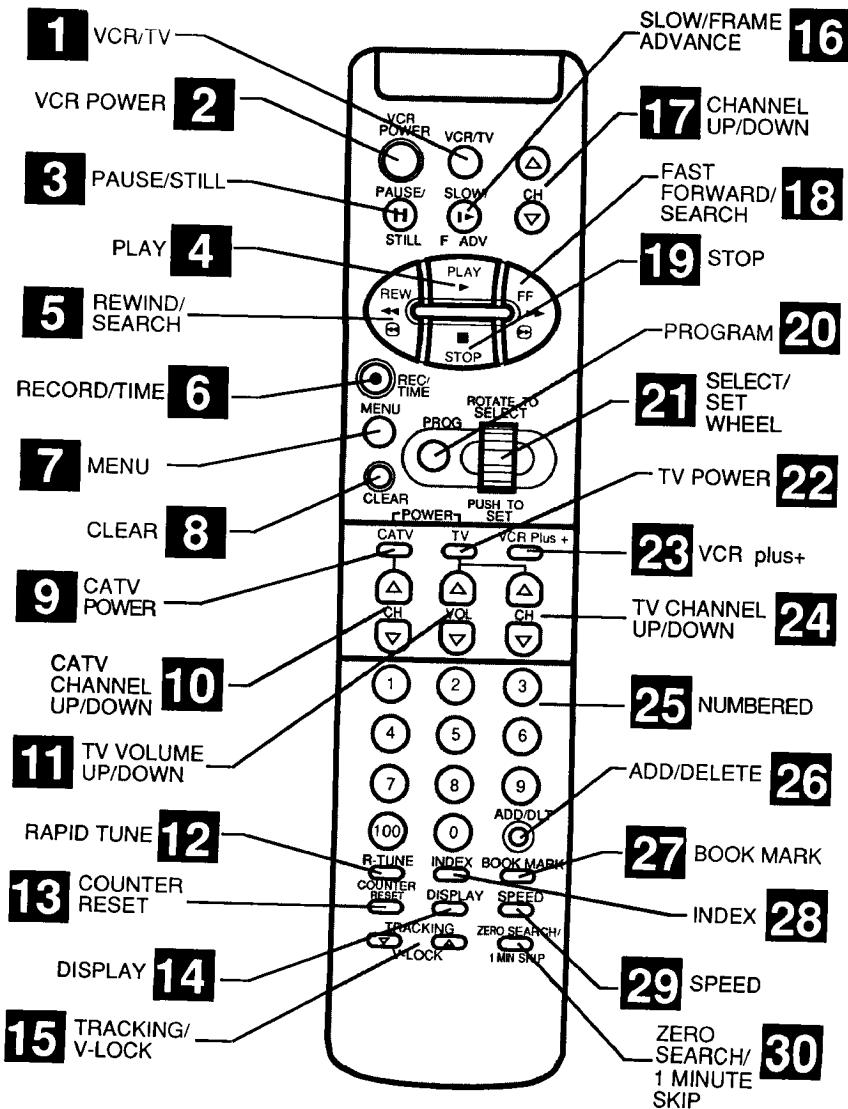

Using this Manual

To get the most from your product, we recommend that you read the Operating Instructions thoroughly and in the order presented. To assist you in locating controls and indicators on the remote control and VCR, we have provided a fold-out Control Reference Guide. Each control and indicator is listed by name as well as a reference number or letter. You will also find corresponding numbers and letters throughout the Operating Instructions. Keep this manual handy as a ready reference source.

- Fold out the Control Reference Guide.

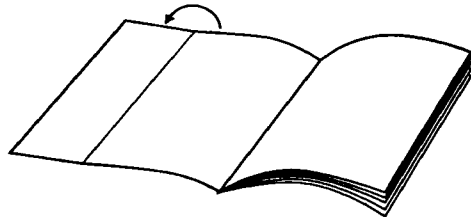

- Read the Operating Instructions carefully.
- When an unfamiliar control or indicator is encountered, see the reference number or letter and then find the corresponding character on the Control Reference Guide.

Example:

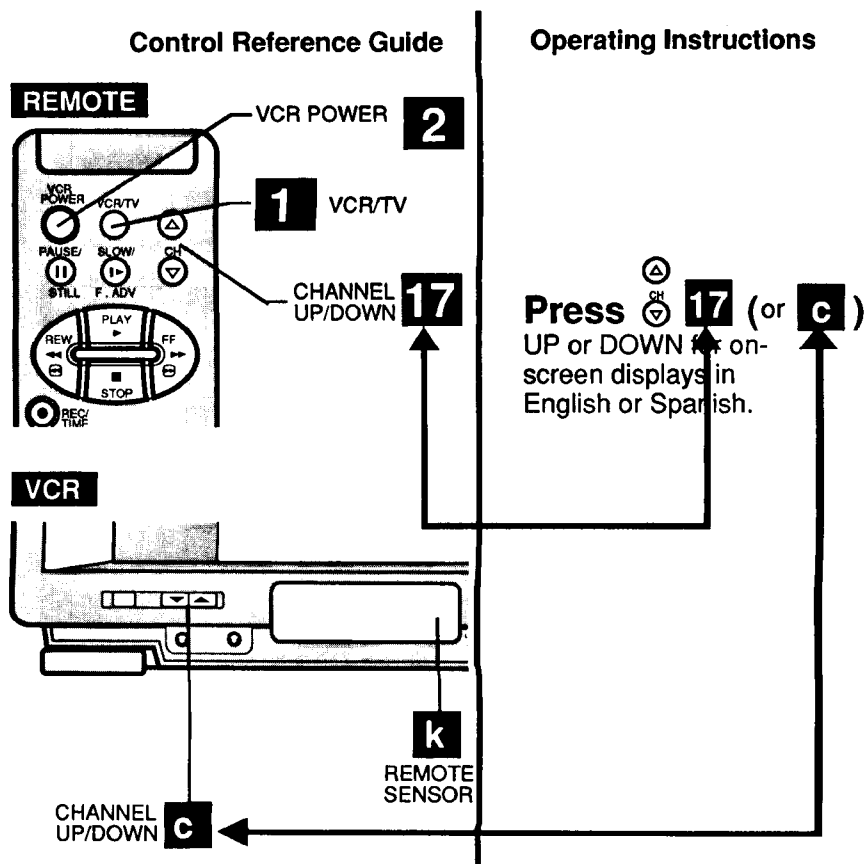

Table of Contents

Connections

See the separate, "Basic Connection Guide" which covers not only TV/VCR connections, but optional Audio/Video and Cable connections as well.

Getting Started

One Time Set Ups (Channel Memory/Setting the Clock)	4, 5
On Screen Displays	6

Basic Operation

Basic Playback/Special Playback	7
Basic Recording	8
Copying Your Tapes	9
Timer Recording	10, 11
VCR Plus+ Set Up	12, 13, 14
VCR Plus+ Programming	15

Other Information

Tape Operation	16, 17
Setting at the VCR	18
Multi-Brand Control Feature	18
Helpful Notes on Operations	19
VCR and Cassette Information	20, 21, 22, 23
Before Requesting Service	24, 25
Spanish Quick Use Guide/Guía para rápida consulta	26, 27
Quick Use Guide	Back cover

Product Features

Auto Daylight Saving Time	19
Auto Operation Functions	16
Auto Repeat Function	16
Book Mark Search	16
Cable Box Channel Control	12, 13
Digital Auto Picture	7
Easy-to-Read English/Spanish On Screen Displays	4, 5, 10, 11
Front-mounted A/V In Terminals	9
Head Cleaner	20
Multi Brand TV/Cable Box Remote Control	18
One Minute Skip	16
One Month, 8 Program Timer Recording	10, 11
One Touch Recording (OTR)	8
Program Director Remote Control	10, 11
Quick Play Mechanism	25
Rapid Tune	5
Special Effects Playback	7
VCR Plus+ Recording	14, 15
VHS Index Search System	17
Zero Search	16
181-CH Cable-Compatible Tuner/All Channel Auto Set	4

One Time Set Ups

When the VCR is first turned on, the language select and channel auto set screens appear automatically followed by a prompter to set the clock.

Before you begin, make sure...

- your Antenna or Cable system is connected to the VCR. (See separate Connection Guide.)
- you familiarize yourself with the easy operation of the Select/Set Wheel before turning on the VCR.

Select/Set Wheel Operation

There are two types of Wheel operation. Selecting from a menu type screen and entering information, such as setting the clock, programming the timer, etc.

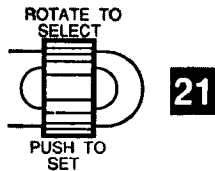

To Use the Wheel

① **Rotate**
(up or down)



to make selection

② **Press**
(like a button)

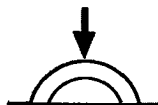

to enter selection

Examples of Operation

A

When selecting from a menu, rotate the Wheel to move the shaded area up or down the screen. Then, press the Wheel like a button to make your selection.

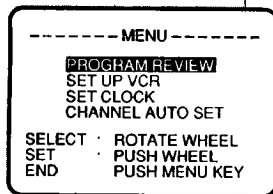

B

When entering information such as setting the clock, rotate the Wheel to change the numbers. Then, press the Wheel to enter and move on to the next item.

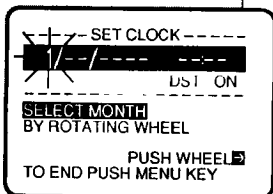

- By repeatedly pressing the Wheel, you can skip over already set items as desired.

- **Select On-Screen Language**
- **Place Channels in Memory**
- **Set the Clock**

1 Press **CH** **17** (or **C**)
UP or Down for on-screen displays in English or Spanish.

- You must choose one.

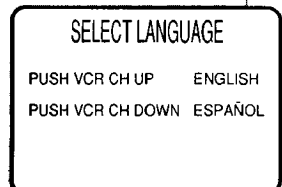

- This screen appears a few seconds later.

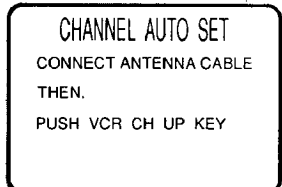

2 Press **17** (or **C**)
to start Channel Auto Set.

- After channels have been placed in memory, the following on-screen displays appear in sequence:
"CH AUTO SET COMPLETED"
The lowest numbered channel.
"PLEASE SET CLOCK BY PUSHING MENU KEY"
- If **MENU** is not pressed within 10 seconds, the VCR will exit this mode. In this case, please see the "Set or Reset the Clock" section on the next page.

3 Press **7**
within 10 seconds to display the SET CLOCK screen.

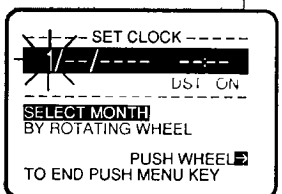

Then, rotate and press

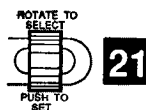

to select and enter the month, date, year, time, and D.S.T. (Daylight Saving Time).

- The day of the week automatically appears.
- "DST:ON" automatically adjusts for Daylight Saving Time. (See page 19 for details.)

Now, press **7**
twice to start the clock and exit this mode.

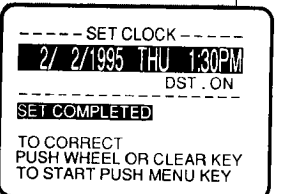

Change the OSD Language

Press  **7** to display the menu.

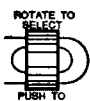
Then, use  **21**

to first, select SET UP VCR from the menu and then to select IDIOMA or LANGUAGE.

- "Idioma" is Spanish for "language."

Now, press  **7** twice to leave this screen.

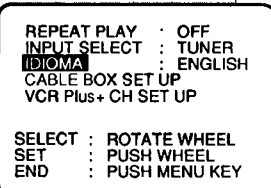
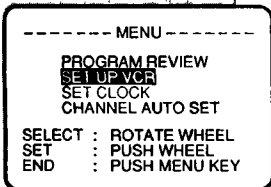

Add or Delete a Channel

Select a channel using the NUMBERED keys on the remote control.

Then, press  **26** to add or delete the channel.

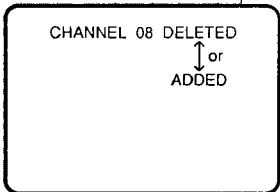

- To select a deleted channel, use the NUMBERED keys on the remote control. Each time a deleted channel is selected, it will flash in the Multi Function Display.

Replace Channels in Memory

Example, if you have cable installed, etc.

Press  **7** to display the menu.

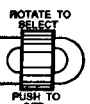
Then, use  **21**

to first, select CHANNEL AUTO SET from the menu and then press to set your antenna system (TV or CATV).

Now, use  **21**

to select AUTO SET and then press to start Auto Set.

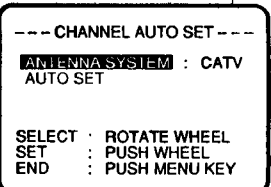
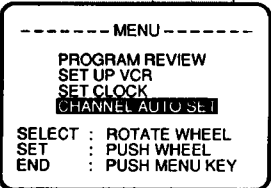

Rapid Tune

Press  **12** to display the last channel you were watching.

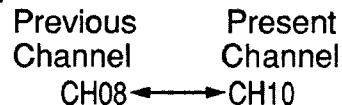

- When selecting channels with the CH UP/DOWN key, the channels must be displayed for at least 4 seconds in order for the VCR to recognize them as a new selection.

Set or Reset the Clock

Press  **7** to display the menu.

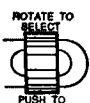
Then, use  **21**

to first, select SET CLOCK from the menu, and then to set the time and date.

Now, press  **7** twice to start the clock and exit this mode.

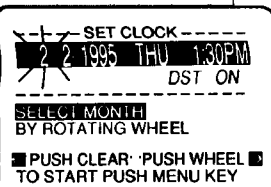
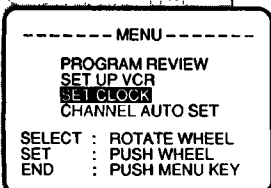

Helpful Notes

- This VCR will accurately maintain its calendar up to Dec. 31, 2012, 11:59PM.
- Make entries within 5 minutes, or the VCR exits the Set Clock screen.
- Normal TV or Cable channels are automatically selected and placed in memory depending on how your VCR is hooked up.
- By pressing the Wheel or CLEAR button repeatedly, you can skip forward or backward over correct entries and go directly to a specific item.

On Screen Displays (OSD)

Function & Channel Display

Whenever a function button is pressed (PLAY, FF, etc.) or the channel is changed, a 4 second OSD will appear first in large and then small characters.

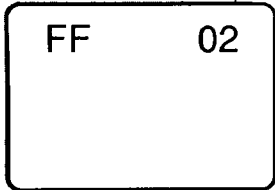

Menu Screen

Press  **7** to display the menu.

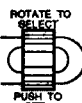
Then, use  **21** to make your selection. (See page 4 for details.)

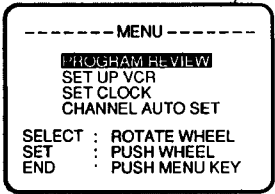

- To get the most from each feature, it is recommended that you read the Operation Manual before attempting any operation.

VCR Status & Clock Display

Press  **14** to display the overlay shown at right.

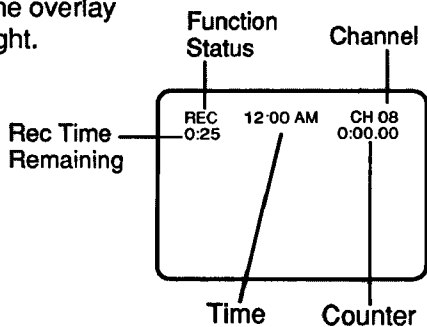

Press again  **14** to leave this mode.

Blank Tape Indication

If a blank section of tape is encountered in the Play mode or the channel you select has no broadcast, the TV screen will change to a solid blue field. The screen will remain blue until a recorded signal is again detected or an active channel is selected.

Warning and Instruction Displays

These displays will alert you to a missed operation or provide further instructions.

If no active channels are found for CHANNEL MEMORY...

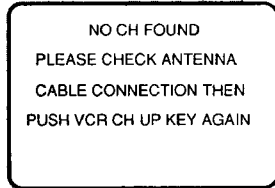

If you attempt to set or review a Timer Recording and the Clock is not set...

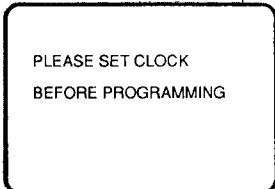

If a Timer Program was not completed before exiting the Program mode...

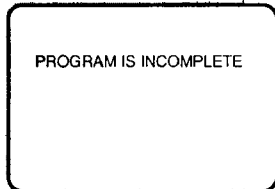

After a Timer Program has been set...

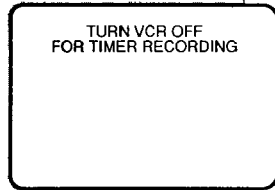

If you press REC on the remote control or REC and PLAY on the VCR, and a cassette is inserted with no record tab...

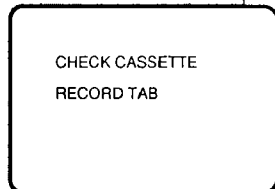

If you press PLAY or REC on the remote control or REC and PLAY on the VCR without a cassette inserted...

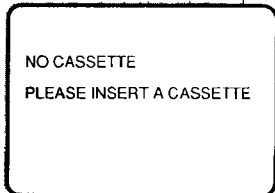

If you press POWER or STOP during a Timer Recording...(visible in VCR mode only)

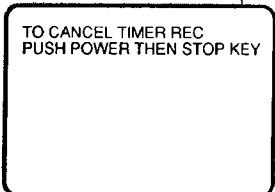

Basic and Special Playback

Before you begin, make sure ...

- connections are made (see separate Connection Guide).
- VCR is plugged in.

Basic Playback Operation

1 Turn TV on. Select VCR Channel (CH3 or CH4).

- The TV channel is the same number you set on the back of the VCR (see separate Connection Guide).

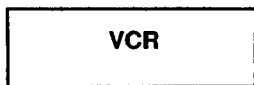

2 Insert a cassette **d**



This indicator lights in the Multi Function Display.

- VCR power comes on automatically. Playback begins if cassette has no record tab.

3 Press  **4** (or **f**) to start playback.

4 Press  **5** (or **l**)
or  **18** (or **m**)
to quickly locate a scene during playback.

- SP mode tapes have a search speed of 9 times and SLP mode tapes 27 times the normal speed.
- Some noise bars will appear during search.

5 Press  **19** (or **g**) to stop playback.

Then, press  **g** on the VCR to eject the cassette.

Special Effects During Playback

These features work best in SP or SLP mode. Sound will be muted.

Slow Motion Playback

Press  **16**

Then, press  **4** (or **f**) to release.

Still Frame Picture

Press  **3** (or **e**)
Press again to release.

Frame Advance

Hold down  **16**

in Still mode to advance the still picture one frame at a time.

Features for a Quality Picture

Digital Auto Picture

This feature automatically controls the video output signal for improved picture resolution or less noise depending on the tape condition.

Digital Auto Tracking

This feature continuously analyzes the signal and adjusts for optimum picture quality.

Manual Tracking Control

Use during Playback and Slow Motion to reduce picture noise.

Press  **15** until the picture clears up.

V-Lock Control

Use during Still mode to reduce jitter.

Press  **15** until the picture is stabilized.

Basic Recording

Before you begin, make sure ...

- connections are made (see separate Connection Guide).
- VCR is plugged in.
- TV is turned on and set to the VCR channel (CH3 or CH4).

Basic Recording Operation

1 Insert a cassette **d** with record tab.

- VCR power comes on automatically.

2 Press  **17** (or **c**) to select a channel to be recorded.

- To record from an outside source, see "Selecting the Input Mode" section on this page.

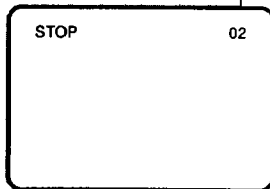

3 Press  **29** until the desired speed appears on-screen.

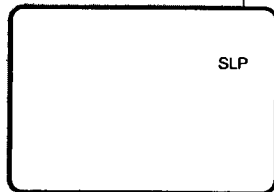

4 Press  **6** (or **n** and **f**) to start recording.

5 Press  **19** (or **g**) to stop recording.

One Touch Recording (OTR)

You can set up the VCR to turn itself off at a preset time making it a one touch timer recording.

In step 4, continue to press  **6** (or **n**) to set the recording length. Each press will change the time as shown in the diagram below.

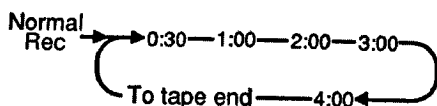

Helpful Notes

- Holding down the CH ∇/\blacktriangle will increase the channel search speed.
- Press PAUSE to pause the recording in progress.

Selecting the Input Mode

Press  **7** to display the menu.

Then, use  **21**

to first, select SET UP VCR and then, to choose TUNER or LINE (LINE1 or LINE2).

- LINE1: For rear audio/video connection.

LINE2: For front audio/video connection.

- You can also select "LINE1" or "LINE2" using the CH ∇/\blacktriangle . The numbers will change in the order shown.

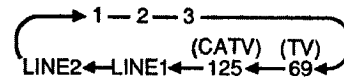

- When LINE is selected, "L1" or "L2" is displayed in the Multi Function Display ().

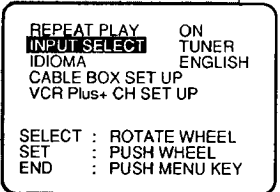
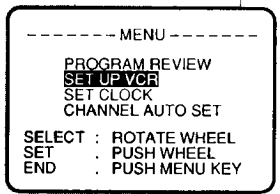

Record One TV Program While Watching Another

Press  **1** (or **b**)

while the recording is in progress to turn off the VCR indicator in the Multi Function Display.

Then, use the TV channel controls

to select a program for viewing.

The VCR will continue to record your program while you watch any channel you choose.

- You can switch back and forth between the channel being recorded and the channel you are viewing by using the VCR/TV button.

Select Channels at the VCR for Recording or Viewing

Turn TV on. Select VCR Channel.

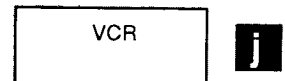

Channel 3 or 4.

This indicator lights in the Multi Function Display. If not, press the VCR/TV button to turn it on.

Then, press  **17** (or **c**) to select channels.

Now, press  **1** (or **b**)

to turn the VCR indicator off, or simply turn the VCR off to select channels with the TV controls.

Copying Your Tapes

Connections you'll need to make.

(Choose front or rear connection.)

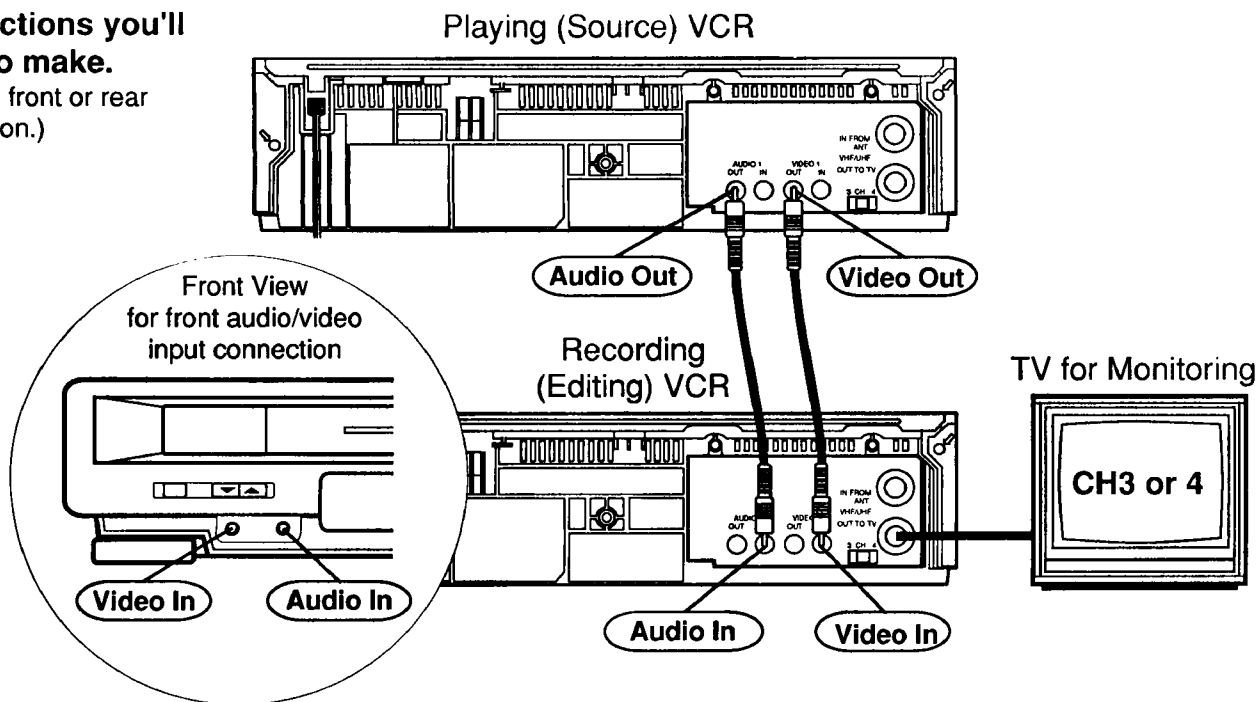

Copying Main Operation

1 Insert a pre-recorded tape into the Playing (Source) VCR.

Then, insert a blank tape with record tab into the Recording (Editing) VCR.

2 Select "LINE" as the input on the Recording VCR.

LINE1: For rear audio/video connection.
LINE2: For front audio/video connection.

• See page 8 for LINE input information.

3 Press PLAY on the Playing VCR.

Then, press PAUSE/ STILL when the tape reaches the point you want to start copying.

4 Press REC and PLAY at the same time on the Recording VCR.

Then, press PAUSE/STILL immediately.

5 Press PAUSE/STILL on both VCRs to begin copying.

Then, press STOP on both VCRs to stop copying.

To Monitor the Re-Recording

Turn the TV on and select its VCR channel (either channel 3 or 4).

Then, set the VCR/TV selector on the Recording VCR to the "VCR" position.

Caution:

Unauthorized exchanging and/or copying of copyrighted recordings may be copyright infringement.

Helpful Note

- By using the PAUSE/ STILL button (on the Recording unit) while copying is in progress, you can edit out unwanted parts of the original recording.

Timer Recording

- Record a program up to one month away.
- Record daily, Monday through Friday.
- Record weekly at the same time.

Before you begin, make sure ...

- if you are going to record from a cable box, please complete pages 12 and 13. • connections are made (see separate Connection Guide).
- TV and VCR are plugged in. • VCR/TV selector is set to "VCR."
- clock is set. • tape is long enough.
- record tab is in place. • all entries are made within 5 minutes.

Easy Timer Programming

1 Press  **20** for program mode.

- If a program has already been set, select a blank program number with the Wheel.

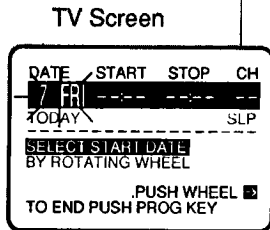

2 Rotate and press  **21**

to select and enter each program item (date, start time, etc.) as it appears on-screen.

Example: Setting the Date

Rotate Wheel Down  TODAY'S DATE  Rotate Wheel Up

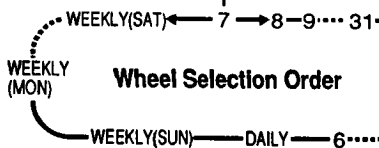

To make corrections, press the Wheel or CLEAR button repeatedly to move back or forward to the desired item.

3 Press  **20** to finish the program.

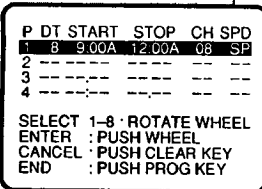

Then, set the next program by repeating steps 2 and 3,

or press  **20** to exit the programming mode.

4 Press  **2** (or **a**) OFF to set the Timer.

The TIMER indicator lights in the Multi Function Display.



Daily/ Weekly Programming

In step 2,

Use  **21**

to enter DAILY or WEEKLY in place of the Date.

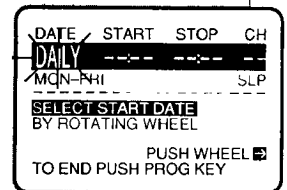

Weekly recordings require that you enter the day of the week. See the "Wheel Selection Order" in step 2 on this page.

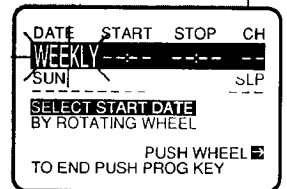

Then, continue with programming.

Review Program Contents

Press  **7** to display the menu.

Then, use  **21** to select PROGRAM REVIEW.

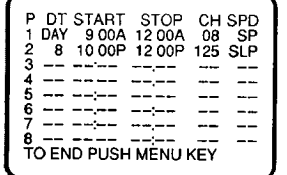

Now, press  **7** twice to return to normal TV.

Helpful Notes

- If you are recording channels from a cable box, the cable box must be left on for timer recording. Also, if the cable box cannot be controlled with the VCR (see page 13), you must manually select the channel to be recorded at the cable box.

Cancel a Timer Recording in Progress

Press  **2** (or **a**) to release the Timer mode.

Then, press  **19** (or **g**) **10** seconds within 10 seconds to cancel the Timer Recording.

Now, press  **2** (or **a**) to turn the VCR OFF.

- Any future daily or weekly recordings will be performed as programmed.

Replace Program Contents

(Recording is not in progress.)

Press  **20** to display all currently set programs.

P	DT	START	STOP	CH	SPD
1	---	---	---	---	---
2	8	10:00P	12:00P	125	SLP
3	10	8:00P	9:00P	10	SP
4	SU	9:00P	10:00P	L	SLP

SELECT 1-8, ROTATE WHEEL
ENTER: PUSH WHEEL
CANCEL: PUSH CLEAR KEY
END: PUSH PROG KEY

Then, use  **21** to select and enter the desired program.

DATE	START	STOP	CH
8 SAT	10:00P	12:00P	125
			SLP

SELECT START DATE BY ROTATING WHEEL
PUSH CLEAR: PUSH WHEEL
TO END: PUSH PROG KEY

Now, press  **20** to return to normal TV.

Clear Program Contents

(Recording is not in progress.)

Press  **20** to display all programs.

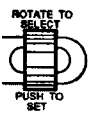
Next, rotate  **21** to select the desired program number.

Then, press  **8** to clear the program.

Now, press  **20** to return to normal TV.

P	DT	START	STOP	CH	SPD
1	DAY	9:00A	12:00A	08	SP
2	8	10:00P	12:00P	125	SLP
3	10	8:00P	9:00P	10	SP
4	SU	9:00P	10:00P	L	SLP

SELECT 1-8, ROTATE WHEEL
ENTER: PUSH WHEEL
CANCEL: PUSH CLEAR KEY
END: PUSH PROG KEY

P	DT	START	STOP	CH	SPD
1	---	---	---	---	---
2	8	10:00P	12:00P	125	SLP
3	10	8:00P	9:00P	10	SP
4	SU	9:00P	10:00P	L	SLP

SELECT 1-8, ROTATE WHEEL
ENTER: PUSH WHEEL
END: PUSH PROG KEY

Helpful Notes

- Another way to review program contents is to first, place the VCR in VCR mode. Then, press the PROGRAM button while a Timer Recording is in progress.
- Check your times carefully to avoid overlapping.
- If the record tab is missing when the power is turned off, the tape ejects and the Timer indicator **TIMER** flashes.
- If there is a power interruption of more than about one minute, the Recording cannot be performed or continue.
- If "PROGRAM IS INCOMPLETE" appears, check all entries carefully and make any corrections. Then, continue with step 3.
- When recording from an external source, rotate the Wheel until "L1 (Rear connection)" or "L2 (Front connection)" appears instead of the Channel.

VCR Plus+ Set Up

This setup is for VCR Plus+ and timer programming only. For TV/Cable Box Universal Remote Control operation, please see page 18.

In order for your VCR to do a VCR Plus+ recording (see top of page 14 for explanation of VCR Plus+), or a timer recording of cable stations, some setup is required. At first, find the antenna or cable connection that matches yours. Then, follow the accompanying instructions.

Choose your Connection Type

(Then, follow the instructions under the diagram.)

A If your system looks like this...

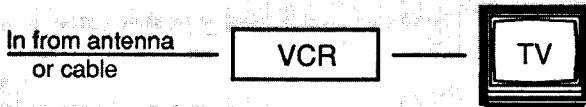

- You may skip page 13.
- Turn to page 14 and complete the VCR Plus+ Set Up steps.
- You are then ready for VCR Plus+ Programming on page 15.

B If your system looks like this...

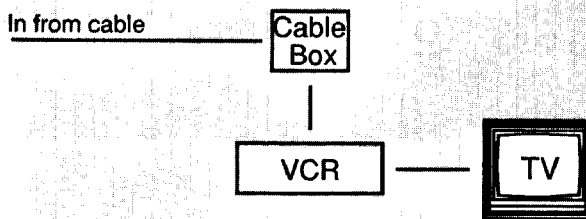

- Turn to page 13 and complete the Cable Box Control steps.
- If your cable box is remote controllable, complete the VCR Plus+ Set Up steps on page 14. If not, you may skip page 14.
- You are then ready for VCR Plus+ Programming on page 15.

Positioning Your Cable Box

(If your Cable Box is controlled by a wireless remote.)

Position your cable box as shown in the diagram. Be sure not to cover up the transmitter window. The VCR transmits an infrared signal from two locations to the cable box.

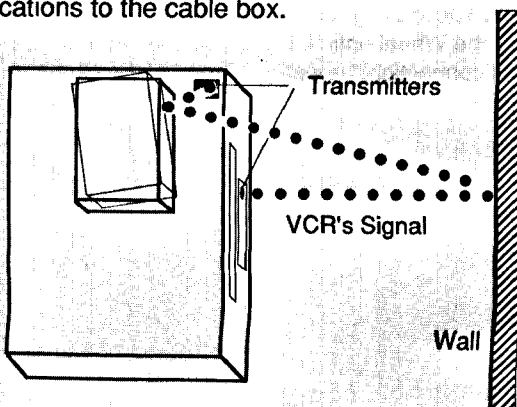

Cable Box Code Numbers

(Refer to this list in step 7 on page 13.)

Archer	29, 44, 76
Archer	42, 44
Cableview	42, 44
Citizen	42, 44
Curtis	08, 09, 56, 61
Diamond	29, 44, 76
Drake	37, 67, 71
Eagle	13, 20, 21, 22, 23, 25, 58, 62
Eastern	28
GC Brand	42, 44
Gemini	4, 30
General Electric	57
General Instruments	01, 02, 03, 04, 55, 75, 83
Hamlin	14, 15
Jerrold	01, 02, 03, 04, 55, 75, 83
Macom, Hitachi	31, 79, 80
Magnavox	13, 20, 21, 22, 23, 25, 26
Movietime	32, 60
Movietime	38, 39, 40
NSC	38, 39, 40
Oak	10, 11, 12, 13, 46, 47
Panasonic	06, 16, 17
Philips	13, 20, 21, 23, 24
Pioneer	05, 06
Pulser	42, 44
RCA	06, 16, 17
Realistic	51, 53
Regal	14, 23, 41
Regency	28
Rembrandt	32, 60
Salora	68, 72
Samsung	04, 06, 42, 78
Scientific Atlantic	08, 09, 56, 61
Sheritech	27
SL Marx	04, 06, 42, 78
Sprucer	06, 16, 17
Stargate	04, 06, 42, 78
Stargate	42, 44
Sylvania	19
Telecaption	77
Teknika	54, 74
Televue	04, 06, 42, 78
Texscan	18, 19
Tocom	33, 34, 48, 49, 73
Toshiba	36, 66, 70
Uniden Satellite	65, 69
Unika	29, 44, 76
Unika	42, 44
Universal	43, 52, 63, 82
Viewstar	13, 20, 21, 22, 23, 25, 58, 62
Vid Tech	64
Vidter	64
Videoway	07, 45, 50, 59
Zenith	07, 45, 50, 59

VCR Plus+ Set Up

This setup is for connection B on page 12 only.

If you receive channels through a cable box, it is necessary to establish a link with the VCR. This is done by entering the cable box output channel (the channel that you tune your TV to in order to watch cable stations) into the VCR's memory. If your cable box is remote controllable, it may be possible for the VCR to automatically change cable box channels for VCR Plus+ and Timer recordings.

Cable Box Control (For connection B on page 12 only)

If your cable box is remote controllable, place it on top of the VCR as shown on page 12.

1 Press  **7** to display the menu.

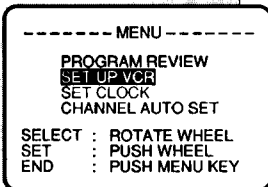

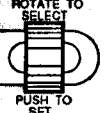
2 Use  **21** to first, select SET UP VCR, and then, to select CABLE BOX SET UP.

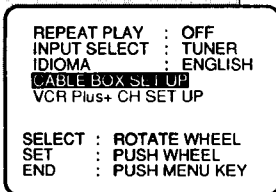

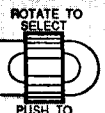
3 Use  **21**

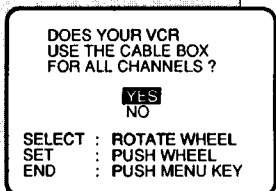

Select **YES** if all channels are received via the cable box (connection B on page 12). Then, go to step 4.

Select **NO** if your cable connection resembles diagram A on page 12. CABLE BOX CONTROL IS NOT AVAILABLE appears on-screen. Press MENU to exit and turn to page 14.

4 Turn on the cable box and manually set it to channel 02. in preparation for step 8.

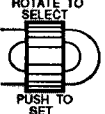
5 Use  **21** to change the displayed number to your cable box output channel (the channel you tune your TV to in order to watch cable stations). If necessary, refer to your cable box manual.

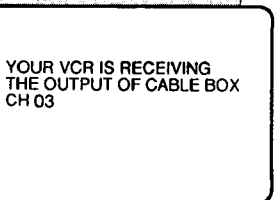
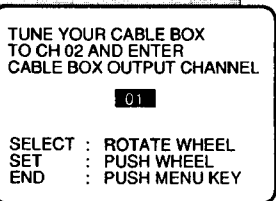

- This screen appears for your confirmation. (Channel shown is example only)
- If you are using Audio/Video jack connection for your cable box, select and set "VIDEO OUT" as the output channel.

Cable Box Control (continued)

6 Press  **7** (or wait 5 seconds) to display the next screen

DOES YOUR CABLE BOX HAVE WIRELESS REMOTE CONTROL?

YES
NO

SELECT : ROTATE WHEEL
SET : PUSH WHEEL
END : PUSH MENU KEY

Then, use  **21**

Select **YES** if your cable box is controlled by a remote control and continue with step 7.

Select **NO** if your cable box is not remote controllable. CABLE BOX CONTROL IS NOT AVAILABLE appears on-screen. Now, press MENU to exit and turn to page 15.

7 Use  **21**

CHOOSE A CODE NUMBER FOR CABLE BOX FROM THE LIST IN OWNER'S MANUAL AND ENTER NUMBER

01

SELECT : ROTATE WHEEL
SET : PUSH WHEEL
END : PUSH MENU KEY

to select and enter the Cable Box Code number that matches your brand from the list on page 12.

NOW TRANSMITTING

IS YOUR CABLE BOX RECEIVING CH 09 ?

YES
NO

SELECT : ROTATE WHEEL
SET : PUSH WHEEL
END : PUSH MENU KEY

8 Use  **21**

Select **YES** if channel 02 on the cable box changes to channel 09. CABLE BOX SET UP COMPLETED appears on screen.

Select **NO** if nothing happens. Try entering the different cable box codes assigned to your brand and/or repositioning the cable box as shown on page 12. If the answer is still NO, cable box control is not available. Finish up with step 9 and turn to page 15.

9 Press  **7** once or twice to return to the normal screen.

If you selected YES in step 8, complete the steps on page 14.

Helpful Note

- Make each entry within 5 minutes in steps 5 and 7, and within 60 seconds for other steps, or the VCR will leave this mode.

VCR Plus+ Set Up

For connection "A" on page 12, or connection "B" if cable box is remote controllable.

VCR Plus+ programming allows you to set most items of a timer recording by simply entering a special code found in *TV GUIDE* magazine as well as the TV listings in selected newspapers. In order for the VCR to read this special code, some set up is required. A Guide (VCR Plus+) channel number is assigned to each local broadcast and cable station. Because this number sometimes differs from the channel your TV receives the station on, it is necessary to program the VCR with local channel information.

Channel Set Up Preparations

NOTE: Complete the steps on this page if your cable box can be controlled with the VCR, or your VCR hook-up resembles "A" on page 12.

Prepare a list like the example below. This list will help you smoothly enter the information needed in step 3 at right.

You will need the following to complete the list:

- A line up of normal and/or cable stations you receive along with the channel numbers your TV receives them on. A cable channel line-up chart is supplied by your cable company.
- A list of Guide (VCR Plus+) channel numbers assigned to the stations you receive. This list is available in *TV Guide* and the TV listings found in selected newspapers.

- 1 Draw a chart with 3 columns like the example below. In the left column, fill in the name or call letters of the stations you receive.
- 2 In the middle column, fill in each station's assigned Guide (VCR Plus+) number found in TV Guide, newspapers, etc.
- 3 In the right column, fill in the channel number that your TV receives the station on from your channel line-up.

EXAMPLE ONLY

Broadcast or Cable Station Name	Assigned Guide (VCR Plus+) channel no.	Channel no. your TV receives the station on
HBO	33	15
Nickelodeon	38	20
CBS	04	04
FOX	11	

VCR Plus+ Channel Set Up

1 Press  **7** to display the menu.

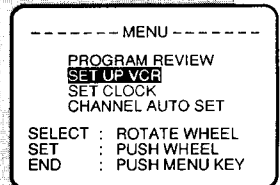

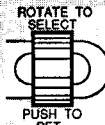
2 Use  to first, select SET UP VCR and then, to select VCR Plus+ CH SET UP.

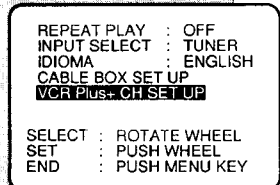

IMPORTANT NOTE:

For step 3, use the list you prepared. You may leave lines blank if, (a) you don't receive that station, or (b) the GUIDE CH number and the CATV (or TV) CH numbers are the same.

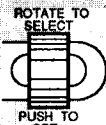
3 Press  to move the shaded area over to the right side of the screen.

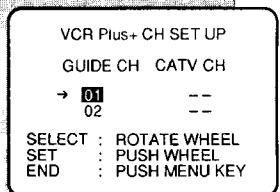

Then, rotate the Wheel to change the number. Next, press the Wheel to enter the number. Now, rotate the Wheel to continue. Repeat this operation until the list is complete.

To Make Corrections

Rotate and press the Wheel to select the incorrect CATV or TV CH number. Then, press CLEAR to delete the numbers. Now, use the Wheel to re-enter the channel.

4 Press  **7** twice to exit the VCR PLUS CH SET UP mode.

Helpful Notes:

- Make each entry within 60 seconds or the VCR will leave this mode.
- Once local channels have been programmed, they will stay in memory, even in the case of a power failure.

VCR Plus+ Programming

Before you begin, make sure ...

- the clock is set.
- VCR Plus+ Channel Set Up is complete (if applicable).
- each entry is made within 60 seconds or VCR leaves this mode.

VCR Plus+ Main Operation

1 Press  **23** to display the VCR Plus screen.

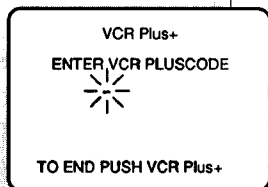

2 Press the NUMBERED Keys to enter the PlusCode number from your local TV listings.

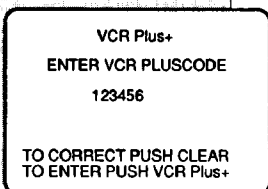

3 Press  **23** to lock in your program.

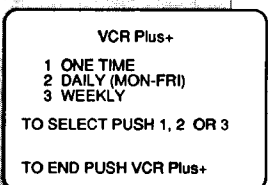

4 Press the 1, 2 or 3 Key to select a ONE TIME, DAILY (MON-FRI) or WEEKLY recording.

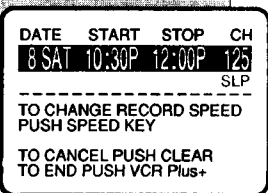

To change the recording speed:

Press the SPEED button for SP LP or SLP.

To cancel program contents:

Press the CLEAR button.

5 Press  **23** to complete the program. This display may differ depending on your cable box hook-up.

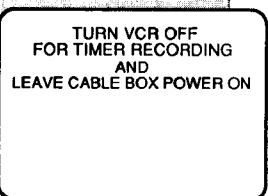

6 Press  **2** off to set the timer. Leave your cable box turned on.

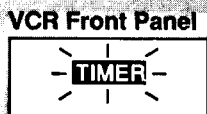

The TIMER indicator lights in the Multi Function Display.

Important:

- Whether or not your cable box can be controlled by the VCR, be sure to leave the cable box turned on for timer recording.
- If your cable box cannot be controlled with the VCR, make sure it is tuned to the desired channel for timer recording.

To Make Corrections

In step 2,

Press  **8** repeatedly to delete the PlusCode number.

Then, enter the correct number.

Use normal Timer Recording steps if:

- the PlusCode for a program is not listed.
- you anticipate the program, such as a sporting event, to run over the scheduled stop time.

See pages 10 and 11 to:

- Review program contents
- Cancel a timer recording in progress
- Clear program contents once set
- Replace program contents

Helpful Notes:

- If you use "B" connection on page 12, but your cable box cannot be controlled with the VCR, the channel shown in the on-screen display in step 4 will always be the cable box output channel number.
- For a list of publications that carry the PlusCode numbers in your area, call 1 - 800 - 258 - 4827.
- You can obtain unlisted PlusCode numbers by calling 1 - 900 - 454 - 7587. Call costs approximately \$.95 per PlusCode number.
- Avoid overlapping program times.
- An on-screen display will indicate if an invalid PlusCode number has been entered.
- An on-screen display will indicate when all timer programs are full.

VCR Plus+ and PlusCode are trademarks of Gemstar Development Corporation. VCR Plus+ system is manufactured under license from Gemstar Development Corporation.

Tape Operation

Repeat Play

You can set your VCR up to play a recording over and over.

1 Press  **7** to display the menu.

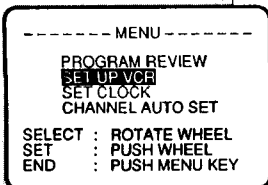

2 Use  **21** to first, select SET UP VCR from the menu; and then, to select REPEAT PLAY : ON.

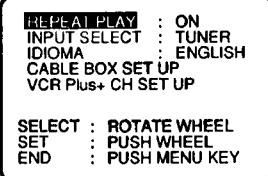

3 Press  **7** again to leave this screen.

- When REPEAT PLAY : "ON" is selected, the VCR will play to the end of a tape, or until it reaches a blank portion 30 seconds or more. (Erased portions of tape are not considered blank.) Then, the VCR will automatically rewind the tape and play it again and again until you cancel repeat play.
- All function buttons (REW, FF, etc.) are operational during Repeat Play.

To Cancel Repeat Play, repeat steps 1 and 2, and select REPEAT PLAY : "OFF". Then press MENU to exit.

Zero Search

Press  **14** to display the Time Counter overlay.

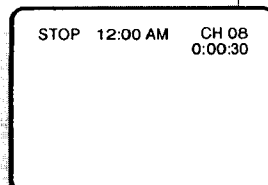

Then, press  **13** to reset the Time Counter to 0:00:00 at whatever point you wish on the tape.

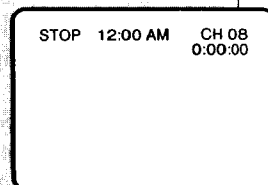

Now, press  **30** in Stop mode. The VCR will go into FF or REW mode. The tape will stop at the last point the Time Counter was set to 0:00:00.

One Minute Skip

With this feature, you can skip over commercials recorded on a tape.

Press  **30** in Play mode. The VCR will go into FF search mode and skip over 60 seconds of recorded time. Then, normal playback will resume.

Auto Operation Functions

Auto Playback

When a tape is inserted, the power comes on (Auto). If the record tab* is removed, playback begins (Auto).

Auto Rewind

After a tape reaches its end during playback, fast forward or manual record, the VCR will rewind it and go into Stop mode.

Playback Auto Eject

After a tape without a record tab* is played to its end, the VCR will rewind and then eject the tape.

Memory Rewind Off

When the POWER button is pressed during rewind, the VCR will turn off after rewind is complete.

Eject Cassette

A cassette may be ejected with power on or off.

* For record tab information, see page 20.

Book Mark Search

Press  **27** in play, FF or STOP mode. The VCR will go into FF mode and then STOP automatically around the end of your recording.

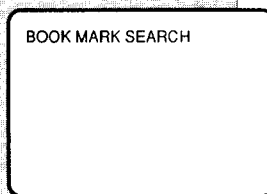

- If the BOOK MARK SEARCH button is pressed where no signal is recorded, the VCR will go into Rewind mode and then stop automatically around the end of your recording.
- Playback a few seconds of tape to find the exact location to start a new recordings.

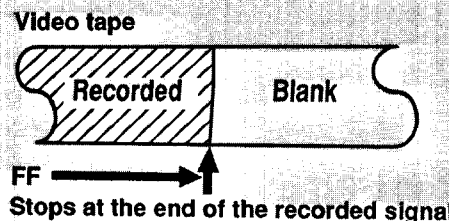

VHS Index Search System

Each time you start a recording, an invisible index mark is automatically placed on the tape. You can then use these index points to locate a particular recording in one of the two ways described below.

Direct Access

This method allows you to go directly to the recording you want from anywhere on the tape by entering a specific index number.

1 Press **INDEX 28** in the Playback or Stop mode.

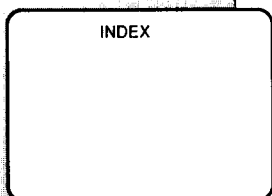

2 Press a **NUMBERED** key to select the desired recording.

- To calculate the number, see below.

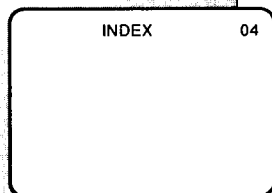

3 Press **REW 5** (or **1**)

or **FF 18** (or **m**)

to start the Index Search forward or backward.

- When the designated location is reached, the VCR goes into Playback mode.

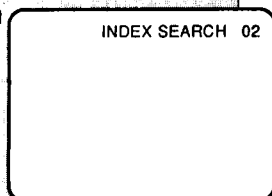

To Select an Index Number

Count forward or backward each recording start point including the recording you want to see from wherever you are on the tape.



Examples:

(1) You are now viewing recording D and you want to see recording B. Count the starting point of D, C and B which adds up to 3. Enter 3 in step 2 and then press the REW button.

(2) You are watching recording B and you want to see recording F. Count the starting point of C, D, E and F which adds up to 4. Enter 4 in step 2 and then press the FF button.

Index Scan

Index Scan allows you to scan (forward or reverse) each recording, first for 7 seconds in Visual Search mode and then for 10 seconds in Playback mode.

1 Press **INDEX 28** in the Playback or Stop mode.

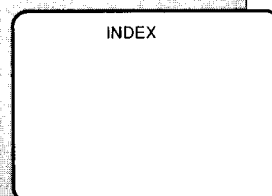

2 Press **REW 5** (or **1**)

or **FF 18** (or **m**)

to begin the scan.

- When each index mark is reached, a short visual search and playback will be performed after which FF or REW resumes.

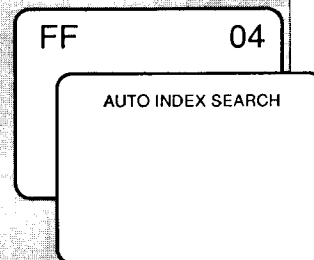

3 Press **PLAY 4** (or **f**)

to cancel the scan and begin playback. Or press the STOP button.

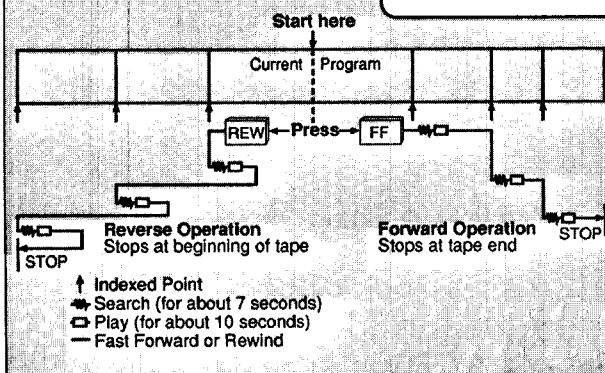
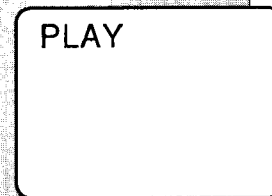

Helpful Notes

- **Make entries within 10 seconds**, or the Index Search mode will be canceled.
- **Index marks will be placed** for Timer recording as well.
- **If the Direct Access index search is initiated** extremely close to an index mark, there is a possibility that the index mark will not be counted in the search.

Setting at the VCR

A timer recording can be set up using the buttons on the VCR. If necessary, the clock can also be set.

Set a Timer Recording at the VCR

VCR Front Panel

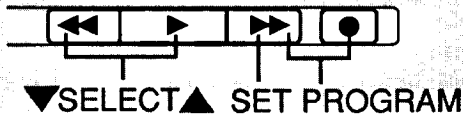

1 Hold down and press to enter the program mode.

• If the clock is not set, pressing these buttons will display the SET CLOCK screen. In this case, proceed with step 2 to set the clock and then to set a timer recording.

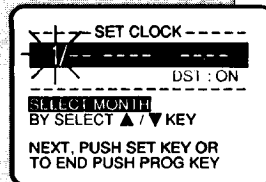
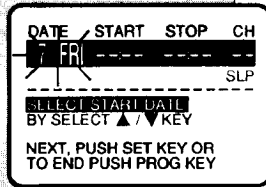

2 Press (for up) or (for down) to make your selection.

Then, press to set and move on to the next item.

When the program is completed, **3** press and (at the same time) to display all program contents.

Then, set the next program by repeating steps 2 and 3,

or, press and again to return to the normal screen.

Helpful Notes

- It is not possible to clear a timer program using the VCR buttons. Please use the Remote Control.
- Press SET (FF) repeatedly to move to a particular item for setting or correction.
- Once the VCR is in the Program mode, the PLAY, REC, FF, and REW buttons on the VCR are non-functional.

Multi-Brand Control Feature

Controlling your TV and Cable Box brand

Your Remote Control may be programmed to control POWER ON/OFF, CHANNEL UP/DOWN, and VOLUME UP/DOWN functions of the TV and Cable Box brands listed below.

- Make sure your TV and/or Cable Box is plugged in and operating properly. Then turn them off with their respective remote controls.

1 Point the remote (packed with your VCR) at your TV or Cable Box.

2 Hold down **22** or **9** and enter your TV or Cable Box brand code number (see below) using the NUMBERED keys. The TV or Cable Box should come on and your remote is now programmed.

TV Brand Code Numbers*

Brand	Code	Brand	Code
Panasonic	01	Sony	08
Quasar		Toshiba	09
Panasonic	02	Sanyo	10
Quasar		Fisher	
RCA	03	JVC	11
GE		Hitachi	12
Zenith	04	Mitsubishi	13
Magnavox	05	Samsung	14
Sylvania		Gold Star	15
Sharp	06	Gold Star	16
Sharp	07	Gold Star	17

Cable Box Brand Code Numbers*

Brand	Code
Panasonic	1
RCA	
Panasonic	2
Scientific-Atlanta	3
	4
Zenith	5
	6
Oak	7
Oak Sigma	
Oak Sigma	8
Jerrold	9

* Due to changes in infra-red commands used by some manufacturers, some TV or Cable Box brands are listed more than once. If, while activating Universal Control, the first code does not power on the TV or Cable Box, please try the next code.

Helpful Notes

- It is necessary to reprogram the remote to control your TV or Cable Box when you replace the remote's batteries.
- The remote control is designed to control the brands listed. However, it will not operate all TVs or Cable Boxes made by these manufacturers.
- Depending on your TV or Cable Box model, not all functions listed may be controlled by this remote control.

Helpful Notes on Operations

Special Playback Features

- During search playback, horizontal noise bars will appear on the TV screen.
- After the VCR is in the Still or Slow mode for 3 minutes it will go into the Stop mode automatically to protect the tape and video head.
- The special effects playback feature is intended for tapes recorded in SP or SLP speed. Tapes recorded in LP mode can also be viewed in special effects playback, but the picture may be completely snowy.

Basic Recording

- While it is possible to change the tape speed when you are recording, there will be some distortion on the tape where the change occurred.
- After the VCR has been in Pause mode for 5 minutes, it will stop automatically to protect the tape and video head.

Timer Recording

- Timer recording may not be performed or continue if a power interruption of more than about 4 hours occurs before or during timer recording, even if power resumes thereafter.
- If the start times of 2 preset programs overlap, the preset time of the lower numbered program will have priority.
- If the preset time for a timer recording comes up during a normal recording or One Touch Recording, the timer recording will not be performed.

D.S.T (Daylight Saving Time)

Spring

First Sunday in April (minus 1 hour)

Because the clock automatically changes from 2AM to 3AM, keep in mind that any part of a scheduled timer recording which falls between these two times will not be performed.

Examples:

A recording set to begin at 1:30AM and end at 2:30 will actually record for 30 minutes.

A recording set to begin at 1:30AM and end at 3:30 will actually record for 1 hour, and so on.

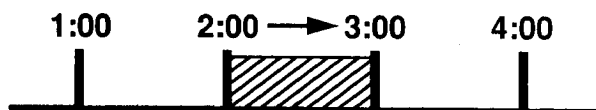

Autumn

Last Sunday in October (plus 1 hour)

The clock automatically changes from 2:00AM back to 1:00AM and therefore affects your recording length.

Examples:

A recording set from 12:50AM to 2:30, will actually record for 2 hours and 40 minutes.

A recording set from 1:00AM to 1:30, will actually record for 30 minutes. (Not affected.)

A recording set from 1:30AM to 2:30, will actually record from 1:30 to 2:00 and then go into the Stop mode until it becomes 1:30 again. The recording will then continue until 2:30 for a total recording time of 1 hour and 30 minutes.

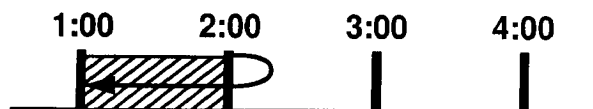

- Even if a recording of a daily or weekly series is affected, other recordings of the series will be performed as programmed.

VCR and Cassette Information

Erase Protection (Record Tab)

Cassettes have a record tab to ensure that recordings are not accidentally erased.

Break off the tab with a screwdriver

to prevent accidental erasure.

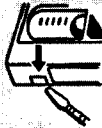

Cover the hole with cellophane tape

to record again.



Maximum Record/Playback Time

Only use tapes with the **VHS** mark in this unit.

Tape Speed Position	Type of Video Cassette		
	T60	T120	T160
SP (Standard Play)	1 Hour	2 Hours	2 Hours 40 Minutes
LP (Long Play)	2 Hours	4 Hours	5 Hours 20 Minutes
SLP (Super Long Play)	3 Hours	6 Hours	8 Hours

Head Cleaner

A clean video head helps produce a clear picture. So we have equipped your VCR with a built-in, non chemical head cleaning system that helps prevent clogging of the video heads. Cleaning is performed each time you load or unload a video cassettes.

Note:

This feature is preventative only. If your video heads are seriously clogged, consider the use of a chemical nonabrasive head cleaning kit or take your VCR to a Servicenter.

Cleaning Care for Video Heads



Clogged Video Head Picture

Clogged Video Heads

Your VCR will not normally require head cleaning, however the heads may become clogged when playing an old or damaged tape. If the image on your screen resembles the image shown above during playback, the heads probably require cleaning.

Cleaning the Heads

It is recommended that head cleaning be performed by a qualified service technician. Please contact your nearest Panasonic Service Center. An alternate solution is to obtain a head cleaning cassette. Be sure to follow the cleaning instructions carefully. Excessive use of a cleaning cassette could shorten head life. Use this cassette only when symptoms occur.

Product Specifications

Power Source:	120V AC, 60 Hz
Power Consumption:	Approx. 18 watts
Video Signal:	EIA Standard NTSC color
Video Recording System:	4 rotary heads helical scanning system
Audio Track:	1 track
Tuner:	
Broadcast Channels:	VHF 2~13, UHF 14~69
CATV Channels:	Midband A through I (14~22) Superband J through W (23~36) Hyperband AA~EEE (37~64) Lowband A-5~A-1 (95~99) Special CATV channel 5A (01) Ultraband 65~94, 100~125
Operating Temperature:	41°F~104°F (5°C~40°C)
Operating Humidity:	10%~75%
Weight:	8.2 lbs. (3.7 Kg)
Dimensions:	14-15/16" (W) X 3-1/2" (H) X 11-1/4" (D) 380 (W) X 89 (H) X 285 (D) mm

Note: Designs and specifications are subject to change without notice.

Multi Function Display

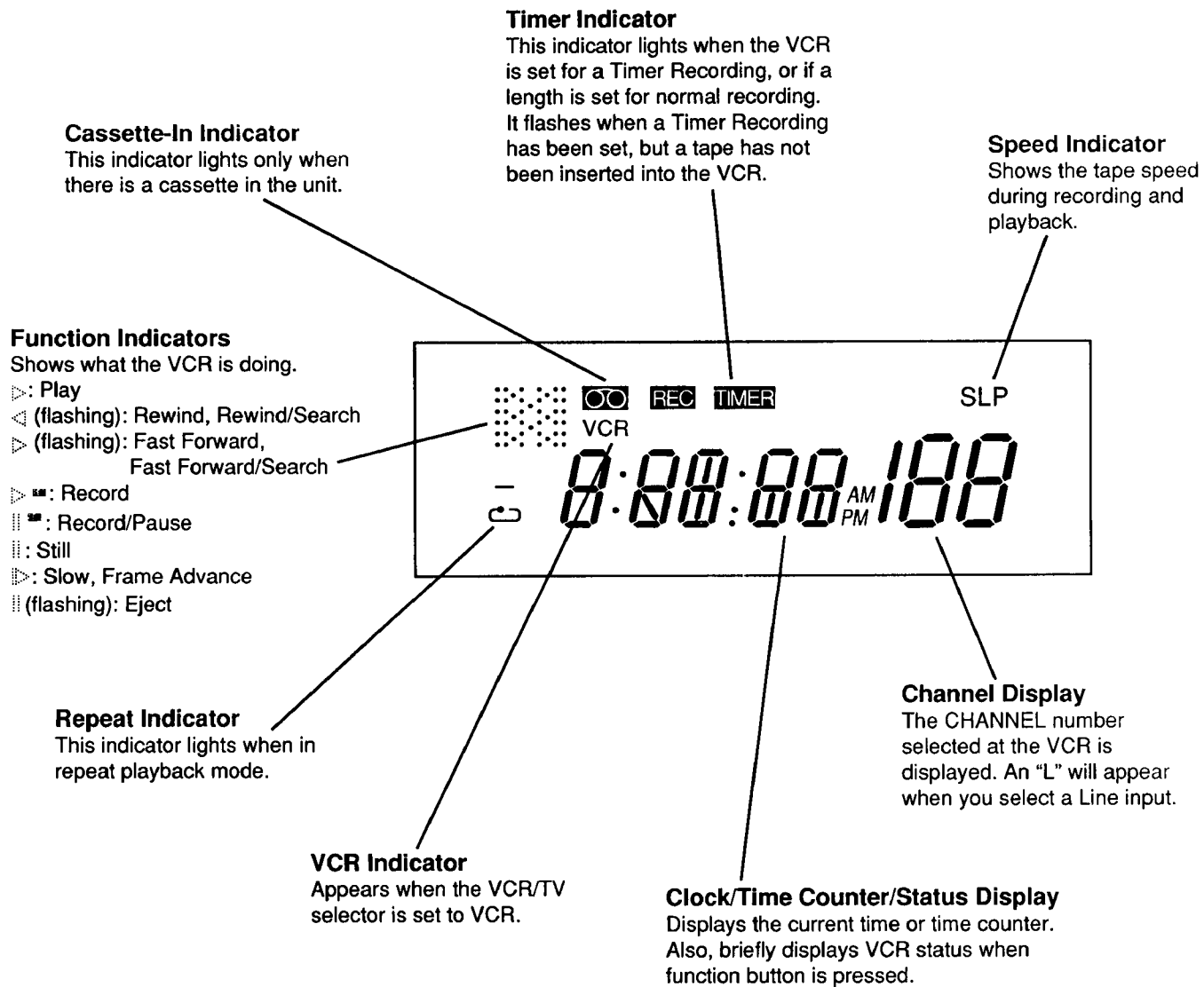

Rear View of the VCR

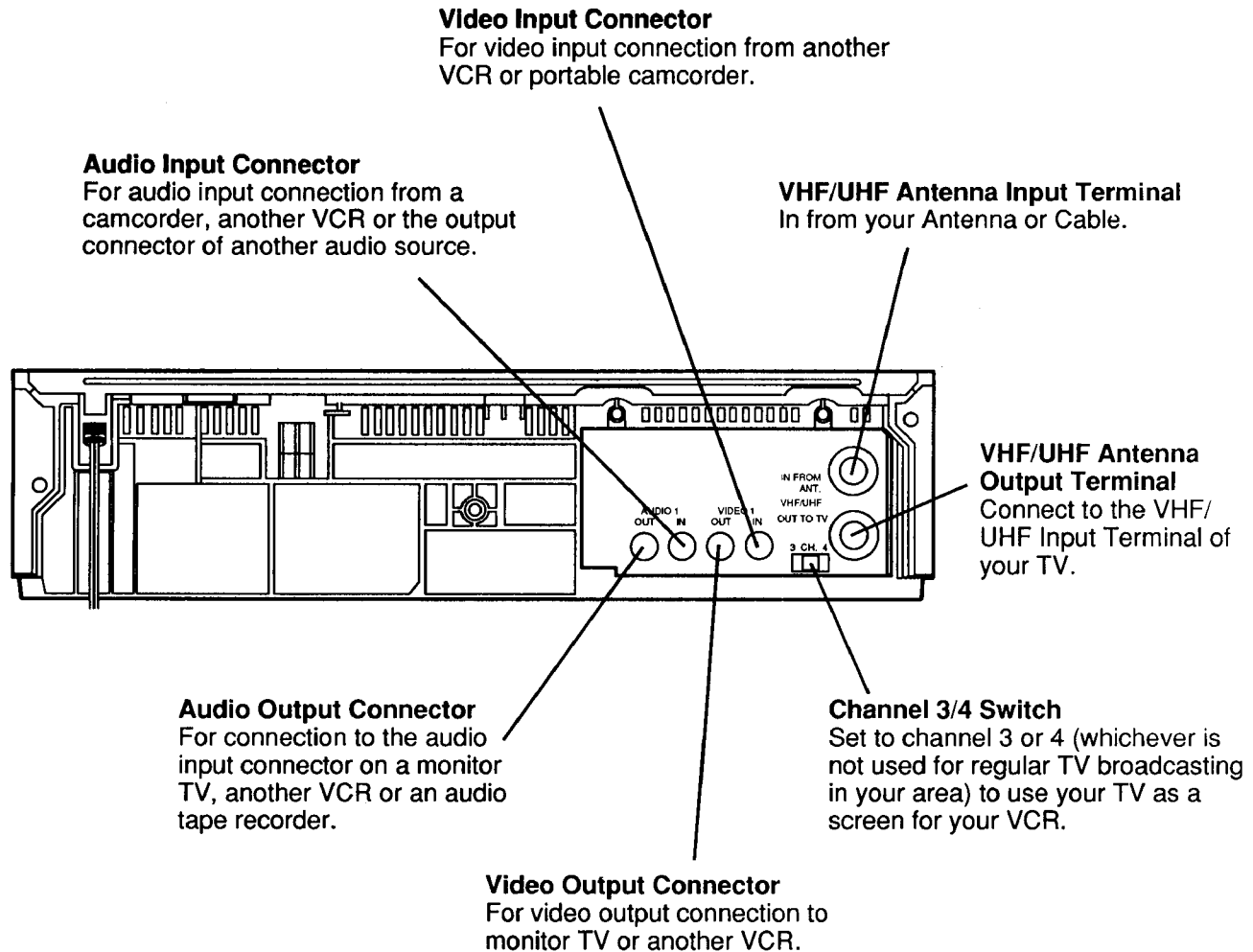

Before Requesting Service

Check the following points once again if you are having some trouble with your VCR.

Power	Correction
No power...	<ul style="list-style-type: none"> • Check that the Power Plug is completely connected to an AC outlet. • Check that the POWER button is set to on.
Recording & Playback	Correction
TV program can't be recorded...	<ul style="list-style-type: none"> • Check the connections between the VCR, the external antenna, and your TV. • Check that the band selected matches your antenna or cable TV system. (P.5) • Make sure that the record tab on the back of the cassette is still intact. (P.20)
Timer recording can't be performed...	<ul style="list-style-type: none"> • Set the recording start/stop times correctly. (P.10) • Make sure that the POWER button is set to off. (P.10) • Timer recording may not be performed or continued if a power interruption of more than 4 hours occurs before or during Timer Recording, even if power resumes thereafter.
There is no playback picture, or the playback picture is noisy or contains streaks...	<ul style="list-style-type: none"> • Select the same channel on your TV as that of the Channel 3/4 switch located on the rear panel of the VCR. (Separate Connection Guide) • Set the VCR/TV selector to "VCR". (P.7) • Check that channel 3 or 4 of the TV is properly adjusted. • Adjust the TRACKING control slowly in either direction. (P.7)
During special effects playback, the picture may contain some vertical jitter when using a TV which has an Automatic Vertical Hold Control...	<ul style="list-style-type: none"> • Set the TV's Vertical Hold Control to "MANUAL" and then adjust it.
If the top of your playback picture waves back and forth excessively...	<ul style="list-style-type: none"> • Because the VCR playback signal is not as stable as an off-the-air TV signal, the top of your TV screen may be bent or unstable during playback. To solve this problem, slowly turn the horizontal hold control on your TV to correct the wavy picture. If your TV does not have a horizontal hold control or adjusting the control does not help, please contact your local TV service center.

<i>Remote Control</i>	<i>Correction</i>
<p>VCR can't be remote controlled...</p>	<ul style="list-style-type: none"> • Aim the Remote Control directly at the remote sensor on the VCR. (Refer to Control Reference Guide.) • Avoid all obstacles which may interfere with the signal path. • Inspect or replace the batteries (P.2).
<i>Miscellaneous</i>	<i>Correction</i>
<p>You can't view programs normally on TV...</p> <p>Video cassette can't be inserted...</p> <p>Video cassette can't be removed...</p> <p>Video cassette ejects when the REC and PLAY buttons are pressed or when the POWER button is pressed off to set the Timer...</p> <p>In the stop mode, the motor (CYLINDER) continues to rotate...</p>	<ul style="list-style-type: none"> • Set the VCR/TV selector to "TV". (P.8) • Insert the cassette with the window side up and the record tab facing you. • Check that the power plug is completely connected to an AC outlet. • Make sure the record tab on the back of the cassette is still intact. (P.20) • To enable the quick play mechanism, the cylinder will rotate for about 10 minutes. • The quick play mechanism reduces response time from stop to PLAY mode from PLAY to REWIND search mode.

Quick Use Guide

This guide should only be used once you are familiar with the operations inside this manual. If you have any problems or need more information, please refer to the page listed.

Clock Reset (page 5)

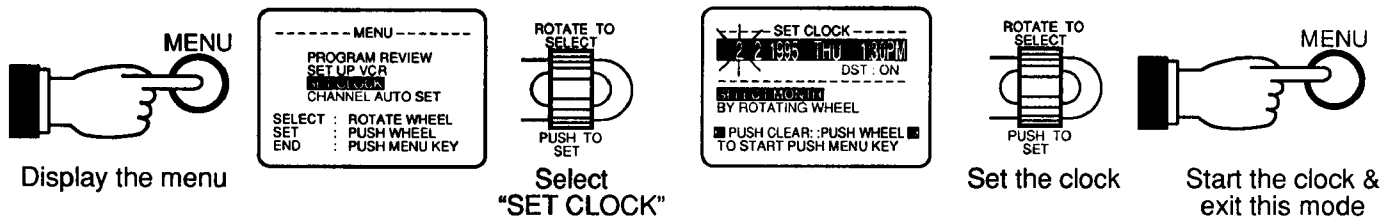

Playback a Tape (page 7)

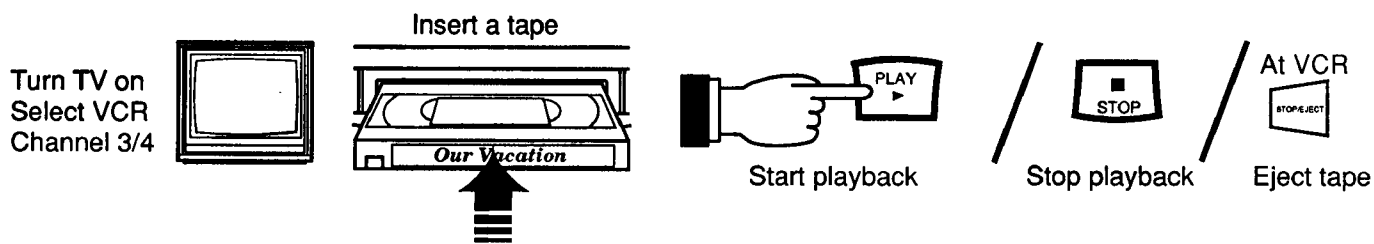

Make a Recording (page 8)

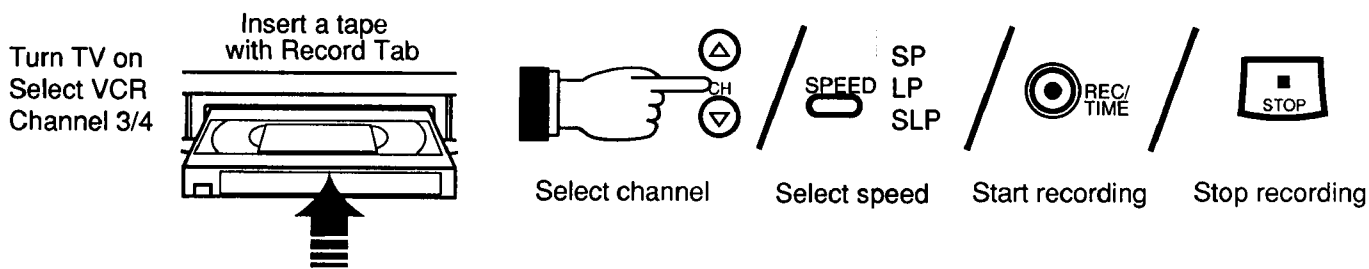

Set a Timer Recording (page 10)

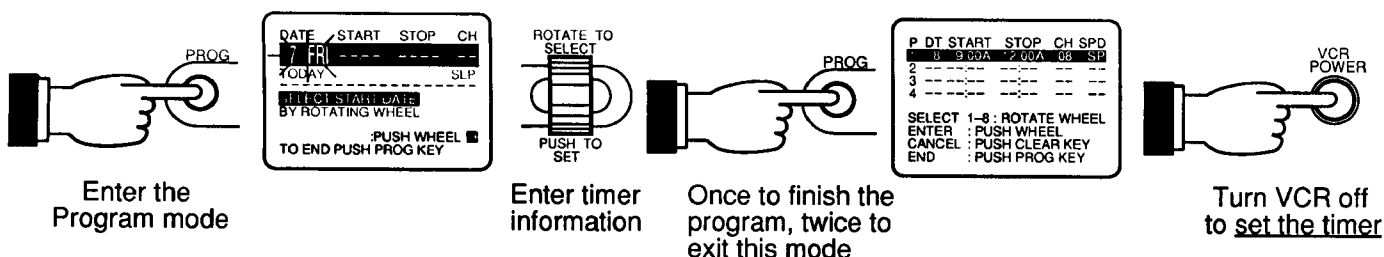

Panasonic®

Panasonic Company
Division of Matsushita Electric
Corporation of America
One Panasonic Way, Secaucus,
New Jersey 07094

Panasonic Company
(West) of America.
Division of Matsushita Electric
Corporation of America
6550 Katella Ave.
Cypress, CA 90630

Panasonic Sales Company
Division of Matsushita Electric
of Puerto Rico, Inc.
San Gabriel Industrial Park
65th Infantry Avenue KM 9.5
Carolina, Puerto Rico 00630