

HITACHI

SOLID STATE COLOR TV

27CX7B

27CX75B

OPERATING GUIDE



IMPORTANT SAFEGUARDS

2-5



FIRST TIME USE

6-15



THE REMOTE CONTROL

16-28

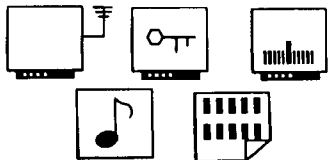

COLOR GRAPHIC GUIDE

29-44

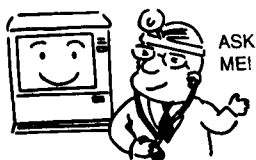





**USEFUL INFORMATION
INDEX**

45-51



IMPORTANT

Follow all warnings and instructions marked on this television receiver.

	CAUTION RISK OF ELECTRIC SHOCK DO NOT OPEN			The lightning flash with arrowhead symbol, within an equilateral triangle, is intended to alert the user to the presence of uninsulated "dangerous voltage" within the product's enclosure that may be of a sufficient magnitude to constitute a risk of electric shock to persons.
CAUTION: TO REDUCE THE RISK OF ELECTRIC SHOCK, DO NOT REMOVE COVER (OR BACK) NO USER SERVICEABLE PARTS INSIDE REFER SERVICING TO QUALIFIED SERVICE PERSONNEL.				The exclamation point within an equilateral triangle is intended to alert the user to the presence of important operating and maintenance (servicing) instructions in the literature accompanying the appliance.

WARNING:

TO PREVENT FIRE OR SHOCK HAZARD, DO NOT EXPOSE THIS TELEVISION SYSTEM TO RAIN OR MOISTURE.

NOTE: There are no user serviceable parts inside the receiver. Model number and serial number are indicated on back side of the set.

POWER SOURCE

This HITACHI color TV is designed to operate on 120 volts 60Hz, AC household current. Insert power cord into a 120volt 60Hz outlet.

TO PREVENT ELECTRIC SHOCK, DO NOT USE THE TELEVISION'S PLUG WITH AN EXTENSION CORD, RECEPTACLE, OR OTHER OUTLET UNLESS THE BLADES AND GROUND TERMINAL CAN BE FULLY INSERTED TO PREVENT BLADE EXPOSURE.

NEVER CONNECT THE TV TO 50 Hz, DIRECT CURRENT, OR ANYTHING OTHER THAN THE SPECIFIED VOLTAGE.

NOTE: This television receiver will display television closed captioning, (CC or C), in accordance with paragraph 15.119 of the FCC rules.



CAUTION: Never remove the back cover of the set as this can expose you to very high voltages and other hazards. If the set does not operate properly, unplug the set and call your dealer or service shop.

IMPORTANT



IMPORTANT SAFEGUARDS

CAUTION:

- * Read all of these instructions
- * Save these instructions for later use.
- * Follow all warnings and instructions marked on the television receiver.

SAFETY POINTS YOU SHOULD KNOW ABOUT YOUR HITACHI TELEVISION RECEIVER

Our reputation has been built on the quality, performance, and ease of service of HITACHI television receivers.

Safety is also foremost in our minds in the design of these units. To help you operate these products properly, this section illustrates safety tips which will be of benefit to you. Please read it carefully and apply the knowledge you obtain from it to the proper operation of your HITACHI television receiver.

Please fill out your warranty card at once and mail it to HITACHI. This will enable HITACHI to notify you promptly in the improbable event that a safety problem should be discovered in your model of product.

FOR YOUR PERSONAL SAFETY

1. This television set is equipped with a polarized alternating-current line plug (a plug having one blade wider than the other.) This plug will fit into the power outlet only one way. This is a safety feature. If you are unable to insert the plug fully into the outlet, try reversing the plug. If the plug should still fail to fit, contact your electrician to replace your obsolete outlet. Do not defeat the safety purpose or the polarized plug.



2. When the power cord or plug is damaged or frayed, unplug this television set from the wall outlet and refer servicing to qualified service personnel.



3. Do not overload wall outlets and extension cords as this can result in fire or electric shock.



4. Do not allow anything to rest on or roll over the power cord, and do not place the TV where the power cord is subject to traffic or abuse. This may result in a shock or fire hazard.



5. Do not attempt to service this television set yourself as opening or removing covers may expose you to dangerous voltage or other hazards. Refer all servicing to qualified service personnel.



6. Never push objects of any kind into this television set through cabinet slots as they may touch dangerous voltage points or short out parts that could result in a fire or electric shock. Never spill liquid of any kind on the television set.

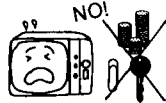

7. If the television set has been dropped or the cabinet has been damaged, unplug this television set from the wall outlet and refer servicing to qualified service personnel.

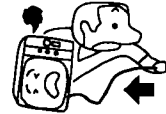

8. If liquid has been spilled into this television set, unplug it from the wall outlet and refer service to qualified service personnel.



9. Do not subject your television set to impact of any kind. Be careful not to damage the picture tube surface.



10. Unplug this television set from the wall outlet before cleaning. Do not use liquid cleaners or aerosol cleaners. Use a damp cloth for cleaning.



11-1. Do not place this television set on an unstable cart, stand, or table. The television set may fall, causing serious injury to a child or an adult, and serious damage to the appliance. Use only with a cart or stand recommended by the manufacturer, or sold with the television set. Wall or shelf mounting should follow the manufacturer's instructions, and should use a mounting kit approved by the manufacturer.



11-2. An appliance and cart combination should be moved with care. Quick stops, excessive force, and uneven surfaces may cause the appliance and cart combination to overturn.



PROTECTION AND LOCATION OF YOUR SET

12. Do not use this television set near water, for example, near a bathtub, washbowl, kitchen sink, or laundry tub, in a wet basement, or near a swimming pool, etc.



• Never expose the set to rain or water. If the set has been exposed to rain or water, unplug the set from wall outlet and refer to qualified service personnel.



13. Choose a place where light (artificial or sunlight) does not shine directly on the screen.



14. Avoid dusty places, since accumulated dust inside the chassis may cause failure of the set when high humidity persists.

15. The set has slots, or openings in the cabinet for ventilation purposes, to provide reliable operation of the receiver, and to protect from overheating. These openings must not be blocked or covered.

- Never cover the slots or openings with cloth or other material.
- Never block the bottom ventilation slots of the set by placing it on a bed, sofa, rug, etc.
- Never place the set near or over a radiator or heat register.
- Never place the set in a "built-in" enclosure, unless proper ventilation is provided.





IMPORTANT

PROTECTION AND LOCATION OF YOUR SET

16-1. If an outside antenna is connected to the television set, be sure the antenna system is grounded so as to provide some protection against voltage surges and built up static charges, Section 810 of the National Electrical Code, NFPA No. 70-1975, provides information with respect to proper grounding of the mast and supporting structure, grounding of the lead-wire to an antenna discharge unit, size of grounding conductors, location of antenna discharge, connection to grounding electrode, and requirements for the grounding electrode.

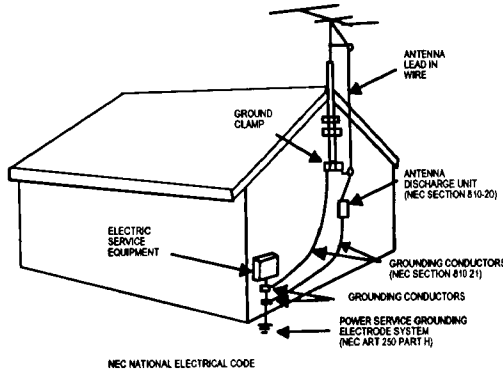

EXAMPLE OF ANTENNA GROUNDING AS PER NATIONAL ELECTRICAL CODE INSTRUCTIONS.

16-2. **Note to CATV system installer:**

(Only for the television set with CATV reception)
This reminder is provided to call CATV system installer's attention to Article 820-40 of the NEC that provides guidelines for proper grounding and, in particular, specifies that the cable ground shall be connected to the grounding system of the building, as close to the point of cable entry as practical.

17. An outside antenna system should not be located in the vicinity of overhead power lines or other electrical lights or power circuits, or where it can fall into such power lines or circuits. When installing an outside antenna system, extreme care should be taken to keep from touching such power lines or circuits as contact with them might be fatal.

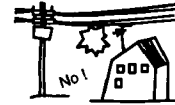

18. For added protection for this television set during a lightning storm, or when it is left unattended and unused for long periods of time, unplug it from the wall outlet and disconnect antenna. This will prevent damage due to lightning and power-line surges.



OPERATION OF YOUR SET

19. This television set should be operated only from the power source indicated on the marking label. If you are not sure of the type of power supply at your home, consult your television dealer or local power company. For television sets designed to operate from battery power, refer to the operating instructions.



20. If the television set does not operate normally by following the operating instructions, unplug this television set from the wall outlet and refer servicing to qualified service personnel. Adjust only those controls that are covered in the operating instructions and improper adjustment of other controls may result in damage and will often require extensive work by a qualified technician to restore the television set to normal operation.



21. When going on a holiday: If your television set is to remain unused for a period of time, turn the television set "OFF" and unplug it from the wall outlet.



IF THE SET DOES NOT OPERATE PROPERLY

22. If you are unable to restore normal operation by following the detailed procedure in your operating instructions, do not attempt any further adjustments. Unplug the set and call your dealer or service technician.



23. Whenever the television set is damaged or fails, or a distinct change in performance indicates a need for service, unplug the set and have it checked by a professional service technician.

24. It is normal for some TV sets to make occasional snapping or popping sounds, particularly when being turned on or off. If the snapping or popping is continuous or frequent, unplug the set and consult your dealer or service technician.

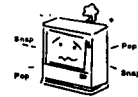

FOR SERVICING AND MODIFICATION

25. Do not use attachments not recommended by the television set manufacturer as they may cause hazards.

26. When replacement parts are required, be sure the service technician has used replacement parts specified by the manufacturer that have the same characteristics as the original part. Unauthorized substitutions may result in fire, electric shock, or other hazards.



27. Upon completion of any service or repairs to the television set, ask the service technician to perform routine safety checks to determine that the television is in safe operating condition.





WARNING

Continuous on-screen displays such as video games, stock market quotations, computer generated graphics, and other fixed (non-moving) patterns can cause permanent damage to color television receivers. Such "PATTERN BURNS" constitute misuse and are NOT COVERED by your Hitachi Factory Warranty.

When using the Picture-in-Picture function, the sub-picture should not be left permanently in one corner of the screen or a "PATTERN BURN" may develop over a long period of time.

This Color Television receiver was intended mainly for the private viewing of programs broadcast by TV stations, cable companies, and programs from other video sources. Public viewing may require prior authorization from the broadcaster or owner of the video program.



ACCESSORIES

Check that you have the following accessories before disposing of the packing material.

1. Remote Control Unit CLU-418U (Part No. HL00234) and CLU-419UI (Part No. HL00229).
2. Two "AA" size, 1.5V batteries (For Remote Control Unit).

For information regarding how to obtain these accessories, please call TOLL FREE 1-800-448-2244 for your nearest HITACHI Authorized Parts Distributor in the continental United States. For Alaska and Hawaii, please contact your nearest HITACHI regional office.

PART NAME	PART NO	ILLUSTRATION	
<p>27CX7B CLU-418U REMOTE TRANSMITTER</p>	HL00234		
<p>27CX75B CLU-419UI REMOTE TRANSMITTER</p>	HL00229		
<p>27V TELEVISION STAND SP271B (Not included, order separately)</p>	H530021		<p>CUSTOM HITACHI TELEVISION STAND</p> <p>Excellent for VCR and videotape storage. Special Features: curved smoke glass doors, adjustable shelf. Available in Black.</p>

 **CAUTION:** The television stand model SP271B is designed for use only with HITACHI TV models 27CX7B and 27CX75B. Use with other television equipment may result in instability, causing possible injury.

REMOTE CONTROL BATTERY INSTALLATION AND REPLACEMENT



1. Open the battery cover of the remote transmitter by pushing the notched part of the cover with your fingers.
2. Insert two new "AA" size batteries in the remote. When replacing old batteries, push them towards the springs and lift them out.
3. Match the batteries to the (+) and (-) marks in the battery compartment.
4. Replace the cover.

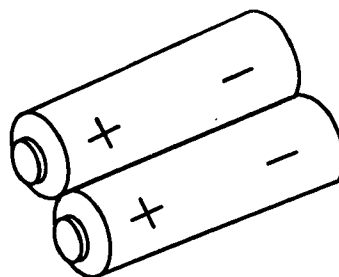

BOTTOM VIEW

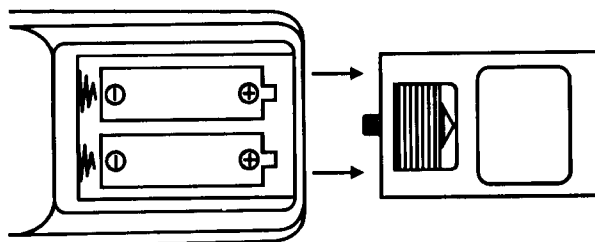

CAUTIONS

1. If your television set is to remain unused for a long period of time, for instance, when you go on vacation, unplug the television from the wall outlet.
2. Do not subject the remote transmitter to shocks such as dropping it on the floor, etc. Precision parts may be damaged.
3. Do not allow the remote transmitter to become wet and avoid placing it in areas of high humidity. Don't leave it on or near a heater. Excess heat or moisture may cause the unit to cease operation.
4. If the batteries become exhausted, remote control operation may become erratic or stop altogether. Replace the old batteries with fresh "AA" (SUM-3) types.

NOTES:

1. The Channel No. Indication, Volume Indication and OFF TIMER Indication are not displayed simultaneously.
2. To operate your TV, point the remote transmitter at the remote sensor of the TV.



HOW TO SET UP YOUR NEW HITACHI COLOR TV

ANTENNA

Unless your TV is connected to a cable TV system or to a centralized antenna system, a good outdoor color TV antenna is recommended for best performance. However, if you are located in an exceptionally good signal area that is free from interference and multiple image ghosts, an indoor antenna may be sufficient.

LOCATION

Select an area where sunlight or bright indoor illumination will not fall directly on the picture screen. Also, be sure that the location selected allows a free flow of air to and from the back cover of the set.

To avoid cabinet warping, cabinet color changes, and increased chance of set failure, do not place the TV where temperatures can become excessively hot. For example, in direct sunlight or near a heating appliance, etc.

VIEWING

The major benefit of the HITACHI Color Television is its large viewing screen. To see this screen at its best, test various locations in the room to find the best spot for viewing. The drawings give several suggestions.

The best picture is seen by sitting directly in front of the TV and about 6 to 9 feet from the screen. During daylight hours, reflections from outside light may appear on the screen. If so, drapes or screens can be used to reduce the reflection or the TV can be located in a different section of the room.

If the TV's audio output will be connected to a Hi-Fi system's external speakers, the best audio performance will be obtained by placing the speakers equidistant from each side of the receiver cabinet and as close as possible to the height of the picture screen center. For best stereo separation, place the external speakers at least 4 feet from the side of the TV. Place the surround speakers to the side or behind the viewing area. Differences in room sizes and acoustical environments will require some experimentation with speaker placement for best performance.

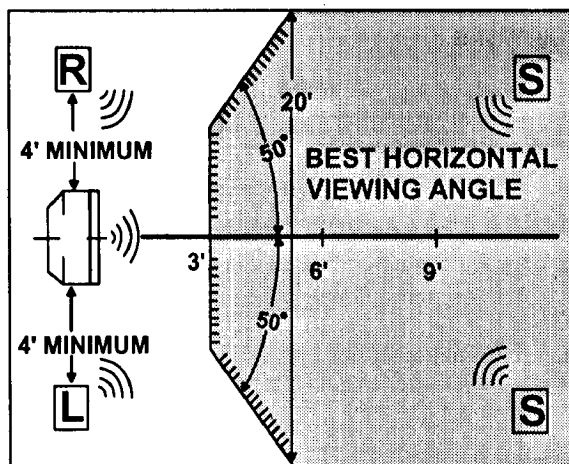
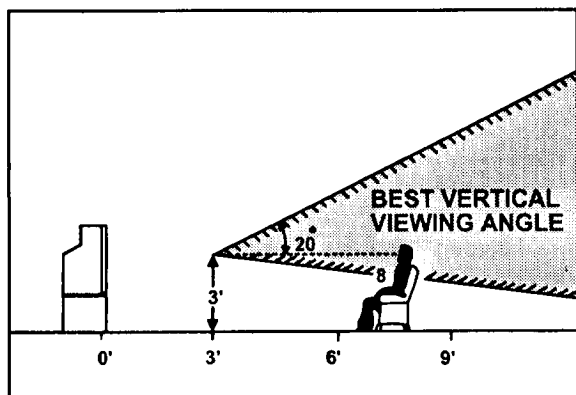

CAUTION: The magnetic field of external speakers may cause the picture to distort if the speakers are placed too close to the television. Move the speakers away from the TV until there is no picture distortion.

HOOKUP CABLES AND CONNECTORS



Most video/audio connections between components can be made with shielded video and audio cables that have phono connectors. For best performance, video cables should use 75-Ohm coaxial shielded wire. Cables can be purchased from most stores that sell audio/video products. Below are illustrations and names of common connectors. Before purchasing any cables, be sure of the output and input connector types required by the various components. Also make sure the cables are the correct length.

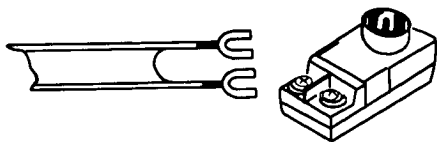

300-Ohm Twin Lead Connector

This outdoor antenna cable must be connected to an antenna adapter (300-Ohm to 75-Ohm).



"F" Type 75-Ohm Coaxial Antenna Connector

For connecting RF signals (antenna or cable TV) to the antenna jack on the television.



Phono Connector

Used on all standard video and audio cables which connect to inputs and outputs located on the Television's rear jack panel and front control panel.



S-Video (Super Video) Connector

This connector is used on camcorders, VCR's and laser disc players with an S-Video feature in place of the standard video cable to produce a high quality picture.

1. VHF (75 OHM) ANTENNA/CATV

When using a 75 Ohm coaxial cable system, disconnect the VHF adaptor from the VHF 75 Ohm receptacle and connect the outdoor antenna or CATV cable to a VHF 75 Ohm receptacle.

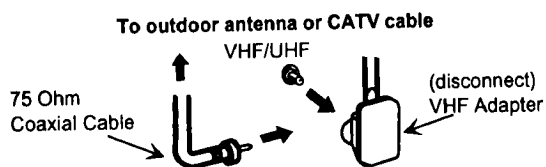

3. When both VHF and UHF antennas are connected

Attach an optional ANT.MIXER to the TV antenna terminal and connect the cables to the ANT. MIXER.

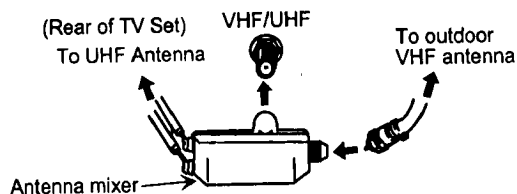

2. VHF (300 Ohm) antenna/UHF antenna

When using a 300 Ohm twin lead from an outdoor antenna disconnect the (VHF or UHF) indoor antenna leads from screws of the (VHF or UHF) adaptor, and connect outdoor (VHF or UHF) antenna leads to these screws of a (VHF or UHF) adaptor.

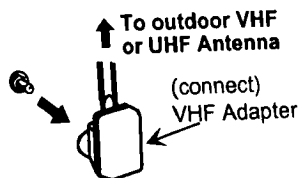

Notes:

1. If an outdoor antenna/CATV is to be used, disconnect the indoor antenna. Do not leave both the indoor and outdoor antennas/CATV connected at the same time, since ghosting and poor reception may result.
2. Consult your dealer or service store for the ANT.MIXER and (VHF or UHF) adaptor.
3. The special converter (decoder) will be supplied by the cable company.



FRONT PANEL CONTROLS FOR 27CX7B AND 27CX75B

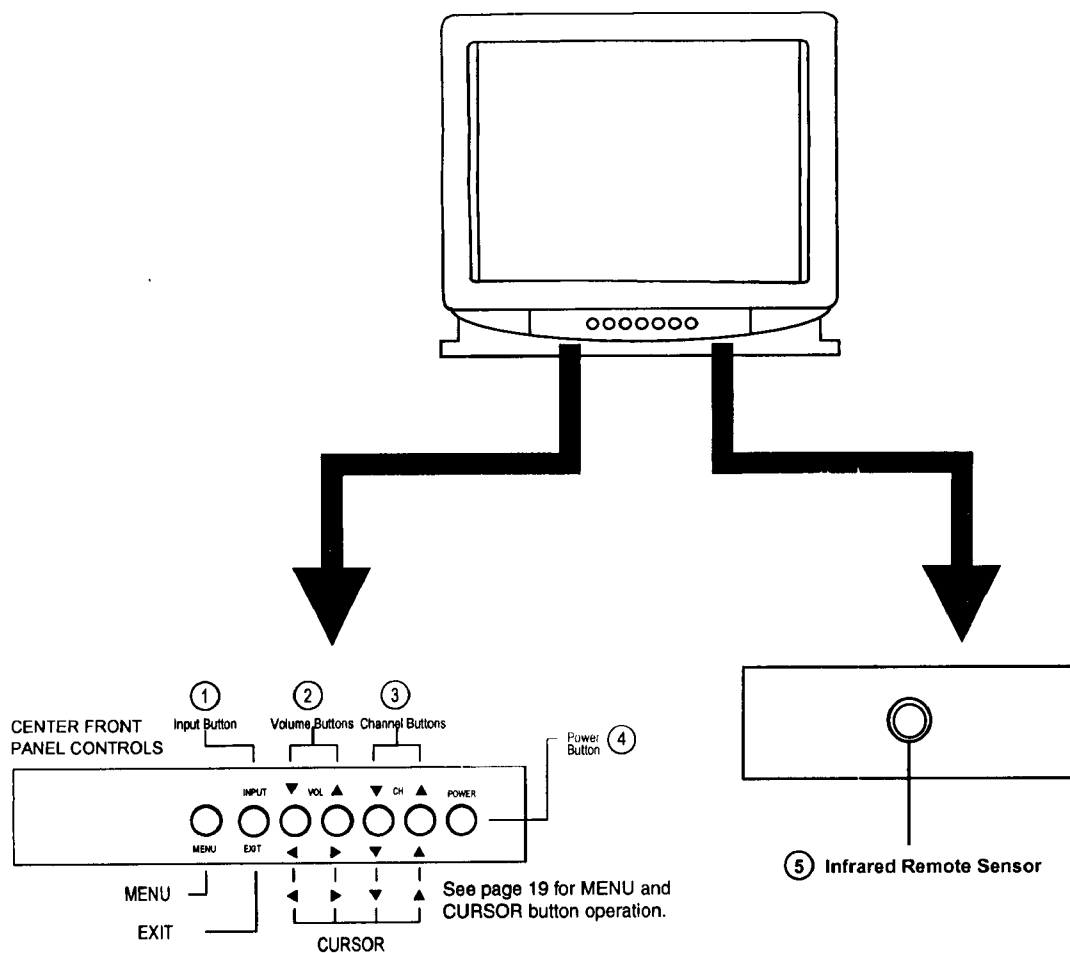

NOTE: CURSOR operation will not operate the FAMILY FAVORITES channel function from the front panel control.

- ① **INPUT Selector**
Press this button to select the current antenna source or VIDEO. Your selection is shown in the top right corner of the screen.
- ② **VOLUME Level**
Press these buttons for your desired sound level. The volume level will be displayed on the TV screen.
- ③ **CHANNEL Selector**
Press these buttons until the desired channel appears in the top right corner of the TV screen.
- ④ **POWER Button**
Press this button to turn the TV on or off.

NOTE: Your HITACHI TV will appear to be turned "OFF" if there is no video input when VIDEO is selected. If you have no input to VIDEO, press the INPUT button until the normal broadcast picture appears. If the picture does not appear, the power is "OFF". Check the Power Light to make sure the TV is off when not in use.

- ⑤ **REMOTE CONTROL Sensor**
Point your remote at this area when selecting channels, adjusting volume, etc.

REAR PANEL JACKS

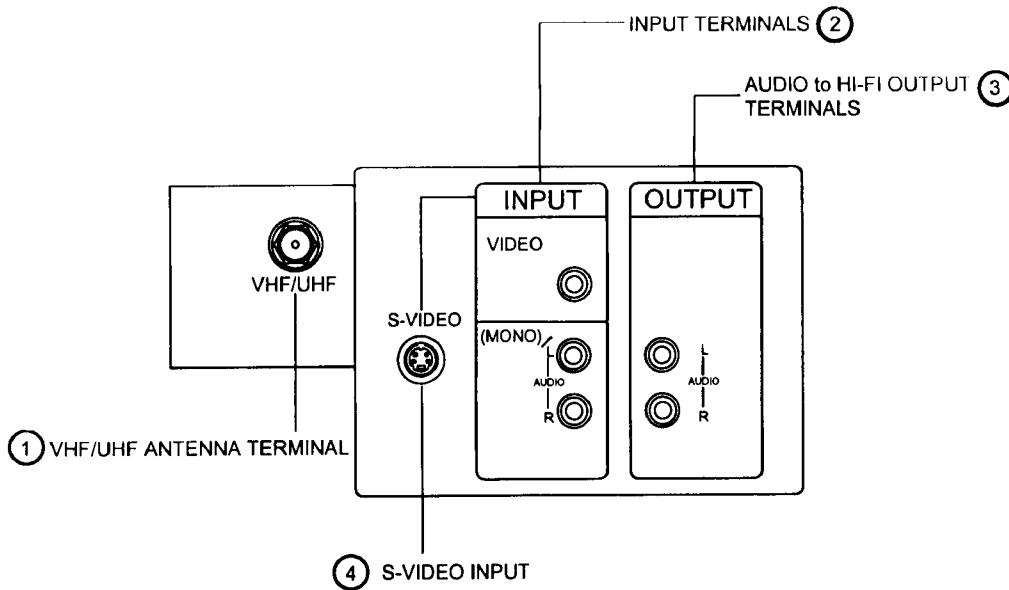

① Antenna Inputs

The VHF/UHF terminal can be used for normal TV, cable TV (CATV), a TV game, etc.

② Audio/Video Input

The "INPUT" button will step through each video source and antenna source input each time it is pressed. Use the audio and video inputs to connect external devices, such as VCR's, camcorders, laser disc players, video games, etc. If your device has only one audio output (mono sound), connect it to the left audio jack on the TV.

③ Audio to Hi-Fi

These jacks provide variable audio output to a separate stereo system amplifier. With this connection, the audio to the stereo can be controlled by the television's remote control.

④ S-Video

Input 1 provides S-Video (Super Video) jacks for connecting equipment with S-Video output capability.

The S-Video connection is provided for high performance laser discs, VCR's etc., that have this feature. Use this connection in place of the standard video connection if your device has this feature.

NOTE: Refer to the operating guide of your other electronic equipment for additional information on connecting your hookup cables.



REAR PANEL CONNECTIONS

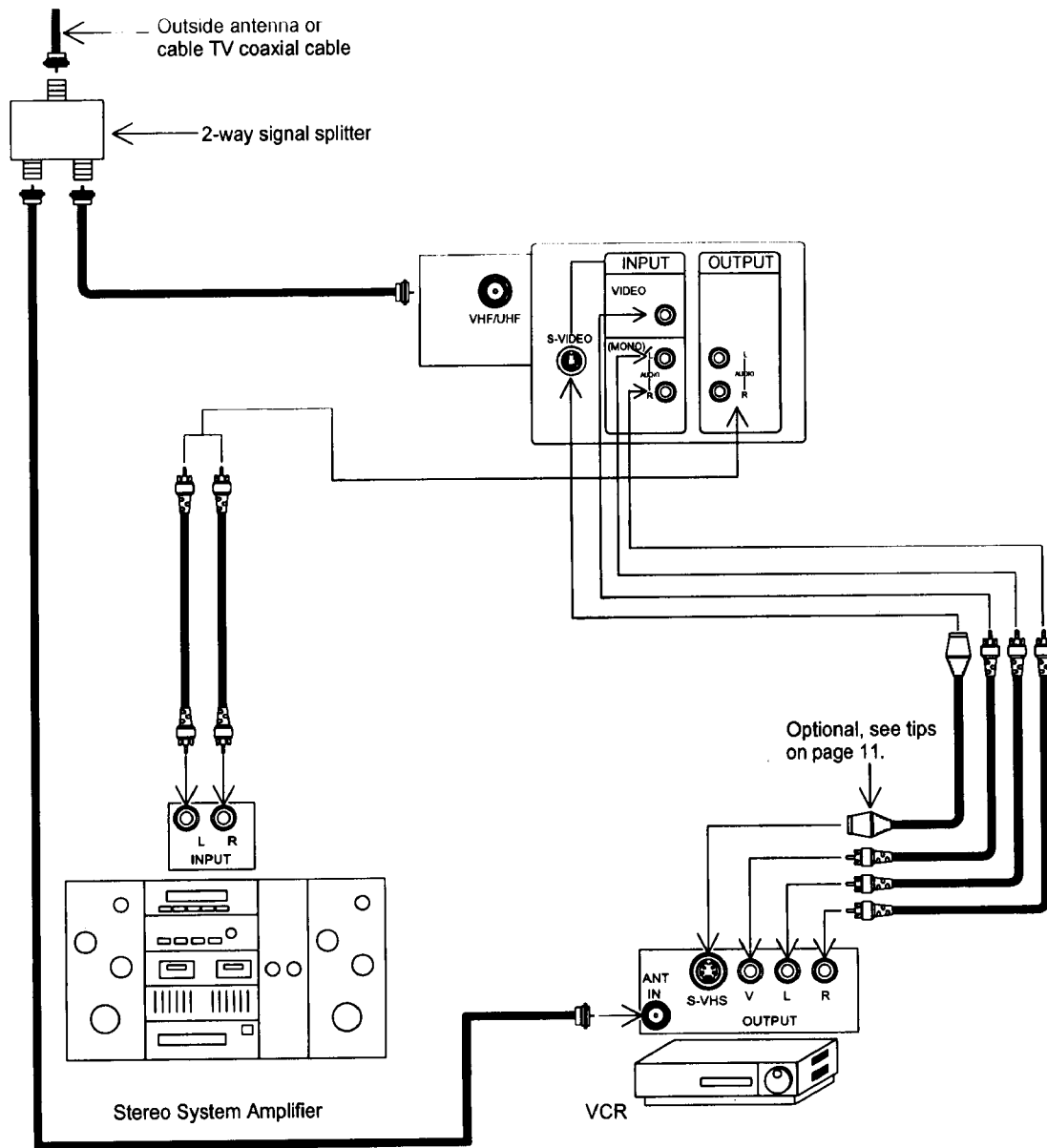

Typical full feature set-up. Follow connections that pertain to your personal entertainment system.

EXTERNAL CONNECTIONS



CONNECTING EXTERNAL AUDIO AMPLIFIER

To control the audio level of an external audio amplifier with the remote transmitter, connect the system as shown below in Fig. 1.

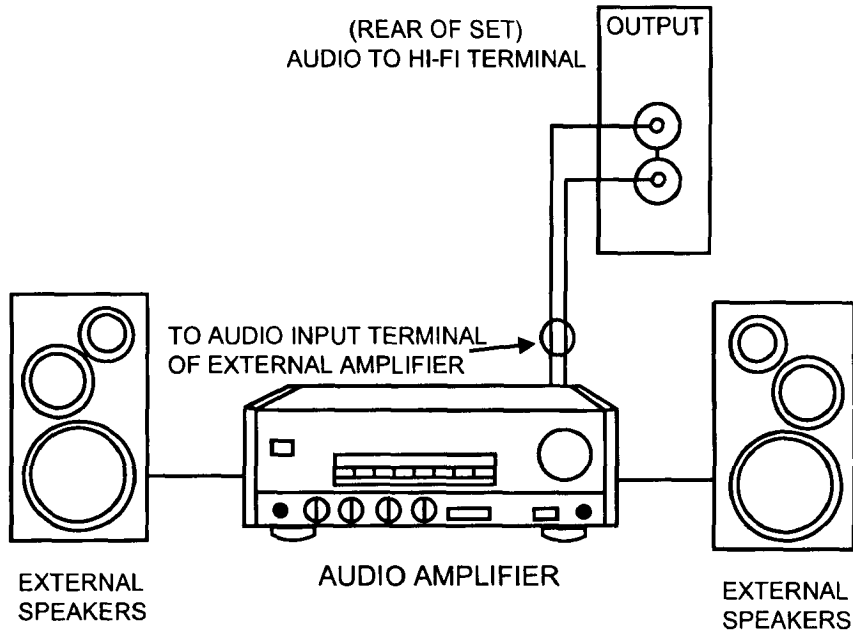

NOTE: To prevent damage to the speaker and distorted sound, set the volume control of the audio amplifier lower and adjust the sound using the remote transmitter of the TV set.



CONNECTING EXTERNAL VIDEO SOURCES

The exact arrangement you use to connect the Video Cassette Recorder, Video Disc Player and Video Camera to your TV set is dependent on the model and features of each component. Check the Owner's Manual of each component for the location of its video and audio inputs and outputs. The following connection diagrams are offered as suggestions. However, you may need to modify them to accommodate your particular assortment of components and features. For best performance, video and audio cables should be made from coaxial shielded wire.

Before Operating External Video Source

The input mode is changed every time the INPUT button is pressed as shown below. Connect external source to the INPUT terminal, then press the INPUT button as necessary to view the input source.

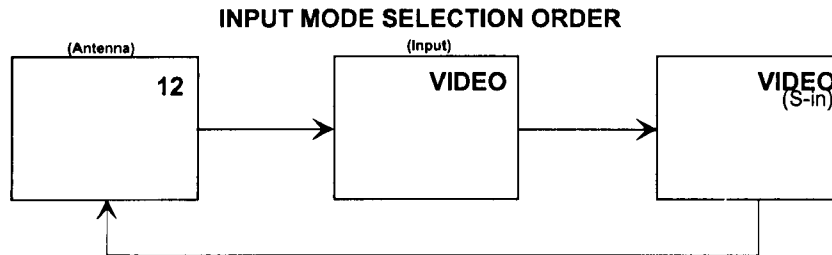

NOTE: When the TV is set to "VIDEO" and a video signal is not received from VIDEO INPUT JACK on the jack panel of the TV (i.e., VCR/Video Disc Player, etc. is not connected or the video device is OFF), the screen will be grey-blue.

CONNECTING MONAURAL AUDIO VCR OR VIDEO DISC PLAYER

1. Connect the cable from the VIDEO OUT of the VCR or the Video Disc Player to the INPUT (VIDEO) jack on the TV set. (Fig. 1)
2. Connect the cable from the AUDIO OUT of the VCR or the Video Disk Player to the INPUT (MONO)/L(AUDIO) jack.
3. Press the INPUT button to view the program from the VCR or Video Disc Player. The mode "VIDEO" disappears automatically after approximately 8 seconds.
4. Press the INPUT button to return to the previous channel.
5. See below.

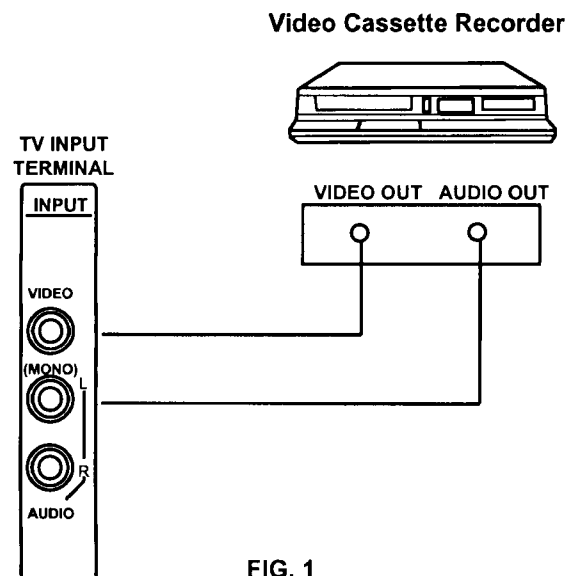

FIG. 1

CONNECTING EXTERNAL VIDEO SOURCES



CONNECTING STEREO VCR OR STEREO VIDEO DISC PLAYER

1. Connect the cable from the VIDEO OUT of the VCR or the Video Disc Player to the "INPUT (VIDEO)" jack on the TV set. (Fig. 1)
2. Connect the cable from the AUDIO OUT "R" of the VCR or the Video Disc Player to the "INPUT(AUDIO/R)" jack.
3. Connect the cable from the AUDIO OUT "L" of the VCR or the Video Disc Player to the "INPUT(AUDIO/L)" jack.
4. Press the INPUT button to view the program from the VCR or Video Disc Player. The mode "VIDEO" disappears automatically after approximately 8 seconds.
5. Press the INPUT button to return to the previous channel.

Video Cassette Recorder

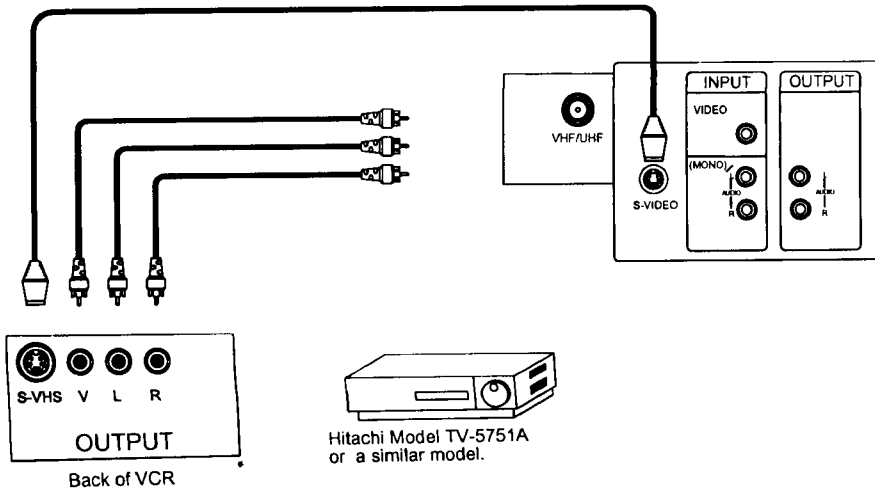
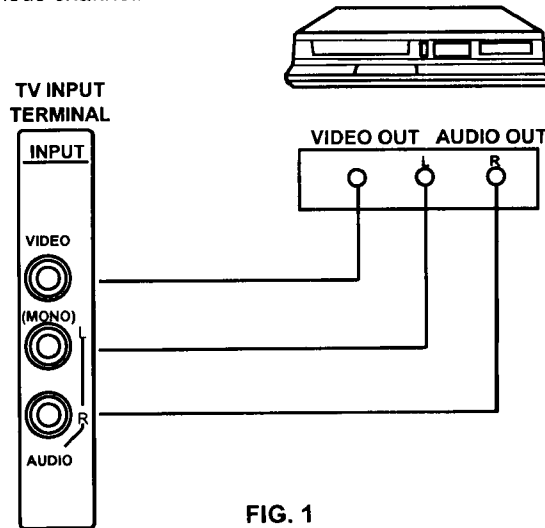

NOTE: Completely insert the connection cord plugs when connecting to REAR panel jacks. If you do not the picture that is played back will be abnormal.

If you have an S-VHS VCR, use the S-INPUT cable in place of the standard video cable.



THE REMOTE CONTROL (CLU-418U)

In addition to controlling all the functions on your HITACHI Color TV, the new remote is designed to operate different types of VCR's, CATV (Cable TV), and satellite converters with one touch. Basic operation keys are grouped together in one area.

To operate your TV, point the remote at the remote sensor of the TV and press the TV button on the remote. The remote will now control your TV.

To operate your VCR, point the remote at the remote sensor of the VCR and press the VCR button. The remote will now control your VCR. (See page 25 for instructions on how to program the remote to control your VCR.)

To operate your cable/satellite box, point the remote at the remote sensor of the cable/satellite box and press the CABLE button. The remote will now control your cable/satellite box. (See page 27 for instructions on how to program the remote to control your cable/satellite box.)

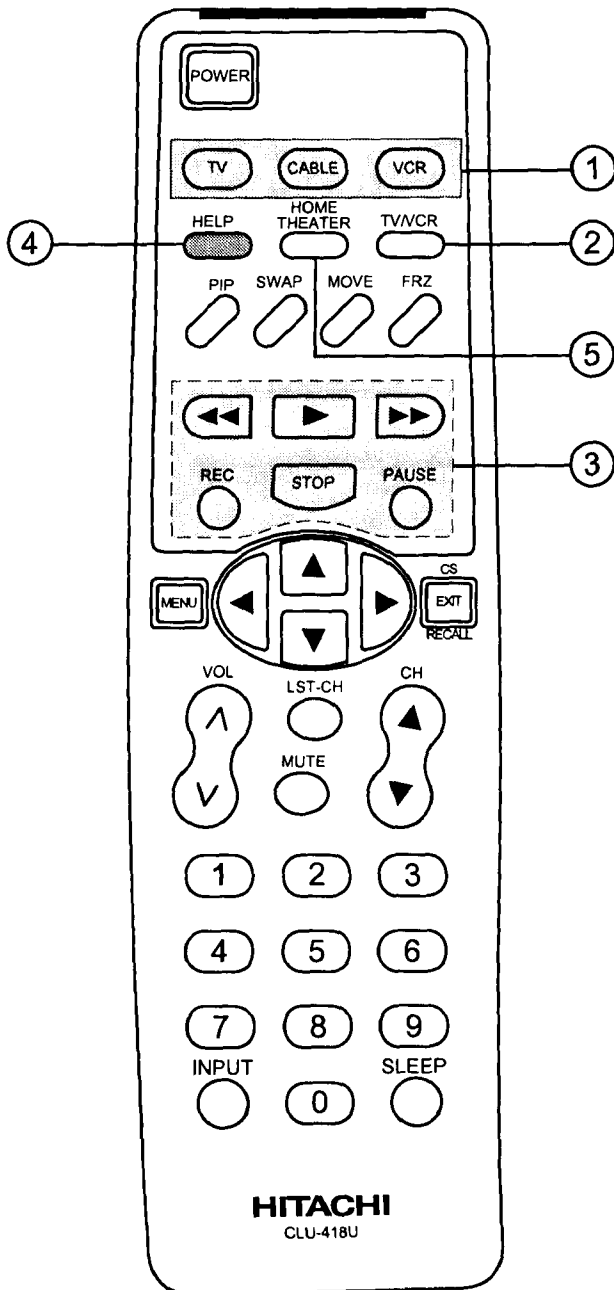

1 These buttons allow the remote to control your TV, VCR, or cable/satellite box depending on which mode is chosen, as explained above.

2 TV/VCR Button
When the remote is in the TV or VCR mode, this is the TV/VCR button. When the remote is in the CABLE/SATELLITE mode, this is the A/B button.

3 PRECODED VCR Buttons
These buttons always transmit the chosen pre-coded VCR codes.

4 HELP Button
Press HELP if help is needed to change menu settings.

5 HOME THEATER Button
The HOME THEATER button of the remote control CLU-418U does not respond when pressed for model 27CX7B because this model does not have HOME THEATER features.

THE REMOTE CONTROL (CLU-419UI)



In addition to controlling all the functions on your HITACHI Color TV, the new remote is designed to operate different types of VCR's, CATV (Cable TV), and satellite converters with one touch. Basic operation keys are grouped together in one area.

To operate your TV, point the remote at the remote sensor of the TV and press the TV button on the remote. The remote will now control your TV.

To operate your VCR, point the remote at the remote sensor of the VCR and press the VCR button. The remote will now control your VCR. (See page 25 for instructions on how to program the remote to control your VCR.)

To operate your cable/satellite box, point the remote at the remote sensor of the cable/satellite box and press the CABLE button. The remote will now control your cable/satellite box. (See page 27 for instructions on how to program the remote to control your cable/satellite box.)

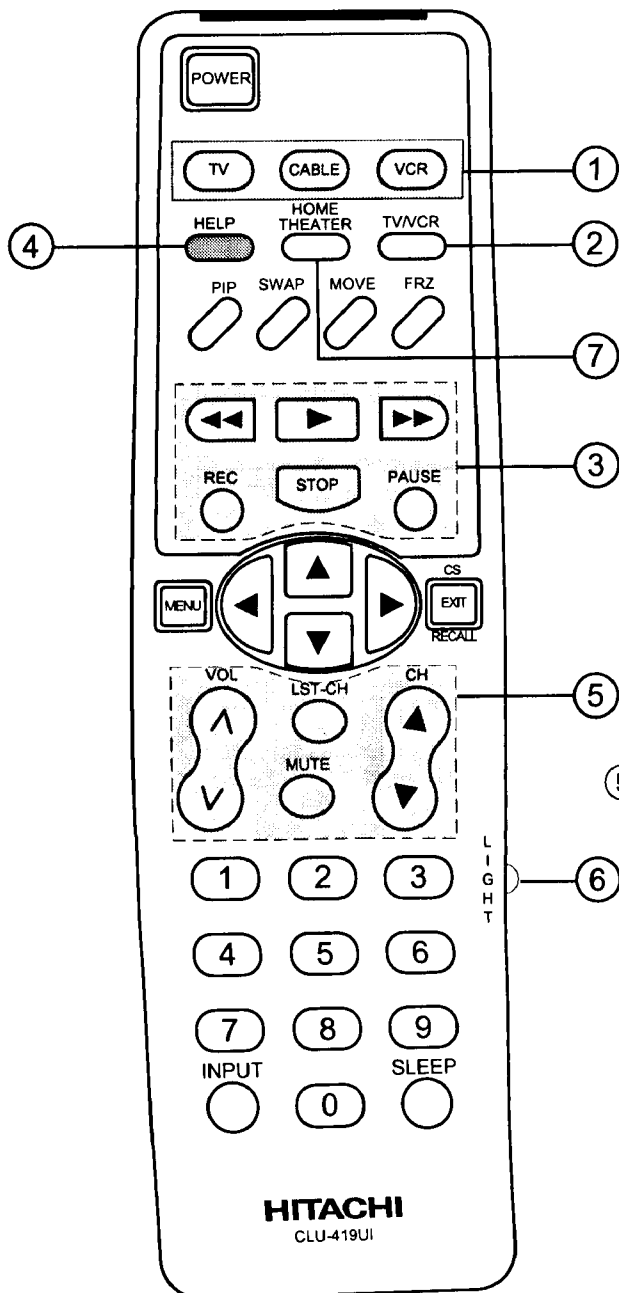

1 These buttons allow the remote to control your TV, VCR, or cable/satellite box depending on which mode is chosen, as explained above.

2 TV/VCR Button
When the remote is in the TV or VCR mode, this is the TV/VCR button. When the remote is in the CABLE/SATELLITE mode, this is the A/B button.

3 PRECODED VCR Buttons
These buttons always transmit the chosen pre-coded VCR codes.

4 HELP Button
Press HELP if help is needed to change menu settings.

5, 6 LIGHT Button
When you are in a dark room, press this button on the side of the remote to light up the buttons shown in **5**. The light will stay on for about 8 seconds if the light button is not pressed again. These buttons will not appear to light if the room is too bright.

7 HOME THEATER Button
The HOME THEATER button of the remote control CLU-419UI does not respond when pressed for model 27CX75B because this model does not have HOME THEATER features.



HOW TO USE THE REMOTE TO CONTROL YOUR TV

A detailed explanation of the circled numbers is on the following pages. (example: ①)

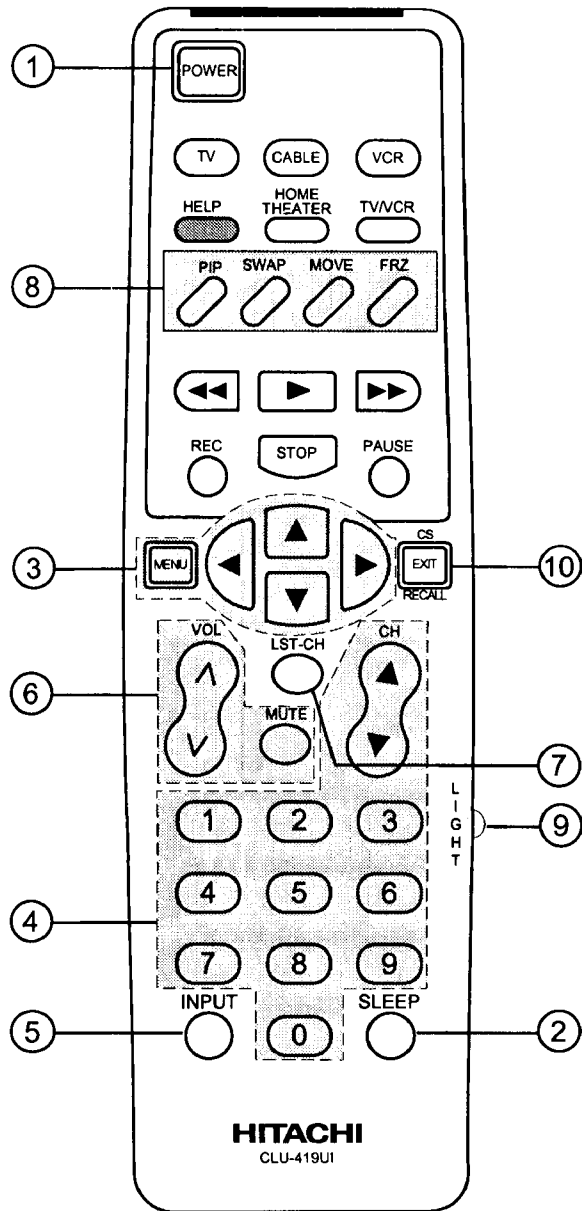
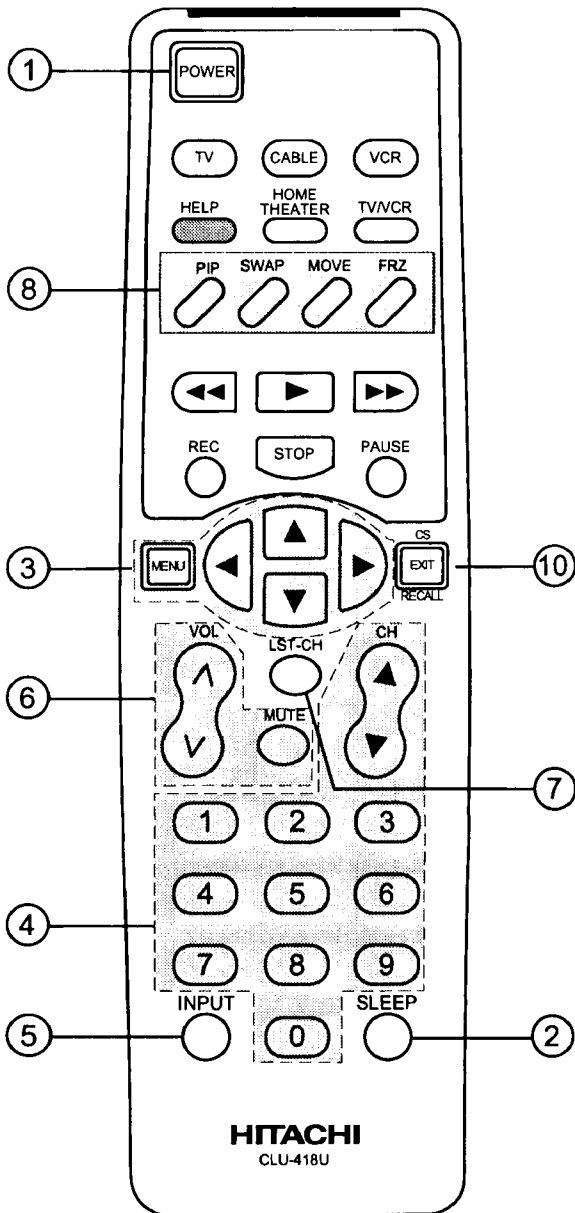

HOW TO USE THE REMOTE TO CONTROL YOUR TV



1 TV POWER Button

Press this button to turn the TV set on or off. If a message is set, it will be displayed when the TV is first turned on. (See page 44.)

2 SLEEP Button

Press this button to display the SLEEP TIMER in the lower left corner of the screen. Every subsequent press of this button will add 15 minutes to the timer, up to a maximum of 3 hours.

3 MENU, CURSOR

All the On-Screen Display features can be set or adjusted by using these buttons.

The "MENU" button will start the On-Screen Display.

The "CURSOR" buttons will highlight functions or adjust and set different features. Pressing the cursor button will also give you access to the FAMILY FAVORITES CHANNELS on-screen display.

4 CHANNEL SELECTOR Buttons

Enter two or three numbers to select channels. Enter "0" first for channels 1 to 9. For channels 100 and above, press the 1 button and wait for 2 seconds before pressing the last two digits of the channel.

Channel selection may also be performed by pressing CH up (▲) or down (▼).

You may also use these buttons for channel scanning. Press and hold the CH up (▲) or down (▼) button and the TV will start quickly scanning through the channels. Release the CH up (▲) or down (▼) button when the TV scans to the channel you wish to watch and the TV will tune to that channel.

NOTE: The TV may not receive some channels if you are not in the correct SIGNAL SOURCE mode. (See page 32.)

5 INPUT Button

The INPUT button will select between the antenna signal and the video input jacks each time the button is pressed. If the Picture-in-Picture (PiP) is on, the INPUT will not select any source signal on the main picture. However, if the PiP is on, the INPUT will alternate between the main signal source and the input source on the sub-picture. (See graphic below.)

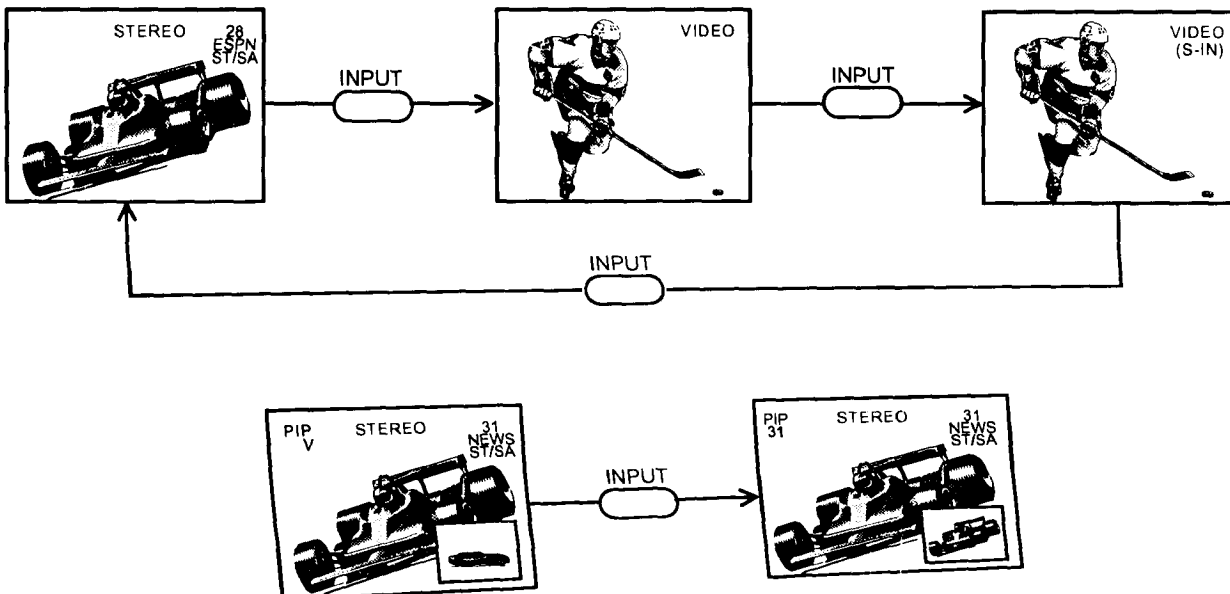



HOW TO USE THE REMOTE TO CONTROL YOUR TV

6 VOLUME, MUTE Buttons

Press the "VOLUME" up (▲) or down (▼) button until you obtain the desired sound level.

To turn the sound off instantly to answer the telephone, etc., press the "MUTE" button. Press the "MUTE" button again or press the "VOLUME" up (▲) button to restore the sound.

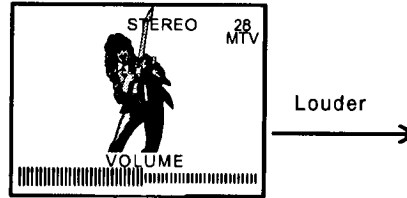

The word "MUTE" will remain displayed if the CLOSED CAPTION feature is turned off.

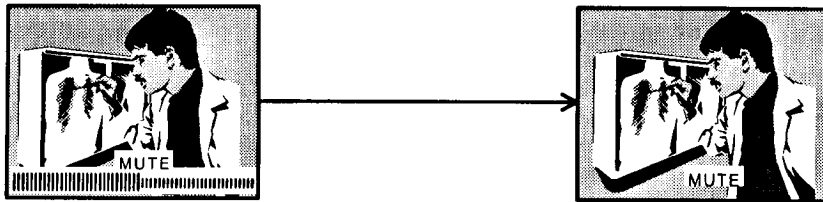

The word "MUTE" will not be displayed if the CLOSED CAPTION feature is on.



7 LAST CHANNEL (LST-CH) button

Use this button to select between the last two channels viewed. (Good for watching two sporting events, etc.)

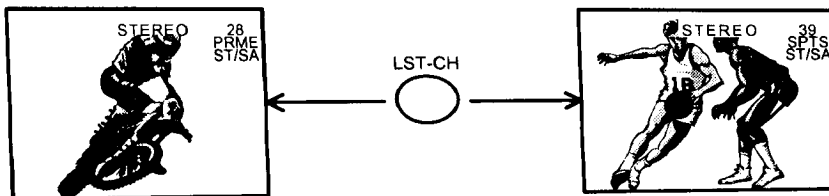

8 PICTURE-IN-PICTURE

See separate section on page 22 for a description.

HOW TO USE THE REMOTE TO CONTROL YOUR TV



9 LIGHT CHANNEL (CLU-418U does not have a light button.)

When you are in a dark room, press this button to light up the volume and channel buttons. The light will stay on for about 8 seconds if no buttons are pressed. The buttons will not appear to light if the room is too bright.

10 EXIT/RECALL/COMMERCIAL SKIP Button

Press this button when no menu is displayed when you want to check the channel being received, or if it has stereo (ST) or second audio (SAP).

You can also check the time, CHANNEL ID, and if the SLEEP TIME has been set.

When in MENU mode, this button will exit all On Screen Displays.

Press this button twice quickly, when no menu is displayed, to enable the COMMERCIAL SKIP (CS) function. This will tune the TV to the last channel viewed and after 30 seconds, tune back to the original channel.

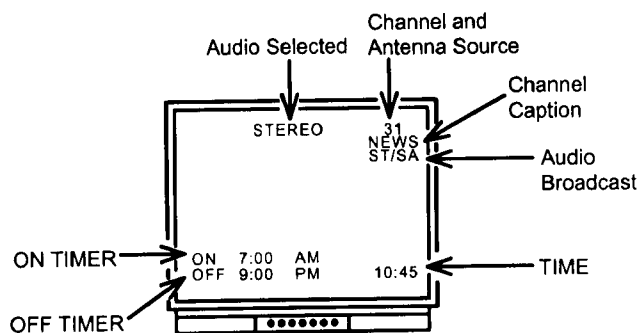

If a video input is used:

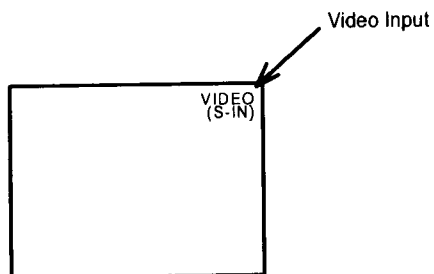

You can also use the RECALL button to quickly clear many of the other on-screen displays



PICTURE-IN-PICTURE

The Picture-in-Picture feature is convenient when you want to watch more than one program at the same time. You can watch a TV program while viewing a VCR program (TV or tape) on the video inputs.

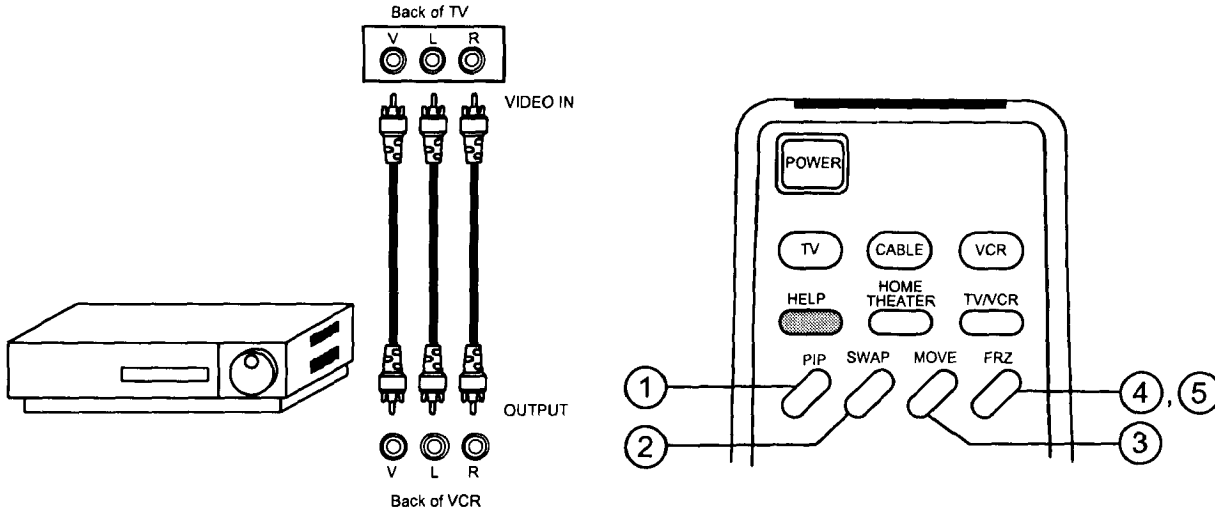

1 P-IN-P Button

Press the "PIP" button and a sub-picture appears in one corner of the screen. Press the button a second time to remove the sub-picture from the screen. The TV channel will always be either the main picture or the sub-picture.

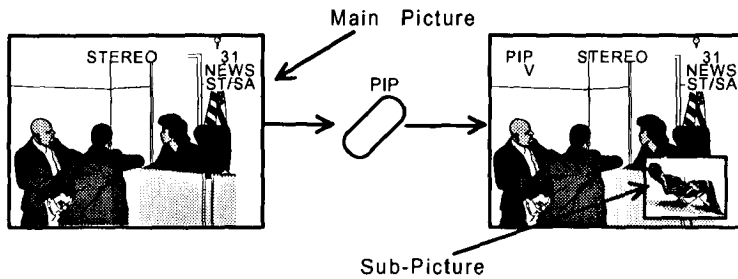

2 SWAP Button

If you wish to switch what is being shown on the main picture to the sub-picture, press the "SWAP" button.

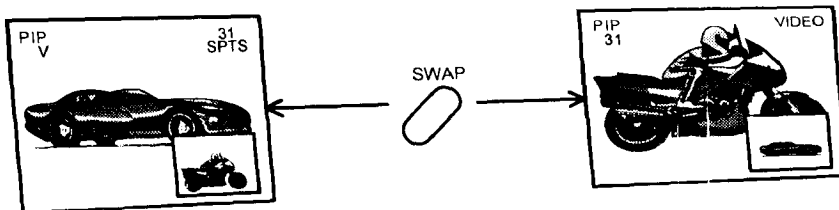

PICTURE-IN-PICTURE



③ MOVE Button

To move the sub-picture to another corner, press the "MOVE" button twice quickly. The sub-picture moves one step counterclockwise every time the "MOVE" button is pressed twice. To move the sub-picture to any location of the screen, press the "MOVE" button once and quickly press the CURSOR buttons.

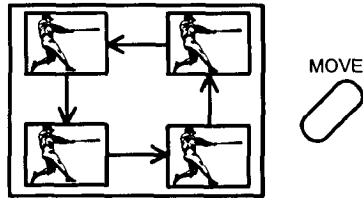

④ FREEZE (FRZ) Button

If you wish to freeze the sub-picture, press the "FRZ" button. This is convenient when trying to write down the address for a mail order company, recording statistics for a sporting event, etc. To return the picture to motion, press the button again.

⑤ FREEZE (FRZ) Button (without a sub-picture (PIP OFF))

Press this button without a sub-picture to freeze the picture you are currently viewing. Press this button again to return to normal viewing. The SWAP button will not work with this FREEZE function.

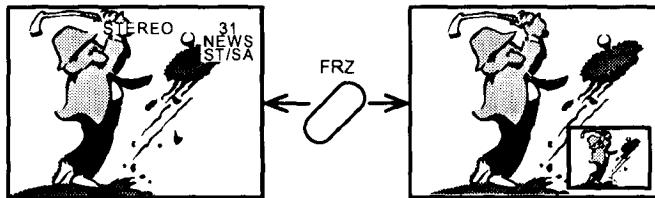

CAUTION: A pattern burn may develop if the sub-picture is left in the same corner permanently. If the PIP feature is used frequently, occasionally move the sub-picture to a different corner.

NOTE:

1. Only sound from the main picture can be heard.
2. P-IN-P will not work with a CHILD LOCK channel as the main picture but will be displayed as a sub-picture.
3. Each freeze frame is delayed about 0.1 (1/10) second.
4. When the "PIP" button is pressed, the sub-picture will appear in the same position as previously set.



USING THE REMOTE TO CONTROL VCR FUNCTIONS

A detailed explanation of the circled numbers is on the following pages. (example: ①)

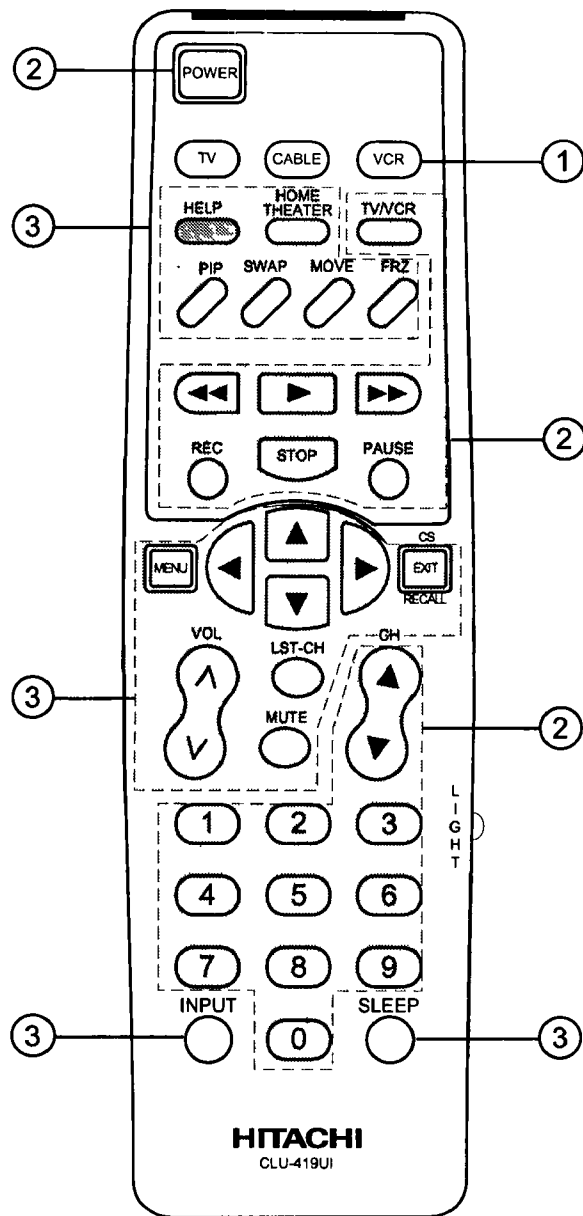
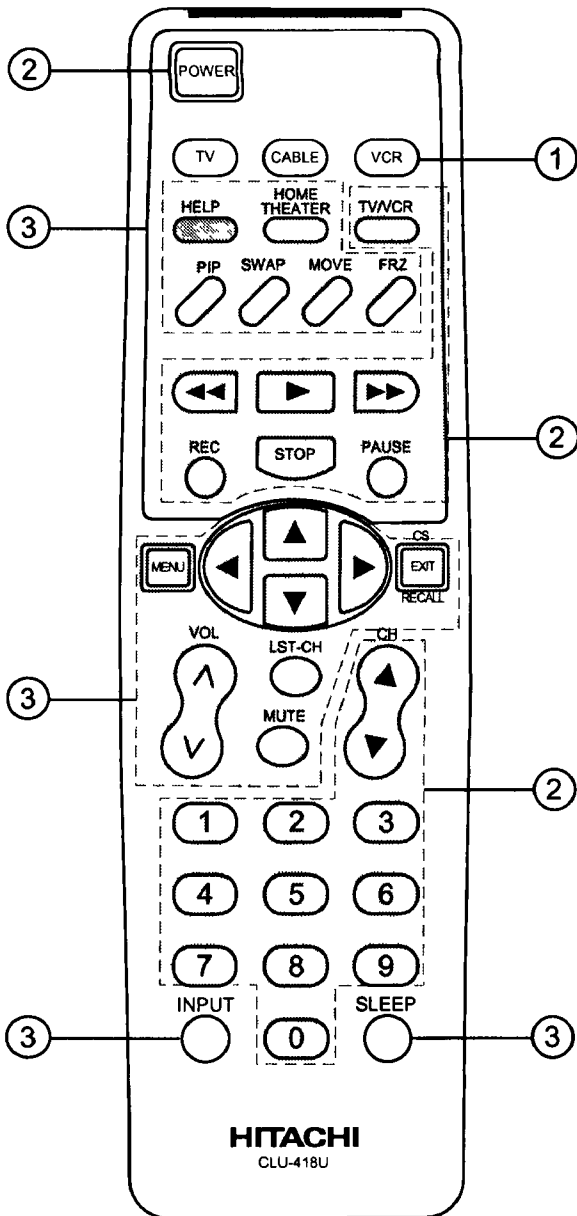

USING THE REMOTE TO CONTROL VCR FUNCTIONS



Operating the pre-coded function for your VCR

This remote is designed to operate different types of VCR's. You must first program the remote to match the remote system of your VCR. (Refer to page 28.)

1. Turn on your VCR.
2. Aim the remote control at the front of your VCR.
3. Press the VCR button to switch to the VCR pre-coded mode.
4. While holding down the VCR button on the remote, enter the 2 digit preset code that matches your VCR as shown on page 28. The remote will turn off your VCR when the correct 2 digit preset code is entered. When this occurs, the remote control is programmed for your VCR. If the VCR does not turn off after 5 seconds, try a different 2 digit preset code.
5. The remote will now control your VCR.

NOTES:

1. If your VCR cannot be operated after performing the above procedures, this means that your VCR code has not been precoded into the remote.
2. In the unlikely event that your VCR cannot be operated after performing the above procedures, please consult your VCR operating guide.
3. The remote control will remember the codes you have programmed in until the batteries are removed from the remote control. After replacing the batteries repeat the entire programming procedure stated above.
4. If your VCR does not have a power function, the remote will issue the CHANNEL UP function.

① VCR Button

This allows the remote to control your VCR by setting it to VCR mode.

② PRECODED VCR buttons

These buttons transmit the chosen precoded VCR codes. For some VCR's, you must press the RECORD button twice to record a program.

③ EXCLUSIVE TV buttons

These buttons are for operating the TV.

NOTE: 1. Refer to the instruction manual of the VCR for operation of the buttons exclusively for the VCR.



USING THE REMOTE TO CONTROL CABLE/SATELLITE BOX FUNCTIONS

A detailed explanation of the circled numbers is on the following pages. (example: ①)

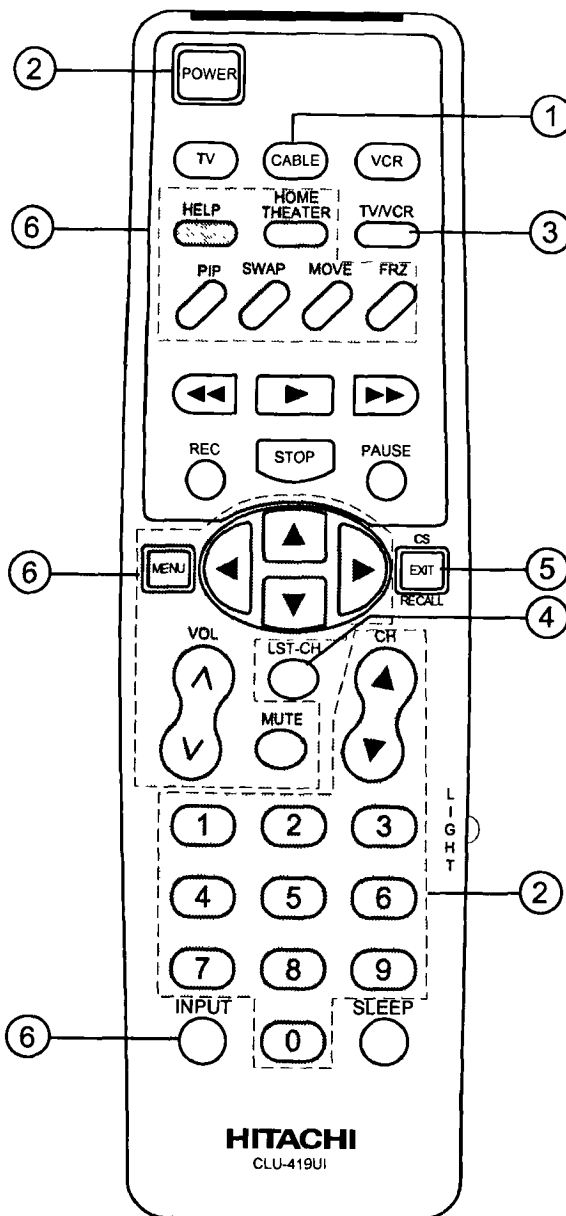
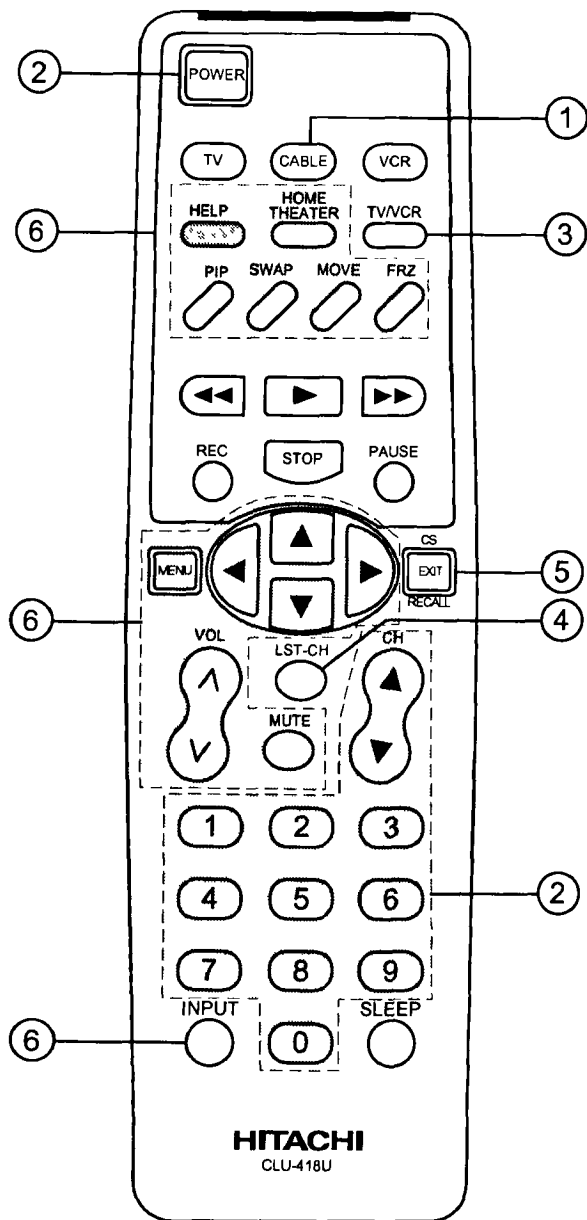

USING THE REMOTE TO CONTROL CABLE/SATELLITE BOX FUNCTIONS



Operating the pre-coded function for your cable/satellite box.

This remote is designed to operate different types of cable boxes and Digital Satellite Systems. You must first program the remote to match the remote system in your cable/satellite box. (Refer to page 28.)

1. Turn on your cable/satellite box.
2. Aim the remote control at the front of your cable/satellite box.
3. Press the CABLE button to switch to cable/satellite box mode.
4. While holding down the CABLE button, enter the 2 digit preset code that matches your cable/satellite box as shown on page 28. The remote will turn off your cable/satellite box when the correct 2 digit preset code is entered. When this occurs, the remote control is programmed for your cable/satellite box. If the cable/satellite box does not turn off after 5 seconds, try another 2 digit preset code.
5. The remote will now control your cable/satellite box.

NOTES:

1. If your cable/satellite box cannot be operated after performing the above procedures, this means that your cable/satellite box code has not been precoded into the remote.
2. In the unlikely event that your cable/satellite box cannot be operated after performing the above procedures, please consult your cable/satellite box operating guide.
3. The remote control will remember the codes you have programmed in until the batteries are removed from the remote control. After replacing the batteries, repeat the entire programming procedure stated above.
4. If your cable/satellite box does not have a power function, the remote will issue the CHANNEL UP function.

① CABLE Button

This button allows the remote to control your cable/satellite box by setting it to CABLE/SATELLITE mode.

② PRECODED CABLE/SATELLITE BOX Buttons

These buttons transmit the chosen precoded CATV and satellite codes.

③ TV/VCR Button

When the remote is in CABLE/SATELLITE mode, this is the A/B button.

④ LST-CH Button

If your cable/satellite box has an enter function, this button will send the cable/satellite box enter code.

⑤ CS/EXIT/RECALL Button

If your cable/satellite box does not have a last channel function, this button will send the TV channel recall code.

⑥ EXCLUSIVE TV Buttons

These buttons are for operating the TV.



CABLE/SATELLITE AND VCR CODES

CABLE BRAND	CODES	SATELLITE BRAND	CODES	VCR BRAND (Cont.)	CODES
ABC	.01, 03, 05, 06, 09, 11, 12, 14, 30	General Instrument	.61	MEI	.09
Antronix	.44	Jerrold	.61, 62	Memorex	.00, 09, 10, 12, 18, 19, 20, 30, 48
Archer	.28, 40, 44	Primestar	.61, 62	MGA	.16, 23
Belcor	.31	RCA	.60	MGN Technology	.48
Cable Star	.31	Sony	.63	Minolta	.15, 31
Century	.40			Mitsubishi	.16, 23, 26, 36, 49
Citizen	.40	TELEVISION BRAND	CODES	Motorola	.09, 20
Colour Voice	.19, 25	Hitachi	.00	MTC	.00, 48
Comtronics	.29, 34	Megatron	.00	Multitech	.00, 27
Contec	.15			NEC	.11, 13, 14, 26, 30
Dae Ryung	.06			Nikko	.10
Eastern	.02	VCR BRAND	CODES	Noblex	.48
Electricord	.37	Adventura	.00	Olympus	.09, 47
Everquest	.13	Aiko	.50	Optimus	.10, 20, 30
Focus	.57	Aiwa	.00	Orion	.51
Garrard	.40	Akai	.14, 23, 49	Panasonic	.09, 35, 46, 47, 53
GC Electronics	.31, 44	American High	.09	Penney	.09, 10, 11, 13, 15, 21, 48
Gemini	.13, 32, 36, 46	Asha	.48	Pentax	.15, 24, 31
General Instrument	.09, 51	Audiovox	.10	Philco	.09
GoldStar	.29, 39	Beaumarck	.48	Phillips	.09, 28, 32
Hamlin	.08, 16, 27, 49, 50	Bell & Howell	.30	Pilot	.10
Hitachi	.09	Brandt	.38	Pioneer	.26
Hytex	.05	Broksonic	.33, 37, 43, 51, 52	Portland	.05
Jasco	.40	Calix	.10	Protac	.27
Jerrold	.03, 09, 10, 12, 13, 30, 51	Canon	.09	Pulsar	.12
Macom	.26	Capehart	.05	Quarter	.18
Magnavox	.21	Carver	.28	Quartz	.18
Memorex	.00	CCE	.27, 50	Quasar	.09
Movie Time	.35, 37, 42	Citizen	.10, 50	Radio Shack	.00, 10
NSC	.35, 37, 42	Colt	.27	Radix	.10
Oak	.05, 15, 47	Craig	.10, 19, 27, 48	Randex	.10
Panasonic	.00, 17, 38	Curtis Mathes	.09, 14, 22	RCA	.15, 22, 24, 31, 34, 39
Paragon	.00	Cybernex	.48	Realistic	.00, 09, 10, 18, 19, 20, 25, 30, 48
Philips	.19, 21, 22, 23, 24, 25, 40, 46, 54	Daewoo	.03, 05, 17, 29, 50	Ricoh	.08
Pioneer	.18, 39, 65	Daytron	.05	Runco	.12
Popular Mechanics	.57	Dynatech	.00	Samsung	.17, 48
Pulsar	.00	Electrohome	.10	Sanky	.12, 20
RCA	.17	Electrohome	.10	Sansui	.14, 26
Realistic	.44	Emerex	.06	Sanyo	.18, 19, 30, 48
Recoton	.57	Emerson	.00, 01, 10, 16, 23, 33, 37, 40, 41, 43, 44, 50, 51, 52	Scott	.16, 17, 33, 37, 43, 44
Regal	.16, 49, 50, 53	Fisher	.19, 21, 25, 30	Sears	.09, 10, 15, 18, 19, 21, 25, 30, 31
Regency	.02	Fuji	.07, 09	Sharp	.20
Rembrandt	.09, 36	Funai	.00	Shintom	.27
Runco	.00	Garrard	.00	Shogun	.48
Samsung	.29, 39	GE	.09, 22, 24, 39	Singer	.27
Scientific Atlanta	.04, 06, 14, 52	Goldstar	.04, 10, 11	Sony	.06, 07, 08, 09
Signal	.13, 29	Gradiente	.00	STS	.15
Signature	.09	Harley Davidson	.00	Sylvania	.00, 09, 16, 28, 32
SL Marx	.29	Harman/Kardon	.11	Symphonic	.00
Sprucer	.17, 55	Harwood	.27	Tatung	.14
Starcom	.03, 13, 30	Headquarter	.18	Teac	.00, 14
Stargate	.13, 29	HI-Q	.19	Technics	.09, 35
Starquest	.13	Hitachi	.14, 15, 24, 31	Teknika	.00, 09, 10
StarSight	.58, 59	Jensen	.14	Telefunken	.38
Sylvania	.01	JVC	.02, 14, 26	TMK	.40, 48
Teleview	.29	KEC	.10, 50	Toshiba	.16, 17, 25, 44
Texscan	.01	Kenwood	.11, 14, 26	Totevision	.10, 48
Tocom	.10, 11, 33	KLH	.27	Unitech	.48
Toshiba	.00	Kodak	.9, 10	Vector	.17
Tusa	.13	Lloyd	.00	Vector Research	.11, 13
TV86	.35	Lloyd's	.40	Video Concepts	.13, 17, 23
Unika	.40, 44	Logik	.27	Videosonic	.48
United Artists	.05	LXI	.10	Wards	.00, 09, 15, 19, 20, 22, 27, 34, 44, 48
United Cable	.03	Magnovox	.09, 12, 28, 32, 34	XR-1000	.00, 09, 27
Universal	.28, 31, 37, 40, 43, 44	Magnin	.48	Yamaha	.11
Videoway	.48	Marantz	.09, 28	Zenith	.07, 08, 12
Viewstar	.21, 34, 35, 45	Marta	.10		
Zenith	.00, 64	Matsushita	.09		
Zentek	.57				

COLOR GRAPHIC GUIDE



1. Press MENU on the remote control to display the different features on your HITACHI TV.
2. Press the CURSOR buttons to highlight and select different features.
3. Press EXIT on the remote control to quickly exit from a menu.
4. Press HELP on the remote control when a menu is displayed, and text will appear giving a description of that menu.

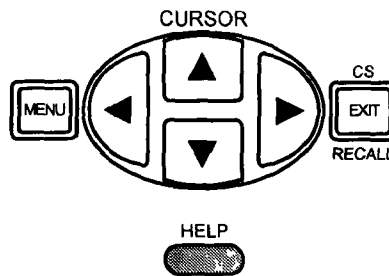

This part of the screen shows what selections are available.



This part of the screen shows which remote control buttons to use.

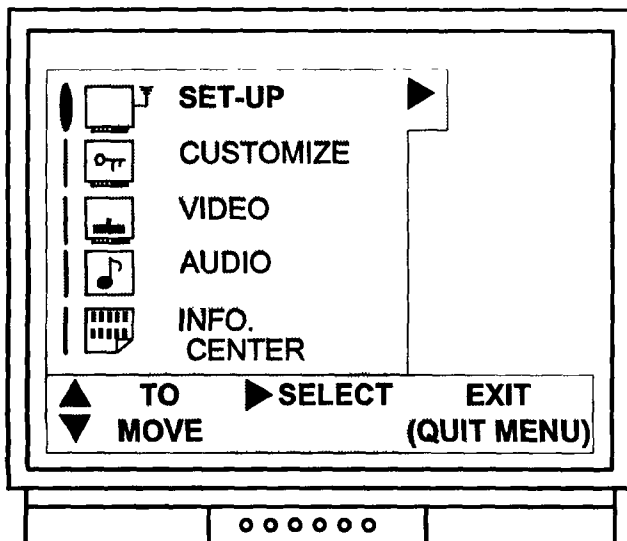

AUTOMATIC DEMONSTRATION

This feature will demonstrate how to use and set up your HITACHI television. To perform this feature, press the front panel POWER button and hold for 5 seconds. The On-Screen Display will appear on your TV set demonstrating the settings of your TV feature.

To exit AUTOMATIC DEMONSTRATION, press the power button on the front panel of the TV, which will turn the TV off. Press the power button again to turn your TV set on and resume normal operation.

NOTE: On some televisions, the "SHIFT" and "EXCHNG" that appear during the Automatic Demonstration are equivalent to the "MOVE" and "SWAP" button respectively on your remote control. The word "WEEK" that appears in the help menu under AUDIO-ADVANCE SETTINGS should be "WEAK".



COLOR GRAPHIC GUIDE



MENU LANGUAGE
SIGNAL SOURCE
AUTO CHANNEL SET
CHANNEL ADD/DEL
CHANNEL LIST
CLOCK SET

Choose English, French, or Spanish language.
 Select Antenna or CableTV.
 First time set up for channel buttons.
 Add or delete channel.
 Check channel name, scan, and child lock.
 Set before using timer features.



CHANNEL ID
FAMILY FAVORITES
CHILD LOCK OPTIONS
ON/OFF TIMER
CLOSED CAPTION

Label channels PAY1, ABC, etc.
 Store a family's favorite channels.
 Block channel picture & sound.
 Turn TV on and off once, daily, or weekly.
 Feature to display dialogue/text.



CONTRAST
BRIGHTNESS
COLOR
TINT
SHARPNESS
COLOR TEMP.
RESET

Adjust contrast.
 Adjust brightness.
 Adjust color.
 Adjust tint.
 Adjust sharpness.
 Select warm (red tones) or cool (blue tones).
 Set VIDEO to factory preset condition.



BASS
TREBLE
BALANCE
RESET
ADVANCE SETTINGS
VOLUME CORRECTION

Adjust bass.
 Adjust treble.
 Adjust balance.
 Set AUDIO to factory preset condition.
 Improve sound performance.
 Adjust volume.



PERSONAL MESSAGE

Used to leave message for daily reminder.



SET-UP



Select SET-UP when setting your TV up for the first time. Use the CURSOR ▲,▼ buttons on the remote to highlight the function desired.

MENU LANGUAGE

This feature will allow you to select any one of 3 different languages for all on screen displays.

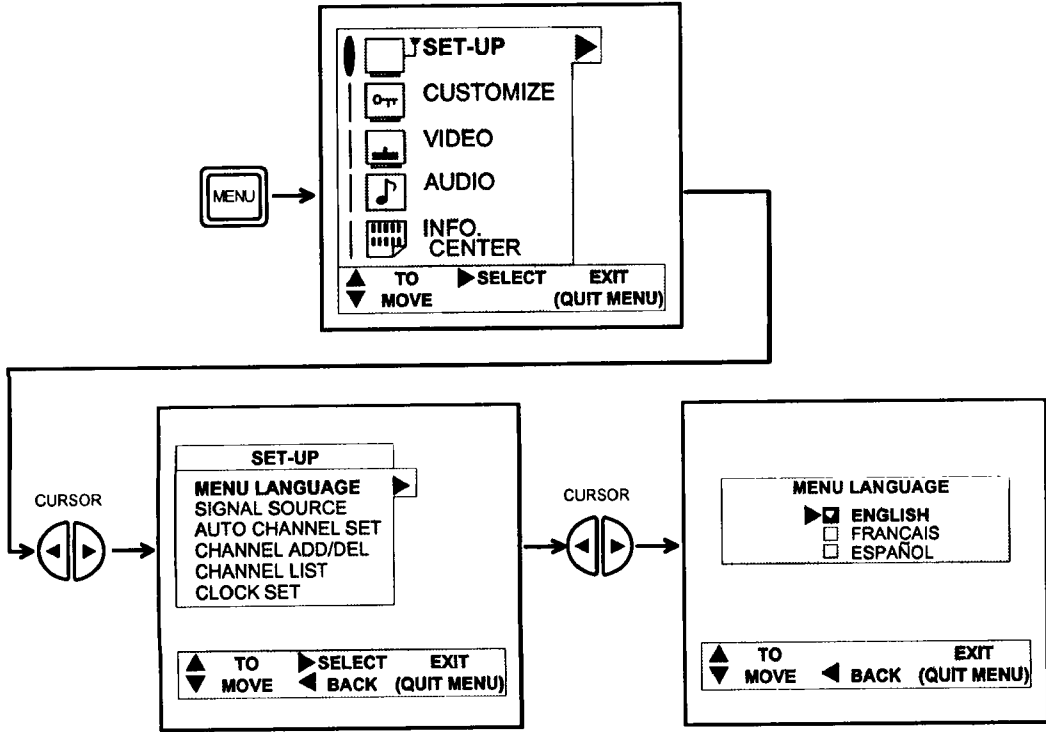

Use CURSOR ▲ or ▼ to select the MENU LANGUAGE of your choice.

Press MENU/EXIT to quit menu or CURSOR ◀ to return to previous menu.



SET-UP

SIGNAL SOURCE

Select ANTENNA if you are using an indoor or outdoor antenna. Select CATV if you have cable TV.

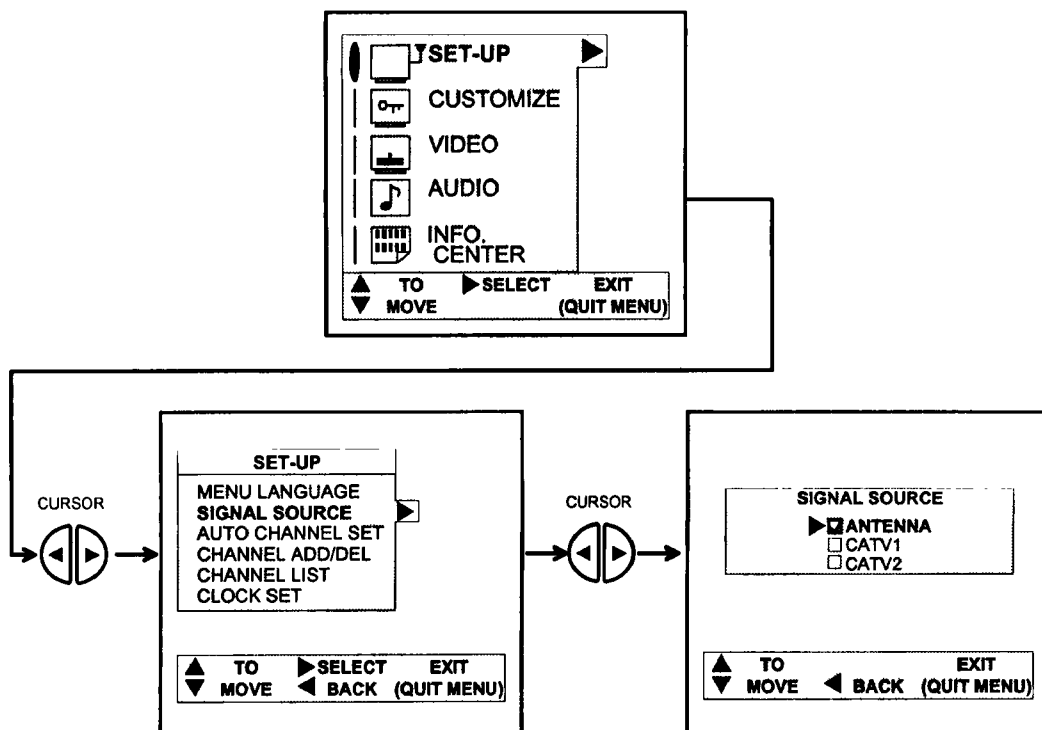

Press CURSOR ▲ or ▼ to highlight and select the correct SIGNAL SOURCE mode.
Press MENU/EXIT to quit MENU or CURSOR ◀ to return to previous menu.

RECEPTION BAND		
ANTENNA	CATV 1 OR CATV 2	
	CATV CHANNEL	Indicated on the screen
VHF 2 ~ 13ch UHF 14 ~ 69ch	VHF 2 ~ 13	2 ~ 13
	Mid band A ~ I	14 ~ 22
	A-5 ~ A-1	95 ~ 99
	Super Band J ~ W	23 ~ 36
	Hyper band	37 ~ 64
	W + 1 ~ W + 28	
	Ultra band	65 ~ 125
	W + 29 ~ W + 84	

Reception channels for each mode are shown at the left.

Refer to your cable or TV guide for channel identification standards.

If certain CATV channels are poor or not possible in CATV1 mode, set SIGNAL SOURCE to CATV2.

SET-UP



AUTO CHANNEL SET

This feature will automatically store active TV channels in CHANNEL ADD/DEL. This will allow you to skip over unused channels when using the CHANNEL UP (▲) or DOWN (▼) buttons.

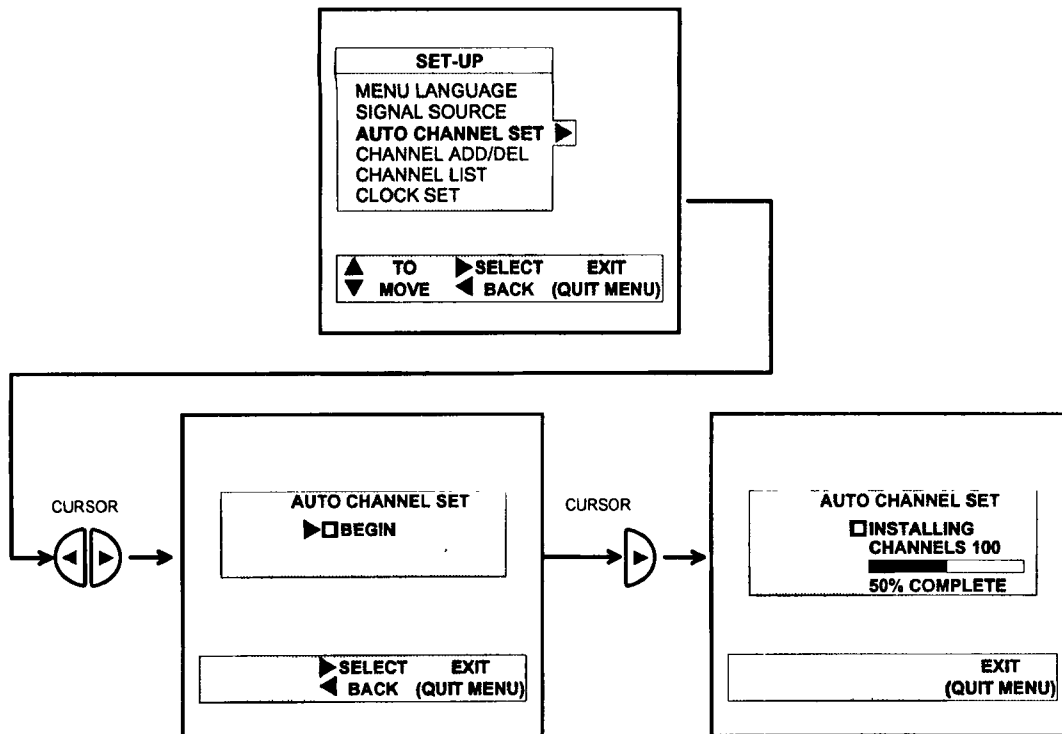

If the MENU/EXIT button is pressed while the AUTO CHANNEL SET function is engaged, programming will stop. See CHANNEL MEMORY to add or erase additional channels.

CHANNEL ADD/DEL

Use this function after AUTO CHANNEL SET to add or erase additional channels to the remote control CHANNEL ▲ or ▼ buttons.

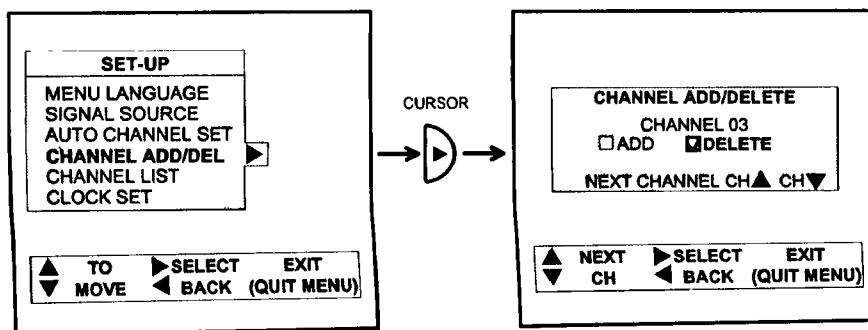

Add or erase additional channels while still in CHANNEL ADD/DEL using CURSOR ▲ or ▼, CHANNEL ▲ or ▼, and number buttons and then add or erase using the CURSOR ▶ button.

Press MENU/EXIT to quit menu or CURSOR ◀ to return to previous menu.



CHANNEL LIST

This function allows you to review which channels are labeled in CHANNEL CAPTION (NAME), which have been added to CHANNEL ADD/DEL (SCAN), and which are protected by CHILD LOCK (LOCK).

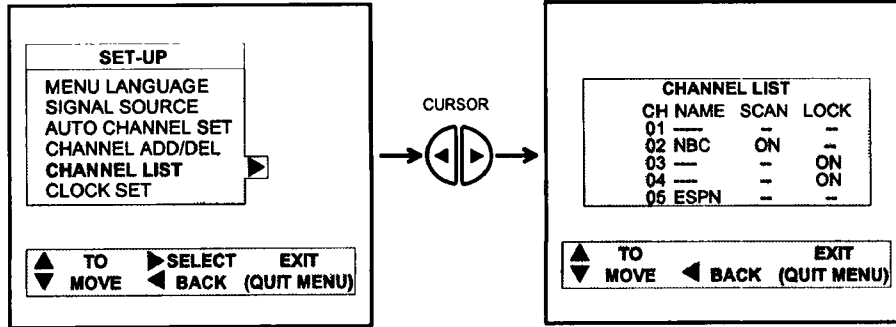

Press CURSOR ▲ or ▼ to review more channels.
Press MENU/EXIT to quit menu or CURSOR ◀ to return to previous menu.

CLOCK SET

Use this feature for all time related functions. The time must be set before you can use the ON/OFF TIMER or PERSONAL MESSAGE.

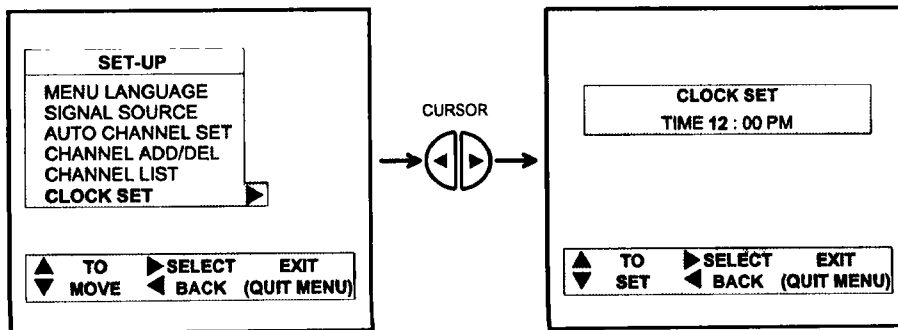

Use CURSOR ▲ or ▼ buttons to set the time and AM or PM.
Press CURSOR ► to change position.
Press MENU/EXIT to quit menu or CURSOR ◀ to return to previous menu.

CUSTOMIZE



CUSTOMIZE

This selection contains advanced features which will make TV viewing easier and more enjoyable.

CHANNEL ID

Use this feature to give up to 25 channels a name.

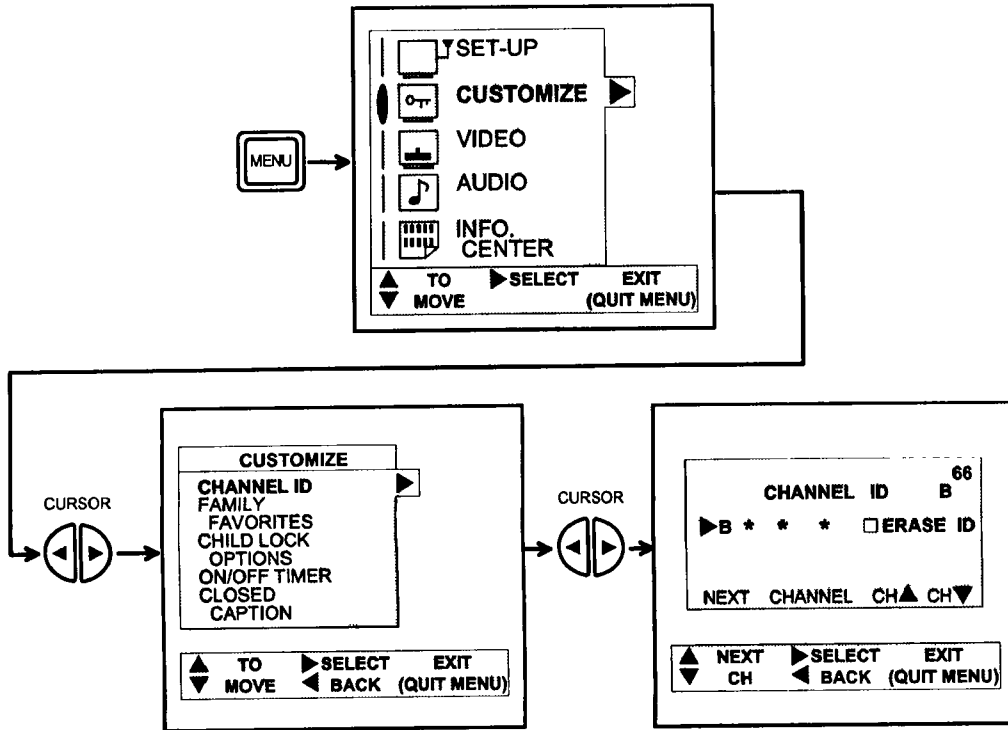

- Press CURSOR ▲ or ▼ to select letters.
- Press CURSOR ► to change character position.
- Press CHANNEL ▲ or ▼ to select and label additional channels.
- Press MENU/EXIT to quit menu or CURSOR ◀ to return to previous menu.

The CHANNEL ID will appear in the top right corner of the screen when the RECALL button is pressed.

The (*) represents a blank space.
Select ERASE ID to erase a CHANNEL ID. "ARE YOU SURE?" display will appear on the screen to confirm your choice.

NOTE: CHANNEL ID will be displayed only when channel is displayed as main picture.



CUSTOMIZE

FAMILY FAVORITES

This function allows you to group your favorite channels into 4 personalized categories that you can register.

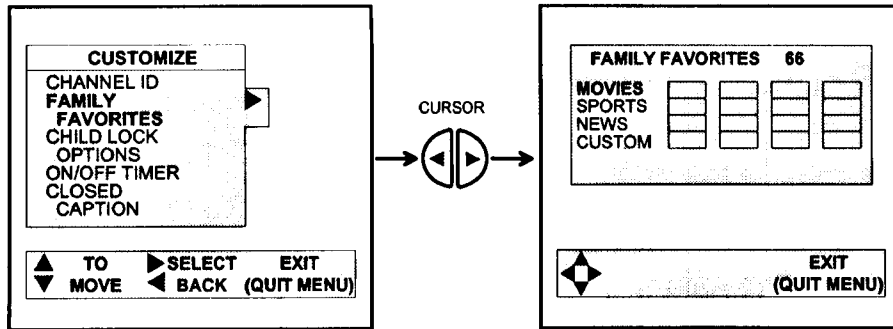

Use CURSOR ▲ or ▼ buttons to highlight the category you wish to register the channel under.
 Press CURSOR ► to select the column you wish to register the channel under.
 Press CHANNEL ▲ or ▼ or the number buttons to enter the desired channel. The channel to be added is displayed in the top right corner of the screen.
 Press MENU button to register your favorite channel.
 Repeat until the category has been registered with your favorite channels.
 To erase a FAMILY FAVORITES channel, enter 00 as channel then press MENU button.

Once your favorite channels are registered in the FAMILY FAVORITES menu, your TV set will change to that station when selected.

Press EXIT to remove FAMILY FAVORITES OSD from the SCREEN.

NOTE: After all of your favorite channels are registered, the CURSOR buttons can be used for quick access to the FAVORITE CHANNELS menu.

CUSTOMIZE



CHILD LOCK OPTIONS

This function will block out the picture and sound of the selected channel or video input. It can also be used to schedule an amount of time that the TV cannot be viewed.

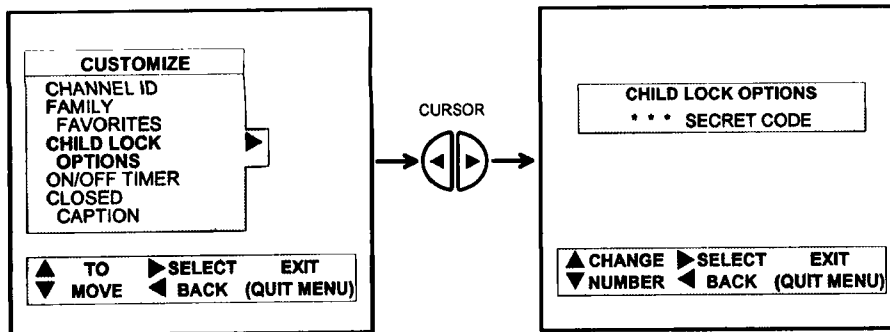

The code to enter CHILD LOCK is a three digit key number. The factory preset code is 000. Use CURSOR ▲ or ▼ to select number or CURSOR ► to change position.

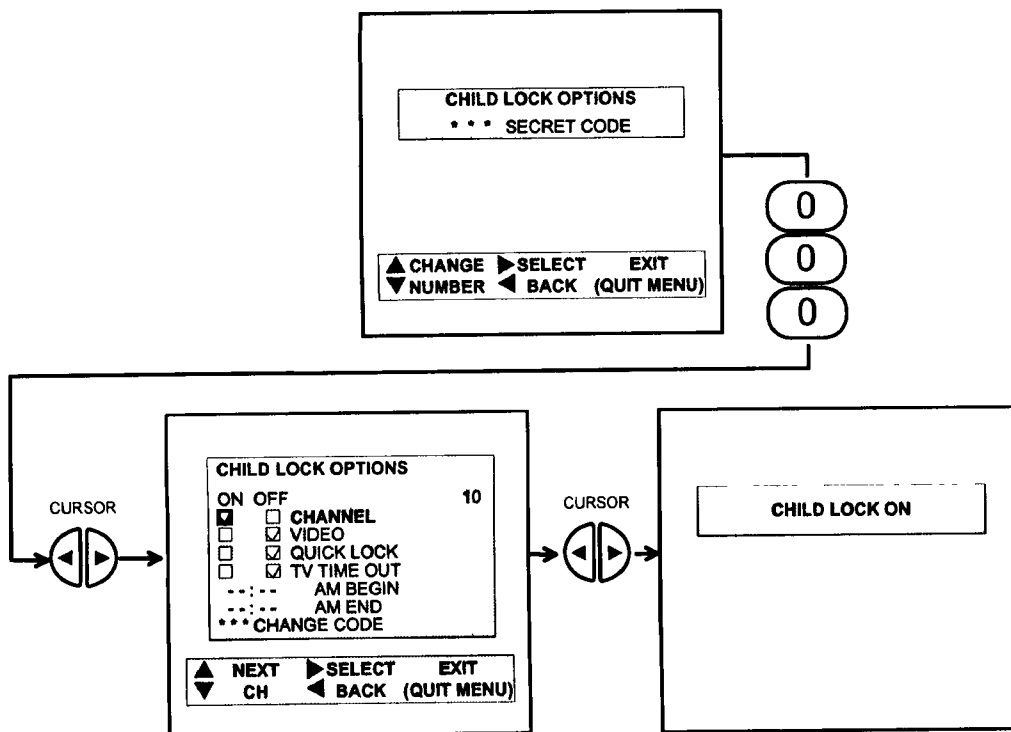

Use CURSOR ▲ or ▼ to highlight function and CURSOR ► to set ON or OFF.

When CHANNEL is turned on, the picture and sound for the chosen channel will be blocked out.

When VIDEO is turned on, the picture and sound for the video input will be blocked out.

When QUICK LOCK is turned on, the picture and sound for channels 3, 4 and all video input will be blocked out.

When TV TIME OUT is turned on, you can set the BEGIN and END times and the TV cannot be viewed during that time period.

To change the key number, select CHANGE CODE. Enter a new three digit key number you prefer.

If you forget your key number, use the factory code 777 to erase your key number. This will reset the key number back to the factory preset 000.

ON/OFF TIMER

This function will automatically turn the TV set on or off one time only, every day, or once a week.

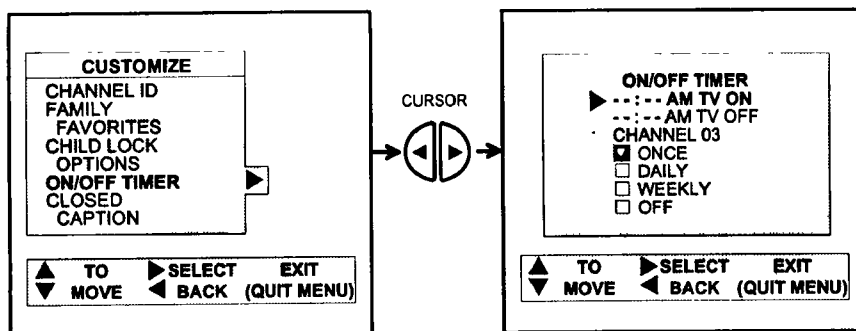

Press CURSOR ▲ or ▼ to select either the ON or OFF TIMER.
 Press CURSOR ► to highlight selection to be changed.
 Press CURSOR ▲ or ▼ to select the time the TV will turn on and off and to choose AM or PM.
 Press CURSOR ◀ to exit time setting

Select CHANNEL and press CHANNEL ▲ or ▼ to set the channel the TV will tune to when it automatically turns on.
 Press CURSOR ◀ to exit channel setting.

Press CURSOR ▲ or ▼ to highlight then CURSOR ► to select mode: ONCE(one time only), DAILY(every day), or WEEKLY(once a week).
 Press MENU/EXIT to quit menu or CURSOR ◀ to return to previous menu.

NOTE: You can set either on time only or off time only, or both. The mode will be the same for both.

If the TV is turned on due to ON TIMER and there is no remote control operation in 3 hours or more, the TV will automatically turn off.



CAUTION: Do not use your TV as a deterrent when away from home by using both the ON TIMER and OFF TIMERS. For safety, the TV should be turned off when you are away from home.

CUSTOMIZE



CLOSED CAPTION

Closed captions are the dialogue, narration, and/or sound effects of a television program or home video which are displayed on the TV screen. Your local TV program guide denotes these programs as **cc** or .

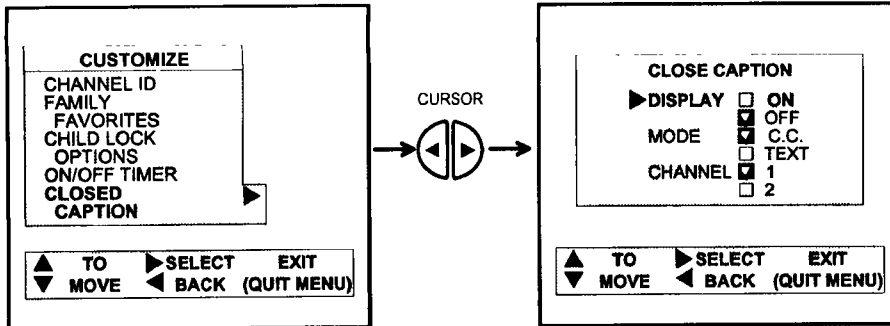

DISPLAY: ON/OFF will turn the **cc** display on or off.

MODE: C.C. (Closed Caption) is for the program you are viewing.

MODE: TEXT is for additional information such as news reports or a TV program guide. This information covers the entire screen and viewing the TV program is not possible. TEXT may not be available with every **cc** program.

CHANNEL: 1 is used for the primary language (usually English).

CHANNEL: 2 is sometimes used for a second language (may vary by region).

Use CURSOR **▲** or **▼** to highlight the function to be changed; press CURSOR **▶** to change the function. Press MENU/EXIT to quit menu or CURSOR **◀** to return to previous menu.



C.C. Selected

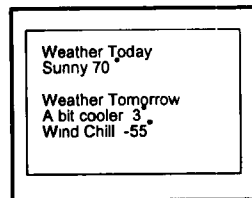

Text Selected

NOTE: The word MUTE will not be displayed if the Closed Caption Display is ON. If you do not have sound, make sure MUTE is not set.



Select VIDEO to adjust picture settings and improve picture quality.

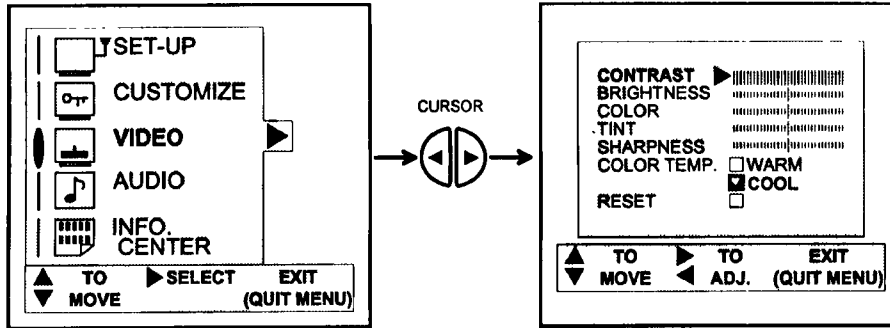

Use the CURSOR ▲ or ▼ to highlight the function to be adjusted.
 Press CURSOR ◀ or ▶ to adjust the function.
 Press MENU/EXIT to quit menu or CURSOR ◀ to return to previous menu.

CONTRAST

Use this function to change the contrast between black and white levels in the picture.

BRIGHTNESS

Use this function to adjust overall picture brightness.

COLOR

Use this function to adjust the level of color in the picture.

TINT

Use this function to adjust flesh tones so they appear natural.

SHARPNESS

Use this function to adjust the amount of fine detail in the picture.

COLOR TEMP.

Use this function to adjust the white balance (hue) of the picture to your own color preference.
 When shipped from the factory, this is set to "COOL". If you prefer a reddish screen, set to "WARM".

RESET

When RESET is selected, press CURSOR ▶ to return video adjustments to factory preset conditions.

AUDIO



Select AUDIO to adjust the TV to your preference and to improve the sound quality.

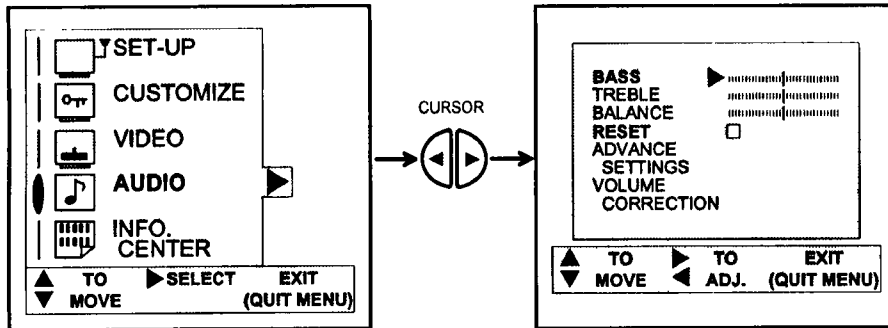

Use the CURSOR ▲ or ▼ to highlight the function to be adjusted.
Press CURSOR ◀ or ▶ to adjust the function.
Press MENU/EXIT to quit menu or CURSOR ◀ to return to previous menu.

BASS

This function controls the low frequency audio to all speakers.

TREBLE

This function controls the high frequency audio to all speakers.

BALANCE

This function will control the left to right balance of the TV internal speakers and the AUDIO TO HI FI output.

RESET

When RESET is selected, press CURSOR ▶ to return audio adjustments to factory preset conditions.



ADVANCED SETTINGS

Use ADVANCED SETTINGS to improve the sound performance of your TV depending on listening conditions.

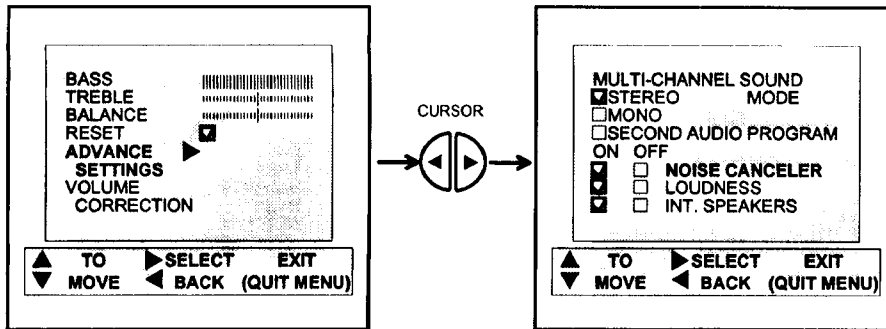

Press CURSOR ▲ or ▼ to highlight a function.
 Press CURSOR ► to change the function setting.
 Press MENU/EXIT to quit menu or CURSOR ◀ to return to previous menu.

MTS MODE

Multi-Channel Television Sound (MTS) will allow you to select STEREO (a stereo broadcast), SAP (second audio program) which may be a secondary language, weather report, etc. or MONO (monaural sound) used when receiving a weak stereo broadcast.

The sources received will be displayed below the channel number. The MTS mode you selected will be displayed to the left of the channel number. See example below for each selection when both stereo and second audio are received (monaural is always received).

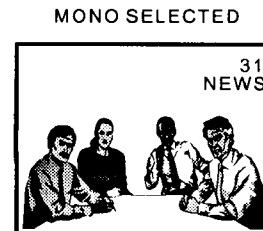
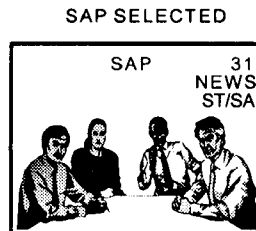

NOISE CANCELER

This function eliminates the noise in between stations. If a channel is tuned and is noisy, this function will automatically eliminate the audio and video for that channel.

LOUDNESS

This function will improve the quality of both low and high frequency sounds when listening at low volume levels.

INT. SPEAKERS

This function is useful when first setting up the external speakers, or if you prefer to use only speakers from a separate stereo system.

AUDIO



VOLUME CORRECTION

Use this function to reduce the volume level of up to four channels that sound loud compared to other channels.

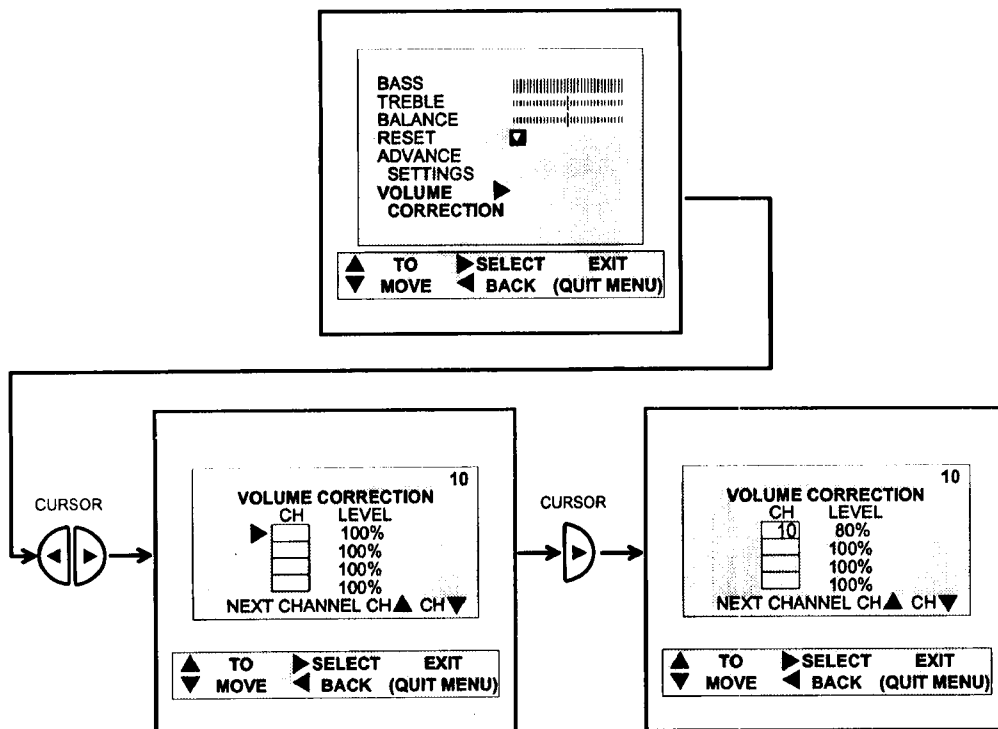

Press CURSOR ▲ or ▼ to highlight one of the four volume corrections, then CURSOR ► to select.
Press CHANNEL ▲ or ▼ and number buttons to select a channel.
Press MENU to set the channel to be volume corrected.
Press CURSOR ▲ or ▼ to adjust volume level in 5% increments.
Press MENU/EXIT to quit menu or CURSOR ◀ to return to previous menu.

- NOTE:**
1. Volume Correction adjustment is for the channel display in the top right corner of the screen. To adjust a different channel, you must select the channel with the channel or number buttons and press CURSOR ►.
 2. If the channel has been corrected before, use the CURSOR ▲ or ▼ to highlight and CURSOR ► to select that channel, then use the CURSOR ▲ or ▼ to change the level.
 3. To erase a channel from volume correction, select channel 00 and press MENU.
 4. The volume level will change from 50% to 100% in increments of 5%.



INFO CENTER

INFO CENTER

This function allows your TV to assist you with your busy day to day schedule.

PERSONAL MESSAGE

Use this function to program a message in your TV's memory up to a maximum of 31 characters. The user can program the message to appear one time only or every day.

Press CURSOR ▲ or ▼ to highlight your selections.

Press CURSOR ► to select your choice.

Press ▲ or ▼ to select letters or other characters.

The asterisk (*) represents a blank space.

To erase the message, use CURSOR ▲ or ▼ until ERASE MESSAGE is highlighted, then press CURSOR ► to erase message.

The "ARE YOU SURE?" display will appear on the screen to confirm your choice.

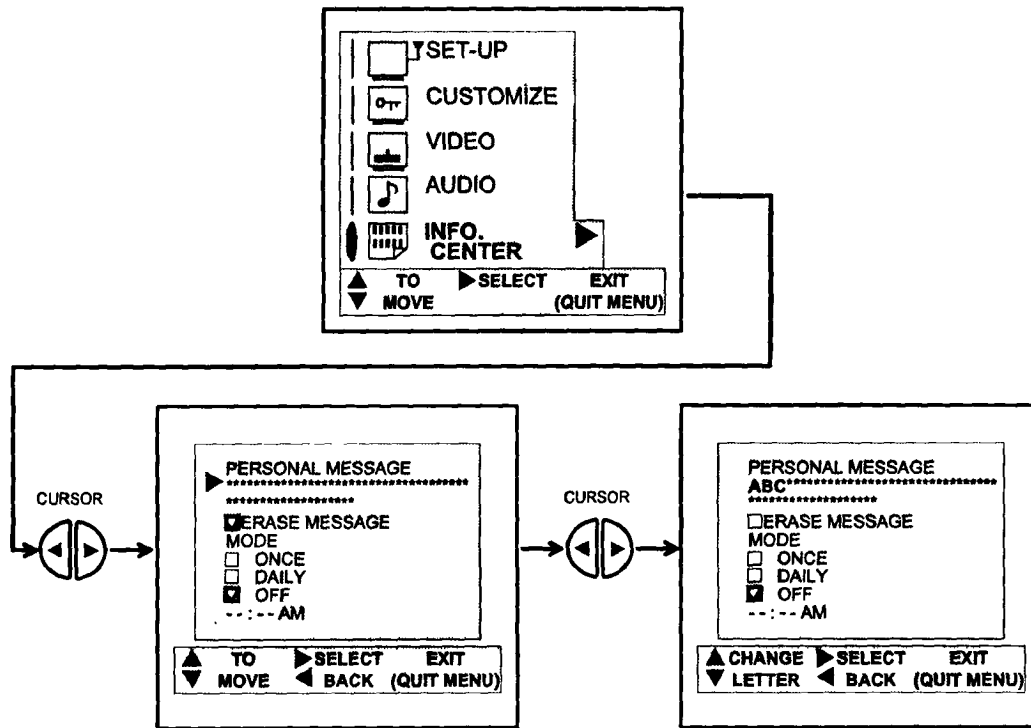

Press CURSOR ▲ or ▼ to choose MODE or TIME.

Press CURSOR ► to set MODE when it is highlighted.

Press CURSOR ▲ or ▼ to set the time.

Press MENU/EXIT to quit menu or CURSOR ◀ to return to previous menu.

NOTE: At the selected time, the message will be displayed until a remote control button is pressed.



DO

Make sure the TV is turned off when cleaning the screen.

Dust the screen and cabinet with a soft cloth.

Clean the screen with a soft cloth moistened in warm water. Dry with a soft cloth (A mild soap may be used if the screen is extremely dirty).

Place your TV and remote control away from extreme heat, humidity and extremely dusty places.

Remove the plug from the wall outlet if your television will not be used for a long period of time, for instance, when you go on vacation.

DO NOT

Do not clean your screen or cabinet with strong cleaners, polishes, or chemically treated cloth.

Do not place rubber or vinyl products or cellophane tape on your set.

Do not touch the screen too often.





Do not subject the remote control to shocks such as dropping it on the floor, etc. Physical damage to the precision parts may result.

Avoid placing the remote control in a high humidity place or getting it wet. Don't leave it on or near a heater. Excessive heat or moisture may cause the unit to cease operation.

When the batteries run down, remote control operation will become erratic or possibly stop altogether. Replace the old batteries with two fresh "AA" size batteries.

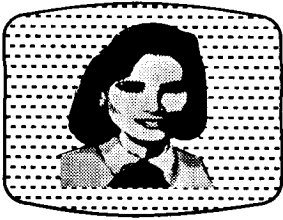

USEFUL INFO

	<ul style="list-style-type: none">• IGNITION NOISE: Black spots or horizontal streaks may appear, picture may flutter or drift. Usually caused by interference from automobile ignition systems, neon lamps, electrical drills, and other electrical appliances.
	<ul style="list-style-type: none">• GHOSTS: Ghosts are caused by the television signal following two paths. One is the direct path and the other is reflected from tall buildings, hills or some other objects. Changing the direction or position of the antenna may improve reception. Ghosting may also be caused by defects in the antenna system such as unshielded leads or committing several sets to the same antenna without using multiple antenna couplers.
	<ul style="list-style-type: none">• SNOW: If your receiver is located in the fringe area of a television station where the signal is weak, your picture may be marred by the appearance of small dots. When the signal is extremely weak, it may be necessary to install a special antenna to improve the picture.
	<ul style="list-style-type: none">• RADIO FREQUENCY INTERFERENCE The interference produces moving ripples or diagonal streaks, and in some cases, causes loss of contrast in the picture.



SYMPTOMS	CHECK THESE ITEMS AND TRY THESE ADJUSTMENTS											
	Be sure external connection is correct	Be sure power cord is plugged in	Be sure TV is switched "ON"	Try another channel (station trouble)	Check antenna connections (back of TV)	Check antenna for broken lead-in wire	Check for local interference	Adjust picture control	Adjust black level control	Adjust Color control	Adjust Tint control	Adjust Volume control
No Picture, no sound	●	●	●	●	●	●						
Sound OK, picture poor	●			●	●	●	●	●				
Picture OK, sound poor	●			●	●	●	●					●
Picture blurred	●			●	●	●	●					
Lines or streaks in picture				●	●	●	●					
Poor reception on some channels				●	●	●	●					
No color	●			●	●	●	●		●			
Poor color	●			●	●	●	●		●	●		

This Color Television incorporates advanced power surge protection technology designed to protect against component or circuit damage due to internal voltage or power surges.

IF YOUR SET SHOULD APPEAR TO HAVE A LOSS OF POWER, PLEASE FOLLOW THIS PROCEDURE:

- 1) Push the power switch (ON/OFF switch) once.
- 2) If there is still no power, wait 30 seconds and push the power switch again.
- 3) If there is still no power, unplug the power cord from the wall. Wait thirty seconds and plug the power cord back in. Push the power switch again.

This protective technology should provide for years of lasting entertainment from your Color Television.



Features:

- Superfine Picture Quality
600 Line Horizontal Resolution
- Dark Tint CPT
- Remote Transmitter
(Controls many VCR, Cable Box, and Satellite brands)
- P-in-P Functions
- ICONS: Color Graphic Guide
- Full set of Input Jacks, including S-Video
- Closed Caption Decoder
- Comb Filter, Wide-Band Video-Amp
- MTS (Multi-Channel Television Sound) Stereo Broadcast Reception

Screen Size: 27V (27 inches measured diagonally) 27CX7B and 27CX75B

Inputs:

- Power InputAC 120V, 60Hz
- Power Consumption (operating)
 - 27CX7B109W
 - 27CX75B109W
- Power Consumption (Maximum)
 - 27CX7B145W
 - 27CX75B145W
- Antenna input impedance75 Ohm
- Channel coverage181 ch.
 - VHF-Band2 ~ 13
 - UHF-Band14 ~ 69
 - CATV Mid BandA-5 ~ A-1
 -A-l
 - Super BandJ-W
 - Hyper BandW+1 - W+28
 - Ultra BandW+29 - W+84
- Video1.0Vp-p, 75 Ohm
- S-Video
 - Luminance (Y)1.0Vp-p, 75 Ohm
 - Chrominance (C)1.0Vp-p, 75 Ohm
- Audio input level47k Ohm
- Average input level470mVrms
- Maximum input level940mVrms

Dimensions:

	27CX7B	27CX75B
• Height (in.)	23 ¹ / ₃₂	23 ¹ / ₃₂
• Width (in.)	27 ¹ / ₄	27 ¹ / ₄
• Depth (in.)	20 ³ / ₁₆	20 ³ / ₁₆
• Weight (lbs.)	88	88



HITACHI

*Service
hotline*

To locate an authorized
HITACHI service facility
in the continental U.S.A.
and Canada,

DIAL TOLL FREE

7 days a week, 24 hours a day

800 HITACHI

1-800-448-2244

Hitachi Home Electronics (America), Inc.

Hitachi has made every effort to assure you hours of trouble free operation from your unit. However, should you require service, a network of Hitachi Authorized Service Facilities has been established in all 50 states and Puerto Rico. Each facility will provide you with convenient and expedient assistance. Our service "Hotline" operator will direct you to the Hitachi Authorized Service Facility nearest you. Just present proof of purchase and/or delivery receipts to the Hitachi Authorized Service Facility, and service will be rendered in accordance with the terms of the limited warranty as stated on your warranty card or operating guide.

Should you have any questions regarding in-warranty service, operation or technical assistance, please contact:

Hitachi Home Electronics (America), Inc.
3890 Steve Reynolds Blvd.
Norcross, GA 30093
Tel: 770-279-5600

Hitachi Sales Corporation of Hawaii
3219 Koapaka St.
Honolulu, HI 96819
Tel: 808-839-3621

For TV's purchased in Canada only, please contact one of the Hitachi offices below, should you have any questions regarding service, operation or technical assistance.

MONTREAL
3300 Trans Canada
Pointe Claire, Quebec
H9R 1B1

Tel: (514) 697-9150
Fax: (514) 697-2209

TORONTO
6740 Campobello Road
Mississauga, Ontario
L5N 2L8

Tel: (905) 821-4545
Fax: (905) 826-6627

VANCOUVER
54 Humber Place, Annacia Industrial Estate
New Westminister, B.C.
V3M 6A6

Tel: (604) 526-8566
Fx: (604) 526-8127





HITACHI