

HITACHI

SOLID STATE COLOR TV

27CX1B

20SA5B

27CX15B

OPERATING GUIDE



IMPORTANT SAFEGUARDS

2 - 5

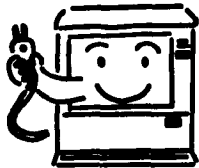

FIRST TIME USE

6 - 17



THE REMOTE CONTROL

18 - 28

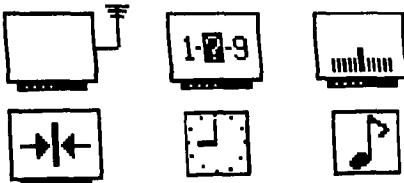

EASY GRAPHIC GUIDE

29 - 42

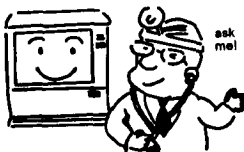

**USEFUL INFORMATION
INDEX**





43 - 47



IMPORTANT

Your new HITACHI COLOR TV incorporates a host of features designed to give you excellent performance if you follow the instructions in this manual. We recommend that you read the following instructions and "IMPORTANT SAFEGUARDS" notice before turning on your TV set for the first time.

Follow all warnings and instructions marked on this television receiver.

	CAUTION RISK OF ELECTRIC SHOCK DO NOT OPEN			The lightning flash with arrowhead symbol, within an equilateral triangle, is intended to alert the user to the presence of uninsulated "dangerous voltage" within the product's enclosure that may be of sufficient magnitude to constitute a risk of electric shock to persons.
CAUTION: TO REDUCE THE RISK OF ELECTRIC SHOCK, DO NOT REMOVE COVER (OR BACK) NO USER-SERVICEABLE PARTS INSIDE. REFER SERVICING TO QUALIFIED SERVICE PERSONNEL.				The exclamation point within an equilateral triangle is intended to alert the user to the presence of important operating and maintenance (servicing) instructions in the literature accompanying the appliance.

WARNING:
**TO PREVENT FIRE OR SHOCK HAZARD, DO NOT
EXPOSE THIS TELEVISION SYSTEM TO RAIN OR MOISTURE.**

NOTE:



- There are no user serviceable parts inside the receiver.
- Model number and serial number are indicated on back side of the set.

POWER SOURCE:

This HITACHI color TV is designed to operate on 120 volts 60 Hz, AC household current. Insert power cord into a 120 volt 60 Hz outlet.

TO PREVENT ELECTRIC SHOCK, DO NOT USE THE TELEVISION'S PLUG WITH AN EXTENSION CORD, RECEPTACLE, OR OTHER OUTLET UNLESS THE BLADES AND GROUND TERMINAL CAN BE FULLY INSERTED TO PREVENT BLADE EXPOSURE.

NEVER CONNECT THE TV TO 50 Hz, DIRECT CURRENT, OR ANYTHING OTHER THAN THE SPECIFIED VOLTAGE.

NOTE: This television receiver will display television closed captioning, ( or ), in accordance with paragraph 15.119 of the FCC rules.

SAFETY TIPS



IMPORTANT SAFEGUARDS

CAUTION:

- Read all of these instructions
- Save these instructions for later use.
- Follow all warnings and instructions marked on the television receiver.

SAFETY POINTS YOU SHOULD KNOW ABOUT YOUR HITACHI TELEVISION RECEIVER

Our reputation has been built on the quality, performance, and ease of service of HITACHI television receivers.

Safety is also foremost in our minds in the design of these units. To help you operate these products properly, this section illustrates safety tips which will be of benefit to you. Please read it carefully and apply the knowledge you obtain from it to the proper operation of your HITACHI television receiver.

Please fill out your warranty card at once and mail it to HITACHI. This will enable HITACHI to notify you promptly in the improbable event that a safety problem should be discovered in your model of product.

FOR YOUR PERSONAL SAFETY

1 This television set is equipped with a polarized alternating-current line plug (a plug having one blade wider than the other). This plug will fit into the power outlet only one way. This is a safety feature. If you are unable to insert the plug fully into the outlet, try reversing the plug. If the plug should still fail to fit, contact your electrician to replace your obsolete outlet. Do not defeat the safety purpose of the polarized plug.



2 When the power cord or plug is damaged or frayed, unplug this television set from the wall outlet and refer servicing to qualified service personnel.

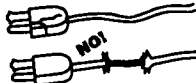

3 Do not overload wall outlets and extension cords as this can result in fire or electric shock.



4 Do not allow anything to rest on or roll over the power cord, and do not place the TV where the power cord is subject to traffic or abuse. This may result in a shock or fire hazard.



5 Do not attempt to service this television set yourself as opening or removing covers may expose you to dangerous voltage or other hazards. Refer all servicing to qualified service personnel.



6 Never push objects of any kind into this television set through cabinet slots as they may touch dangerous voltage points or short out parts that could result in a fire or electric shock. Never spill liquid of any kind on the television set.

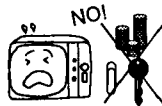

7 If the television set has been dropped or the cabinet has been damaged, unplug this television set from the wall outlet and refer servicing to qualified service personnel.

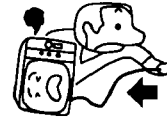

8 If liquid has been spilled into this television set, unplug it from the wall outlet and refer service to qualified service personnel.



9 Do not subject your television set to impact of any kind. Be particularly careful not to damage the picture tube surface.



10 Unplug this television set from the wall outlet before cleaning. Do not use liquid cleaners or aerosol cleaners. Use a damp cloth for cleaning.



11-1 Do not place this television set on an unstable cart, stand, or table. The television set may fall, causing serious injury to a child or an adult, and serious damage to the appliance. Use only with a cart or stand recommended by the manufacturer, or sold with the television set. Wall or shelf mounting should follow the manufacturer's instructions, and should use a mounting kit approved by the manufacturer.



11-2 An appliance and cart combination should be moved with care. Quick stops, excessive force, and uneven surfaces may cause the appliance and cart combination to overturn.



PROTECTION AND LOCATION OF YOUR SET

12 Do not use this television set near water, for example, near a bathtub, washbowl, kitchen sink, or laundry tub, in a wet basement, or near a swimming pool, etc.



• Never expose the set to rain or water. If the set has been exposed to rain or water, unplug the set from the wall outlet and refer to servicing personnel.

13 Choose a place where light (artificial or sunlight) does not shine directly on the screen.



14 Avoid dusty places, since accumulated dust inside the chassis may cause failure of the set when high humidity persists.



15 The set has slots, or openings in the cabinet for ventilation purposes, to provide reliable operation of the receiver, and to protect from overheating. These openings must not be blocked or covered.



• Never cover the slots or openings with cloth or other material.



• Never block the bottom ventilation slots of the set by placing it on a bed, sofa, rug, etc.

• Never place the set near or over a radiator or heat register.



• Never place the set in a "built-in" enclosure, unless proper ventilation is provided.





SAFETY TIPS

PROTECTION AND LOCATION OF YOUR SET

- 16-1 If an outside antenna is connected to the television set, be sure the antenna system is grounded so as to provide some protection against voltage surges and built up static charges. Section 810 of the National Electrical Code, NFPA No 70-1975, provides information with respect to proper grounding of the mast and supporting structure,

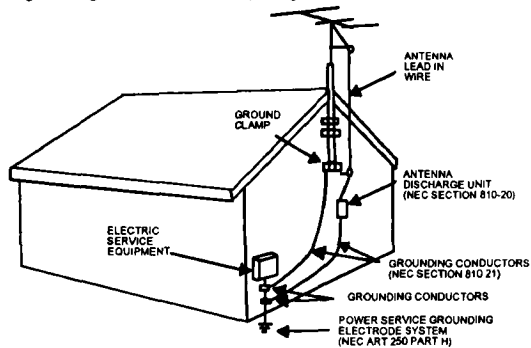

NEC NATIONAL ELECTRICAL CODE

EXAMPLE OF ANTENNA GROUNDING AS PER NATIONAL ELECTRICAL CODE INSTRUCTIONS

grounding of the lead-in wire to an antenna discharge unit, size of grounding conductors, location of antenna discharge unit, connection to grounding electrode, and requirements for the grounding electrode

- 16-2 Note to CATV system installer.
(Only for the television set with CATV reception)
This reminder is provided to call the CATV system installer's attention to Article 820-40 of the NEC that provides guidelines for proper grounding and, in particular, specifies that the cable ground shall be connected to the grounding system of the building, as close to the point of cable entry as practical.

- 17 An outside antenna system should not be located in the vicinity of overhead power lines or other electrical lights or power circuits, or where it can fall into such power lines or circuits. When installing an outside antenna system, extreme care should be taken to keep from touching such power lines or circuits as contact with them might be fatal.

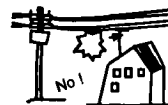

- 18 For added protection for this television set during a lightning storm, or when it is left unattended and unused for long periods of time, unplug it from the wall outlet and disconnect the antenna. This will prevent damage due to lightning and power-line surges.



OPERATION OF YOUR SET

- 19 This television set should be operated only from the type of power source indicated on the marking label. If you are not sure of the type of power supply at your home, consult your television dealer or local power company. For television sets designed to operate from battery power, refer to the operating instructions.



- 20 If the television set does not operate normally by following the operating instructions, unplug this television set from the wall outlet and refer servicing to qualified service personnel. Adjust only those controls that are covered in the operating instructions as improper adjustment of other controls may result in damage and will often require extensive work by a qualified technician to restore the television set to normal operation.



- 21 When going on a holiday: If your television set is to remain unused for a period of time, turn the television set "OFF" and unplug it from the wall outlet.



IF THE SET DOES NOT OPERATE PROPERLY

- 22 If you are unable to restore normal operation by following the detailed procedure in your operating instructions, do not attempt any further adjustment. Unplug the set and call your dealer or service technician.



- 23 Whenever the television set is damaged or fails, or a distinct change in performance indicates a need for service, unplug the set and have it checked by a professional service technician.

- 24 It is normal for some TV sets to make occasional snapping or popping sounds, particularly when being turned on or off. If the snapping or popping is continuous or frequent, unplug the set and consult your dealer or service technician.



FOR SERVICING AND MODIFICATION

- 25 Do not use attachments not recommended by the television set manufacturer as they may cause hazards.



- 26 When replacement parts are required, be sure the service technician has used replacement parts specified by the manufacturer that have the same characteristics as the original part. Unauthorized substitutions may result in fire, electric shock, or other hazards.

- 27 Upon completion of any service or repairs to the television set, ask the service technician to perform routine safety checks to determine that the television is in safe operating condition.



PICTURE CAUTIONS



WARNING



ACCESSORIES

Check to make sure you have the following accessories before disposing of the packing material.

1. Remote Control Unit (See Part No. Below)
2. Two "AA" size, 1.5V batteries (For Remote Control Unit)

For information regarding how to obtain these accessories, please call TOLL FREE 1-800-448-2244 for your nearest HITACHI Authorized Parts Distributor in the continental United States. For Alaska and Hawaii, please contact your nearest HITACHI Regional office.

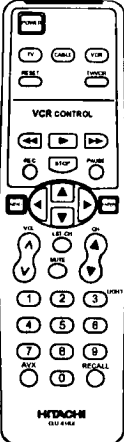
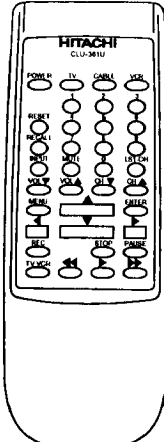
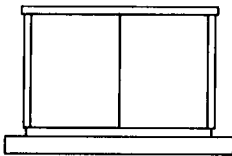
PART NAME	PART NO.	ILLUSTRATION	
27CX15B CLU-414UI REMOTE CONTROL	HL00223	 CLU-414UI	 CLU-361U
27CX1B/20SA5B CLU-361U REMOTE CONTROL	HL00551		
27V TELEVISION STAND SP271B (Not included, order Separately)	H530021		<p>CUSTOM HITACHI TELEVISION STAND</p> <p>Excellent for VCR and videotape storage. Special Features: curved smoke glass doors adjustable shelf. Available in Black.</p>



CAUTION: The television stand model SP271B is designed for use only with HITACHI TV models 27CX1B and 27CX15B. Use with other television equipment may result in instability, causing possible injury.

REMOTE CONTROL BATTERY INSTALLATION AND REPLACEMENT



1. Open the battery cover of the remote transmitter by pushing the notched part of the cover with your fingers.
2. Insert new "AA" size batteries or equivalent for the Remote. When replacing old batteries, push them towards the springs and lift them out.
3. Match the (+) and (-) marks in the battery compartment.
4. Replace the cover.

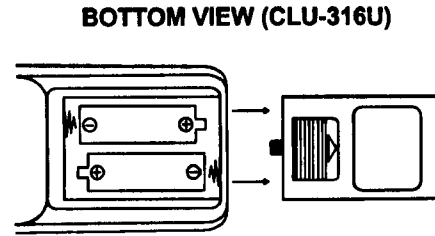
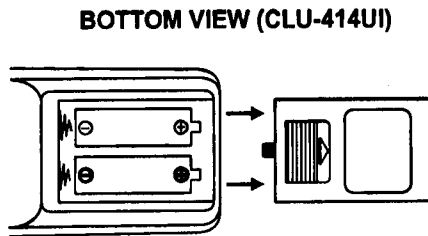
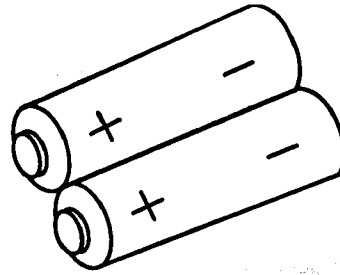

CAUTIONS

1. If your television set is to remain unused for a long period of time, for instance, when you go on a vacation, unplug the television set from the wall outlet.
2. Do not subject the Remote Transmitter to shocks such as dropping it on the floor, etc. Precision parts may be damaged.
3. Do not allow the Remote Transmitter to become wet and avoid placing it in areas of high humidity. Don't leave it on or near a heater. Excess heat or moisture may cause the unit to cease operation.
4. If the batteries become exhausted, Remote Control operation may become erratic or stop altogether. Replace the old batteries with fresh "AA" types.

NOTES

1. The Channel No. Indication, Volume Indication and OFF TIMER Indication are not displayed simultaneously.
2. To operate your TV, point the Remote Transmitter at the remote sensor of the TV.



HOW TO SET UP YOUR NEW HITACHI COLOR TV

ANTENNA

Unless your TV is connected to a cable TV system or to a centralized antenna system, a good outdoor color TV antenna is recommended for the best performance. However, if you are located in an exceptionally good signal area that is free from interference and multiple image ghosts, an indoor antenna may be sufficient.

LOCATION

Select an area where sunlight or bright indoor illumination will not fall directly on the picture screen. Also, be sure that the location selected allows a free flow of air to and from the cover of the set.

To avoid cabinet warping, cabinet color changes, and increased chance of set failure, do not place the TV where temperatures can become excessively hot. For example, in direct sunlight or near a heating appliance, etc.

VIEWING

The major benefit of the HITACHI Color Television is its viewing screen. To see this screen at its best, test various locations in the room to find the best spot for viewing. The drawings give several suggestions.

The best picture is seen by sitting directly in front of the TV and about 6 to 9 feet from the screen.

During daylight hours, reflections from outside light may appear on the screen. If so, drapes or screens can be used to reduce the reflection or the TV can be located in a different section of the room.

If the TV's audio output will be connected to a Hi-Fi system's external speakers, the best audio performance will be obtained by placing the speakers equidistant from each side of the receiver cabinet and as close as possible to the height of the picture screen center. For best stereo separation, place the external speakers at least 4 feet from the side of the TV. Place the surround speakers to the side or behind the viewing area. Differences in room sizes and acoustical environments will require some experimentation with speaker placement for best performance.

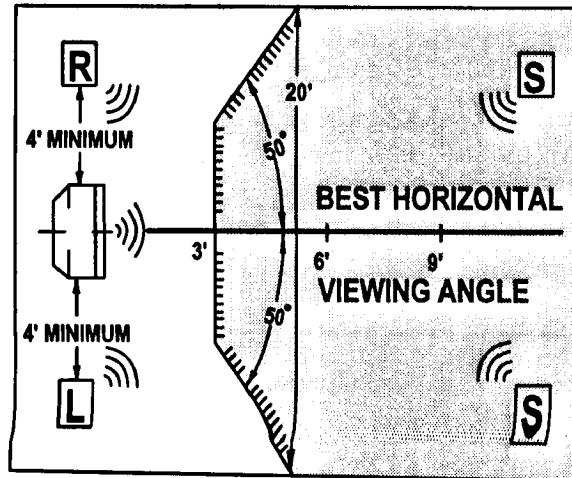
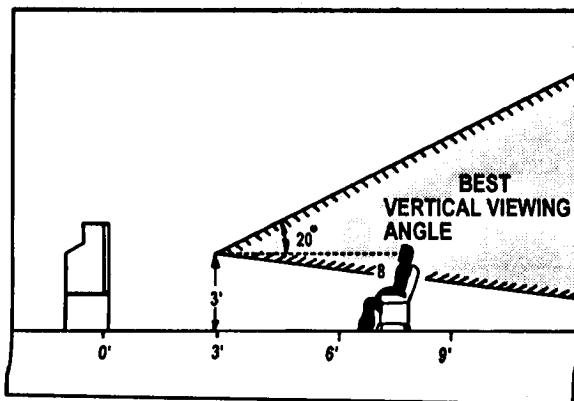

CAUTION: The magnetic field of external speakers may cause the TV picture to distort if the speakers are placed too close to the television. Move the speakers away from the TV until there is no picture distortion.



HOOKUP CABLES AND CONNECTORS

Most video/audio connections between components can be made with shielded video and audio cables that have phono connectors. For best performance, video cables should use 75-ohm coaxial shielded wire. Cables can be purchased from most stores that sell audio/video products. Below are illustrations and names of common connectors. Before purchasing any cables, be sure of the output and input connector types required by the various components. Also make sure the cables are the correct length.

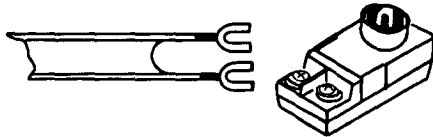

300-Ohm Twin Lead Connector

This outdoor antenna cable must be connected to an antenna adaptor (300-Ohm to 75-Ohm).



"F" Type 75-Ohm Coaxial Antenna Connector

For connecting RF signals (antenna or cable TV) to the antenna jack on the television.



Phono Connector

Used on all standard video and audio cables which connect to inputs and outputs located on the Television's front and rear jack panels.



S-Video (Super Video) Connector

This connector is used on camcorders, VCR's, and laser disc players with an S-Video feature in place of the standard video cable to produce a high-quality picture.

ANTENNA CONNECTIONS

These sets are equipped with one VHF/UHF antenna terminal. The VHF/UHF terminal can be used for normal TV, cable TV (CATV), a TV game, etc.

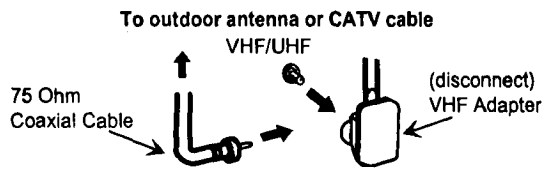
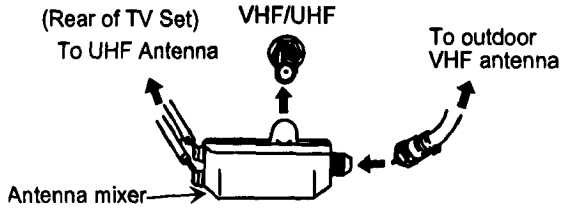
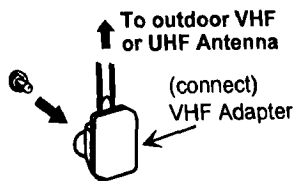
<p>1. VHF (75 Ohm) antenna/CATV When using a 75 ohm coaxial cable system, disconnect the VHF adaptor from the VHF 75 ohm receptacle and connect the outdoor antenna or CATV cable to a VHF 75 ohm receptacle.</p> 	<p>3. When both VHF and UHF antennas are connected Attach an optional ANT.MIXER to the TV antenna terminal, and connect the cables to the ANT. MIXER.</p> 
<p>2. VHF (300 Ohm) antenna/UHF antenna When using a 300 ohm twin lead from an outdoor antenna, disconnect the (VHF or UHF) indoor antenna leads from screws of the (VHF or UHF) adaptor, and connect outdoor (VHF or UHF) antenna leads to these screws of a (VHF or UHF) adaptor.</p> 	<p>Notes:</p> <ol style="list-style-type: none"> 1. If an outdoor antenna/CATV is to be used, disconnect the indoor antenna. Do not leave both the indoor and outdoor antennas/CATV connected at the same time, since ghosting and poor reception may result. 2. Consult your dealer or service store for the ANT. MIXER and (VHF or UHF) adaptor. 3. The special converter (decoder) will be supplied by the cable company.



FRONT PANEL CONTROLS FOR 27CX1B AND 27CX15B

FRONT VIEW

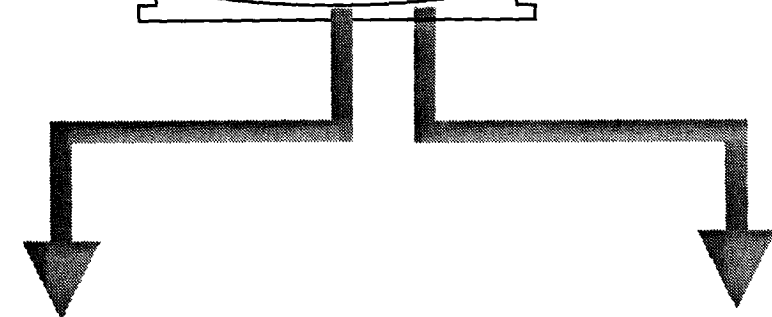
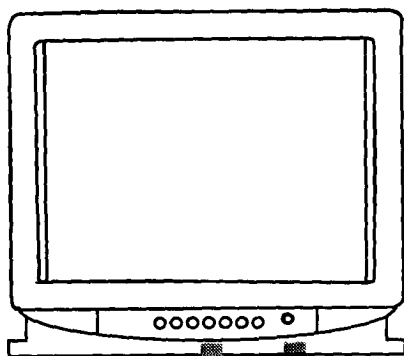

27CX1B

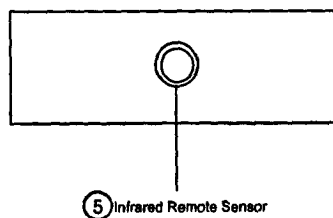
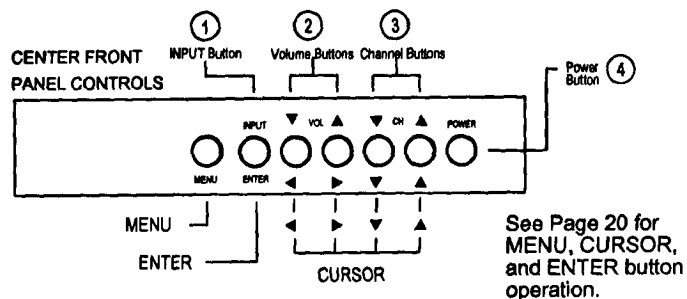

27CX15B

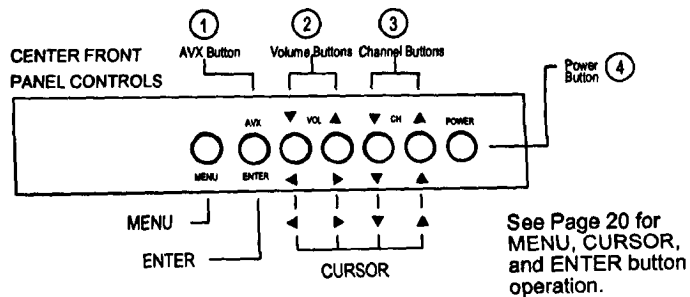

A detailed explanation of the circled numbers is on the following pages. (Example: ①).

NOTE: The "Program Icon", "Clock Icon" and Channel Memory Menu in "SETUP" are not displayed using the Front Menu Key. This feature uses the numbered buttons which are not in the front panel and the CH UP/DOWN button is disabled at Menu Function. For complete Menu Icon, use the remote control supplied.



FRONT PANEL CONTROLS FOR 20SA5B

FRONT VIEW

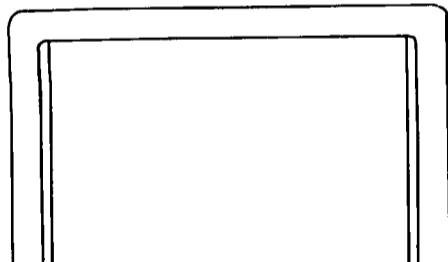



FRONT PANEL CONTROLS

- ① **INPUT(20SA5B/27CX1B) or AVX(27CX15B) (Audio/Video) Selector**
Press this button to select the current antenna source or VIDEO: 1. Your selection is shown in the top right corner of the screen. The AVX button on the front panel and the INPUT button on the remote control perform the same operations (CLU-361U only). Also the INPUT button on the 20SA5B and 27CX1B performs the same operation that the AVX button does on the 27CX15B.

- ② **VOLUME Level**
Press these buttons for your desired sound level. The volume level will be displayed on the TV screen.

- ③ **CHANNEL Selector**
Press these buttons until the desired channel appears in the top right corner of the TV screen.

- ④ **POWER Button**
Press this button to turn the TV on or off.

NOTE: Your HITACHI TV will appear to be turned "OFF" if there is no video input when VIDEO is selected. If you have no input to VIDEO, press the INPUT(20SA5B/27CX1B) or AVX(27CX15B) button until the normal broadcast picture appears (See page 22). If a picture does not appear, the power is "OFF".

- ⑤ **REMOTE CONTROL Sensor**
Point your Remote at this area when selecting channels, adjusting volume, etc.

REAR PANEL JACKS

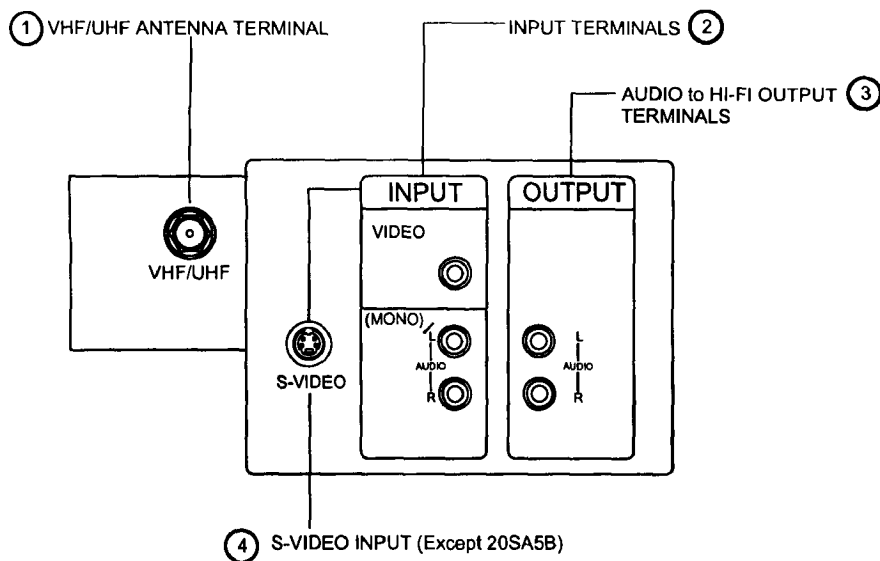

- ① **Antenna Inputs**
The VHF/UHF terminal can be used for normal TV, cable TV (CATV), a TV game, etc.
- ② **Audio/Video Input**
The INPUT(20SA5B/27CX1B) or AVX(27CX15B) (Auxiliary video) button will step through each video source and the current antenna input each time it is pressed. Use the audio and video inputs to connect external devices, such as VCR's, camcorders, laser disc players, video games, etc.
- ③ **Audio to Hi-Fi**
These jacks provide variable audio output to a separate stereo system amplifier. With this connection, the audio to the stereo can be controlled by the television's remote control.
- ④ **S-Video (except 20SA5B)**
Input 1 provides S-Video (Super Video) jacks for connecting equipment with S-Video output capability.

TIPS ON REAR PANEL CONNECTIONS

The S-Video connection is provided for high performance laser discs, VCR's, etc., that have this feature. Use this connection in place of the standard video connection if your device has this feature.

If your device has only one audio output (mono sound), connect it to the left audio jack on the TV.

Refer to the operating guide of your other electronic equipment for additional information on connecting your hookup cables.



REAR PANEL CONNECTIONS

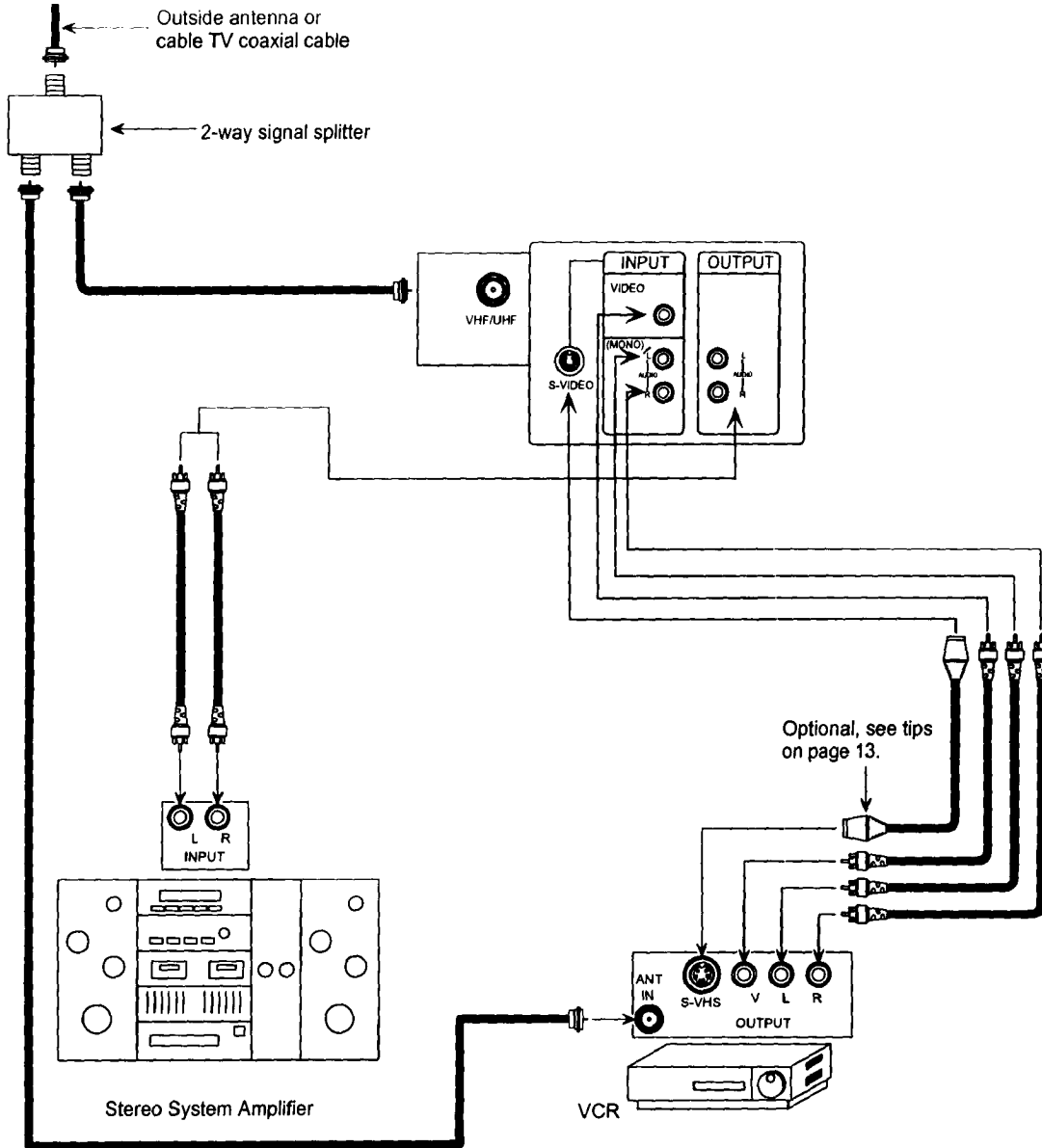

Typical full feature setup. Follow connections that pertain to your personal entertainment system.



EXTERNAL CONNECTIONS

CONNECTING EXTERNAL AUDIO AMPLIFIER

To control the audio level of an external audio amplifier with the remote transmitter, connect the system as shown below in Fig. 1.

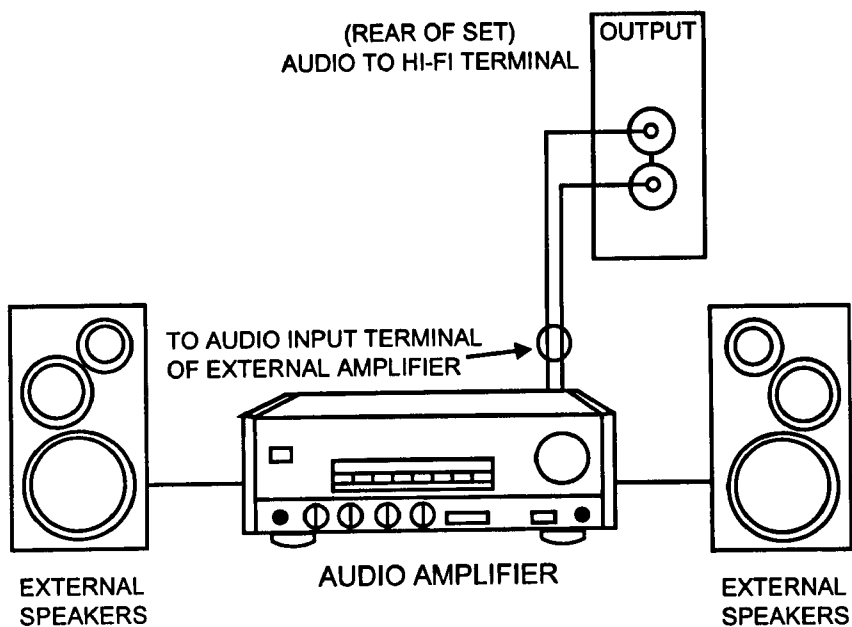

NOTE: To prevent damage to the speaker and distorted sound, set the volume control of the audio amplifier lower and adjust the sound level using the volume control on the remote transmitter of the TV set.



CONNECTING EXTERNAL VIDEO SOURCES

The exact arrangement you use to connect the Video Cassette Recorder, Video Disc Player and Video Camera to your TV set is dependent on the model and features of each component. Check the Owner's Manual of each component for the location of its video and audio inputs and outputs. The following connection diagrams are offered as suggestions. However, you may need to modify them to accommodate your particular assortment of components and features. For best performance, video and audio cables should be made from coaxial shielded wire.

Before Operating External Video Source

The input mode is changed every time the INPUT/AVX button is pressed as shown below. Connect External source to the INPUT terminal, then press the INPUT/AVX button as necessary to view the input source.

INPUT MODE SELECTION ORDER

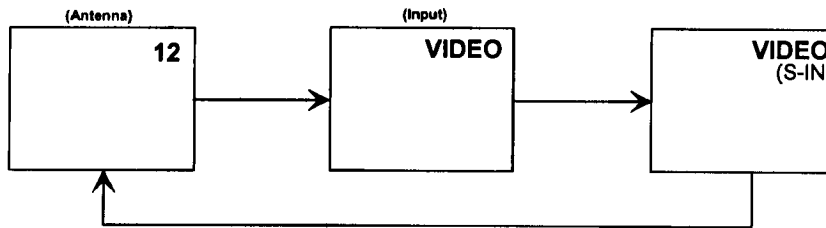

NOTE: When TV is set to "VIDEO" and a video signal is not received from VIDEO INPUT JACK on the jack panel of the TV (i.e., VCR/Video Disc Player, etc. is not connected or the video device is OFF), the screen will be grey-blue.

CONNECTING MONAURAL AUDIO VCR OR VIDEO DISC PLAYER

1. Connect the cable from the VIDEO OUT of the VCR or the Video Disc Player to the INPUT (VIDEO) jack on the TV set. (Fig. 1)
2. Connect the cable from the AUDIO OUT of the VCR or Video Disc Player to the INPUT (MONO)/L(AUDIO) jack. (Fig. 1)
3. Press the INPUT/AVX button to view the program from the VCR or Video Disc Player. The mode "VIDEO" disappears automatically after approximately 8 seconds.
4. Press the INPUT/AVX button to return to the previous channel.
5. See Below.

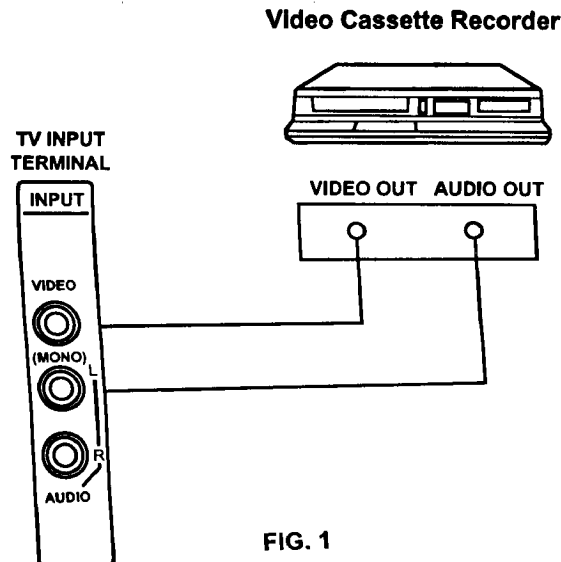



CONNECTING EXTERNAL VIDEO SOURCES

CONNECTING STEREO VCR OR STEREO VIDEO DISC PLAYER

1. Connect the cable from the VIDEO OUT of the VCR or the Video Disc Player to the "INPUT (VIDEO)" jack on the TV set. (Fig. 1)
2. Connect the cable from the AUDIO OUT "R" of the VCR or the Video Disc Player to the "INPUT(AUDIO/R)" jack. (Fig. 1)
3. Connect the cable from the AUDIO OUT "L" of the VCR or the Video Disc Player to the "INPUT(AUDIO/L)" jack. (Fig. 1)
4. Press the INPUT(20SA5B/27CX1B) or AVX(27CX15B) button to view the program from the VCR or Video Disc Player. The mode "VIDEO" disappears automatically after approximately 8 seconds.
5. Press the INPUT(20SA5B/27CX1B) or AVX(27CX15B) button to return to the previous channel.

Video Cassette Recorder

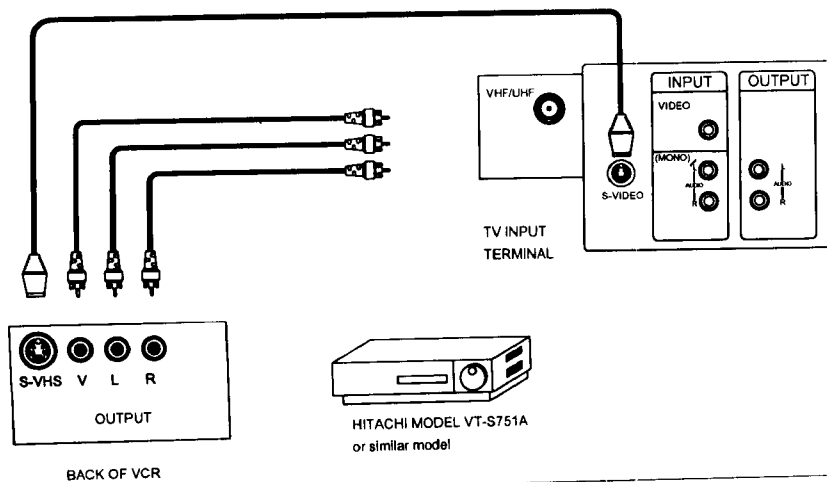
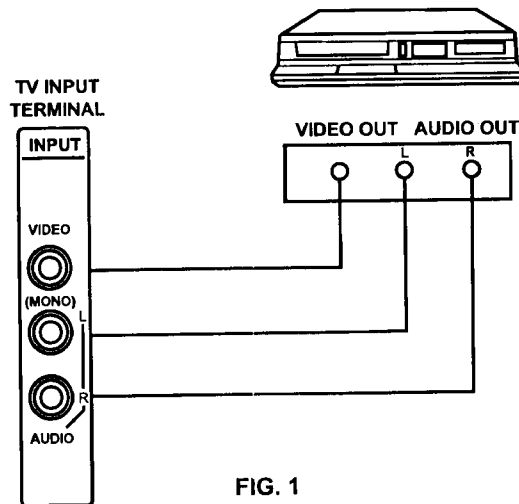

NOTE: Completely insert the connection cord plugs when connecting to REAR panel jacks. If you do not the picture that is played back may be abnormal.

If you have an S-VHS VCR, use the S-INPUT cable in place of the standard video cable.



THE REMOTE CONTROL (CLU-361U)

In addition to controlling all the functions on your HITACHI Color TV, the new remote is designed to operate different types of VCR's and CATV (Cable TV) converters with one touch. Basic operation keys are grouped together in one area.

To operate your TV, point the remote at the remote sensor of the TV and press the TV button on the remote. The remote will now control your TV.

To operate your VCR, point the remote at the remote sensor of the VCR and press the VCR button. The remote will now control your VCR. (See page 25 for instructions on how to program the remote to control your VCR.)

To operate your Cable Box, point the remote at the remote sensor of the Cable Box and press the CABLE button on the remote. The remote will now control your cable box. (See page 27 for instructions on how to program the remote to control your cable box.)

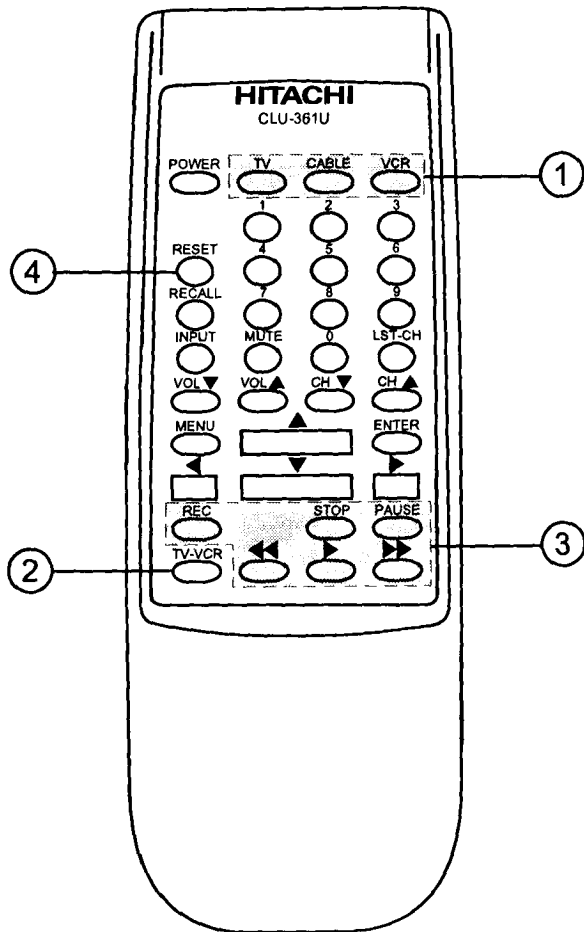

① These buttons allow the remote to control your TV, VCR, or Cable Box depending on which mode is chosen, as explained above.

② **TV/VCR BUTTON**
When the remote is in the TV or VCR mode, this is the TV/VCR button. When the remote is in the CABLE mode, this is the A/B button.

③ **PRECODED VCR BUTTONS**
These buttons always transmit the chosen pre-coded VCR codes.

④ **RESET BUTTON**
Press RESET to return video and audio to factory settings.

THE REMOTE CONTROL (CLU-414UI)



In addition to controlling all the functions on your HITACHI Color TV, the new remote is designed to operate different types of VCR's and CATV (Cable TV) converters with one touch. Basic operation keys are grouped together in one area.

To operate your TV, point the remote at the remote sensor of the TV and press the TV button on the remote. The remote will now control your TV.

To operate your VCR, point the remote at the remote sensor of the VCR and press the VCR button. The remote will now control your VCR. (See page 25 for instructions on how to program the remote to control your VCR.)

To operate your Cable Box, point the remote at the remote sensor of the Cable Box and press the CABLE button on the remote. The remote will now control your cable box. (See page 27 for instructions on how to program the remote to control your cable box.)

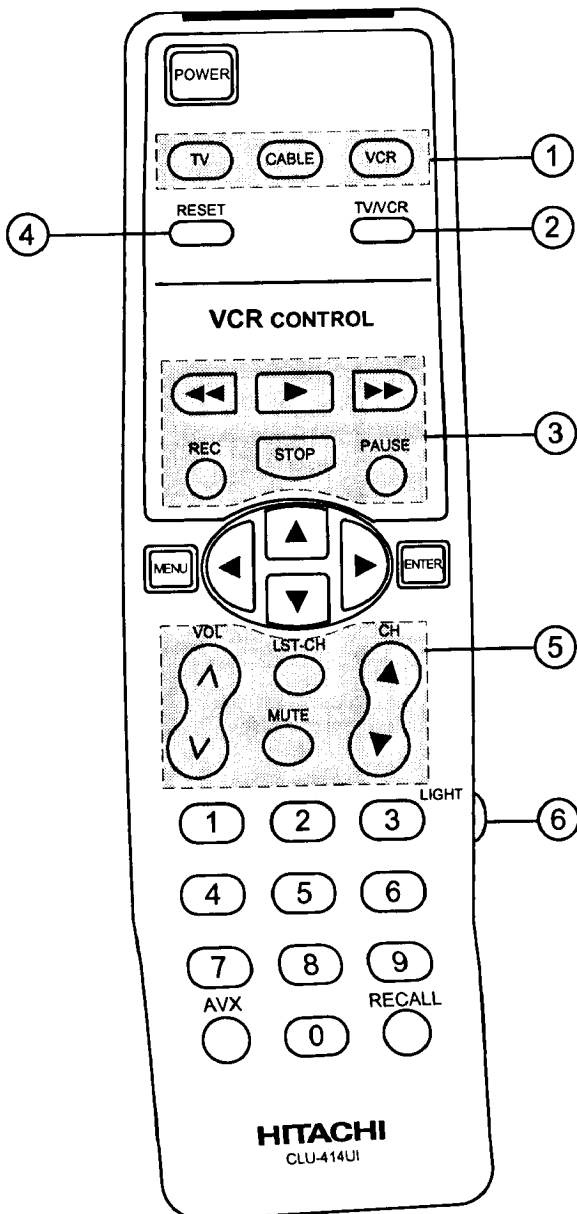

① These buttons allow the remote to control your TV, VCR, or Cable Box depending on which mode is chosen, as explained above.

② **TV/VCR BUTTON**
When the remote is in the TV or VCR mode, this is the TV/VCR button. When the remote is in the CABLE mode, this is the A/B button.

③ **PRECODED VCR BUTTONS**
These buttons always transmit the chosen pre-coded VCR codes.

④ **RESET BUTTON**
Press RESET to return video and audio to factory settings.

⑤, ⑥ **LIGHT BUTTON**
When you are in a dark room, press this button on the side of the remote to light up the buttons shown in ⑤. The light will stay on for about 8 seconds if the light button is not pressed again. These buttons will not appear to light if the room is too bright.



HOW TO USE THE REMOTE TO CONTROL YOUR TV

A detailed explanation of the circled numbers is on the following pages. (Example: ①).

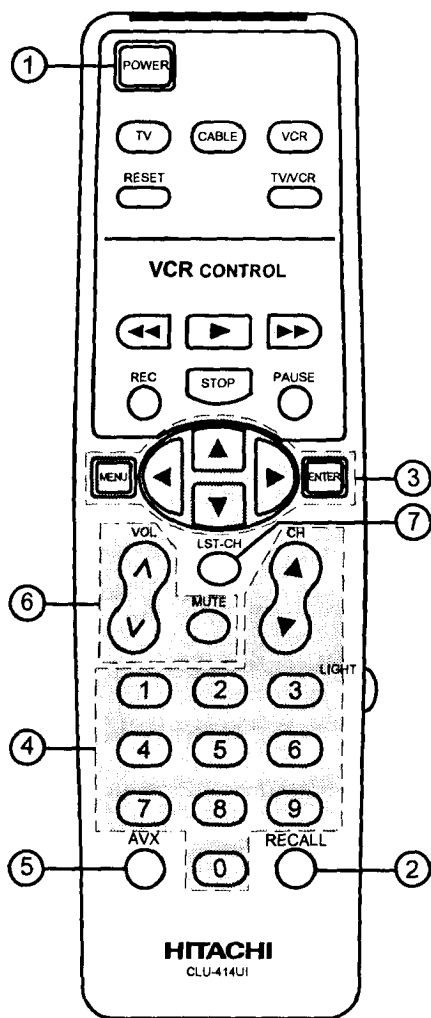
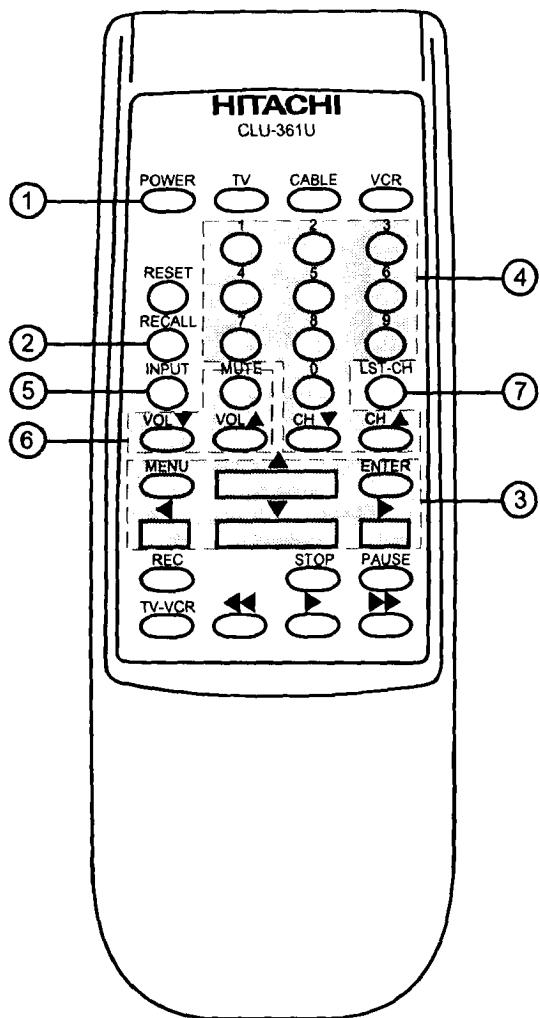

HOW TO USE THE REMOTE TO CONTROL YOUR TV



- ① **POWER Button**
Press this button to turn the TV set on or off. If a message is set, it will be displayed when the TV is first turned on. (See page 39.)
- ② **RECALL Button**
When you want to check the channel being received, or if it has a stereo (ST) or second audio program (SAP), press the RECALL button.

You can also check the time, and if the ON TIME or OFF TIME has been set. (See page 38.)

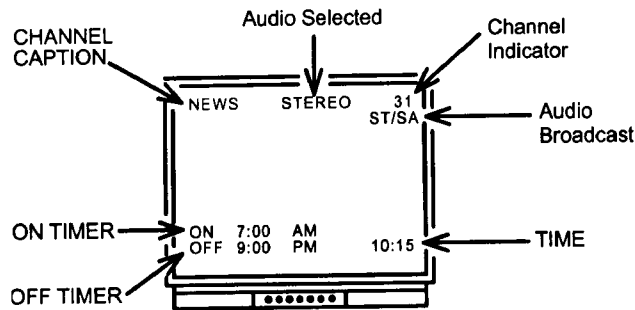

If a video input is used:

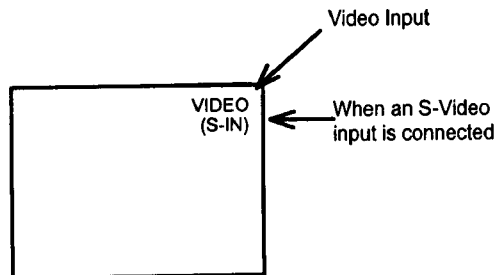

You can also use the RECALL button to quickly clear many of the other On-Screen Displays.



HOW TO USE THE REMOTE TO CONTROL YOUR TV

③ MENU, ENTER, CURSOR Buttons

All the on-screen display features can be set or adjusted by using these buttons.

The "MENU" button will start or exit the on-screen display.

The "CURSOR" buttons will highlight functions or adjust different features.

The "ENTER" button will set features to your preference.

④ CHANNEL SELECTOR Buttons

Enter two or three numbers to select channels. Enter a "0" first for channels 1 to 9.

For channels over 100, press 1 and wait for 2 seconds before pressing the last two digits of the channel.

Channel selection may also be performed by pressing channel up (▲) or down (▼).

NOTE: The TV may not receive some channels if you are not in the correct AIR/CABLE mode. See page 31.

⑤ INPUT(20SA5B/27CX1B) or AVX (27CX15B) Button

The INPUT(20SA5B/27CX1B) or AVX(27CX15B) (Auxiliary Video) button will select between the antenna signal and the video input jacks each time the button is pressed.

27CX1B/27CX15B

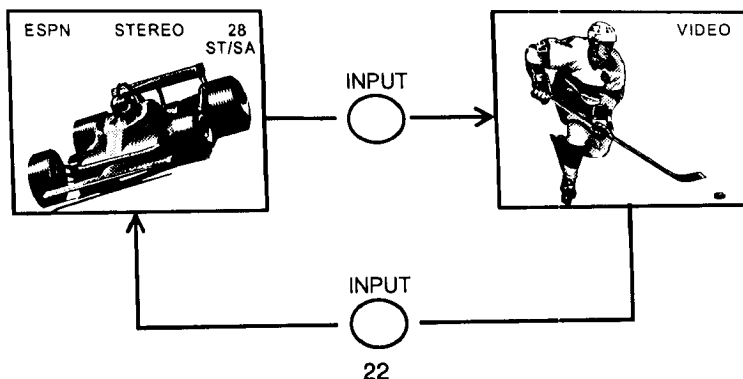
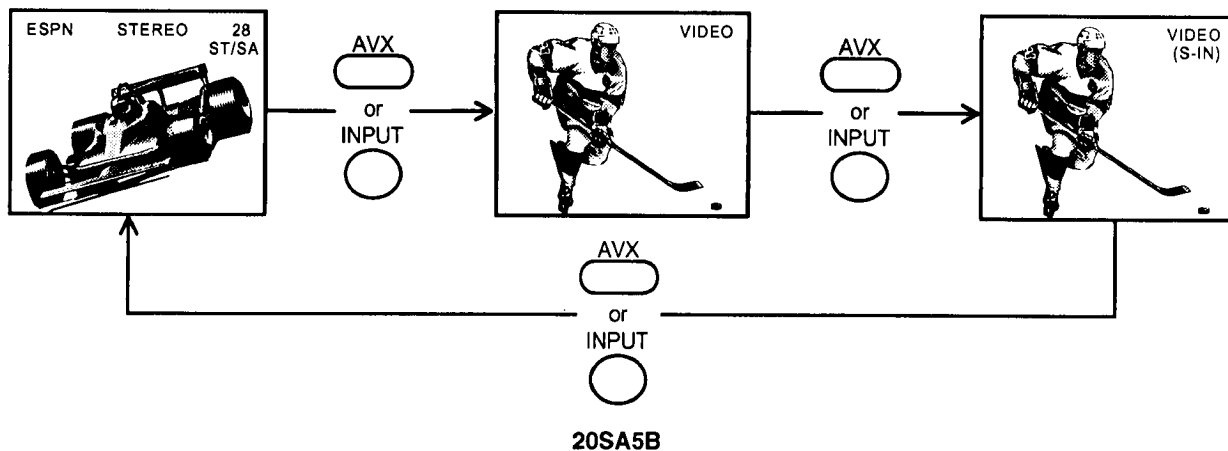

HOW TO USE THE REMOTE TO CONTROL YOUR TV



⑥ VOLUME, MUTE Buttons

Press the "VOLUME" up (▲) or down (▼) button until you obtain the desired sound level.

To turn the sound off instantly to answer the telephone, etc., press the "MUTE" button. Press the "MUTE" button again or press the "VOLUME" up (▲) button to restore the sound.

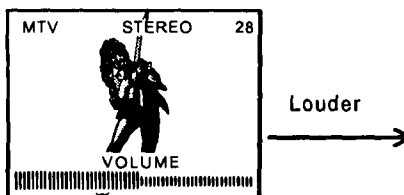

The word "MUTE" will remain displayed if the CLOSED CAPTION feature is turned off.

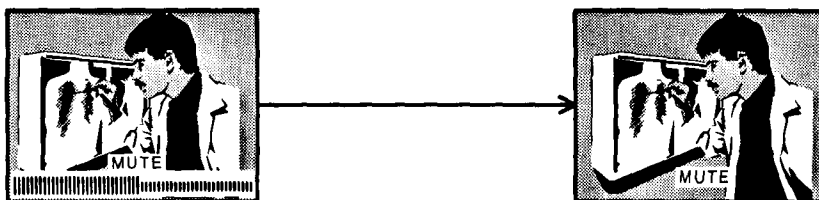

The word "MUTE" will not be displayed if the CLOSED CAPTION feature is on.



⑦ LAST CHANNEL (LST-CH) Button

Use this button to select between the last two channels viewed. (Good for watching two sporting events, etc.)

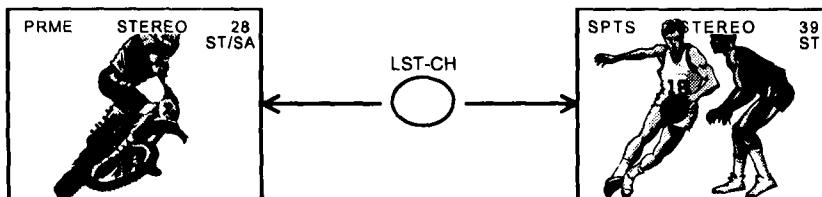



HOW TO USE THE REMOTE TO CONTROL VCR FUNCTIONS

A detailed explanation of the circled numbers is on the following pages. (Example: ①).

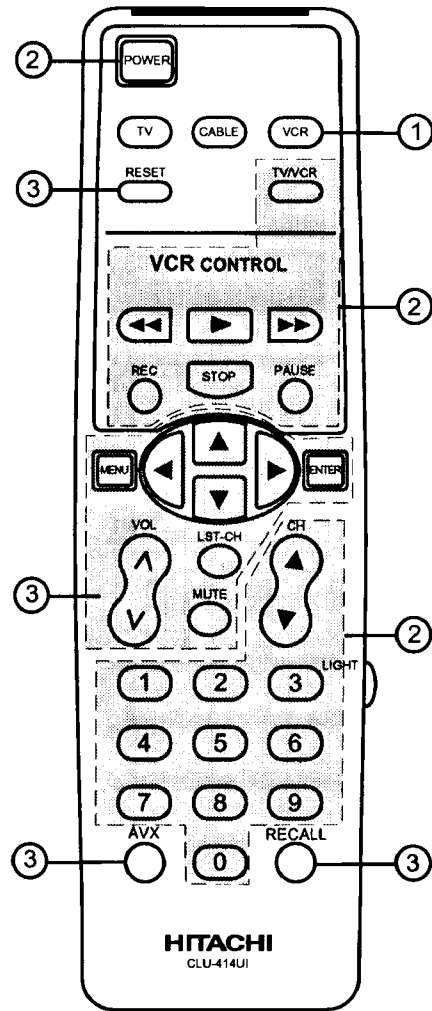
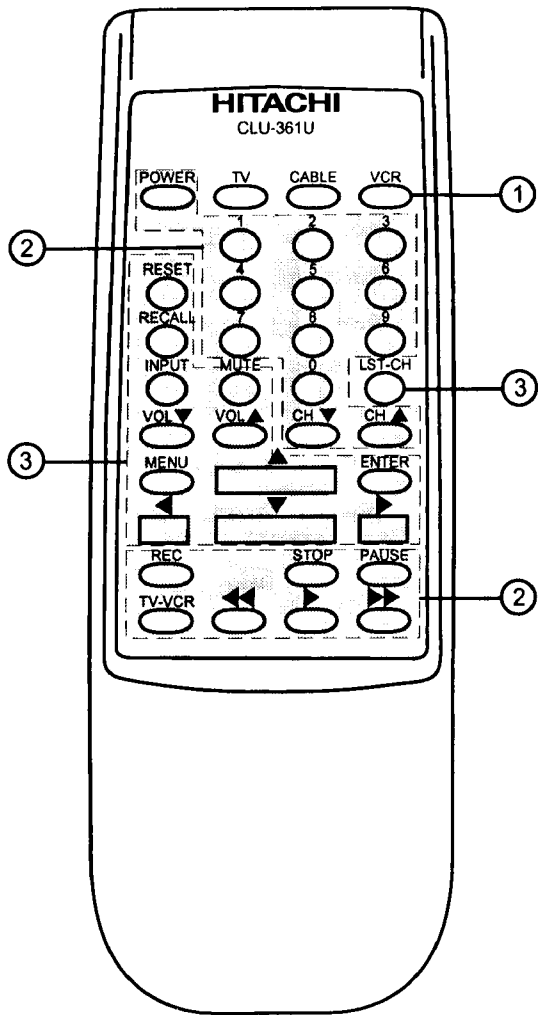

USING THE REMOTE TO CONTROL VCR FUNCTIONS



Operating the precoded function for your VCR

This remote is designed to operate different types of VCR's. You must first program the remote to match the remote system in your VCR. (Refer to pages 28.)

1. Turn on your VCR.
2. Aim the remote control at the front of your VCR.
3. Press the VCR button to switch to the VCR precoded mode.
4. While holding down the VCR button, enter the 2 digit preset code that matches your VCR as shown on page 28. The remote will turn off your VCR when the correct 2 digit preset code is entered. When this occurs, the remote control is programmed for your VCR. If the VCR does not turn off after 5 seconds, try a different 2 digit preset code.
5. The remote will now control your VCR.

NOTES:

1. If your VCR cannot be operated after performing the above procedures, this means that your VCR's codes have not been precoded into the remote.
2. In the unlikely event that your VCR cannot be operated after performing the above procedures, consult your VCR operating guide.
3. The remote control will remember the codes you have programmed in until the batteries are removed from the remote control. After replacing the batteries repeat the entire programming procedure stated above.
4. If your VCR does not have a power function, the remote will issue the CHANNEL UP function.

① VCR BUTTON

This allows the remote to control your VCR by setting it to VCR mode.

② PRECODED VCR BUTTONS

These buttons transmit the chosen precoded VCR codes. For some VCR's, you must press the RECORD button twice to record a program.

③ EXCLUSIVE TV BUTTONS

These buttons are for operating the TV.

NOTE: Refer to the instruction manual of the VCR for operation of the buttons exclusively for the VCR.



USING THE REMOTE TO CONTROL CABLE BOX FUNCTIONS

A detailed explanation of the circled numbers is on the following pages. (Example: ①).

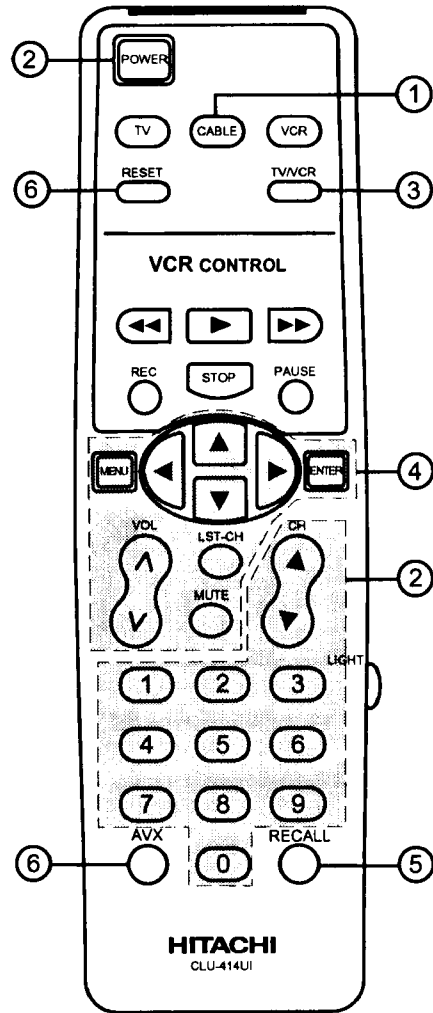
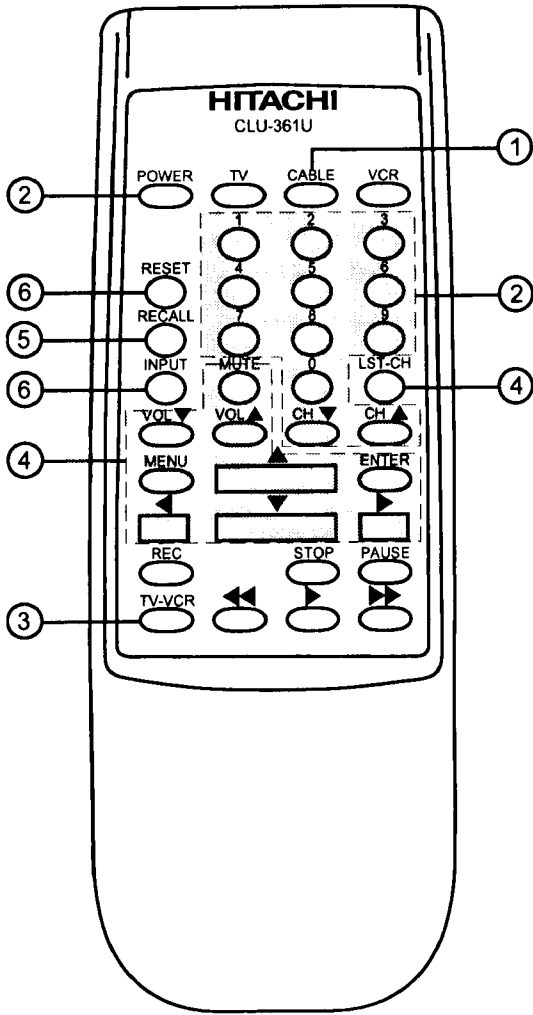

USING THE REMOTE TO CONTROL CABLE BOX FUNCTIONS



Operating the precoded function for your cable box

This remote is designed to operate different types of Cable Boxes. You must first program the remote to match the remote system in your cable box. (Refer to pages 28.)

1. Turn on your cable box.
2. Aim the remote control at the front of your cable box.
3. Press the cable box button to switch to the cable box precoded mode.
4. While holding down the CABLE button, enter the 2 digit preset code that matches your cable box as shown on page 28. The remote will turn off your cable box when the correct 2 digit preset code is entered. When this occurs, the remote control is programmed for your cable box. If the cable box does not turn off after 5 seconds, try a different 2 digit preset code.
5. The remote will now control your cable box.

NOTES:

1. If your cable box cannot be operated after performing the above procedures, this means that your cable box codes have not been precoded into the remote.
2. In the unlikely event that your cable box cannot be operated after performing the above procedures, consult your cable box operating guide.
3. The remote control will remember the codes you have programmed in until the batteries are removed from the remote control. After replacing the batteries repeat the entire programming procedure stated above.
4. If your cable box does not have a power function, the remote will issue the CHANNEL UP function.
5. For CLU-361U remote control only, channel ▲, ▼ will control the cable box channel. The number buttons will control your television channel although your in Cable mode.

① CABLE BUTTON

This button allows the remote to control your cable box by setting it to CABLE mode.

② PRECODED CABLE BOX BUTTONS

These buttons transmit the chosen precoded CATV codes.

③ TV/VCR BUTTON

When the remote is in CABLE mode, this is the A/B button.

④ ENTER BUTTON

If your cable box does not have an enter function, this button will send the TV enter code.

⑤ RECALL BUTTON

If your cable box does not have a last channel function, this button will send the TV channel recall code.

⑥ EXCLUSIVE TV BUTTONS

These buttons are for operating the TV.



VCR AND CABLE BOX CODES FOR CLU-414UI and CLU-361U

VCR BRAND (CLU-414UI)	CODE	VCR BRAND (CLU-414UI Cont.)	CODE	CABLE BRAND (CLU-414UI)	CODE	VCR BRAND (CLU-361U)	CODE
Adventura	00	Olympus	09	ABC	03,05,09,11,12,14	Emerson	00, 01, 10, 16, 23, 33, 37, 40, 43
Aiko	50	Optimus	20	Archer	40	Funai	00
Aiwa	00	Panasonic	09,35,46	Belcor	31	GE	09, 22
Akai	14,23	Penney	09,10,11,13,15,48	Cable Star	31	Hitachi	00, 14, 15
American High	09	Pentax	15,24	Century	40	JVC	14, 26
Asha	48	Philco	09	Citizen	40	Magnovox	0-9, 12, 28
Audiovox	10	Philips	09,28	Contec	15	Mitsubishi	16, 23, 26, 45
Beaumarck	48	Pilot	10	Garrard	40	Panasonic	09, 35, 46
Bell & Howell	30	Pioneer	26	GC Electronics	31	RCA	15
Brandt	38	Protoc	27	Gemini	13	Sony	06, 07, 08, 09
Broksonic	33,37,43	Pulsar	12	General Instrument	09	Toshiba	16, 17, 42
Canon	09	Quartz	18	Hamlin	08,16,49,50	Zenith	07, 08, 12
Carver	28	Quasar	09	Hitachi	09		
CCE	27,50	Radio Shack	00,10	Hytex	05		
Citizen	50	RCA	15,22,24	Jasco	40	CABLE BRAND	CODE
Colt	27	Realistic	00,09,10,18,19, 20,30,48	Jerrold	03,09,10,12,13	(CLU-361U)	
Craig	19,27,48	Ricoh	08	Memorex	00	GI	09
Curtis Mathes	09	Runco	12	Movie Time	42	Jerrold	03, 09, 10, 12, 13, 51
Cybermex	48	Samsung	17,48	NSC	42	Magnavox	40
Daewoo	17,50	Sanky	12,20	Oak	05,15,47	Phillips	40
Dynatech	00	Sansui	14,26	Panasonic	17	Pioneer	39
Emerex	06	Sanyo	18,19,30,48	Paragon	00	Samsung	39
Emerson	00,01,10,16, 23, 33,37,40,43	Scott	16,17,33,37,42,43	Philips	40	Scientific-Atlanta	04, 06, 14, 52, 56
Fisher	19,30	Sears	09,10,15,18,19,31	Pioneer	39	Zenith	00
Fuji	07,09	Sharp	20	Pulsar	00		
Funai	00	Shintom	27	RCA	17		
Garrard	00	Shogun	48	Regal	16,49,50		
GE	09,22,24	Singer	27	Rembrant	09		
Goldstar	10,11	Sony	06,07,08,09	Runco	00		
Gradiente	00	STS	15	Samsung	39		
Harley Davidson	00	Sylvania	00,09,16,28	Scientific Atlanta	04,06,14,52		
Harman/ Kardon	11	Symphonic	00	Signal	13		
Harwood	27	Tatung	14	Signature	09		
HI-Q	19	Teac	00,14	Sprucer	17		
Hitachi	00,15,24	Technics	09,35	Standard Components	41		
Jensen	14	Teknika	00,09,10	Starcom	03,13		
JVC	14,26	TMK	40,48	Stargate	13		
Kenwood	11,14,18,26	Toshiba	16,17,44	Starquest	13		
KLH	27	Totevision	10,48	Tocom	10,11,33		
Kodak	09	Unitech	48	Toshiba	00		
Lloyd	00	Vector	17	Tusa	13		
Logik	27	Vector Research	11,13	Unika	40		
LXI	10	Video Concepts	13,17,23	United Artists	05		
Magnavox	09,12,28	Videosonic	48	United Cable	03		
Magnin	48	Wards	00,09,15,19,20,27,48	Universal	31,40		
Marantz	09,11,28	XR-1000	27	Videoway	48		
Marta	10	XR 1000	00,09	Zenith	00		
Matsushita	09	Yamaha	11,14				
MEI	09	Zenith	07,08,12				
Memorex	00,09,10,12,18, 19,20,30,48						
MGA	16,23						
MGN Technology	48						
Minolta	15						
Mitsubishi	16,23,26,45						
Motorola	09,20						
MTC	00,48						
Multitech	00,27						
NEC	11,13,14,26						
Nikko	10						
Noblex	48						

EASY GRAPHIC GUIDE



1. Press MENU on the remote control to display the different features on your HITACHI TV. The feature to be selected will be highlighted in a yellow.

2. Press the CURSOR buttons to highlight a different feature.

3. Press ENTER on the remote control to select a feature.

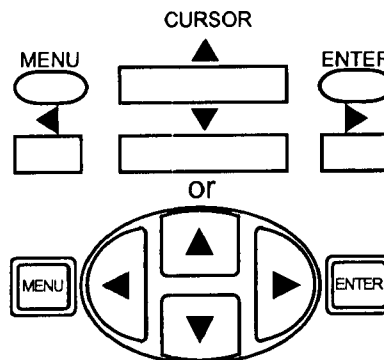

This part of the screen shows what selections are available.

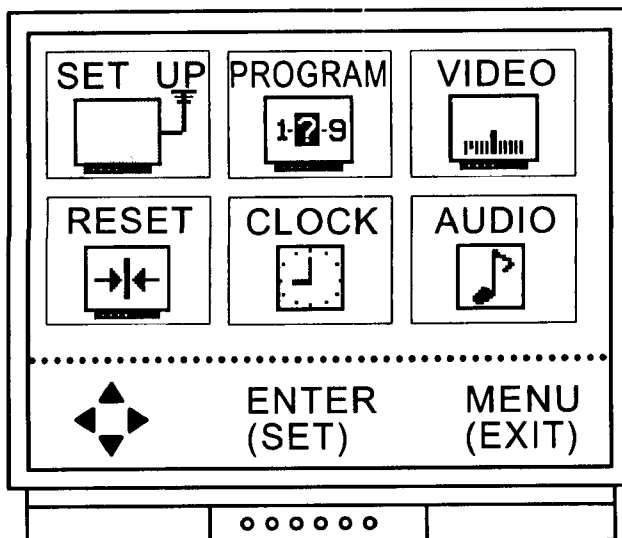

This part of the screen shows which remote control buttons to use.





EASY GRAPHIC GUIDE

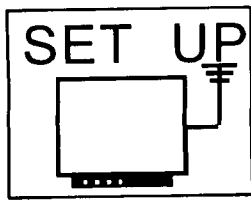

AIR/CABLE AIR

Select antenna or cable TV.

AUTO PROGRAM

First time setup for channel buttons.

CHANNEL MEMORY

Channel buttons, add or erase.

CLOSED CAPTION

Feature to display dialogue/text.

MENU LANGUAGE

Choose English, French, or Spanish Language.

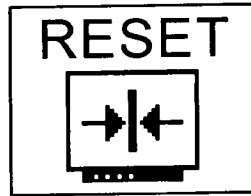

Return video and audio adjustments to factory settings.

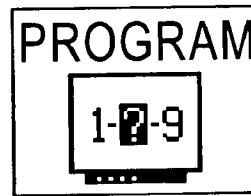

CHANNEL CAPTION

Label channels PAY1, ABC, etc.

CHILD LOCK

Block channel picture & sound.

PROGRAM LIST

Check channel name, scan, childlock.

VOLUME CORRECTION

Lower volume on selected channels.

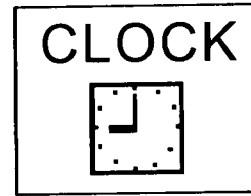

CLOCK SET

Set before using timer features.

ON/OFF TIMER

Turn TV on or off one time or daily.

MESSAGE

Set for one time or daily.

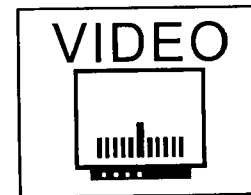

Adjust Contrast, Color, Tint, Brightness, Sharpness and White Control.

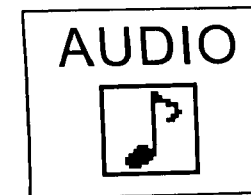

PREFERENCE ADJUST

Adjust balance, bass, and treble.

PREFERENCE SETTING

Improve sound performance.

SET UP

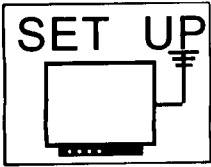

Select SET UP when setting your TV up for the first time. Use the CURSOR UP/DOWN buttons on the remote to highlight the function desired.

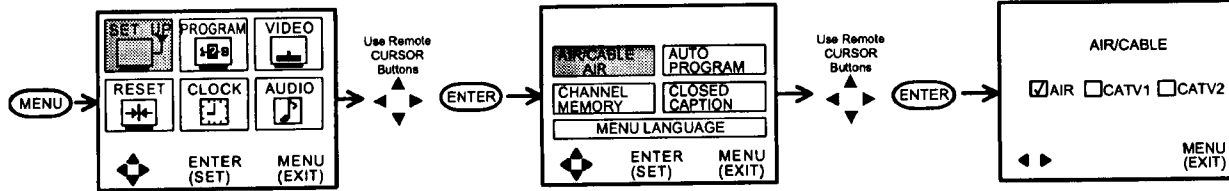

AIR/CABLE AIR

Select AIR if you are using an indoor or outdoor antenna. Select CATV if you have cable TV.

Press the CURSOR buttons to highlight the correct AIR/CABLE mode and press MENU to exit. Your choice will be shown on the display.

Your selection is shown here

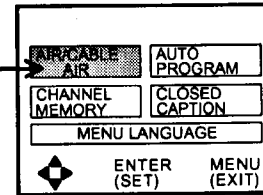

RECEPTION BAND		
AIR	CATV 1 or CATV 2	
	CATV CHANNEL	Indicated on the screen
VHF 2 ~ 13ch UHF 14 ~ 69ch	VHF 2 ~ 13	2 ~ 13
	MID band A ~ I A-5 ~ A-1	14 ~ 22 95 ~ 99
	Super band J ~ W	23 ~ 36
	Hyper band W + 1 ~ W + 28	37 ~ 64
	Ultra band W + 29 ~ W + 84	65 ~ 125

Reception channels for each mode are shown at the left.

Refer to your cable or TV guide for channel identification standards.

If certain CATV channels are poor or not possible in the CATV1 mode, set AIR/CABLE to CATV2.

AUTO PROGRAM

This feature will automatically store active TV channels in CHANNEL MEMORY. This will allow you to skip over unused channels when using the CHANNEL UP (▲) or DOWN (▼) buttons.

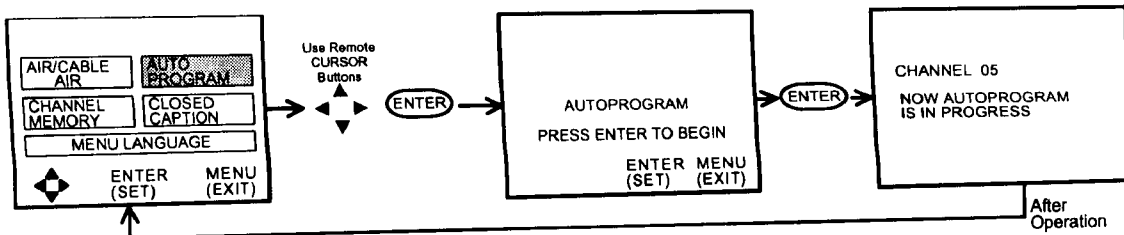

If the MENU button is pressed while the auto programming function is engaged, programming will stop.

See CHANNEL MEMORY to add or erase additional channels.



SET UP

CHANNEL MEMORY

Use this function after AUTOPROGRAM to add or erase additional channels to the remote control CHANNEL ▲, ▼ buttons. Your choice will be highlighted in red.

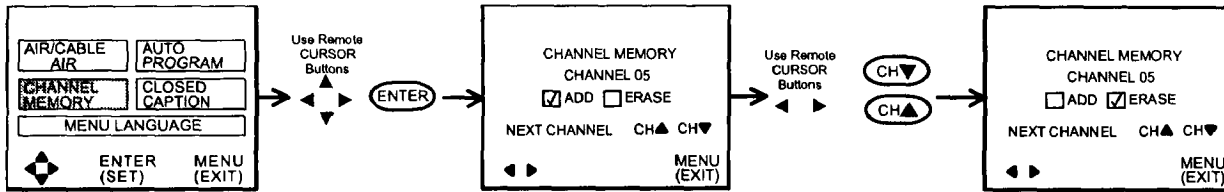

Add or erase additional channels while still in CHANNEL MEMORY using the CHANNEL ▲, ▼ buttons or number buttons and then add or erase using the CURSOR ◀, ▶ buttons.

CLOSED CAPTION

Closed captions are the dialogue, narration, and/or sound effects of a television program or home video which are displayed on the TV screen. Your local TV program guide denotes these programs as **CC** or

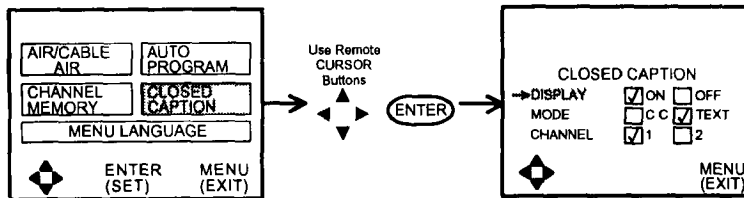

The selected function will be yellow. Your choice for the function will be red.

DISPLAY: ON/OFF is to turn the display on or off.

MODE: C.C. (Closed Caption) is for the program you are viewing.

MODE: TEXT is for additional information such as news reports or a TV program guide. This information covers the entire screen and viewing the TV program is not possible. TEXT may not be available with every program.

CHANNEL: 1 is used for the primary language (usually English).

CHANNEL: 2 is sometimes used for a second language (may vary by region).

Use the CURSOR ▲ or ▼ to highlight the function to change, press ENTER to change the function, and press MENU to exit.



MODE: C.C.

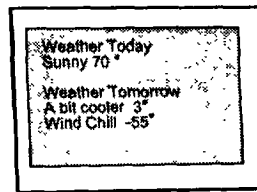

MODE: TEXT

NOTE: The word MUTE will not be displayed if the DISPLAY is ON. If you do not have sound, make sure MUTE is not set.



SET UP

MENU LANGUAGE

This feature will allow you to select any one of 3 different languages for all on screen displays.

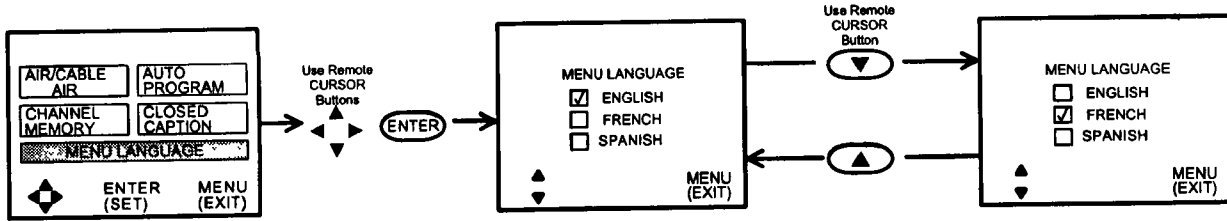

Use the CURSOR ▲, ▼ buttons to select the MENU LANGUAGE of your choice.

Press MENU to exit.



RESET

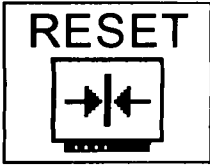

Use the reset to change your preferred video and audio adjustments to factory settings.

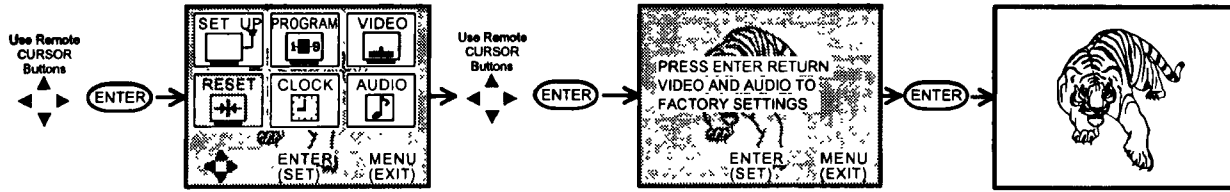

Factory Settings:

VIDEO

Contrast: ██████████
 Color: ██████████
 Tint: ██████████
 Brightness: ██████████
 Sharpness: ██████████
 White Control: COOL

AUDIO

Balance: ██████████
 Bass: ██████████
 Treble: ██████████
 MTS Mode: STEREO
 Loudness: OFF
 Internal Speakers: ON

NOTE: This RESET Selection will not change your preferred adjustments. To change back to your adjustments, see VIDEO (page 40) or Audio (page 41).



PROGRAM

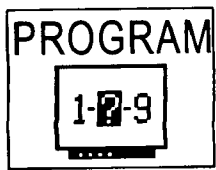

This selection contains advanced features which will make TV viewing easier and more enjoyable.

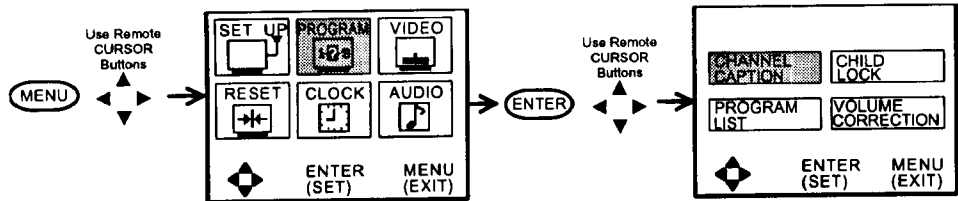

CHANNEL CAPTION

Use this feature to give up to 30 channels a name.

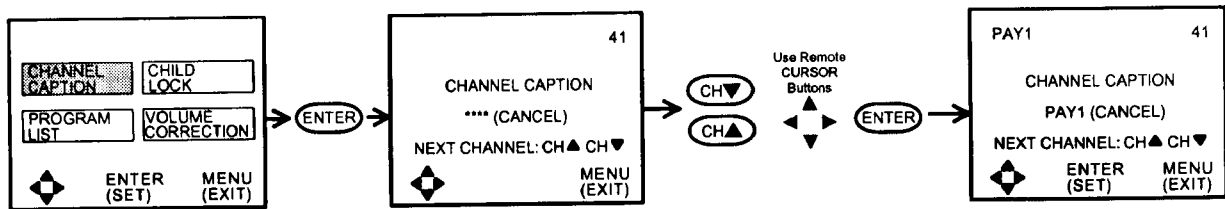

Press the CURSOR ▲, ▼ to select letters.

Press the CURSOR ◀, ▶ to change position.

Press ENTER to set the CHANNEL CAPTION and it will appear in the top left corner of the screen.

Press CHANNEL ▲, ▼ or the number buttons to select additional channels for labeling.

Press MENU to exit.

The (*) represents a blank space.

Select CANCEL to erase a CHANNEL CAPTION.

PROGRAM LIST

This function allows you to view which channels are labeled CHANNEL CAPTION (NAME), which have been added to CHANNEL MEMORY (SCAN), and are protected by CHILD LOCK (LOCK).

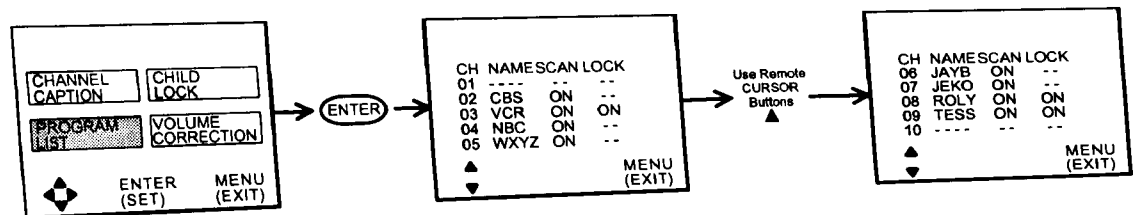

Press CURSOR ▲, ▼ to review more channels.
Press MENU to EXIT.

CHILD
LOCK

This function will block out the picture and sound of the selected channel.

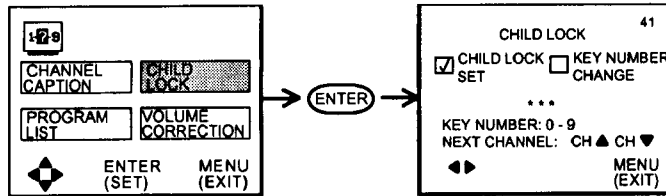

The code to set or cancel CHILD LOCK is a three digit key number. The factory preset key number is 000.

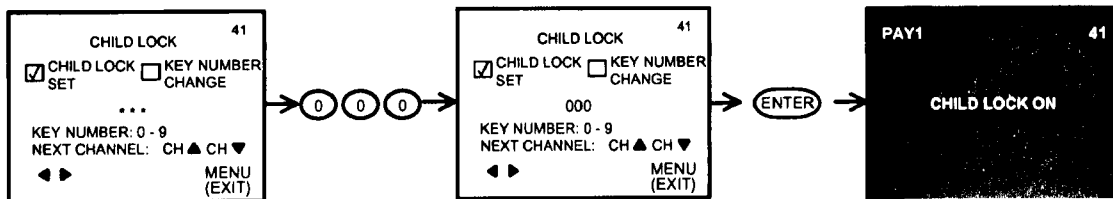

The picture and sound will now be blocked out for this channel. Repeat the same steps to cancel the CHILD LOCK.

To change the key number, select key number change. Enter the old number (factory preset 000 for first time use), then enter a new three digit key number you prefer.

If you forget your key number, use the factory code 777 to erase your key number. This resets the key number back to the factory preset.

PROGRAM



VOLUME CORRECTION

Use this function to reduce the volume level of up to four TV channels that sound loud compared to other TV channels.

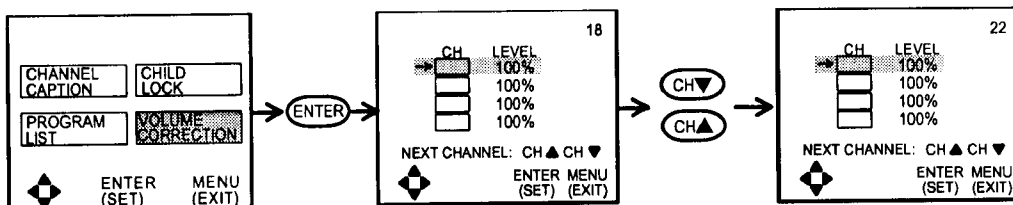

Press the CURSOR ▲, ▼ to select one of the four volume corrections.
Use the CHANNEL ▲, ▼ or number buttons to select a channel.

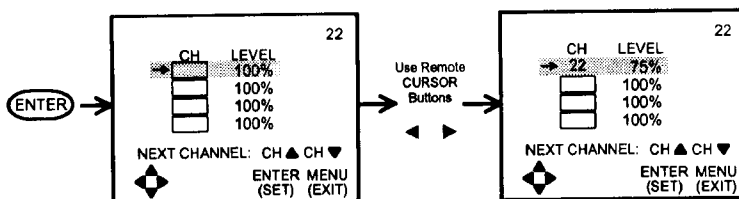

Press ENTER to set the channel.
Press CURSOR ◀, ▶ to adjust volume level.
Press MENU to exit.

- NOTE:**
1. VOLUME CORRECTION adjustment is for the channel displayed in the top right corner of the screen. To adjust a different channel, you must select the channel with the channel or number buttons and press ENTER.
 2. If the channel has been corrected before, use the cursor ▲, ▼ to highlight that channel then use the cursor ◀, ▶ to change the level.
 3. To erase a channel from the volume correction, select channel 00 and press ENTER.
 4. The volume level will change from 50% to 100% in increments of 5%.



CLOCK

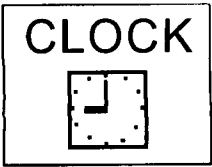

Use this feature for all time related functions.



The time must be set before you can use the ON/OFF TIMER or AUTOMATIC MESSAGE.

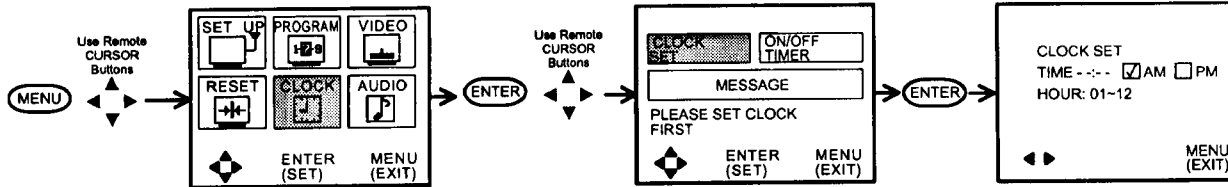

Use the number buttons and CURSOR , to set the time.
 The AM or PM selected will be highlighted in red.
 When you have finished setting the time, press ENTER to start.



This function will automatically turn the TV on or off, one time only or everyday.

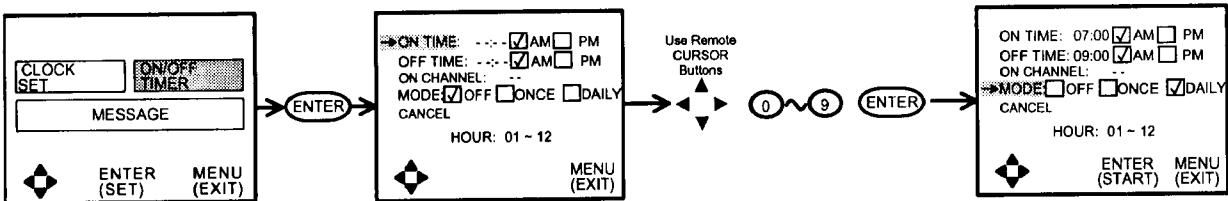

The selection to change will be in yellow.
 Press the number buttons to select the time the TV will turn on or off. (AM: 1, PM: 2)
 Press the CURSOR , buttons for MODE: ONCE (one time only) or MODE: DAILY (TV will turn on/off at the same time every day).
 Press CHANNEL , or the number buttons to set the channel the TV will tune to when it automatically turns on.

Your choice for AM/PM and MODE will appear in red.
 Press ENTER to start.
 Select CANCEL and press ENTER to erase times.

NOTE: You can set either on time only, off time only, or both. The mode will be the same for both.

CAUTION: Do not use your TV as a deterrent when away from home by using both the ON and OFF TIMERS. For safety, the TV should be turned off when you are away from home.

CLOCK



AUTOMATIC MESSAGE

The message function allows the user to program messages of up to 31 characters in the TV's memory. The user can program the message to appear every day or one time only.

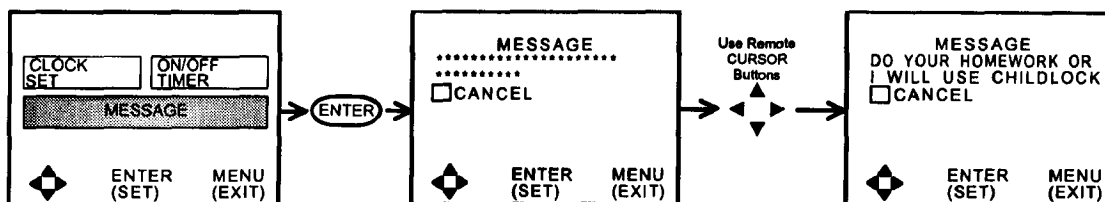

Use the CURSOR ▲, ▼ to select a letter or other character.

Use the CURSOR ◀, ▶ to change position.

Press ENTER when message is finished.

The asterisk (*) represents a blank space.

Move the CURSOR ◀, ▶ until (CANCEL) is yellow and press ENTER to erase message.

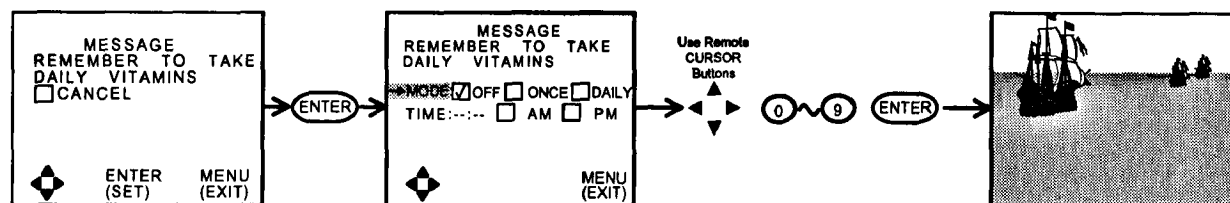

Use CURSOR ▲, ▼ to choose MODE or TIME.

Use CURSOR ◀, ▶ to set MODE when it is yellow. Your choice will be in red.

Use the NUMBER buttons to set the time.

Press ENTER to start and MENU to exit.

NOTE: When the scheduled time for the message arrives, the TV will beep 5 times and the message will be displayed. If you do not wish to wait for the 5 beeps, press a remote button anytime during the 5 beeps. The beeping will stop and the message will be displayed.

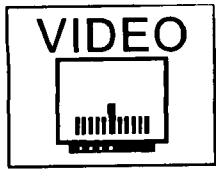

Select VIDEO to adjust picture settings, and to improve picture quality.

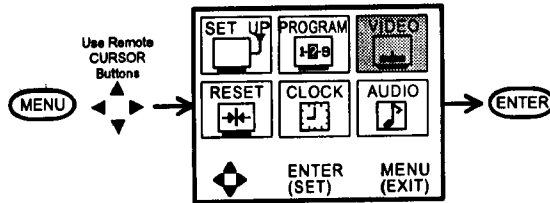

Use this feature to adjust contrast, color, tint, brightness, sharpness, and white control.

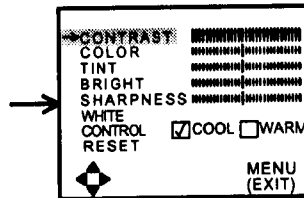

Press the CURSOR buttons to select and make adjustments.
The function to be adjusted will be in yellow.

CONTRAST- Use this function to change the contrast between black and white level in the picture.

COLOR- Use this function to adjust the level of color in the picture.

TINT- Use this function to adjust flesh tones so they appear natural.

BRIGHT- Use this function to adjust overall picture brightness.

SHARPNESS- Use this function to adjust the amount of fine detail in the picture.

WHITE CONTROL- Use this function to adjust the white balance (hue) of the picture to your own color preference.
When shipped from the factory, this is set to: "COOL". If you prefer a reddish screen, set to "WARM".

RESET- When RESET is selected, press ENTER to return video adjustments to factory preset conditions.

AUDIO



Select AUDIO to adjust the TV to your preference, to improve the sound quality, and to select special sound effects. Model 20SA5B does not have preference adjustment option.

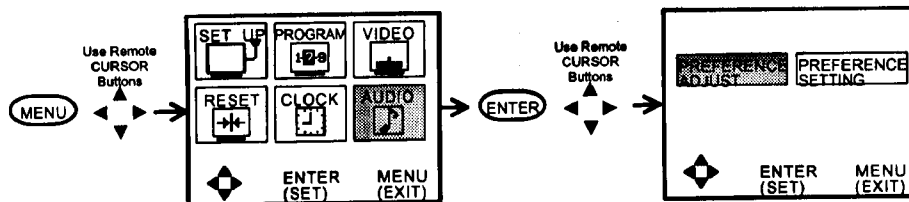

PREFERENCE ADJUSTMENT

Use this to set balance, bass, and treble.

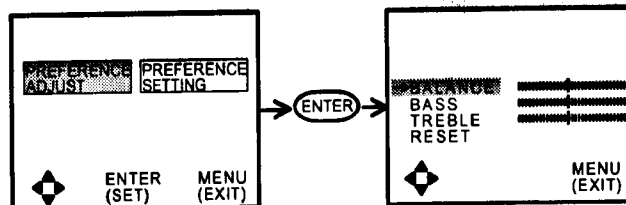

Press the CURSOR buttons to select and make adjustments. The function to be adjusted will be in yellow.

BALANCE- This function will control the left to right balance of the TV internal speakers, the AUDIO TO HI-FI output, and the surround speakers.

BASS- This function controls the low frequency audio to all speakers.

TREBLE- This function controls the high frequency audio to all speakers.

RESET- When RESET is selected, press ENTER to return audio adjustments to factory preset conditions.



AUDIO

PREFERENCE SETTING

Use PREFERENCE SETTING to improve the sound performance of your TV depending on listening conditions.

27CX1B, 27CX15B

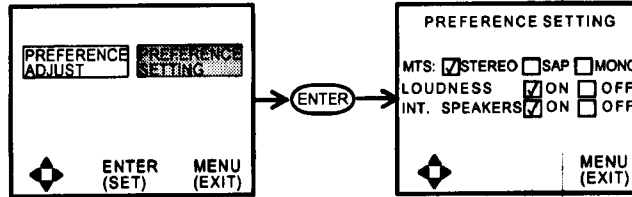

20SA5B

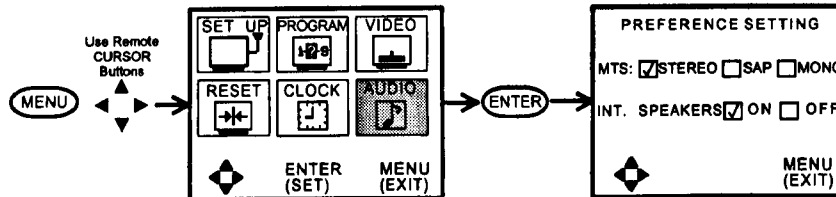

Use the CURSOR ▲, ▼ to select a function. The function will be in yellow.
Use the CURSOR ◀, ▶ to change function. Your choice will be in red.

MTS MODE (Multi-Channel Television Sound) will allow you to select STEREO (a stereo broadcast), SAP (second audio program) which may be a secondary language, weather report, etc. or MONO (monaural sound) used when receiving a weak stereo broadcast.

The sources received will be displayed below the channel number. The source you select will be displayed to the left of the channel number. See example below for each selection when both stereo and second audio are received (monaural is always received).



LOUDNESS

This function will improve the quality of both low and high frequency sounds when listening at low volume levels.

INT. SPEAKERS

This function is useful if you prefer to use only speakers from a separate stereo system.

CARE OF YOUR HITACHI COLOR TV AND YOUR REMOTE CONTROL



DO

Make sure the TV is turned off when cleaning the screen.

Dust the screen and cabinet with a soft cloth.

Clean the screen with a soft cloth moistened in warm water. Dry with a soft cloth. (A mild soap may be used if the screen is extremely dirty.)

Place your TV and remote control away from extreme heat, humidity and extremely dusty places.

Remove the plug from the wall outlet if your television set will not be used for a long period of time, for instance, when you go on vacation.

DO NOT

Do not clean your screen or cabinet with strong cleaners, polishes or a chemically treated cloth.

Do not place rubber or vinyl products or cellophane tape on your set.

Do not touch the screen too often.





Do not subject the Remote Control to shocks such as dropping it on the floor, etc. Physical damage to the precision parts may result.

Avoid placing the Remote Control in a high humidity place or getting it wet. Don't leave it on or near a heater. Excessive heat or moisture may cause the unit to cease operation.

When the batteries run down, remote control operation will become erratic or possibly stop altogether. Replace the old batteries with fresh "AA" size batteries.



RECEPTION PROBLEMS

	<p>• IGNITION NOISE: Black spots or horizontal streaks may appear, picture may flutter or drift. Usually caused by interference from automobile ignition systems, neon lamps, electrical drills and other electrical appliances.</p>
	<p>• GHOSTS: Ghosts are caused by the television signal following two paths. One is the direct path and the other is reflected from tall buildings, hills or other objects. Changing the direction or position of the antenna may improve reception. Ghosting may also be caused by defects in the antenna system such as unshielded leads or connecting several sets to the same antenna without using multiple antenna couplers.</p>
	<p>• SNOW: If your receiver is located in the fringe area of a television station where the signal is weak, your picture may be marred by the appearance of small dots. When the signal is extremely weak, it may be necessary to install a special antenna to improve the picture.</p>
	<p>• RADIO FREQUENCY INTERFERENCE: The interference produces moving ripples or diagonal streaks, and in some cases, causes loss of contrast in the picture.</p>

CHECK HERE BEFORE CALLING FOR SERVICE



SYMPTOMS	CHECK THESE ITEMS AND TRY THESE ADJUSTMENTS											
	Be sure external connection is correct	Be sure power cord is plugged in	Be sure TV is switched "ON"	Try another channel (station trouble)	Check antenna connections (back of TV)	Check antenna for broken lead-in wire	Check for local interference	Adjust Contrast control	Adjust Brightness control	Adjust Color control	Adjust Tint control	Adjust Volume control
No picture, no sound	●	●	●	●	●	●	●					
Sound OK, picture poor	●			●	●	●	●	●	●			
Picture OK, sound poor	●			●	●	●	●	●				●
Picture blurred	●			●	●	●	●	●				
Lines or streaks in picture				●	●	●	●	●				
Poor reception on some channels				●	●	●	●	●				
Picture rolls vertically				●				●				
No Color	●			●	●	●	●			●		
Poor color	●			●	●	●	●			●	●	



SPECIFICATIONS

Features:

- Superfine Picture Quality
600 Line Horizontal Resolution for (27CX1B, 27CX15B)
- Dart Tint CPT
- Remote Transmitter
(Controls many VCR and Cable Box brands)
- ICONS: Easy Graphics Guide
- Full set of Input Jacks, including S-Video (27CX1B and 27CX15B)
- Closed Caption Decoder
- Comb Filter, Wide-Band Video-Amp (27CX1B and 27CX15B)
- MTS (Multi-Channel Television Sound) Stereo Broadcast Reception.

Screen Size: 27V (27 inches measured diagonally) 27CX1B and 27CX15B
20V (20 inches measured diagonally) 20SA5B

Inputs:

- Power Input AC 120V, 60 Hz
- Power consumption (operating)
 - 27CX1B, 27CX15B 107W
 - 20SA5B 92W
- Power consumption (maximum)
 - 27CX1B, 27CX15B 142W
 - 20SA5B 115W
- Antenna input impedance 75 Ohm
- Channel coverage 181 ch.
 - VHF-Band 2~13
 - UHF-Band 14~69
 - CATV Mid Band A-5~A-1
A-1
 - Super Band J-W
 - Hyper Band W+1-W+28
 - Ultra Band W+29-W+84
- Video 1.0Vp-p, 75 Ohm
- S-Video
 - Luminance (Y) 1.0Vp-p, 75 Ohm
 - Chrominance (C) 0.286Vp-p, 75 Ohm
- Audio input impedance 47k Ohm
- Average input level 470mVrms
- Maximum input level 940mVrms

Dimensions:

	20SA5B	27CX1B 27CX15B
• Height (in.)...	17 ⁷ / ₈	23 ¹ / ₃₂
• Width (in.)...	20 ¹ / ₄	27 ¹ / ₄
• Depth (in.)...	18 ³ / ₄	20 ³ / ₁₆
• Weight (lbs.)...	46	88

NOTE: Due to improvements, specifications in this operating guide are subject to change without notice.



HITACHI

*Service
hotline*

To locate an authorized
HITACHI service facility
in the continental U.S.A.
and Canada,

DIAL TOLL FREE

7 days a week, 24 hours a day

800 HITACHI

1-800-448-2244

Hitachi Home Electronics (America), Inc.

Hitachi has made every effort to assure you hours of trouble free operation from your unit. However, should you require service, a network of Hitachi Authorized Service Facilities has been established in all 50 states and Puerto Rico. Each facility will provide you with convenient and expedient assistance. Our service "Hotline" operator will direct you to the Hitachi Authorized Service Facility nearest you. Just present proof of purchase and/or delivery receipts to the Hitachi Authorized Service Facility, and service will be rendered in accordance with the terms of the limited warranty as stated on your warranty card or operating guide.

Should you have any questions regarding in-warranty service, operation or technical assistance, please contact:

Hitachi Home Electronics(America), Inc.
3890 Steve Reynolds Blvd.
Norcross, GA 30093
Tel: 770-279-5600

Hitachi Sales Corporation of Hawaii
3219 Koapaka St.
Honolulu, HI 96819
Tel: 808-836-3621

For TV's purchased in Canada only, please contact one of the Hitachi offices below, should you have any questions regarding service, operation or technical assistance.

MONTREAL
9425 Trans Canada
Saint-Laurent, Quebec
H4S 1V3

Tel: (514) 956-9882
Fax: (514) 956-9761

TORONTO
6740 Campobello Road
Mississauga, Ontario
L5N 2L8

Tel: (905) 821-4545
Fax: (905) 826-6627

VANCOUVER
54 Humber Place, Annacis Industrial Estate
New Westminster, B.C.
V3M 6A6

Tel: (604) 526-8566
FAX: (604) 526-8127

HITACHI