PROSCAN

USER MANUAL

SAFETY INFORMATION

WARNING

RISK OF ELECTRIC SHOCK
DO NOT OPEN

TO REDUCE THE RISK OF ELECTRIC SHOCK, DO NOT REMOVE COVER (OR BACK). NO USER SERVICEABLE PARTS INSIDE. REFER SERVICING TO QUALIFIED SERVICE PERSONNEL.



This symbol indicates "dangerous voltage" inside the product that presents a risk of electric shock or personal injury.



This symbol indicates important instructions accompanying the product.

WARNING

To reduce fire or shock hazard, do not expose this TV to rain or moisture.

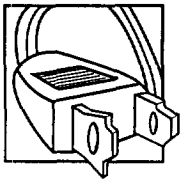

Caution: To reduce the risk of electric shock, match wide blade of plug to wide slot, fully insert.

Attention: Pour éviter les chocs électriques, introduire la lame la plus large de la fiche dans la borne correspondante de la prise et pousser jusqu'au fond.

Do not defeat the safety feature of the plug. The wide blade fits into the wall socket only one way. If you need an extension cord, make sure it matches the plug of the TV.

Operate TV only on 120 volts, 60 Hz AC power (normal house power).

FCC Regulations state that unauthorized changes or modifications to this equipment may void the user's authority to operate it.

NOTE TO CABLE TV INSTALLER

This reminder is provided to call your attention to Article 820-40 of the National Electrical Code (Section 54 of the Canadian Electrical Code, Part 1) which provides guidelines for proper grounding and, in particular, specifies that the cable ground shall be connected to the grounding system of the building as close to the point of cable entry as practical.

PROSCAN[®]

SO ADVANCED. YET SO SIMPLE.™

We're building our reputation on products that are so advanced, they're simple. If you want all the benefits of the latest technology, without the complexity, we have a very simple solution.

It's called ProScan. State-of-the-art technology that real people can use.

Thank you for choosing ProScan. And welcome to our company-wide commitment to your complete satisfaction and viewing enjoyment.

QUICK REMOTE

TV OPERATION

1. Press TV to turn on the TV.
2. Press the CHAN buttons to change channels, or enter channels directly with the number buttons.
3. Press the VOL buttons to change the volume.

GETTING AROUND IN THE MENUS

1. Press MENU to bring up the Main Menu—a living room.

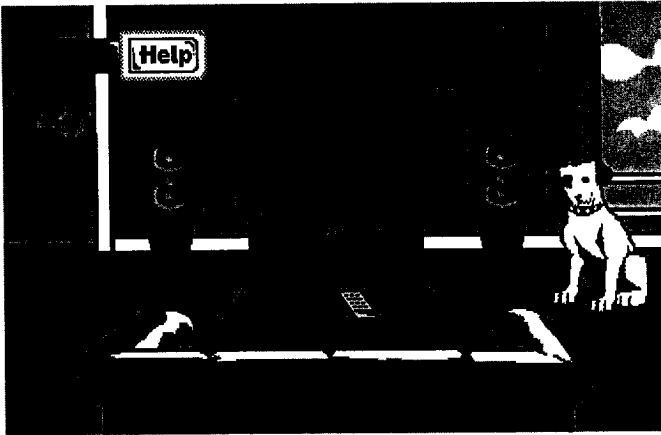

2. Use the MOVE arrows to point to an item in the living room.
3. Press MENU to enter the menu associated with that item.
4. Use the MOVE arrows to navigate around the menu, highlight menu items, and make adjustments.
5. Point to Exit and press MENU to return to the Main Menu.
6. Point to Exit and press MENU to return to normal viewing.

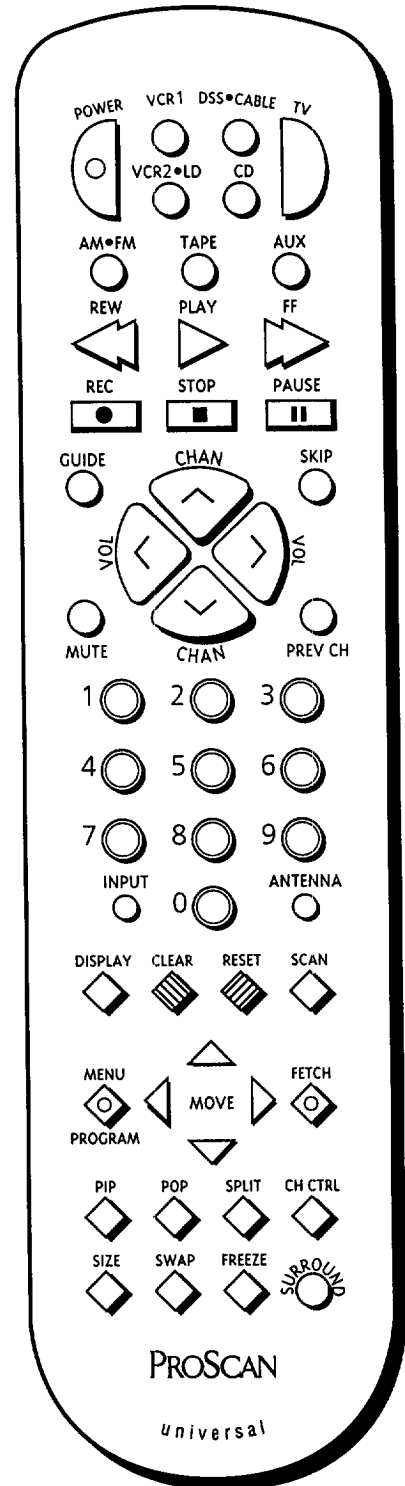

TABLE OF CONTENTS

First Things First.....	3
Using the Menu System	7
The Menu Rule: Point and Select	8
Menus and Control Panels	9
Interactive Setup.....	17
Entering the Interactive Setup	18
Connect the TV	19
Search for Channels	19
Set the Time	19
Edit the Channel Labels	20
Programming the Remotes	21
Programming the Universal Remote	22
To Control a VCR	22
To Control a DSS Receiver	24
To Control a Satellite Box	24
To Control a Cable Box	25
To Control a Laserdisc Player	26
To Control an Audio Component	26
Programming the Simple Remote	28
Using the Simple Remote to Control a Component	30
Tour of the TV	31
Remote Buttons	32
Simple Remote Buttons	34
Channel Marker	35
Back Panel	36
Front Panel	38
Quick Reference Guide	39
Audio Menu	40
Picture Quality Menu	42
Screen Menu	43
Time Menu	45
Channel Menu	46
Assistance	50
Advanced Features.....	51
PIX+ Operation	52
Two Tips for Using PIX+ Buttons	53
Closed Captioning	54
Adjusting Projection TV	56
On-screen Program Details	57
Choosing an Audio Processor	58
Using and Modifying Fetch	59
Displaying On-Screen Help	60

TABLE OF CONTENTS

Appendices	61
Things to Know Before Connecting Components	61
Appendix A: Connections	62
Connection A: TV Only	62
Connection B: TV and Mono VCR	63
Connection C: TV and Stereo VCR	64
Connection D: TV and Stereo VCR Using a Splitter	65
Connection E: TV and DSS Receiver	66
Connection F: TV, VCR and DSS Receiver	67
Connection G: TV, VCR and DSS Receiver Using a Splitter	68
Connection H: Adding a Laserdisc Player	70
Appendix B: Connecting External Speakers.....	71
Connecting External Speakers	71
Connecting Audio Components	72
Connecting a Camcorder for Playback.....	73
Connecting a Camcorder to Record from TV	74
Appendix C: Troubleshooting Tips	75
Appendix D: Limited Warranty	77
Appendix E: Care and Cleaning.....	78
Index	79
Accessories	Inside Back Cover

FIRST THINGS FIRST

ALLOW ME TO INTRODUCE MYSELF...

My name is Scott, and I wrote this **PROSCAN User Manual**. You probably weren't expecting a personal introduction, but then, a **PROSCAN TV** is designed to give you more than you expected—and that includes the **User Manual**.

AN 80-PAGE INSTRUCTION BOOK?

You used to be able to buy a TV, plug it in, stick some rabbit ears on top of it, and you were off and running. **Watching. Whatever.** Times have changed, though. But don't worry, it looks more complicated than it is.

YOU'VE NEVER SEEN ANYTHING LIKE IT...

I'll bet you've never seen anything like this TV. Don't believe me? Press the **MENU** button on the remote. That's the **Main Menu**. Times have definitely changed.

READ THE FIRST FOUR SECTIONS

The first four sections of the manual take you through the steps needed to set up the TV. The rest of the manual provides additional information that you can thumb through when you have the time or inclination. If you have a specific question, refer to the table of contents or the index.

1 FIRST THINGS FIRST



USING THE MENU SYSTEM

INTERACTIVE SETUP

PROGRAMMING THE REMOTE

The road map on the green intro pages is there to let you know where you are in the setup process.

FIRST THINGS FIRST

STEP 1: UNPACK THE TV AND ACCESSORIES

The accessories packed with TV include the Universal Remote, the Simple Remote, six AAA batteries, an antenna adapter, and an audio/video adapter for plugging your camcorder into the front of the TV. Be sure to locate the *Connections Foldout*.

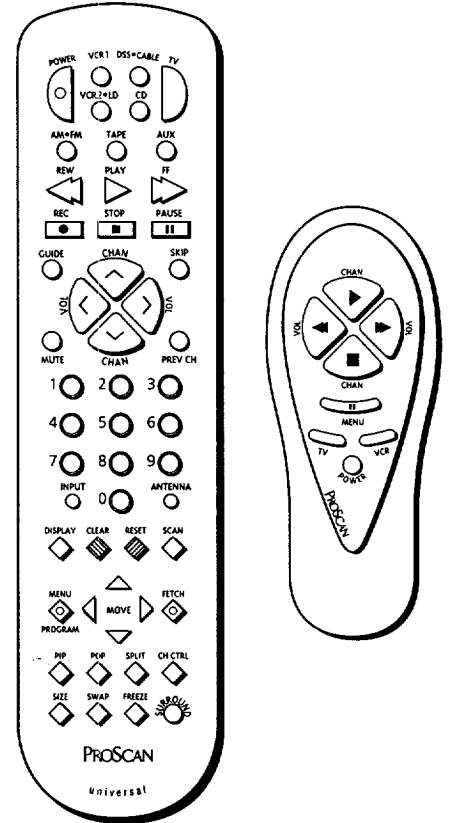

STEP 2: CONNECT YOUR TV

If you're only going to connect the TV to your home antenna or cable box, use the "TV Only" connection shown below. If you're going to connect the TV to a VCR, laser disc player or other component, skip to the top of the next page.

TV ONLY

This is a basic connection from an antenna or cable box to your TV. Connect the cable as shown. If you have a VCR or other components to connect to the TV, skip to the top of the next page.

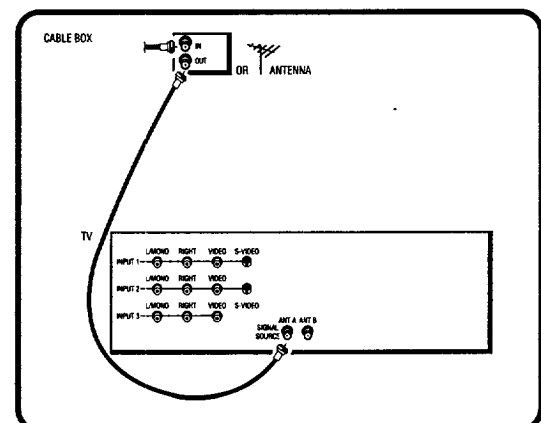

FIRST THINGS FIRST

TV WITH OTHER COMPONENTS

Use the *Connections Foldout* to connect your TV to a VCR, DSS™ receiver, or laserdisc player. See *Appendix A*, p. 62 for detailed information about using each of these connections. After connecting the TV, proceed to Step 3, below.

If your components don't match those shown on the Foldout, or if you prefer a different connection, see your dealer or the specific component user manuals.

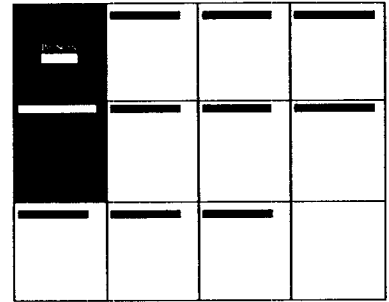

STEP 3: PLUG IN THE TV

Plug the power cord into the wall outlet, matching the wide blade of the plug with the wide slot in the outlet. Be sure to insert the plug completely.

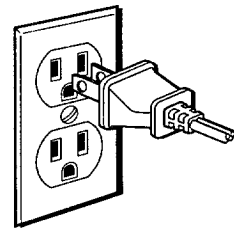

STEP 4: INSTALL BATTERIES

1. Slide the battery compartment cover off the back of the remote.
2. Insert the four AAA batteries as shown, matching the + and - ends of each battery in the compartment.
3. Replace the cover.
4. Repeat these directions to insert the two remaining AAA batteries into the simple remote.

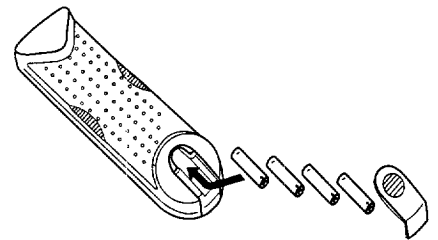

FIRST THINGS FIRST

STEP 5: TURN ON THE TV

Press TV on the remote, or press POWER on the TV itself.

STEP 6

Read the next section, *Using the Menu System*, which is a brief overview of the basic rules for getting around in the menus.

STEP 7

Proceed to section three, *Interactive Setup*. This setup routine walks you through the steps needed to fully configure the TV. Part two of the setup routine puts available cable TV or antenna signals into the TV's memory. This is called "auto channel search." **You must complete the auto channel search.** After you complete this step, you can skip any of the remaining steps and return to them later.

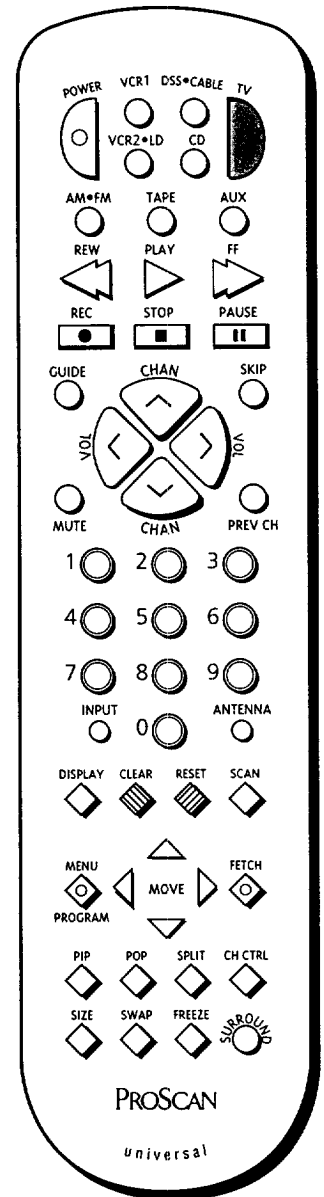

If the picture appears to have a double or triple image, you may have to adjust the color convergence. Details are on pages 44 and 56.

Interactive Setup is designed to be used with the Connections Foldout.

USING THE MENU SYSTEM

A LIVING ROOM IN MY LIVING ROOM?

You access the TV's features through an on-screen menu system. The first menu in the system looks like a living room, hence its name: the Living Room Main Menu. You use the Living Room Main Menu to get to other menus, such as the Audio menu.

FIRST THINGS FIRST

2 USING THE MENU SYSTEM



INTERACTIVE SETUP

PROGRAMMING THE REMOTE

Menu systems may be a necessary part of the TV software, but that doesn't mean that they can't be fun!

USING THE MENU SYSTEM

THE MENU RULE: POINT AND SELECT

You only need to know one rule to use the on-screen menus:
point and select.

WHAT IS POINT AND SELECT?

The point and select method has two steps.

1. **Point** to a menu item using the MOVE arrows on the remote.

To point up or down, press the up or down arrows. To point left or right, press the left or right arrows.

2. **Select** a menu item by pressing MENU.

Selecting an item tells the TV's menu system to go ahead and make a change or go to a place you have indicated.

For example, to select the Channel menu from the Main Menu:

1. Press MENU to bring up the Main Menu. The Main Menu looks like a Living Room.
2. Point to the picture of the remote control by pressing the down arrow until the word "Channel" appears.
3. Press MENU to select *Channel*. The Channel menu comes up.
4. Point to *Exit* and press MENU to return to the Main Menu.
5. Point to *Exit* and press MENU to leave the menu system and return to TV viewing.

Once you know how to point and select your way through the menus, you can apply this rule in the menus and the control panels that do the real work of the menu system.

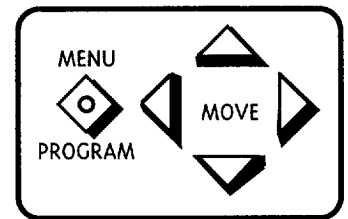

Press CLEAR at any time to remove all displays from the screen and return to TV viewing.

USING THE MENU SYSTEM

MENUS, CONTROLS AND CONTROL PANELS

There are three parts to the menu system: menus, controls, and control panels. Before you can use the controls and control panels to adjust your TV, you have to move through the Main Menu and select a control.

THE LIVING ROOM MAIN MENU

To bring up the Living Room Main Menu:

1. Press MENU on the remote or front panel.



The Living Room Main Menu contains eight items that you can select: six menus and two buttons. Let's take a look at the buttons first.

USING THE MENU SYSTEM

The Exit Button

All menus have an *Exit* button. Selecting the *Exit* button always takes you to the previous screen. Selecting the *Exit* button from the Main Menu returns you to regular TV viewing. For example,

1. Press MENU to bring up the Living Room Main Menu. Point to *Exit*.

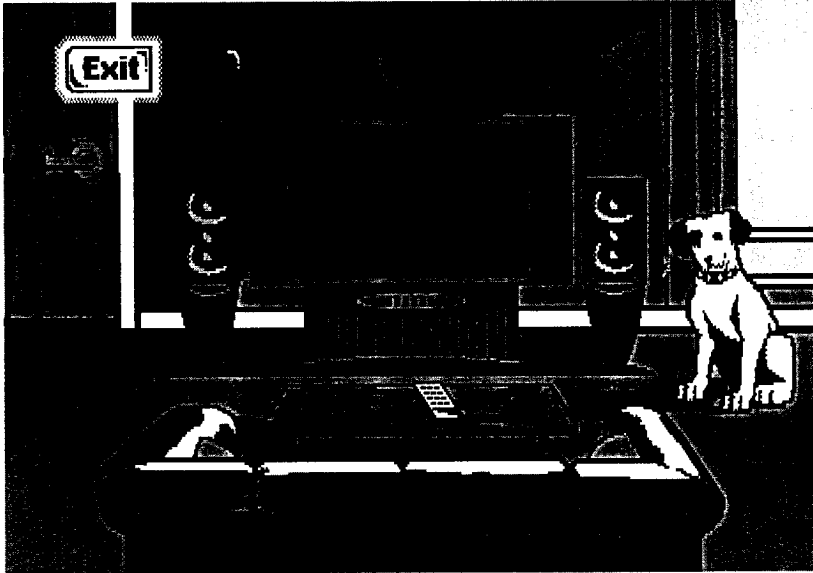

2. Press MENU. The Living Room disappears.

USING THE MENU SYSTEM

The Help Button

All menus have a *Help* button. For example, selecting the *Help* button from the Main Menu brings up all of the help balloons for the Living Room.

1. Press MENU to bring up the Living Room Main Menu.
2. Point to the *Help* button and press MENU. The help balloons appear.

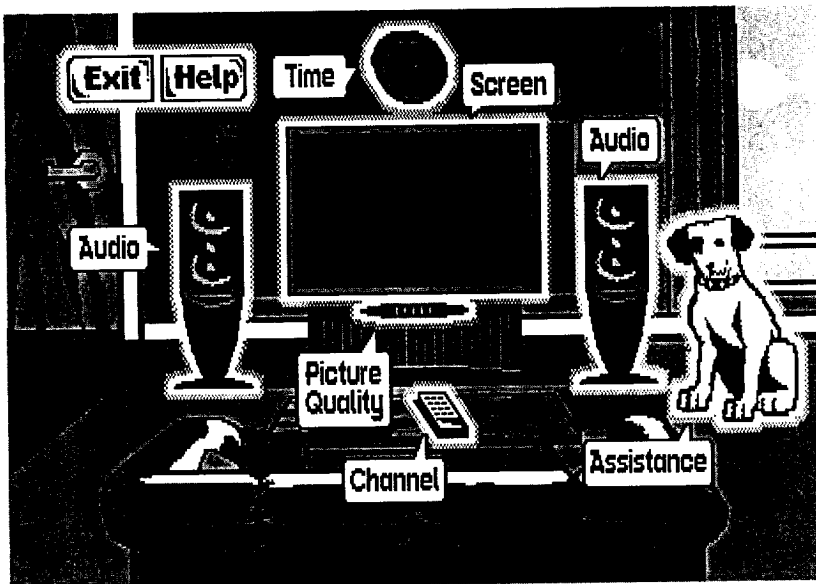

3. Press MENU again. The help balloons disappear.

The rest of the Help buttons in the menu system bring up helpful information explaining one aspect of that menu.

USING THE MENU SYSTEM

THE MENUS

There are six menus available from the Living Room Main Menu. When you point to different items in the Living Room, a different menu highlights. Press MENU on the remote to select the highlighted menu.

To exit a menu

There are two ways to exit a menu:

- Point to *Exit* and press MENU.
- Press CLEAR. The on-screen displays clear from the screen and you return to TV viewing.

CONTROLS

Controls do the work in the menu system. Using the controls, you can choose a setting, enter a number, or adjust a level such as tint or brightness. There are three kinds of controls: sliders, toggles, and path buttons.

Sliders

Use sliders to adjust a particular setting in a menu.

For example, to adjust the TV's tint:

1. Press MENU to bring up the Living Room Main Menu.
2. Point to the Picture Quality Menu and press MENU. (The Picture Quality menu is the TV's front panel, just below the TV screen.) The Picture Quality menu appears.
3. Point to *Tint*.
4. Point left or right to adjust the indicator line. Notice that the picture changes as you adjust the tint.
5. Press CLEAR to remove the display from the screen.

Now that you know how the Tint slider works, you know how all sliders work.

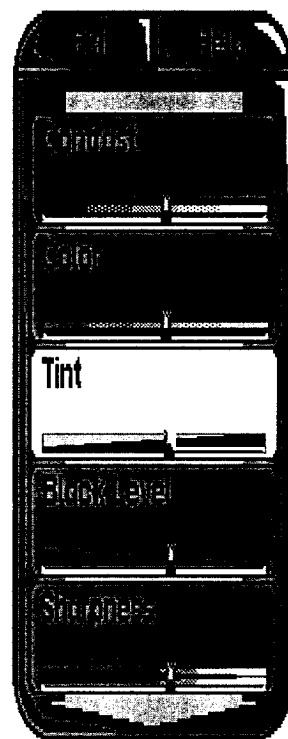

You don't need to remember the names of the types of controls. Once you've learned how each type works, you'll be able to use any part of the menu system.

USING THE MENU SYSTEM

Toggles

Use toggles to choose a particular setting from several available settings.

For example, to indicate which antenna you are using:

1. Press MENU to bring up the Living Room Main Menu.
2. Point to Channel (the remote control on the table) and press MENU. The Channel menu appears.
3. Point to *Signal Source*. The Signal Source toggle highlights. The current setting for Signal Source appears at the bottom of the toggle.
4. Point left or right to indicate the correct setting for your connection.
5. Press CLEAR to return to TV viewing.

Now that you know how the Signal Source toggle works, you know how all toggles work.

Path Buttons

A path button is a control that takes you to part of the menu system. You can recognize a path button by its distinctive arrow-shape. The Lists and Labels control in the Channel menu, above, is a path button.

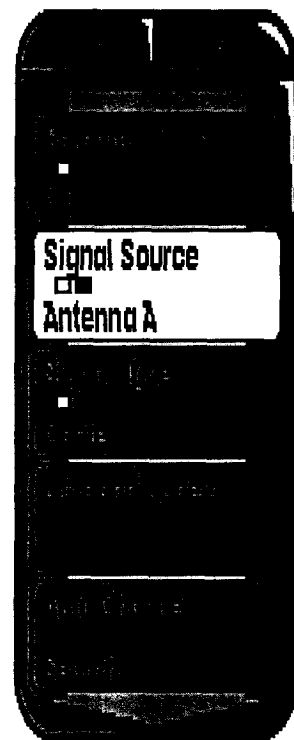

USING THE MENU SYSTEM

CONTROL PANELS

Control panels can contain different types of controls, such as numeric entry, sliders, and checkboxes, that let you adjust the TV. A slider in a control panel works just like a slider in a menu. Numeric entry and checkboxes are described below.

Numeric Entry

A control panel with a numeric entry control allows you to enter numbers and letters.

For example, to set the current time:

1. Press MENU to bring up the Living Room Main Menu.
2. Point to Time (the clock) and press MENU. The Time menu appears.
3. Point to *Set Time and Day*. The Set Time and Day numeric entry control panel appears to the right of the menu.
4. Press MENU. The plus sign and the hours and minutes field are highlighted.
5. Press MENU repeatedly, or press and hold MENU for 'fast mode', to set the time forward. To set the time back, point to the minus sign and press MENU.
6. Press the right arrow to move to the next column, then press MENU to switch between AM and PM.
7. Press the right arrow to move to the next column, then press MENU repeatedly to move the day forward. Point to the minus sign and press MENU to move the day backwards.
8. When you have entered the correct time, press the left arrow to return to *Set Time and Day*.
9. Press CLEAR to return to normal viewing.

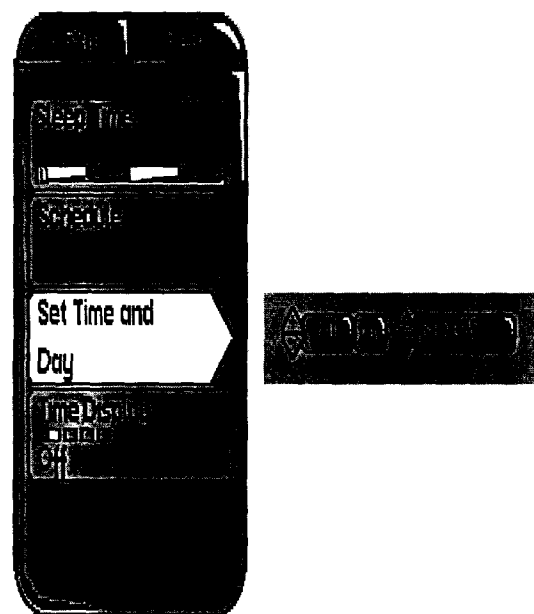

You can also use the number buttons for numeric fields such as channels and times.

USING THE MENU SYSTEM

Checkboxes

Use checkboxes to add a particular channel to a list of channels, or to remove the channel from a list.

For example, to add channel 13 to your list of favorite channels:

1. Press MENU to bring up the Living Room Main Menu.
2. Point to Channel (the remote control) and press MENU. The Channel menu appears.
3. Point to *Lists and Labels* and press MENU. The Lists and Labels control panel appears. The Normal channel list checkbox is highlighted.

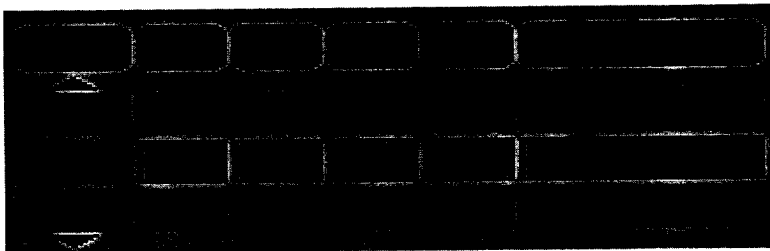

4. Point up repeatedly until channel 13 highlights.
5. Point right until the Fav checkbox highlights.
6. Press MENU to put channel 13 into the Favorite channel list. A check mark appears in the box. To remove channel 13 from the list, press MENU again.
7. Press CLEAR to return to normal viewing.

Now that you know how the Favorite Channel checkbox works, you know how all checkboxes work.

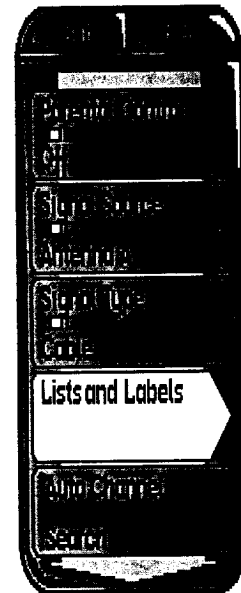

Once you've set up your FAV list, you can set the TV to show only your favorite channels. Select *Options* from the Screen menu, then choose the FAV Channel List.

USING THE MENU SYSTEM

EXPLORE, EXPLORE, EXPLORE!

Once you've learned the basics, feel free to poke around in the menu system. The context-sensitive help at the bottom of the screen provides instructions for getting through any particular menu or control panel. Remember, press CLEAR at any time to leave the menu system and return to regular TV viewing.

When you've had your fill, proceed to the next section of the manual, *Interactive Setup*.

INTERACTIVE SETUP

THERE'S AN ON-SCREEN SETUP ROUTINE

Your TV has an interactive setup routine that walks you through the steps needed to configure the TV. There are five sections:

- Connect the TV
- Search for available channels
- Set the time and day
- Set speaker configuration
- Make channel lists and labels

FIRST THINGS FIRST

USING THE MENU SYSTEM

3 INTERACTIVE SETUP



PROGRAMMING THE REMOTE

Complete the second step, *Search for Channels*, to receive antenna or cable TV signals. After that, you can skip other steps and return to them at your convenience.

INTERACTIVE SETUP

ENTERING THE INTERACTIVE SETUP

The interactive setup routine is accessed through the Assistance menu:

1. Press MENU to bring up the Living Room Main Menu.

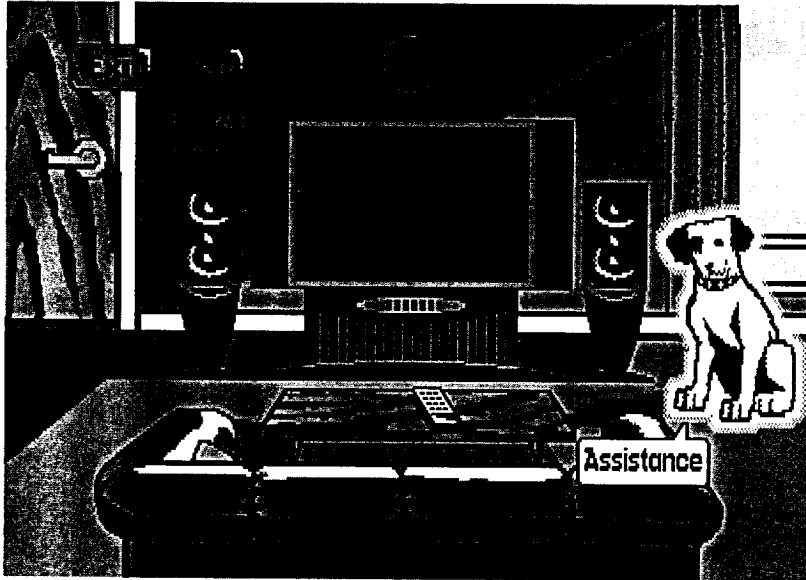

2. Point to Nipper to highlight the Assistance menu and press MENU. The Assistance menu appears with the Setup control highlighted.
3. Press MENU to select Setup. You are asked if you want to begin the setup routine. Press MENU to begin.

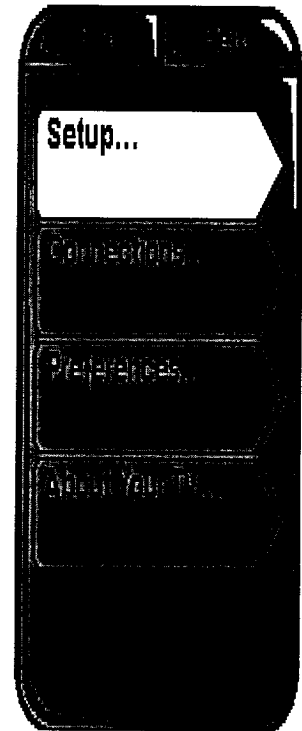

You must complete the Search for Channels to receive TV signals and put channels in memory.

You can also access Search for Channels through the Auto Channel Search control in the Channel menu.

INTERACTIVE SETUP

STEP 1: CONNECT THE TV

This section of the setup asks questions about the components you have and walks you through the steps needed to connect your TV to a VCR, Digital Satellite System receiver, and laserdisc player. If you used the Connections Foldout to connect your TV, you can skip this step or follow along for the sheer fun of it. If you haven't connected your TV to any other components, answer the questions and follow the on-screen instructions.

1. Follow the on-screen instructions to connect your TV and other components. When you complete these instructions, you are automatically taken to the next step in the interactive setup routine.

STEP 2: SEARCH FOR CHANNELS

The second step automatically searches for all channels available through your antenna or cable TV system. This is also called "Automatic Channel Search."

1. Follow the on-screen instructions to complete the automatic channel search.
2. When the channel search is completed, press MENU to go to the next step.

About the Remaining Steps

The remaining steps let you set the time and day, set up your speakers, place channels in various lists, and label each channel. Some of these steps, such as setting up your channel lists, can be time consuming. Feel free to skip any or all of these steps and return to them later.

STEP THREE: SET THE TIME

1. Follow the on-screen instructions to set the time and day of the week.
2. Point to *Exit* and press MENU to go to the next step.

A tip from Keith, the Designing Engineer:

When you use the Lists and Labels control panel, use the arrow buttons to point to any channel or field. Use the CHAN buttons to point up or down to any checkmarked channel in whichever field you have selected.

INTERACTIVE SETUP

STEP FOUR: SET THE SPEAKER CONFIGURATION

This step lets you tell the TV how many speakers you have connected to your TV.

1. Point left or right to indicate the speaker setup that matches your system.
2. Point to EXIT and press MENU to go to the next step.

STEP FIVE: EDIT CHANNEL LABELS

This step lets you set up your channel lists and assign or build labels for your channels.

1. Follow the on-screen instructions to set up your channels and channel lists.
2. Point to EXIT and press MENU to complete the interactive setup.

WHAT NOW?

Now that you've finished the interactive setup, you can sit back, relax, and enjoy the TV. Or...

Program the Remote

Since you've gone this far, in just a few minutes you can program the remote control to work with your VCR, laserdisc player, and other component. To find out how to program both of the remotes, go to the next section.

PROGRAMMING THE

REMOTES

IF YOU HAVE A VCR OR OTHER COMPONENT...

You can program the universal remote to control most brands of remote controllable TVs, VCRs, and cable boxes. If you have an RCA, GE or ProScan component, you may not need to program the remote at all. Other manufacturer's brands need to be programmed.

You can program the simple remote to control most remote controllable VCRs.

NOW WATCH SOME TV!

FIRST THINGS FIRST

USING THE MENU SYSTEM

INTERACTIVE SETUP

4 PROGRAMMING THE REMOTE

PROGRAMMING THE REMOTES

PROGRAMMING THE UNIVERSAL REMOTE

You can program the universal remote to control most brands of remote controllable TVs, VCRs, and cable boxes. If you have an RCA, GE or PROSCAN VCR, you may not need to program the remote at all. Other manufacturer's brands need to be programmed.

Programming the Universal Remote to Control a VCR

To determine whether you need to program the universal remote, turn on the VCR, point the remote at the VCR and press the VCR1 button. Then, press POWER or CHAN ^ or CHAN v to see if the VCR responds to the remote commands. If not, you need to program the remote.

Follow these steps to program your universal remote to control your VCR:

1. Turn on the VCR to be programmed.
2. Look up your VCR brand and code number(s) in the code list on the next page or on the code sheet packed with your remote.
3. Press and hold the VCR1 button on the remote.
4. Enter the two-digit code from the code list.
5. Release VCR1, then press POWER to see if the VCR responds to the remote commands. If it doesn't, try pressing VCR1 and POWER to see if the VCR responds.
6. Repeat steps 3 through 5 using the next code listed for your brand until the VCR responds to the remote commands.

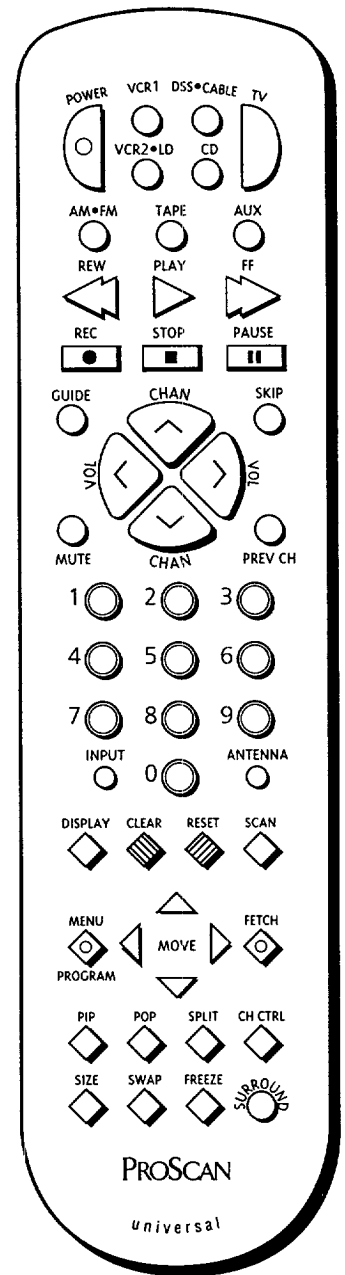

This remote may not operate all models of the brands shown on the next page.

To program the VCR2•LD button to control a second VCR, follow the steps on this page, but use the VCR2•LD button instead of the VCR1 button.

For instructions on programming the simple remote, see page 28.

PROGRAMMING THE REMOTES

Universal Remote VCR Codes

Admiral	006	JVC	002,014,016,030,046	Sansui	016,071
Aiwa	015	Kenwood ...	002,014,016,030,044,046	Sanyo	002,012
Akai	003,017,022,023,063,066	Lloyd's	015	Scott	004,013,041,049,068
Audio Dynamics	014,016	Logik	031	Sears	002,005,009,012,018, 019,035,043,048
Bell&Howell	002	Magnavox.....	008,029,053,056	Sharp	006,024,027,039,045
Broksonic	010	Marantz	002,008,014,016,029,030, 044,046,061	Shintom	017,026,031,055
Candle	007,009,013, 044,045,046,052	Marta	009	Signature	015
Cannon	008,053	MEI	008	Sony	017,026,038
Capehart.....	001	Memorex.....	008,009,012,015	Sylvania.....	008,015,029,053,056
Citizen	007,009,013, 044,045,046,052	MGA	004,027	Symphonic	015
Colortyme	014	Midland	032	Tandy	002,015
Craig	007,012	Minolta	005,035	Tashiko	009
Curtis Mathes.....	000,007,008,014, 015,044,046,053,064,067	Mitsubishi	004,005,027,035,040	Tatung	030
Daewoo	013,045,052	Montgomery Ward	006	Teac	05,030,069
dbx	014,016	MTC	007,015	Technics	008
Dimensia	000	Multitech	007,015,031,032	Teknika	008,009,015,021
Dynatech	015	NEC	002,014,016,030, 044,046,059,061,064	Toshiba	005,013,019,048,049
Electrohome	027	Panasonic.....	008,053	Totevision	007,009
Emerson	008,009,010,013,015, 020,023,027,034,041,042, 047,049,057,062,065,067,068,070	Pentax	005,035,044	TMK	067
Fisher ..	002,012,018,019,043,048,058	Pentex Research	046	Unitech	007
Funai	015	Philco	008,029,053,056	Vector Research	014,016,044
GE	000,007,008,032,037,053	Philips	008,029	Victor	016
Goldstar	009,014,046,060	Pioneer.....	005,016,050	Video Concepts	014,016,044
Harman Kardon	014	Portland	044,045,052	Videosonic	007
Hitachi	005,015,035,036	ProScan	000	Wards.....	005,006,007,008,009, 012,013,015,025,027,031,035
Instant Replay	008	Quartz.....	002	Yamaha	002,014,016,030,046
JCL	008	Quasar	008,053	Zenith	011,017,026,072
JC Penney	002,005,007,008,014, 016,030,035,051,053	RCA	000,005,007,008,028 ,035,037,054,069		
		Radio Shack/Realistic	002,006,008, 009,012,015,019,027,043,053		
		Samsung	007,013,022,032,042		

PROGRAMMING THE REMOTES

Programming the Universal Remote to Control the RCA DSS™ Receiver

The universal remote is preprogrammed to control the RCA DSS™ receiver. Many buttons on your TV remote have the same functions as the buttons on the RCA DSS™ remote. You may want to experiment with other buttons on the remote to see if they work with your receiver.

Programming the Universal Remote to Control a Satellite Receiver

Refer to the Connection Foldout or contact your satellite company to hook up your satellite receiver. If you have a satellite box with its own remote, you also may be able to use the TV's remote with your satellite receiver. Use the codes in the code list on the right or on the sheet packed with your remote. However, this remote may not operate all models of the brands that are shown in the code list.

1. Turn on the satellite receiver.
2. Look up your brand and its code number(s) on the code list at the right.
3. Press and hold the DSS•CABLE button on the remote.
4. Enter the two-digit code from the code list.
5. Release DSS•CABLE, then press POWER or CHAN ^ or CHAN v to see if the satellite receiver responds to the remote commands.
6. Repeat steps 3 through 5 using the next code listed for your brand until the satellite receiver responds to the remote commands.

Satellite Receiver Codes

Chaparral	080,081
Cheyenne	081
Drake	082,083
General Instruments	092,093,094
Realistic	084
Sierra I,II,III	081
STS1	085
STS2	086
STS3	087
STS4	088
Toshiba	089
Uniden	090
Video Cipher II	091

PROGRAMMING THE REMOTES

Programming the Universal Remote to Control a Cable Box

Refer to the Connection Foldout or contact your cable company to hook up your cable box. If you have a cable box with its own remote, you also may be able to use the TV's remote with your cable box. This remote can be programmed to control either a DSS receiver or a cable box, not both. Use the codes in the code list on the right or on the sheet packed with your remote. This remote may not operate all models of the brands that are shown in the code list.

1. Turn on the cable box.
2. Look up your brand and its code number(s) on the code list at right.
3. Press and hold the DSS•CABLE button on the remote.
4. Enter the two-digit code from the code list.
5. Release DSS•CABLE, then press POWER or CHAN ^ or CHAN v to see if the cable box responds to the remote commands.
6. Repeat steps 3 through 5 using the next code listed for your brand until the cable box responds to the remote commands.

Cable Box Codes

ABC	022,046,053,054
Anvision	007,008
Cablestar	007,008
Diamond	056
Eagle	007,008
Eastern Int.	002
General Instuments	046
GI 400	004,005,015,023,024,025,030,036
Hamlin	003,012,013,034,048
Hitachi	037,043,046
Jerrold	004,005,015,023,024,025,030,036, 045,046,047,062,065
Macom	037,043
Magnavox	007,008,019,021,026, 028,029,032,033,040,041
NSC	009
Oak	001,016,038
Oak Sigma	016
Panasonic	003,027,039,061
Philips	007,008,019,021,026, 028,029,032,033,040,041
Pioneer	018,020,044
RCA	000,027
Randtek	007,008
Regal	003,012,013
Regency	002,033
Samsung	044
Sci. Atlanta	003,022,035,063,064
Signature	046
Sprucer	027
Starcom	046
Stargate 2000	058
Sylvania	011,059
Teknika	006
Texscan	010,011,059
Tocom	017,021,049,050,055
Unika	031,032,041
Universal	051,052,060
Viewstar	007,008,019,021,026, 028,029,032,033,040,041
Warner Amex	044
Zenith	014,042,057,061

PROGRAMMING THE REMOTES

Programming the Universal Remote to Control a Laserdisc Player

Use the codes in the code list on the right or on the sheet packed with your remote. However, this remote may not operate all models of the brands that are shown in the code list on the right.

Follow these steps to program your universal remote to control your laserdisc player:

1. Turn on the laserdisc player.
2. Look up your brand and code number(s) in the code list.
3. Press and hold the VCR2•LD button on the remote.
4. Enter the two-digit code from the code list.
5. Release VCR2•LD, then press POWER to see if the laserdisc player responds to the remote commands. If it doesn't, try pressing VCR2•LD, then POWER again.
6. Repeat steps 3 through 5 using the next code listed for your brand until the laserdisc player responds to the remote commands.

Programming the Universal Remote to Control an Audio Component

To program the remote for a remote-controllable audio component, point the remote at the component and press the correct component button: AUX for an AV receiver, CD for a CD player, etc. Then, press POWER or CHAN up or down. If the component doesn't respond, the remote needs to be programmed. Use the codes in the code list on the next page or on the sheet packed with your remote. However, this remote may not operate all models of the brands that are shown in the code list.

Follow these steps to program your universal remote to control your audio component:

1. Turn on the component to be programmed.
2. Look up your brand and code number(s) on the code list.
3. Press and hold the component button on the remote.
4. Enter the two-digit code from the code list.
5. Release component button, then press POWER to see if the component responds to the remote commands. If it doesn't, try pressing the component button, then POWER again.
6. Repeat steps 3 through 5 using the next code listed for your brand until the component responds to the remote commands.

Laserdisc Player Codes

ProScan	033
RCA	033
Pioneer	033

PROGRAMMING THE REMOTES

Audio Component Codes

ADS		ONKYO	
AMP.....	001	AM/FM.....	082
AIWA		CD.....	078
CD.....	060	TAPE.....	080,081
AKAI		PHONO.....	079
AMP.....	002,008	PANASONIC	
DENON		AMP.....	012
CD.....	057	AM/FM.....	038
DYNAMIC BASS		CD.....	036,083
AM/FM.....	029	TAPE.....	037
CD.....	025	PHILLIPS	
TAPE.....	026,027	AMP.....	062
PHONO.....	028	AM/FM.....	062
EMERSON		CD.....	061
CD.....	066	PIONEER	
FISHER		AMP.....	014
AMP.....	023	AM/FM.....	042
CD.....	067	CD.....	039
HITACHI		TAPE.....	040,041
CD.....	063	RCA	
JVC		AMP.....	024
AMP.....	016,058	AM/FM.....	003
AM/FM.....	030,035	CD.....	007,043,044
CD.....	032	TAPE.....	006
TAPE.....	033,034	PHONO.....	005
AUX.....	031	AUX.....	004,054
KENWOOD		REALISTIC	
AMP.....	017,074	CD.....	063,066
AM/FM.....	074	SANSUI	
CD.....	067,070,077	CD.....	045
TAPE.....	071,072	SCOTT	
PHONO.....	073	CD.....	066
KYOCERA		TAPE.....	055,056
AMP.....	009	SHERWOOD	
LOTTE (NEC)		AMP.....	011,013
CD.....	075	SONY	
MAGNAVOX		AMP.....	021
AMP.....	065	AM/FM.....	049
AM/FM.....	065	CD.....	046
CD.....	061	TAPE.....	048,053
MARANTZ		PHONO.....	047
AMP.....	022,076	TEAC	
AM/FM.....	076	AMP.....	010
CD.....	068	CD.....	069
MITSUBISHI		TECHNICS	
AMP.....	015,059	AM/FM.....	052
AM/FM.....	059	CD.....	050
NAKAMICHI		TAPE.....	051
AMP.....	020	YAMAHA	
		AMP.....	018,019

PROGRAMMING THE REMOTES

PROGRAMMING THE SIMPLE REMOTE

There are two methods to program the simple remote's VCR button: CODE SEARCH and DIRECT ENTRY. The simple remote's TV button is already programmed for your TV.

To program the VCR button using CODE SEARCH

1. Make sure the VCR is turned off *unless it is a GE, PROSCAN, or RCA product*. If the VCR is a GE, PROSCAN or RCA product, turn it on.
2. Press the VCR button and the POWER button simultaneously.
3. Release the two buttons.
4. Press the POWER button repeatedly until the VCR turns ON.
5. Press the CHAN v button to verify the VCR operates correctly. Press MENU to complete the process.

To program the VCR button using DIRECT ENTRY

1. Find the keypress combination for your VCR by locating your brand of VCR in the VCR Codes table on the next page.
2. Note the code numbers that follow your brand of VCR.
3. Locate the code number in the Key Combination chart on the next page.
4. Press and hold the VCR button.
5. Enter the four keypresses shown in the Key Combination Chart.

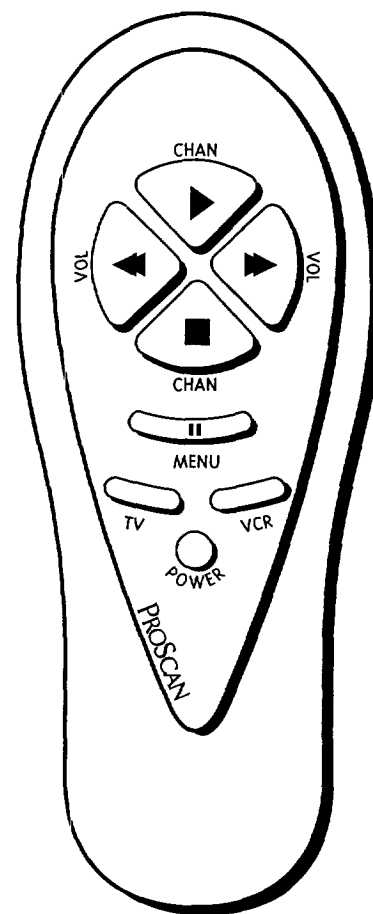

Symbol	Simple Remote Button
^	CHAN UP
v	CHAN DOWN
>	VOL UP
<	VOL DOWN

PROGRAMMING THE REMOTES

Simple Remote VCR Codes

Admiral	06	Montgomery Ward	06
Aiwa	15	MTC	07,15
Akai	03,17,22,23,63,66	Multitech	07,15,31,32
Audio Dynamics	14,16	NEC	02,14,16,30,44,46,59,61,64
Bell&Howell	02	Panasonic	08,53
Broksonic	0	Pentax	05,35,44
Candle	07,09,13,44,45,46,52	Pentex Research +	46
Cannon	08,53	Philco	08,29,53,56
Capehart	01	Philips	08,29
Citizen	07,09,13,44,45,46,52	Pioneer	05,16,33 (laser disc),50
Colortyme	14	Portland	44,45,52
Craig	07,12	ProScan	00
Curtis Mathes	00,07,08, 14,15,44,46,53,64,67	Quartz	02
Daewoo	13,45,52	Quasar	08,53
dbx	14,16	RCA	00,05,07,08,28,35,37,54,69
Dimensia	00	Radio Shack/Realistic	02,06,08, 09,12,15,19,27,43,53
Dynatech	15	Samsung	07,13,22,32,42
Electrohome	27	Sansui	16,71
Emerson	08,09,10,13,15, 20,23,27,34,41,42,47, 49,57,62,65,67,68,70	Sanyo	02,12
Fisher	02,12,18, 19,43,48,58	Scott	04,13,41,49,68
Funai	15	Sears	02,05,09,12,18, 19,35,43,48
GE	00,07,08,32,37,53	Sharp	06,24,27,39,45
Goldstar	09,14,46,60	Shintom	17,26,31,55
Harman Kardon	14	Signature	15
Hitachi	05,15,35,36	Sony	17,26,38
Instant Replay	08	Sylvania	08,15,29,53,56
JCL	08	Symphonic	15
JC Penney	02,05,07,08, 14,16,30,35,51,53	Tandy	02,15
JVC	02,14,16,30,46	Tashiko	09
Kenwood	02,14,16,30,44,46	Tatung	30
Lloyd's	15	Teac	15,30,69
Logik	31	Technics	08
Magnavox	08,29,53,56	Teknika	08,09,15,21
Marantz	02,08,14,16,29, 30,44,46,61	Toshiba	05,13,19,48,49
Marta	09	Totevision	07,09
MEI	08	TMK	67
Memorex	08,09,12,15	Unitech	07
MGA	04,27	Vector Research	14,16,44
Midland	32	Victor	16
Minolta	05,35	Video Concepts	14,16,44
Mitsubishi	04,05,27,35,40	Videosonic	07
		Wards	05,06,07,08,09, 12,13,15,25,27,31,35
		Yamaha	02,14,16,30,46

Key Combinations

00 ^ ^ ^ ^	51 ^ < ^ <
01 ^ ^ ^ >	52 ^ < > ^
02 ^ ^ ^ v	53 ^ < > >
03 ^ ^ ^ <	54 ^ < > v
04 ^ ^ > ^	55 ^ < > <
05 ^ ^ > >	56 ^ < v ^
06 ^ ^ > v	57 ^ < v >
07 ^ ^ > <	58 ^ < v v
08 ^ ^ v ^	59 ^ < v <
09 ^ ^ v >	60 ^ < < ^
10 ^ ^ v v	61 ^ < < >
11 ^ ^ v <	62 ^ < < v
12 ^ ^ < ^	63 ^ < < <
13 ^ ^ < >	64 > ^ ^ ^
14 ^ ^ < v	65 > ^ ^ >
15 ^ ^ < <	66 > ^ ^ v
16 ^ > ^ ^	67 > ^ ^ <
17 ^ > ^ >	68 > ^ > ^
18 ^ > ^ v	69 > ^ > >
19 ^ > ^ <	70 > ^ > v
20 ^ > > ^	71 > ^ > <
21 ^ > > >	72 > ^ v ^
22 ^ > > v	73 > ^ v >
23 ^ > > <	74 > ^ v v
24 ^ > v ^	75 > ^ v <
25 ^ > v >	76 > ^ < ^
26 ^ > v v	77 > ^ < >
27 ^ > v <	78 > ^ < v
28 ^ > < ^	79 > ^ < <
29 ^ > < >	80 > > ^ ^
30 ^ > < v	81 > > ^ >
31 ^ > < <	82 > > ^ v
32 ^ v ^ ^	83 > > ^ <
33 ^ v ^ >	84 > > > ^
34 ^ v ^ v	85 > > > >
35 ^ v ^ <	86 > > > v
36 ^ v > ^	87 > > > <
37 ^ v > >	88 > > v ^
38 ^ v > v	89 > > v >
39 ^ v > <	90 > > v v
40 ^ v v ^	91 > > v <
41 ^ v v >	92 > > < ^
42 ^ v v v	93 > > < >
43 ^ v v <	94 > > < v
44 ^ v < ^	95 > > < <
45 ^ v < >	96 > v ^ ^
46 ^ v < v	97 > v ^ >
47 ^ v < <	98 > v ^ v
48 ^ < ^ ^	99 > v ^ <
49 ^ < ^ >	100 > v > ^
50 ^ < ^ v	

PROGRAMMING THE REMOTES

Using the Remote to Control a Component

Once the remote has been programmed with the correct codes, you're ready to use it to control your component.

To operate the component using the remote:

1. Press the component button (TV, VCR, VCR2•LD, DSS•CABLE, AUDIO, etc.) to set the remote to control that component.
2. Press POWER to turn the device off or on.
3. Use the remote buttons that apply to that device (CHAN buttons, transport keys, etc.).

Tip for the Simple Remote

To change channels on the VCR, press and hold VCR, then press TV. Release both and use the CHAN buttons to change channels. To return to using the simple remote buttons as transport keys, press VCR.

For PROSCAN, RCA, and GE devices, pressing the device button will usually turn the device on. Use the POWER button to turn the device off.

TOUR OF THE TV

A PICTURE BOOK TOUR

This section gives a pictorial overview of the television. The parts detailed are:

- The Remote Control
- The Simple Remote
- The Channel Marker
- The Back Panel
- The Front Panel

TOUR OF THE TV

REMOTE CONTROL BUTTONS

POWER When in TV mode, turns off the TV. In VCR mode, and if programmed, turns on and off some VCRs.

VCR1 If programmed, turns on VCR and puts the remote in VCR mode. Also, turns on the TV.

DSS•CABLE Turns on the DSS receiver or, if programmed, some cable boxes. Puts the remote in DSS or CABLE mode. Also, turns on the TV.

VCR2•LD If programmed, turns on the second VCR or laserdisc player. Puts the remote in VCR2•LD mode. Also, turns on the TV.

TV Turns on the TV and puts the remote in TV mode. Also, displays channel information.

CD If programmed, turns on the compact disc player and puts the remote in CD mode.

AM•FM If programmed, turns on the AM/FM receiver and puts the remote in AM•FM mode.

TAPE If programmed, turns on the tape player and puts the remote in Tape mode.

AUX If programmed, turns on the auxiliary audio component and puts the remote in that mode.

REW, PLAY, FF, REC, STOP, PAUSE If programmed, provide transport control for some remote-controllable VCRs, laserdisc players, tape decks, and CD players.

VOL < or VOL > Decreases or increases the TV's volume.

CHAN ^ or CHAN v Scans up or down through the current channel list. Press once to change the channel up or down. Press and hold to continue changing channels.

DISPLAY Brings up channel information. Press repeatedly to see detailed program information, if available.

SKIP Press once before changing channels, and the TV waits 30 seconds before returning you to the original channel. Press repeatedly to add more time.

MUTE Turns off the TV's sound. Press again to restore the sound.

PREV CH Returns to the previous channel.

(0-9) Number Buttons Enters channel numbers and time settings directly from the remote control. To enter a two-digit channel, press the two digits. To enter a three-digit channel, press and hold the 1 digit, then add the second two. For example, to tune to channel 123, press and hold 1. Then, press 2 and press 3.

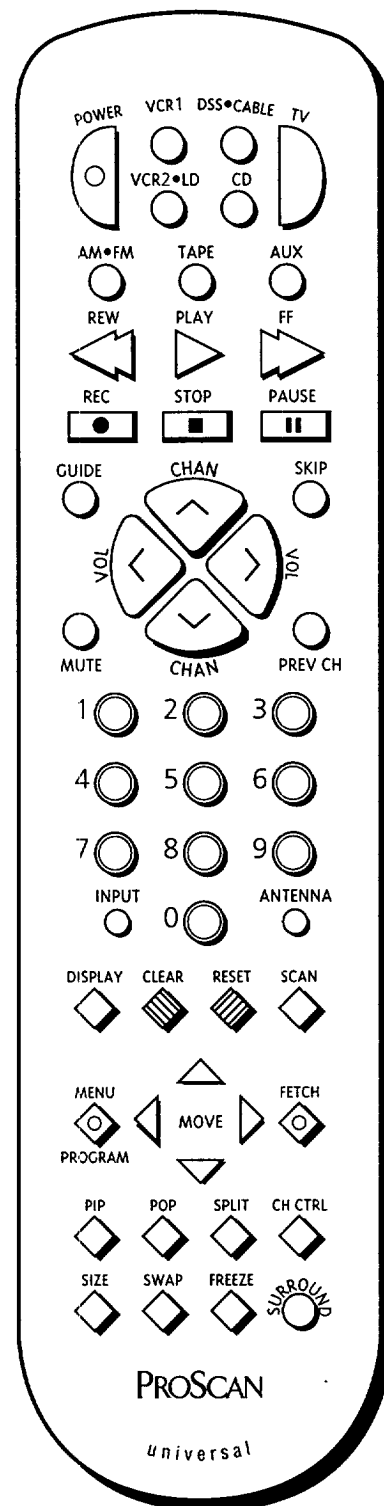

For more, see *Programming the Universal Remote*, p. 22.

TOUR OF THE TV

INPUT Press to toggle through the available input sources (VID1, VID2, VID3, FRNT, etc.).

ANTENNA When in TV mode, changes the antenna input. Functions as TV•VCR button in VCR mode and TV•DSS button in DSS•CABLE Mode.

CLEAR Removes any menu or display from the screen and returns to TV viewing.

MENU Brings up the Main Menu. When in the menu system, selects highlighted items. When on an Exit button, returns to the previous menu. When in VCR mode, functions as a Program button.

RESET Returns all picture quality controls to their original settings.

MOVE (Arrows) Used to point to different items in the menu system. Also used to adjust the menu controls and to move the PIP window when no menus are on the screen.

PIP Brings up the small picture-in-picture window. Press again to remove the PIP window.

SPLIT Divides the main picture into left and a right pictures. Press again to remove the split screen.

POP Brings up three small picture-outside-picture windows. Press again to remove the POP windows.

GUIDE Brings up twelve small pictures that are previews of the next twelve channels in the channel list. Use the up and down arrows to see the previous or next four channels. Press MENU to go to the channel you have highlighted. Press GUIDE again to remove the channel guide.

CH CTRL Selects whether the main picture or a PIX+ window is affected by the CHAN and FREEZE buttons.

SWAP Swaps the main picture with the currently selected PIX+ window.

FREEZE Freezes the video in the main picture or PIP window, if it's displayed.

SIZE Selects the size of the PIP window.

SCAN Briefly displays each channel from the current channel list. Press again to stop scan.

SURROUND Press once to display the current audio processor. Press repeatedly to toggle through the available audio processors.

FETCH Contains up to five frequently used controls from other menus. You can choose what controls are available at the fetch menu.

The POP windows display antenna or cable TV signals. Signals from the Video INPUTS are not displayed in POP mode.

To add your own favorite control to the Fetch Menu, see *Using and Modifying Fetch*, p. 59.

TOUR OF THE TV

SIMPLE REMOTE BUTTONS

VOL < Decreases the volume. When in the menu system, VOL < is used to point to items and adjust menu controls. In VCR mode, it functions as a REW or reverse search button.

VOL > Increases the volume. When in the menu system, VOL > is used to point to items and adjust menu controls. In VCR mode, it functions as a FF or fast search button.

CHAN ^ Scans up through the channel list. In the menu system, it points to items and adjusts menu controls. In VCR mode, it functions as a PLAY button.

CHAN v Scans down through the current channel list. In the menu system, it points to items and adjusts menu controls. In VCR mode, it functions as a STOP button.

MENU Brings up the Main Menu. When in the menu system, it selects highlighted items. Also returns to the previous menu. When in VCR mode, it functions as a PAUSE button.

TV Turns on the TV and puts the remote in TV mode. Also displays channel information.

VCR If programmed, turns on the VCR and puts remote in VCR mode. Also turns on the TV.

POWER Turns off the TV. Also turns some VCRs off and on.

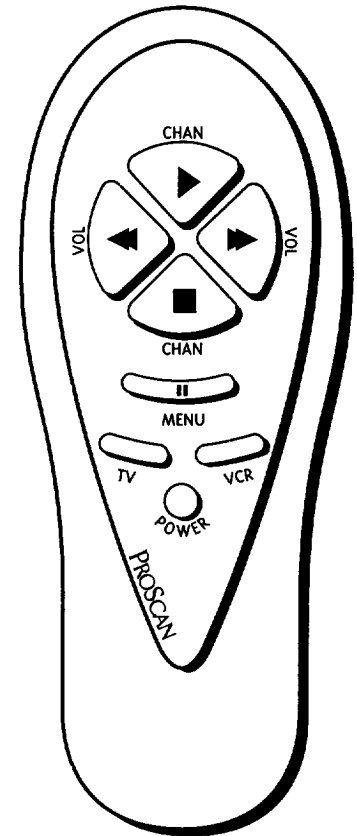

For more, see *Programming the Simple Remote*, p. 28.

To change channels on the VCR, press and hold **VCR**, then press **TV**. Release both buttons and use the **CHAN** buttons to change channels.

To return to using the remote buttons as transport keys, press **VCR**.

TOUR OF THE TV

CHANNEL MARKER

There are several indicators that come up when you change channels, press the DISPLAY button, or press the TV button. This display is called the Channel Marker.

9 Displays the current channel.

PIP 2 Displays the current PIP channel, if in use.

CNN If assigned using the Lists and Labels control panel, displays the channel logo for the current channel.

ANT A Displays the current input source.

CC Displayed when Closed Captioning is available on the current channel.

Stereo Displayed when the current channel is broadcasting in Stereo.

SAP Displayed when the current channel is broadcasting SAP (Second Audio Program) information.

Sleep Displayed when the Sleep Timer has been set.

NORM Displays the current channel list.

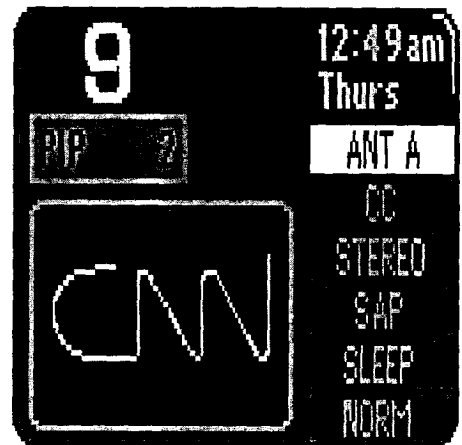

The channel marker shown above is just an example, of course.

TOUR OF THE TV

BACK PANEL

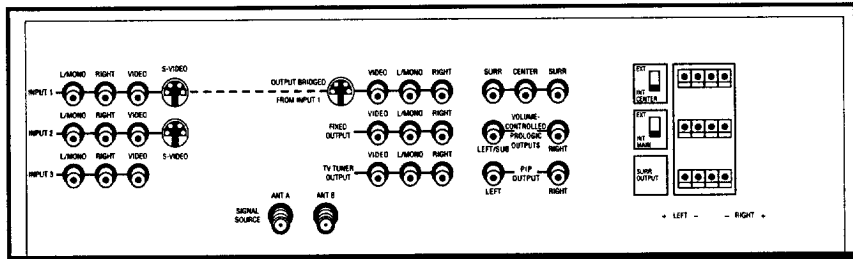

INPUT 1

Lets you connect a video component such as a VCR, DSS receiver, or laserdisc player.

L/MONO Provides left audio connection. Or, if you are connecting a mono component, use the L/MONO input. The left audio connector is usually white.

RIGHT Provides right audio connection. The right audio connector is usually red.

VIDEO Provides video connection. The video connector is usually yellow.

S-VIDEO Lets you connect a component with S-Video capability, such as a DSS receiver or S-Video VCR. When using S-Video, make sure to connect the three audio/video cables, as well as the S-Video connector.

INPUT 2

Provides connection to a second video component such as a VCR, DSS receiver, or laserdisc player. Its jacks are the same as described for INPUT 1, above.

INPUT 3

Provides connection to a third video component such as a VCR or laserdisc player.

L/MONO Provides left audio connection. Or, if you are connecting a mono component, use the L/MONO input. The left audio connector is usually white.

RIGHT Provides right audio connection. The right audio connector is usually red.

VIDEO Provides video connection. The video connector is usually yellow.

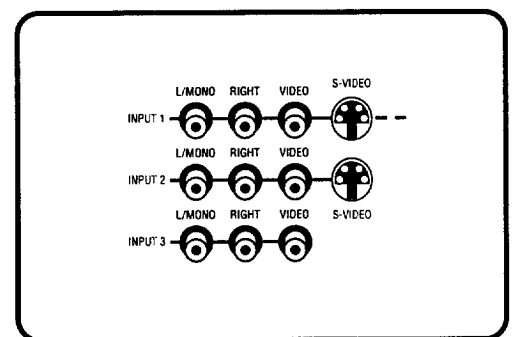

You can use the ANT B input for video games and switch between the two inputs using the ANTENNA button on the remote.

When using TV games, computers and similar products with your TV, keep the contrast at a low setting. If a fixed (non-moving) pattern is left on the screen for long periods of time at a high contrast setting, the image can be permanently imprinted onto the picture tubes. These types of imprints are not covered by your warranty because they are the result of misuse.

TOUR OF THE TV

SIGNAL SOURCE Provides connection to a home antenna or cable TV system.

OUTPUT BRIDGED FROM INPUT 1 Provides fixed-level audio and video from the INPUT 1 source only.

FIXED OUTPUT Provides fixed-level audio and video output from the TV. These output signals are ideal for connecting to an A/V receiver or amplifier that has its own remote control.

TV TUNER OUTPUT Provides audio and video output from the TV tuner. The TV TUNER OUTPUT jacks are ideal for connecting the TV to an AV receiver with video display, then routing the audio and video jacks back into the TV's audio/video inputs.

VOLUME-CONTROLLED PROLOGIC OUTPUTS These five jacks provide connections to an AV receiver or power amplifier.

PIP OUTPUT Provides audio output from the PIX+ window.

CENTER (switch) Lets you choose between playing center channel audio through the TV's internal speaker, or through an external center channel speaker connected to the TV.

CENTER CHANNEL SPEAKERS Lets you connect external center channel speakers to the TV.

MAIN (switch) The internal main speaker switch lets you turn off the TV's internal main speakers and play the main audio through external speakers connected to the TV.

MAIN SPEAKERS Lets you connect external left and right speakers to the TV.

SURROUND OUTPUT (SURR OUTPUT) SPEAKERS Lets you connect left and right surround channel speakers to the TV.

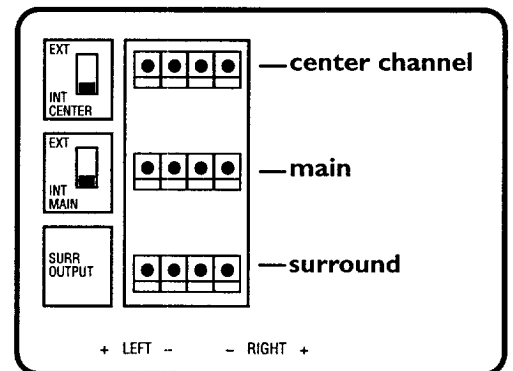
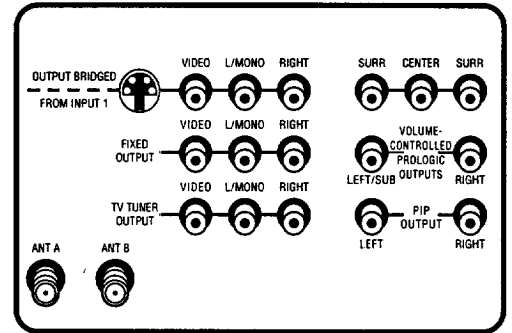

TOUR OF THE TV

FRONT PANEL

VOL < Decreases the volume. When in the menu system, use VOL < to point left to items and adjust menu controls.

VOL > Increases the volume. When in the menu system, use VOL > to point right to items and adjust menu controls.

CHAN ^ Scans up through the channel list. In the menu system, use it to point up to items and adjust menu controls.

CHAN v Scans down through the current channel list. In the menu system, use it to point down to items and adjusts menu controls.

MENU Brings up the Main Menu. In the menu system, use it to select highlighted items and return to the previous menu.

POWER Turns the TV on and off.

(Headphone) Plug stereo headphones into this jack.

A•V (Audio/Video Jack) Use the AV adapter, included with your TV accessories, to connect a camcorder or other device to the front of the TV.

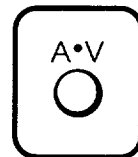
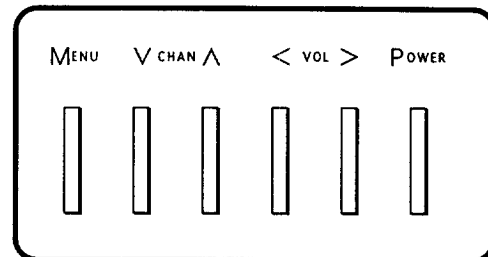

The front panel above shows a typical button layout. The exact look of the buttons may be different from those on the front of your TV.

If you turn Parental Control on, the front panel no longer provides access to the menus. For more information, see *Parental Control*, page 46.

QUICK REFERENCE

A SHORT GUIDE TO THE MENU SYSTEM

This section provides a brief explanation of all the menu commands on a menu-by-menu basis.

- **Audio** Contains the controls that let you adjust the way the TV sounds.
- **Picture Quality** Contains the controls that let you adjust the picture.
- **Screen** Contains the controls that let you adjust displays on the screen.
- **Time** Contains the controls that let you set the time and schedule the TV to turn off and on at specific times.
- **Channel** Contains the commands used to control your channels, including custom-building your channel list, setting parental controls, and setting up your TV to control the components connected to the TV.
- **Assistance** Contains the on-line guides that will help you set up your TV and add other components to your system.

QUICK REFERENCE

AUDIO MENU

Mute Lets you turn the TV's sound off or on.

Equalizer Takes you to slider bars that adjust the tone of each of the TV's external and internal speakers.

Speakers Lets you turn on or off the TV's internal, external or rear speakers.

Audio Processor

Lets you choose among the available audio modes, which control the way sound comes through your speakers.

Mono Plays the sound in mono only. This is a good choice when receiving broadcasts where distance makes the stereo signal weak.

Stereo Splits the incoming stereo audio signal into left and right channels. Most TV programs and recorded materials have stereo audio. The TV displays the word STEREO when you tune to a program that is broadcast in stereo.

Dolby 3 Splits the incoming audio signal into left, right and center channels.

Pro Logic Splits the incoming audio signal into left, right, center, and rear channels. You must connect rear speakers to hear the rear (surround) channel information.

Matrix Surround Splits the incoming audio signal into left, right, and rear channels. You must connect rear speakers to hear the rear (surround) channel information. This is a good choice when you're listening to monophonic audio, such as speeches, sporting events or plain dialog.

Hall Surround Splits the incoming audio signal into left, right, and rear channels. You must connect rear speakers to hear the rear (surround) channel information. This is a good choice for movies, music, etc.

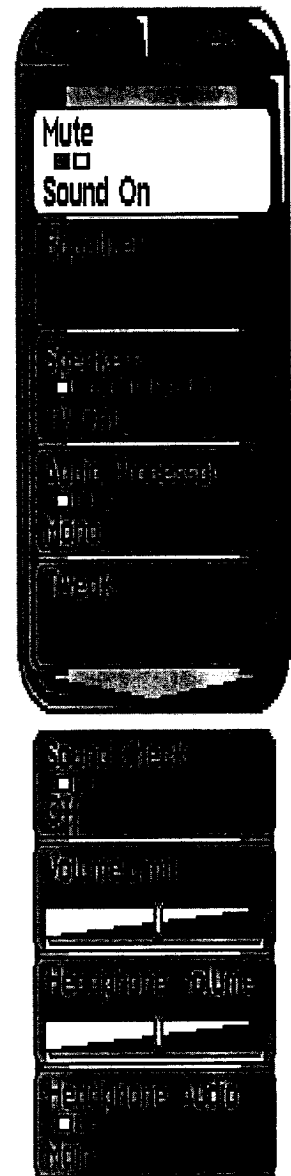

For more on the menus, see *Using the Menu System*, page 7.

QUICK REFERENCE

Tweak Takes you to a control panel that lets you make appropriate fine adjustments to your TV's sound. The changes you can make depend on the speaker configuration and the audio processor you chose.

Sound Check Lets you feed white noise through each of your speakers in turn, two seconds at a time to better adjust the balance among your speakers.

Volume Limit Lets you adjust the TV's maximum volume limit.

Headphone Volume Lets you set the volume of the sound played through headphones connected to the jack on the front of the TV.

Headphone Audio Lets you set whether the headphones play the audio from the main TV picture or the PIX+ window.

QUICK REFERENCE

PICTURE QUALITY MENU

Contrast Adjusts the difference between the light and dark areas of the picture.

Color Adjusts the richness of the color.

Tint Adjusts the balance between the red and green levels.

Black Level Adjusts the brightness of the picture.

Sharpness Adjusts the crispness of edges in the picture.

Auto Color Lets you turn on the feature that automatically corrects the color of the picture. This is especially useful for tracking realistic flesh tone colors as you switch from channel to channel. Select Off if you prefer to adjust the picture with the Picture Controls.

Video Noise Filter Lets you reduce noise, or 'snow,' in the picture.

Color Warmth Lets you set one of three automatic color adjustments: Cool (for a more blue palette of picture colors), Normal (for standard picture colors), and Warm (for a more red palette of picture colors).

Theatre Automatically sets the picture quality controls for optimal viewing in a darkened, theatre-like setting, for example, a darkened room.

Reset Picture Controls Lets you reset the picture controls to their original settings.

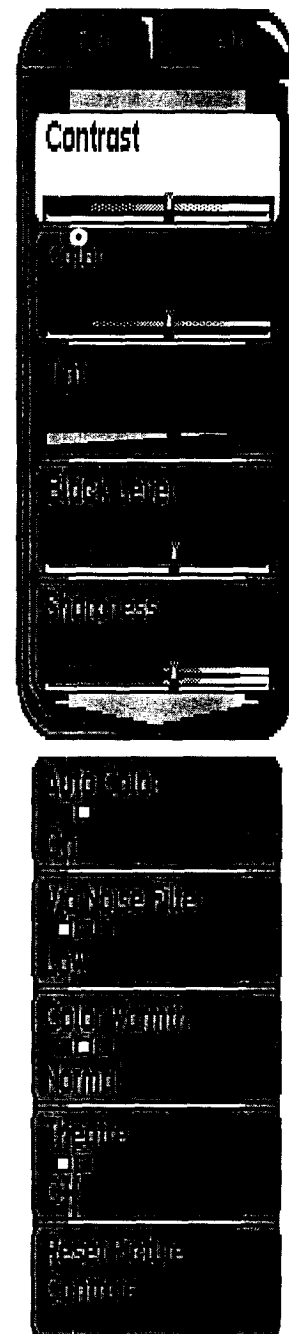

Turn the **Auto Color** feature **OFF** if you prefer to manually adjust the picture with the picture controls.

QUICK REFERENCE

SCREEN MENU

PIX+

Lets you set the PIX+ mode.

Single Screen The usual appearance of the TV.

PIP (Picture-in-Picture) A second, smaller picture appears in the corner of the screen.

Split Screen The screen is divided into two pictures, one on the left and one on the right.

POP (Picture-outside-Picture) Three secondary pictures appear on the right side of the screen.

Channel Guide Twelve small pictures appear on the screen.

Options

Lets you control the appearance of the current PIX+ mode.

Single Picture & Channel Guide Lets you choose whether the CHAN buttons provide access to your Normal or Favorite channel list.

PIP (Picture-in-Picture) Lets you control whether the main picture or the PIP window is affected by the CHAN button and at what size the PIP window is displayed.

Split Screen Lets you control which picture is affected by the CHAN button, and whether the Normal or Favorite channel list is available. An action button lets you swap the left and right pictures.

POP (Picture-outside-Picture) Lets you control which picture is affected by the CHAN button.

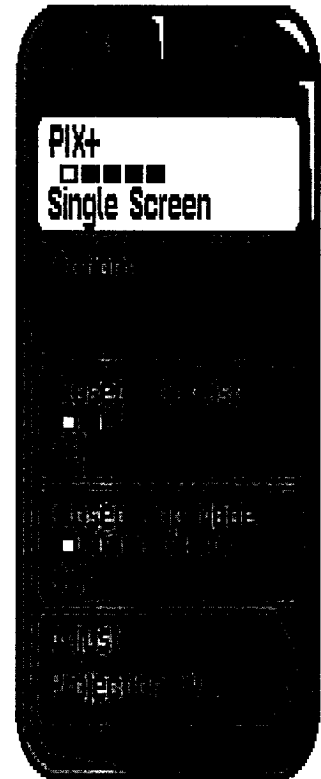

QUICK REFERENCE

Closed Captioning Display

Lets you choose the way closed captioning information is shown on the screen.

Off No captioning information displayed.

On Always Captioning information is displayed, when available.

On When Sound is Muted Captioning information is displayed, if available, when the TV's sound is muted. The captioning information is not displayed when the sound is on.

Closed Caption Mode Lets you choose a captioning mode for displaying captioning information.

Adjust Projection TV

Lets you adjust the TV's three color projection tubes for precise picture alignment.

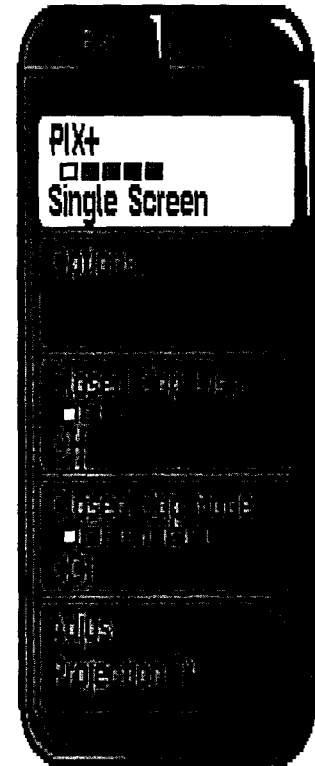

Captioning information is not available on all channels at all times. For more on using closed captioning, see *Advanced Features*, page 51.

QUICK REFERENCE

TIME MENU

Sleep Timer Lets you select how long the TV waits before it turns off.

Schedule Leads to a control panel that lets you set up a schedule for turning the TV on and off automatically. The on-screen directions guide you through the steps needed to set the schedule.

Set Time and Day Leads to a control panel that lets you enter the current time and current day of the week. The on-screen directions guide you through the steps needed to set the time and day.

Time Display Lets you choose how the TV's clock is displayed. The clock can appear in the upper right corner of the main picture; it can appear every 60, 30, or 15 minutes for four seconds; or it can be off entirely.

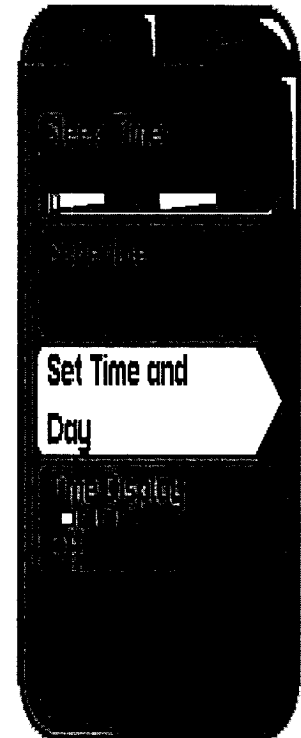

QUICK REFERENCE

CHANNEL MENU

Parental Control

Lets you turn the Parental Control feature off or on. You indicate which channels are Parent Approved in the Lists and Labels control panel, explained below.

On The front panel CHAN buttons will tune only to channels that you have marked as "Parent Approved" in the Lists and Labels control panel (see below). **Important:** When Parental Control is on, the TV's front panel no longer provides access to the menus. Parents may prefer to hide the remote and let children use the front panel to change channels.

Off The TV shows all channels, whether they are marked as "Parent Approved" or not. Front panel access to menus is available when Parental Control is set to Off.

Signal Source Lets you indicate whether you are currently using a signal plugged into the Antenna A or Antenna B jacks on the back of the TV. Usually, the antenna or cable is connected to Antenna A.

Signal Type

Lets you select which type of TV signal you are currently using.

UHF/VHF Antenna Choose if you are currently using an antenna for TV signals.

Cable Choose if you are currently using cable or a cable box for TV signals.

Lists and Labels

Leads to a control panel that lets you choose whether to include each channel in various lists: a list of normally available channels, a list of favorite channels, a list of parent approved channels, and a list of channels that will be accompanied by dialog in a second language, if available. Also lets you assign easily-remembered labels to the channel numbers.

CHAN Use the MOVE arrows to move up and down through the channel scan list.

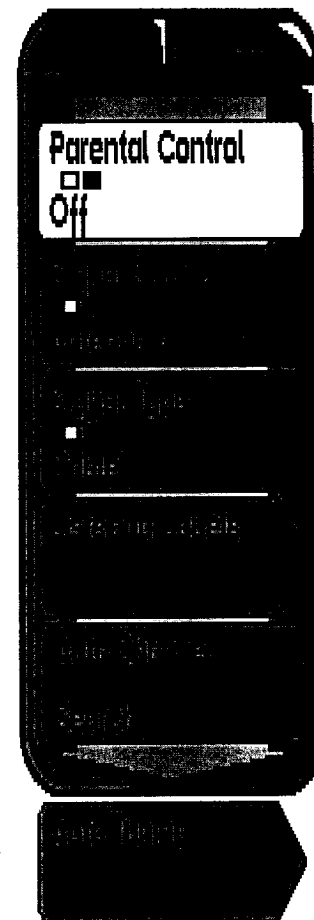

Connect your video game to Antenna B. Then, when you want to play video games, press ANTENNA on the remote to change the Signal Source to Antenna B.

You may prefer to include only a dozen or so of your favorite channels in the Normal list, and use the number buttons on the big remote to access the rest of the channels as desired.

QUICK REFERENCE

NORM All the channels that have Normal checked make up the Normal list. These channels can be viewed by scanning with the CHAN buttons, if the Normal viewing list is selected in the Options control panel in the Screen menu. In Normal viewing, channels that are not part of the list can be viewed by using the number buttons on the remote. Use the MENU button to check or uncheck the Normal box for a channel.

FAV All the channels that have Favorite checked make up the Favorite list. You can place 10 channels in the FAV list.

Parent Approved Use the MENU button to check or uncheck the Parental Control box for a channel. A check indicates that the channel can be shown at any time, regardless of whether Parental Control is turned on. No check indicates that the front panel cannot tune to that channel when Parental Control is turned on. **Important:** You must turn the Parental Control feature to On.

SAP (Second Audio Program) When this is chosen for a channel, the channel's dialog is in a second language, if a second-language audio signal is available. The TV displays the word SAP when you tune to a program that is broadcast with SAP information. SAP audio is broadcast in mono.

Labels Use the MOVE arrows to enter a six-character custom label for each channel. Hold the button down to scroll quickly through the characters—there are a lot of them. Press RESET to clear a label. **The TV can store at least 24 labels in memory.** You may wish to use the graphic logos for most channels and use the custom labels for special channels.

Auto Channel Search Tells the TV to search automatically for all the channels available through the antenna input(s). When the TV finds an active channel, it places it in the Normal channel list. Inactive channels—weak stations or channels with no signal at all—are removed from the channel list. VIDEO 1 is automatically placed in the Normal channel list. If the VIDEO 2 and VIDEO 3 inputs were assigned to a device, they are added to the Normal channel list also.

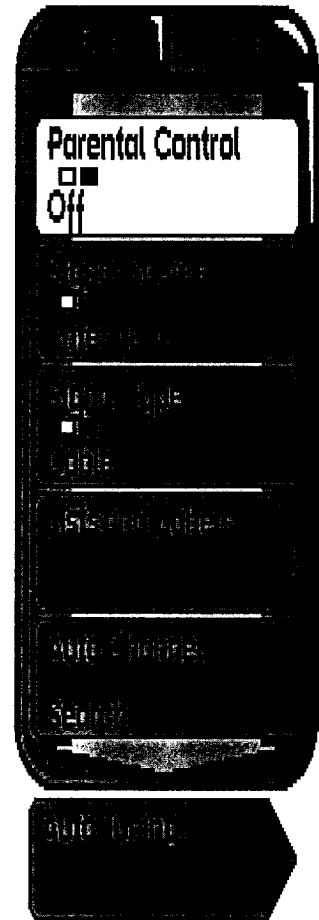

QUICK REFERENCE

AUTO TUNING

Leads to a menu that lets you set up the TV to automatically tune to the correct input channel when you press VCR1, VCR2•LD, or DSS•CABLE.

Set VCR 1 Channel

Lets you select the channel that the TV tunes to when you press the VCR1 button. The choices are:

Not Connected Choose this if you do not have a VCR connected to an antenna or Video input on the back of the TV, or if you don't want the TV to tune to a channel when the VCR1 button is pressed.

Channel 3 Antenna A Choose this if your VCR is connected to the Antenna A jack on the back of the TV, and you want the TV to tune to channel 3 when you press the VCR1 button. Reminder: Make sure the component's Ch 3/4 switch is set to channel 3.

Channel 4 Antenna A Choose this if your VCR is connected to the Antenna A jack on the back of the TV, and you want the TV to tune to channel 4 when you press the VCR1 button. Reminder: Make sure the component's Ch 3/4 switch is set to channel 4.

Channel 3 Antenna B Choose this if your VCR is connected to the Antenna B jack on the back of the TV, and you want the TV to tune to channel 3 when you press the VCR1 button. Reminder: Make sure the component's Ch 3/4 switch is set to channel 3.

Channel 4 Antenna B Choose this if your VCR is connected to the Antenna B jack on the back of the TV, and you want the TV to tune to channel 4 when you press the VCR1 button. Reminder: Make sure the component's Ch 3/4 switch is set to channel 4.

Video 1 Input Choose this if your VCR is connected to the Video 1 jacks on the back of the TV, and you want the TV to tune to Video 1 input when you press the VCR1 button.

Video 2 Input Choose this if your VCR is connected to the Video 2 jacks on the back of the TV, and you want the TV to tune to Video 2 input when you press the VCR1 button.

Video 3 Input Choose this if your VCR is connected to the Video 3 jacks on the back of the TV, and you want the TV to tune to Video 3 input when you press the VCR1 button.

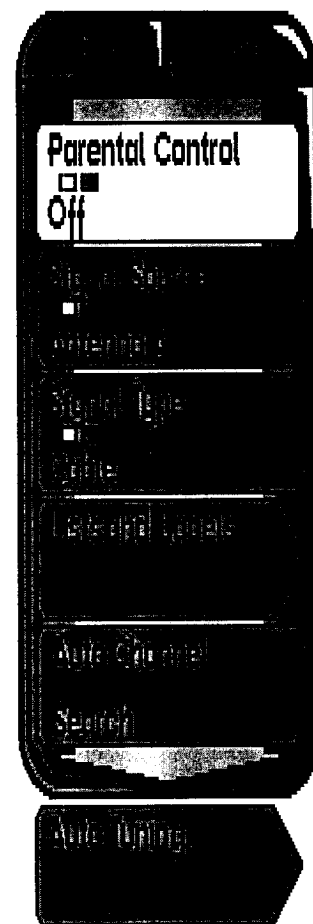

QUICK REFERENCE

Set VCR2•LD Channel

Lets you select the channel that the TV tunes to when you press the VCR2•LD button. The choices are the same as those listed under Set VCR 1 Channel, except that the component is the second VCR or laserdisc player, and the remote button being programmed is VCR2•LD. For example:

Video 2 Input Choose this if your second VCR or laserdisc player is connected to the Video 2 jacks on the back of the TV and you want the TV to tune to Video 2 input when you press the VCR2•LD button. This is a typical setting for a second VCR or laserdisc player.

Set DSS•CABLE Channel

Lets you select the channel that the TV tunes to when you press the DSS•CABLE button. Usually, DSS•CABLE can control either a DSS receiver connected to the Video 1 input jacks or a cable box connected to the Antenna A jack.

The choices are the same as those listed under Set VCR 1 Channel, and include Channel 2 Antenna A and Channel 2 Antenna B. Also, the component is either a DSS Receiver or a cable box, and the button being programmed is DSS•CABLE. For example:

Video 1 Input Choose this if your DSS Receiver is connected to the Video 1 jacks on the back of the TV and you want the TV to tune to Video 1 input when you press the DSS•CABLE button. This is the typical setting for a DSS Receiver.

The following is an example for a cable box:

Ch 3 Antenna A Choose this if your cable box is connected to the Antenna A jack on the back of the TV and you want the TV to tune to channel 3 when you press the DSS•CABLE button. This is a typical setting for a cable box.

QUICK REFERENCE

ASSISTANCE

Setup The Setup routine is part of the Assistance menu and is described in *Interactive Setup*.

Connections Helps you connect different components to the TV. The Connections routine is also part of the setup routine. When you are using the Connections routine, be sure and follow along in the Connections Foldout.

Preferences

Lets you set your preferences for things such as the appearance of the on-screen menus.

Menu Display Lets you change the appearance of the Main Menu. Choose the family room with Nipper (Pictorial) or choose one more like the other on-screen menus (Textual).

Display Size Lets you choose extended or reduced graphics for the on-screen displays. Reduced graphics eliminates the context-sensitive help bar which appears at the bottom of the screen, the mute indicator which appears on screen when mute is active, the volume indicator and many other graphics.

Display Colors Lets you choose what eye-pleasing palette of colors will be used for the on-screen menus. Choose from Cornflower, Sandstone, Seafoam or Charcoal.

Clock Style Lets you change the appearance of the clock that hangs on the wall in the main menu living room. Choose an analog or digital clock.

About Your TV

Gives on-line information about using your TV and about your remote controls.

Guided Tour Provides an automatic tour through the TV's features and menu system. Follow the on-screen directions to step through the different sections, or sit back and enjoy the show.

Remote Control Shows the remote control you are currently using—the universal or the simple remote—and explains the function of each of the buttons as you point to them.

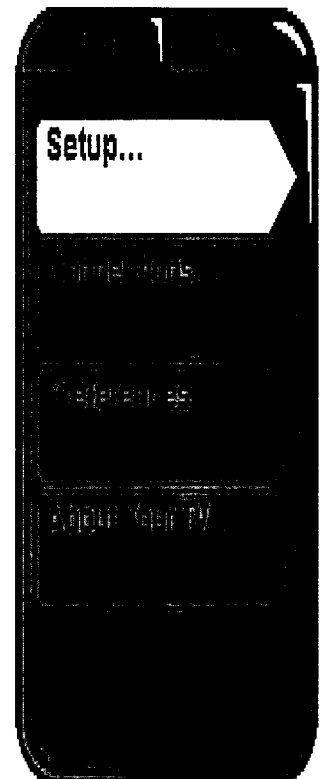

ADVANCED FEATURES

This sections details how to use six of the TV's important features:

- **Operating PIX+**
- **Using closed captioning**
- **Adjusting Projection TV**
- **Displaying on-screen program details**
- **Choosing an audio processor**
- **Using Fetch**
- **Displaying on-screen help**

The *Quick Reference* contains more information about the different menus, controls and control panels.

ADVANCED FEATURES

PIX+ OPERATION

There are four different PIX + modes: PIP (picture-in-picture), Split Screen, POP (picture-outside-picture) and Channel Guide. You can access all of these modes through the Screen menu.

PIP Mode (picture-in-picture) Displays a second, smaller picture on top of the main picture.

Split Screen Mode Divides the main picture into left and a right pictures.

POP Mode (picture-outside-picture) Displays three small pictures to the right of the main picture.

Channel Guide Replaces the large picture with 12 small pictures.

PIX + with remote control buttons

The following remote control buttons affect the PIX+ modes:

PIP Brings up the PIP window. Press PIP again to remove the window.

SPLIT Brings up the Split Screen. Press SPLIT again to remove the Split Screen.

POP Brings up the POP windows. Press POP again to remove the windows.

Guide Brings up 12 windows. Press Guide again to remove the windows.

CH CTRL (Channel Control) Selects whether the main picture or a PIX+ window is affected by the CHAN^ and CHAN v button. For instance, press PIP to bring up the PIP window, then press CH CTRL. Now, when you press the CHAN buttons, the channels will change in the PIP window, not the main picture.

In PIP and Split Screen modes, CH CTRL switches between the main picture and the PIX+ window. In POP mode, CH CTRL switches from main picture to top window to middle window to bottom window and back to main.

FREEZE Freezes the video in the main picture or PIP window. To change which window is currently selected, use CH CTRL.

SWAP In PIP or Split Screen mode, switches, or "swaps" the video display from the PIX + window to the main picture.

SIZE In PIP mode, selects the size of the PIP window. Choose from five sizes.

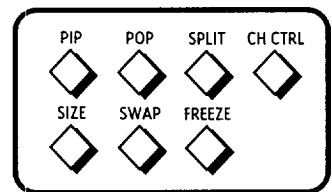

You can scan through channels in the PIP window. When you find a channel you like, press SWAP to display that channel in the main picture, sending the current channel to the PIP window.

ADVANCED FEATURES

SCAN Pressing SCAN causes the TV to automatically scan through your channel list, using the currently selected window. To change the currently selected window, use CH CTRL. Each channel is displayed for four seconds before the TV automatically tunes to the next channel in the list. In channel guide mode, you can highlight one of the 12 windows and press Scan to freeze the other 11 windows and run the selected window.

Move Buttons In PIP mode, you can use the move buttons to push the PIP window to different positions on the screen.

TWO TIPS FOR USING PIP + BUTTONS

Automatic Channel Surfing during commercials in the Main Picture

You can auto-surf through the channels during commercials using the SKIP and SCAN buttons.

1. Press SKIP to set the commercial skip timer. The PIP window appears.
2. Then, press SCAN to auto-surf the main picture through the channel list. When the SKIP feature times out, the original channel will return automatically to the main picture and the PIP window disappears.

Automatic Channel Surfing in the PIP Window

You can use the PIP window to auto-surf through channels as well.

1. Press PIP to bring up the PIP window.
2. Press CH CTRL to move the channel control to the PIP window.
3. Press SCAN. The TV begins displaying each channel in the PIP window. If you see a channel that interests you, press SWAP.

ADVANCED FEATURES

CLOSED CAPTIONING

Many programs are encoded with closed captioning information, which lets you display the audio portion of a program as text on the TV screen. You can tell the TV to display closed captioning: a) never, b) whenever it is available, or c) whenever the audio is muted.

TO DISPLAY CLOSED CAPTIONING

1. Press MENU to bring up the Main Menu.
2. Point to Screen and press MENU. The Screen Menu appears with PIX+ highlighted.
3. Point to Closed Cap Disp.
4. Press the move buttons to select a closed captioning display:
 - Off** No closed captioning information is displayed.
 - On always** Closed captioning is displayed whenever it is available.
 - On when muted** Closed captioning is displayed only when you have muted the sound.
5. Point to Exit and press MENU to return to the Main menu.

Closed captioning is not available on all channels at all times. Only specific programs encoded with closed captioning information are applicable. When a program is closed captioned, the letters CC are displayed in the channel marker.

ADVANCED FEATURES

CLOSED CAPTIONING MODES

The TV offers eight closed-captioned modes, including four text modes.

To Set the Closed Captioning Mode

1. Select Screen from the Main Menu.
2. Point to Closed-Captioned Mode.
3. Use the move arrows to select your choice.
4. Select Exit to return to the Main menu.

TURNING OFF CLOSED CAPTIONING

1. Select Screen from the Main Menu.
2. Point to Closed Cap Disp.
3. Use the move arrows to highlight the OFF toggle and select it. The closed captioning turns off.
4. Select Exit to return to the Main menu.

If you are unsure of the differences among the modes, you may prefer to leave the closed captioned mode set to CCI, which displays complete text of the program in the primary language in your area.

ADVANCED FEATURES

ADJUSTING PROJECTION TV

Your projection TV has three color projection tubes—one for red, one for green, and one for blue. When the tubes are precisely aligned they create the color images you see on the TV screen. Over time, the picture can drift out of alignment due to normal bumps and vibrations or moving the TV. If you notice colored rings or halos around objects in the picture, you may want to adjust the picture tubes.

1. Press MENU to bring up the Main Menu.
2. Point to Screen and press MENU. The Screen Menu appears with PIX+ highlighted.
3. Point to Adjust Projection TV.
4. Use the move arrows to select a color to adjust, red or blue. The green projection tube remains stationary.
5. A test pattern appears on the screen. Adjust the colors until the grid lines appear white.
6. Point to Exit and press MENU to return to the Main Menu.

ADVANCED FEATURES

ON-SCREEN PROGRAM DETAILS

Program providers have the option of sending information through the airwaves along with their programs. If this information is available, the TV can display it when you press DISPLAY. To display the on-screen program details:

1. Press DISPLAY once to bring up the channel marker.
2. Press DISPLAY again to bring up the program title and the program's length and elapsed time.
3. Press DISPLAY again for other program details such as the story line and whether Closed-Captioning is available.
4. Press DISPLAY again to clear the screen.

Whether all (or any) of the program details are displayed depends on whether the program provider sends the information along with the program.

ADVANCED FEATURES

CHOOSING AN AUDIO PROCESSOR

Changing the audio processor changes the way your TV sounds. There are two ways to change the audio processor: from the Audio menu or by pressing SURROUND on the remote. For more information, see *Audio Menu*.

Choosing an audio processor from the Audio Menu

1. Press MENU to bring up the Main Menu.
2. Press MENU again to select the Audio menu.
3. Point to Audio Processor.
4. Use the move arrows select an audio processor: Mono, Stereo, Dolby 3, Pro Logic Phantom, Pro Logic, Matrix Surround, and Hall Surround. These options are described on page 40.

Choosing an audio processor from the remote

1. Press SURROUND to display the current audio processor mode on the screen.
2. Press SURROUND repeatedly to toggle through the different audio modes. The TV displays the name of the current audio processor mode each time you press SURROUND.



The number of audio processor choices available depends on the speaker configuration you are currently using. For example, you can only use the Pro Logic audio processor when you have left, right, center and external rear speakers.

ADVANCED FEATURES

USING AND MODIFYING FETCH

Using Fetch

To use the commands currently stored in Fetch:

1. Press the Fetch button during normal viewing. The Fetch menu appears. By default, the menu includes the Sleep Timer slider from the Time menu, the Audio Processor toggle from the Audio menu, the Contrast slider from the Picture Quality menu, and the Closed Cap Disp toggle from the Screen menu.
3. To use the Contrast command, highlight *Contrast* and move the contrast slider as you would if it were in its usual menu.
4. Point to *Exit* and press MENU to return to normal viewing.

Every command you find in the Fetch menu behaves just as it would in its usual menu.

Modifying Fetch

You can add a new command or replace existing commands in the Fetch menu. For example, to add the Equalizer command to the Fetch menu:

1. Press MENU to bring up the Main Menu.
2. In the family room, point to one of the speakers and press MENU. The Audio menu appears.
3. Highlight *Equalizer*.
4. Press FETCH. The Fetch menu appears, and the Equalizer command appears to the right of the menu.
5. There are 5 slots in the FETCH menu. To place the Equalizer control panel in one of the slots, highlight the slot and press MENU. A message appears telling you the command is in place.
6. Press MENU again.
7. Press CLEAR. You are returned to normal viewing.

Not all command menus can be placed in the Fetch menu.

ADVANCED FEATURES

DISPLAYING ON-SCREEN HELP

When you are at the Main Menu—the family room—press Help in the upper left corner of the family room to display reminders of the locations of all available menus.

Menu Help

Every menu has a Help command. If you select it, detailed information appears about the choices available in that menu.

For example,

1. Press MENU to bring up the Main Menu.
2. In the family room, point to the remote control and press MENU. The Channel menu appears.
3. Use the move buttons to point to Help and press MENU. Helpful information relating to the Channel menu appears.

Context Sensitive Help

This ProScan TV also provides Context-Sensitive Help. The TV knows the buttons you press and will offer information tailored to your needs. To use Context-Sensitive Help:

1. Press MENU to bring up the Main Menu.
2. In the family room, point to the screen and press MENU. The Screen menu appears.
3. Point to a command, *Closed Cap Disp* for example.
4. Helpful information about the command appears in the lower right of the screen. For example, if you highlighted *Closed Cap Disp*, this message appears at the bottom of the screen:

**Press < or > to turn the display
on, off, or on when sound is muted.**

**If you select the reduced graphics
option in the Assistance menu, the
context sensitive help is not displayed.**

APPENDICES

THINGS TO KNOW BEFORE CONNECTING COMPONENTS

Protect your components from power surges

- Connect all components before plugging any power cords into the wall outlet.
- Always turn off the TV and/or component before you connect or disconnect any cables.

Position cables correctly to avoid audio hum or interference

- Insert all cable plugs firmly into their jacks.
- Place the audio/video cables to the sides of the TV's back panel instead of straight down the middle after you connect your components.
- Try not to coil any twin-lead cables and keep them away from the audio/video cables as much as possible.
- Make sure all antennas and cables are properly grounded. Refer to the Safety Tips sheet packed with your TV.

Protect your components from overheating

- Do not block ventilation holes in any of the components. Arrange the components so that air can circulate freely.
- Do not stack components.
- Allow adequate ventilation when placing your components in a stand.
- Place an amplifier on the top shelf of the stand so heated air rising from it will not flow around other components.

Connect audio/video cables for best results

- Required for picture-in-picture feature.

This section assumes that you have already accomplished two tasks:

- a) Used the Interactive Setup
- b) Programmed the remote

APPENDIX A: USING CONNECTION A

TV ONLY

This information applies to Connection A in the Connections Foldout.

Connection A provides:

- stereo sound from broadcast programs
- Picture in Picture (PIP)

To use this connection you must have:

- (1) coaxial cable

To connect:

1. Connect cables as shown in Connection A.
2. Return to *First Things First*, then follow the steps in the Interactive Setup.

USING CONNECTION A

To watch TV programs:

1. Press TV and tune to a channel.

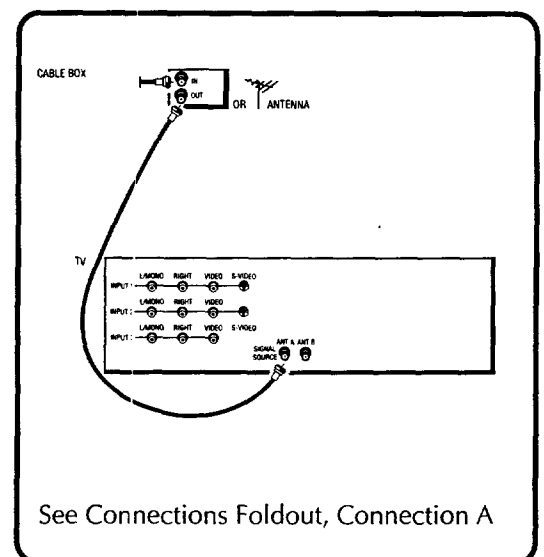

APPENDIX A: USING CONNECTION B

TV AND MONO VCR

This information applies to Connection B in the Connections Foldout.

Connection B provides:

- stereo sound from broadcast programs
- mono sound from VCR
- Picture in Picture (PIP)
- viewing one channel on TV while recording another channel

To use this connection you must have:

- (2) audio/video cables
- (2) coaxial cables

To connect:

1. Connect cables as shown in Connection B.
2. Return to *First Things First*, then follow the steps in the Interactive Setup.

USING CONNECTION B

To watch TV programs:

1. Turn VCR off.
2. Press TV and tune to a channel.

To record one program and watch another:

1. Press VCR1 and tune to a channel.
2. Begin recording.
3. Make sure the TV/VCR switch on the VCR is set to TV.
4. Press TV and tune to a channel.

To play a tape on the VCR:

1. Press VCR1.
2. Press PLAY.

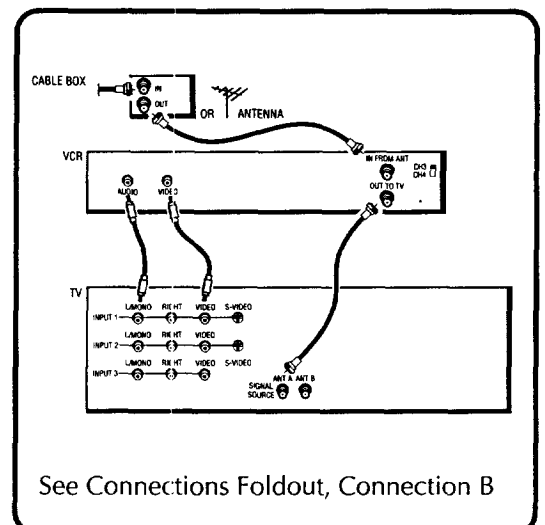

See Connections Foldout, Connection B

APPENDIX A: USING CONNECTION C

TV AND STEREO VCR

This information applies to Connection C in the Connections Foldout.

Connection C provides:

- stereo sound from broadcast programs
- stereo sound from VCR
- Picture in Picture (PIP)
- viewing one channel on TV while recording another channel

To use this connection you must have:

- (2) coaxial cables
- (3) audio/video cables
- (1) S-Video cable (optional)

To connect:

1. Connect cables as shown in Connection C.
2. Return to *First Things First*, then follow the steps in the Interactive Setup.

USING CONNECTION C

To watch TV programs:

1. Turn VCR off.
2. Press TV and tune to a channel.

To record one program and watch another:

1. Press VCR1 and tune to a channel.
2. Begin recording.
3. Make sure the TV/VCR switch on the VCR is set to TV.
4. Press TV and tune to a channel.

To play a tape on the VCR:

1. Press VCR1.
2. Press PLAY.

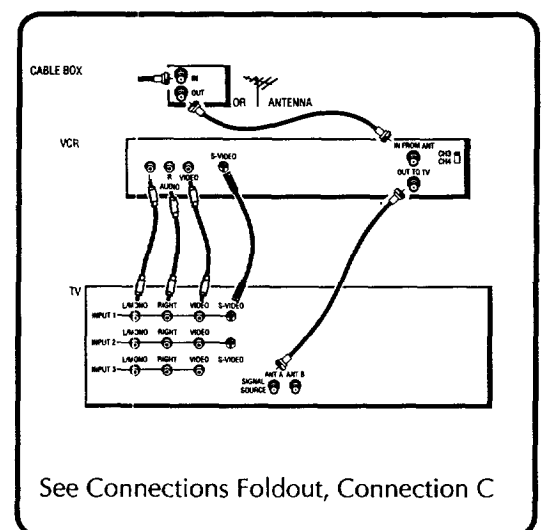

APPENDIX A: USING CONNECTION D

TV AND VCR USING A SPLITTER

This information applies to Connection D in the Connections Foldout.

Connection D provides:

- stereo sound from broadcast programs
- stereo sound from VCR
- Picture in Picture (PIP)
- viewing one channel on TV while recording another channel

To use this connection you must have:

- (1) splitter
- (3) coaxial cables
- (3) audio/video cables
- (1) S-Video cable (optional)

To connect:

1. Connect cables as shown in Connection D.
2. Return to *First Things First*, then follow the steps in the Interactive Setup.

USING CONNECTION D

To watch TV programs:

1. Press TV and tune to a channel.

To record one program and watch another:

1. Press VCR1 and tune to a channel.
2. Begin recording.
3. Press TV and tune to a channel.

To play a tape on the VCR:

1. Press VCR1.
2. Press PLAY.

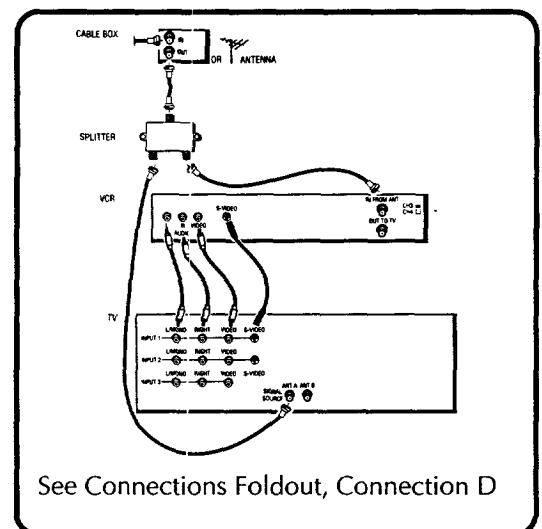

APPENDIX A: USING CONNECTION E

TV AND DSS RECEIVER

This information applies to Connection E in the Connections Foldout.

Connection E provides:

- stereo sound from broadcast programs
- stereo sound from the DSS receiver
- Picture in Picture (PIP)

To use this connection you must have:

- (2) coaxial cables
- (3) audio/video cables
- (1) S-Video cable (optional)

To connect:

1. Connect cables as shown in Connection E.
2. Return to *First Things First*, then follow the steps in the Interactive Setup.

USING CONNECTION E

To watch TV programs:

1. Press TV and tune to a channel.

To watch DSS programming:

1. Press DSS•CABLE and tune to a channel.

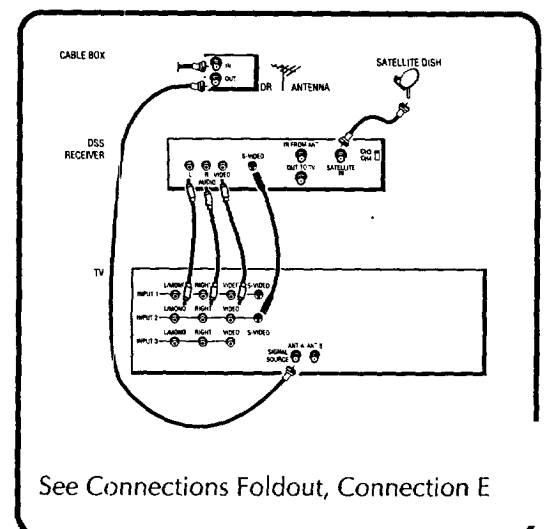

APPENDIX A: USING CONNECTION F

TV, VCR, AND DSS RECEIVER

This information applies to Connection F in the Connections Foldout.

Connection F provides:

- stereo sound from broadcast programs
- stereo sound from VCR
- stereo sound from the DSS receiver

To use this connection you must have:

- (4) coaxial cables
- (6) audio/video cables
- (2) S-Video cables (optional)

To connect:

1. Connect cables as shown in Connection F.
2. Return to *First Things First*, then follow the steps in the Interactive Setup.

USING CONNECTION F

To watch TV programs:

1. Turn off VCR and DSS receiver.
2. Press TV and tune to a channel.

To watch DSS programming:

1. Press DSS•CABLE and tune to a channel.

To record off-air (cable or antenna) broadcasts and watch a different channel:

1. Turn DSS receiver off.
2. Press VCR1 and tune to a channel.
3. Press RECORD to begin recording.
4. To watch another channel, make sure the TV/VCR switch on the VCR is set to TV; then press TV and tune to a channel.

To play a tape on the VCR:

1. Press VCR1 and then press PLAY.

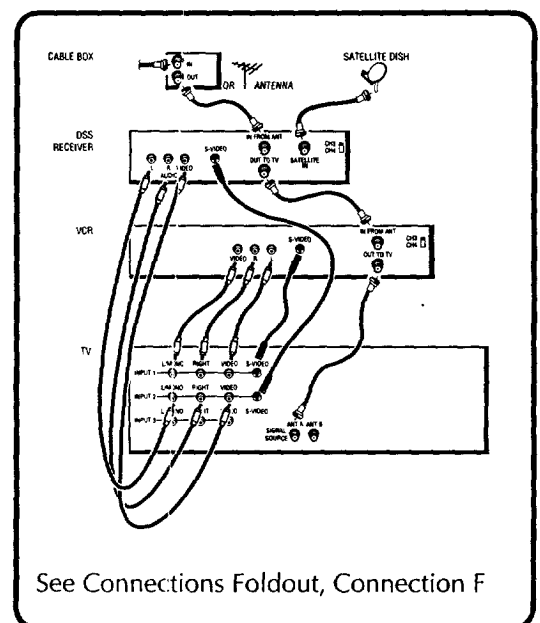

APPENDIX A: USING CONNECTION G

TV, VCR, AND DSS RECEIVER USING A SPLITTER

This information applies to Connection G in the Connections Foldout.

Connection G provides:

- stereo sound from broadcast programs
- stereo sound from VCR
- stereo sound from the DSS receiver
- Picture in Picture (PIP)
- viewing one channel on TV while recording another channel

To use this connection you must have:

- (5) coaxial cables
- (6) audio/video cables
- (2) S-Video cables (optional)
- (1) splitter

To connect:

1. Connect cables as shown in Connection G.
2. Return to *First Things First*, then follow the steps in the Interactive Setup.

USING CONNECTION G

To watch TV programs:

1. Turn VCR and DSS receiver off.
2. Press TV and tune to a channel.

To watch DSS programming:

1. Press DSS•CABLE and tune to a channel.

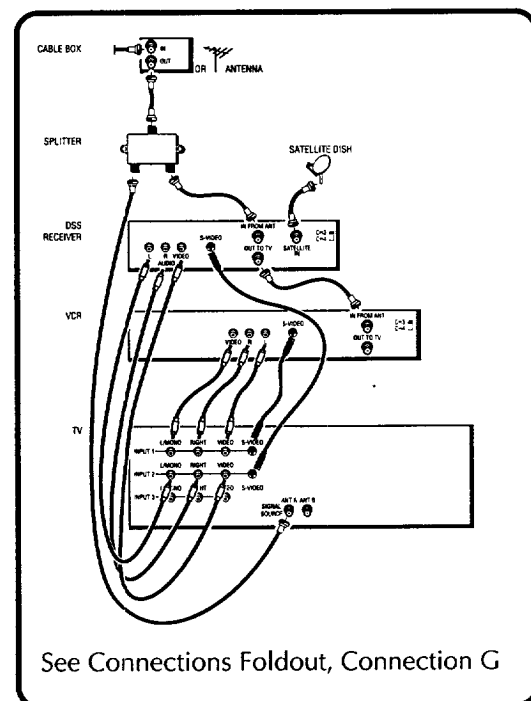

APPENDIX A: USING CONNECTION G

To record off-air (cable or antenna) broadcasts and watch a different channel:

1. Turn DSS receiver off.
2. Press VCR1 and tune to a channel.
3. Press RECORD to begin recording.
4. To watch another channel, make sure the TV/VCR switch on the VCR is set to TV; then press TV and tune to a channel.

APPENDIX A: USING CONNECTION H

To play a tape on the VCR:

1. Press VCR1 and then press PLAY.

ADDING A LASERDISC PLAYER

This information applies to Connection H in the Connections Foldout.

Connection H provides:

- stereo sound from a Laserdisc player

To use this connection you must have:

- (3) audio/video cables

To connect:

1. Connect cables as shown in Connection H.
2. Return to *First Things First*, then follow the steps in the Interactive Setup.

USING CONNECTION H

To play a laserdisc:

1. Press VCR2•LD and then press PLAY.

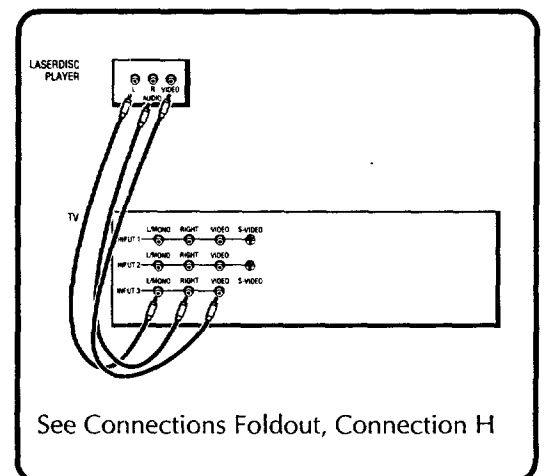

APPENDIX B: CONNECTING EXTERNAL SPEAKERS

CONNECTING EXTERNAL SPEAKERS

You can connect up to six additional speakers to the TV: two to the FRONT SPEAKERS terminals, two to the CENTER SPEAKERS, and two to the REAR SPEAKERS terminals.

Front (Main) Speakers

To connect external speakers:

1. Connect speakers to the MAIN terminals.
2. Set the SPEAKER SWITCH to EXTERNAL.

Center Speakers

To connect external speakers:

1. Connect speakers to the CENTER CHANNEL terminals.
2. Set the SPEAKER SWITCH to EXTERNAL.

Rear Speakers

To connect rear speakers for surround sound effects.

1. Connect two speakers to the SURROUND terminals.
2. Position them behind you in your TV room. To improve the surround sound effect, you may prefer to set or mount the speakers several feet off the ground.

Connecting Speakers to the TV

1. If necessary, remove the vinyl covering from the ends of the speaker wire and twist the wire core.
2. Press down and hold the lever on the speaker terminal.
3. Insert the wire core into the hole. Be sure to connect the (+) to (+) and (-) to (-).
4. Release the lever. Pull gently on the wire to see that it's connected securely.

Connecting a Subwoofer

To connect a subwoofer to the TV:

- Connect the subwoofer's audio input to the left (L/MONO) HI-FI OUT jack.

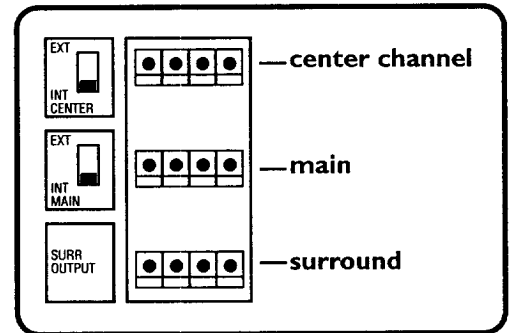

IMPORTANT

When connecting the speaker wire, make sure you connect the positive (+) terminal on the TV to the positive (+) terminal on the speaker. One side of the speaker wire is usually marked with a white stripe to help you match up the terminals correctly. If the (+) and (-) terminals are not matched properly, the speakers will not be "in phase," causing reduction in bass frequencies.

Do not allow the wire core to touch other wires or terminals. Damage to components could result if the cores of two wires touch each other.

APPENDIX B: CONNECTING AUDIO COMPONENTS

CONNECTING AUDIO COMPONENTS

Connecting a stereo amplifier

1. Connect the amplifier's TV audio inputs to the left (L/MONO) and right (R) HI-FI OUTPUT jacks.
2. You may prefer to turn off the TV's internal speakers by selecting a speaker configuration with external speakers from the Audio menu.

If your audio amplifier is part of a system that uses its own remote control, you may prefer to connect it to the TV using the Fixed Output jacks.

Important: Do not use the amplifier's PHONO inputs. If the amplifier is not stereo, use the L/MONO HI-FI OUT jack. Consult the amplifier's owner's manual for the manufacturer's recommended hookup.

Connecting a tape deck

To use a tape deck to record audio from TV:

1. Connect the tape deck's audio inputs to the FIXED OUTPUT jacks on the back of the TV.

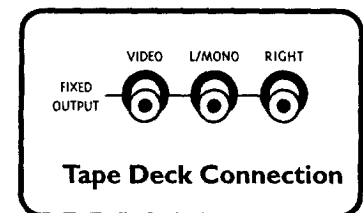

The **FIXED OUTPUT** jacks provide a fixed level audio signal, making them ideal for audio recording, or for use with an audio amplifier that has its own remote control. No matter how the volume changes on the TV, the output volume stays the same.

APPENDIX B: CONNECTING A CAMCORDER

CONNECTING A CAMCORDER FOR PLAYBACK

There are two connections recommended for playing back from the camcorder to the TV:

Front Connection Playback

1. Locate the AV adapter included with your TV accessories.
2. Connect the camcorder's video **output** to the adapter's video input (yellow).
3. Connect the camcorder's audio **output** to the adapter's audio input (white).
4. Connect the adapter to the A•V jack on the front of the TV.
5. Press INPUT on the remote until the channel marker displays FRNT.
6. Start playback on the camcorder.

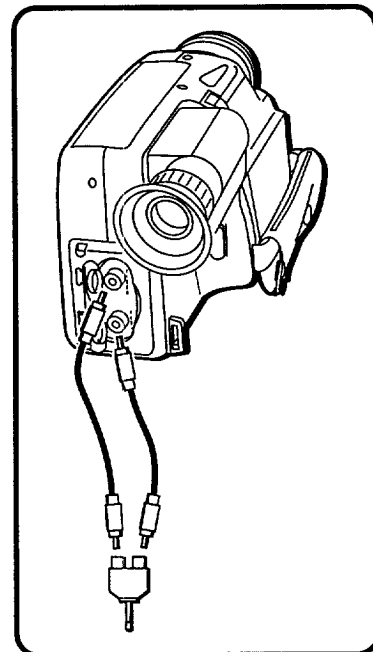

Back Connection Playback

1. Connect the camcorder's audio/video outputs to the INPUT1 audio and video jacks on the TV.
2. Press INPUT on the remote until the channel marker displays VID1.
3. Start playback on the camcorder.

S-VHS CAMCORDER

To connect a camcorder with S-Video capability:

1. Connect an S-Video cable from the camcorder to the S-VIDEO1 jack on the TV.
2. Connect the camcorder's audio/video outputs to the INPUT1 audio and video jacks on the TV.
3. Press INPUT on the remote until the channel marker displays VID1.
4. Start playback on the camcorder.

APPENDIX B: CONNECTING A CAMCORDER

CONNECTING A CAMCORDER TO RECORD FROM THE TV

To record from the TV to the camcorder:

1. Connect the camcorder's audio/video input cables to the TV's **FIXED OUTPUT** jacks.
2. Consult your camcorder's owner's manual for instructions on camcorder recording.

S-VHS Camcorder

The TV does not supply video output in S-Video form. Use the connection described above.

The TV must remain on during recording. If you change channels on the TV, the channel change will be recorded.

Signals from the S-Video connector do not come through the **FIXED OUTPUT video jack. To record to an S-Video component, remember to connect its regular video cable as well as the S-Video cable.**

The PIP window and on-screen menus and displays will not be recorded. If you change channels on the TV, the channel change will be recorded.

APPENDIX C: TROUBLESHOOTING TIPS

TROUBLESHOOTING

Troubles sometimes are caused by simple “faults” that you can correct without the help of a service technician. If you experience any difficulty with your TV, check a few basic remedies before calling your service technician.

TV will not turn on

- Check to make sure it is plugged in.
- Check the wall receptacle (or extension cord) to make sure it is “live” by plugging in something else.
- Maybe batteries in remote control are “dead.”
- Maybe remote control was not aimed at remote sensor.

Controls don’t work

- If using remote control, make sure remote is in TV mode by first pressing TV button.
- Try unplugging set for two minutes and then plug it back in and turn it on again.

Problems with Remote

- Maybe something was between the remote and the remote sensor. Maybe the remote was not aimed directly at the component (TV or VCR) you were trying to control.
- Maybe remote is not in TV Mode. Press the TV button so remote will control TV.
- Maybe batteries in remote are weak or dead or installed incorrectly. Try replacing the batteries.

Remote stops working

- Remove batteries and hold down one or more buttons for several seconds. Install the batteries and try remote.

TV Turns off while playing

- Schedule function may have been activated.
- Electronic protection circuit may have been activated because of a power surge. Wait 30 seconds and then turn on again. If this happens frequently, the voltage in your house may be abnormally high.

Schedule does not turn off the TV at the set time

- Check schedule on/off function (it must be set to On).
- Check to make sure clock is set to the correct time.

APPENDIX C: TROUBLESHOOTING TIPS

Blank screen

- Maybe the device connected to the input jacks is not turned on.
- Try another channel.
- Press RESET, in case the picture controls are set too low.

No sound, picture okay

- Maybe sound is muted. Try pressing volume up button to restore sound.
- Maybe TV's speaker configuration is wrong. Check Speakers command in the Audio menu.
- If using an S-VHS component, remember to also connect the component's L and R AUDIO OUT jacks to the TV's L and R INPUT 1 jacks.
- Maybe SPEAKER switch on the back of the TV is not in the INTERNAL position.

Can't select certain channel

- If using a VCR, check to make sure the TV/VCR switch on the VCR is in the correct position.

Noisy stereo reception

- May be a weak station. Use SURROUND button to change to mono mode instead of stereo.

No picture, no sound but power light is on

- Maybe someone changed cable/air function to wrong position.
- Maybe a vacant channel is tuned. Try another channel.
- If watching VCR (connected only through antenna input), make sure TV is tuned to channel 3 or 4 - same as CH3/4 switch on VCR. Also check to make sure TV/VCR switch on VCR is in correct position.

Sound okay, picture poor

- Check antenna connections.
- Try adjusting Video Noise Filter to improve weak signals.

Black Box appears on the screen

- Captioning may be turned on. Check the Closed-Caption Display control in the Channel Menu.

TV works, can't tune to a channel

- Maybe TV is in FAV Channel mode. Check the Channel List toggle in the Pix+ Options part of the Screen menu.

APPENDIX D: LIMITED WARRANTY

LIMITED WARRANTY

What your warranty covers:

- Any defect in material or workmanship.

For how long after your purchase:

- One year for labor charges.
- One year for parts.
- Two years for picture tube.

The warranty period for rental units begins with the first rental.

What we will do:

- Pay any Authorized PROSCAN Television Servicenter the labor charges to repair your television.
- Pay any Authorized PROSCAN Television Servicenter for the new or, at our option, refurbished replacement parts and picture tube required to repair your television.

How you get service:

- Request home service from any Authorized PROSCAN Television Servicenter. To identify your nearest Authorized PROSCAN Television Servicenter, ask your Dealer, look in the Yellow Pages, or call 1-800-PROSCAN.
- Show the service technician your evidence of purchase date.

What your warranty does not cover:

- Customer instruction. (Your Owner's Manual clearly describes how to install, adjust, and operate your television. Any additional information should be obtained from your Dealer.)
- Installation and related adjustments.
- Signal reception problems not caused by your television.
- Damage from misuse or neglect.
- Remote control batteries.
- A television that has been modified or incorporated into other products or is used for institutional or other commercial purposes.
- A television purchased or serviced outside the USA.
- Acts of God, such as but not limited to lightning damage.

Product Registration:

- Please complete and mail the Product Registration Card packed with your set. It will make it easier to contact you should it ever be necessary. The return of the card is not required for warranty coverage.

How state law relates to this warranty:

- This warranty gives you specific legal rights, and you also may have other rights that vary from state to state.

If you purchased your television outside the U.S.A.:

- This warranty does not apply. See your dealer for details.

APPENDIX E: CARE AND CLEANING

CARE AND CLEANING

You can clean the TV as required, using a soft cloth or the dusting attachment for your vacuum cleaner. Be sure to occasionally vacuum the ventilation slots in the cabinet to help assure adequate ventilation.

To clean the TV screen, use a diluted soap and water mixture and a soft cloth. Do not use furniture polish on the TV cabinet or screen.

While cleaning do not allow liquid to run down the screen and inside the TV. Also, avoid placing drinks or vases with water on top of the TV. This could cause damage to the TV.

INDEX

Symbols

(0-9) 32

A

A•V 38
A•V jack 73
Additional speakers 71
Advanced Features 51
ANT B input, note 36
ANTENNA 33
Arrows 33
Audio component 32
Audio Menu 40
Audio Processor 40
Audio processors 33
Auto Channel Search 17
Auto Color 42
AV adapter 73
AV adaptor 38
AV Jack 38
Available input sources 33

B

Back Panel 36
Back Panel Jacks
 INPUT 1 36
Black Level 42
brightness 42

C

Cable box 25
Care and Cleaning 78
CH CTRL 33
CHAN 32, 43
Change the channel 32
Channel information 32
Channel list 32
Channel Menu 46
Channel menu 8
Channel numbers 32
Choice Lists 13
CLEAR 12, 33
Closed Caption Mode 44
Closed Captioning Display 44
CODE SEARCH 28
Color 42
Color Warmth 42
Connect a camcorder 38
Connecting a Camcorder 72, 73
Connecting a stereo amplifier 72
Connecting a Subwoofer 71

Connecting a tape deck 72
Connecting Audio Components 72
Connecting Speakers 71
Connecting to an A/V receiver 37
Contrast 42
Control Panels 12
 Choice Lists 13
 Sliders 12
Control panels 9
Current channel list 32

D

DISPLAY 32
DSS receiver 32
DSS•CABLE 32
DSS•CABLE button 24, 25

E

Entering channel numbers 32
Equalizer 40
Exit 8

F

Favorite channel list 47
FREEZE 33
FRNT 33
Front Panel 38
Front Speakers 71

G

GUIDE TO THE MENU SYSTEM
 39

H

Hall Surround 40
Headphone 38
Headphone Audio 41
Headphone Volume 41
Home computers, note 36

I

INPUT 33
INPUT 1 36
Input sources 33
INPUT2 36
Interactive Setup 17

K

Key Combination chart 28

L

L/MONO audio jacks 36

M

Main Menu 33
Matrix Surround 40
MENU 13, 33
Menu commands 39
Menu system 9
Menus 9
MOVE 33
MOVE (Arrows) 33
MOVE arrows 8
MUTE 32
Mute 40

N

Number Buttons 32
Numeric entry control panel 14

O

On-screen menus 8
On-screen setup routine 17
Options 43

P

Picture Controls 42
Picture Quality 12
Picture Quality Menu 12,42
Picture-in-Picture 43
Picture-in-picture 33
Picture-outside-Picture 43
PIP 33, 43
PIP window 33
PIX+ 43
Point 8
Point and Select 8
POP 43
PREV CH 32
Previous channel 32
Projection TV adjustment 56
Program information 32
Program the VCR button using CODE
 SEARCH 28
Program the VCR button using DIRECT
 ENTRY 28
Programming the Remote 21
Programming the remote to control a
 laserdisc play 24
Programming the remote to control a
 satellite or c 25, 26

INDEX

Programming the remotes 22
Programming the Simple Remote 28
Programming the universal remote to control a DSS 24
Programming the Universal Remote to Control a VCR 22, 26
Prologic 40

Q

Quick Reference 39

R

Rear Speakers 71
Remote 9
Remote Buttons 32
 VCR1 32
RESET 33
Reset Picture Controls 42
Return to TV 13
REW, PLAY, FF, REC, STOP, PAUSE 32
RIGHT audio jacks 36

S

S-VHS camcorder 73
S-VIDEO 36
SCAN 33
Schedule 45
Select 8
Set Time and Day 45
Set Time numeric entry control panel 14
Sharpness 42
SIGNAL SOURCE 37
Signal Type 13
Signal Type Choice list 13
Simple remote 21
Simple Remote Buttons 34
 CHAN DOWN 34
 CHAN UP 34
 MENU 34
 POWER 34
 TV 34
 VCR 34
 VOL < 34
 VOL > 34
Simple Remote VCR Codes 29
Simple remote's VCR button 28
Single Picture 43
SKIP 32

Sleep Timer 45
Sliders 12
Sound Check 41
Speaker Switch 71
Speakers 40
Split Screen 43
Stereo headphones 38
SWAP 33

T

Theatre 42
Three-digit channel 32
Time Display 45
Time Menu 45
Tint 12
Tour of the TV 31
Transport control 32
TV accessories 38
TV button 32
Tweak 41

U

Universal remote 21, 22
Universal Remote VCR Codes 23

V

VCR Codes 23
VCR mode 32
VCR1 32
VCR1 button 22, 26
VCR2•LD 32
VCR2•LD mode 32
VID1 33
VID2 33
Video games, note 36

ACCESSORIES

Charge your order on your VISA or MasterCard by filling in below

USE YOUR CREDIT CARD

IMPORTANT: Copy complete account number from your VISA card



My card expires:

IMPORTANT: Copy complete account number from your MasterCard



Copy Number above your name on MasterCard: My card expires:

AUTHORIZED SIGNATURE

Prices are subject to change without notice.

PLEASE



Print or type your name and address clearly. This will be your mailing label.

A complete and correct order will save you days of waiting.

Name: _____

Street: _____

_____ Apt: _____

City: _____

State: _____ Zip: _____

To order accessories, contact your local ProScan Dealer.

If a dealer is not nearby, you can also follow the instructions below to order by telephone.

United States and Canadian Orders

To place your order by phone, have your Visa or MasterCard ready and call the toll-free number listed below between 8 AM and 8 PM Eastern Standard Time. **Use this number only to place an order for accessory items listed on this order form.**

1 - 800 - 338 - 0376

Most times your order will be shipped UPS within 72 hours of receipt. If ever it is not possible to ship within 30 days, we will notify you with an update on your order and an option to cancel.

To place your order by mail, detach and mail the completed order form with credit card information, money order, or check in U.S. currency (made payable to Thomson Consumer Electronics, Inc.) to the following address:

ProScan Video Accessories
P.O. Box 8419
Ronks, PA 17573

For more information on these accessories (or current prices), write to the following address:

Video Accessories Customer Service
Thomson Consumer Electronics, Inc.
Distributor & Special Products
2000 Clements Bridge Rd
Deptford, NJ 08096-2088

International Orders

This offer is valid only in the 50 United States and Canada. For international orders, please send your request for quotation (not an order) to:

International Customer Service
Thomson Consumer Electronics, Inc.
Distributor & Special Products
2000 Clements Bridge Rd
Deptford, NJ 08096-2088

ACCESSORIES

Audio/Video Cables *continued*

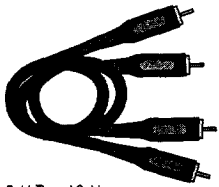

Gold-Tipped Cable
AH072G (3-ft)

Stereo Audio Cable

Double gold-tipped cable generally used for connecting stereo audio components.



186008

S-VHS Video Cable has multipin connectors on each end for connecting S-VHS components to your TV.

Remote Controls

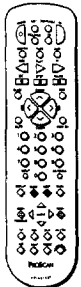

CRK81A



CRK61A

Remote Controls

These are the remote controls that came packed with your TV. Replacements or spares can be ordered as needed.

Accessory Order Form for ProScan TV Models

Description	Part No.	Price	Qty	Total
Signal Splitter	AH047	\$ 3.99		
Gold-Tipped Antenna Cable (6-ft)	AH065G	\$ 6.99		
Gold-Tipped Antenna Cable (10-ft)	AH066G	\$ 8.99		
Gold-Tipped Audio/Video Cable (3-ft)	AH069G	\$ 5.99		
Gold-Tipped Audio/Video Cable (5-ft)	AH070G	\$ 7.99		
Gold-Tipped Stereo Cable (3-ft)	AH072G	\$ 8.99		
Gold-Tipped Dubbing Cable (6-ft)	AH075G	\$ 10.99		
Gold-Tipped Dubbing Cable (6-ft)	AH077G	\$ 14.99		
Screw-on Antenna Cable (3-ft)	AH037	\$ 3.95		
Wireless Headphone System	PSWH100	\$199.95		
S-VHS Cable (8-ft)	VAA020	\$ 29.95		
S-VHS Video Cable (3-ft)	186008	\$ 27.55		
Remote Control (CRK61A)	206799	\$ 28.05		
Remote Control (CRK81A)	225617	\$ 67.90		

Prices are subject to change without notice.	
Total Merchandise (\$10 Minimum Order)	\$ _____
Sales Tax	\$ _____
We are required by law to collect the appropriate sales tax for each individual state, country, and locality to which the merchandise is being sent.	
Shipping, Handling, and Insurance	\$ 5.00
Total Amount Enclosed	\$ _____
Use VISA or MasterCard preferably.	
Money order or check must be in U.S. currency only.	
No COD or CASH.	

All accessories are subject to availability.
Where applicable, we will ship a superseding model.

Detach Here 



ACCESSORY CABLES

General Cable Information

Antenna (or cable-TV) connections are made with either coaxial antenna cable or twin-lead cable. Coaxial cables are shielded so they are less susceptible to hum or interference from adjacent cables.



Slip-on Connector



Screw-on Connector

Round 75-ohm coaxial cable



Flat 300-ohm twin-lead cable

Most audio/video connections between components can be made with shielded audio and video cables that have RCA-type phono connectors.



Standard Audio/Video Cable with RCA-type phono plugs (such as No. AH002)

Color-Coded Jacks

The jacks on the TV's monitor panel are color-coded for ease of use. The VIDEO jacks are yellow, the right AUDIO jacks are red, and the left AUDIO jacks are white. When connecting components to each other, be sure that you always connect left outputs to left inputs and right outputs to right inputs. If a component has only one output (mono), connect it to the R/MONO INPUT jack. To connect S-VHS (Super-VHS) components, an S-VHS video cable is required.



S-VHS Cable (such as No. 186008)

Gold-Plated Jacks and Gold-Tipped Cables

Your ProScan monitor panel is equipped with gold-plated jacks. The gold plating helps prevent oxidation of contacts which provides much less loss than conventional contacts. A complete line of gold-tipped cables is available to help you obtain optimum performance from your equipment.

The following accessories are available from most ProScan dealers and electronics supply stores in case you want to position your components farther apart or need additional cables.

Antenna Cables



AH037 (3-ft)
AH008 (9-ft)



AH004 (5-ft)

Screw-on Cable attaches to the round antenna connectors (called 75-ohm F-type) on the back of your VCR or TV. The ends screw onto the connectors for a secure connection.

Push-on Cable attaches to the round antenna connectors (called 75-ohm F-type) on the back of your VCR or TV. Ends push on for a quick connection.

Audio/Video Cables



AH002 (5-ft)
Gold-Tipped Cables
AH0696 (3-ft)
AH0706 (5-ft)

Audio/Video Cable

Shielded cable for connecting AUDIO and VIDEO jacks. Has an RCA-type phono plug on each end.

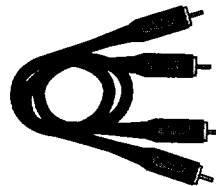

AH005 (6-ft)
Gold-Tipped Cables
AH0756 (6-ft)

Monaural VCR Dubbing Cable Double cable that lets you connect the VIDEO and AUDIO jacks of two VHS VCRs to duplicate tapes. Can also be used to connect a VCR to your TV. Cable is color-coded and shielded. Has RCA-type phono plugs on each end.

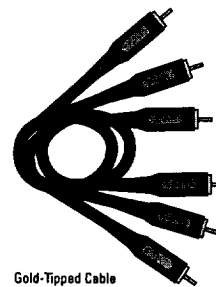

Gold-Tipped Cable
AH0776 (6-ft)

Stereo VCR Dubbing Cable

Triple cable that lets you connect the VIDEO and AUDIO jacks of stereo components.

PROSCAN

We are committed to your complete satisfaction and viewing enjoyment. Any time you have a question or want information about your ProScan product, call our friendly toll-free number listed below. We're always ready to help you Monday through Friday, 9:00 AM to 6:00 PM EST.

**1-800-PROSCAN
(1-800-776-7226)**

**An RCA
Entertainment
Product**

** THOMSON CONSUMER ELECTRONICS
10330 N. Meridian St.
Indianapolis, IN 46209**

©1995 Thomson Consumer Electronics, Inc.
Trademark(s)® Registered
Marca(s) Registrada(s)
Printed in U.S.A.
TOCOM #15083820