

ProV800C

USER'S GUIDE

97100016

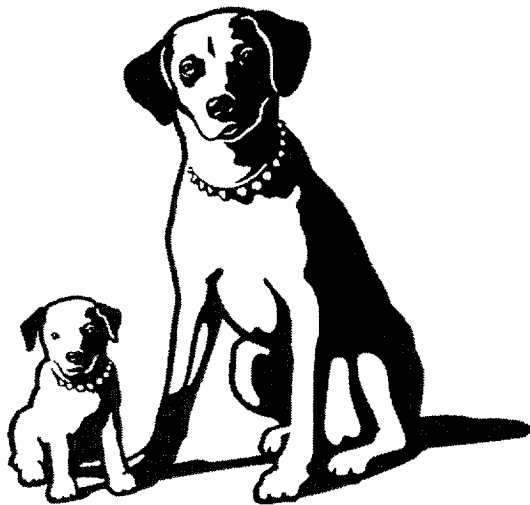

VHSC

C A M C O R D E R

TRISTAR

Important Safety Information

Be sure to read all the safety information before you begin to use this product.

WARNING: To reduce the risk of fire or shock hazard, do not expose camcorder or AC adapter/charger to rain or moisture.

CAUTION

RISK OF ELECTRIC SHOCK
DO NOT OPEN



This symbol indicates "dangerous voltage" inside the product that presents a risk of electric shock or personal injury.

ATTENTION

RISQUE DE CHOC
ELECTRIQUE NE PAS OUVRIR



This symbol indicates important instructions accompanying the product.

TO REDUCE THE RISK OF ELECTRIC SHOCK, DO NOT REMOVE THE COVER (OR BACK). NO USER-SERVICEABLE PARTS ARE INSIDE. REFER SERVICING TO QUALIFIED SERVICE PERSONNEL.

Cautions

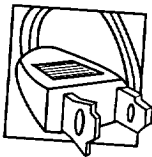

CAUTION: To prevent electric shock, match wide blade of plug to wide slot, fully insert.

ATTENTION: Pour éviter les chocs électriques, introduire la lame la plus large de la fiche dans la borne correspondante de la prise et pousser jusqu'au fond.

To reduce risk of injury, charge only rechargeable batteries recommended by the manufacturer for this camcorder. Other types of batteries may burst causing damage and personal injury.

FCC Regulations state that unauthorized changes or modifications to this equipment may void the user's authority to operate it.

Product Registration

Please fill out the product registration card and return it immediately. Returning this card allows us to contact you if needed.

Keep your sales receipt for proof of purchase to obtain warranty parts and service and attach it here. Record the serial and model numbers located on the bottom of the camcorder.

Model No:

ProV800C

Serial No:

Purchase Date:

Purchased From:

Assistance

We want to make sure you enjoy your new camcorder. If you have any questions, call:

Camcorder Exchange Warranty.....800-283-6503 (pages 90-91)

Customer Service.....800-336-1900 (page 89)

Accessories.....800-338-0376 (pages 76-81)

Table of Contents

Safety Information	i	• Turn off the Camcorder	8
Product Registration	i	• Close Lens Cover and LCD Monitor	8
Table of Contents	1-2	• Review Camcorder's Operating Controls	9-11
First-Time Operation		Powering Your Camcorder	
• Assistance	3	• Using Adapter/Charger	12
• Unpack Camcorder & Accessories	3	• Using Rechargeable Battery	13-15
• Attach the Adapter/Charger	4	• Using Optional Car Cord Adapter ...	16
• Adjust Handstrap	4	Recording Tips	17
• Open Lens Cover	4	Video Cassettes	18-19
• Insert a Tape	5	Recording	
• Turn on Camcorder	5	• Making a Recording	20-23
• Select a Recording Speed	6	• Viewing What You Record Using the LCD Monitor or Viewfinder	24-25
• Set the <i>FULL AUTO/PRESET</i> Switch	6	• LCD Monitor or Viewfinder Displays	26-29
• Use LCD Monitor or Viewfinder to View Recording	7		
• Start and Stop Recording	8		
• Play Back Your Recording	8		

(continued on next page)

Table of Contents

Recording (continued)

• Microphone.....	30
• Flying Erase Head	30
• Auto Head Cleaner	30
• Tally Light.....	30
• Quick Record.....	30
• Tape Positioning.....	31
• Quick Review	31
• Camera Edit	31
• Full Auto Mode	32
• Electronic Indexing	32
• Exposure Control.....	33
• White Balance	34-35
• Focusing	36-37
• Electronic Image Stabilizer	38
• Zooming	39
• Recording Menu	40
• <i>Tele Macro</i> Zooming	41
• <i>Gain Up</i> (Slow Shutter)	42
• <i>Color Filter</i>	43
• Tape Time Remaining Display	44
• <i>Title</i>	45-47
• <i>Date/Time</i> Display	
• Install the Clock Lithium Cell ...	48
• Set the Date and Time	49
• Select Date and/or Time You Want to Record	50-51
• <i>Sub Menu</i>	52
• <i>Tally Light</i>	53
• <i>JLIP ID NO.</i>	53
• Self-Timer Recording	54-55
• Animation Recording	56-57

• Time-Lapse Recording	58-59
• Fading or Wiping In and Out	60-61
• Production Effects	62-63
• Attaching the Shoulder Strap.....	64

Traveling Tips.....65

Playback

• Using the Cassette Adapter...66-67	
• Playback Using the LCD Monitor or Viewfinder	68
• Playback Features	
• Visual Searching.....	69
• Tape Positioning.....	69
• Stop-Action Pause	69
• Time Counter.....	70
• Tracking.....	71
• Playback on TV (or VCR) With <i>AUDIO/VIDEO IN</i> Jacks ...	72-73
• Playback on TV Without Audio/Video Inputs	74-75

Optional Accessories.....76-81

• Accessory Order Form.....	79-81
-----------------------------	-------

Care and Maintenance

Trouble Checks

Specifications

Information to User.....

Customer Assistance and Service ...

Limited Warranty.....

Index (Alphabetical)

First-Time Operation

This section describes only the basic steps necessary to set up your camcorder to record. Refer to the other sections for detailed operation and feature options.

Assistance

The toll-free numbers are available to help you with any problem you may encounter.

Camcorder Exchange Warranty800-283-6503
Customer Service800-336-1900
Accessories800-338-0376

1. Unpack the camcorder and accessories.

- Save the packing materials and box in case you ever need to ship or store your camcorder.
- The items shown below are packed with your camcorder. If any are missing or appear damaged, contact your dealer immediately.

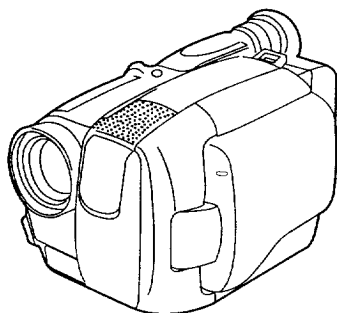

Model ProV800C

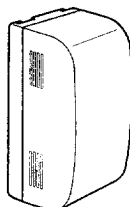

Rechargeable 6-Volt Battery
Part No. 236130

WARNING:
NICKEL
CADMIUM
BATTERY MUST
BE RECYCLED
OR DISPOSED OF
PROPERLY.



Shoulder Strap
Part No. 218858

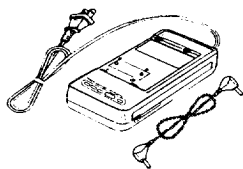

AC Adapter/Charger
Part No. 236689
and DC Cable
Part No. 233087

Caution: Do not use this adapter/charger for any purpose other than charging the 236130, FB1260, or FB120 battery pack or supplying power to the camcorder.

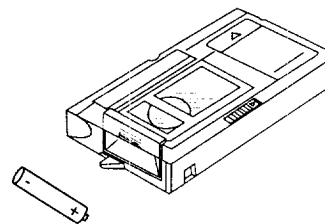

Cassette Adapter
Part No. 237583
Cassette Adapter Battery
(Size "AA" 1.5 Volt)



Clock Cell

3-Volt Micro Lithium Cell – such as CR2025 – available from most local drug stores and camera shops. Use of other cells present a risk of fire or explosion.

Cautions: Lithium cell battery. Must be disposed of properly. Never handle punctured or leaking cell. May cause burns or personal injury. Keep out of the hands of children. Can cause death or injury if swallowed. If swallowed, consult a physician immediately for emergency treatment. The lithium cell used in this device may explode resulting in a fire or chemical burn if mistreated. Do not recharge, disassemble, heat above 212°F (100°C), or incinerate. Never use metallic tweezers to hold the cell, and never short circuit the + and – sides of the cell.

(continued on next page)

First-Time Operation

2. Attach the adapter/charger.

Since the battery must be charged before it can be used the first time, attach the adapter/charger to the camcorder.

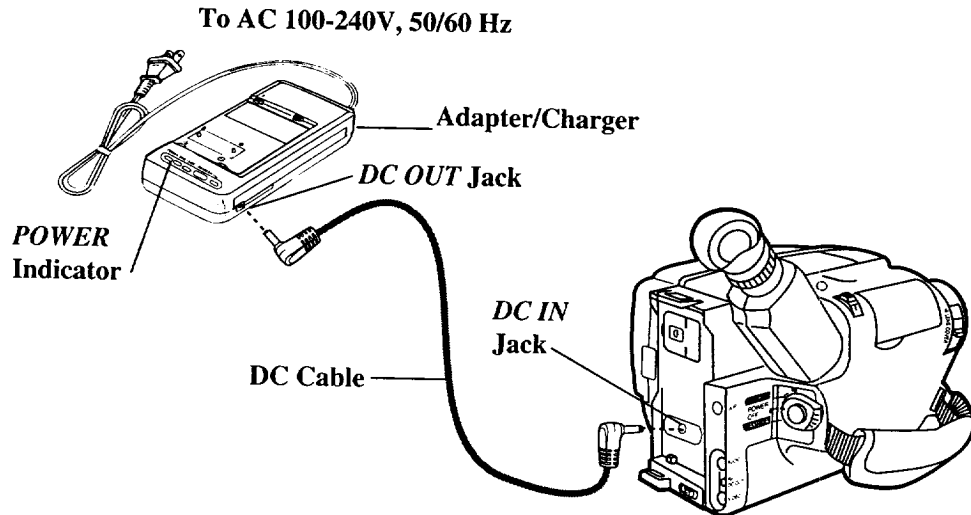

- Connect one end of the DC cable to the *DC OUT* jack on the adapter/charger.
- Connect the other end of the DC cable to the *DC IN* jack on the camcorder *as shown above*.

- Plug the adapter/charger's plug into an operating outlet. The adapter/charger's *POWER* indicator will light

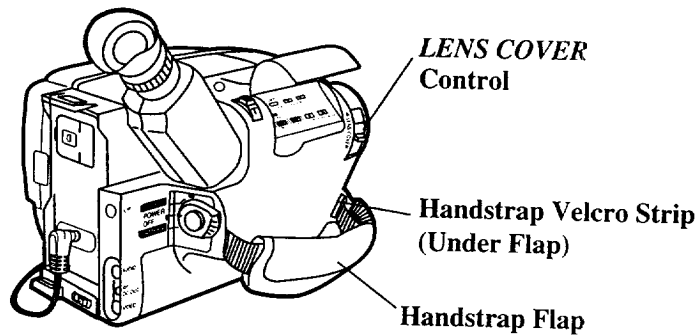

3. Adjust the handstrap to fit your hand.

- Lift the flap on the handstrap and separate the velcro strip.
- Insert your hand, adjust the strap to fit snugly, refasten the strap, and close the flap.

4. Slide *LENS COVER* control to open lens cover.

First-Time Operation

5. Insert a tape.

Caution: Open monitor at least 60° before opening cassette compartment.

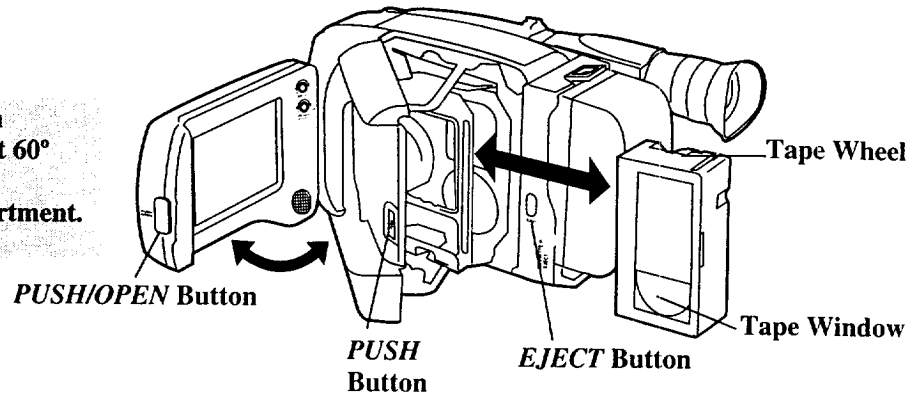

- Press *PUSH/OPEN* to open the LCD monitor. Open the monitor at least 60° before opening the cassette compartment.
- Press *EJECT* to open the cassette compartment.
- Turn the tape wheel on the cassette to remove any slack from the tape.
- Insert the cassette with the tape wheel facing up and the tape window facing out.
- Press the *PUSH* button to lock the cassette compartment closed.

6. Place *POWER (CAMERA/OFF/VCR)* switch in *CAMERA*.

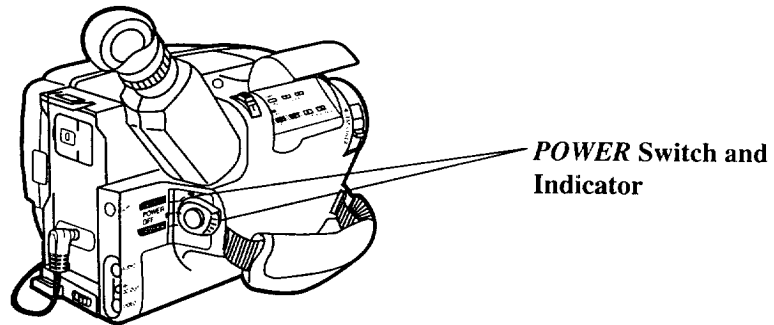

- The power indicator will light and the camcorder will enter record pause. \equiv PAUSE \equiv appears in the viewfinder or LCD monitor when the camcorder is in record pause.
- The position of this switch tells the camcorder whether you want to record (*CAMERA*), turn the power off (*OFF*), or play back tapes (*VCR*).
- The camcorder will automatically turn off if it remains in record pause for five minutes. Place *POWER* in *OFF* and then back in *CAMERA*.

(continued on next page)

First-Time Operation

7. Select a recording speed.

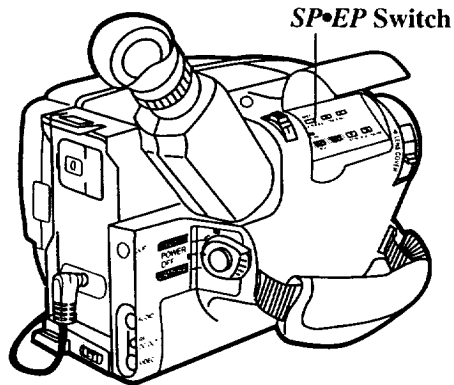

Repeatedly press the *SP•EP* switch to select a recording speed. The indicator for the speed selected appears in the viewfinder and LCD panel.

Select SP or EP recording speed.

- SP – Standard play provides the best picture, but the shortest recording time (20 minutes with a TC-20 tape).

- EP – Extended play provides three times the recording time as SP (60 minutes with a TC-20 tape). EP has slightly more picture noise in normal playback.

Note: The length of the tape you are using must be selected in the recording menu for the camcorder to correctly calculate the recording time remaining on the tape. *Details are on page 44.*

8. Set the *FULL AUTO/PRESET* switch to *FULL AUTO*.

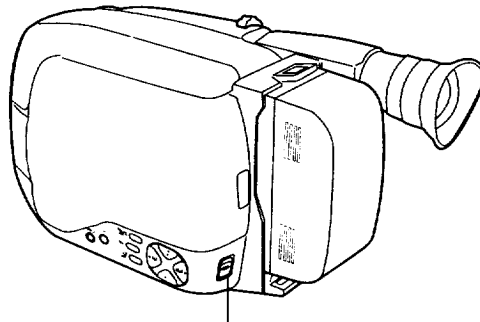

- This places the camcorder in the full auto mode.
- Place the *FULL AUTO/PRESET* switch in *FULL AUTO* to have the camcorder automatically control the focus, exposure, and white balance.

- Many of the special effects do not operate in *FULL AUTO*. *Details on page 32.*

First-Time Operation

9. Use the LCD monitor or viewfinder to view what you are recording.

You can watch what you are recording on the color LCD monitor or in the black-and-white viewfinder. When the LCD monitor is open more than 60°, the viewfinder is automatically turned off. When you close the LCD monitor, the viewfinder is automatically turned on.

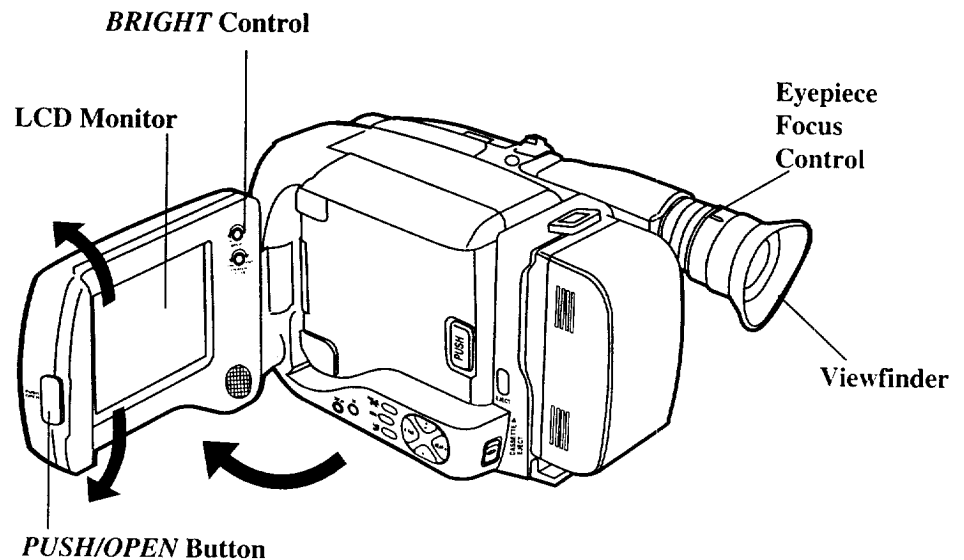

Use the LCD Monitor

- Make sure the monitor is open at least 60°. The viewfinder will be automatically turned off.
- Tilt the LCD monitor (up to 45° up or down).
- Adjust the brightness of the image by turning the *BRIGHT* control.

Note: When recording on a bright sunny day, the LCD monitor may be hard to see. Use the viewfinder.

Use the Viewfinder

- Make sure the monitor is closed and locked. The viewfinder will be automatically turned on.
- Adjust the viewfinder for a comfortable viewing condition.
- Turn the eyepiece focus control to adjust the focus of the viewfinder for your vision.

(continued on next page)

First-Time Operation

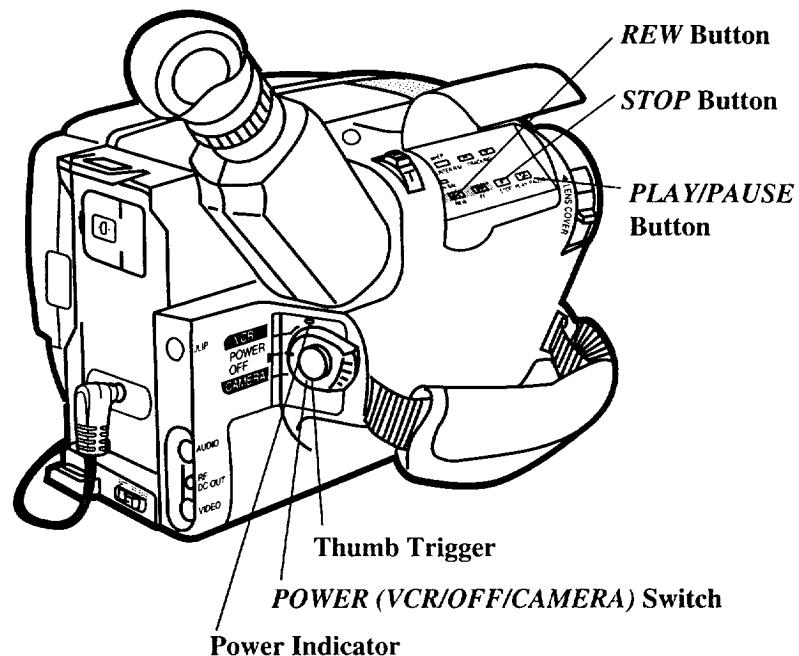

10. Start and stop recording.

- Press and release the thumb trigger to start recording. **REC** appears in the viewfinder or LCD monitor, and the tally light will light when the camcorder is recording.
- Press and release the thumb trigger again to stop recording. The camcorder is now in the record-pause mode. **≡ PAUSE ≡** appears in the viewfinder or on the LCD monitor.

11. Play back what you have recorded.

- Place the *POWER* switch in *VCR*.
- Press *REW* to rewind the tape.

- Press *PLAY/PAUSE* to play back the tape on the LCD monitor or in the viewfinder.
- Press *STOP* when you are finished playing back the tape.
- *Details on viewfinder and LCD monitor playback are on page 68.*

12. Place the *POWER* switch in *OFF* to turn off the camcorder.

The power indicator will turn off.

13. Close the lens cover and close and lock the LCD monitor.

First-Time Operation

14. Review camcorder's operating controls.

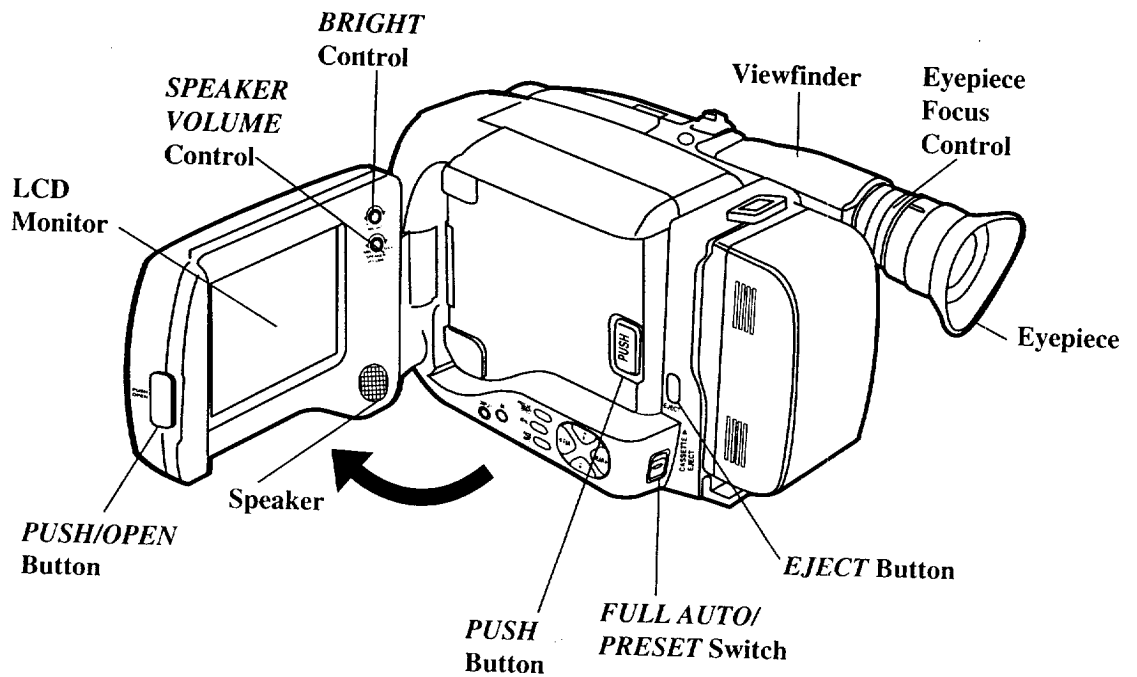
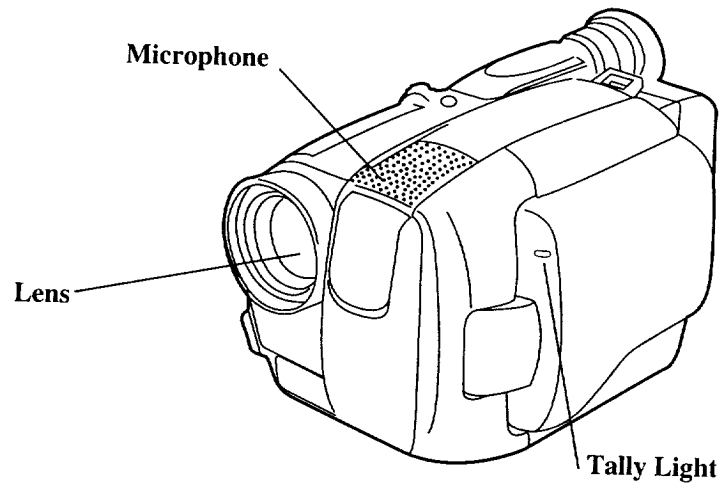

(continued on next page)

First-Time Operation

14. Review camcorder's operating controls. (Continued)

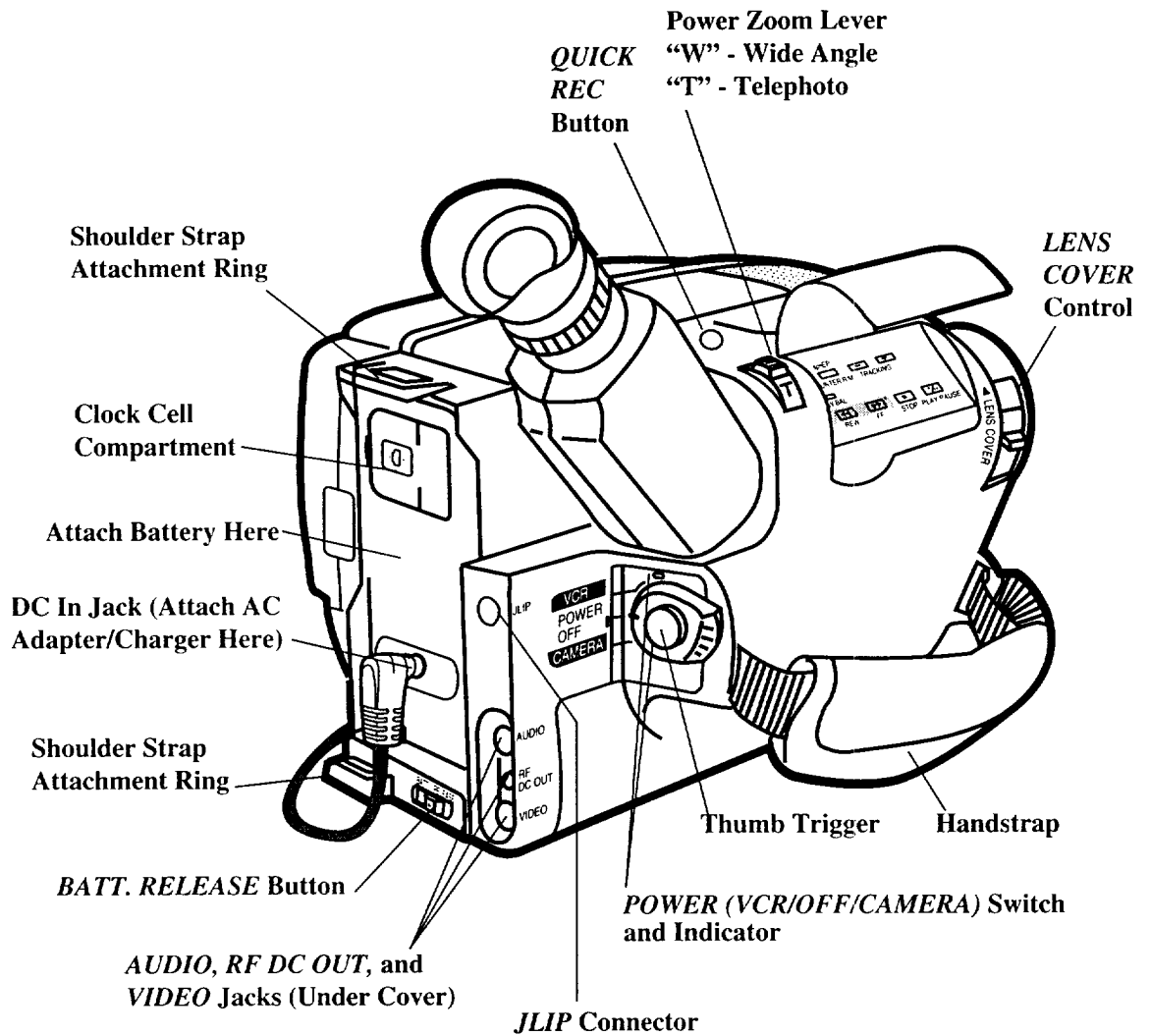

First-Time Operation

14. Review camcorder's operating controls.

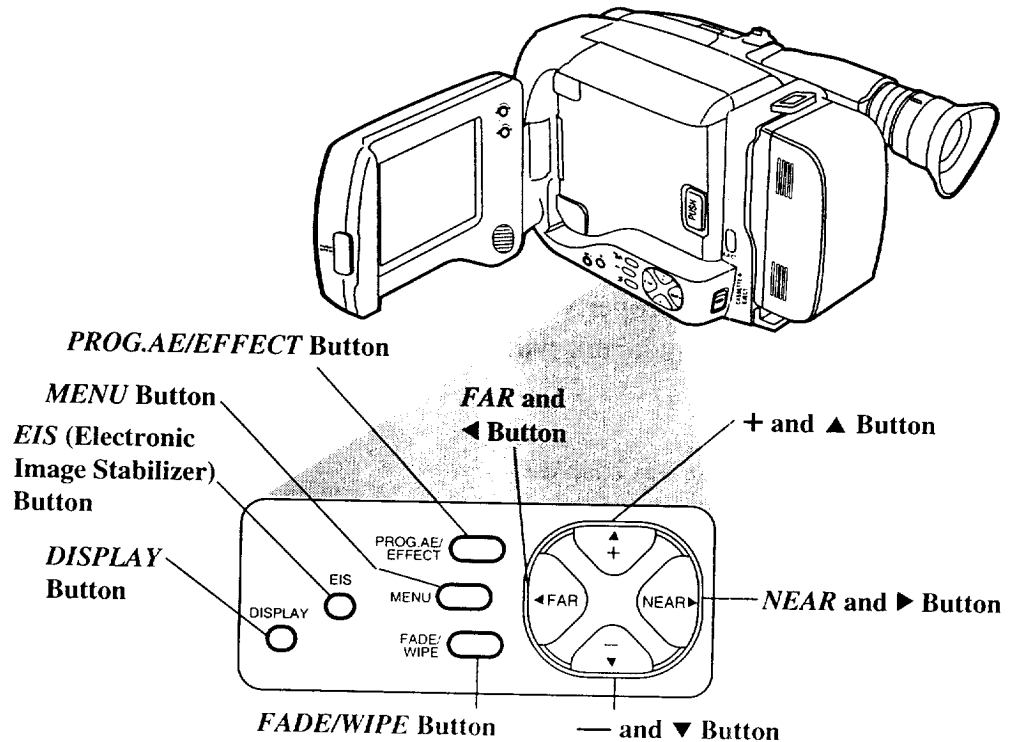
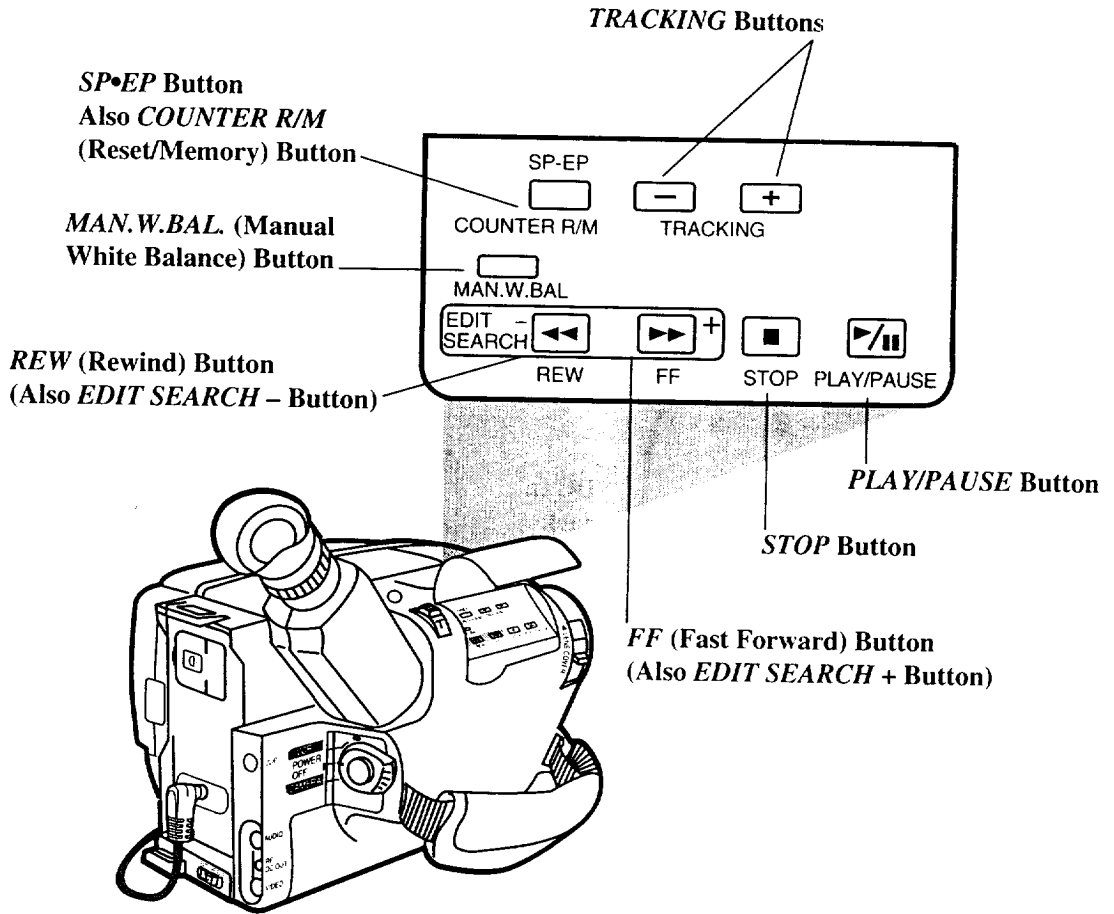

Powering Your Camcorder

Using the Adapter/Charger to Power Your Camcorder

The adapter/charger attaches to the camcorder and lets you power your camcorder directly from standard household power. The adapter/charger operates on 100-240 volts, 50/60 Hz, so it can be used virtually anywhere in the world to power the camcorder or recharge the battery.

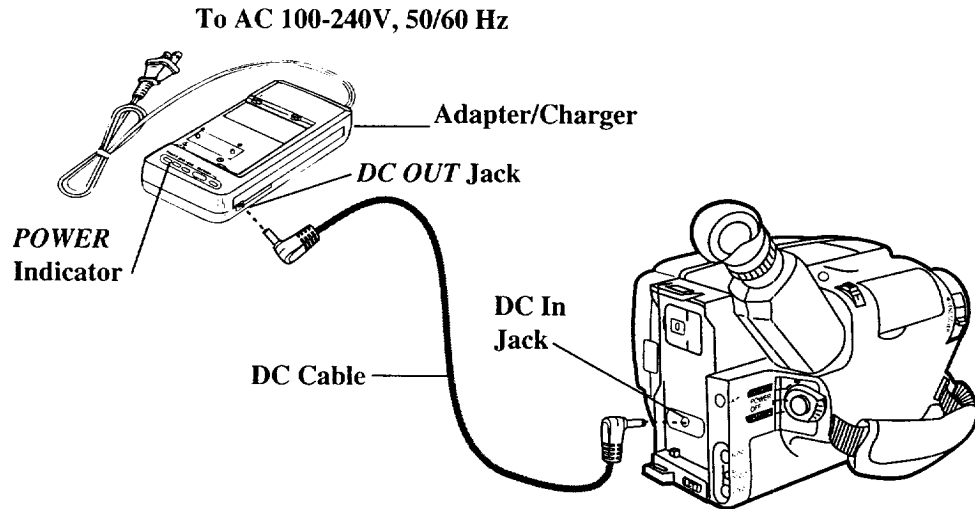

Attach Adapter/Charger

1. Connect one end of the DC cable to the *DC OUT* jack on the adapter/charger.
2. Connect the other end of the DC cable to the DC in jack on the camcorder *as shown above*.
3. Plug the adapter/charger's plug into the nearest AC outlet (100-240V, 50/60Hz).
4. If the adapter/charger is properly connected, its *POWER* indicator will light.

Caution: Do not use this adapter/charger for any other purpose other than charging the 236130, FB1260 or FB120 battery pack or supplying power to the camcorder.

Remove Adapter/Charger

1. Unplug the adapter/charger from the wall outlet.
2. Remove the DC cable from the adapter/charger and camcorder.

Using an Optional Plug Adapter

An optional plug adapter may be required in some countries.

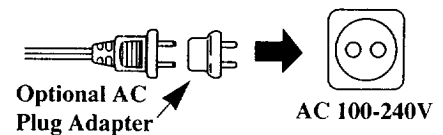

1. Plug the adapter/charger's plug into the AC plug adapter.
2. Plug the AC plug adapter into the AC outlet.

Powering Your Camcorder

Using the Battery to Power Your Camcorder

The battery must be charged *as described on the next page* before it can be used the first time. Initial charging will take approximately 100 minutes. When fully charged, the battery should supply about 75 minutes of operating time (depending on how much you use the LCD monitor, zoom, and pause). Conserve battery power by turning the camcorder off during recording breaks.

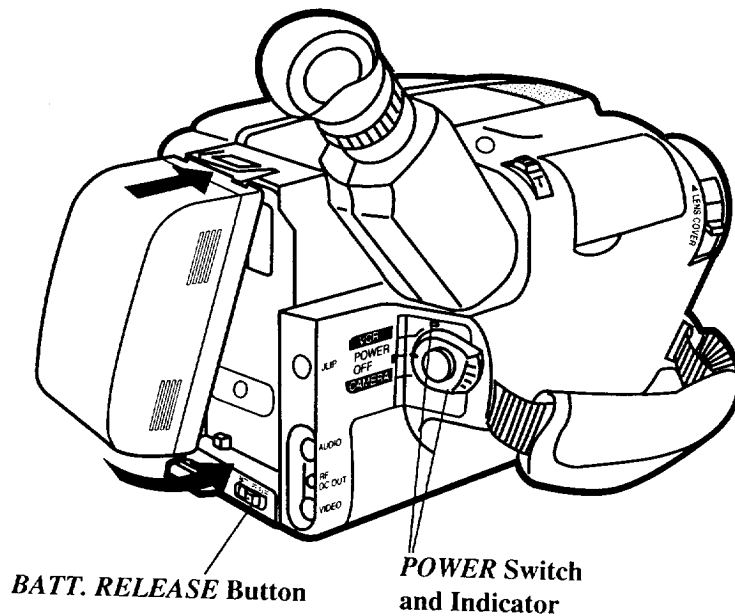

Battery Safety Precautions

Do not short the battery's terminals.

Do not attempt to disassemble or modify the battery. There are no user-serviceable parts inside.

Use the battery only with specified adapter/chargers and camcorders.

Throwing the battery into a fire or exposing it to excessive heat – over 149°F (65°C) could be hazardous.

Attach the Charged Battery

If the DC cable is attached to the camcorder, remove it before attaching the battery. Also, install the lithium clock cell before attaching the battery pack.

Details on page 48.

1. Hook the top end of the battery to the back of the camcorder *as shown above*.
2. Press the bottom of the battery down until it locks into place.

3. Place the *POWER* switch in *CAMERA*. The power indicator will light.

Remove the Battery

Press and hold *BATT. RELEASE* on the camcorder while removing the battery.

ATTENTION: The RBRC seal on the battery used in your Thomson Consumer Electronics product indicates that we are participating in a program to collect and recycle Nickel Cadmium batteries throughout the United States. Please call 1-800-8-BATTERY for information or contact your local recycling center.



Powering Your Camcorder

Using the Battery to Power Your Camcorder (Continued)

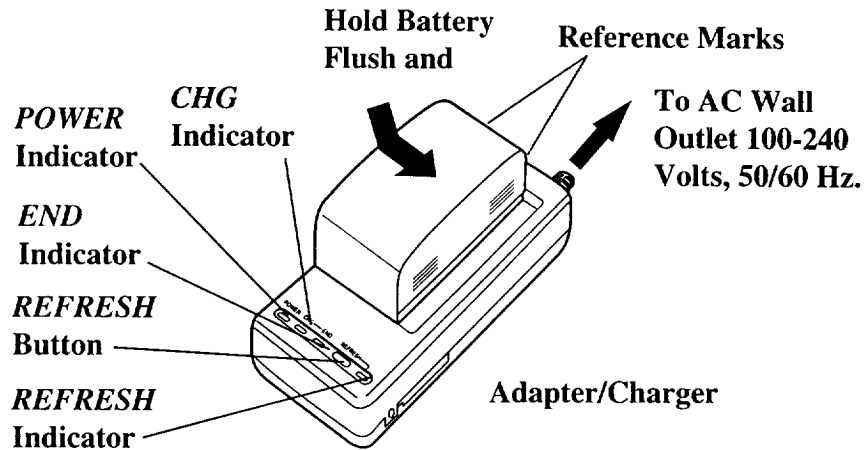

Caution: When a battery is attached to the adapter/charger, do not turn them upside down. The battery may fall off and be damaged or cause injury.

Charge the Battery

If the DC cable is attached to the *DC OUT* jack on the adapter/charger, remove its plug.

1. Align reference mark on battery with mark on adapter/charger.
2. Hold the battery flush against the adapter/charger and slide it in the direction of the arrow.
3. Plug adapter/charger into nearest AC outlet (100-240V, 50/60Hz).
4. If the battery is properly connected, the adapter/charger's *CHG* (charge) indicator will light.

Note: If you try to charge a battery that has not been charged for a long period of time, it may take a few minutes for the *CHG* indicator to light.

5. After the battery is charged, the *END* indicator will light.
6. Remove the charged battery by sliding it off the adapter/charger.
7. Attach the charged battery to the camcorder.

Use the *REFRESH* Button

The battery will provide increased operation time if you "refresh" it after five chargings. The refresh feature "refreshes" the battery by completely discharging it.

1. Attach battery to adapter/charger.
2. Press *REFRESH*. The *REFRESH* indicator will light and the battery will begin discharging.
3. When discharging is completed, the *REFRESH* indicator will turn off, and the *CHG* indicator will light. The battery will then charge.
4. After the battery is charged, the *END* indicator will light. Remove the battery from the adapter/charger.



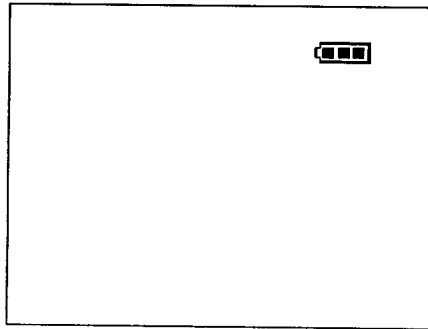

Powering Your Camcorder

Battery Level Indicator

The battery level indicator appears on the LCD monitor or in the viewfinder and shows you the amount of power in the rechargeable battery.



Battery Level Indicator
on LCD Monitor or in
Viewfinder

- When  appears, the battery is fully charged.
- As the power is used  and  appear.
- When the battery power is almost gone,  flashes. The camcorder will turn off automatically after a few seconds. Place the *POWER* switch in *OFF* to turn off the camcorder before replacing the battery.

The battery level indicator will not be recorded on the tape when it appears.

Battery Care and Storage

- Recharging takes approximately 100 minutes depending on the battery's condition.
- Refreshing takes approximately five hours and 30 minutes depending on the battery's condition.
- After repeated charging and use, operation time will gradually decrease. When operation time becomes too short to be useful, it is time to replace the battery.
- If the battery discharging must be stopped in the middle, remove the battery from the adapter/charger before unplugging it from the AC outlet.
- Let a hot battery cool down before attaching it to the adapter/charger.
- The battery will provide better service if its power is completely drained before storing it for long periods of time (30 days or more).
- The battery should be charged in the temperature range of 50-95°F (10-35°C) to prevent damage.
- Do not operate the battery at temperatures below 32°F (0°C) or above 104°F (40°C). The battery may be damaged if operated at temperatures above 122°F (50°C). Operation time will decrease at extremely low temperatures.
- Store the battery at normal room temperature.

Powering Your Camcorder

Optional Car Cord Adapter

The optional DCC08 car cord *shown on page 76* allows you to power your camcorder from the cigarette lighter socket of a car, truck, or RV. It converts 12-volts to a 6-volt output.

Note: Consult the installation and operating instructions enclosed with the DCC08 for complete operating instructions.

Cautions: The DCC08 is designed to be used only with vehicles having negative ground electrical systems.

Use only car cord adapter DCC08 with this camcorder. Use of any other car cord adapter may damage the camcorder and void your warranty.

Using the DCC08 Car Cord Adapter

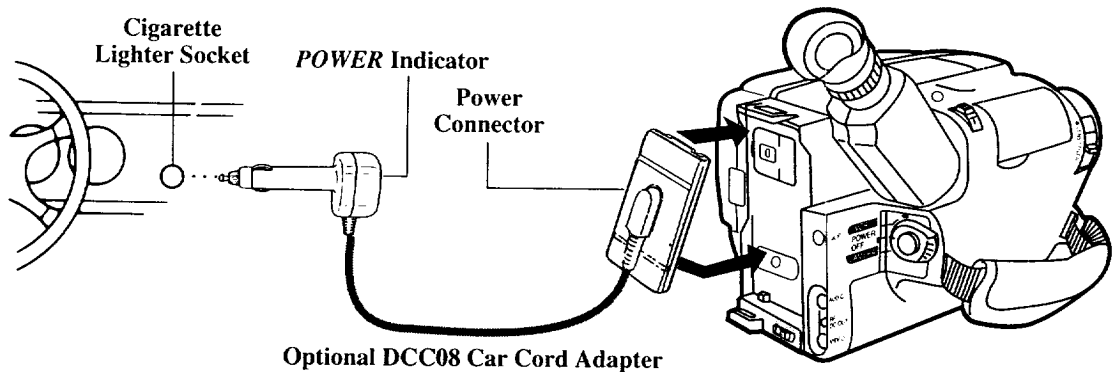

1. Place the *POWER* switch in *OFF* to turn off the camcorder. Power indicator on the camcorder turns off.
2. If the battery or DC cable is attached to the camcorder, remove it.
3. Hold the top of the power connector flush against the camcorder and press the bottom of the power connector down until it locks into place.
4. Take the vehicle's cigarette lighter out of the socket.
5. Insert the car cord's cigarette lighter plug into the vehicle's cigarette lighter socket. The *POWER* indicator on the car cord adapter will light.
6. Place the *POWER* switch in *CAMERA* to turn on the camcorder. The power indicator on the camcorder lights.

Caution: Make sure the camcorder's power is turned off before removing the car cord's plug from the cigarette lighter socket.

Recording Tips

- In case of fire or theft, make a video recording of your home and contents to store in a safe place.
- Try to make sure indoor scenes are well-lit. This improves picture quality and color reproduction.
- Do not move the camcorder rapidly from side-to-side while recording. A steady, gradual “pan” avoids blurring and “jitter”.
- Use the viewfinder or LCD monitor to make sure the camcorder is level while recording or your scenes will appear “tilted”.
- Use the LCD monitor to shoot a scene from a high or low angle, such as over a crowd.
- Do not bump or tap the camcorder’s microphone while recording because this sound will be recorded.
- Include close-ups of individuals when taping family outings or group functions.
- Fading in and out of scenes will make your videos appear more professional.
- Learn to use the special effects available with your camcorder to add variety to your recordings.
- Be aware of video and audio backgrounds. Background details barely noticed while you are taping may show up as visual “clutter” on your recording. Background noises (especially TV sets, radios, household appliances, traffic sounds, etc.) can detract from the sound you want to record.
- Avoid long “still” shots of landmarks and scenic attractions. Recordings are more interesting if they include people and details. “Local color” will give travel videos lasting appeal. Consider recording a familiar or landmark scene from an unfamiliar vantage point.

Video Cassettes

We recommend that our cassettes be used with your camcorder. Use of poor quality tapes or tapes that have been damaged or mishandled can contaminate the video heads, resulting in a snowy picture or no picture at all during playback. Because there is no control over the type of tape purchased or rented by consumers, head cleaning is not covered under warranty. It is considered normal maintenance.

The automatic head-cleaning system minimizes the need for accessory cleaners or cleaning by a Servicer. This system is activated whenever you insert or remove a cassette.

Erase Protection – Safety Tab

You can use your video cassettes over and over again. To erase a previous recording, just record over it.

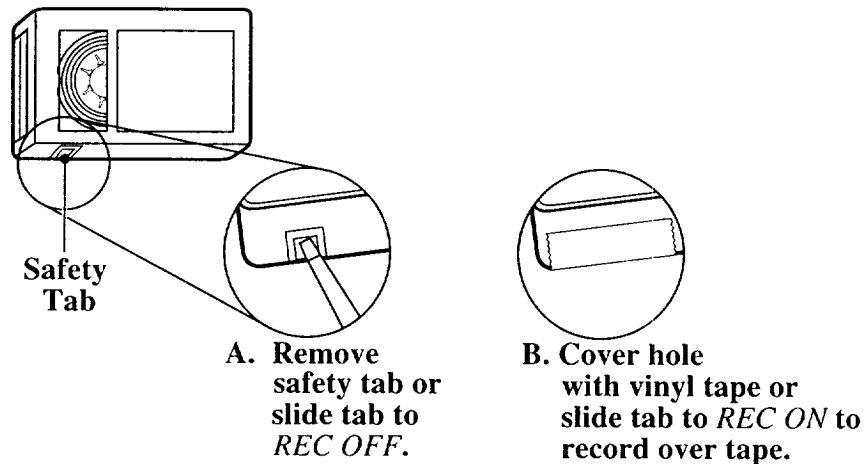

Recording and Playback Speeds and Times

The camcorder records and plays back in standard speed (SP) or extended play (EP). Select the recording speed using the *SP•EP* switch. The selected speed will be displayed on the LCD monitor or in the viewfinder. Listed below are the maximum SP and EP recording times for popular VHS-C cassettes.

- SP – Standard play provides the best picture (less picture noise), but the shortest recording time (20 minutes with a TC-20 tape).
- EP – Extended play provides three times the recording time as SP (60 minutes with a TC-20 tape). EP has slightly more picture noise than SP in normal playback. This may not be noticeable.

Cassette	Recording Time	
	SP	EP
TC-20	20 Min.	60 Min.
TC-30	30 Min.	90 Min.
TC-40	40 Min.	120 Min.

Video Cassettes

Inserting and Removing Cassettes

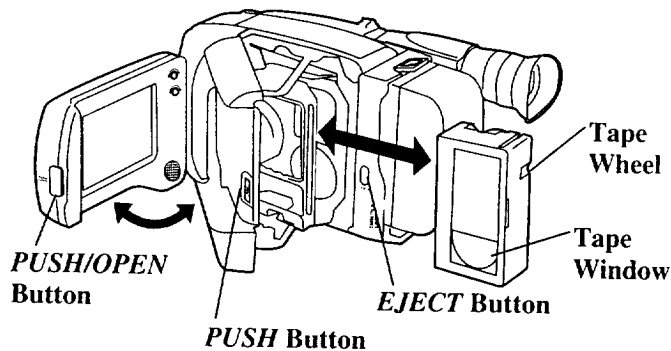

Cautions:

Open monitor at least 60° before opening cassette compartment.

Insert the cassette only one way with the tape wheel facing up and the tape window facing out. The cassette should slide easily into the compartment. Do not force the cassette.

Before inserting a cassette, turn the tape wheel on the side of the cassette in the direction shown to remove any slack in the tape.

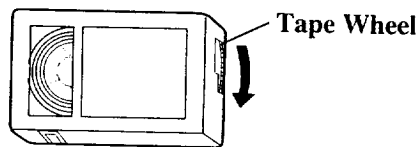

1. Press *PUSH/OPEN* to open the LCD monitor. Open the monitor at least 60° before opening the cassette compartment.

2. Press *EJECT* to open the cassette compartment.

- Turn the tape wheel on the cassette to remove any slack from the tape.
- Insert the cassette with the tape wheel facing up and the tape window facing out.

3. Press the *PUSH* button to lock the cassette door into place.

4. If you are not going to use the LCD monitor to view what you are recording or playing back, close and lock the monitor.

Cassette Care and Storage

- When you are finished with a cassette, rewind it, remove it from the camcorder, and label it.
- Store cassettes vertically in their protective cases at normal room temperatures. Do not leave your camcorder or cassettes in a car or outdoors for an extended period. Excessive heat or cold may damage your cassettes.
- Keep the cassette away from strong magnetic fields such as electric motors and other devices.
- Keep dust from entering the cassette compartment. All dust is abrasive and will cause excessive wear on the tape and the camcorder's recording or playback heads.
- Do not use cassettes with damaged or spliced tape.
- Do not use a cassette if it has been damaged or exposed to moisture. The tape may jam and/or damage your camcorder.

Recording

Making a Recording

The steps below tell you how to make a recording using some of the recording features. Each feature is described in detail on the following pages.

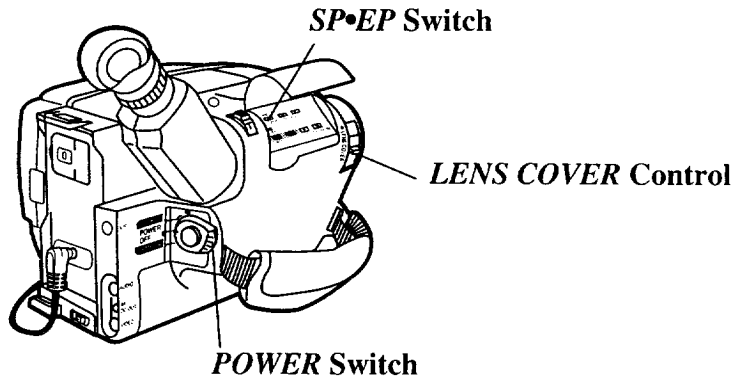

Caution: Open monitor at least 60° before opening cassette compartment.

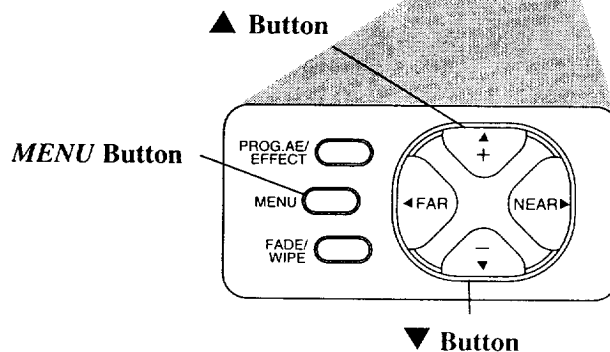
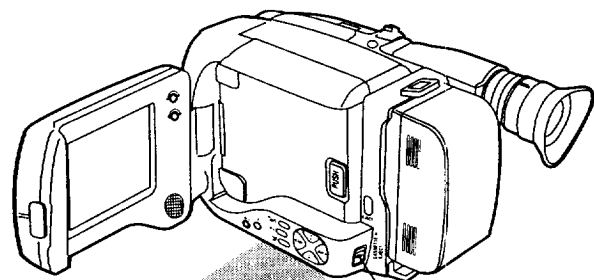
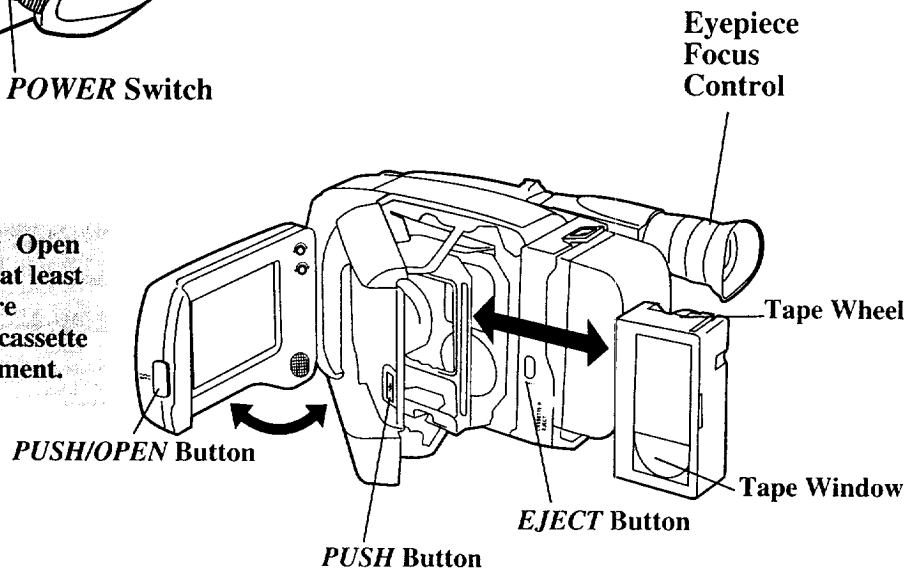

Recording

1. Attach a power supply.

Attach the adapter/charger, charged battery, or optional DC car cord.

2. Insert a tape.

- Press *PUSH/OPEN* to open the LCD monitor. Open the monitor at least 60° before opening the cassette compartment.
- Press *EJECT* to open the cassette compartment.
- Turn the tape wheel on the cassette to remove any slack from the tape.
- Insert the cassette with the tape wheel facing up and the tape window facing out.
- Press the *PUSH* button on the side of the cassette compartment to lock the cassette holder into place.

3. Slide the *LENS COVER* control to open the lens cover.

4. Place the *POWER* switch in *CAMERA*.

The power indicator will light and the camcorder will enter record pause.

≡ PAUSE ≡ appears in the viewfinder or on the LCD monitor.

5. Use the LCD monitor or viewfinder to view what you are recording.

Use the LCD Monitor

- Make sure the monitor is open at least 60°. The viewfinder will be automatically turned off.
- Tilt the LCD monitor (up to 45° up or down).
- Adjust the brightness of the image by turning the *BRIGHT* dial.

Use the Viewfinder

- Make sure the monitor is closed and locked. The viewfinder will be automatically turned on.
- Adjust the viewfinder for a comfortable viewing position.
- Turn the eyepiece focus control to adjust the focus of the viewfinder for your vision.

6. Select a recording speed and tape length.

A. Place the *SP•EP* switch in SP or EP to select a recording speed.

B. Make sure the *FULL AUTO/ PRESET* switch is in *PRESET*.

C. Press the *MENU* button and use the ▲ or ▼ button to highlight *TAPE LENGTH*. Use ◀ and ▶ to select the length of the tape you are using (*T20*, *T30*, or *T40*) so the camcorder can correctly calculate the time remaining. Press the *MENU* button again to remove the menu.

(continued on next page)

Recording

Making a Recording (Continued)

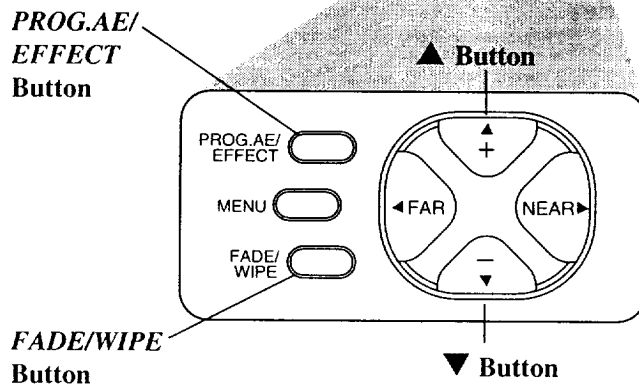
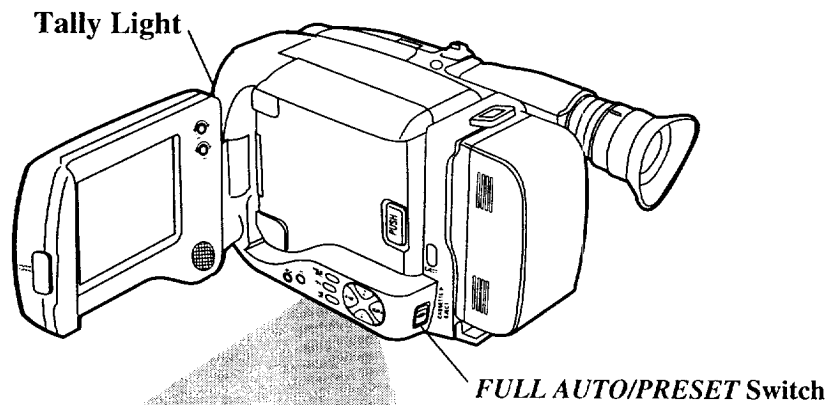
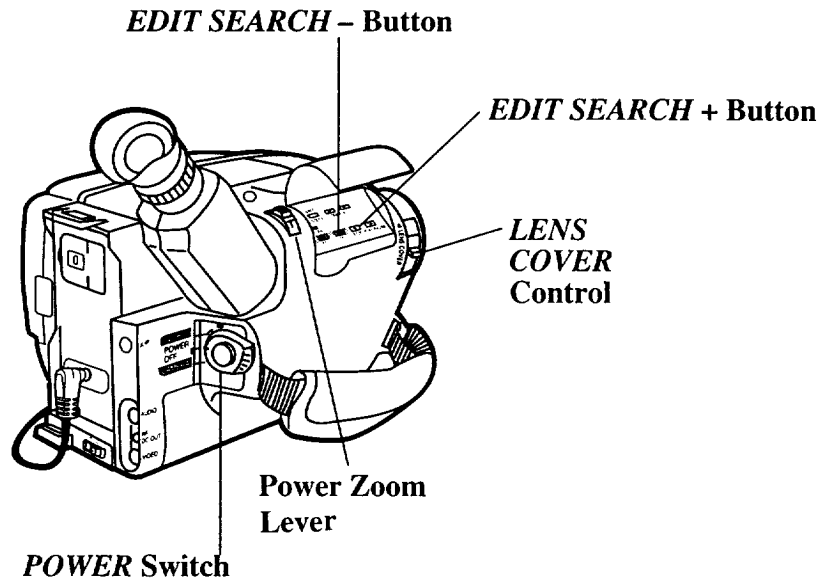

Recording

7. Select a production special effect to add variety to your recordings.



- A. Make sure the *FULL AUTO/ PRESET* switch is in *PRESET*.
- B. Press *PROG.AE/EFFECT* to display the production effects menu in the viewfinder or on the LCD monitor.
- C. Press *PROG.AE/EFFECT* again to select the effect you want. The effect is selected automatically and its indicator appears in the viewfinder or on the LCD monitor.
 - Select *Cinema* (16X9 effect), *Sepia* (brown-tone effect), *Twilight* (dusk and twilight scenes), *Sports* (fast moving action), or *H.I.S* (hi-speed shutter for even faster moving action).
 - The effect is automatically activated, and its indicator appears.
 - *Details are on pages 62-63.*

8. Add fades and wipes.

- A. Make sure the *FULL AUTO/ PRESET* switch is in *PRESET*.
- B. Press the *FADE/WIPE* button to display the fade menu in the viewfinder or on the LCD monitor.
- C. Repeatedly press the *FADE/WIPE* button to select a fade or wipe.
 - Select *Black Fader*, *Blue Fader*, *Mosaic Fader*, *Shutter Wipe*, or *Slide Wipe*.

- The effect is automatically activated, and its indicator appears.
- *Details are on pages 60-61.*

9. Start and stop recording.

- Press and release the thumb trigger to start recording.  appears in the viewfinder or on the LCD monitor and the tally light lights when the camcorder is recording.
- Press and release the the thumb trigger again to stop recording. The camcorder is now in record pause.  appears.
- The camcorder will automatically turn off if it remains in record pause for five minutes. Place the *POWER* switch in *OFF* and then back in *CAMERA*.

10. Zoom in and out.

- Zoom in and out using the zoom *T* and *W* lever.

11. Review what you have recorded.

- Press and quickly release *EDIT SEARCH* – to review the last few seconds of your recording.
- Press and hold *EDIT SEARCH* – or + to visually see what you have recorded. Release the button to begin recording at that point.

12. When you are finished, place *POWER* switch in *OFF*, close and lock the LCD monitor, and close the lens cover.

Recording

Viewing What You Are Recording Using the LCD Monitor or Viewfinder

You can watch what you are recording on the color LCD monitor or in the black-and-white viewfinder. When the LCD monitor is open more than 60° in *CAMERA*, the viewfinder is automatically turned off. When you close the LCD monitor, the viewfinder is automatically turned on.

Use the LCD Monitor

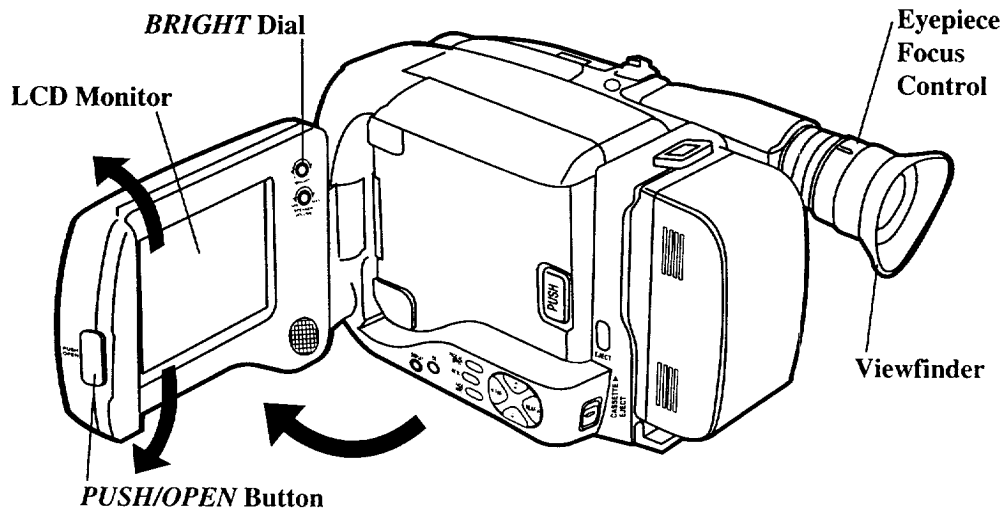

1. Press the *PUSH/OPEN* button and open the LCD monitor.

Make sure the monitor is open at least 60°. The viewfinder will be automatically turned off.

2. You can tilt the monitor up or down 45° for convenient viewing.
 - Tilt the monitor down to record from a high angle, such as over a crowd.
 - Tilt the monitor up to record from a low angle, such as when you are kneeling.

3. Adjust the brightness of the image by turning the *BRIGHT* dial. This does not effect the brightness of the recording you are making.

- Turn the dial toward “+” to brighten the image.
- Turn the dial toward “-” to darken the image.

4. When you are finished, close the monitor and lock it into place.

Note: When recording on a bright sunny day, the LCD monitor may be hard to see. Use the viewfinder.

Recording

Use the Viewfinder

The camcorder's viewfinder is a miniature monitor that displays the picture seen by the camcorder when recording. When the LCD monitor is open more than 60°, the viewfinder is automatically turned off.

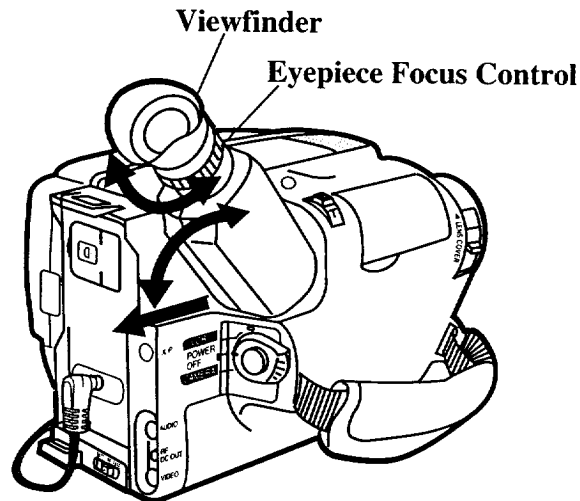

Adjust Viewfinder for Convenient Viewing

For convenient viewing, you can slide the viewfinder out from the camcorder and rotate it up and down.

Eyepiece Focus Control

The eyepiece focus control lets you set the focus of the viewfinder for your personal vision. If you wear eyeglasses,

you probably can operate the camcorder without them.

It is easiest to set the correct focus by focusing on one of the viewfinder's on-screen displays.

Look through the viewfinder and adjust the eyepiece focus control for your vision.

The eyepiece focus control does not affect the focus of the picture actually recorded by the camcorder.

Cautions

Do not force the LCD monitor or viewfinder to rotate completely around. This will damage the monitor, viewfinder, and/or the camcorder.

When carrying the camcorder with the shoulder strap, close and lock the LCD monitor and put the viewfinder down and slide it in. This helps prevent possible damage to the monitor or viewfinder from bumping against your body as you move.

Recording

LCD Monitor or Viewfinder Displays

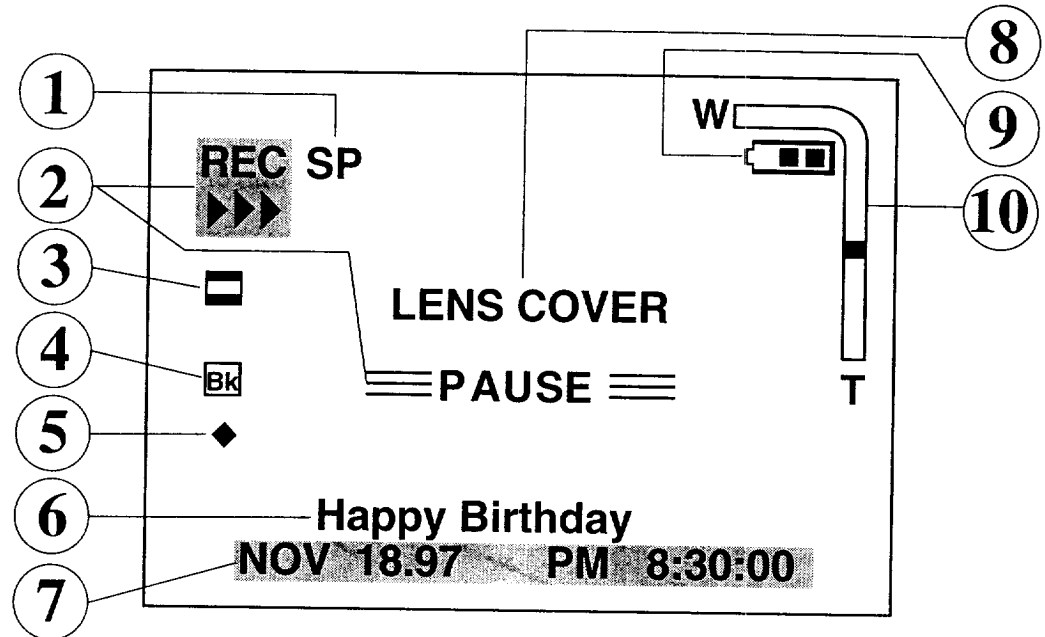



1 Tape Speed Indicators (*SP* or *EP*)

The tape speed selected with the *SP*•*EP* button appears here.

• *Details on page 18.*





2 Status Displays

• The  indicator appears when the camcorder is recording.

• The  PAUSE  indicator appears during record pause.





3 Production Effects Indicators

The indicator for the production effect selected with the *PROG.AE/EFFECT* button appears here. When the *FULL AUTO/PRESET* switch is in *FULL AUTO*, *Cinema* is automatically selected. Place the switch in *PRESET* to select the other effects.

-  appears when you select *Cinema* to “letterbox” record with black bars so you can play back your recordings on a 16X9 TV.
-  appears when you select *Sepia* to give your recordings a brown-tone like old photographs.
-  appears when you select *Twilight* to record scenes at dusk and twilight.
-  appears when you select *Sports* to record fast moving action, such as sporting events.
-  appears when you select *HIS 1/2000* to record even faster moving action than *Sports*.
- *Details are on pages 62-63.*

④ Fade and Wipe Indicators

The indicator for the fade or wipe scene transition selected with the *FADE/WIPE* button appears here. When the *FULL AUTO/PRESET* switch is in *FULL AUTO*, *Black Fader* is automatically selected. Place the switch in *PRESET* to select the other fades or wipes.

-  appears when you select *Black Fade* and a black screen fades in and out.
 -  appears when you select *Blue Fade* and a blue screen fades in and out.
 -  appears when you select *Mosaic Fade* and the picture turns into a mosaic pattern as you fade in and out.
 -  appears when you select *Shutter Wipe* and a black screen wipes in from top and bottom or the image pushes open the black screen from the center to the top and bottom.
 -  appears when you select *Slide Wipe* and a black screen wipes in from the left or the image moves in from right to left..
- *Details are on pages 60-61.*

⑤ Change Indicator (◆)

This indicator will appear to let you know that an item in the recording menu has been changed from the original factory setting.

⑥ Title

The preset title you select or the title you create will appear in this area.

- The title will be recorded on your tape when it appears.
- *Details are on pages 45-47.*

⑦ Date or Date and Time

The date, time, or date and time appears in this area when you press the *DISPLAY* button.

- These displays will be recorded on your tape when they appear.
- *Details are on pages 49-51.*

⑧ LENS COVER Indicator

- *LENS COVER*: When you turn on the camcorder, this indicator briefly flashes to remind you to open the lens cover.
- *LENS COVER*: This indicator may flash when the camcorder is used in dark areas — even if the lens cover is open.

⑨ Battery Level Indicator

- This indicator shows power left in the rechargeable battery.
- This indicator flashes when the battery is almost empty.
- *Details are on page 15.*

⑩ Zoom Indicator

The zoom indicator appears here when you use the zoom lever.

- *Details on page 39.*

(continued on next page)

LCD Monitor or Viewfinder Displays

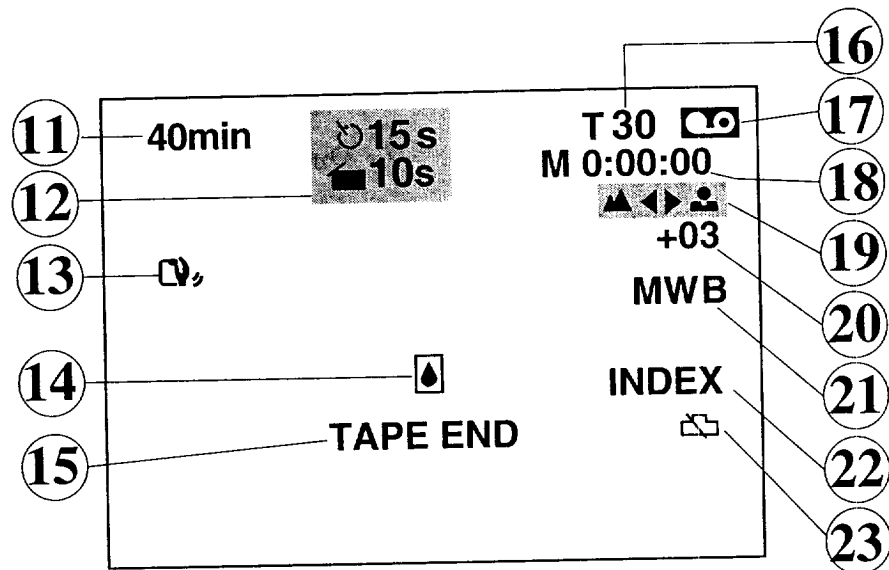

11 Time Remaining Display

The approximate time remaining on the tape is automatically displayed here. The correct *Tape Length* must be set in the recording menu. *Details are on page 44.*

12 Self-Timer, Animation, and Time-Lapse Indicators

- The interval time selected for self-timer or time-lapse recording (☉ 15S, 30S, 1min, or 5min) appears here. *Details are on pages 54-55 and 58-59.*
- The rec time selected for animation or time-lapse recording (◀ 1/4S, 1/2S, 1S, or 5S) appears here. *Details are on pages 56-57 and 58-59.*

13 Electronic Image Stabilizer (EIS)

This indicator appears when the electronic image stabilizer is turned on with the *EIS* button. *• See page 38 for details.*

14 Dew Warning (Dew)

The dew indicator appears when excessive moisture (condensation) has entered the camcorder. The camcorder will not operate when this indicator appears. Place the camcorder in a warm, dry area until this indicator disappears.



15 **TAPE END Warning**

- **TAPE END** appears when the end of the tape is reached during recording or a cassette is inserted with its tape already at the end.

16 **Tape Length**

The tape length (*T20*, *T30*, or *T40*) selected with the *Tape Length* feature on the recording menu appears here. *Details are on page 44.*

17 **Cassette Warning**



- The  indicator appears when a cassette is in the camcorder.
- The  indicator flashes when the **POWER** switch is set to **CAMERA** and there is no cassette in the camcorder.

18 **Time-Counter**

- The time counter appears during playback. It is not recorded.
- An “*M*” appears in front of the time counter when memory-stop is on.
- *Details are on page 70.*

19 **Manual Focus Indicators** ()



These indicators appear when focus is adjusted manually using the **NEAR** or **FAR** button. The **FULL AUTO/PRESET** switch must be in **PRESET**.

- Manual focus lock indicators () appear when focus is moving toward near or far.
- Low-contrast indicators () flash when the auto-focus system cannot focus properly.
- *Details are on pages 36-37.*

20 **Exposure Indicator**

- This indicator appears when you are adjusting brightness manually using the + or – button. The **FULL AUTO/PRESET** switch must be in **PRESET**.
- *Details are on page 33.*

21 **White Balance Indicators**

- If you adjust white balance manually, the indicator (*MWB*, , , or ) for the mode you select appears here. The **FULL AUTO/PRESET** switch must be in **PRESET**.
- *Details are on pages 34-35.*

22 **INDEX Indicator**

- **INDEX** appears when an index mark is being made on the tape. *Details are on page 32.*

23 **Lithium Cell** ()

- This indicator flashes for a few seconds when you first turn on the camcorder and the time and date have not been set.
- This indicator also appears when the clock cell is missing or it needs to be replaced. *Details are on page 48.*

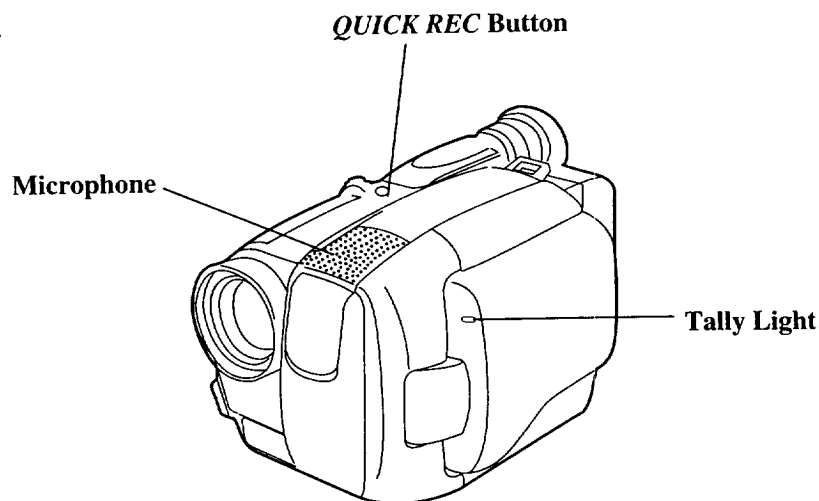

Microphone

The microphone picks up the sound during a recording. It is more sensitive to sounds coming from the direction the lens is pointed.

Flying Erase Head

A separate erase head is mounted on the spinning headwheel (hence the term “flying”). This allows you to make clean edits without the “glitches” or “rainbow noise” that may occur at the beginning or the end of recordings.

Auto Head Cleaner

The camcorder has an automatic head-cleaning system. Whenever a cassette is inserted or removed, this system is activated.

The head-cleaning system minimizes the need for accessory cleaners or cleaning by a Servicenter.

Tally Light

The tally light lights when the camcorder is recording.

The tally light can be turned off using the record menu. *See page 53.*

Quick Record

Quick record lets you make five second recordings for quick scene transitions. Place *VCR/OFF/CAMERA* switch in *CAMERA*.

- Press and release *QUICK REC* to make a five-second recording. The camcorder will record for five seconds and return to record pause.
- Press and hold *QUICK REC* to continue recording. Release the button to return the camcorder to record pause. Press the thumb trigger to start normal recording at this point.

Notes: Fading does not operate when you use the *QUICK REC* button to record.

Quick recording cannot be used during animation or time-lapse recording.

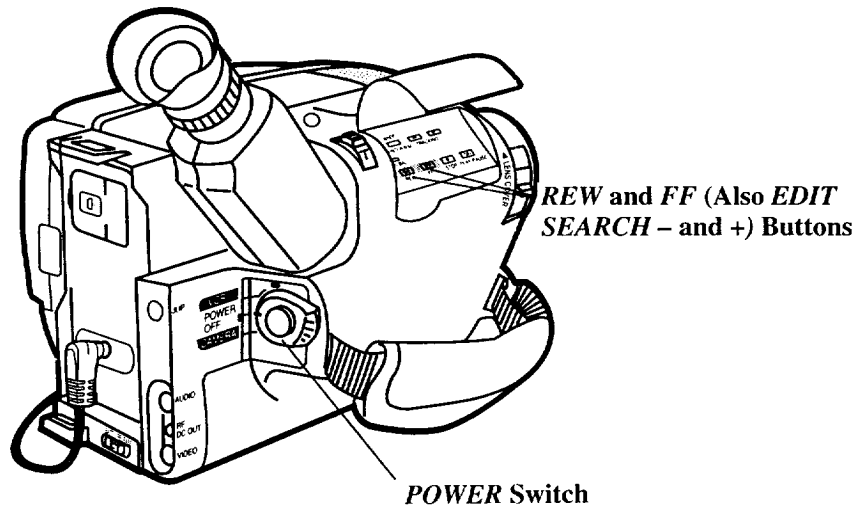

Tape Positioning

Place *POWER* switch in *VCR* and press *STOP*.

- Press and quickly release *REW* or *FF* to rewind or fast-forward the tape. Press *STOP* to stop the tape.

Quick Review Feature

Press and release *EDIT SEARCH -* when the camcorder is in record pause to review the last few seconds of a recording. The *POWER* switch must be in *CAMERA*.

The camcorder will play back the last few seconds of the recording, return the tape to its previous position, and return to record pause.

Camera Edit Feature

The camera edit feature allows you to position the tape when the camcorder is in record pause. Place *VCR/OFF/CAMERA* switch in *CAMERA*.

- Press and hold *EDIT SEARCH -* to visually search the recorded tape in reverse.
- Press and hold *EDIT SEARCH +* to visually search forward on the recorded tape.

Release the button to return camcorder to record pause at that point on the tape. Press the thumb trigger to start recording at this point.

Recording

Full Auto Mode

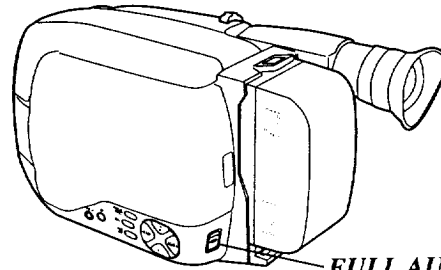

1. Place the *POWER* switch in *CAMERA*.
 - The power indicator will light and the camcorder will enter record pause. ≡ PAUSE ≡ appears in the viewfinder or on the LCD monitor.
2. Place the *FULL AUTO/PRESET* switch in *FULL AUTO*.
3. Press the thumb trigger to start recording.
 - The camcorder will control the focus, exposure, and white balance for you.
4. Place the *FULL AUTO/PRESET* switch in *PRESET* to turn off the full auto mode.
 - The only fade/wipe that you can use is the black fader.
 - The only production special effects you can use is cinema.
 - Menu changes cannot be made.

Electronic Indexing

An index mark is automatically recorded at the beginning of a recording after the date advances and a cassette is inserted. When you play back the indexed tape in a VCR that has a compatible indexing feature called "VHS Index Search System", the invisible marks can be located automatically. See VCR owner's manual.

INDEX flashes in the viewfinder or on the LCD monitor when an index mark is recorded.

Notes: No other function can be performed during index recording.

If the date changes during recording, an index mark is placed on the tape.

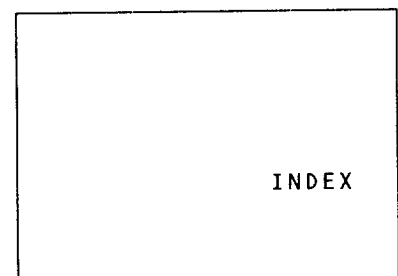

***INDEX* Indicator on LCD Monitor or Viewfinder**

Recording

Exposure Control

When the *FULL AUTO/PRESET* switch is in *FULL AUTO*, the camcorder controls the iris for you. Under normal conditions, the camcorder will adjust brightness automatically. You may need to adjust brightness manually when the background is too bright or too dark in comparison with the subject.

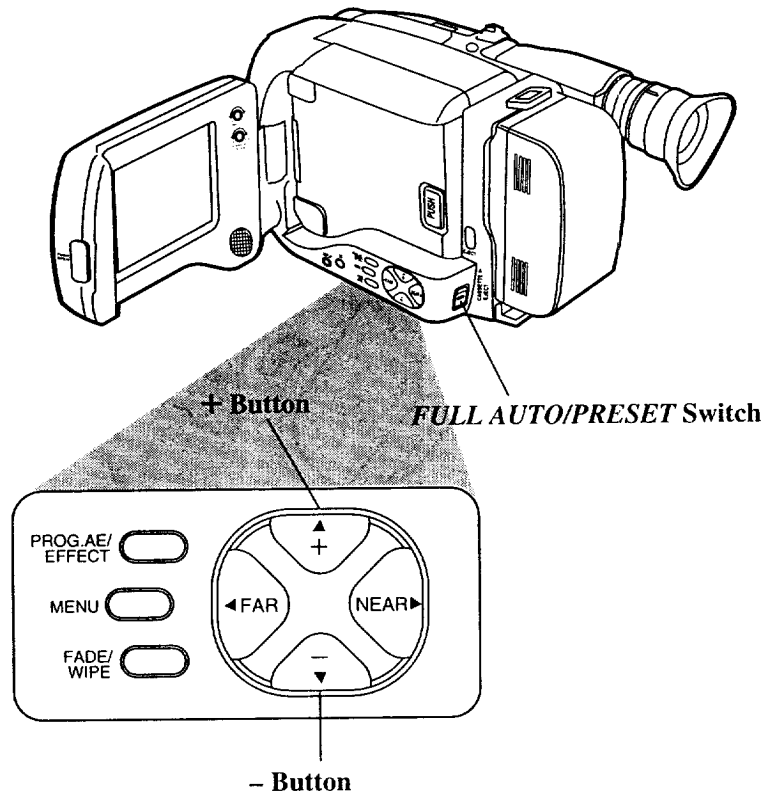

Manual Exposure

1. Place the *POWER* switch in *CAMERA*.
 - The power indicator will light and the camcorder will enter record pause. \equiv PAUSE \equiv appears in the viewfinder or on the LCD monitor.
2. Place the *FULL AUTO/PRESET* switch in *PRESET*.
 - Press + to brighten the image.
 - Press - to darken the image.
 - The exposure level indicator (± 01 to 06) appears in the viewfinder.

To Turn Off Manual Exposure

Press both + and - at the same time or place the *FULL AUTO/PRESET* switch in *FULL AUTO*.

Conditions Requiring Manual Exposure

- When recording with a bright background or reverse lighting.
- When recording with a very dark background or very bright subject.
- When recording a reflective natural background — such as a beach or when skiing.

White Balance

Making colors look natural is what white balance is all about. This is achieved by adjusting the way the camcorder “sees” and records the light source in the scene you wish to record. Your camcorder is equipped with automatic white balance. However, under certain conditions, such as recording an object with various shades of the same color or when recording a predominant red or brown object outdoors, you may want to adjust white balance manually.

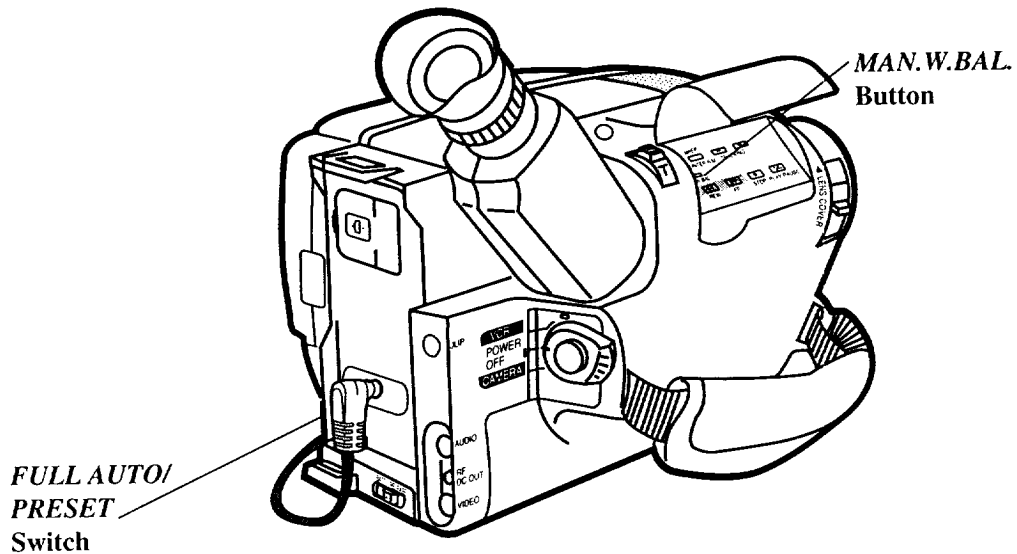

Auto White Balance

During auto white balance, the camcorder will automatically adjust the white balance.

1. Place the *POWER* switch in *CAMERA*.
2. Place the *FULL AUTO/PRESET* switch in *FULL AUTO*.

Manual White Balance

1. Place the *POWER* switch in *CAMERA*.
2. Place the *FULL AUTO/PRESET* switch in *PRESET*.

3. Press the *MAN.W.BAL.* (manual white balance) button until one of the manual white balance indicators appears in the viewfinder or on the LCD monitor.

- Select *MWB* when shooting subjects with different color temperatures and adjust the white balance as follows:

Note: Connecting your camcorder to a color TV monitor may be helpful when making white balance adjustments.

(continued on next page)

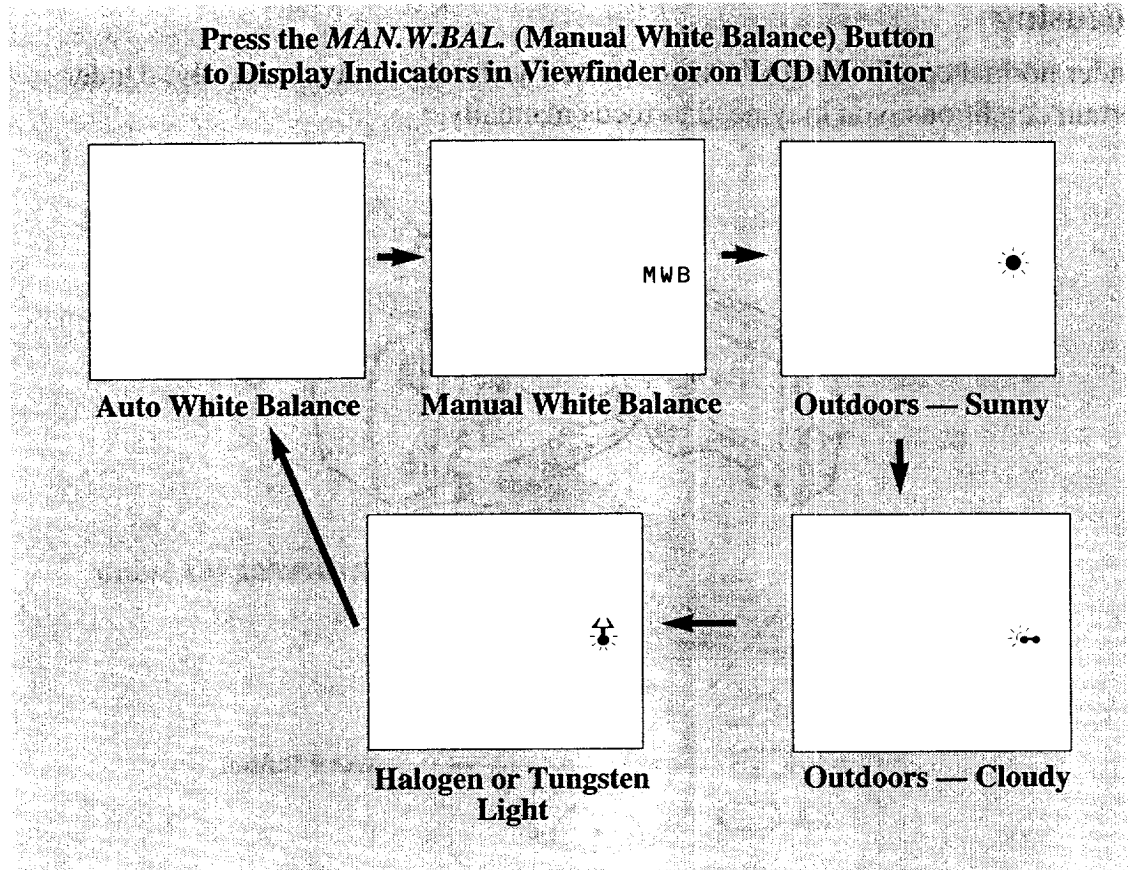

- A. Point camcorder at a white, flat object such as a piece of white paper.
- B. Press and hold *MAN.W.BAL.* for at least three seconds.

The *MWB* indicator will flash while the camcorder is adjusting white balance and stop flashing when it is ready to record.

Note: To change the tint for special recording, substitute colored paper for white. The white balance is adjusted based on the color.

Red paper – deeper green
 Blue paper – orange
 Yellow paper – deeper purple

- Select ☀ when recording outdoors on a sunny day.
 - Select ☁ when recording outdoors on a cloudy day.
 - Select 💡 when recording using halogen or tungsten lighting.
4. To have camcorder automatically control white balance, repeatedly press *MAN.W.BAL.* until no white balance indicator appears in the viewfinder or on the LCD monitor (or place the *FULL AUTO/PRESET* switch in *PRESET*).

Note: Manual white balance does not operate if *Sepia* is selected as a program effect.

Recording

Focusing

Under normal conditions, the camcorder can adjust focus automatically. Under certain conditions, you may need to focus manually.

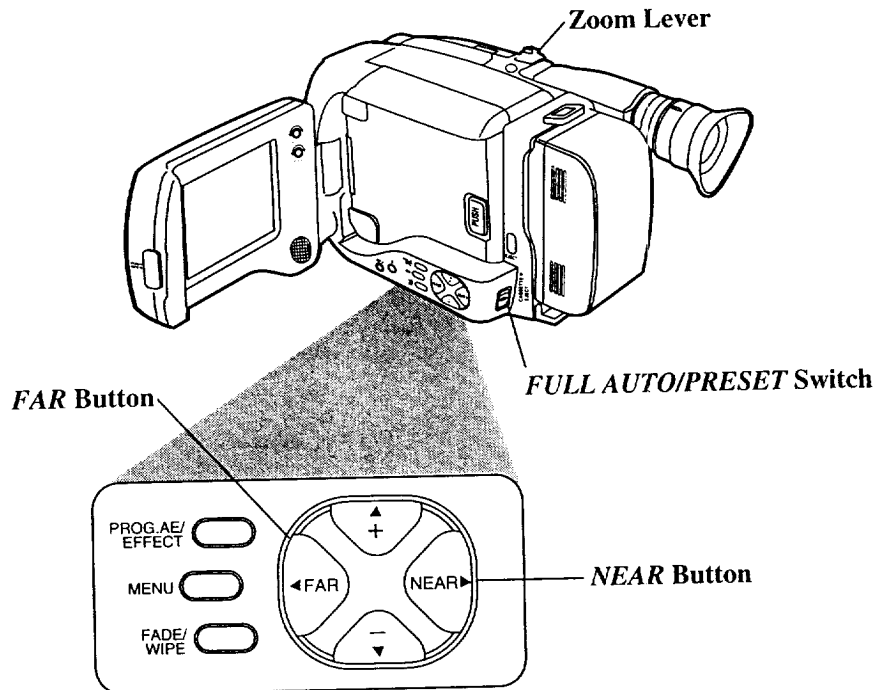

Auto Focus

During auto focus the camcorder will focus automatically on the object located in the center area of the viewfinder or LCD monitor.

- Place the *FULL AUTO/PRESET* switch in *FULL AUTO* to turn on the auto focus feature.

Notes: The low-contrast indicator (\blacktriangle \blacktriangleright) in the viewfinder indicates the auto-focus system may not operate correctly due to low illumination, low or no contrast, repeated patterns, or two subjects at different distances overlapping.

If you zoom in too close to the subject, the camcorder will automatically zoom out so it can focus.

Focus Lock Feature

The focus lock feature is useful when objects pass between your subject and the camcorder or your main subject is not located in the center of the viewfinder or LCD monitor.

1. Place the *FULL AUTO/PRESET* switch in *PRESET*.
2. Center the main object in the viewfinder or LCD monitor.
3. Press *FAR* or *NEAR* to focus on the main subject. The focus is locked on the subject and (\blacktriangle \blacktriangleright) appears on the LCD monitor or in the viewfinder.
4. Press *FAR* and *NEAR* together (or place *FULL AUTO/PRESET* switch in *FULL AUTO*) to turn auto focus back on.

Recording

Manual Focus

Under certain conditions, such as those listed, you may need to focus manually.

1. Set the *FULL AUTO/PRESET* switch to *PRESET*.
2. Slide the power zoom lever toward *T* to zoom in on your subject. To maintain proper focus throughout the zoom range, you must zoom in on the subject before adjusting the focus.
3. Press *NEAR* or *FAR* to display a clear picture in the center of the viewfinder. The ▲ ● indicators appear in the viewfinder. The ◀ or ▶ indicator will flash. When the focus cannot be adjusted any farther, the ▲ indicator will flash. When the focus cannot be adjusted any closer, the ● indicator will flash.
4. Release the *NEAR* or *FAR* button to lock in the manual focus.
5. Press *NEAR* and *FAR* together (or place *FULL AUTO/PRESET* switch in *FULL AUTO*) to turn auto focus back on.

Conditions Requiring Manual Focus

- When recording a subject through a window.
- When recording a subject having a close foreground and a background that is far away.
- When recording two subjects at different distances that overlap in the same scene.
- When the subject is not in the center of the viewfinder.
- When recording in low-light situations.
- When recording a scene with fast motions, like a tennis swing.

Recording

Electronic Image Stabilizer (EIS)

The electronic image stabilizer helps compensate for unstable images caused by camera shake that can be created by recording out of a moving vehicle or while walking.

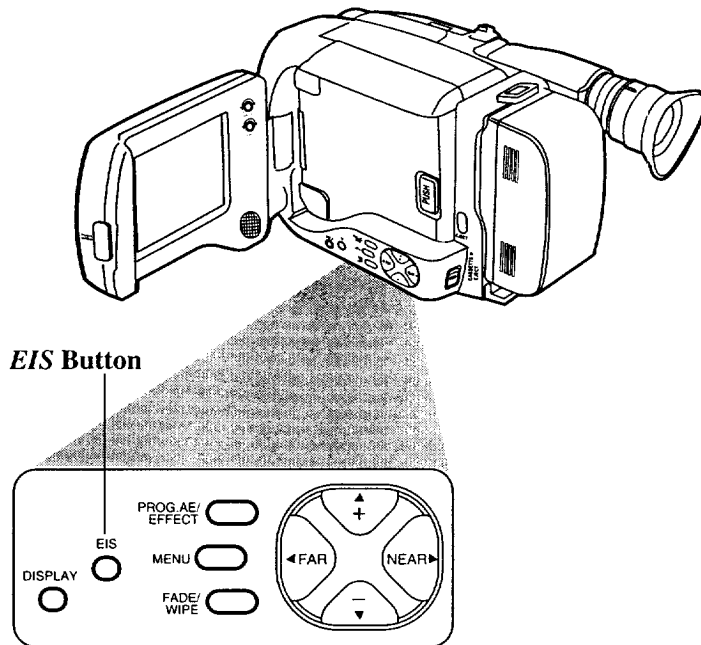

To Turn On EIS

1. Place the *POWER* switch in *CAMERA*.
2. Press the *EIS* button. The EIS indicator appears in the viewfinder or on the LCD monitor.

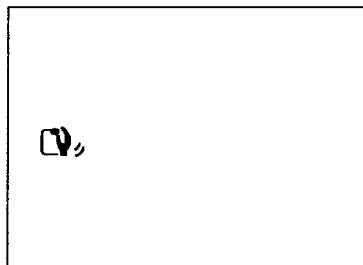

**EIS Indicator in Viewfinder
or on LCD Monitor**

Turn off EIS when using a tripod.

Stabilization may not be possible if hand shake is excessive or when shooting the following:

- Subjects with vertical or horizontal stripes.
- Low contrast subjects or backgrounds or dark or dim subjects.
- Subject with excessive backlighting.
- Scenes with movements in various directions.

To Turn Off EIS

Press the *EIS* button. The EIS indicator disappears from the viewfinder.

Recording

Zooming

The motorized zoom lens allows you to zoom in and out for close ups or wide-angle shots just by sliding the power zoom lever on the camcorder.

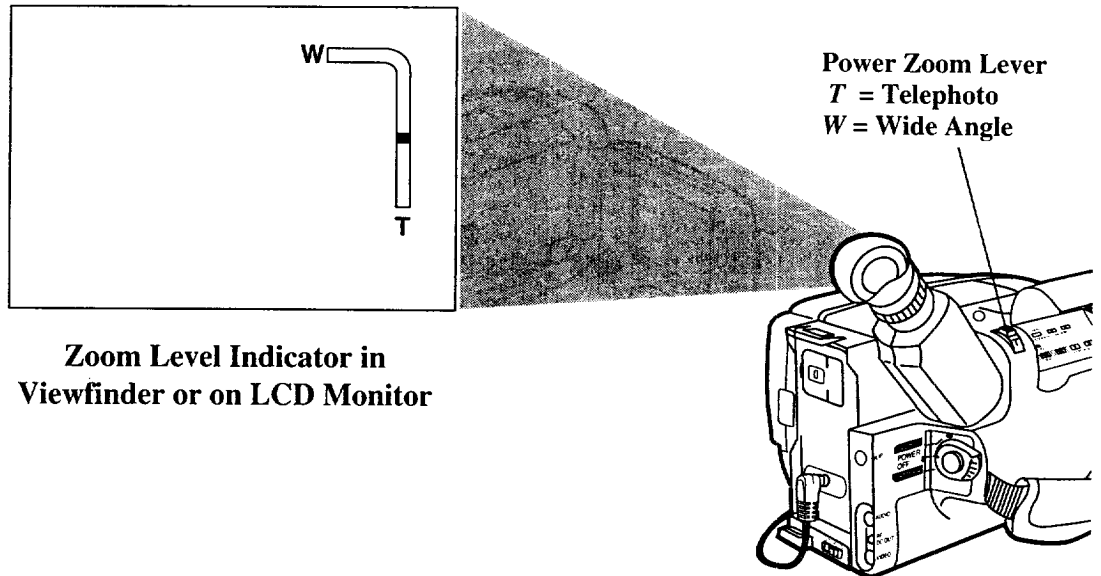

Zoom Level Indicator in Viewfinder or on LCD Monitor

To Zoom In and Out

Optical zooming allows you to zoom in and out up to 14X.

- To move the lens in the telephoto (close-up) direction, slide the power zoom lever toward *T*.
- To move the lens in the wide angle direction, slide the lever toward *W*.
- The zoom level indicator appears in the viewfinder or on the LCD monitor.

Note: If you are trying to zoom in very close to a subject and the camcorder zooms out, try using Tele Macro zooming. See page 41.

Digital Zooming

Digital zooming doubles the maximum 14X normal optical zooming. The zoom indicator does not operate during digital zooming.

Zoom speed varies according to how far you zoom in or out.

Notes: You may need to focus manually during digital zooming. Zoom in, adjust the focus manually or use focus lock, and then zoom in or out.

The quality of the image may not be as good in digital zooming as optical zooming.

Recording

Recording Menu

The main recording menu lets you select and set several recording features: *Tele Macro* (close-up), *Gain Up* (light adjustment), *Color Filter*, *Tape Length*, *Title*, and *Date/Time*. The *Sub Menu* lets you turn the tally light on or off, set interval and recording times for self-timer, animation, and time-lapse recording, and set an ID number.

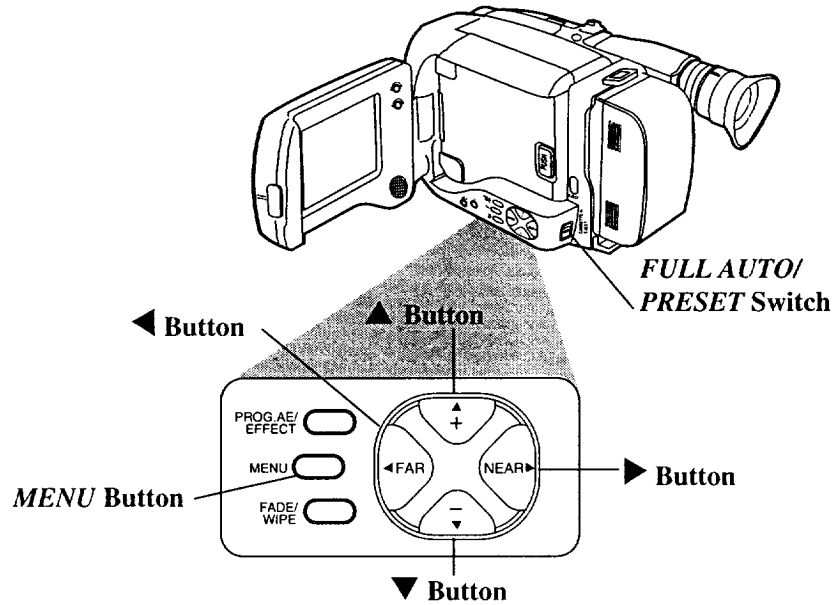

To Display the Recording Menu

1. Make sure the *FULL AUTO/PRESET* switch is in *PRESET*.
2. Press the *MENU* button. The recording menu will appear in the viewfinder or on the LCD monitor.
3. Press **▲** or **▼** to highlight the feature you want to adjust.
4. If you select *Tele Macro*, *Gain Up*, *Color Filter*, or *Tape Length*, press **◀** or **▶** to select the option you want for that feature.

If you select *Date/Time* or *Title*, press **▶** to access the selection menu for the feature.

5. Press *MENU* to exit the menu.

Tele Macro	OFF
Gain Up	AGC
Color Filter	NOR.
Tape Length	T20
Title	
Date/Time	
Sub Menu	

Recording Menu in Viewfinder
or on LCD Monitor

Notes: If you want to change another feature, repeat steps 3 and 4.

If you make a change in the recording menu, **◆** appears in the viewfinder or on the LCD monitor.

3. Press **▲** or **▼** to highlight the feature you want to adjust.

Recording

Recording Menu — *Tele Macro* Zooming Feature

Tele Macro (close-up), zooming allows you to zoom in on subjects that are too close to focus on during normal zooming. If the subject is more than approximately 23 inches away, use normal zooming.

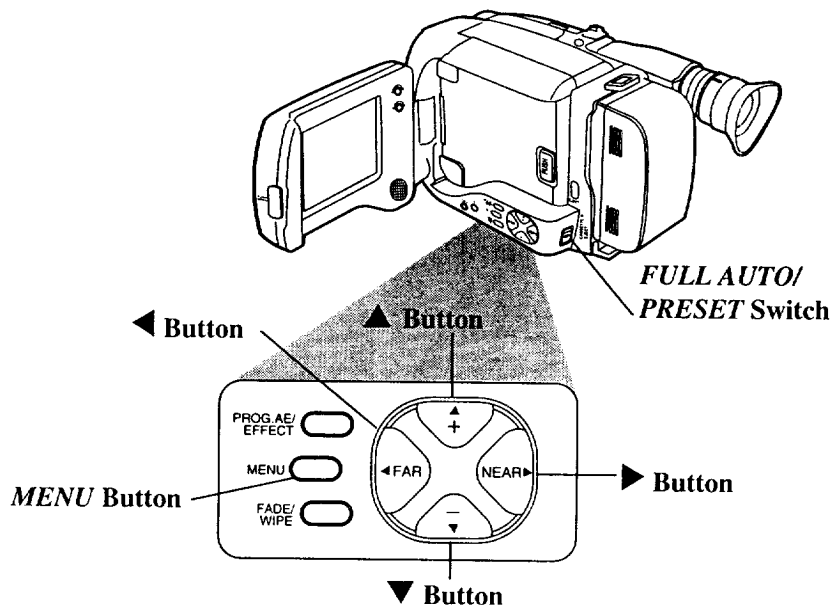

To Turn on Tele Macro

1. Make sure the *FULL AUTO/PRESET* switch is in *PRESET*.
2. Press the *MENU* button. The recording menu will appear in the viewfinder or on the LCD monitor.
3. Make sure *Tele Macro* is highlighted or press ▲ or ▼ to highlight it.
4. Press ► or ◀ to select *OFF* or ◆*ON*.
 - Select ◆*ON* if you want to record a small subject within approximately 23 inches.
 - Select *OFF* for normal zooming.
5. Press *MENU* to exit the menu.

Tele Macro	OFF
Gain Up	AGC
Color Filter	NOR.
Tape Length	T20
Title	
Date/Time	
Sub Menu	

Note: Depending on the position of the zoom, the lens may go out of focus.

Recording

Recording Menu — Tape Time-Remaining Display

The approximate time remaining on the tape in the camcorder is automatically displayed in the viewfinder. The *Tape Length* feature in the recording menu must be set correctly for the length tape you are using before the camcorder can correctly calculate time remaining.

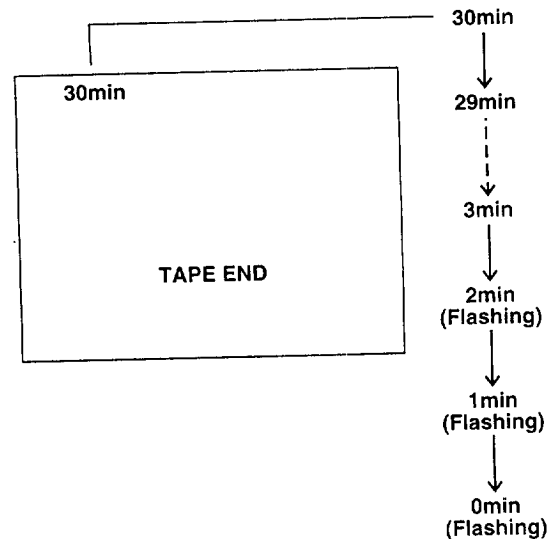
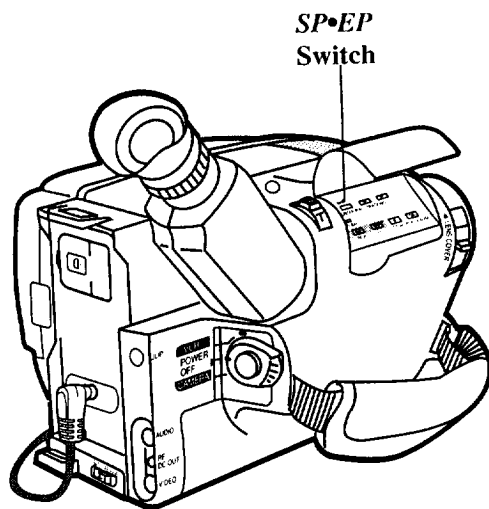

Set the Tape Length

1. Make sure the *FULL AUTO/PRESET* switch is in *PRESET*.
2. Press the *MENU* button. The recording menu will appear in the viewfinder or on the LCD monitor.

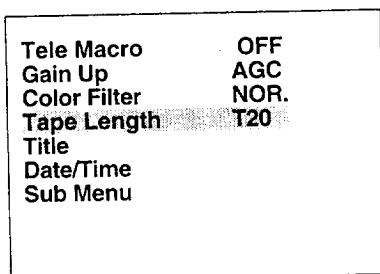

3. Press ▲ or ▼ to highlight *Tape Length*.
4. Press ◀ or ▶ to select the length of tape you are using:

- Select *T20* if you are using a tape with 20 minutes recording time in SP speed.
- Select *T30* if you are using a tape with 30 minutes recording time in SP speed.
- Select *T40* if you are using a tape with 40 minutes recording time in SP speed.

5. Press *MENU* to exit the menu.

Notes: The time-remaining indicator will start flashing when the remaining tape time reaches two minutes.

TAPE END appears when the tape reaches its end during recording or a cassette is loaded with its tape already at the end.

Recording

Recording Menu — Gain Up

The gain up feature allows you to take bright and natural recordings even in areas with low or poor lighting.

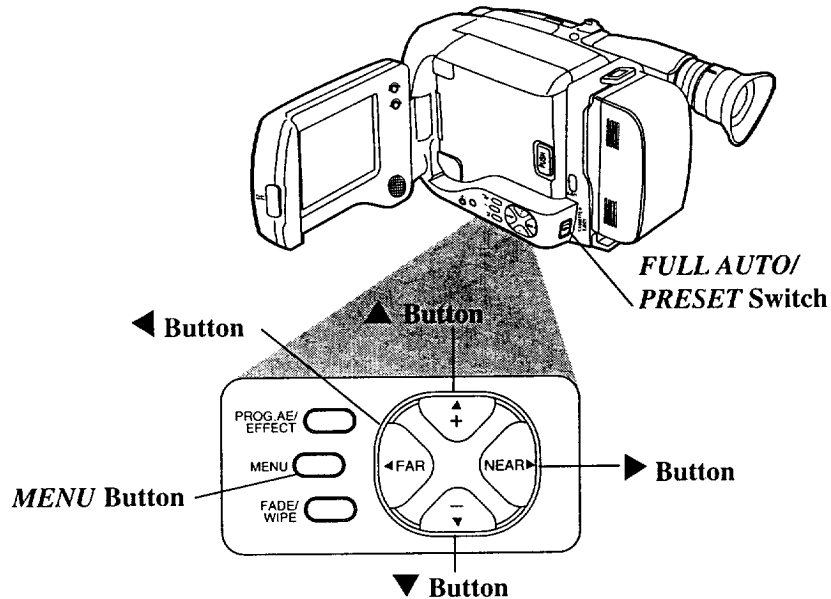

To Set Gain Up

1. Make sure the **FULL AUTO/PRESET** switch is in **PRESET**.
2. Press the **MENU** button. The recording menu will appear in the viewfinder or on the LCD monitor.
3. Press **▲** or **▼** to highlight **Gain Up**.
4. Press **◀** or **▶** to select **AGC** or **◆OFF**.
 - Select **◆OFF** when lighting is not a problem.
 - Select **AGC** to record a subject in a dark environment. The picture will be brighter, with slightly more “video noise”.
5. Press **MENU** to exit the menu.

Tele Macro	OFF
Gain Up	AGC
Color Filter	NOR.
Tape Length	T20
Title	
Date/Time	
Sub Menu	

3. Press **▲** or **▼** to highlight **Gain Up**.

Recording

Recording Menu — *Color Filter*

This feature allows you to add a red or blue tint to the recording.

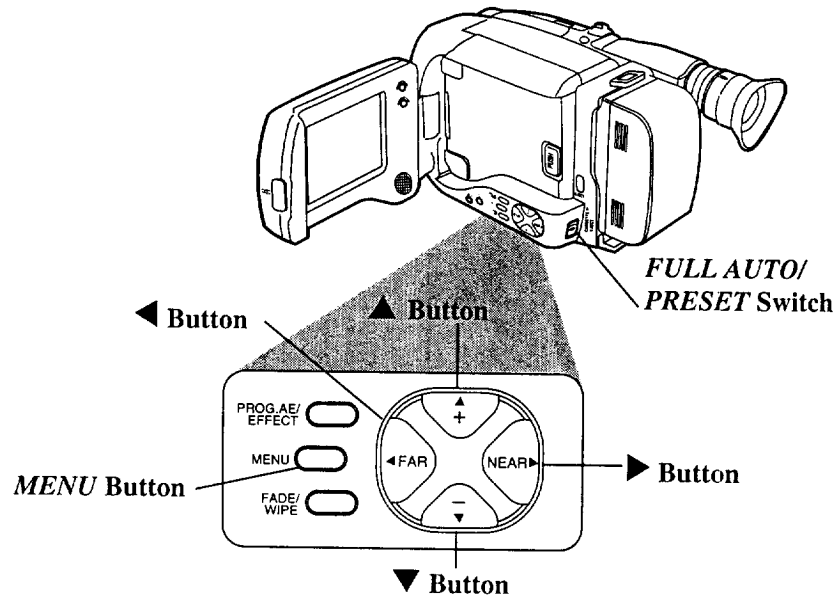

To Set *Color Filter*

1. Make sure the *FULL AUTO/PRESET* switch is in *PRESET*.
2. Press the *MENU* button. The recording menu will appear in the viewfinder or on the LCD monitor.
3. Press **▲** or **▼** to highlight *Color Filter*.
4. Press **◀** or **▶** to select *NOR.*, **◆RED**, or **◆BLUE**.
 - Select *NOR.* for normal recording
 - Select **◆RED** to add a reddish tint to your recording.
 - Select **◆BLUE** to add a bluish tint to your recording.
5. Press *MENU* to exit the menu.

Tele Macro	OFF
Gain Up	AGC
Color Filter	NOR.
Tape Length	T20
Title	
Date/Time	
Sub Menu	

3. Press **▲** or **▼** to highlight *Color Filter*.

Recording

Recording Menu — Tape Time-Remaining Display

The approximate time remaining on the tape in the camcorder is automatically displayed in the viewfinder. The *Tape Length* feature in the recording menu must be set correctly for the length tape you are using before the camcorder can correctly calculate time remaining.

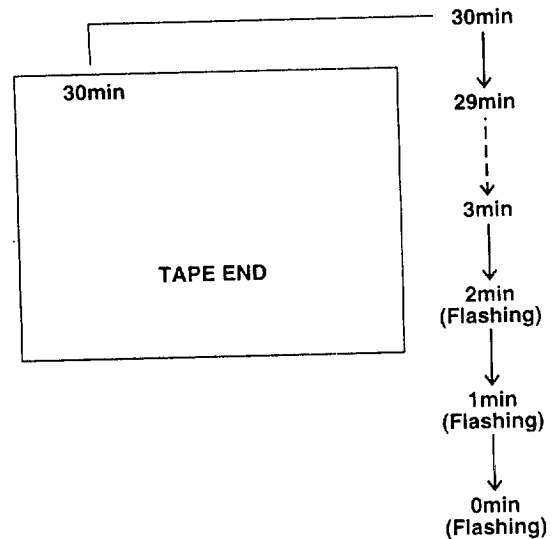
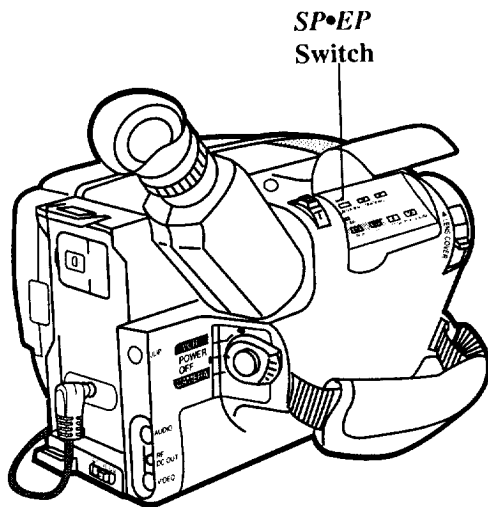

Set the Tape Length

1. Make sure the *FULL AUTO/PRESET* switch is in *PRESET*.
2. Press the *MENU* button. The recording menu will appear in the viewfinder or on the LCD monitor.

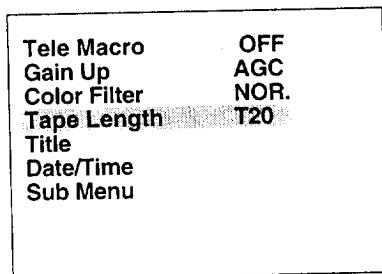

3. Press ▲ or ▼ to highlight *Tape Length*.
4. Press ◀ or ▶ to select the length of tape you are using:

- Select *T20* if you are using a tape with 20 minutes recording time in SP speed.
- Select *T30* if you are using a tape with 30 minutes recording time in SP speed.
- Select *T40* if you are using a tape with 40 minutes recording time in SP speed.

5. Press *MENU* to exit the menu.

Notes: The time-remaining indicator will start flashing when the remaining tape time reaches two minutes.

TAPE END appears when the tape reaches its end during recording or a cassette is loaded with its tape already at the end.

Recording

Recording Menu — Title

The title feature lets you choose one of eight preset titles or create your own title — up to 18 characters to superimpose on a scene. The clock cell battery must be installed *as shown on page 48* before you can create or store your own title.

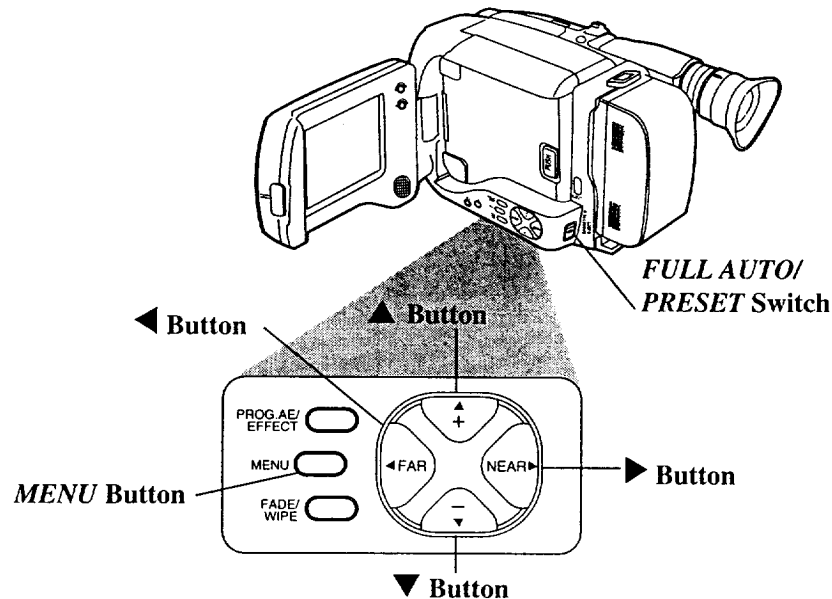

To Add a Preset Title to Your Recordings

1. Make sure the *FULL AUTO/PRESET* switch is in *PRESET*.
2. Press the *MENU* button. The recording menu will appear in the viewfinder or on the LCD monitor.
3. Press **▲** or **▼** on the mode select dial to highlight *Title*.
4. Press **▶** to display the title menu.

Tele Macro	OFF
Gain Up	AGC
Color Filter	NOR.
Tape Length	T20
Title	
Date/Time	
Sub Menu	

OFF
Happy Birthday
Our Vacation
Merry Christmas
A Special Day
Happy Holidays
Our New Baby
Wedding Day
Congratulations
(Set Character)

5. Press **▲** or **▼** to highlight the preset title you wish to use.
6. Press *MENU* to display the title in the viewfinder or on the LCD monitor. It will be superimposed on your tape during recording.

(continued on next page)

Recording

Recording Menu — *Title* (Continued)

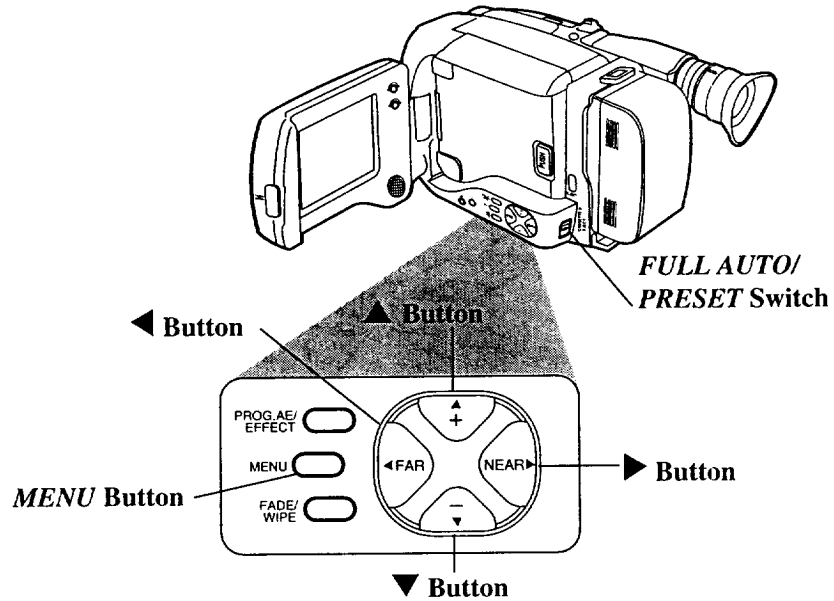

To Create Your Own Title

1. Make sure the *FULL AUTO/PRESET* switch is in *PRESET*.
2. Press the *MENU* button. The recording menu will appear in the viewfinder or on the LCD monitor
3. Press ▲ or ▼ to highlight *Title*.
4. Press ► to display the title menu.
5. Press ▲ or ▼ to highlight (*Set Character*).

Tele Macro	OFF
Gain Up	AGC
Color Filter	NOR.
Tape Length	T20
Title	
Date/Time	
Sub Menu	

OFF
Happy Birthday
Our Vacation
Merry Christmas
A Special Day
Happy Holidays
Our New Baby
Wedding Day
Congratulations
(Set Character)

Recording

6. Press **▶** to display the set character menu.

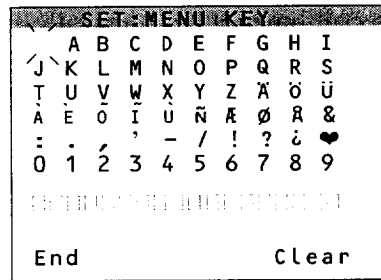

Note: If you wish to erase a previous title, highlight *Clear*, and press *MENU*.

7. Press **▲**, **▼**, **▶**, or **◀** to highlight the character you wish to use.
8. Press *MENU* to enter the character in your title.
9. Repeat steps 7 and 8 until you have completed your title (up to 18 characters).

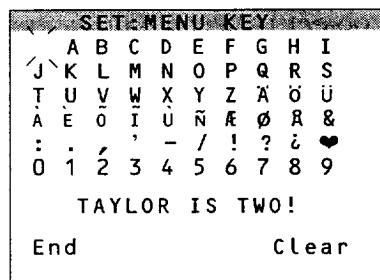

10. When you are finished, press **▲**, **▼**, **▶**, or **◀** to highlight *End*.

11. Press *MENU* to return to the title menu, or press *MENU* twice to remove all menus from the screen and display and record your title.

Note: The title will be recorded on your tape whenever it appears in the viewfinder or on the LCD monitor.

Notes: To select the location of a character, press **▲**, **▼**, **▶**, or **◀** to move the cursor to the row of squares at the bottom. Then press **▶** or **◀** to highlight the location where you want to place the character.

To correct a character, highlight the character you want to correct and press **▲** and **▼** together.

If you wish to erase a previous title or all characters, highlight *Clear*, and press *MENU*.

To Turn Off a Title

1. Display the title menu, use **▲** or **▼** to highlight *OFF* and press *MENU*.
2. Press *MENU* to remove the title menu from the screen.

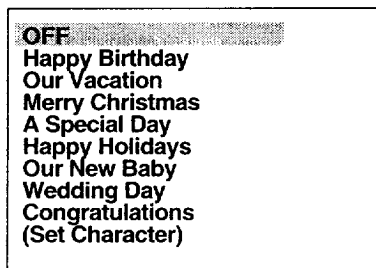

Recording

Date/Time Display — Install the Clock Lithium Cell

The clock cell indicator  will flash for a few seconds in the viewfinder or on the LCD monitor when you turn on the camcorder if the cell has not been installed or needs to be replaced.

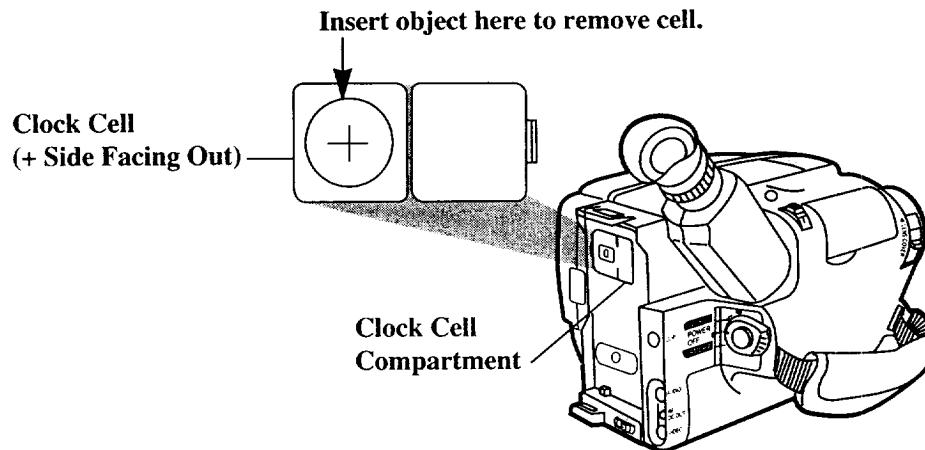

1. Make sure camcorder is turned off, and remove any power supply attached to the camcorder.
2. Press release tab of clock cell compartment cover and open the compartment.
3. Insert the clock cell with the “+” terminal facing out.
4. Close the compartment cover. It will click into place.

To Remove Battery

To remove battery, insert a pointed non-metallic object between battery and compartment and lift.

Cautions: Lithium cell battery. Replace only with 3-volt lithium cell – such as CR2025. Use of other cell presents a risk of fire or explosion. Must be disposed of properly. Never handle punctured or leaking cell. May cause burns or personal injury.

Keep out of the hands of children. Can cause death or injury if swallowed. If swallowed, consult a physician immediately for emergency treatment.

The lithium cell used in this device may explode resulting in a fire or chemical burn if mistreated. Do not recharge, disassemble, heat above 212°F (100°C), or incinerate.

Never use metallic tweezers to hold the cell, and never short circuit the + and – sides of the cell.

Recording

Recording Menu — Date/Time Display

The date and time must be set before it can be displayed and recorded on your tapes. The clock cell must be installed *as shown on the previous page* before the date can be set and recorded.

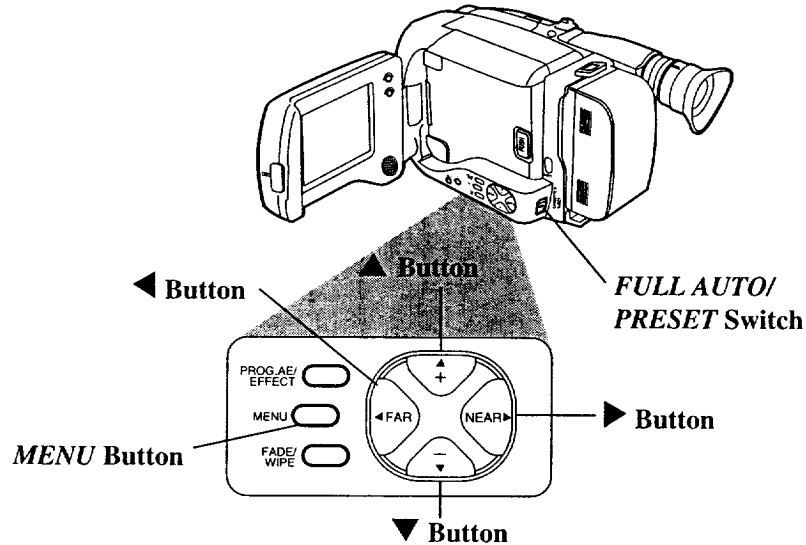

To Set the Date and Time

1. Make sure the *FULL AUTO/PRESET* switch is in *PRESET*.
2. Press the *MENU* button. The recording menu will appear in the viewfinder or on the LCD monitor.
3. Press ▲ or ▼ to highlight *Date/Time*.
4. Press ▶ to display the date and time screen.
5. Press ▲ or ▼ to enter the correct month. Press ▲ to go forward or ▼ to go back.
6. Press ▶ to start the day flashing.
7. Repeat steps 5 and 6 to set the year, hour (including AM and PM), and minutes.
8. Press ▲ or ▼ to highlight *Set*.
9. Press the *MENU* button. The camcorder's internal clock will start and you will return to the recording menu.

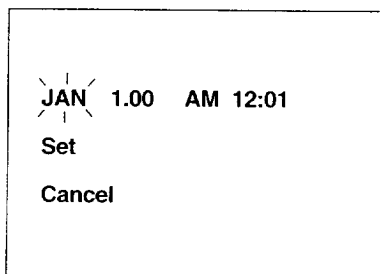
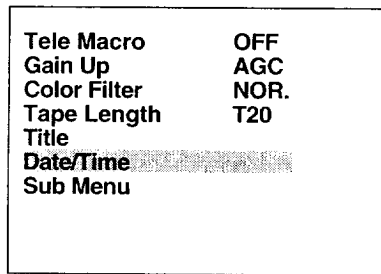

Note: If you want to return the date and time to the previous setting, press ▶ or ◀ to highlight *Cancel* and press *MENU*.

Notes: Press *MENU* twice to start the clock and remove all the menus from the viewfinder.

If you enter an invalid date, *Input Error* appears in the viewfinder. Press ▲, ▼, ▶, or ◀ and enter the correct day.

Recording

Date/Time Display

The clock cell must be installed and the date and time set before the date and/or time can be selected and recorded on your tape.

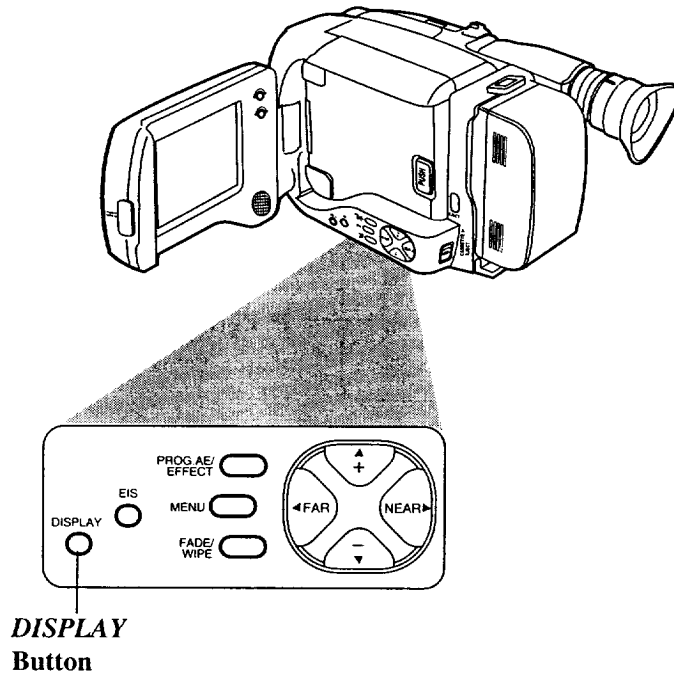

To Select the Date, Time, or Date and Time You Want to Record On Your Tape

1. Attach a power supply and place *POWER* switch in *CAMERA*. The power indicator will light.
 2. Repeatedly press *DISPLAY* to select the date, time, or date and time you want to record.
- **Date Display:** The date will be displayed and recorded.
 - **Time:** The time will be displayed and recorded.
 - **Date and Time Display:** The date and time will be displayed and recorded.
 - **Date and Time Off:** No date or time will be displayed or recorded.

Recording

Date/Time Display

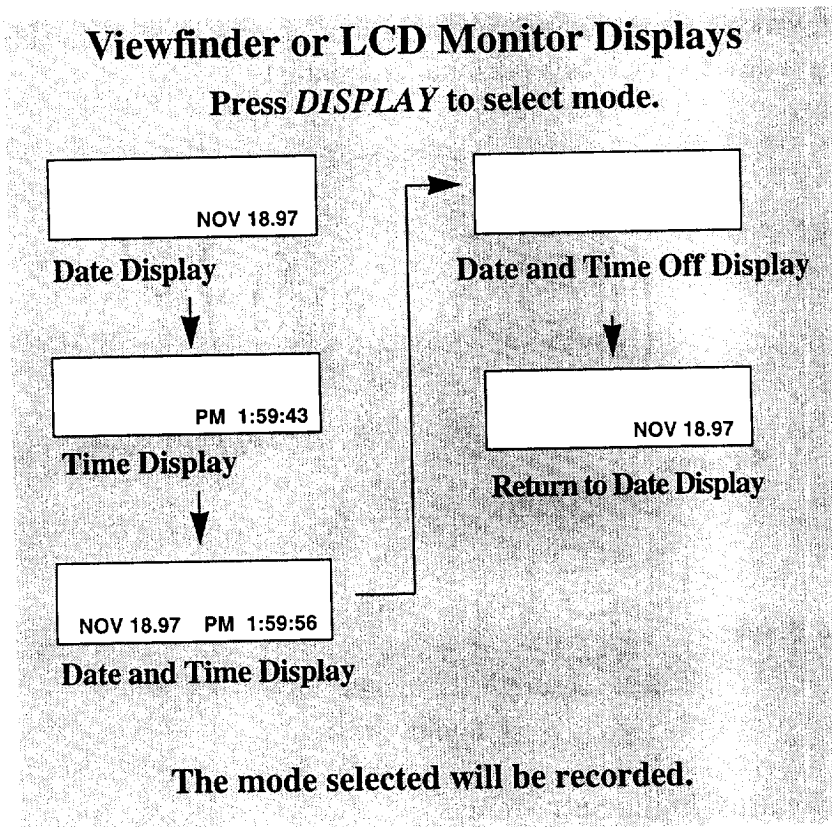

To Record the Date, Time, or Date and Time on Your Tape

1. Place the camcorder in record pause.
2. Repeatedly press the *DISPLAY* button to display the date, time, or date and time you have previously stored.
3. Begin recording.
4. Press the *DISPLAY* button to remove the display from the viewfinder when you are finished recording it.
5. To record the display again, place the camcorder in record pause and press the *DISPLAY* button to select the mode you want to record.

Note: If you do not want to record a date or time, press *DISPLAY* to select the date and time off mode.

Recording

Recording Menu — Sub Menu

The sub menu lets you turn the tally light on or off, set interval and recording times for the self-timer, time-lapse recording, or animation recording. You can also set a JLIP ID number for a device (such as a personal computer).

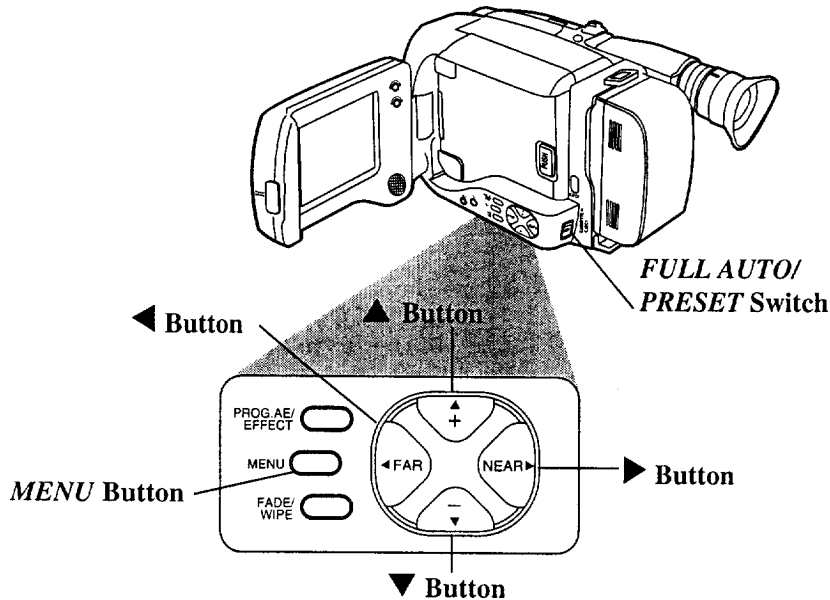

To Change a Feature in the Sub Menu

1. Make sure the *FULL AUTO/PRESET* switch is in *PRESET*.
2. Press the *MENU* button. The recording menu will appear in the viewfinder or on the LCD monitor.

Tally	ON
Interval Timer	OFF
Rec Time	OFF
JLIP ID NO.	07

Tele Macro	OFF
Gain Up	AGC
Color Filter	NOR.
Tape Length	T20
Title	
Date/Time	
Sub Menu	

3. Press ▲ or ▼ to highlight *Sub Menu*.
4. Press ► to display the sub menu.
5. Press ▲ or ▼ to highlight the item you want to adjust.

6. Press ► to start the highlighted item flashing.
7. Press ▲ or ▼ to adjust the highlighted item.
Note: If you want to change another feature, repeat steps 5, 6, and 7.
8. Press ◀ to return to the recording menu, or press *MENU* to exit both menus.

Recording

Sub Menu — *Tally Light* and *JLIP ID NO.*

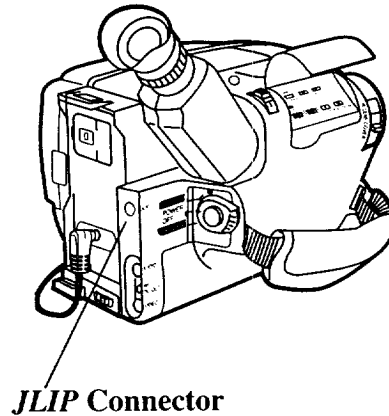
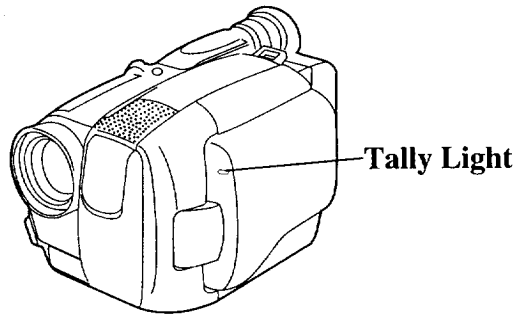

To Turn the Tally Light *ON* or *OFF*

1. Follow steps 1-4 *on the previous page*.
2. Press ▲ or ▼ to highlight *Tally*.
3. Press ► to start *Tally* flashing.
4. Press ▲ or ▼ to turn the tally light *ON* or *OFF*.
 - Select *ON* to have the tally light turn on during recording.
 - Select *OFF* if you do not want the tally light to light.
5. Press ◀ to stop *Tally* flashing and return to the recording menu, or press *MENU* to exit both menus.

Tally	ON
Interval Timer	OFF
Rec Time	OFF
JLIP ID NO.	07

3. Press ► to start *Tally* flashing.

Set the *JLIP ID NO.*

The camcorder has a *JLIP* (Joint Level Interface Protocol) connector that may be used in the future to connect a device, such as a home computer.

To Select a *JLIP ID NO.*

1. Follow steps 1-4 *on the previous page*.
2. Press ▲ or ▼ to highlight *JLIP ID NO.*
3. Press ► to start *JLIP ID NO.* flashing.
4. Press ▲ or ▼ to select a number from 01 to 99.
5. Press ◀ to stop *JLIP ID NO.* flashing and return to the recording menu, or press *MENU* to exit both menus.

Tally	ON
Interval Timer	OFF
Rec Time	OFF
JLIP ID NO.	07

Recording

Sub Menu — Self-Timer

The self-timer lets you set the camcorder to delay recording so you can be in the scene when recording begins.

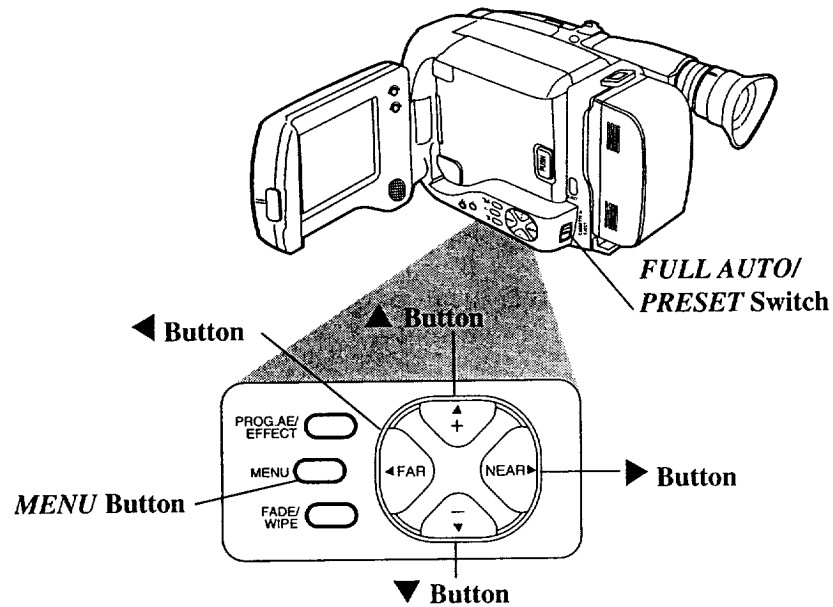

To Set the Self-Timer

1. Place the *POWER* switch in *CAMERA*. The power indicator will light.
2. Place *FULL AUTO/PRESET* switch in *PRESET*.
3. Press the *MENU* button. The recording menu will appear in the viewfinder or on the LCD monitor.
4. Press ▲ or ▼ to highlight *Sub Menu*.
5. Press ► to display the sub menu.

Tele Macro	OFF
Gain Up	AGC
Color Filter	NOR.
Tape Length	T20
Title	
Date/Time	
Sub Menu	

Recording

6. Press ▲ or ▼ to highlight *Interval Timer*.

Tally	ON
Interval Timer	OFF
Rec Time	OFF
JLIP ID NO.	07

7. Press ► to start *Interval Timer* flashing.

Tally	ON
Interval Timer	OFF
Rec Time	OFF
JLIP ID NO.	07

15S
 ↓
 30S
 ↓
 1min
 ↓
 5min
 ↓
 OFF

8. Press ▲ or ▼ to select the amount of time you want the recording delayed.
- Select *15S* to delay the recording for 15 seconds.
 - Select *30S* to delay the recording for 30 seconds.
 - Select *1min* to delay the recording for one minute.
 - Select *5min* to delay the recording for five minutes.
 - Select *OFF* if you do not want the camcorder to delay recording.

9. Press ◀ twice to return to the recording menu.

10. Press *MENU* to exit the menu. ☺ and the amount of delayed recording time appear in the viewfinder or on the LCD monitor.

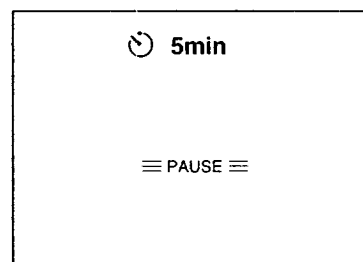

Self-Timer Indicator in Viewfinder or on LCD Monitor

11. Press the thumb trigger to start self-timer recording. The camcorder will start recording after the amount of time you have set. It will continue recording until you press the thumb trigger to stop recording.

Notes: If the tally light is turned on, it starts flashing. About five seconds before recording begins, the tally light will start flashing faster. It will stop flashing when recording begins.

To stop self-timer recording before it has started, press the thumb trigger again, and set the *Interval Timer* to *OFF*.

12. Turn off the interval time when you are finished by selecting *Interval Time OFF* in the *Sub Menu*.

Recording

Sub Menu — Animation Recording

Animation recording produces an illusion of movement for an otherwise stationary scene or object by shooting a series of pictures of slightly different poses (such as cartooning).

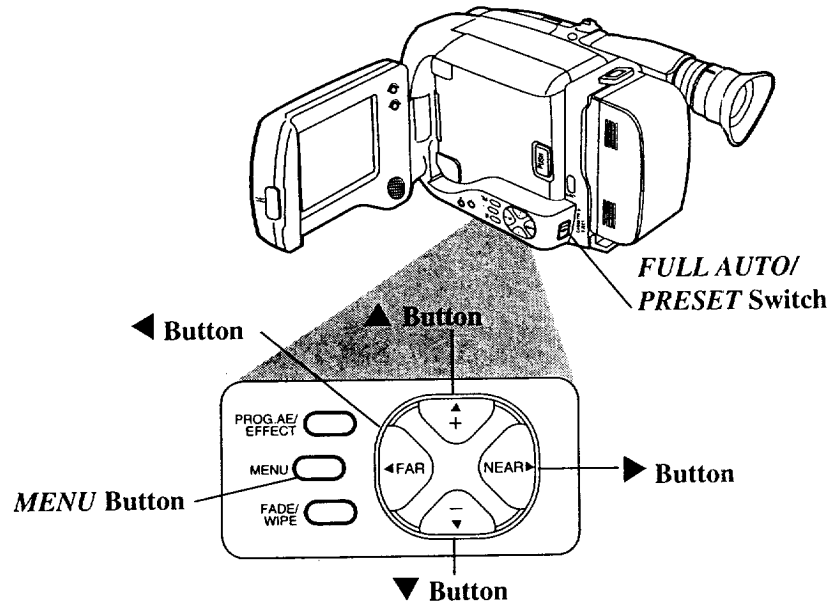

To Record Using Animation

1. Place the *POWER* switch in *CAMERA*. The power indicator will light.
2. Place *FULL AUTO/PRESET* switch in *PRESET*.
3. Make sure the recording speed is set to *SP*.
4. Press the *MENU* button. The recording menu will appear in the viewfinder or on the LCD monitor.

Tele Macro	OFF
Gain Up	AGC
Color Filter	NOR.
Tape Length	T20
Title	
Date/Time	
Sub Menu	

Recording

5. Press ▲ or ▼ to highlight *Sub Menu*.
6. Press ► to display the sub menu.

Tally	ON
Interval Timer	OFF
Rec Time	OFF
JLIP ID NO.	07

7. Press ▲ or ▼ to highlight *Rec Time*.
8. Press ► to start *Rec Time* flashing.

Tally	ON
Interval Timer	OFF
Rec Time	OFF
JLIP ID NO.	07

- 1/4S
- ↓
- 1/2S
- ↓
- 1S
- ↓
- 5S
- ↓
- OFF

9. Press ▲ or ▼ to select the amount of time you want the camcorder to record.
 - Select *1/4S*, *1/2S*, *1S*, or *5S* to have the camcorder record for 1/4 second, 1/2 second, one second, or five seconds.
 - Select *OFF* to turn off the recording time.

10. Press *MENU* to select a recording time.
11. Press *MENU* to exit the menu.
 - ◀ and the amount of recording time appear in the viewfinder or on the LCD monitor.

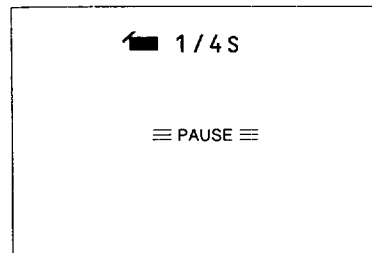

12. Press the thumb trigger to start recording.

Note: The recording stops automatically after the selected period of recording time. You may want to take two to five shots of the subject in the same position.

13. Move the subject and repeat step 11 for the desired number of shots.
14. Turn off the recording time when you are finished by selecting *Rec Time OFF* in the *Sub Menu*.

Note: Fades and wipes do not operate during animation recording.

Recording

Sub Menu — Time-Lapse Recording

Time-lapse recording makes automatic recordings at preset time intervals. The recording will show subtle changes (such as shifts in cloud formations or plant growth) when it remains focused on an object.

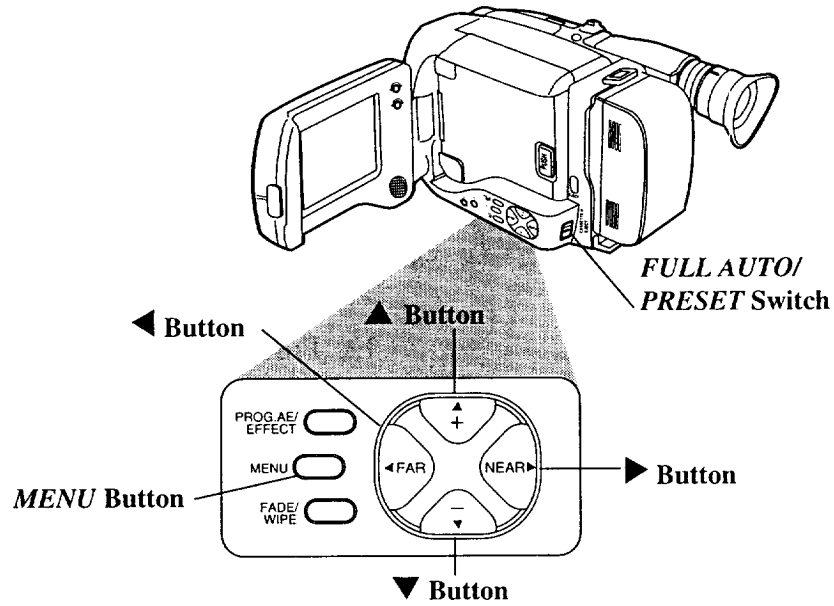

To Record Using Time Lapse

1. Place the *POWER* switch in *CAMERA*. The power indicator will light.
2. Place *FULL AUTO/PRESET* switch in *PRESET*.
3. Make sure the recording speed is set to *SP*.
4. Press the *MENU* button. The recording menu will appear in the viewfinder or on the LCD monitor.
5. Press **▲** or **▼** to highlight *Sub Menu*.

Tele Macro	OFF
Gain Up	AGC
Color Filter	NOR.
Tape Length	T20
Title	
Date/Time	
Sub Menu	

Recording

6. Press **▶** to display the *Sub Menu*.

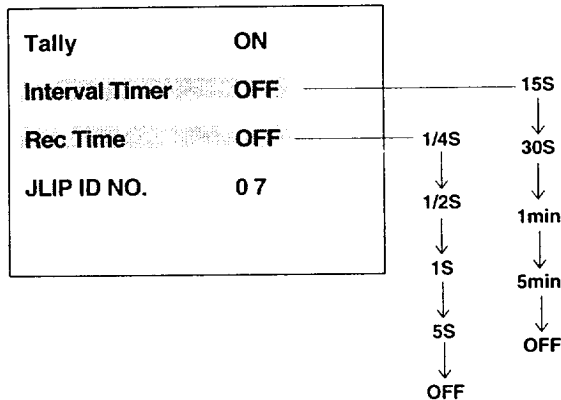

7. Press **▲** or **▼** to highlight *Rec Time*.

8. Press **▶** to start *Rec Time* flashing.

9. Press **▲** or **▼** to select the amount of time you want the camcorder to record.

- Select *1/4S*, *1/2S*, *1S*, or *5S* to have the camcorder record for 1/4 second, 1/2 second, one second, or five seconds.
- Select *OFF* to turn off the recording time.

10. Press **▼** to highlight *Interval Timer*.

11. Press **▶** to start *Interval Timer* flashing.

12. Press **▲** or **▼** to select the amount of time you want between recordings.

- Select *15S*, *30S*, *1min*, or *5min* to set the intervals between recording to 15 seconds, 30 seconds, one minute, or five minutes.
- Select *OFF* to turn off the *Interval Timer*.

13. If necessary, adjust the exposure control, focus, and stabilizer before step 14.

14. Press **MENU** to exit the menu. **←** and the amount of recording time, and **⊙** and the amount of interval time appear in the viewfinder or on the LCD monitor.

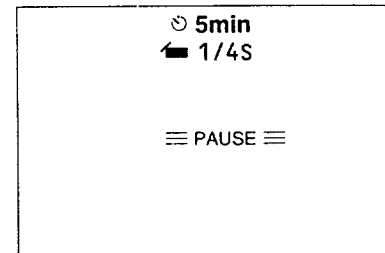

15. Press the thumb trigger to start recording.

Notes: The camcorder will start and stop recording the selected amount of time.

If the tally light is turned on, it flashes with the flash speed increasing five seconds before recording begins.

16. Turn off the interval and recording time when you are finished by selecting *Interval Timer OFF* and *Rec Time OFF* in the *Sub Menu*.





Note: Fades and wipes do not operate during time-lapse recording.

Recording

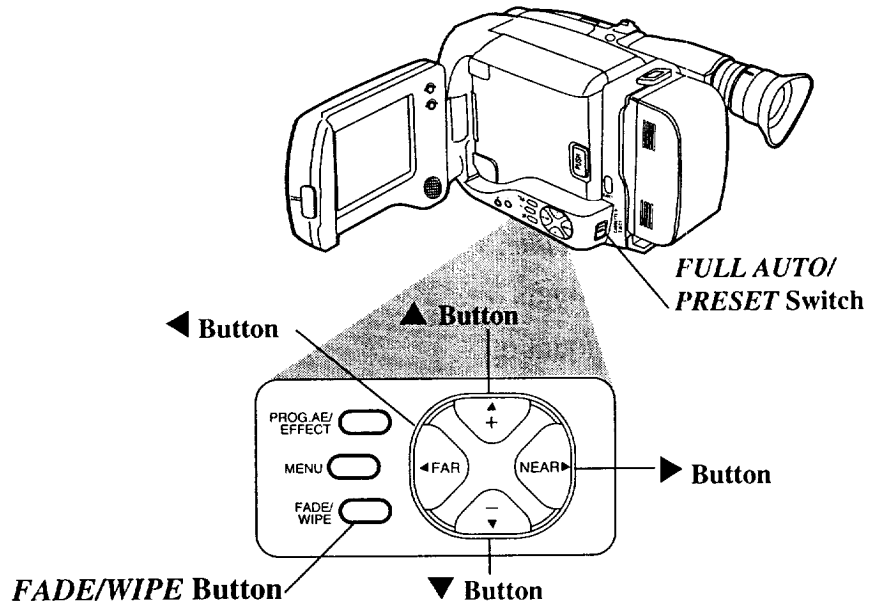
Fading or Wiping In and Out

You can add a professional touch to your recordings when you use the fade or wipe features. The picture gradually appears on a black or blue screen and disappears leaving a black or blue screen. The speed of the fade or wipe is automatically controlled by the camcorder.



Indicator	Menu	Function
	<i>Black Fader</i>	Fades in or out on a black screen.
	<i>Blue Fader</i>	Fades in or out on a blue screen.
	<i>Mosaic Fader</i>	Fades in or out with a full screen mosaic effect.
	<i>Shutter Wipe</i>	Wipes in with a black screen from the top and bottom. Wipes out from the center towards the top and bottom leaving a black screen.
	<i>Slide Wipe</i>	Wipes in with a black screen from the left. Wipes out with the image moving from right to left leaving a black screen.

Recording

To Fade or Wipe

1. Place the *POWER* switch in *CAMERA*. The power indicator will light.
2. Place *FULL AUTO/PRESET* switch in *FULL AUTO* or *PRESET*.

- ***FULL AUTO/PRESET* Switch in *FULL AUTO***

Press the *FADE/WIPE* button to turn the black fader on or off.

Bk appears in the viewfinder or on the LCD monitor.

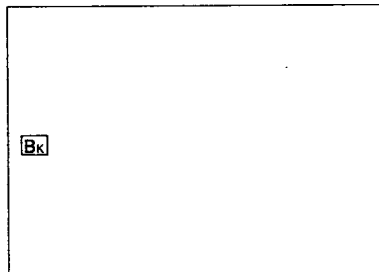

Note: This is the only fade you can use in the full auto mode.

- ***FULL AUTO/PRESET* Switch in *PRESET***

Press the *FADE/WIPE* button to display the fade/wipe menu.

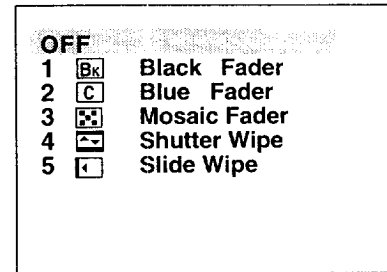

3. Press *FADE/WIPE* to highlight the fade or wipe you want to select.

Note: The fade or wipe you select is automatically activated and the fade/wipe menu is removed from the viewfinder or LCD monitor in approximately two seconds.

4. Press the thumb trigger to start recording and fade or wipe in.

Note: If you select a fade or wipe during recording, press the thumb trigger to fade or wipe out.

To Turn Off Fade or Wipe

When *FULL AUTO/PRESET* switch is in *FULL AUTO*, press *FADE/WIPE*.

When *FULL AUTO/PRESET* switch is in *PRESET*, press *FADE/WIPE* to display the fade/wipe menu, and then press *FADE/WIPE* repeatedly to highlight *OFF*.

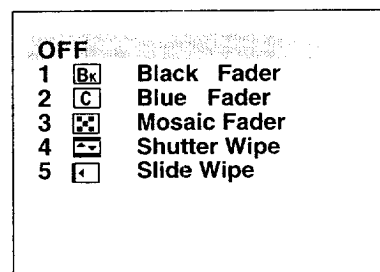

Note: The fade or wipe will be turned off and the menu will automatically be removed from the viewfinder or LCD monitor in approximately two seconds.

Recording

Production Effects

You can add a professional touch to your recordings when you use some of the production effects while recording.

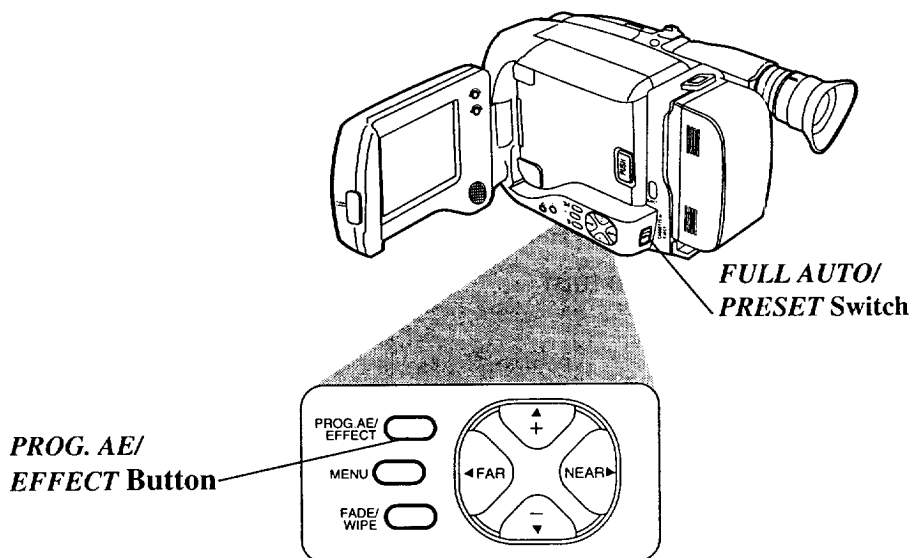

Indicator	Menu	Function
	<i>Cinema</i>	The camcorder records black bars at the top and bottom of the picture to produce the wide-screen effect. This is also known as "letter box" recording. Use when you play back your recordings on a 16X9 TV.
	<i>Sepia</i>	Gives your recording a brownish tint like old photos. Combine with cinema mode for a classic look.
	<i>Twilight</i>	Use to record a scene at dusk or twilight. Also used to record fireworks for a more natural and dramatic look. Auto gain is turned off, and white balance is set to outdoors.
	<i>Sports</i>	Use to clearly capture fast-moving action with less blurring. Use when playing back the recording on a VCR featuring special effects, such as pause or slow motion.
	<i>Hi.S 1/2000</i>	Sets shutter speed to 1/2000. Use to record fast-moving action with less blurring. Can capture faster action than sports mode. Use outdoors and in well-lit situations when playing back recording on VCR featuring special effects, such as pause or slow motion.

Recording

To Use a Production Effect

1. Place the *POWER* switch in *CAMERA*. The power indicator will light.
2. Place *FULL AUTO/PRESET* switch in *FULL AUTO* or *PRESET*.

- ***FULL AUTO/PRESET* Switch in *FULL AUTO***

Press the *PROG.AE/EFFECT* button to turn the *Cinema* mode on or off.

appears in the viewfinder or on the LCD monitor.

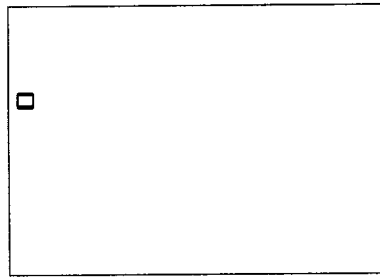

Note: This is the only production effect you can use in *FULL AUTO*.

- ***FULL AUTO/PRESET* in *PRESET***
Press the *PROG.AE/EFFECT* button to display the production effect menu.

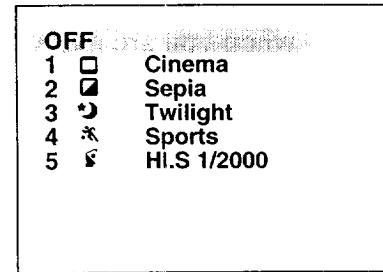

3. Press *PROG.AE/EFFECT* to highlight the effect you want to select.

Note: The effect you select is automatically activated and the menu is removed from the viewfinder or LCD monitor in approximately two seconds.

4. Press the thumb trigger to start recording with the effect you selected.

Notes: When *Sepia* is activated, pressing *MAN.W.BAL.* has no effect.

Certain effects cannot be used together with other functions. When an effect not suitable in the current situation is selected, its indicator flashes in the viewfinder or in the LCD monitor.

To Turn Off a Production Effect

When *FULL AUTO/PRESET* switch is in *FULL AUTO*, press *PROG.AE/EFFECT*.

When *FULL AUTO/PRESET* switch is in *PRESET*, press *PROG.AE/EFFECT* to display the production effect menu, and then press *PROG.AE/EFFECT* repeatedly to highlight *OFF*.

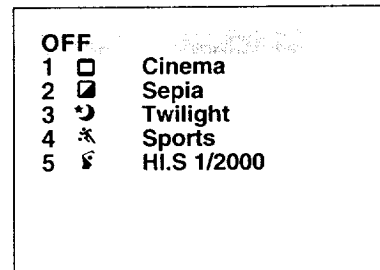

Note: The effect will be turned off and the menu will automatically be removed from the viewfinder or LCD monitor in approximately two seconds.

Attaching the Shoulder Strap

The camcorder's shoulder strap is designed to let you carry the camcorder from your shoulder and – when you are ready to shoot – bring the camcorder to shooting position in one quick movement.

To Attach the Shoulder Strap

1. If the strap keeper is over a double section of the strap, slide the strap keeper off the end of the strap. Replace the keeper on the strap between the buckle and the end of the strap as shown.

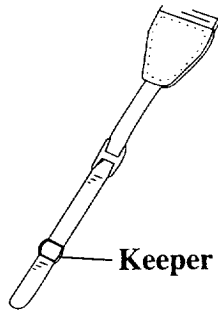

2. Loop the end of the strap over the top of the shoulder strap attachment ring.

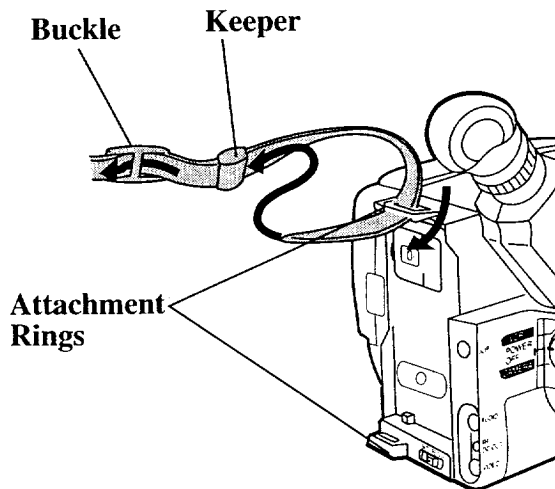

3. Thread the end of the strap back through the keeper and buckle making sure it is threaded **under** the outer strap. Make sure the strap is not twisted.

4. Attach the other end of the strap to the other shoulder strap attachment ring.

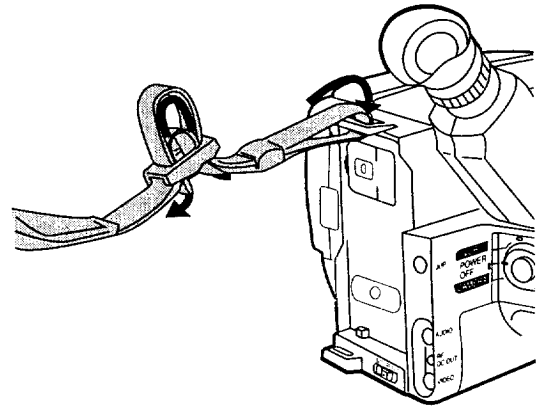

5. Adjust the shoulder strap to the desired length.
6. Slide both keepers up snugly against the shoulder strap attachment rings to prevent the strap from slipping.

Cautions: When carrying the camcorder with the shoulder strap, close and lock the LCD monitor and rotate the viewfinder down and slide it to the front. This helps prevent possible damage from bumping against your body as you move. Make sure the shoulder strap is firmly attached before using it to carry the camcorder.

Traveling Tips

- Write down your camcorder's serial number and keep it separate from the camcorder when traveling. If your camcorder is lost or stolen, you will be able to identify it.
- Use extra care to avoid damage to your camcorder and accessories when operating them at a beach or pool. Spray, sand, and dust should be avoided. If your lens has been exposed to the elements, clean it only with proper lens cleaning supplies.
- Make sure you have any plug adapters that you may need before taking your camcorder to other countries. Consult your dealer for advice.
- Carry your camcorder in a carrying case when traveling. *See page 76* for a case designed especially for this camcorder. An ordinary suitcase or carry bag does not offer the protection your camcorder needs. Treat your camcorder as carry-on luggage to protect it from rough handling.

Playback

Playback Using the LCD Monitor or Viewfinder

You can view tapes in color using the LCD monitor or black-and-white using the viewfinder. You can hear the sound from the tapes on the built-in speaker when you use the monitor.

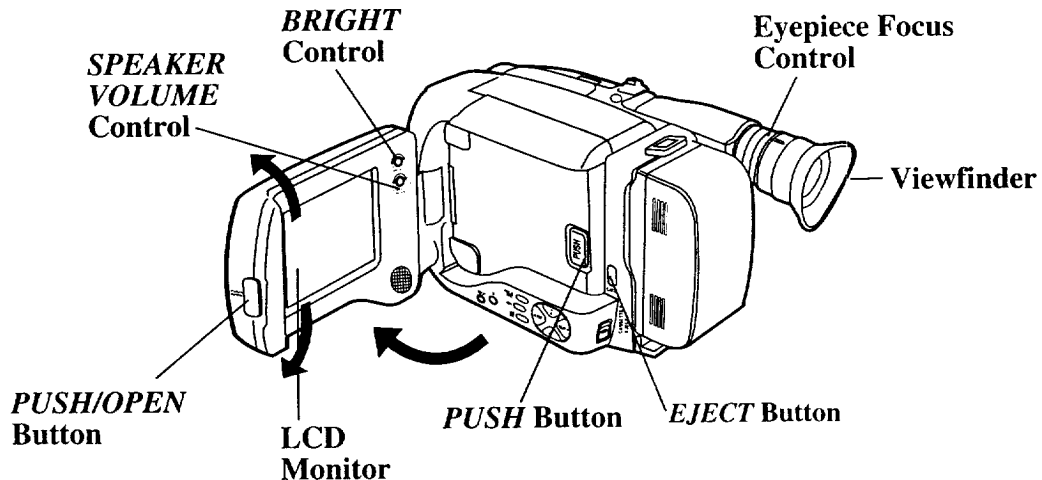

To Play Back a Tape

1. Attach a power supply.

Attach the adapter/charger, charged battery, or optional DC car cord.

2. Insert a tape.

- Press *PUSH/OPEN* to open the LCD monitor. Open the monitor at least 60° before opening the cassette compartment.
- Press *EJECT* to open the cassette compartment.
- Turn the tape wheel on the cassette to remove any slack from the tape.
- Insert the cassette with the tape wheel facing up and the tape window facing out.
- Press the *PUSH* button to lock the cassette compartment closed.

3. Place the *POWER* switch in *VCR*.

The power indicator will light.

4. Use the LCD monitor or viewfinder to view what you are recording.

Use the LCD Monitor

- Make sure the monitor is open at least 60°. The viewfinder will be automatically turned off.
- Tilt the LCD monitor (up to 45° up or down).
- Adjust the brightness of the image by turning the *BRIGHT* dial.
- Adjust speaker volume with the *SPEAKER VOLUME* control.

Use the Viewfinder

- Make sure the monitor is closed and locked. The viewfinder will be automatically turned on.
- Adjust the viewfinder for a comfortable viewing condition.
- Turn the eyepiece focus control to adjust the focus of the viewfinder for your vision.

5. Press *PLAY/PAUSE* to begin playback.

- If necessary, adjust tracking.
- During playback, use the playback features on the next pages.

6. Press *STOP* when you are finished.

Playback

Playback Features

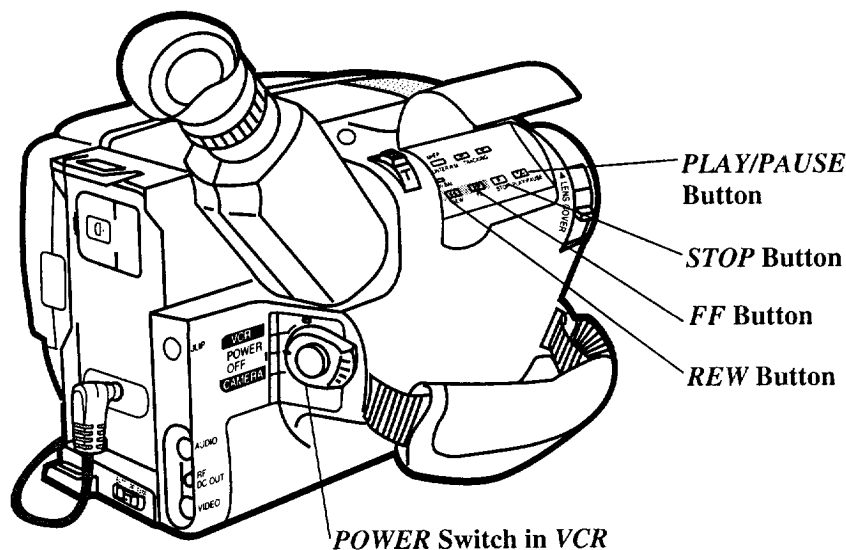

Visual Searching

- During playback, press and release *FF* or *REW* if you want to search the tape visually in forward or reverse.
- Press *PLAY/PAUSE* on the camcorder to return to normal playback.
- For brief searching, press and hold *FF* or *REW* for more than two seconds.
- Release the button to return to normal playback.

Note: Noise bars may appear and the picture may become monochrome or darken during searching.

Tape Positioning

Place *POWER* switch in *VCR* and press *STOP*.

- Press *REW* or *FF* to rewind or fast-forward the tape.
- Press *STOP* to stop the tape.

Stop-Action Pause

- During playback, press *PLAY/PAUSE* to “stop the action” and view one frame of the tape.
- Press *PLAY/PAUSE* on the camcorder to return to normal playback.

Caution: Pause is designed for momentary interruptions and should not be used for an extended period of time. If the camcorder remains in pause for more than five minutes, it will automatically enter the stop mode and then turn off to prevent excessive tape wear.

Playback

Playback Features (Continued)

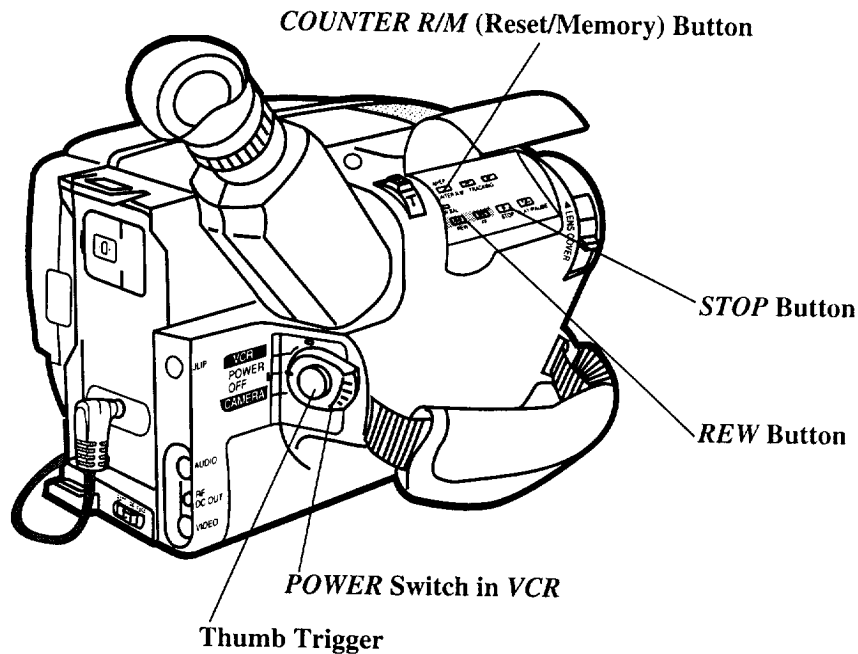

Time Counter

The time-counter display shows the actual time elapsed when playing back a segment of tape. The memory-stop feature helps locate a certain point on the tape. When memory stop is on, the tape will stop automatically during rewind or fast forward when the time counter reaches *M 0:00:00*.

To Use the Memory-Stop Feature

1. Place the *POWER* switch in *VCR*, locate the place on the tape you want to return to, and press *COUNTER R/M* for more than two seconds to reset the counter to 0:00:00.
2. Press *COUNTER R/M* again to turn on memory stop. An *M* appears before the time counter.
3. Continue to play the tape. When you want to return to the place you marked, press the *STOP* button.
4. Press *REW*. The tape will rewind to the time counter reading of *M 0:00:00*.
5. Press *COUNTER R/M* to turn off memory stop. The *M* disappears.

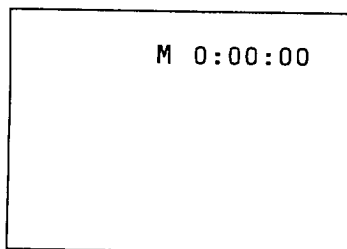

Time Counter With
Memory Stop Turned On

Note: The time counter does not operate on blank portions of tape.

Playback

Playback Features (Continued)

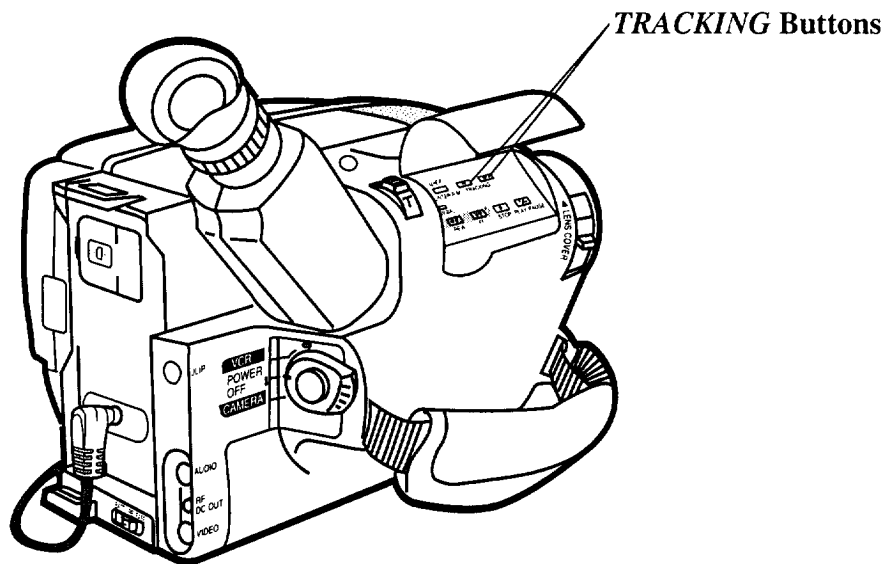

Tracking

During playback, streaks may appear in the playback picture. Press either *TRACKING* button to move the streaks up or down and out of the picture.

- During stop-action playback, pressing one of the *TRACKING* buttons may reduce picture "jitter" (picture bouncing up and down). Some "jitter" is normal.

Simultaneously press both *TRACKING* buttons to return tracking to its preset center.

Note: The *TRACKING* buttons may have no effect on tapes recorded on other camcorders or VCRs.

Playback

Playback on TV (or VCR) with *AUDIO/VIDEO IN* Jacks

To connect your camcorder to a TV monitor (or VCR) with *AUDIO/VIDEO IN* jacks, you will need an optional audio/video cable such as VH83 shown on page 78.

If your TV is already connected to a VCR, you can attach the camcorder to the VCR and watch what the camcorder is recording or playing on the TV.

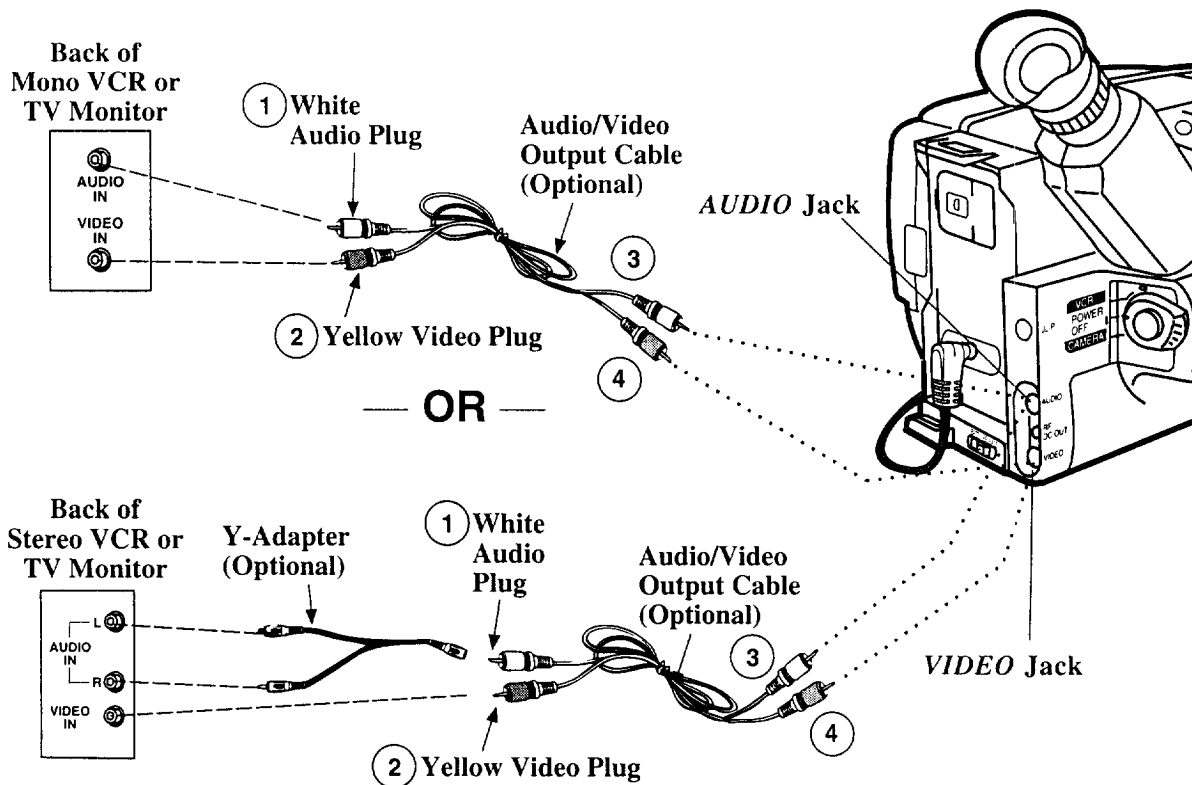

Installation

- 1 Attach the white plug on one end of the audio/video cable to the *AUDIO IN* jack on the TV (or VCR).
Notes: If your cable does not have white and yellow plugs, just be sure to attach the same color to the audio jacks.
If your TV (or VCR) has stereo *AUDIO IN* jacks, attach the plug to the one labeled *MONO*. If one is not labeled *MONO*, you may need a Y-adaptor, such as AH25, shown on page 78 to hear both channels.
- 2 Attach the yellow plug to the *VIDEO IN* jack on the TV (or VCR).
- 3 Attach the white plug on the other end of the audio/video cable to the *AUDIO* jack (located under the small cover) on the back of the camcorder.
- 4 Attach the yellow plug to the yellow *VIDEO* jack on the camcorder.

Playback

Playback Operation and How to Copy Tapes on the VCR

1. A. Camcorder connected directly to TV: Turn on the TV and tune it to the video input channel.
B. Camcorder connected to VCR that is already connected to TV: Turn on VCR and place it in the line, video, or camera mode. (If your VCR does not have a line, video, or camera mode, consult the VCR owner's manual.) Operate the TV as you normally do to see the signal coming from the VCR.
2. Place the *POWER* switch in VCR to turn on the camcorder. The power indicator will light.
3. Press *PLAY/PAUSE*.
 - During playback, use the playback features *described on pages 69-70*.
4. To copy what the camcorder is playing, place a blank cassette in the VCR, and press the VCR's *RECORD* button.
Make sure the memory-stop feature is turned off (press *COUNTER R/M*) or the camcorder will enter play pause when the counter reaches *M 0:00:00*.
5. Press *STOP* when you are finished.

Caution: The unauthorized recording of copyrighted material may infringe the rights of others.

Viewing What the Camcorder is Seeing (or Recording)

1. A. Camcorder connected directly to TV: Turn on the TV, and tune it to the video input channel.
B. Camcorder connected to VCR that is already connected to TV: Turn on VCR and place it in the line, video, or camera mode. (If your VCR does not have a line, video, or camera mode, consult the VCR owner's manual.) Operate the TV as you normally do to see the signal coming from the VCR.
2. Place the *POWER* switch in *CAMERA*.
3. Press the thumb trigger to begin recording. You can watch what the camcorder is seeing (or recording) on the TV screen.
Notes: When the camcorder is used as a camera, turn the TV's volume down to prevent a high-pitched squeal caused by feedback.
4. Press the thumb trigger on the camcorder to pause recording.

Playback

Playback on a TV Without Audio/Video Inputs

To connect your camcorder to a TV without audio/video inputs, you will need an optional 1CVA147C RF output adapter and an optional coaxial RF cable, such as VH82 or VH90 shown on page 78. If your TV has *AUDIO* and *VIDEO IN* jacks (or is connected to a VCR), refer to pages 72-73.

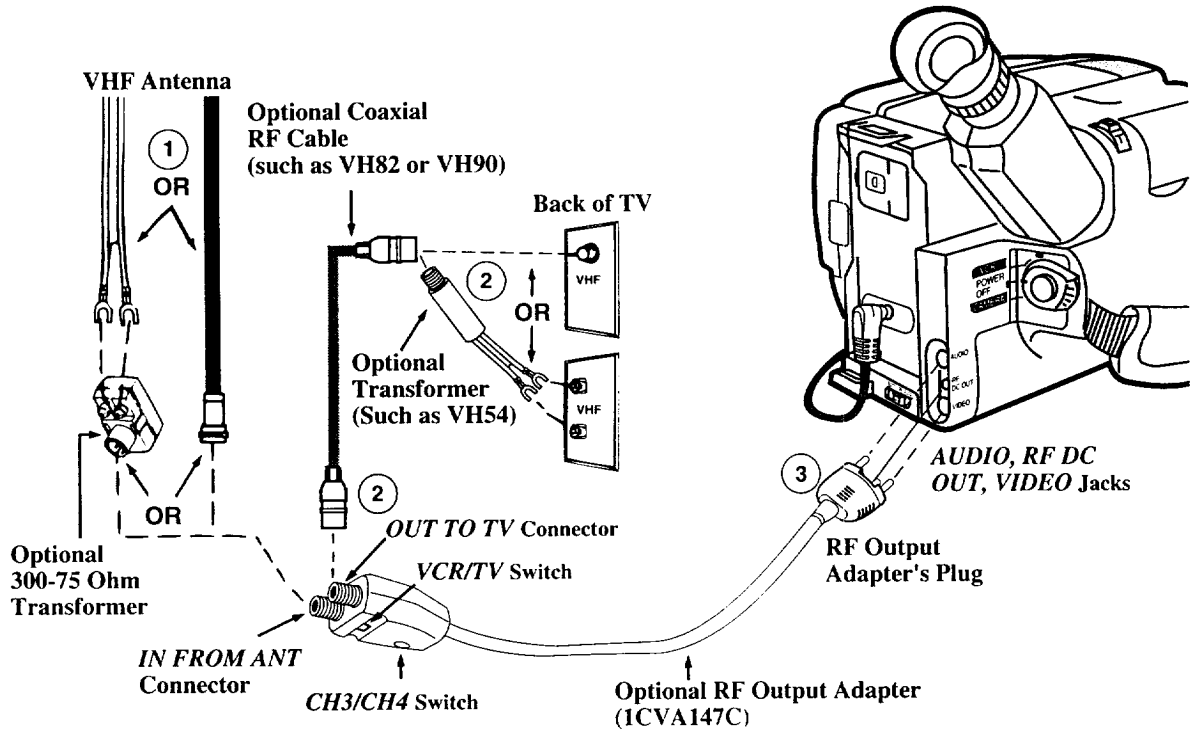

Installation

- ① Disconnect the VHF antenna from your TV. Connect the antenna to the *IN FROM ANT* connector on the RF output adapter if you are going to leave the adapter connected to the TV.

Note: If your VHF antenna is the flat twin-lead type attached by two screws, you will also need an optional 300/75 ohm transformer.

- ② Attach one end of the optional coaxial RF cable to the *OUT TO TV* connector on the adapter, and attach the other end to the VHF input on your TV as shown.

Note: If your TV has 300 ohm screw terminals, you will need a 75/300 ohm transformer, such as VH54, shown on page 78.

- ③ Attach the RF output adapter's plug to the *AUDIO, RF DC OUT*, and *VIDEO* jacks located under the small cover on the back of the camcorder.

Playback

Playback Operation

1. Set the *CH3/CH4* switch on the RF output adapter to channel 3 or 4.
2. Turn on the TV, and tune it to the same channel you selected with the RF output adapter's *CH3/CH4* switch.
3. Place adapter's *VCR/TV* switch in *VCR*.
4. Place *POWER* in *VCR*. Power indicator will light.
5. Press *PLAY/PAUSE* on the camcorder.
 - During playback, use the playback features described on pages 69-70.
 - If noise bars appear on the screen, adjust tracking as described on page 71.
6. Press *STOP* on the camcorder when you are finished.

Viewing What the Camcorder Is Recording

1. Turn on the TV and tune it to channel 3 or 4.
2. Set the *CH3/CH4* switch on the RF output adapter to the same channel you selected on the TV.
3. Place adapter's *VCR/TV* switch in *VCR*.
4. Place *POWER* in *CAMERA*. Power indicator will light.
5. Press the thumb trigger to begin recording. You can watch what the camcorder is seeing (or recording) on the TV screen.

Note: When the camcorder is used as a camera, turn the TV's volume down to prevent a high-pitched squeal caused by feedback.
6. Press the thumb trigger on the camcorder to pause recording.

Normal TV Viewing

For normal TV viewing, you may leave the RF output adapter hooked up to the TV. Disconnect the adapter's plug from

the camcorder and place the adapter's *VCR/TV* switch in *TV*.

Note to Cable TV Installer

This reminder is provided to call your attention to Article 820-40 of the National Electrical Code (Section 54 of Canadian Electrical Code, Part I), that provides guidelines for proper grounding and, in particular, specifies that the cable ground shall be connected to the grounding system of the building as close to the point of cable entry as practical.

Optional Accessories

We invite you to take a look at some great ideas for sparking creativity and adding to the fun of using your compact VHS camcorder. The following pages have a selection of accessories to help make your memorable moments look and sound even better.

These accessories are designed to make the process of recording and watching your videos more enjoyable.

To order accessories, contact your local Dealer.

If a dealer is not nearby, all accessories are available through toll-free ordering or by using the order form *on page 79*.

AC201A Soft Carrying Case

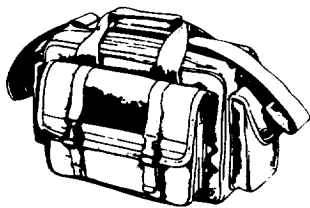

Custom compact soft case designed especially to provide protection and utility for your compact VHS camcorder and most accessories. Rugged fabric lined with soft non-abrasive material and generous padding. Has three outside pockets with storage for lens filters, adapters, batteries, and tapes.

DCC08 Car Cord Adapter

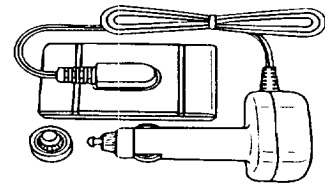

This car cord adapter enables you to operate your camcorder from your car, truck, or RV by plugging the car cord directly into the vehicle's cigarette lighter socket. The DCC08 is designed specifically to convert power from a 12-volt battery to a 6-volt output.

Cautions: The DCC08 is designed to be used only with vehicles having negative ground electrical systems.

Use only car cord adapter DCC08 with this camcorder. Use of any other car cord adapter may damage the camcorder and void your warranty.

Accessory Order Form

Order Form for Camcorder Model ProV800C

Description	Part No.	Price	Qty.	Total
Super Lightweight Tripod	AC088	\$ 39.95		
Soft Camcorder Case	AC201A	\$ 39.95		
Y-Adapter	AH25	\$ 2.95		
AC Battery Charger	CPS91	\$ 59.95		
Car Cord Adapter	DCC08	\$ 89.95		
Rechargeable Battery (Extended)	FB120	\$ 89.95		
Rechargeable Battery (Standard)	FB1260	\$ 49.95		
75-300 Cable Transformer	VH54	\$ 2.95		
Coaxial RF Cable	VH82	\$ 6.95		
Audio/Video Cable	VH83	\$ 5.95		
Coaxial RF Cable	VH90	\$ 7.95		
RF Output Adapter	ICVA147C	\$ 59.95		
Shoulder Strap	218858	\$ 12.95		
AC Adapter/Charger and DC Cable	236689	\$ 96.45		
	233087	\$ 27.80		
Cassette Adapter	237583	\$ 71.35		

Prices are subject to change without notice.

Total Merchandise.....\$ _____

Sales Tax.....\$ _____

We are required by law to collect the appropriate sales tax for each individual state, county, and locality to which the merchandise is being sent.

Shipping and Handling.....\$ **5.00**

Total Amount Enclosed.....\$ _____

Use VISA, MasterCard, or Discover.
Money order or check must be in U.S. currency only. No COD or cash.

Detach Here



Please complete other side also

Accessory Order Form

Charge your order on your VISA, MasterCard, or Discover Card by filling in below

USE YOUR CREDIT CARD



IMPORTANT: Copy complete account number from your VISA card

--	--	--	--	--	--	--	--	--	--	--	--	--	--	--	--	--	--	--	--	--

My card expires:

--	--

--	--



IMPORTANT: Copy complete account number from your MasterCard

--	--	--	--	--	--	--	--	--	--	--	--	--	--	--	--	--	--	--	--	--

Copy Number above your name on MasterCard

--	--	--	--	--

My card expires:

--	--

--	--



IMPORTANT: Copy complete account number from your Discover Card

--	--	--	--	--	--	--	--	--	--	--	--	--	--	--	--	--	--	--	--	--

My card expires:

--	--

--	--

AUTHORIZED SIGNATURE

Prices are subject to change without notice.

Print or type your name and address clearly. This will be your mailing label.



A complete and correct order will save you days of waiting.

Name: _____
Street: _____
_____ Apt: _____
City: _____
State: _____ Zip: _____

Please make sure that both sides of this form have been filled out completely.

- Allow 4 weeks for delivery.
- All accessories are subject to availability.

Detach Here 

Accessory Order Form

To order accessories, contact your local Dealer.

If a dealer is not nearby, you can also follow the directions below to order by telephone or direct-by-mail.

United States and Canada Orders

To place your order by phone, have your Visa, MasterCard, or Discover card ready and call the toll-free number listed below between 8AM and 8PM (EST) Monday through Friday or between 9AM and 5PM (EST) Saturday.

Use this number only to place an order for accessory items listed on this order form.

1 – 800 – 338 – 0376

To place your order by mail, detach and mail the completed order form with credit card information, money order, or check in U.S. currency (made payable to Thomson Consumer Electronics, Inc.) to the following address:

Video Accessories
PO Box 8419
Ronks, PA 17573

Care and Maintenance

Cleaning the Camcorder

To clean the camcorder's exterior, remove any power source connected to the camcorder and gently wipe it with a clean soft cloth.

Caution: Use of strong cleaning products, such as those containing alcohol or benzine, may damage the camcorder.

Cleaning the Camcorder's Lens

To clean the camcorder's lens, blow it with a blower brush, and then gently wipe the lens with a cleaning tissue and commercially prepared cleaning solution designed for use on camera lens. Improper cleaning may scratch the lens.

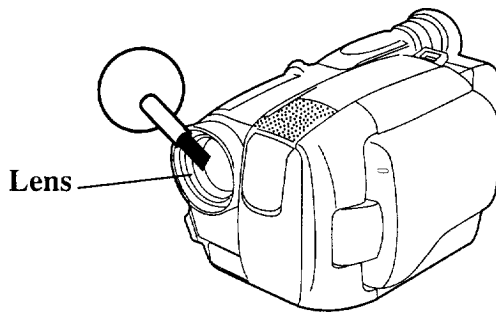

Caution: Do not touch the lens with your fingers. The oil from your skin can damage the lens.

Cleaning the Camcorder's LCD Monitor

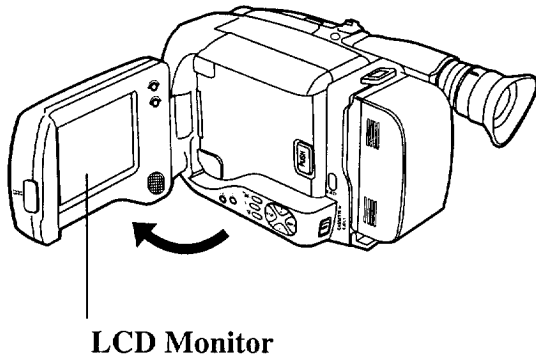

1. Press *PUSH/OPEN* and open the LCD monitor.
2. Carefully wipe the monitor with a clean soft cloth.
3. Close the monitor.

Cleaning the Camcorder's Viewfinder

The viewfinder eyepiece can be removed for cleaning.

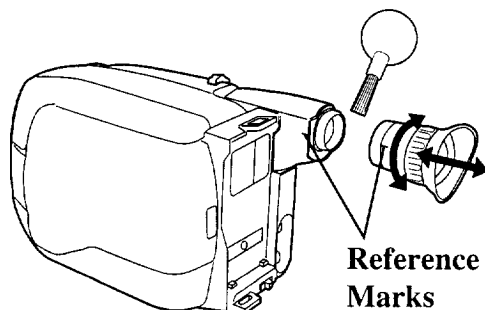

1. Turn the eyepiece counterclockwise and pull it out.
2. Remove dust using a blower brush.
3. Reattach the eyepiece by aligning the reference marks, and then turn the eyepiece clockwise until it clicks.

Care and Maintenance

Proper Care and Storage

- Keep dust and grit from entering the camcorder's cassette door. Dust and grit are abrasive and will cause excessive wear to both the camcorder's recording/playback heads and cassettes.
- Always close the lens cover and LCD monitor when the camcorder is not in use.
- Before handling your camcorder, make sure your hands and face are free from any chemical products such as suntan lotion, as it may damage the finish.
- The camcorder can be damaged by improper storage or handling. Do not subject the camcorder to swinging, shaking, or dropping.
- Do not store the camcorder in temperatures below -22°F (-30C) or above 149°F (65C).
- When the camcorder is not in use, always remove the cassette and AC adapter/charger or battery.
- Retain the original carton for future storage or shipping purposes.

Things to Avoid

- Do not attempt to disassemble your camcorder. There are no user-serviceable parts inside.
- Avoid operating your camcorder immediately after moving it from a cold location to a warm location. Give the camcorder 1-1/2 to 2 hours to reach a stable temperature before inserting a cassette. When the camcorder is moved from cold to warm, condensation may cause the tape to stick to the headwheel and damage the headwheel or tape.
- Do not aim your camcorder at the sun or other bright objects.
- Do not leave your camcorder in direct sunlight for extended periods of time. The resulting heat buildup could permanently damage the camcorder's internal parts.
- Do not operate the camcorder in extremely humid environments.
- Do not operate the camcorder near the ocean as salt water or salt water spray may damage the internal parts of the camcorder.
- Do not operate the camcorder for extended periods in temperatures below 40°F (4C) or above 95°F (35C).
- Do not expose the camcorder or adapter/charger to rain or moisture. If either component becomes wet, turn off the power and take the unit to an Authorized RCA Camcorder Servicer.
- Do not use an adapter/charger or batteries other than the ones specified for the camcorder. Use of the wrong accessories may cause damage to the camcorder.
- Do not operate the LCD monitor if the back becomes hot. Close and lock the monitor or turn off the camcorder to cool down the monitor.

Trouble Checks

Troubles sometimes are caused by simple “faults” that you can easily correct without the help of a service technician by first checking a few basic remedies.

Before you call or take your camcorder to an Authorized RCA Camcorder Servicenter, look below for the type of trouble you are experiencing. Then perform the simple checks and adjustments listed for that trouble.

If service should be necessary, the warranty information lists what your warranty covers and explains how to get service.

Trouble	Checks and Adjustments
No power	<ul style="list-style-type: none"> • Place the <i>POWER</i> switch in <i>CAMERA</i> or <i>VCR</i> to turn on the camcorder. The <i>POWER</i> indicator will light. • If using battery, it may need to be recharged. • If using AC adapter/charger, make sure it is plugged into a working outlet.
Won't record or playback	<ul style="list-style-type: none"> • If using AC adapter/charger, make sure it is plugged into a working outlet. • If the dew indicator (☐) flashes on the LCD monitor or in the viewfinder, there is moisture in the camcorder. Wait until the dew indicator no longer appears before operating the camcorder. • Make sure <i>POWER</i> switch is in correct position for desired operation. • There may not be a cassette in the camcorder. • Try ejecting and reinserting the cassette. • The cassette tape may be broken, try another cassette. • You may have reached the end of the cassette, try rewinding it.
Won't playback	<ul style="list-style-type: none"> • <i>POWER</i> switch must be in <i>VCR</i> position.
Won't record	<ul style="list-style-type: none"> • Safety tab has been removed. (See page 18.) • <i>POWER</i> switch must be in <i>CAMERA</i>.
No picture	<ul style="list-style-type: none"> • Open lens cover.
Camcorder turns itself off	<ul style="list-style-type: none"> • Place <i>POWER</i> switch to <i>OFF</i> and then in <i>CAMERA</i> or <i>VCR</i> to turn back on. If camcorder is left in record pause or play pause for several minutes, it will turn itself off to prevent tape wear.

Trouble Checks

Trouble	Checks and Adjustments
Tape stops during rewind or fast forward	<ul style="list-style-type: none"> • Time-counter memory may be on. Whenever an “M” appears with the time-counter display, the camcorder will stop rewinding (or fast forwarding) when counter reads <i>M 0:00:00</i>. Press <i>REW</i> or <i>FF</i> again to continue rewinding or fast forwarding, or press <i>COUNTER R/M</i> to turn off the memory-stop feature.
Camcorder remains in pause mode	<ul style="list-style-type: none"> • Press <i>PLAY/PAUSE</i> to return to normal playback.
Sound is too low or distorted	<ul style="list-style-type: none"> • Subject was too far from camcorder.
Dew indicator flashing in viewfinder or LCD monitor	<ul style="list-style-type: none"> • If the dew indicator (☒) flashes on the LCD monitor or in the viewfinder, there is moisture in the camcorder. Wait until this indicator no longer appears before operating the camcorder.
Poor auto-focus operation	<ul style="list-style-type: none"> • Subject is dark or behind glass. Auto-focus may not work under these conditions. Place the <i>FULL AUTO/PRESET</i> switch in <i>PRESET</i> and focus manually. See pages 36-37. • Subject is not in center of LCD monitor or viewfinder or two subjects are at different distances. Place <i>FULL AUTO/PRESET</i> switch in <i>PRESET</i> and focus manually. See pages 36-37. • Auto focus is automatically turned off when some effects are selected with the <i>FULL AUTO/PRESET</i> switch. Place <i>FULL AUTO/PRESET</i> switch in <i>FULL AUTO</i>. See page 32.
Vertical white lines appear when shooting bright object	<ul style="list-style-type: none"> • This may occur when background extremely contrasts with the subject.
Viewfinder or LCD monitor displays are dark or out of focus	<ul style="list-style-type: none"> • Lens is smudged, and image appears unfocused. • Eyepiece focus control is misadjusted. • Adjust <i>BRIGHT</i> control on LCD monitor.
Picture is too dark or subject too dark	<ul style="list-style-type: none"> • For best results, only use higher shutter speeds outdoors. Place the <i>FULL AUTO/PRESET</i> switch in <i>FULL AUTO</i>. • Add more light using the exposure control. See page 33.

(continued on next page)

Trouble Checks

Trouble	Checks and Adjustments
Colors do not look natural on recording	<ul style="list-style-type: none"> • Try adjusting white balance. <i>See pages 34-35.</i>
Picture recorded with special effect	<ul style="list-style-type: none"> • Program effect may be selected. Press <i>PROG.AE/EFFECT</i> to turn off the special effect. <i>See pages 62-63.</i>
Picture recorded in brown tone	<ul style="list-style-type: none"> • <i>Sepia</i> (■) selected with <i>PROG.AE/EFFECT</i>. Press <i>PROG.AE/EFFECT</i> to turn off <i>Sepia</i>. <i>See page 62-63.</i>
Picture recorded with black bars at top and bottom	<ul style="list-style-type: none"> • Camcorder is set to the <i>Cinema</i> mode. Press <i>PROG.AE/EFFECT</i> to turn off <i>Cinema</i>. <i>See pages 62-63.</i>
Title recorded on tape	<ul style="list-style-type: none"> • Title is recorded whenever it appears in viewfinder or on LCD monitor. Remove the title. <i>See pages 45-47.</i>
Date and/or time were recorded on tape	<ul style="list-style-type: none"> • Displays will be recorded on tape whenever they appear. Press <i>DISPLAY</i> to remove them from viewfinder when recording. <i>See pages 50-51.</i>
Date and/or time are incorrect	<ul style="list-style-type: none"> • Clock lithium cell battery may need replacing. <i>See page 48.</i> • Date or time may need to be set. <i>See page 49.</i>
No picture in viewfinder	<ul style="list-style-type: none"> • Viewfinder is automatically turned off when you open LCD monitor more than 60°. Close and lock LCD monitor to see picture in viewfinder.
No sound from built-in speaker during playback	<ul style="list-style-type: none"> • Speaker is automatically turned off when LCD monitor is not open more than 60°. Open LCD monitor. • Volume turned down. Adjust <i>SPEAKER VOLUME</i> control.
Tally light does not turn on during recording	<ul style="list-style-type: none"> • Turn the <i>Tally Light</i> feature on. <i>See page 53.</i>
Tape won't eject	<ul style="list-style-type: none"> • Battery too low. Recharge battery. • LCD monitor must be open at least 60°.

Trouble Checks

Trouble	Checks and Adjustments
Back of LCD monitor is hot	<ul style="list-style-type: none"> • Light used for monitor causes it to get hot. Close the monitor or turn off the unit to cool the monitor down.
Bright spots appear on monitor or areas of color are not clear	<ul style="list-style-type: none"> • Due to high-precision technology, black spots or bright spots may appear on LCD monitor. These are not recorded on the tape. • Pressing on the surface or edge of the monitor may cause blurring.
Error number (<i>E01</i> , <i>E02</i> , etc.) appears on LCD monitor or in viewfinder	<ul style="list-style-type: none"> • Try disconnecting power source. Wait ten seconds and then connect power source again. If error number does not disappear from viewfinder, consult your Authorized RCA Camcorder Servicer.
Battery runs down sooner than expected	<ul style="list-style-type: none"> • LCD monitor requires more battery power to operate than the viewfinder. • If camcorder has not been used for some time, charge the battery using the <i>REFRESH</i> feature on the adapter/charger. • Battery run times are measured when the camcorder is recording continuously. You can check your battery by first fully charging it and then aiming the camcorder at a clock and recording the picture of the clock. When the recording stops, play the last recorded section, and note the clock time. A one-hour battery should give you about 60 minutes of recording time. In practical use, you may not be able to record for the full time because the camera uses battery current when it is waiting between recordings (record-pause mode) and while you focus and zoom.

Specifications

General

Power requirement: 6VDC

Power consumption:

LCD Monitor off,

Viewfinder on: 5.7 watts

LCD Monitor on,

Viewfinder off: 7.5 watts

Weight: 2.3 lbs. (1,000g)

Dimensions – Including Viewfinder

4-15/16"(W) x 4-1/2"(H) x 9-1/16"(D)

124 (W) x 113(H) x 230(D) mm

Camera Section

Image Sensor: 1/4" CCD Imager

Lens: F1.2, (f = 4.1-57.4 mm)

Filter Diameter: 46 mm

Viewfinder

1/2" Black and White CRT

LCD Monitor

3" Diagonally Measured

LCD/TFT Active Matrix System

Tripod Mount

One 1/4" x 20 Threaded Hole

Video Recorder Section

Format: VHS-C

Record/Playback System:

Four Video Record/Playback Heads

One Flying Erase Head

Video Signal: EIA Standard NTSC

Color

Output: 1 Vp-p, 75 Ohms, Unbalanced

(via VIDEO Out Jack)

Audio Section

Output: -8dBs, 1 k-ohm (via AUDIO Out Jack)

Speaker: 20mm Round x 1, Monaural

AC Adapter/Charger

Power requirement: 100-240 V, 50/60 Hz.

Power consumption: 23 watts

Weight: .7 lbs. (320g)

Dimensions:

6"(W) x 1.7"(H) x 2.7"(D)

150 (W) x 42(H) x 68(D) mm

Information to User

This equipment has been tested and found to comply with the limits for a Class B digital device and RF lighting device pursuant to Part 15 and part 18 of the FCC Rules. These limits are designed to provide reasonable protection against harmful interference in a residential installation. This equipment generates, uses, and can radiate radio frequency energy and, if not installed and used in accordance with the instructions, may cause harmful interference to radio communications.

However, there is no guarantee that interference will not occur in a particular installation. If this equipment does cause harmful interference to radio or television reception, which can be determined by turning the equipment off and on, the user is encouraged to try to correct the interference by one or more of the following measures:

- Reorient or relocate the receiving antenna.
- Increase the separation between the equipment and receiver.
- Connect the equipment into an outlet on a circuit different from that to which the receiver is connected.
- Consult the dealer or an experienced radio/TV technician for help.

Alterations or modifications carried out without appropriate authorization may invalidate the user's FCC right to operate the equipment.

This Class B digital apparatus meets all requirements of the Canadian Interference — Causing Equipment Regulations.
Cet appareil numérique de la classe B respecte toutes les exigences du Règlement sur le matériel brouilleur du Canada.

You can reach Thomson at the following number:

800-283-6503

(Toll free inside U.S.A.)

Our toll-free Camcorder number operates from 8 a.m. to 5 p.m., CST Monday – Friday for U.S. customers only

Thomson provides a toll-free telephone number to help you with any problems you may encounter with your camcorder. Many can be diagnosed over the phone, and if necessary, a replacement unit can be shipped to you. Please have your camcorder model/serial number and date of purchase ready when you call. If your unit is out of warranty, we will quote the cost of an exchange unit to you.

Returning equipment to Thomson for repair or exchange

If we are unable to resolve your problem over the phone, we will gladly service your unit or exchange it for a new or, at our option, refurbished camcorder. Refer to the limited warranty to learn about your specific rights and responsibilities.

Always consult Thomson and get a Return Authorization number before returning anything! Obtain a Return Authorization (RA) number from the telephone representative before returning your equipment to avoid delays, accounting errors, or even loss of your unit.

Important information to customers who ship defective equipment to Thomson Consumer Electronics

The Thomson representative who authorized the return of your equipment will give you an RA number over the phone. They will also provide you with instructions on where and how to return your camcorder. Write the number in large, clear characters on the outside of the box to avoid confusion and misunderstandings. Shipments without an RA number clearly visible on the outside of the box will be returned to you at your expense.

Include a brief note describing the problem and any conversations about the problem you have had with Thomson personnel. Include your name, address

and model/serial number of your camcorder. These numbers are located on the bottom of your unit. If your camcorder is within the warranty period, please provide a copy of the bill of sale to verify purchase date. Use the original box and packing material to protect the equipment from damage in shipment.

For your protection, insure all shipments for full replacement value and use a reliable shipper. Thomson assumes no responsibility for warranty shipments from the customer to the factory if not shipped in the manner prescribed by Thomson.

Limited Warranty

What your warranty covers:

- Any defect in materials or workmanship.

For how long after your purchase:

- 90 days for labor charges.
- One year for parts.

(The warranty period for rental units begins with the first rental or 45 days from date of shipment to the rental firm, whichever comes first.)

What we will do:

During the initial 90 days

- Exchange your camcorder with a new or refurbished unit, or repair your camcorder. The option will be ours. There will be no cost to you.

After the 90 days and within one year

- Exchange your camcorder with a new or refurbished unit, or repair your camcorder. The option will be ours. Parts will be provided at no charge, but you will be responsible for the cost of labor required for the repair.

How you get service:

- Call 1-800-283-6503 and have your unit's date of purchase and model/serial number ready. The model/serial number information is on the bottom of your camcorder.
- A representative will troubleshoot your problem over the phone. If the representative determines that you should receive a replacement unit, you will be provided with a Return Authorization (RA) number and the location of a nearby exchange point if one exists. No returns will be accepted without the RA number.

To receive a replacement camcorder before you return yours:

If you are located near an exchange point:

1. We will send a replacement unit to the exchange point next business day delivery in the continental USA.
2. The exchange location will notify you of its arrival.

3. Take your unit, including all accessories, and your evidence of purchase date, such as a bill of sale, to the exchange location and you will be provided the new or refurbished unit.
4. If the repairs were covered by your warranty, you will not be billed.

If you are *not* located near an exchange point:

1. Provide your Discover, MasterCard or Visa account number and expiration date to our phone representative. This is for security purposes. If we receive your unit including all accessories within 14 days from the date you were provided an RA number, only items not covered by warranty will be charged to your account. **IF YOUR UNIT INCLUDING ALL ACCESSORIES IS NOT RECEIVED WITHIN 14 DAYS, THE SUGGESTED RETAIL VALUE OF THE CAMCORDER AND/OR ACCESSORIES WILL BE CHARGED TO YOUR CREDIT CARD.** This amount will be credited if the unit is subsequently received.
2. We will send you a replacement unit next business day delivery in the continental USA.
3. You will receive an invoice packed with the replacement product, but will not be charged for the unit portion of the invoice amount if we receive your unit including all accessories within 14 days from the date you were provided the RA number. Any labor and parts charges not covered by the warranty will be included and charged against your account.
4. Ship the unit back to us along with all accessories included with your camcorder using the replacement unit's carton. Shipping instructions will be included in the carton along with your RA number, which will allow you to easily ship the unit back

Limited Warranty

to us. **Make sure you insure your shipment in case of damage or loss.**

Include with the shipment:

- Evidence of purchase date, such as a bill of sale, to verify your unit's warranty eligibility.
- A brief note describing your camcorder's problem.
- Your name, address, and phone number.

Return transportation, storage, handling, and insurance costs are your sole responsibility. We accept no liability in case of damage or loss.

To receive a replacement unit after we have received your unit:

1. Write the RA number on the outside of the carton used to return the unit. **Make sure you insure your shipment in case of damage or loss.**
2. Carefully pack the unit along with all accessories included with your camcorder, using the original box and packing material if possible.
3. Include with the shipment:
 - Evidence of purchase date, such as a bill of sale, to verify your unit's warranty eligibility.
 - A brief note describing your camcorder's problem.
 - Your name, address, and phone number.

Return transportation, storage, handling, and insurance costs are your responsibility. We accept no liability in case of damage or loss.

4. Include a cashier's check or money order for payment if there are any out of warranty labor or parts charges which were indicated by the representative, and you elected not to use your credit card.
5. Upon receipt of your product, a new or refurbished unit will be shipped to you next day delivery in the continental USA.

To have your Camcorder repaired by an Authorized RCA Camcorder Servicenter:

- Check with your dealer or call 1-800-336-1900 for the Authorized RCA Camcorder Servicenter nearest you.
- Take your unit to the Authorized RCA Camcorder Servicenter of your choice.
- Show the Authorized RCA Camcorder Servicenter representative evidence of purchase date, such as a bill of sale.
- Pick up your camcorder when repairs are complete.

What your warranty *does not* cover:

- Adjustment of customer controls.
- Damage from misuse or neglect.
- A unit that has been modified or incorporated into other products or is used for institutional or other commercial purposes.
- Batteries for remote control and clock.
- Cleaning of video/audio heads.
- Camcorders purchased or serviced outside the USA.
- Return transportation, storage, and handling costs of your unit, including insurance for loss or damage.
- Acts of God, such as but not limited to lightning damage.

Product Registration:

- Please complete and mail the Product Registration Card packed with your camcorder. It will make it easier to contact you should it ever be necessary. The return of the card is not required for warranty coverage.

How State Law relates to warranty:

- This warranty gives you specific legal rights, and you may have other rights that vary from state to state.

If you purchased your camcorder outside the USA:

- This warranty does not apply. Contact your dealer for warranty information.

Index

- + ▲ and – ▼ Buttons11,20-21,33,40-47,49,52-59
- Accessories, Included3
- Accessories, Optional76-81
- Accessory, Order Form79-81
- Adapter/Charger, Using4,12
- Animation Indicators28,57
- Animation Recording56-57
- Assistance1,3,89,Back Cover
- Audio/Video Cable (Optional)72,78
- AUDIO/VIDEO Jacks10,72
- Auto Focus36
- Auto Head Cleaner30
- BATT. RELEASE Button10,13
- Battery Level Indicator15,26-27
- Battery Safety Precautions13
- Battery, Care and Storage15
- Battery, Using Rechargeable13-15
- Black Fader60-61
- Blue Fader60-61
- BRIGHT Control7,9,24,68
- Camcorder Lens, Cleaning82
- Camcorder, Cleaning82
- Camcorder, Powering12-16
- Camcorder, Turning On5
- Camcorder, Unpacking3
- Camera Edit Feature31
- CAMERA/OFF/VCR Switch5,8,10,13,15,16,20-23,29-31
 33,34,38,50,54,56,68,69,70,73
- Car Cord Adapter, Optional16,76
- Care and Maintenance82-83
- Care and Storage of Battery15
- Cassette Adapter66-67
- Cassette Adapter, Install Battery66
- Cassette Door5,19
- Cassette Warning Indicator28-29
- Cassettes, Care and Storage19
- Cassettes, Inserting and Removing19
- CautionsInside Front Cover
- Change Indicator26-27
- Charging the Battery14
- Checking Problems84-87
- Cinema Feature62-63
- Cleaning Camcorder82
- Clock Cell Compartment10,48
- Clock Cell Warning28-29,48
- Clock Cell, Installing48
- Color Filter43
- Contents1-2
- Controls, Camcorder9-11
- Copying Tapes72-73
- COUNTER R/M Button70,73
- Customer Assistance1,3,89,Back Cover
- Date and Time Display26-27,48-49
- Date and Time, Record on Tape50-51
- Date and Time, Set49
- DC IN Jack, Camcorder4,10,12
- Design Specifications88
- Dew Warning Indicator28
- Digital Zooming39
- DISPLAY Button11,50-51
- Displays, Viewfinder and LCD Monitor26-29
- EDIT SEARCH + and – Buttons11,22-23,31
- EIS (Electronic Image Stabilizer) Button11,38
- EIS Indicator28,38
- EJECT Button5,9,19,20-21,68
- Electronic Image Stabilizer38
- Electronic Indexing32
- Erase Protection18
- Exposure Control33
- Exposure Indicator28-29
- Eyepiece Focus Control7,9,20-21,25,68
- Fade and Wipe Indicators26-27,60-61
- FADE/WIPE Button11,22-23,27,60-61
- Fading In and Out60-61
- FAR ◀ and NEAR ▶ Buttons11,29,36-37,40-47,49,52-59
- FF Button11,31,69
- First-Time Operation3-11
- Flying Erase Head30
- Focus Indicators28-29,36-37
- Focus Lock Feature37
- Focusing36-37
- Full Auto Mode6,32
- FULL AUTO/PRESET Switch6,9,20-21,26
 29,32-37,40-47,49,52,54,56,58,60-63
- Gain Up Feature42
- Hand Strap4,10
- High Shutter Speed Feature62-63
- Included Accessories3
- INDEX Indicator28-29,32
- Information to User88
- Inserting and Removing Cassettes19
- Installing Clock Cell48
- JLIP ID No.53
- LCD Monitor7,9,19,20-21,24,26-29,68,82
- LCD Monitor or Viewfinder Playback68
- Lens9,82
- Lens, Cleaning82
- LENS COVER Control4,10,20-21,22-23
- LENS COVER Indicator26-27
- Limited Warranty90-91
- Maintenance and Care82-83
- Making a Recording20-23
- MAN.W.BAL Button11,34-35
- Manual Focus37
- Manual Focus Indicators28-29,36-37
- Memory-Stop Feature70
- MENU Button11,20-21,40-47,49,52-59
- Microphone9,30
- Mosaic Fader60-61
- NEAR ▶ and FAR ◀ Buttons11,29,36-37,40-47,49,52-59
- Operation, First-Time3-11

Index

Optical Zooming	39
Optional Accessories	76-81
Order Form, Accessory	79-81
PAUSE Indicator	5,8,21,26,32,33
Pause, Stop-Action	69
PLAY/PAUSE Button	8,11,69,73,75
Playback	66-75
Playback Features	69-71
Playback on a TV With <i>AUDIO/VIDEO IN</i>	
Jacks	72-73
Playback on a TV Without Audio/Video	
Inputs	74-75
Playback Speeds	18
Playback, First	8
Playback, Viewfinder or LCD Monitor	68
Plug Adapter (Optional)	12
<i>POWER (CAMERA/OFF/VCR)</i> Switch	
.....	5,8,10,13,15,16,20-23,29,31
.....	33,34,38,50,54,56,68,69,70,73
Powering the Camcorder	12-16
Problem Solving	84-87
Product Registration	Inside Front Cover
Production Effects Indicators	26,62-63
<i>PROG.AE/EFFECT</i> Button	11,22-23,26,62-63
Proper Care and Storage	83
<i>PUSH</i> Button	5,9,19,20-21,68
<i>PUSH/OPEN</i> Button	5,7,9,19,20-21,24,68
<i>QUICK REC</i> Button	10,30
Quick Record Feature	30
Quick Review Feature	31
<i>REC</i> ►►► Indicator	8,26
Recording Menu	40-46,49,52
Recording Menu – Sub Menu	52-59
Recording Speed	6,18
Recording Tips	17
Recording, First	8
Recording, Making	20-23
Refreshing the Battery	14
Registration Card	Inside Front Cover
<i>REW</i> Button	8,11,31,69,70
<i>RF DC OUT</i> Jack	10,74
RF Output Adapter, Optional	74-75,78
Safety Tab	18
Searching, Visual	69
Self-Timer Feature	54-55
Self-Timer Indicator	28,54-55
Sepia Feature	62-63
Set the Date and Time	49
Shoulder Strap Attachment Rings	10,64
Shoulder Strap, Attaching	64
Shutter Wipe	60-61
Slide Wipe	60-61
Solving Problems	84-87
<i>SPEAKER VOLUME</i> Control	9,68
Specifications	88
Speeds, Recording and Playback	6,18
Sports Feature	62-63
<i>SP•EP</i> Switch	6,11,18,20-21,26,44
Status Displays	26
<i>STOP</i> Button	8,11,31,68,69,73,75
Stop-Action Pause	69
Sub Menu of Recording Menu	52-59
Table of Contents	1-2
Tally Light	8,22-23,30,53
Tally Light Feature	53
Tape Copying	72-73
<i>TAPE END</i> Warning	28-29, 44
Tape Length Indicator	28-29
Tape Positioning	31,69
Tape Speed Indicators	18,26
Tape Time-Remaining Display	28,44
Tape Wheel	5,19
Tape Window	5,19
Tele Macro Zooming Feature	41
Things to Avoid	83
Thumb Trigger	8,10,23
Tilt, LCD Monitor	24
Tilt, Viewfinder	25
Time and Date Display	48-49
Time and Date, Record on Tape	50-51
Time and Date, Set	49
Time Counter	28-29,70
Time-Lapse Indicators	28,59
Time-Lapse Recording	58-59
Time-Remaining Display	28,44
Tips, Recording	17
Tips, Traveling	65
Title Display	26-27
Title, Creating	46
Titles, Preset	45
Tracking	71
<i>TRACKING</i> Buttons	11,71
Traveling Tips	65
Tripod, Using	77
Trouble Checks	84-87
Turning On the Camcorder	5
Twilight Feature	62-63
Unpacking the Camcorder	3
User Information	88
Using Cassette Adapter	66-67
Video Cassettes	18-19
Viewfinder	7,9,20-21,25,26-29,68,82
Viewfinder Displays	26-29
Viewfinder or LCD Monitor Playback	68
Viewfinder, Cleaning	82
Visual Searching	69
Warranty, Limited	90-91
White Balance	34
White Balance Indicators	28-29,34-35
Wipe and Fade Indicators	26-27,60-61
Wiping In and Out	60-61
Zoom Indicator	26-27,39
Zoom Lever	10,22-23,27,39
Zooming	39

Need Assistance? We want to help!

U.S. Consumers:

Customer Service800-336-1900
Accessories800-338-0376

Canadian Consumers:

English800-522-0338
French800-522-0445

If your camcorder needs service, please contact your dealer or the nearest Servicenter from the yellow pages. Please do not send any products to the Indianapolis address listed in this manual or on the carton. This will only add delays in service for your product.

 **THOMSON CONSUMER ELECTRONICS**
10330 N Meridian Street
Indianapolis, IN 46290

©1996 Thomson Consumer Electronics, Inc.
Trademark(s)[®] Registered
Marca(s) Registrada(s)
Printed in Japan
Part Number 96-ProV800C-1