

M-01-02-252

# *Video Cassette Recorder*

*Operating Instructions*

SLV-750HF/751HF

**VHS** Hi-Fi

# WARNING

To prevent fire or shock hazard, do not expose the unit to rain or moisture.

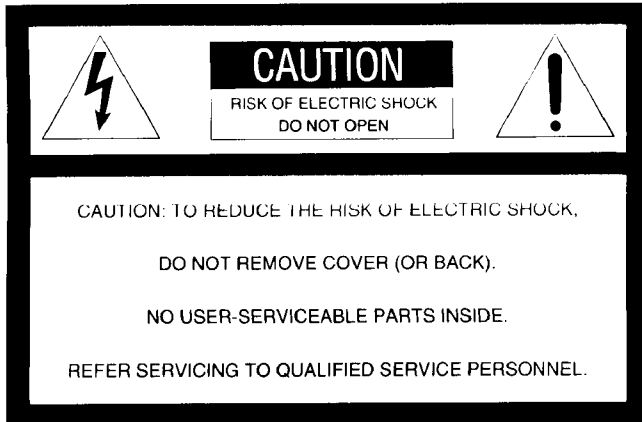

This symbol is intended to alert the user to the presence of uninsulated "dangerous voltage" within the product's enclosure that may be of sufficient magnitude to constitute a risk of electric shock to persons.



This symbol is intended to alert the user to the presence of important operating and maintenance (servicing) instructions in the literature accompanying the appliance.

# Owner's Record

The model number is located at the rear and front of the unit and the serial number on the top. Record the serial number in the space provided below. Refer to these numbers whenever you call upon your Sony service dealer regarding this product.

Model No. SLV-750HF Serial No. \_\_\_\_\_

Model No. SLV-751HF Serial No. \_\_\_\_\_

## For the Customers in the U.S.A.

### WARNING

This equipment has been tested and found to comply with the limits for a Class B digital device, pursuant to Part 15 of the FCC Rules. These limits are designed to provide reasonable protection against harmful interference in a residential installation. This equipment generates, uses, and can radiate radio frequency energy and, if not installed in accordance with the instructions, may cause harmful interference to radio communications. However, there is no guarantee that interference will not occur in a particular installation. If this equipment does cause harmful interference to radio or television reception, which can be determined by turning the equipment off and on, the user is encouraged to try to correct the interference by one or more of the following measures:

- Reorient or relocate the receiving antenna.
- Increase the separation between the equipment and receiver.
- Connect the equipment into an outlet on a circuit different from that to which the receiver is connected.
- Consult the dealer or an experienced radio/TV technician for help.

You are cautioned that any changes or modifications not expressly approved in this manual could void your authority to operate this equipment.

### Caution

TO PREVENT ELECTRIC SHOCK, DO NOT USE THIS POLARIZED AC PLUG WITH AN EXTENSION CORD, RECEPTACLE OR OTHER OUTLET UNLESS THE BLADES CAN BE FULLY INSERTED TO PREVENT BLADE EXPOSURE.

### NOTE TO CATV SYSTEM INSTALLERS IN THE U.S.A.:

This reminder is provided to call the cable TV system installer's attention to Article 820-40 of the NEC that provides guidelines for proper grounding and, in particular, specifies that the cable ground shall be connected to the grounding system in the building, as close to the point of cable entry as practical.

# Table of Contents

## Table of Contents

### Preliminaries

<b>WARNING</b> .....	2
<b>Owner's Record</b> .....	2
For Customers in the U.S.A. ....	2
<b>Precautions</b> .....	4
Safety .....	4
Installation .....	4
Operation .....	4
Cleaning .....	4
<b>Introduction</b> .....	5
How to Use This Manual .....	5
Overview .....	5

### Preparation

<b>Hookups and Getting Started</b> .....	6
<b>Hookup 1</b>	
Audio/Video (A/V) Hookup .....	7
<b>Hookup 2</b>	
Cable Hookup .....	8
VCR Setup .....	9
VCR Plus+ Channel Setup .....	9
<b>Hookup 3</b>	
Cable Hookup .....	10
VCR Setup .....	11
VCR Plus+ Channel Setup .....	11
<b>Hookup 4</b>	
Cable Hookup .....	12
VCR Setup .....	13
VCR Plus+ Channel Setup .....	13
<b>Hookup 5</b>	
Antenna Hookup .....	14
VCR Setup .....	15
VCR Plus+ Channel Setup .....	15
<b>Preparing the Remote Commander</b> .....	16
Inserting Batteries .....	16
Operating the VCR with the Remote Commander .....	16
How to use the Remote Commander .....	16
<b>Setting the Time and Date</b> .....	17
Example of Time and Date Setting .....	17
<b>Presetting the Active Channels</b> .....	19
Presetting All Receivable Channels Automatically .....	19
Presetting Desired Channels or Disabling Unwanted Channels .....	20
Fine-tuning .....	21
Cable TV Channel Assignment .....	21
<b>Activating the Cable Box Control Function</b> .....	22
Setting the Cable Box Control .....	23
Checking the Cable Box Control Setting .....	24
<b>Using the SETUP MENU</b> .....	25
Menu Choices .....	26

### Basic Operations

<b>Playback</b> .....	27
Inserting a Video Cassette .....	27
Playback .....	28

The Display .....	29
Indexing Tape Contents .....	29
Playing Back Externally-Recorded Tapes .....	30
Selecting the Monitor Sound .....	30
Listening to Mixed Hi-Fi and Normal Track Sound .....	31
<b>Recording TV Programs</b> .....	32
Recording TV Programs .....	32
Pausing .....	33
Recording with the TV Off .....	34
Watching One TV Program While Recording Another .....	34
Recording Multi-Channel TV Sound (MTS) .....	34
<b>Timer Recording</b> .....	35
Setting the Timer .....	35
Overlapping Timer Recordings .....	38
Checking the Timer Settings .....	39
Changing or Cancelling the Timer Settings .....	40
Using the VCR Before Timer Recording Starts .....	41
<b>Introducing VCR Plus+</b> .....	42
VCR Plus+ Setup Instructions .....	42
Recording Programs Using VCR Plus+ .....	44

### Advanced Operations

<b>Variable Speed Playback</b> .....	46
Variable Speed Playback .....	46
Still Picture .....	46
Picture Search .....	46
Locked Picture Search .....	47
Skip Playback .....	47
Slow Motion Playback .....	47
Frame-by-Frame Picture .....	47
Picture Adjustment During Variable Speed Playback .....	47
<b>Index Function</b> .....	48
Index Signals .....	48
Playing Back from the Index Point - Index Scan .....	49
Locating an Index - Index Search .....	50
<b>APC (Adaptive Picture Control)</b> .....	51
Using the APC Function when Recording .....	51
Using the APC Function when Playing Back a Tape .....	51
<b>Quick-Timer Recording</b> .....	52
Quick-Timer Recording .....	52
<b>Editing</b> .....	53
Editing from Another VCR .....	53
Editing onto Another VCR .....	54

### Additional Information

<b>General Setup Information</b> .....	55
Setting the RF UNIT .....	55
Attaching the External Antenna Connector (supplied) .....	56
Attaching the EAC66 U/V Band Separator / Mixer (not supplied) .....	56
<b>Identifying the Parts and Controls</b> .....	57
Front Panel .....	57
Rear Panel .....	58
Display Window Indicators .....	59
Remote Commander .....	60
<b>Troubleshooting</b> .....	61
<b>Specifications</b> .....	63
<b>Index</b> .....	64

# Precautions

## Safety

- Operate the unit only on 120 V AC, 60 Hz.
- If anything falls into the cabinet, unplug the unit and have it checked by qualified personnel before operating it any further.
- One blade of the plug is wider than the other for the purposes of safety and will fit into the power outlet only one way. If you are unable to insert the plug fully into the outlet, contact your dealer.
- Unplug the unit from the wall outlet if you do not intend to use it for an extended period of time. To disconnect the cord, pull it out by the plug, never by the cord.

## Installation

- Allow adequate air circulation to prevent internal heat buildup.
- Do not place the unit on surfaces (rugs, blankets, etc.) or near materials (curtains, draperies) that may block the ventilation slots.
- Do not install the unit near heat sources such as radiators or air ducts, or in a place subject to direct sunlight, excessive dust, mechanical vibration or shock.
- Do not install the unit in an inclined position. It is designed to be operated in a horizontal position only.
- Keep the unit and cassettes away from equipment with strong magnets, such as microwave ovens or large loudspeakers.
- Do not place heavy objects on the unit.

## Operation

- When the unit is not in use, turn the power off to conserve energy and to extend its life.
- Remove and store video cassettes after recording or playback.

## Cleaning

- Clean the cabinet, panel and controls with a dry, soft cloth, or a soft cloth slightly moistened with a mild detergent solution.
- Do not use any type of solvent, such as alcohol or benzene.

## How to Use This Manual

This manual includes information on two video cassette recorder (VCR) models, the SLV-750HF and the SLV-751HF. The model name is indicated on the rear and front panels.

This manual is divided into five chapters.

The chapters and their contents are as follows:

- Preliminaries** (page 2)
- Preparation** (page 6)
- Basic Operations** (page 27)
- Advanced Operations** (page 46)
- Additional Information** (page 55)

If you are using your VCR for the first time, start from the section "**Hookups and Getting Started**" (page 6). This section explains how to hookup, set up, and operate your VCR so that you can start enjoying it right away.

For information about the VCR's basic operations, such as Playback (page 27), Recording TV Programs (page 32), or Timer Recording (page 35), see **Basic Operations**.

If you are already familiar with the basic operations, see **Advanced Operations**.

If you have any problems in operating the VCR, refer to **Troubleshooting**. If your VCR is in need of repair, contact your nearest Sony Service Center facility.

## Conventions of this manual

This manual explains operations using the VCR Remote Commander. However, the buttons on the VCR with the same name or mark as those on the Remote Commander function exactly the same as those on the Remote Commander.

When you are reading through the manual, remember:

- Buttons and switches are shown in uppercase letters.  
Example: Press ► PLAY.
- Numbers in the illustrations correspond to numbers in the text.
- ▲ indicates signal flow.
- Notes and cautions are enclosed in boxes.

## Unpacking

Check that you have received the following accessories:

- Remote Commander (1)
- Size AA (R6) batteries (2)
- External antenna connector (1)
- 75-ohm coaxial cable with F-type connectors (1)
- AC power cord (1)
- Audio/video connecting cable (3 phono to 3 phono) (1)
- Cable Mouse (Cable Box Controller) (1)

## Overview

### Functions

- VCR Plus+™ system**  
Allows you to quickly and easily preset up to eight TV programs.
- Cable box control**  
Allows your VCR to control channel selection on most cable boxes.
- APC (Adaptive Picture Control) function**  
Automatically optimizes recording and playback performance by adjusting the video circuitry for each tape that you use.
- Auto tracking function**  
Automatically adjusts the tracking condition for optimum picture quality.
- Timer recordings of eight programs in a month**  
Recording of up to eight TV programs can be preset up to one month in advance.
- DUAL MODE SHUTTLE ring**  
Allows quick access to the desired scene and playback in various speeds in forward and reverse directions.
- Input connectors on the front panel**  
Allows easy connection to a video camera recorder.
- Index function**  
The beginning of a desired scene can be located easily with the index search function.
- Auto head cleaner**  
Cleans the video heads each time a cassette is inserted or ejected.

### On-screen display

- ON SCREEN HELP message**  
The VCR gives a message on screen with a beep tone to warn that you have attempted an incorrect operation.
- DISPLAY**  
Tape counter, cassette speed, operation mode, and remaining cassette length can be displayed on the TV screen.
- TIMER SET/CHECK display**  
Timer recording settings can be set and checked by referring to the TV screen.
- LANGUAGE (Canadian versions only)**  
You can preset your VCR to display screen information in either English or French.

### High-quality picture

- High-quality picture**  
Your Sony VCR provides sharp, finely detailed pictures through High Quality (HQ) picture technology. Your VCR incorporates VHS high-quality picture technology and is compatible with any VCR bearing the **VHS** mark.

VCR Plus+ and PlusCode are trademarks of Gemstar Development Corp.

# Hookups and Getting Started

Before you can use your VCR for the first time, you need to connect it to your TV and set it up to receive programs for viewing and recording. This section explains how to hook up, set up, and operate your VCR so that you can start enjoying it right away. There are, however, many types of TVs available and many different ways in which your TV can be hooked up. As a result, this manual describes several ways your VCR can be connected.

To hook up your VCR so that it works best for you, first scan through the table below. Then use the accompanying diagrams and procedures on the following pages to complete your VCR's connections.

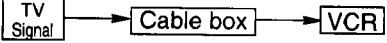
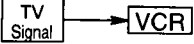
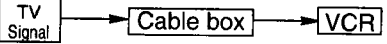
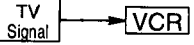
<u>If You ...</u>	<u>Use</u>	<u>Refer to...</u>
Have Audio/Video Inputs on your TV.	Hookup 1 first, then proceed.	Page 7
Have a cable box.	Hookup 2. 	Page 8
Have cable, but do not have a cable box.	Hookup 3. 	Page 10
Have a cable box that cannot be controlled by the VCR's cable box control feature.	Hookup 3 or 4, (or contact your cable company. They may be able to supply a compatible cable box.) 	Page 10 or 12
Have an antenna, not cable TV.	Hookup 5. 	Page 14

After you've completed the connections, follow the instructions for setup, including VCR Plus+ setup. (During setup, if you need more details of the procedures described, page numbers are provided where you can find complete, step-by-step instructions.)

After you've completed the setup, you're ready to use your VCR. Follow the instructions provided in "To Watch the TV," "To Watch the VCR," and "To Record A Program" for your specific hookup. (Again, if you need step-by-step instructions, page numbers are provided where you can find this information.)

### Caution

Connections between the VCR VHF/UHF OUT connector and the antenna terminals of a TV receiver should be made only as shown in the instructions. Failure to do so may result in operation that violates the regulations of the Federal Communications Commission regarding the use and operation of RF devices. Never connect the output of the recorder to an antenna or make simultaneous (parallel) antenna and recorder connections at the antenna terminals of your receiver.

Before making the connections, check the following points:

- Turn off the power to the VCR and TV.
- Do not connect the AC power cords until all of the connections are completed.

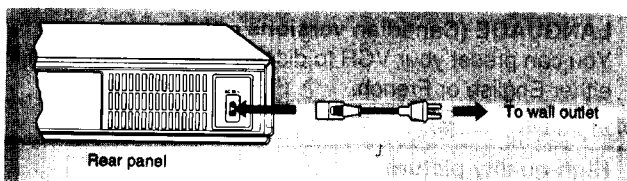

- Make connections firmly. Loose connections may cause picture distortion.
- If your TV doesn't match any of the examples provided, consult your nearest Sony dealer or qualified technician.

# Hookup 1

## Audio/Video (A/V) Hookup

If your TV has audio/video (A/V) input jacks, you will get better picture and sound if you hook up your VCR using these connections. In addition, for a true "home theater" experience, you should connect the audio outputs of your VCR or TV to your stereo system.

If your TV doesn't have A/V inputs, see the following pages for antenna or cable hookup.

If you intend to use the VCR for playback only, you're finished after you've made these connections. If you want to record off-air or off your cable TV system, please do the A/V hookup on this page first, then proceed to the following pages for antenna or cable hookup.

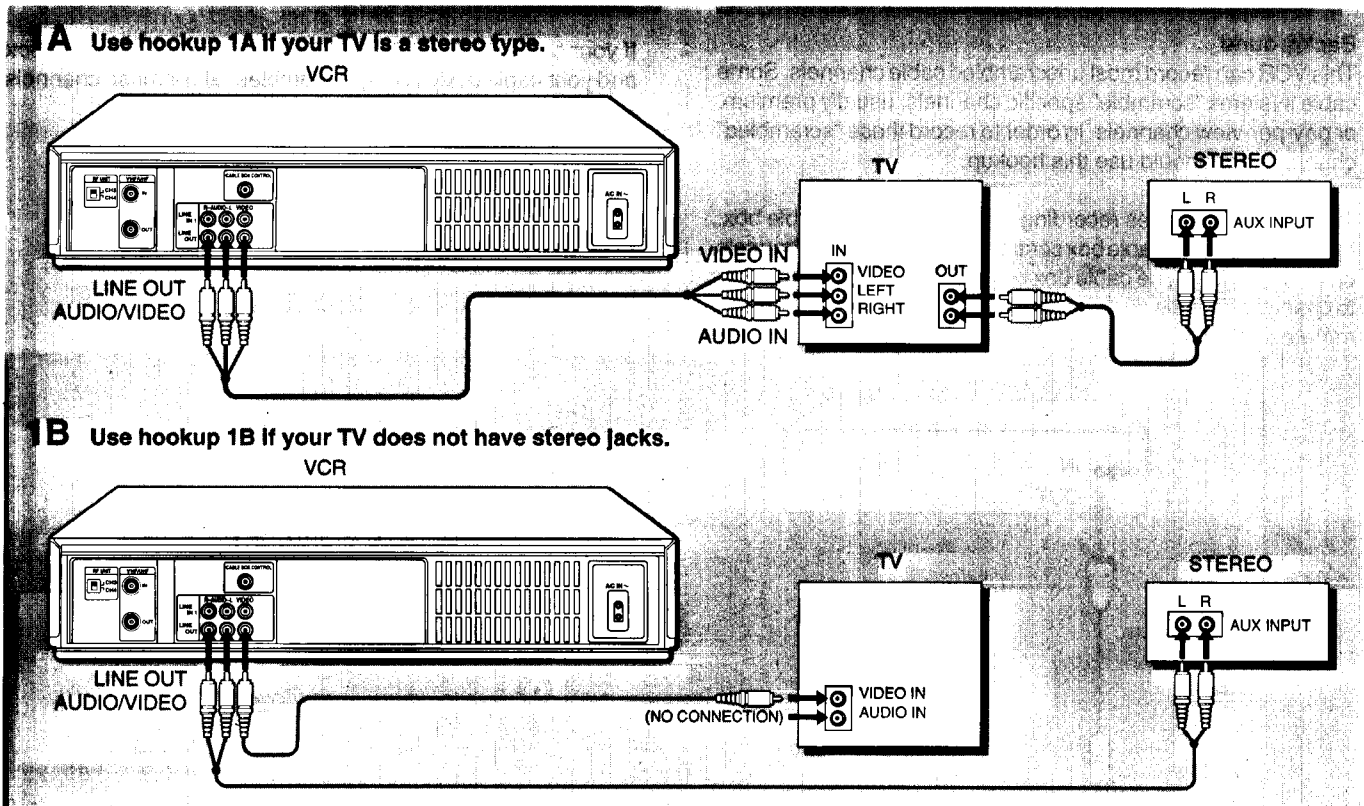

After you've hooked up your TV using the A/V connections, use the following procedure to set up and use the VCR with your TV.

### A/V Setup & Operation

Set AUTO ANT SEL to OFF.

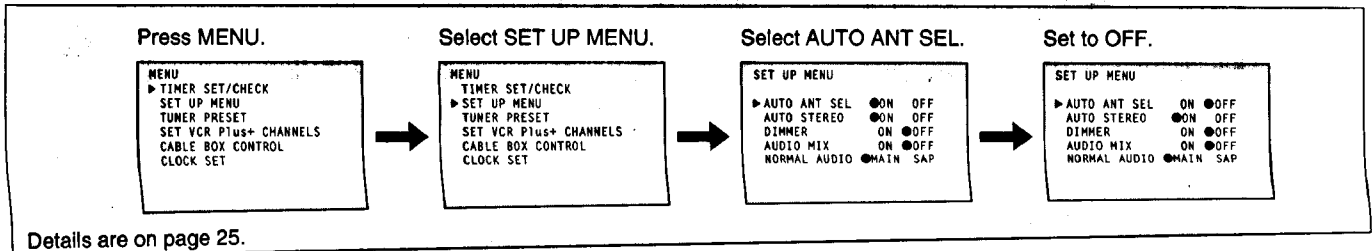

## Hookup 2 - Using VCR Cable Box Control

### Cable Hookup

#### Recommended Use:

This hookup is recommended for most cable systems. It allows the VCR's cable box control feature to control the channel on the cable box, simplifying the recording process. You should use this hookup if you have a cable box, especially if your cable company "scrambles" all, or most, channels.

#### Background

This VCR can record most unscrambled cable channels. Some cable systems "scramble" specific channels, usually premium, or pay-per-view channels. In order to record these "scrambled" channels you should use this hookup.

This hookup simplifies recording channels from the cable box, by using the VCR's cable box control feature to change channels on the cable box. The cable box control feature allows the VCR to change channels on most cable boxes that are capable of IR remote control.

A list of compatible cable boxes is on page 24. If, after checking your setup, you are sure that the VCR will not control your cable box, contact your cable company. They may be able to supply a compatible cable box.

If your cable company cannot supply a compatible cable box, and your cable system only "scrambles" a few channels, use Hookup 3.

If your cable company cannot supply a compatible cable box, and your cable system only "scrambles" all, or most, channels, you must use Hookup 4.

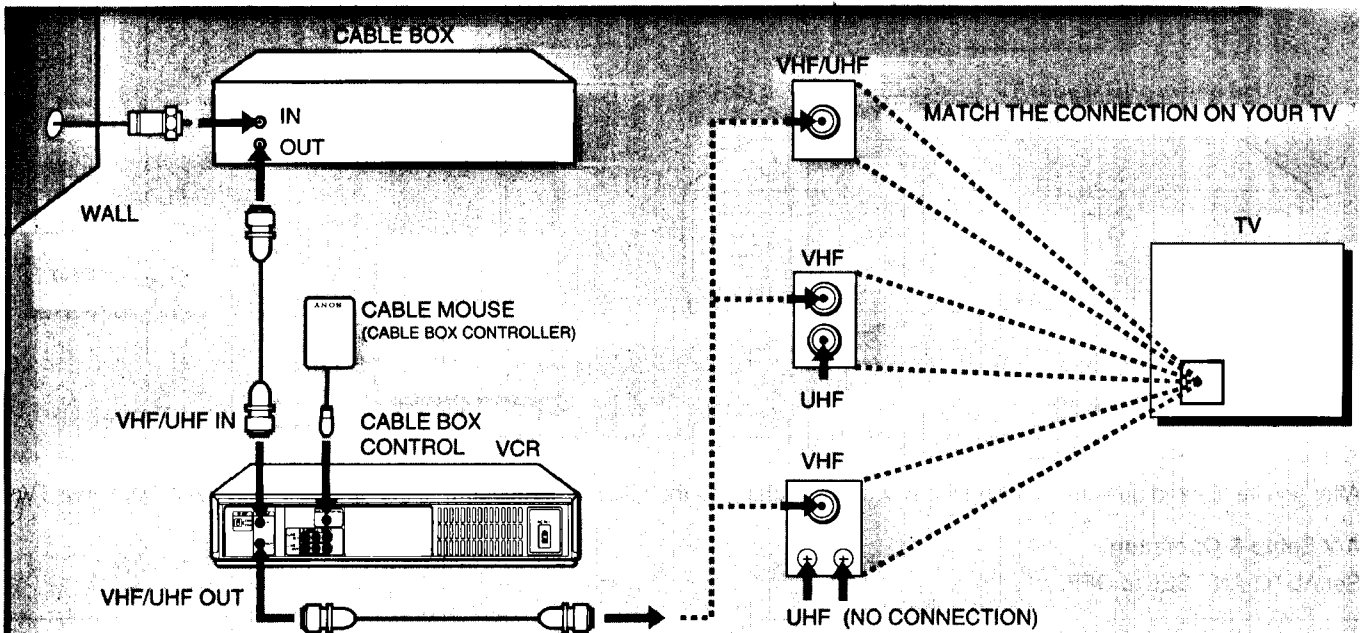

### Cable Mouse Hookup

Position the CABLE MOUSE on the cable box as shown below. Make sure that the front of the CABLE MOUSE projects out in front of the cable box. Remove the protective film from the double-sided tape to stick the CABLE MOUSE to the cable box.

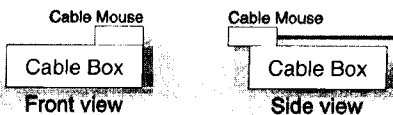

For best results, position the cable box away from the VCR.

### What You Can and Can't Do With This Hookup

#### What You Can Do

- Record any channel by selecting the channel on the cable box from your VCR.

#### What You Can't Do

- Record with the cable box turned off.
- Record one channel while watching another channel.



## VCR Setup

- 1 Set the RF UNIT on the VCR's rear panel to CH 3 or CH 4.  
If you made A/V connections, skip this step.

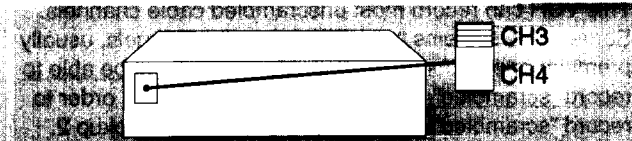

Set to whichever channel is not used in your area.  
If both are used, pick either channel.

Details are on page 55.

- 2 Switch on your cable box.
- 3 Set NORMAL/CATV to CATV.

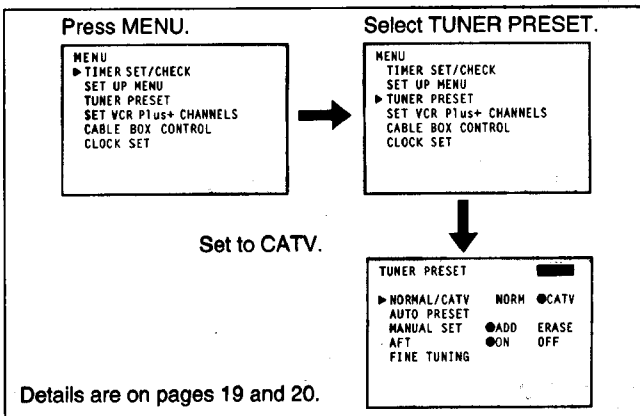

- 4 Set the CABLE BOX CONTROL to ON.

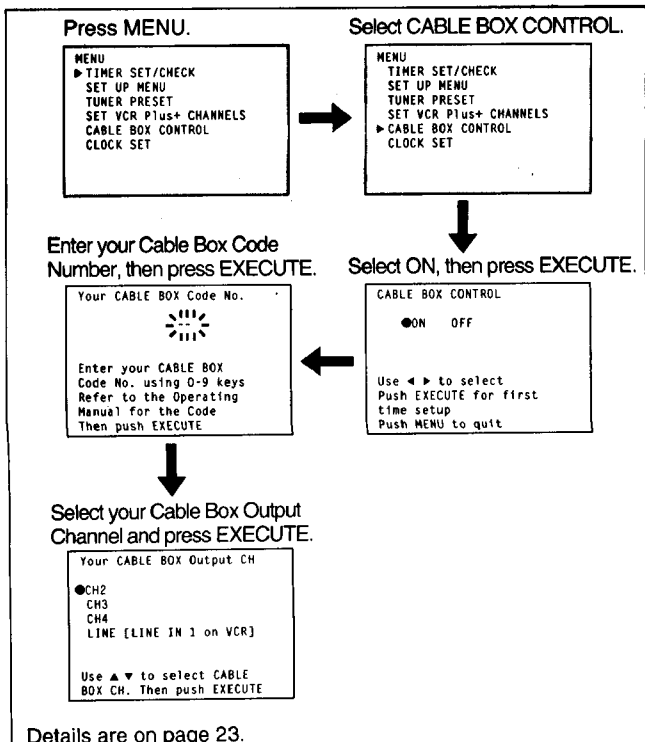

## VCR Plus+ Channel Setup

- 1 Find the VCR Plus+ Channel Listing in your program guide. For details, see page 42.
- 2 If the channels in the program guide are different from the channels that you actually use on your TV, set the channels that are different as follows:

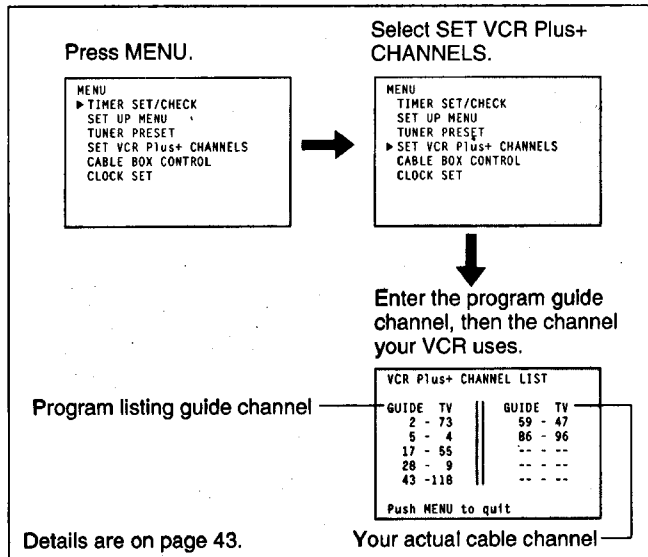

### To Watch the TV

- 1 Turn your VCR off, or press the VCR's TV/VTR button until the VTR indicator in the display window goes off.
- 2 Switch on your cable box.
- 3 Tune the TV to the cable box output channel (usually 2, 3, or 4).
- 4 Select the channel that you want to watch with your cable box.

### To Watch the VCR

- 1 Tune the TV to CH 3 or CH 4, (or to A/V input if you made A/V connections.)

- 2 Insert a cassette and press ► PLAY.

Details are on page 28.

### To Record A Program

- 1 Switch on the cable box.
- 2 Press VCR Plus+ on the Remote Commander.
- 3 Enter the program's PlusCode number.
- 4 Press ONCE, DAILY, or WEEKLY on the Remote Commander.
- 5 Insert a blank cassette.
- 6 Press TIMER REC on the Remote Commander.
- 7 Leave the cable box on.

Details are on page 44.

## Hookup 3 - No Cable Box or Incompatible Cable Box, Few "Scrambled" Channels

### Cable Hookup

#### Recommended Use:

Use this hookup if you do not have a cable box.

Also use this hookup if your cable company cannot supply a cable box that is compatible with the VCR's cable box control feature, and your cable system only "scrambles" a few channels.

#### Background

This VCR can record most unscrambled cable channels. Some cable systems "scramble" specific channels, usually premium or pay-per-view channels. You will not be able to record "scrambled" channels with this hookup. In order to record "scrambled" channels you should use Hookup 2.

The "Cable Mouse" is not used in this hookup.

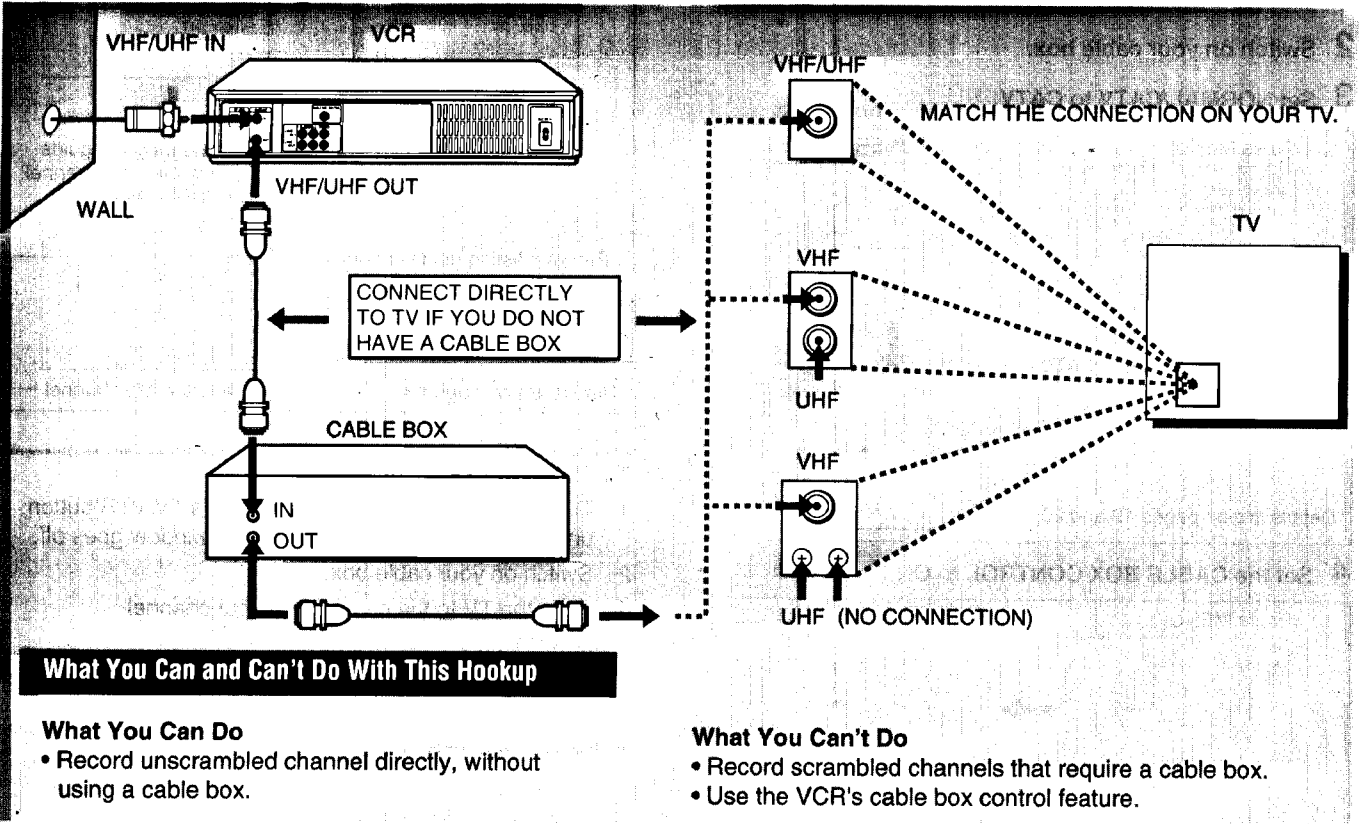

#### What You Can and Can't Do With This Hookup

##### What You Can Do

- Record unscrambled channel directly, without using a cable box.

##### What You Can't Do

- Record scrambled channels that require a cable box.
- Use the VCR's cable box control feature.

## VCR Setup

- 1 Set the RF UNIT on the VCR's rear panel to CH 3 or CH 4.  
If you made A/V connections, skip this step.

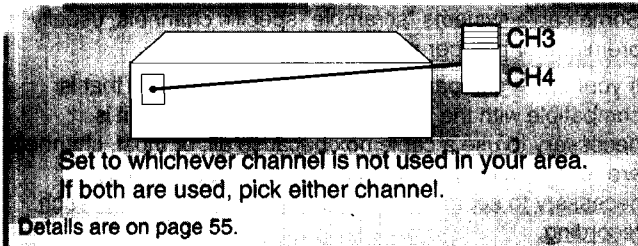

- 2 Set CABLE BOX CONTROL to OFF.
- 3 Set NORMAL/CATV to CATV.

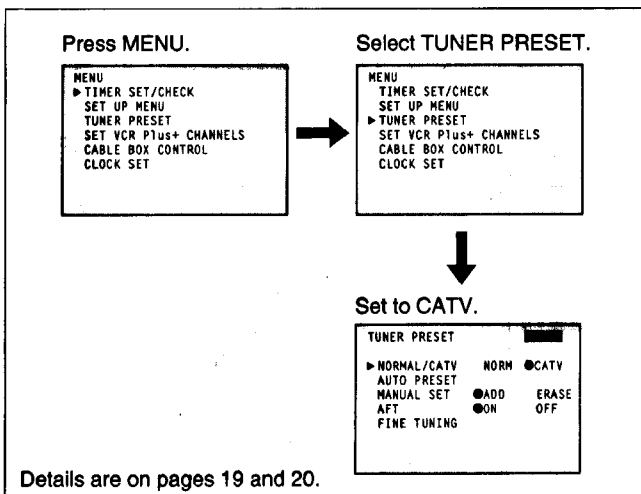

- 4 Preprogram the channels into the VCR.

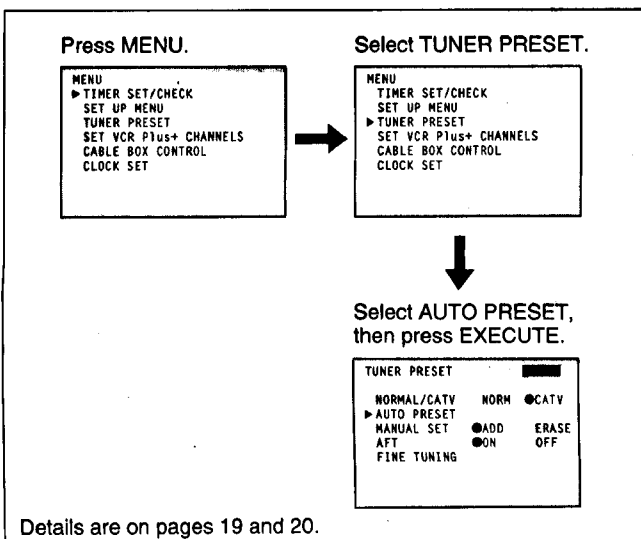

## VCR Plus+ Channel Setup

- 1 Find the VCR Plus+ Channel Listing in your program guide. For details, see page 42.
- 2 If the channels in the program guide are different from the channels that you actually use on your TV, set the channels that are different as follows:

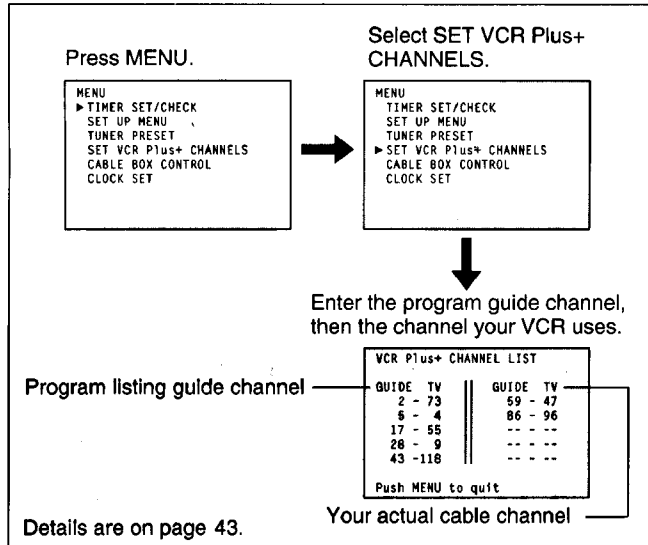

### To Watch TV

- 1 Turn your VCR off, or press the VCR's TV/VTR button until the VTR indicator in the display window goes off.
- 2 Select the channel with your cable box (if you have one), or directly tune with your TV (if you don't).

### To Watch the VCR

- 1a If you didn't use the A/V input:
  - Turn on the cable box.
  - Select CH 3 or CH 4 on the **cable box** (whichever you set on the back of the VCR).
  - Select the output channel of the cable box (usually 2, 3 or 4) on your TV.
- 1b If you made the A/V connections on page 7:  
Set your TV to the A/V input.

- 2 Insert a cassette and press ► PLAY.

Details are on page 28.

### To Record A Program

- 1 Press VCR Plus+ on the Remote Commander.
- 2 Enter the program's PlusCode number.
- 3 Press ONCE, DAILY, or WEEKLY on the Remote Commander.
- 4 Insert a blank cassette.
- 5 Press TIMER REC on the Remote Commander.

Details are on page 44.

## Hookup 4 - Incompatible Cable Box, Many "Scrambled" Channels

### Cable Hookup

#### Recommended Use:

Use this hookup if your cable company cannot supply a cable box that is compatible with the VCR's cable box control feature, and your cable system "scrambles" all, or most, channels.

#### Background

This VCR can record most unscrambled cable channels. Some cable systems "scramble" specific channels, usually premium, or pay-per-view channels.

If your cable company cannot supply a cable box that is compatible with the VCR's cable box control, and it is necessary to use a cable box because all, or most, channels are "scrambled", you must use this hookup. It will be necessary to set the cable box channel manually for each recording.

If your cable company cannot supply a compatible cable box, and your cable system only "scrambles" a few channels, use Hookup 3.

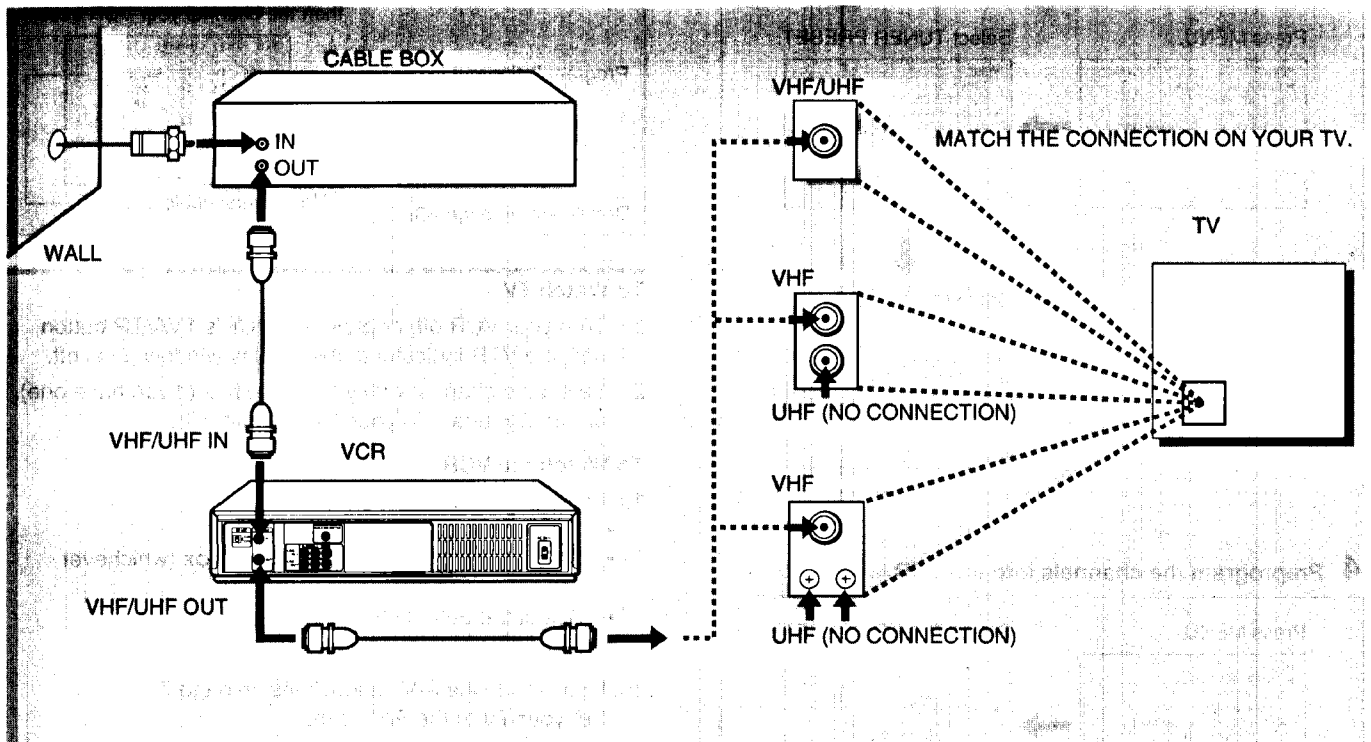

### What You Can and Can't Do With This Hookup

#### What You Can Do

- Record any channel by selecting the channel on the cable box.

#### What You Can't Do

- Record with the cable box turned off.
- Record by selecting channels directly from the VCR.
- Record one channel while watching another channel.
- Use the VCR's cable box control feature.

## VCR Setup

- 1 Set the RF UNIT on the VCR's rear panel to CH 3 or CH 4.  
If you made A/V connections, skip this step.

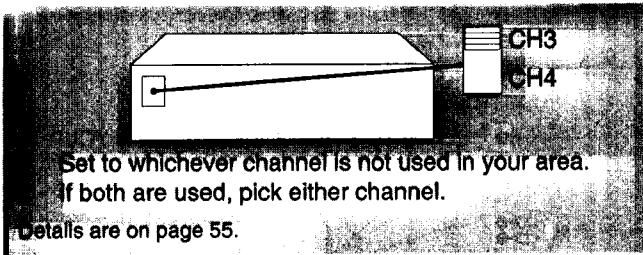

- 2 Switch on your cable box.
- 3 Preprogram the channels into the VCR.

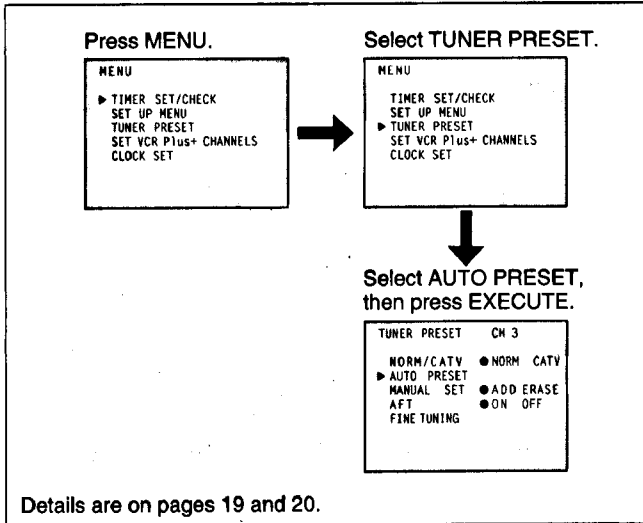

## VCR Plus+ Channel Setup

- 1 Find the VCR Plus+ Channel Listing in your program guide. For details, see page 42.
- 2 For all channels that you want to record, set each channel to the channel that your cable box uses for its output (usually 2, 3, or 4), as follows:

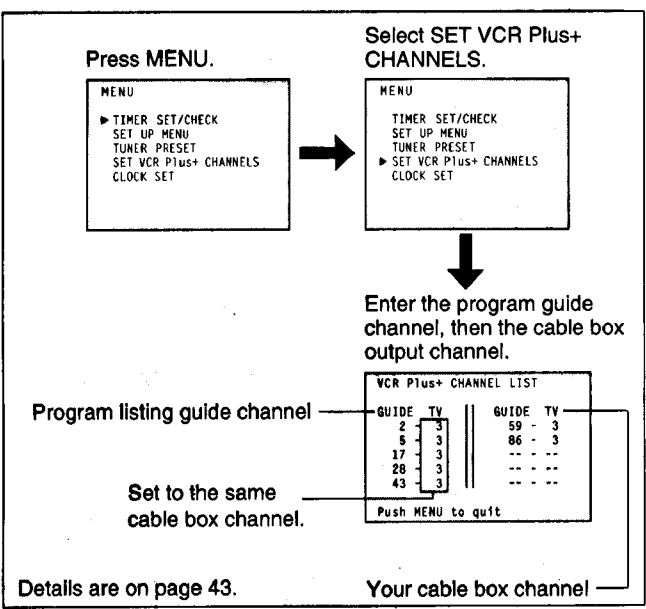

### To Watch the TV

- 1 Turn your VCR off, or press the VCR's TV/VTR button until the VTR indicator in the display window goes off.
- 2 Switch on your cable box.
- 3 Tune the TV to the cable box output channel (usually 2, 3, or 4).
- 4 Select the channel that you want to watch with your cable box.

### To Watch the VCR

- 1 Tune the TV to CH 3 or CH 4, (or to A/V input if you made A/V connections.)

- 2 Insert a cassette and press ► PLAY.

Details are on page 28.

### To Record A Program

- 1 Switch on the cable box.
- 2 Select the channel you wish to record on the cable box.
- 3 Press VCR Plus+ on the Remote Commander.
- 4 Enter the program's PlusCode number.
- 5 Press ONCE, DAILY, or WEEKLY on the Remote Commander.
- 6 Insert a blank cassette.
- 7 Press TIMER REC on the Remote Commander.
- 8 Leave the cable box on.

Details are on page 44.

## Hookup 5

### Antenna Hookup

Make the following connections if you're using an antenna (not cable TV).

#### 5A Use hookup 5A for a VHF/UHF antenna (you get Ch 2-13 and Ch 14 or higher).

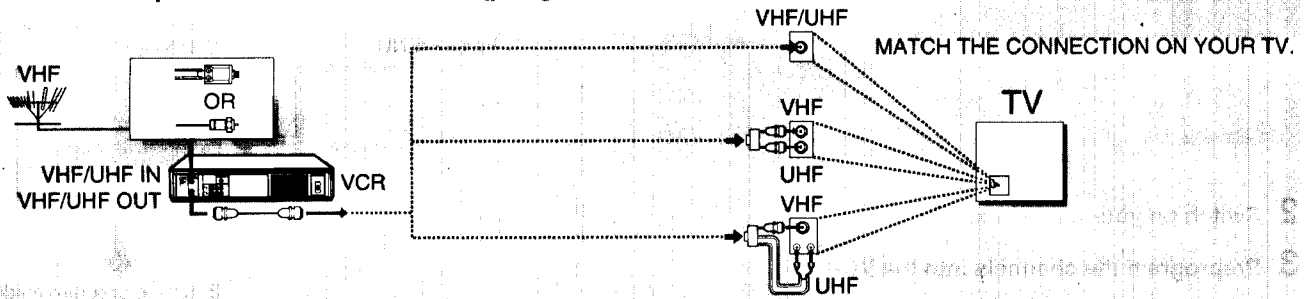

#### 5B Use hookup 5B for VHF only (you get Ch 2-13 only).

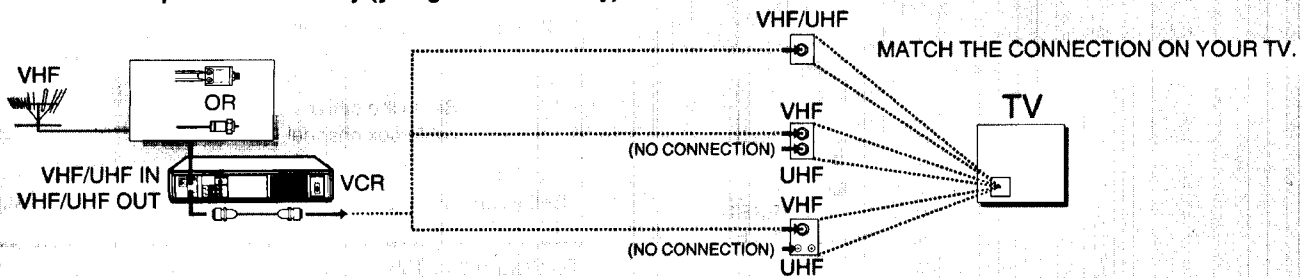

#### 5C Use hookup 5C for UHF only (you get Ch 14 or higher).

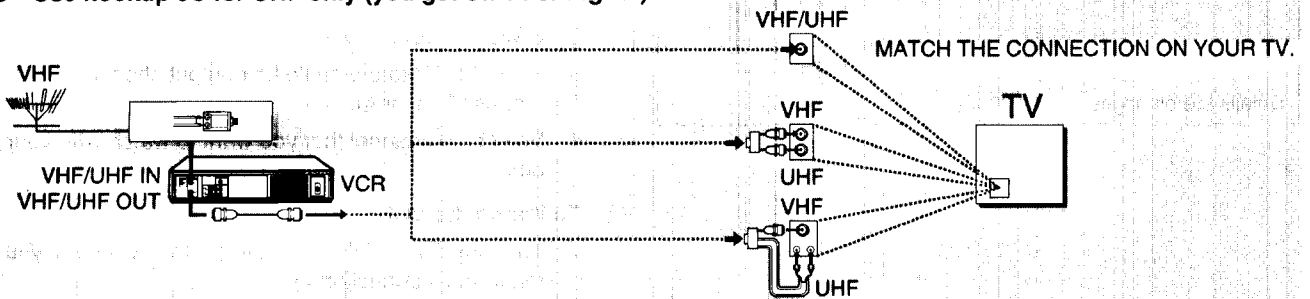

#### 5D Use hookup 5D if you are using separate VHF and UHF antennas.

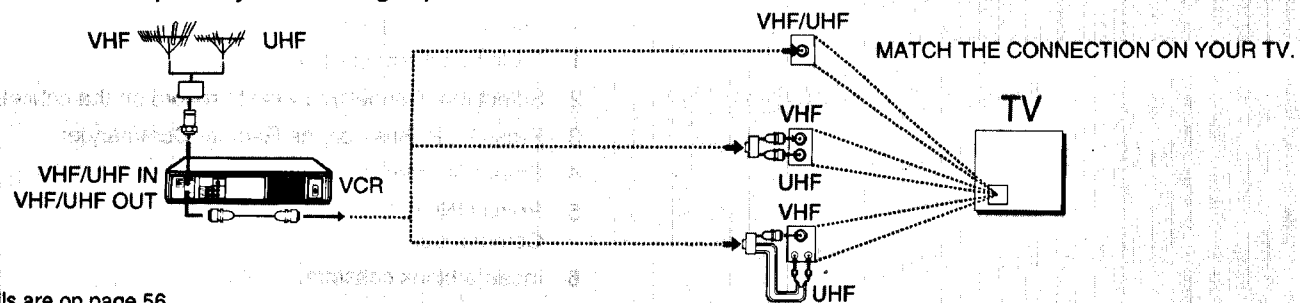

Details are on page 56.

## VCR Setup

- 1 Set the RF UNIT on the VCR's rear panel to CH 3 or CH 4.  
If you made A/V connections, skip this step.

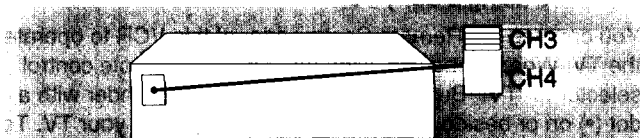

Set to whichever channel is not used in your area.  
If both are used, pick either channel.

Details are on page 55.

- 2 Set NORMAL/CATV to NORM.

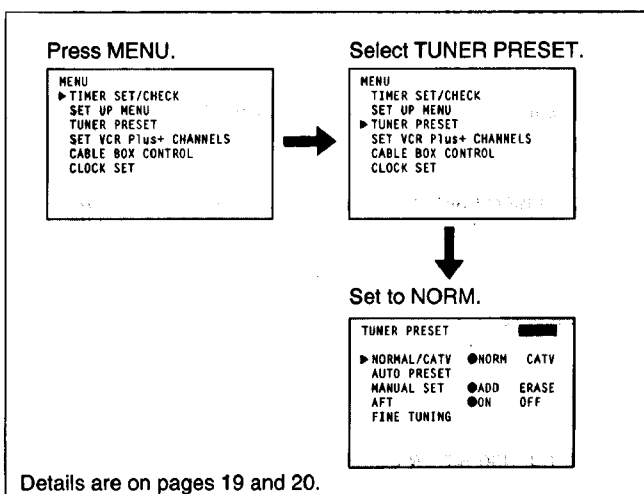

Details are on pages 19 and 20.

- 3 Preprogram the channels into the VCR.

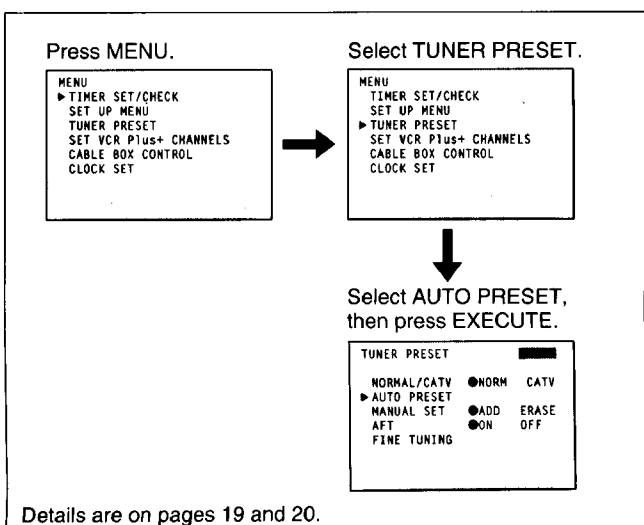

Details are on pages 19 and 20.

## VCR Plus+ Channel Setup

- 1 Find the VCR Plus+ Channel Listing in your program guide. For details, see page 42.
- 2 If the channels in the program guide are different from the channels that you actually use on your TV, set the channels that are different as follows:

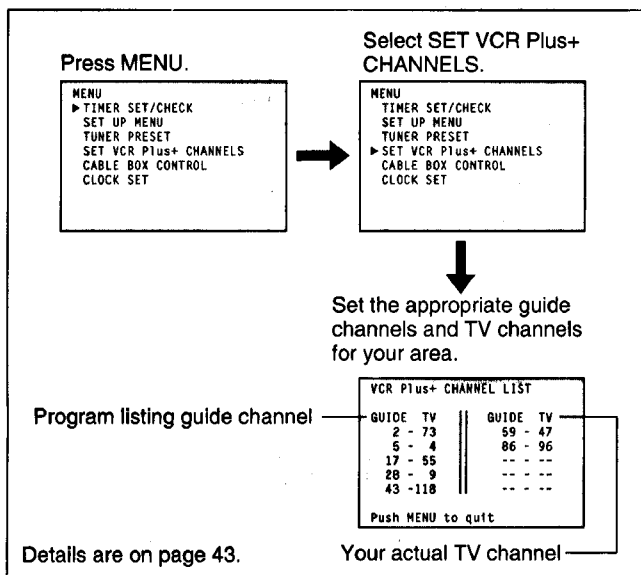

### To Watch the TV

- 1 Turn your VCR off, or press the VCR's TV/VTR button until the VTR indicator in the display window goes off.
- 2 Tune the TV normally.

### To Watch the VCR

- 1 Tune the TV to CH 3 or CH 4, whichever you set on the back of the VCR. (If you made the A/V connections on page 7, set your TV to the A/V input instead.)
- 2 Insert a cassette and press ▶ PLAY. If there's no picture on your TV, press the VCR's TV/VTR button until the VTR indicator comes on in the VCR's display window.

Details are on page 28.

### To Record A Program

- 1 Press VCR Plus+ on the Remote Commander.
- 2 Enter the program's PlusCode number.
- 3 Press ONCE, DAILY, or WEEKLY on the Remote Commander.
- 4 Insert a blank cassette.
- 5 Press TIMER REC on the Remote Commander.

Details are on page 44.

# Preparing the Remote Commander

## Inserting Batteries

- 1 Slide open and remove the cover.

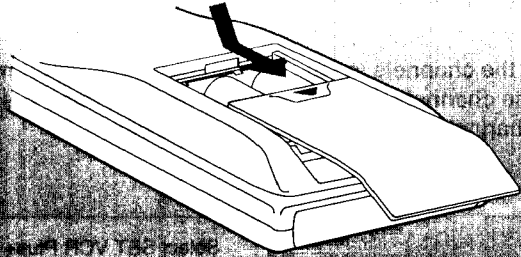

- 2 Insert two size AA (IEC designation R6) batteries with the polarity lined up correctly.

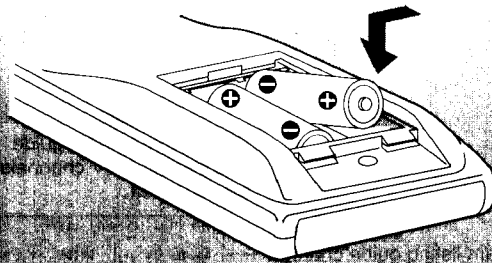

- 3 Replace and close the cover.

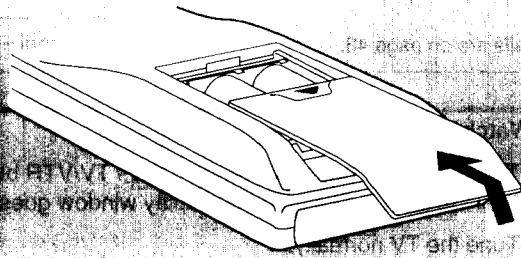

## Operating the VCR with the Remote Commander

Set the **TV/VTR** remote control selector at the top of the Remote Commander to "VTR."

### If you are using a Sony TV

You can use the Remote Commander of this VCR to operate the TV. When doing this, slide the **TV/VTR** remote control selector to "TV." Buttons on the Remote Commander with a dot (•) on or beside them can be used to operate your TV. To operate the VCR, return the **TV/VTR** remote control selector to "VTR."

## How to Use the Remote Commander

When you operate the VCR using the Remote Commander, point it at the remote sensor located on the VCR. For the location of the remote sensor, see "Identifying the Parts and Controls" on page 57.

When using the Remote Commander to change channels on a cable box, with the VCR's Cable box control feature turned on, point the Remote Commander at the VCR, not the cable box. For best results, separate the VCR and cable box.

### Notes on the handling of batteries

- With normal use, the batteries should last for approximately six months.
- If you do not use the Remote Commander for an extended period of time, remove the batteries to avoid possible damage from battery leakage.
- Do not use a new battery together with an old one.
- Do not use different types of batteries.



# Setting the Time and Date

You can set the VCR time and date on the TV screen using the Remote Commander.

## Example of Time and Date Setting

**Example: To set to 3:32 pm, July 4, 1993**

Use ▲ and ▼ to move the cursor.  
Use ◀ and ▶ to select the items.

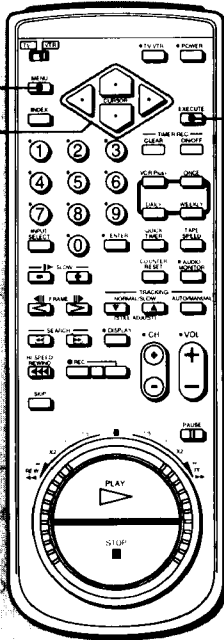

**1 Press MENU.**  
The main MENU appears.

MENU  
▶TIMER SET/CHECK  
SET UP MENU  
TUNER PRESET  
SET VCR Plus+ CHANNELS  
CABLE BOX CONTROL  
CLOCK SET

**2 Press ▲ or ▼ to move the cursor (▶) to CLOCK SET.**

MENU  
TIMER SET/CHECK  
SET UP MENU  
TUNER PRESET  
SET VCR Plus+ CHANNELS  
CABLE BOX CONTROL  
▶CLOCK SET

**3 Press EXECUTE.**  
“1/1 1993 FRI 12:00 AM” is displayed. The leftmost 1, in the “month” position, flashes.

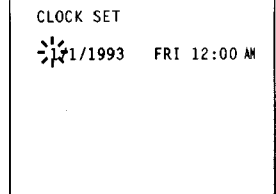

**4 Press ▲ or ▼ until 7 appears in the month position.**

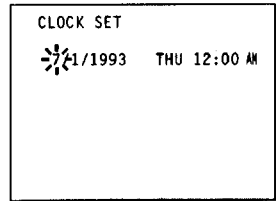

**5 Press ▶ to make the next number in the “day” position flash.**

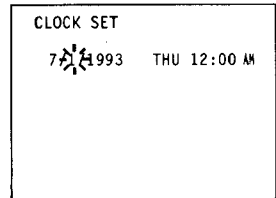

**6 Press ▲ or ▼ until “4” appears in the day position.**  
The day of the week is set automatically.

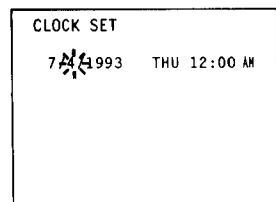

# Setting the Time and Date

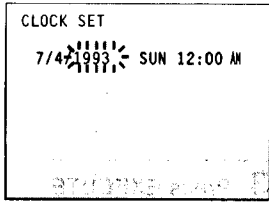
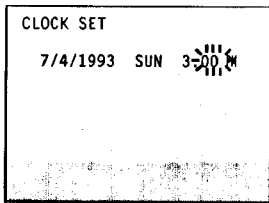
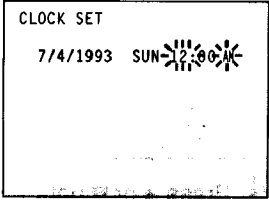
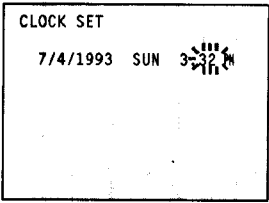
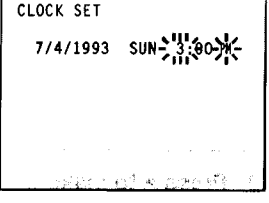
<p><b>7</b> Press <b>▶</b> to make the “year” position flash and press <b>▲</b> to change the year.</p>		<p><b>10</b> Press <b>▶</b> to make the “minutes” position flash.</p>	
<p><b>8</b> Press <b>▶</b> to make the “time” position flash.</p>		<p><b>11</b> Press <b>▲</b> or <b>▼</b> until “32” appears in the minutes position.</p>	
<p><b>9</b> Press <b>▲</b> or <b>▼</b> until “3:00 PM” appears.</p>		<p><b>12</b> Press <b>EXECUTE</b> at the same time that you hear the time signal. Pressing <b>EXECUTE</b> will set the clock to 3:32 pm 00 seconds.</p>	

## NOTES:

- Do not set the time and date during timer-activated recording, timer recording standby or quick-timer recording.
- When the time and date clock is displayed, the clock keeps running as long as no changes are made. The seconds are not reset to 00 when you return to the original screen.

# Presetting the Active Channels

This VCR is capable of receiving VHF channels 2 to 13, UHF channels 14 to 69 and CATV channels 1 to 125. These channels can be preset using the Remote Commander and the TUNER PRESET display. First, we recommend that you preset the active channels in your area using the automatic preset mode. Then, if there are any unwanted channels, disable them manually. If you have already decided which channels you wish to preset on the VCR, set them directly using the channel number buttons.

Before presetting channels, check the following points:

- Turn on the VCR and the TV.
- If you have connected the TV and the VCR using the VHF/UHF OUT on the VCR only, make sure that the TV is set to the correct channel (CH 3 or CH 4) for the VCR.
- Press TV/VTR to display the VTR indicator in the display window on the VCR.
- Press INPUT SELECT so that the channel number appears in the display window on the VCR.
- It is not necessary to use the TUNER PRESET function if the CABLE BOX CONTROL is set to "ON." If you want to use the TUNER PRESET function, make sure the CABLE BOX CONTROL is set to "OFF."

## Presetting All Receivable Channels Automatically

Use ▲ and ▼ to move the cursor.  
Use ◀ and ▶ to select the items.

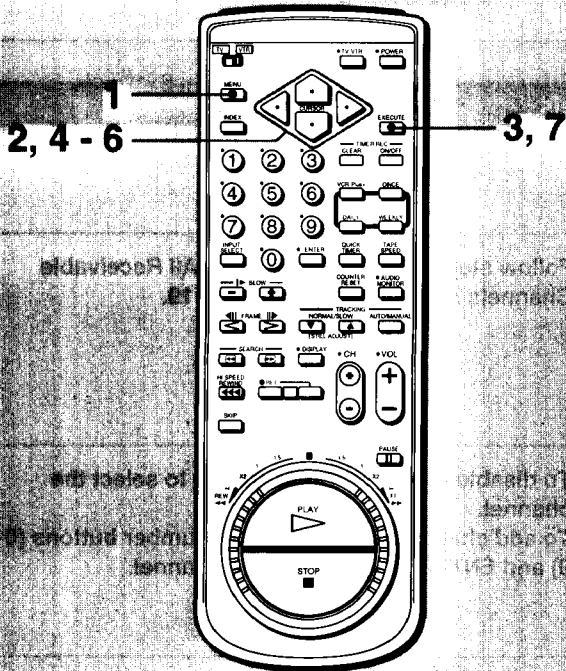

- 1 Press MENU.**  
The main MENU appears.

```
MENU
▶TIMER SET/CHECK
SET UP MENU
TUNER PRESET
SET VCR Plus+ CHANNELS
CABLE BOX CONTROL
CLOCK SET
```

- 2 Press ▲ or ▼ to move the cursor (▶) to TUNER PRESET.**

```
MENU
TIMER SET/CHECK
SET UP MENU
▶TUNER PRESET
SET VCR Plus+ CHANNELS
CABLE BOX CONTROL
CLOCK SET
```

- 3 Press EXECUTE.**  
The TUNER PRESET menu is displayed.

```
TUNER PRESET
NORMAL/CATV ● NORM CATV
AUTO PRESET
▶MANUAL SET ● ADD ERASE
AFT ● ON OFF
FINE TUNING
```

- 4 Press ▲ or ▼ to move the cursor to NORMAL/CATV.**

```
TUNER PRESET
▶NORMAL/CATV ● NORM CATV
AUTO PRESET
MANUAL SET ● ADD ERASE
AFT ● ON OFF
FINE TUNING
```

## Presetting the Active Channels

### 5 Press ◀ or ▶ to select

#### **NORM or CATV.**

NORM presets the VHF and UHF channels; CATV presets your cable TV channels. The lowest channel number, 2 for NORM and 1 for CATV, will appear on the screen.

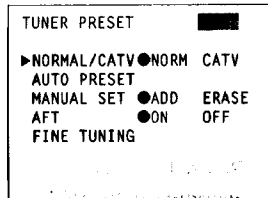

### 7 Press EXECUTE

Receivable channels are preset in numerical sequence. When no more channels can be found, the presetting stops and the picture of the lowest numbered channel is displayed on the tape counter. The message "Please wait" is flashing while presetting on the TV screen.

### 6 Press ▲ or ▼ to move the cursor to **AUTO PRESET.**

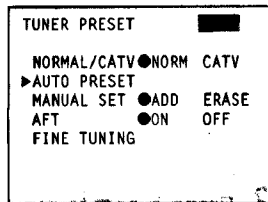

#### **NOTE:**

The VCR automatically exits from the TUNER PRESET menu if you don't proceed for more than one minute.

## Presetting Desired Channels or Disabling Unwanted Channels

After automatic presetting, you can disable and/or add channels.

Use ▲ and ▼ to move the cursor.  
Use ◀ and ▶ to select the items.

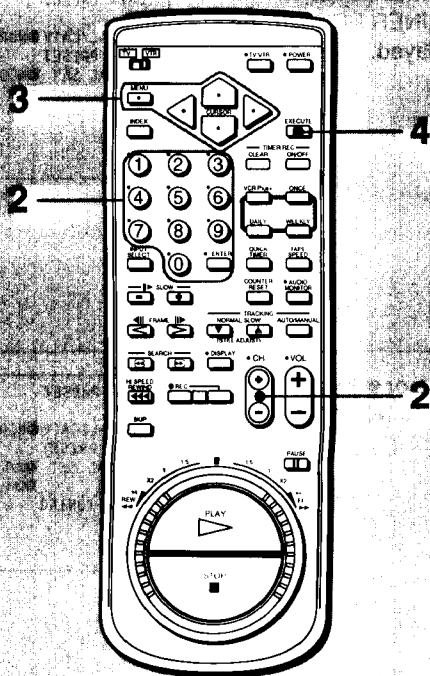

### 1 Follow steps 1 to 3 in "Presetting All Receivable Channels Automatically" on page 19.

**2** To disable channels, press CH +/- to select the channel.  
To add channels, press channel number buttons (0 to 9) and ENTER key to select the channel.

**3** To disable channels, press ◀ or ▶ to select ERASE.  
To add channels, press ◀ or ▶ to select ADD.

**4** Press EXECUTE.  
When you press CH +/-, the disabled channels are removed and the added channels are displayed.

## Fine-tuning

Normally, the Auto Fine Tuning (AFT) setting on the menu is set to "ON," and the AFT function fine-tunes the picture. If the picture of a channel is not acceptable, fine-tune it manually.

**1** Display the **TUNER PRESET** menu referring to steps 1 to 3 in "Presetting All Receivable Channels Automatically" (page 19)

**2** Press **▲** or **▼** to move the cursor to **FINE TUNING**. The fine tuning indicator is displayed.

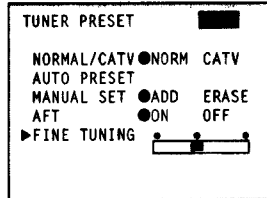

**3** Press **◀** or **▶** to get a clearer picture. The AFT ON/OFF automatically switches to "OFF."

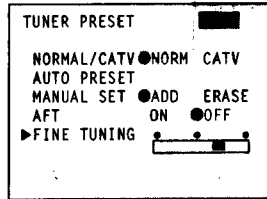

**4** Press **▲** to move the cursor to **AFT** and select "ON" if you cannot get a better picture. Then, press **EXECUTE**.

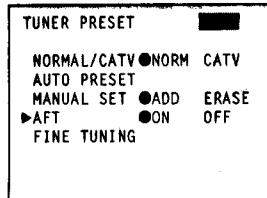

### The FINE TUNING indicator

The FINE TUNING indicator shows the operable fine-tuning range and stops at the optimal point of reception. When a broadcast is received in an optimal condition, the indicator may not be at the center position.

## Cable TV Channel Assignment

Cable TV systems use letters or numerals to designate the channels. To tune-in a CATV channel, refer to the chart below which shows the CATV channel, numbers on this VCR and the corresponding CATV channel. Note that the channel number assignment shown in the chart may not correspond to the channel number used by your local cable company. Check with your local cable TV company for more information on the available channels.

Number on this VCR	1	2	...	13	14	15	16	17	18					
Corresponding CATV channel	A-8	2	...	13	A	B	C	D	E					
	19	20	21	22	23	24	25	26	27	28	29	30	31	32
	F	G	H	I	J	K	L	M	N	O	P	Q	R	S
	33	34	35	36	37	...	94	95	96	97	98	99		
	T	U	V	W	W+1	...	W+58	A-5	A-4	A-3	A-2	A-1		
	100	...	125											
	W+59	...	W+84											

This VCR is designed to correspond to the standard cable system. However, the cable TV services may vary from area to area. Your local cable TV company may adopt either the HRC<sup>1)</sup> or IRC<sup>2)</sup> cable system. This VCR is capable of receiving either of these cable systems in the best condition.

### 1) HRC (Harmonic Related Carriers)

All channels except for 5 and 6 are 1250 kHz lower than the standard cable system. Channels 5 and 6 are 750 kHz higher than the standard cable system.

### 2) IRC (Incremental Related Carriers)

All channels except for 5 and 6 are the same as the standard cable system. Channels 5 and 6 are 2000 kHz higher than the standard cable system.

### FINE TUNING indicator for receiving HRC or IRC cable systems

Even when the signals are received in optimal condition, the FINE TUNING indicator will not stay at the center position for channels higher or lower than the standard cable system due to the difference in the frequency.

### NOTE:

Many cable TV systems use scrambled or encoded signals for certain channels, usually premium or pay-per-view channels.

A cable box is necessary to receive scrambled channels.

# Activating the Cable Box Control Function

Your VCR includes a Cable Box Control feature which allows the VCR to control channel selection on most cable boxes.

The use of compatible cable box brand is shown on the following page.

The CABLE BOX CONTROL must be set to "ON," and the code number and the output channel must be set to match your cable box before you can use it. Detail for connecting your cable box to the VCR to control the cable box with the Remote Commander, make connections using Hookup 2 on page 8.

When CABLE BOX CONTROL is set to "ON," the VCR will control the cable box channel for timer recording. In addition, you can use the VCR's Remote Commander to change channels on the cable box whenever the cable box and the VCR are turned on.

## Note on setting the cable box and Cable Mouse

Make sure that the Cable Mouse is positioned near to and above the sensor on the cable box so that the signal from the Cable Mouse is received correctly.

The cable box should not be too close to the VCR.

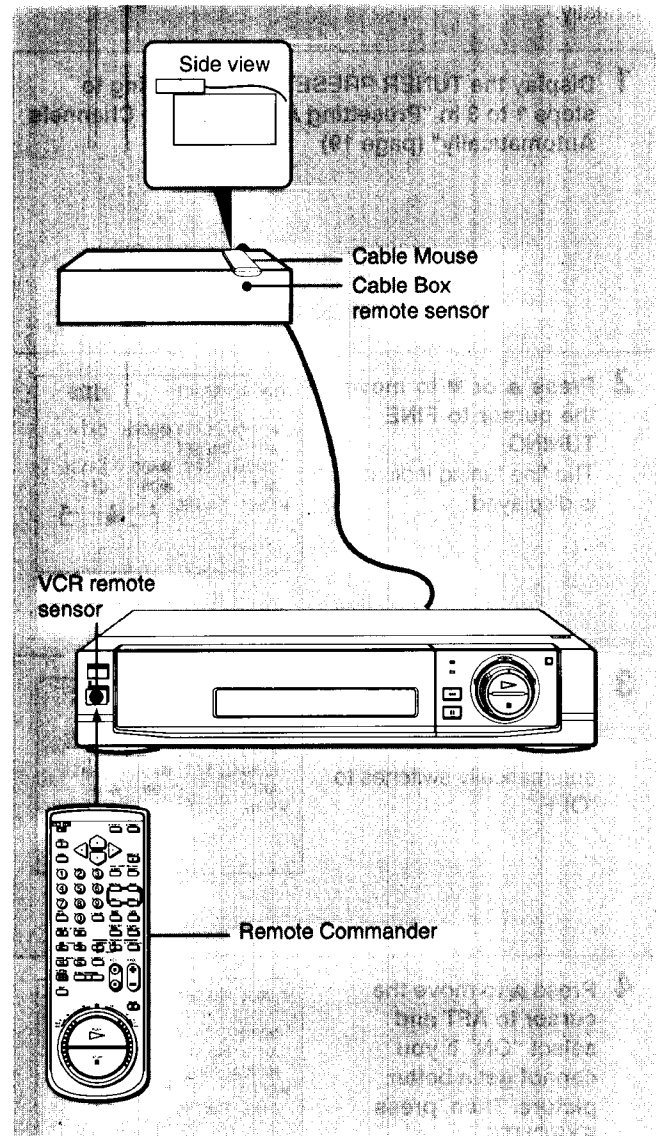

## Setting the Cable Box Control

To use the cable box control function, enter the cable box code number and select the cable box output channel as explained below.

Use ▲ and ▼ to move the cursor.  
Use ◀ and ▶ to select the items.

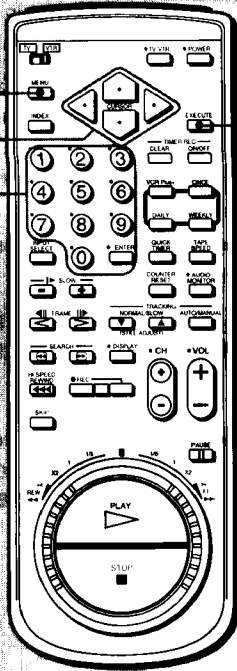

**2** Press ▲ or ▼ to move the cursor (▶) to **CABLE BOX CONTROL**, then press **EXECUTE**.

```
MENU
TIMER SET/CHECK
SET UP MENU
TUNER PRESET
SET VCR Plus+ CHANNELS
▶CABLE BOX CONTROL
CLOCK SET
```

**3** Press ◀ or ▶ to select **"ON,"** then press **EXECUTE**.

```
CABLE BOX CONTROL
●ON OFF
```

Use ◀ ▶ to select  
Push EXECUTE for first  
time setup  
Push MENU to quit

**4** Enter the cable box code number under **CABLE BOX Code No.** as listed in the chart on page 24, then press **EXECUTE**.

Your CABLE BOX Code No.



Enter your CABLE BOX Code No. using 0-9 keys  
Refer to the Operating Manual for the Code  
Then push EXECUTE

**1** Press **MENU**.  
The main MENU appears.

```
MENU
▶TIMER SET/CHECK
SET UP MENU
TUNER PRESET
SET VCR Plus+ CHANNELS
CABLE BOX CONTROL
CLOCK SET
```

**5** Select the cable box output channel under **CABLE BOX OUTPUT CH**, then press **EXECUTE**.

Your CABLE BOX Output CH

```
●CH2
CH3
CH4
LINE [LINE IN 1 on VCR]
```

Use ▲ ▼ to select CABLE BOX CH. Then push EXECUTE

## Activating the Cable Box Control Function

### Cable box code number chart

In step 4 on page 23, enter the code number of your cable box as listed in the chart below.

Brand	IR Code No.
Hamlin	14, 15
Jerrold/ General Instrument	1, 2, 3, 4
Oak	17, 18
Panasonic	12, 13
Philips	22
Pioneer	8, 9
Regal	14, 15
Regency	20
Scientific Atlanta	5, 6
Tocom	10, 11
Zenith	7

The VCR contains 42 cable box codes (1-42). If your cable box is not listed in the chart, it may be possible to control it using one of the other (1-42) codes. You may want to try other codes before calling your cable company to see if they can supply a cable box that is in the chart.

If your cable box is listed in the chart, but does not respond, first check the placement of the Cable Mouse (see page 22), and try placing the cable box and VCR away from each other (do not place the cable box directly on top of the VCR). If the cable box still does not respond, you can try other codes.

### Checking the Cable Box Control Setting

Using the information provided below, check to make sure that you have made the correct Cable Box Control setting.

#### Note

Make sure to do the following when using a cable box.

- Tap the buttons lightly. Do not hold the buttons down.
- Position the cable box away from the VCR. Do not point the Remote Commander at the cable box. Point it at the VCR.

- 1 Press CH +/- on the Remote Commander. Does the channel indicator on the cable box change?
- 2 Press all 10 channel number buttons on the Remote Commander (0 to 9). Does the channel indicator on the cable box change?

If the answer to both 1 and 2 is "yes," you have made the correct setting.

#### If you cannot get your VCR to control the cable box

Try the setup again making sure to use the correct code number.

If, after checking your setup, you are sure that the VCR will not control your cable box, contact your cable company. They may be able to supply a compatible cable box.



# Using the SET UP MENU

Before using your VCR, make your preferred audio and video display choices from the SET UP MENU.

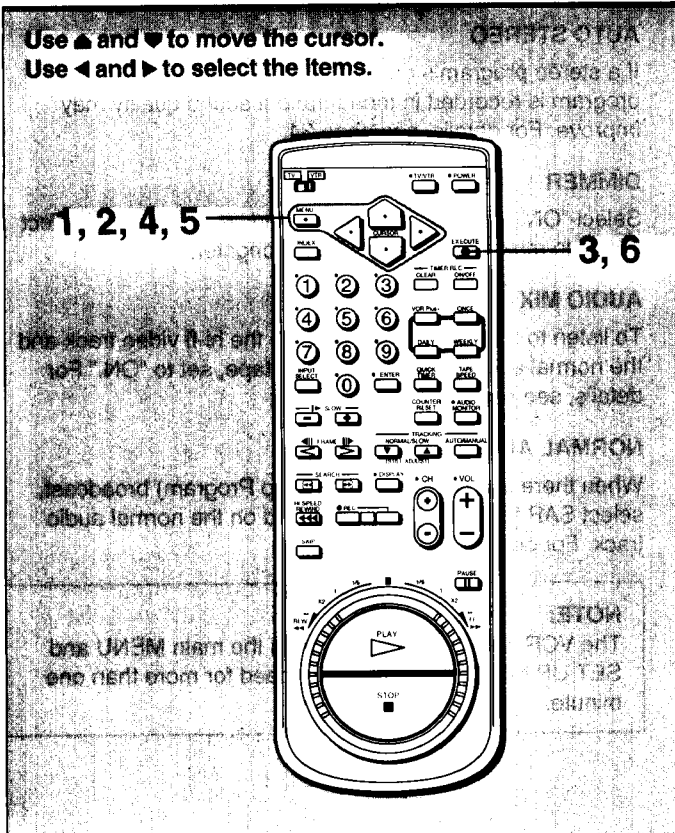

Use ▲ and ▼ to move the cursor.  
Use ◀ and ▶ to select the items.

1, 2, 4, 5

3, 6

**3 Press EXECUTE.**  
The SET UP MENU appears.

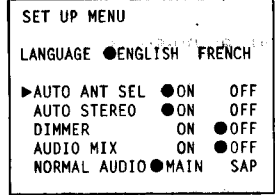

**4 Press ▲ or ▼ to move the cursor to the desired menu choice.**  
(For Menu Choices, see the next page.)

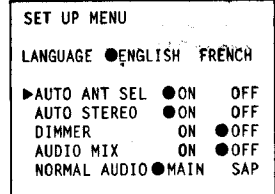

**5 Press ◀ or ▶ to move the dot (•) to the desired setting.**

**1 Press MENU.**  
The main MENU appears.

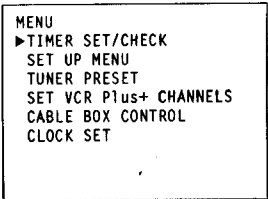

**2 Press ▲ or ▼ to move the cursor (▶) to SET UP MENU.**

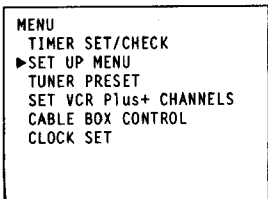

**6 Press EXECUTE to return to the original screen.**  
The settings are stored. The displayed page is stored unless the power plug is disconnected.

### Menu Choices

#### LANGUAGE (Canadian versions only)

You can preset your VCR to display screen information in either English or French.

#### AUTO ANT SEL (Automatic Antenna Selector)

- If your TV is connected only to VHF/UHF OUT on the VCR, set AUTO SET SEL to "ON."

When playing back a cassette, the picture is automatically displayed on the screen simply by selecting the channel for the VCR on the TV. To watch TV programs selected on the TV, press TV/VTR to turn off the VTR indicator in the display window.

- If your TV is connected to both VHF/UHF OUT and LINE OUT on the VCR, set to "OFF."

When playing back a cassette, select the input for the VCR on the TV.

To watch TV programs selected on the TV, select the tuner input.

#### AUTO STEREO

If a stereo program's reception is poor, set to "OFF." The program is recorded in monaural but sound quality may improve. For details, see page 34.

#### DIMMER

Select "ON" to make the display window dimmer and select "OFF" to make the display window brighter.

#### AUDIO MIX

To listen to sound recorded on both the hi-fi video track and the normal audio track of the audio tape, set to "ON." For details, see page 31.

#### NORMAL AUDIO

When there is a SAP (Second Audio Program) broadcast, select SAP to record the SAP sound on the normal audio track. For details, see page 34.

#### NOTE:

The VCR automatically exits from the main MENU and SET UP MENU if you don't proceed for more than one minute.

# Playback

This section shows you how to play back a video cassette.

## Inserting a Video Cassette

- 1 Insert a video cassette as shown below.
- 2 Gently press the center of the front side of the cassette until the mechanism draws it into the compartment.  
When the cassette has been loaded, the cassette indicator (📺) lights in the display window and the VCR turns on automatically.

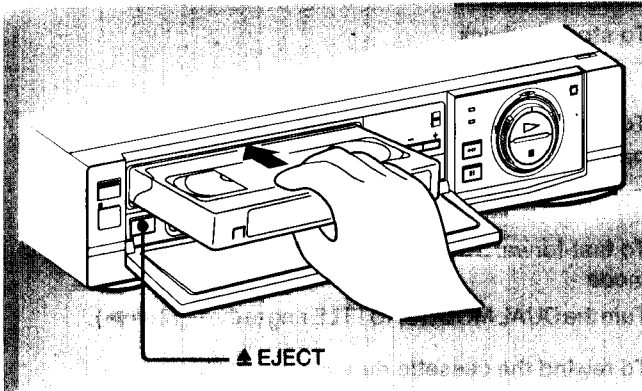

### NOTE:

If you insert a cassette without a safety tab, playback starts automatically (auto playback function).

### Ejecting the cassette

Press ▲ EJECT on the VCR. You can eject the cassette when the power is off. When you press ▲ EJECT, the power is turned on. After ejecting the cassette, the power automatically shuts off.

### Protecting your cassette against accidental erasure

Cassettes have a safety tab to protect against accidental recording. Break off the safety tab with a screwdriver or other tool. If the safety tab is removed, the cassette will be ejected when you try to record on it.

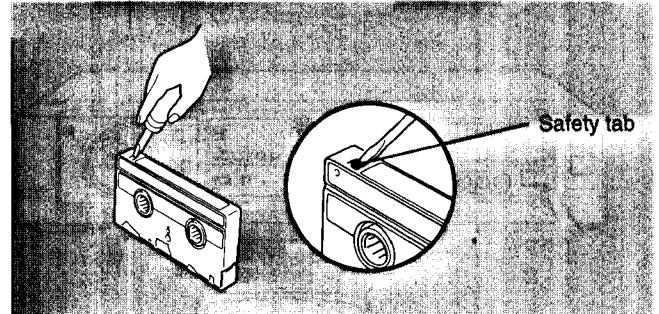

To record on a cassette with the safety tab broken off, simply cover the tab hole with adhesive tape.

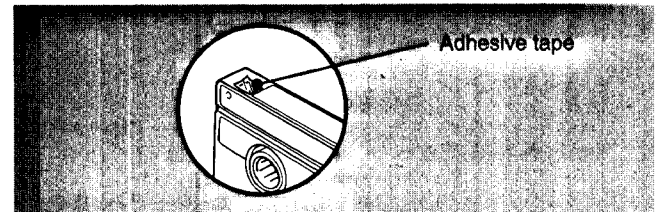

### Maximum recording time of a cassette

Recording in either the SP or EP mode is possible with this VCR. When recording, select the desired recording mode (SP or EP) using TAPE SPEED on the Remote Commander. During playback, the VCR automatically detects the recording format, and then plays back the cassette in the appropriate mode. A cassette recorded in the EP mode runs three times as slowly as a cassette recorded in the SP mode. Refer to the chart below for the recording/playback times available.

Cassette tape	Recording / Playback time	
	SP mode	EP mode
T-180	3 hrs.	9 hrs.
T-160	2 hrs. 40 min.	8 hrs.
T-120	2 hrs.	6 hrs.
T-60	1 hr.	3 hrs.
T-30	30 min.	1 hr. 30 min.

### Cassettes recorded in LP mode

Playback of cassettes recorded in LP mode is also possible with this VCR. However, playback in modes other than normal forward speed is not guaranteed. This VCR is not designed to record in the LP mode.

## Playback

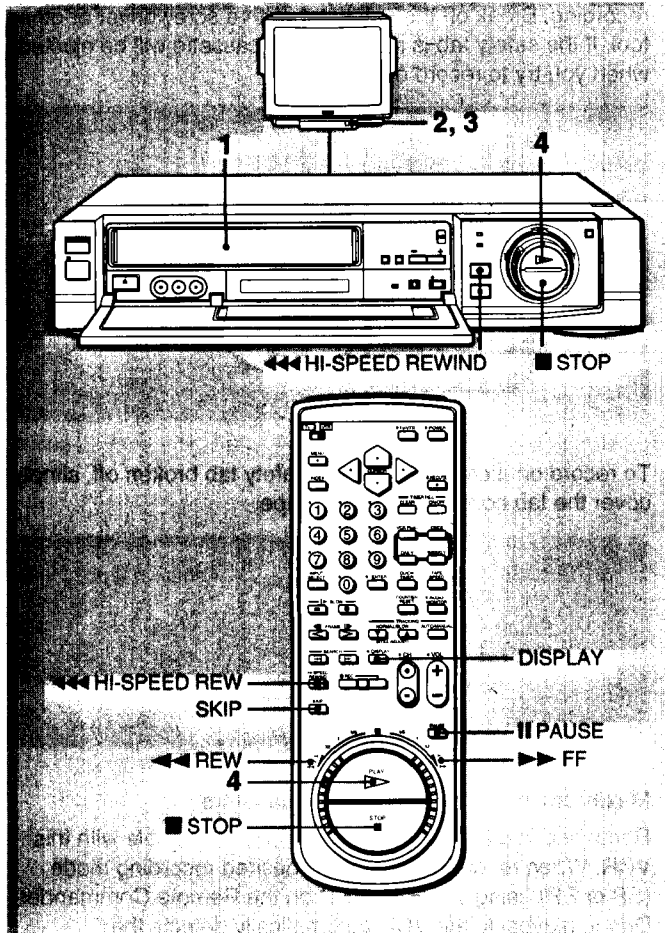

**1** Insert a cassette.

**2** Turn on the TV.

**3** If your TV is connected to both VHF/UHF OUT and LINE OUT on the VCR, select the input for the VCR. If your TV is connected only to the VHF/UHF OUT on the VCR, select the channel for the VCR (CH 3 or CH 4).

**4** Press ► PLAY.

**To stop playback**

Press ■ STOP.

**To stop playback for a moment**

Press || PAUSE.

Press || PAUSE again or ► PLAY to resume playback.

**To fast-forward the cassette at high speed during stop mode**

Turn the DUAL MODE SHUTTLE ring to the right (►►).

**To rewind the cassette during stop mode**

Turn the DUAL MODE SHUTTLE ring to the left (◄◄).

**To rewind the cassette at high speed**

Press ◄◄◄ HI-SPEED REWIND.

**To rewind the cassette to its beginning and to play back automatically (auto playback function)**

Press ► PLAY while depressing ◄◄◄ HI-SPEED REWIND or by using the DUAL MODE SHUTTLE ring.

You cannot use the Remote Commander for the auto playback function.

**To reduce streaks and/or snow and obtain a clearer picture**

Switch the PICTURE switch to NOISE REDUCTION when playing back rental or poor quality tapes.

**When the cassette reaches its end**

The cassette automatically rewinds to the beginning (auto rewind), and power remains on.

## The Display

To delete or call up the Display on the TV screen, press DISPLAY on the Remote Commander.

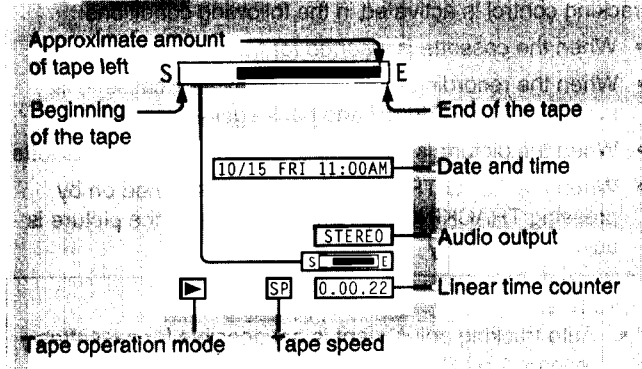

To turn off the Display, press DISPLAY.

### NOTES:

- The remaining tape length displayed is approximate. Therefore, use it only as an approximate reference.
- When you insert a cassette with a short tape length such as T-20, T-30 or a non-standard commercially available cassette, this indicator may not function correctly.
- The on-screen Display cannot be displayed on the screen during still mode, or slow motion playback.
- Audio output, tape operation mode, and tape speed are displayed when you make changes to them. They are displayed even when the Display is turned off.

## Indexing Tape Contents

Before recording or playback, press COUNTER RESET on the Remote Commander to reset the counter to zero. By noting the setting, you can find that point later by referring to the counter. Use the label on the cassette to list the programs and their counter readings.

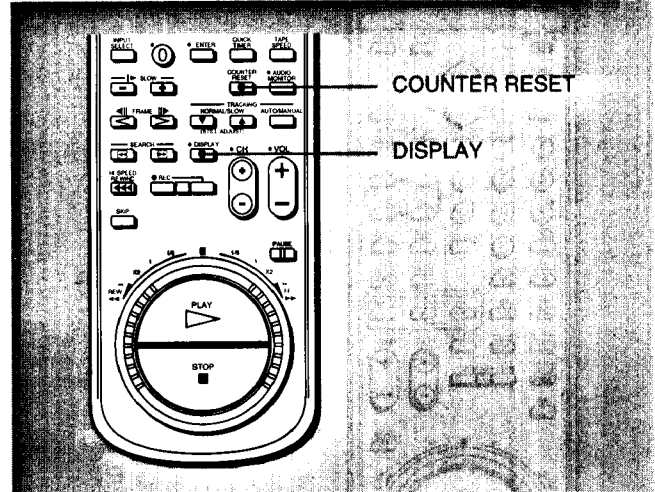

### NOTES ON COUNTER READING:

- After a cassette is ejected, the counter reading is retained. When a cassette is reinserted the counter returns to "0H00M00S."
- The counter will not advance on portions of the tape on which no recording has been made.

## Playing Back Externally-Recorded Tapes

When playing back a cassette recorded on another VCR, the tracking condition is automatically adjusted. You can also adjust the tracking condition and the sharpness manually according to the following instructions.

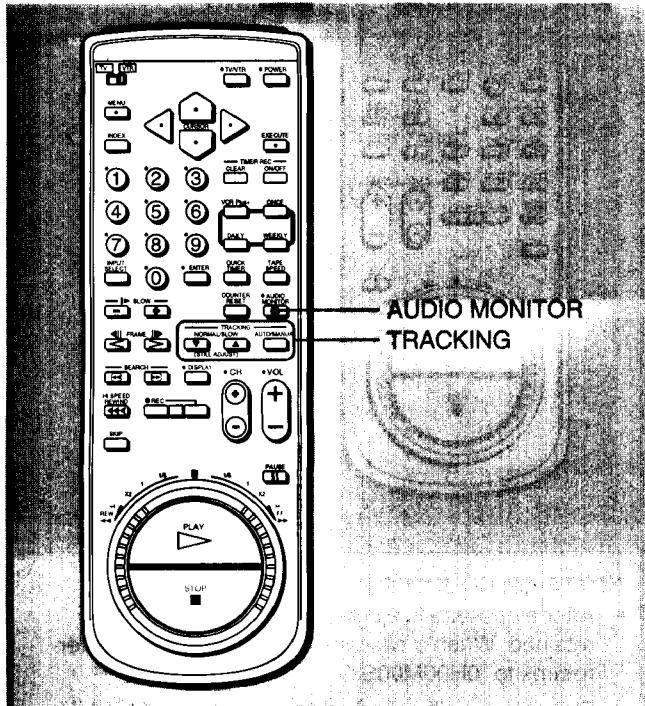

### Manual tracking adjustment

When the playback picture has streaks and/or snow during normal playback, adjust the picture manually with TRACKING NORMAL/SLOW and STILL ADJUST ▼/▲.

Press either ▲ or ▼ for the best possible picture. The tracking meter will appear on the TV screen and the AUTO TRACKING indicator will turn off.

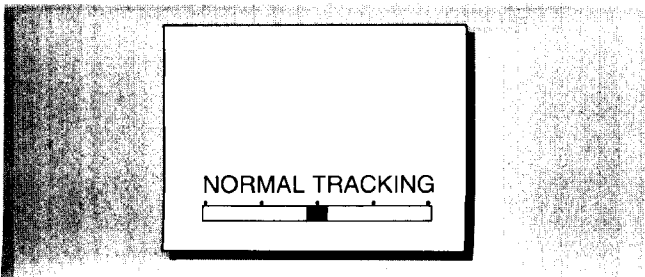

### Automatic tracking adjustment

The tracking condition is automatically adjusted on this VCR. The AUTO TRACKING indicator flashes while the VCR is searching for the optimal tracking condition and lights when optimum playback picture is obtained. The automatic tracking control is activated in the following conditions:

- When the cassette is inserted for the first time
- When the recording mode on the playback cassette is switched from SP to EP and back again
- When the picture is distorted by scratches on the cassette
- When the AUTO TRACKING indicator is turned on by pressing TRACKING AUTO/MANUAL after the picture is adjusted manually

#### NOTES:

- Auto tracking adjustment is not possible for cassettes recorded in LP mode.
- Auto tracking adjustment may be impossible and the tracking indicator may not appear on the TV screen when the recording condition of the cassette is poor.
- During auto tracking adjustment, streaks or noise may occur.

## Selecting the Monitor Sound

You can play back cassettes on which stereo sound or bilingual programs are recorded. Press AUDIO MONITOR to select the desired sound mode. Each press of the button changes the display on the TV screen.

#### NOTE:

When you play back a cassette recorded in monaural, the sound is heard in monaural regardless of the setting of the AUDIO MONITOR.

### Sound Mode

Stereo Indicator	On-screen Display	Sound heard	
		Stereo tape	Bilingual tape
Lights up	STEREO	Stereo	Left and right channels
Lights up	LCH	Left channel	Left channel
Lights up	RCH	Right channel	Right channel
No indication	None	Monaural on normal audio track	Sound on normal audio track (SAP)

## Listening to Mixed Hi-Fi and Normal Track Sound

You can hear sound recorded on the hi-fi video track and the normal audio track simultaneously. This allows you to listen to an audio-inserted cassette.

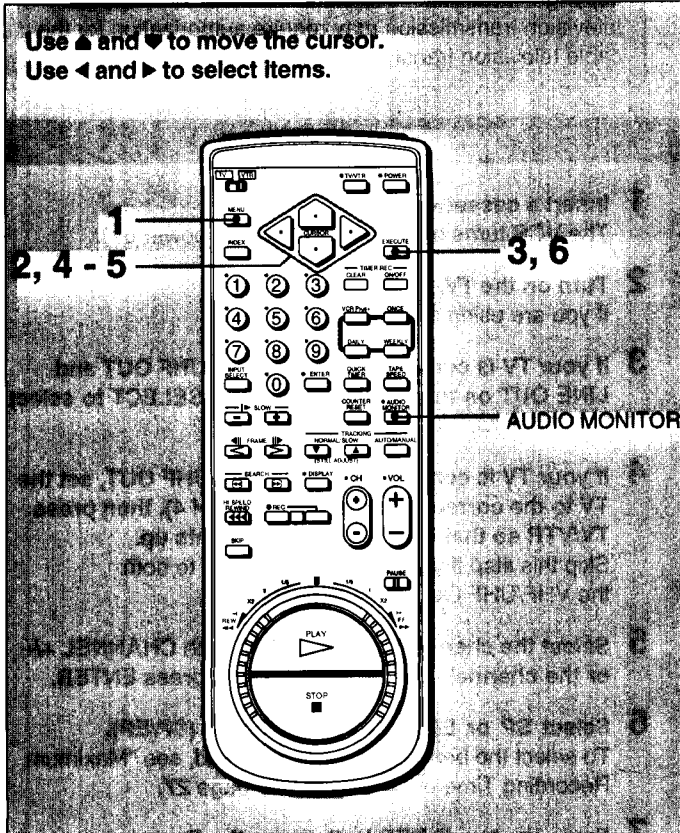

Use ▲ and ▼ to move the cursor.  
Use ◀ and ▶ to select items.

**3 Press EXECUTE.**  
The SET UP MENU appears.

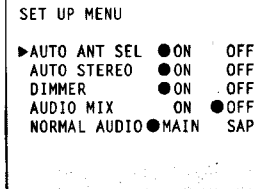

**4 Press ▲ or ▼ to move the cursor to AUDIO MIX.**

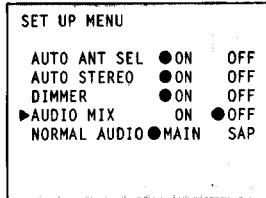

**5 Press ◀ or ▶ to move the dot (•) to "ON."**

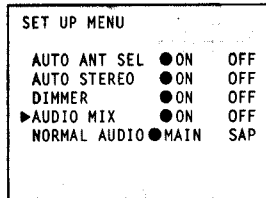

**1 Press MENU.**  
The main MENU appears.

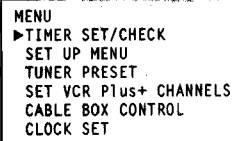

**6 Press EXECUTE to return to the original screen.**

**2 Press ▲ or ▼ to move the cursor (▶) to SET UP MENU.**

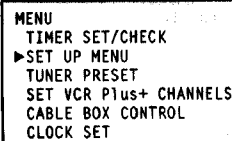

**NOTES:**

- When you set AUDIO MIX to "ON," the AUDIO MONITOR button does not function.
- Reset to "OFF" after listening to the sound in audio mix mode.

# Recording TV Programs

Before you begin, check the following points:

- Make sure that the connections have been made correctly (see pages 6 to 15).
- Check the input mode indicator in the display window of the VCR.

## CAUTION:

Television programs, films, video cassettes and other materials may be copyrighted. Unauthorized recording of such material may be contrary to the provisions of the copyright laws. Also, use of this recorder with cable television transmission may require authorization for the cable television transmission and/or program owner.

## Recording TV Programs

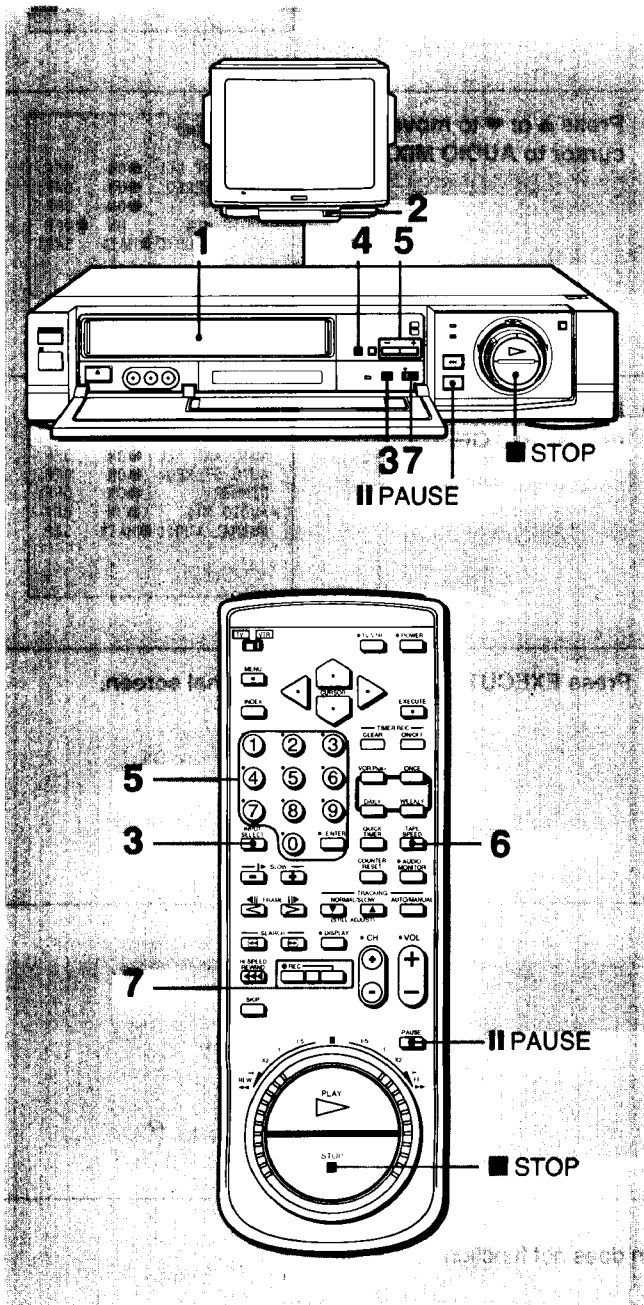

- 1 Insert a cassette.**  
The VCR turns on automatically (auto power on).
- 2 Turn on the TV.**  
If you are using a cable box, turn it on.
- 3 If your TV is connected to both VHF/UHF OUT and LINE OUT on the VCR, press INPUT SELECT to select the input for the VCR.**
- 4 If your TV is connected only to VHF/UHF OUT, set the TV to the correct channel (CH 3 or CH 4), then press TV/VTR so that the VTR indicator lights up.**  
Skip this step if your VCR is connected to both the VHF/UHF OUT and LINE OUT.
- 5 Select the channel to be recorded with CHANNEL +/- or the channel number buttons and press ENTER.**
- 6 Select SP or EP with TAPE SPEED (SP/EP).**  
To select the best recording tape speed, see "Maximum Recording Time of a Cassette" on page 27.
- 7 Press the two ● REC buttons on the Remote Commander at the same time, or the ● REC button on the VCR.**  
The REC indicator lights up on the VCR.

### To stop recording

Press ■ STOP.

### To pause the cassette

Press || PAUSE. To resume recording, press || PAUSE. When the recording pause mode lasts for approximately 5 minutes, the VCR enters the stop mode.

### When the cassette reaches its end

The cassette rewinds to the beginning and the power remains on.



## Pausing

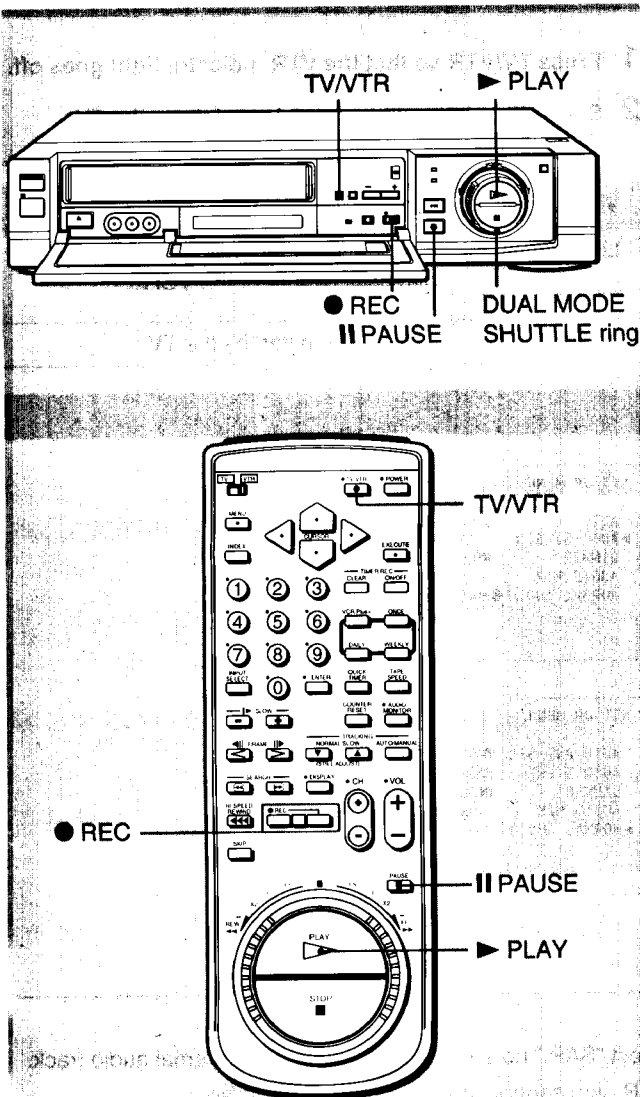

## Technique 1

You can stop recording an unwanted scene and resume recording smoothly.

- 1 Press II PAUSE when an unwanted scene appears.**  
Recording will stop and the VCR enters the recording pause mode.
- 2 Press II PAUSE at the desired point to release the pause mode.**  
Recording resumes from the point set in step 1.

## Technique 2

When an unwanted scene has already started recording, you can return the cassette to the desired point, have the VCR standby in the recording pause mode, and resume recording at the desired scene.

- 1 Press II PAUSE to set the VCR to the recording pause mode.**
- 2 Turn the DUAL MODE SHUTTLE ring on the VCR to the left to search for the point from which you wish to continue recording.**
- 3 Release the DUAL MODE SHUTTLE ring on the VCR at the desired point.**  
After an instant in still mode, the VCR automatically enters the recording pause mode.
- 4 Press II PAUSE.**  
Recording resumes.

## Recording TV Programs

### Recording with the TV Off

Turn off the power of the TV or color monitor.  
There will be no interference with the recording.

When using a cable box, make sure to leave the power for it set to on.

### Watching One TV Program While Recording Another

- 1 Press TV/VTR so that the VTR indicator light goes off.
- 2 Select the channel you want to watch on the TV.

VTR Indicator	Picture on the TV Screen
Lights up	Channel selected by the VCR or the playback picture of the VCR
No indication	Channel selected by the TV

### Recording Multi-Channel TV Sound (MTS)

#### To record a stereo broadcast:

When a stereo broadcast program is received, the STEREO indicator lights up. The stereo program is automatically recorded in stereo. If a stereo program's reception is poor, set AUTO STEREO to "OFF" in the SET UP MENU. (See page 26.) The sound is heard in monaural but the noise is reduced.

#### To record SAP (Second Audio Program) broadcast:

Normally, set NORMAL AUDIO to "MAIN" in the SET UP MENU. The main sound is recorded on the normal track. To record the SAP sound on the normal audio track, set NORMAL AUDIO to "SAP" in the SET UP MENU.

To monitor the SAP sound during recording, press AUDIO MONITOR to light the SAP indicator in the display window.

SET UP MENU		
AUTO ANT SEL	● ON	OFF
▶ AUTO STEREO	ON	● OFF
DIMMER	● ON	OFF
AUDIO MIX	ON	● OFF
NORMAL AUDIO	● MAIN	SAP

SET UP MENU		
AUTO ANT SEL	● ON	OFF
AUTO STEREO	● ON	OFF
DIMMER	● ON	OFF
AUDIO MIX	ON	● OFF
▶ NORMAL AUDIO	MAIN	● SAP

#### NOTES:

- When not recording an SAP broadcast, select "MAIN." If you select "SAP," no sound is recorded on the normal audio track.
- When the TV is connected only to the VHF/UHF OUT on the VCR, you cannot hear the program in stereo.
- In order to hear stereo playback, it is necessary to connect the L/R audio out connections of the VCR to a stereo monitor TV, or stereo audio system.

# Timer Recording

The timer recording function lets you preset your VCR to record up to eight programs within a one-month period. You'll do this procedure from the **TIMER SET/CHECK** display on your TV.

## As a First Step

Before setting the timer, make sure that:

- The time and date clock is set correctly. (See "Setting the Time and Date" on page 17.)
- The cassette is long enough to record all the programs.
- The cassette has a safety tab in place. If you insert a cassette with no safety tab and press **TIMER REC (ON/OFF)**, the cassette automatically ejects from the VCR.
- The VCR and TV are both turned on.
- When you use a cable box, use **Hookup 2** and set the **CABLE BOX CONTROL** (See "Setting the Cable Box Control" on page 23). Turn the cable box on.

## Setting the Timer

**EXAMPLE:** Here's how to record a program broadcast on channel 26 from 9:00 pm to 10:55 pm on Saturday, July 10 in EP mode:

**Use ▲ and ▼ to move the cursor.**  
**Use ◀ and ▶ to select items.**

- 1 Press MENU.**  
The main MENU appears.

MENU
▶TIMER SET/CHECK
SET UP MENU
TUNER PRESET
SET VCR Plus+ CHANNELS
CABLE BOX CONTROL
CLOCK SET
- 2 Press ▲ or ▼ to move the cursor (▶) to **TIMER SET/CHECK**.**

MENU
▶TIMER SET/CHECK
SET UP MENU
TUNER PRESET
SET VCR Plus+ CHANNELS
CABLE BOX CONTROL
CLOCK SET
- 3 Press EXECUTE.**  
The **TIMER SET/CHECK** display appears on the screen. A short beep alerts you if the clock is not set properly. To reset the clock, refer to "Setting the Time and Date" (page 17).

TIMER SET/CHECK			
DATE	START	STOP	CH
▶-/-	-:-	-:-	- -
-/-	-:-	-:-	- -
-/-	-:-	-:-	- -
-/-	-:-	-:-	- -
-/-	-:-	-:-	- -
-/-	-:-	-:-	- -
-/-	-:-	-:-	- -
-/-	-:-	-:-	- -

# Timer Recording

## 4 Press ▶.

Make sure that today's date is flashing. If it isn't, reset the clock to the correct time. See "Setting the Time and Date" (page 17).

TIMER SET/CHECK	7/	4SUN
DATE	START	STOP CH
7/10SAT	9:00PM	10:55PM 26
-/-	-:-	-:-
-/-	-:-	-:-
-/-	-:-	-:-
-/-	-:-	-:-
-/-	-:-	-:-
-/-	-:-	-:-
-/-	-:-	-:-
-/-	-:-	-:-

## 10 Press ▶ to flash the recording speed position, then ▲ or ▼ or TAPE SPEED until "EP" appears.

To change or correct a setting before entering it, press ◀ to return to the item you wish to change.

TIMER SET/CHECK	7/	4SUN
DATE	START	STOP CH
7/10SAT	9:00PM	10:55PM 26
-/-	-:-	-:-
-/-	-:-	-:-
-/-	-:-	-:-
-/-	-:-	-:-
-/-	-:-	-:-
-/-	-:-	-:-
-/-	-:-	-:-
-/-	-:-	-:-

## 5 Press ▲ to set the month and date to "7/10 SAT."

The day of the week is automatically set.

TIMER SET/CHECK	7/	4SUN
DATE	START	STOP CH
7/10SAT	9:00PM	10:55PM 26
-/-	-:-	-:-
-/-	-:-	-:-
-/-	-:-	-:-
-/-	-:-	-:-
-/-	-:-	-:-
-/-	-:-	-:-
-/-	-:-	-:-
-/-	-:-	-:-

## 11 Press ▶ to store the setting.

When all of the settings stop flashing and display a "▶" in the leftmost column, you've completed the setting.

To preset another program, move the cursor to the next line and repeat steps 4 to 11.

TIMER SET/CHECK	7/	4SUN
DATE	START	STOP CH
▶7/10SAT	9:00PM	10:55PM 26
-/-	-:-	-:-
-/-	-:-	-:-
-/-	-:-	-:-
-/-	-:-	-:-
-/-	-:-	-:-
-/-	-:-	-:-
-/-	-:-	-:-
-/-	-:-	-:-

## 6 Press ▶ to flash the hours position under "START," then ▲ or ▼ until "9:-- PM" appears.

TIMER SET/CHECK	7/	4SUN
DATE	START	STOP CH
7/10SAT	9:--PM	10:55PM 26
-/-	-:-	-:-
-/-	-:-	-:-
-/-	-:-	-:-
-/-	-:-	-:-
-/-	-:-	-:-
-/-	-:-	-:-
-/-	-:-	-:-
-/-	-:-	-:-

## 12 Press EXECUTE.

The message "Please push TIMER REC to set timer" appears on the TV screen.

## 7 Press ▶ to flash the minutes position under "START," then ▲ or ▼ until "00" appears.

TIMER SET/CHECK	7/	4SUN
DATE	START	STOP CH
7/10SAT	9:00PM	10:55PM 26
-/-	-:-	-:-
-/-	-:-	-:-
-/-	-:-	-:-
-/-	-:-	-:-
-/-	-:-	-:-
-/-	-:-	-:-
-/-	-:-	-:-
-/-	-:-	-:-

## 13 Press TIMER REC (ON/OFF).

The VCR enters the timer recording standby mode and the TIMER REC (recording) indicator lights up.

When using a cable box, make sure to leave it on.

### To stop timer recording:

To stop timer recording while a program is being recorded, press TIMER REC (ON/OFF).

## 8 Press ▶.

The cursor blinks in the time field under "STOP." Set the time to finish recording, referring to steps 6 and 7.

TIMER SET/CHECK	7/	4SUN
DATE	START	STOP CH
7/10SAT	9:00PM	10:55PM 26
-/-	-:-	-:-
-/-	-:-	-:-
-/-	-:-	-:-
-/-	-:-	-:-
-/-	-:-	-:-
-/-	-:-	-:-
-/-	-:-	-:-
-/-	-:-	-:-

## 9 Press ▶ to flash the "CH" field, then press ▲ or ▼ until "26" appears.

Only the channels set in the VCR will appear. You can also use the CHANNEL +/- or channel number buttons. When using a cable box, the cable box channels appear under the CH section.

TIMER SET/CHECK	7/	4SUN
DATE	START	STOP CH
7/10SAT	9:00PM	10:55PM 26
-/-	-:-	-:-
-/-	-:-	-:-
-/-	-:-	-:-
-/-	-:-	-:-
-/-	-:-	-:-
-/-	-:-	-:-
-/-	-:-	-:-
-/-	-:-	-:-

## NOTES:

- To change or correct the setting before completing it, press ◀ to return to the item you wish to change.
- To record video sources from LINE IN 1 or 2 jacks, press INPUT SELECT in step 4 to 11 to move the screen cursor to LINE 1 or 2 in the "CH" position. This cursor returns to channel number on the third press.
- When CABLE BOX CONTROL is set to "ON," timer recording cannot be done through LINE IN.
- If you don't proceed for more than one minute, the VCR automatically exits from the TIMER SET/CHECK menu.

### Daily/Weekly Recording

You can preset your VCR for daily or weekly recording. Daily recording records the same program every day of the week, while weekly recording records the same program on the same day every week. Follow steps 1 to 4 in "Setting the Timer" (pages 35 and 36).

Each time you press **▼**, the indicator under the "DATE" column changes to one of these choices:

- SUN—SAT (Every day of the week)
- ↓
- MON—SAT (Every day except Sunday)
- ↓
- MON—FRI (Every day except Saturday and Sunday)
- ↓
- EVERY SAT
- .
- .
- EVERY TUE
- ↓
- EVERY MON
- ↓
- EVERY SUN

### The Timer Recording Standby Mode

When you return the VCR to the timer recording standby mode, you can record any previously preset programs. The VCR turns on automatically to record the first preset program. When it finishes recording, the power automatically shuts off.

To stop timer recording, press **TIMER REC (ON/OFF)**.

### Buttons Operable During Timer Recording

<b>TIMER REC (ON/OFF)</b>	To stop timer recording (See "Indexing Tape Contents," page 29.)
<b>COUNTER RESET</b>	(See "Indexing Tape Contents," page 29.)
<b>TV/VTR</b>	(See "Watching One TV Program While Recording Another," page 34.)
<b>DISPLAY</b>	(See "The Display," page 29.)
<b>MENU</b>	For checking the programs only (See "Checking the Timer Settings," page 39.)

**NOTE:**  
 If a power interruption occurs during timer recording, recording will stop and your VCR will turn off. If power is restored within three hours, and it's before the recording end time, recording will start again from that point. If the interruption lasts for more than three hours, any presettings will be erased and you'll need to reset the time and date for your programs. Note that the tape counter will return to "0H00M00S."

## Overlapping Timer Recordings

### Case 1

If you preset two programs to record at the same time . . .

The program listed first on the TIMER SET/CHECK display has priority over the other programs. The timer settings for lower priority programs will be deleted from the TIMER SET/CHECK display when recording begins for the first program.

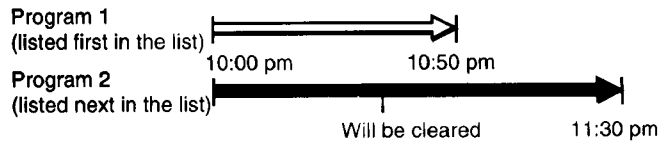

### Case 2

If you set program 2 to record at the same time you set program 1 to finish recording . . .

The last 20 seconds of program 1 will not be recorded.

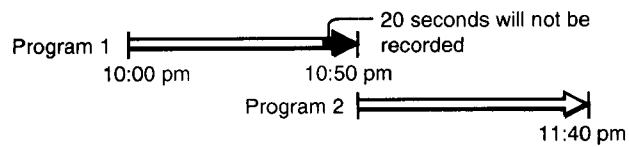

### Case 3

If you set program 2 to record before program 1 has finished recording . . .

Program 2 will begin recording before program 1 has finished.

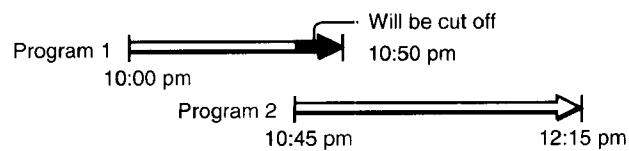

## Checking the Timer Settings

Here's how to display your timer settings to confirm the programs you wish to record.

**Use ▲ and ▼ to move the cursor.  
Use ◀ and ▶ to select items.**

- 3 Press MENU.**  
The main MENU appears.

MENU  
▶TIMER SET/CHECK  
SET UP MENU  
TUNER PRESET  
SET VCR Plus+ CHANNELS  
CABLE BOX CONTROL  
CLOCK SET
- 4 Press ▲ or ▼ to move the cursor (▶) to TIMER SET/CHECK.**

MENU  
▶TIMER SET/CHECK  
SET UP MENU  
TUNER PRESET  
SET VCR Plus+ CHANNELS  
CABLE BOX CONTROL  
CLOCK SET
- 5 Press EXECUTE.**  
The TIMER SET/CHECK display appears.

TIMER SET/CHECK	4/14 WED
DATE	START STOP CH
▶ 4/24 SAT	7:00 AM 8:00 PM 6 SP
5/13 THU	10:30 PM 11:15 PM 50 EP
MON - SAT	1:00 AM 3:00 AM LINE2 EP
EVERY SUN	12:55 PM 1:30 AM 112 SP
-/-	-:- -:- -:-
-/-	-:- -:- -:-
-/-	-:- -:- -:-
-/-	-:- -:- -:-
- 6 Press EXECUTE to return to the original screen.**
- 7 Press TIMER REC (ON/OFF).**  
The VCR returns to the timer recording standby mode.  
Leave the cable box on.

**1 Press TIMER REC (ON/OFF).**  
The TIMER REC (recording) indicator on the VCR turns off.

**2 Press POWER.**

**NOTES:**

- If you set a program to record only one time, that setting is erased from the TIMER SET/CHECK display when the recording has finished.
- To check the timer settings during timer recording, follow steps 3 to 6 above.

## Changing or Cancelling the Timer Settings

Here's how to change or cancel any timer settings from the TIMER SET/CHECK display.

**Use ▲ and ▼ to move the cursor.  
Use ◀ and ▶ to select items.**

- 1 Display the TIMER SET/CHECK menu on the TV screen by following the procedures outlined in "Checking the Timer Settings" on page 39.**

TIMER SET/CHECK 4/14 WED				
DATE	START	STOP	CH	
▶ 4/24 SAT	7:00 AM	8:00 PM	6 SP	
5/13 THU	10:30 PM	11:15 PM	50 EP	
MON - SAT	1:00 AM	3:00 AM	LINE2 EP	
EVERY SUN	12:55 PM	1:30 AM	112 SP	
-/-	-:-	-:-	--	
-/-	-:-	-:-	--	
-/-	-:-	-:-	--	
-/-	-:-	-:-	--	
- 2 Press ▲ or ▼ to move the cursor (▶) to the program you wish to change or cancel.**

TIMER SET/CHECK 4/14 WED				
DATE	START	STOP	CH	
▶ 4/24 SAT	7:00 AM	8:00 PM	6 SP	
5/13 THU	10:30 PM	11:15 PM	50 EP	
MON - SAT	1:00 AM	3:00 AM	LINE2 EP	
EVERY SUN	12:55 PM	1:30 AM	112 SP	
-/-	-:-	-:-	--	
-/-	-:-	-:-	--	
-/-	-:-	-:-	--	
-/-	-:-	-:-	--	
- 3 To change a program, select the item to be changed by pressing ◀ or ▶, then make changes by pressing ▲ or ▼.  
To cancel it, press TIMER CLEAR.**  
Repeat this step to change or cancel other settings.
- 4 Press EXECUTE.**  
This stores the changes and returns you to the original screen.
- 5 Press TIMER REC (ON/OFF).**  
This returns you to the timer recording standby mode.  
Leave the cable box on.



**Using the VCR Before Timer Recording Starts**

If you want to use your VCR while it's in the timer recording standby mode, you must first turn off the **TIMER REC** (recording) indicator on the VCR. Here's how:

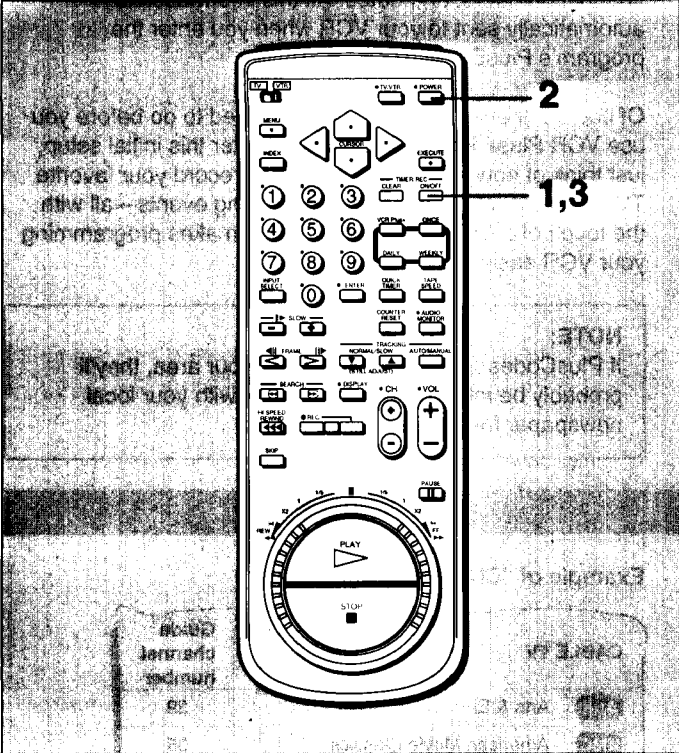

**1 Press **TIMER REC (ON/OFF)**.**  
The **TIMER REC** (recording) indicator on the VCR turns off and the VCR leaves the timer recording standby mode.

**2 Press **POWER**.**  
The VCR is ready for use.

**3 After using the VCR, press **TIMER REC (ON/OFF)**.**  
The VCR returns to the timer recording standby mode and the **TIMER REC** (recording) indicator lights up.  
Leave the cable box on.

# Introducing VCR Plus+

VCR Plus+ is a feature used in Sony VCRs that simplifies the task of programming your VCR to make unattended recordings. Here's how it works:

Whenever you want to record a TV program, all you need to do is to look up the program's "PlusCode," a number assigned to each program that's published in the TV section of most newspapers, cable TV listings, and even *TV Guide* magazine.

					PlusCode
5:30	14	MOVIE — Musical (2hrs.)	33044		
	2	SPORTS — Golf (1hr. 25min.)	42060		
	CNN	—WS	9974		
6:30	2 3 4	DRAMA — Comedy (2hrs.)	17390		
	5	SCIENCE AND TECHNOLOGY (1hr. 15min.)	73457		

Then, just enter the number of the program you want—using the Remote Commander—and the VCR is automatically programmed to record that show. It's that simple. With VCR Plus+, you no longer have to go through a lengthy and often repetitive procedure when you set start and stop times, channel numbers, and dates. All this information is automatically sent to your VCR when you enter the program's PlusCode!

Of course, there's some setup you'll need to do before you use VCR Plus+ for the first time. But after this initial setup, just think of how much easier it'll be to record your favorite TV programs, cable movies, and sporting events—all with the touch of a few buttons. VCR Plus+ makes programming your VCR easier than ever!

**NOTE:**  
If PlusCodes aren't yet available in your area, they'll probably be introduced soon. Check with your local newspaper for details.

## VCR Plus+ Setup Instructions

Setting up your VCR to use VCR Plus+ involves coordinating the TV channel number (the number you turn to on your TV or VCR to watch a program) with the guide channel (the number that's assigned to that channel in your program guide).

If you don't have cable TV (i.e., if your TV receives its signal from an antenna only), the TV channel number and the guide channel number will probably be the same, in which case you'll only have to check that the two numbers match. For numbers that don't match, you must first perform the procedures that follow to get these channel numbers synchronized with each other.

To get the guide channel numbers, find the Channel Line-Up Chart in the program guide for your area that features VCR PlusCodes. It usually looks like the example to the right.

If you have cable TV, you should then get the TV channel numbers for each channel from your cable company. (You may already know them.) Then for **channel numbers that are different**, enter the program guide channels (from the Program Guide), on the left, and the actual TV channels (from your cable system), on the right, as shown on page 43.

### Example of "Channel Line-Up Chart"

CABLE TV	Guide channel number
A&E Arts & Entertainment Network	39
AMC American Movie Classics	35
BRV Bravo (program grid only)	54
CNN Cable News Network	42
CSP C-SPAN	28
DIS The Disney Channel	53
DSC The Discover Channel	37
ESN ESPN	34
FAM The Family Channel	47
HBO Home Box Office	33
LIF Lifetime	46
MAX Cinemax	45
MSG Madison Square Gardens Network	19
MTV Music Television	48
NIK Nickelodeon	38
SC Sports Channel	59
SCA Sports Channel America	70
SHO Showtime	41
TBS TBS SuperStation	43
TMC The Movie Channel	58
TNN The Nashville Network	49
TNT Turner Network News	52
USA USA Network	44

For each channel your VCR receives, use the Channel Line-Up Chart to check that the channel numbers match. For example, if HBO is listed in the Channel Line-Up Chart on channel 33, and your VCR receives HBO on channel 15, you need to coordinate these numbers using the following procedures. For channels in which the numbers are the same (for example, if your VCR receives HBO on channel 33, and the guide channel number is 33), you can skip these procedures.

**Example:**

Guide Channel (from "Channel Line-Up Chart" in your program guide)	TV Channel (channel you actually use on you VCR)
33 (Home Box Office)	15

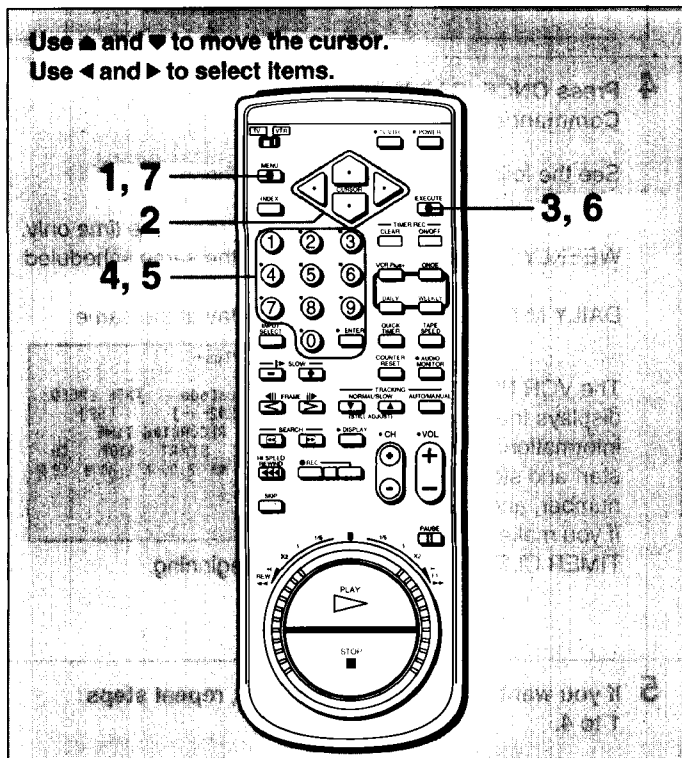

Use ▲ and ▼ to move the cursor.  
Use ◀ and ▶ to select items.

**1 Press MENU.**  
The main MENU appears.

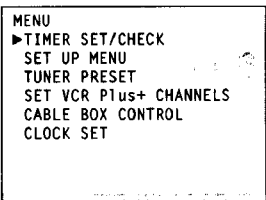

**2 Press ▼ or ▲ to move the cursor (▶) to SET VCR Plus+ CHANNELS.**

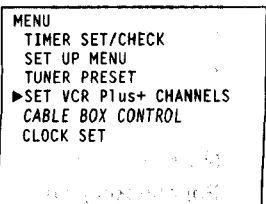

**3 Press EXECUTE.**  
The SET VCR Plus+ CHANNELS menu appears. The "GUIDE CH" field blinks.

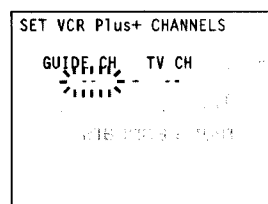

**4 In the "GUIDE CH" field, enter 33 (the number assigned to this channel in the Channel Line-Up Chart) and press ENTER.**  
The "TV CH" field blinks.

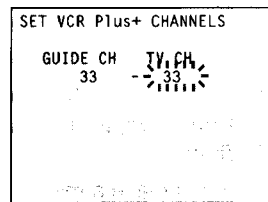

**5 In the "TV CH" field, enter 15 (the number to which you tune your VCR to watch this channel) and press ENTER.**

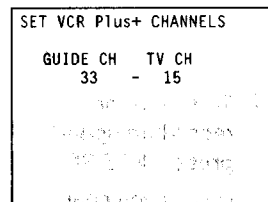

**NOTE:**  
The TV Channel setting will be different whether you use cable TV or not. Please refer to "Preparation" on page 6.

**6 For each channel in which the TV channel differs from the guide number, repeat steps 4 and 5, using the menus that are displayed.**  
To check your channel settings, press EXECUTE.

VCR Plus+ CHANNEL LIST			
page 1			
GUIDE	TV	GUIDE	TV
2	- 73	59	- 47
5	- 4	61	- 3
17	- 55	77	- 35
28	- 9	86	- 120
43	- 118	90	- 22

Use ◀ ▶ to change page  
Push MENU to quit

**7 When you've finished, press MENU to exit.**

## Recording Programs Using VCR Plus+

To use VCR Plus+ to record programs, all you need is the program's PlusCode, which you'll find in the program listings in your local newspaper, cable TV guide, or *TV Guide* magazine.

For example, to record the following program, just use the following procedures:

PlusCode

EXAMPLE: **18** MOVIE---Comedy (2hrs.) **53292**

### NOTE:

- You can set the program without opening the VCR Plus+ menu. Refer to the display window on the VCR.
- When you use a cable box, use Hookup 2 and set the CABLE BOX CONTROL (See "Setting the Cable Box Control" on page 23). Turn the cable box on.

### 1 Press VCR Plus+.

The VCR Plus+ TIMER SET menu appears.

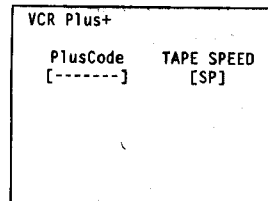

### 2 Enter 53292 (the program's PlusCode) in the PlusCode field.

If you make a mistake, press TIMER CLEAR and enter the PlusCode again.

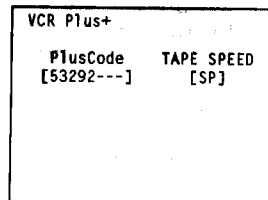

### 3 To select the cassette's recording speed (SP or EP), press TAPE SPEED.

Unless you change the cassette speed, SP is used. See "Maximum recording time of a cassette" on page 27 for information about cassette speeds.

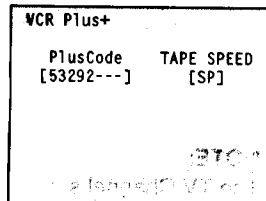

### 4 Press ONCE, DAILY, or WEEKLY on the Remote Commander.

See the following chart for details of these options.

**ONCE:** Records scheduled programs one time only.  
**WEEKLY:** Records every week at the same scheduled time.

**DAILY M-F:** Records Monday to Friday at the same scheduled time.

The VCR Plus+ menu displays the recording information: date, program start and stop times, channel number, and tape speed.

If you make a mistake, press TIMER CLEAR, and start from the beginning.

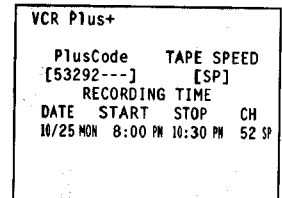

### 5 If you want to set another program, repeat steps 1 to 4.

### 6 Insert a cassette into your VCR.

### 7 Press TIMER REC (ON/OFF) to set the VCR's recording timer.

The VCR enters the timer recording standby mode. Your VCR is now set up to record the programs you've selected. The VCR will turn on automatically, record the program, and then turn off until the next programmed show is ready for broadcast.

For checking, changing, and cancelling the settings, see pages 39 and 40.

Leave the cable box on.

**NOTES:**

You can't set the timer using PlusCodes in the following cases:

- When the VCR is turned off
- While the VCR is in the timer-recording or quick-timer recording mode
- When the VCR is in the timer-recording standby mode

The timer will not accept settings in the following cases:

- When you select DAILY for a Saturday and Sunday program
- When you select WEEKLY or DAILY for a program more than seven days ahead. (The WEEKLY and DAILY settings only work for the current week.)
- When you enter the PlusCode of a program that has already ended

# Variable Speed Playback

The following section explains the advanced playback functions you can do with your VCR.

## Variable Speed Playback

Using the DUAL MODE SHUTTLE ring on your VCR or Remote Commander, you can play cassettes at a variety of forward and reverse speeds. You can also freeze a picture using the pause function.

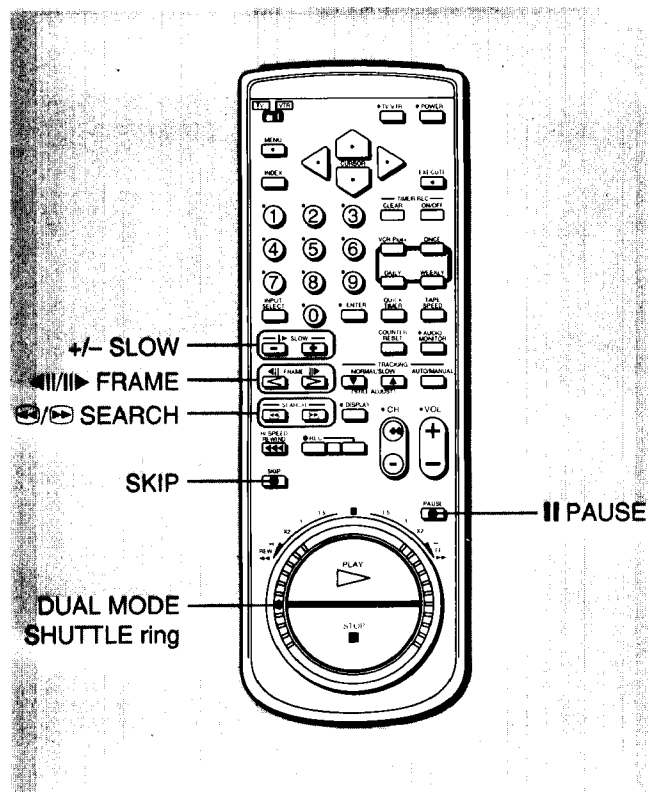

## Still Picture

When playing back a cassette, press **II PAUSE** to hold the picture in one place. To resume normal playback, press either **▶ PLAY** or **II PAUSE**. If you leave your VCR in the pause mode, normal playback resumes after approximately 5 minutes.

## Picture Search

By turning the DUAL MODE SHUTTLE ring either clockwise for forward viewing or counterclockwise for viewing in reverse, you can control the cassette playback speed.

- **Picture Search During Playback or Pause Modes** While playing or pausing a cassette, turn the DUAL MODE SHUTTLE ring until one of the double arrow indicators **◀◀** (left side) or **▶▶** (right side) lights up. A high-speed picture without sound displays on the screen until you release the ring.

When you release the DUAL MODE SHUTTLE ring, it returns to its original position. If you release the ring while in the pause mode, the picture returns to pause. If you release it during playback, the picture returns to playback.

### NOTE:

If you quick search a cassette recorded in the LP cassette speed, your picture may change to black and white, depending on the TV you're using.

- **Picture Search While Fast-Forwarding or Rewinding a Cassette**

When fast-forwarding or rewinding a cassette, turn the DUAL MODE SHUTTLE ring to preview a high-speed picture (clockwise for forward viewing or counterclockwise for reverse viewing).

When you release the ring, it returns to its original position and the VCR continues fast-forwarding or rewinding.

### Locked Picture Search

This feature lets you lock in and view a high-speed picture while playing or pausing a cassette. In the play or pause mode, press **SEARCH** (reverse) or **SEARCH** (forward) on the Remote Commander. To resume normal playback, press **PLAY**.

### Skip Playback

While playing a cassette, press **SKIP** on the Remote Commander.

This feature lets you view your cassette at high speed for about 30 seconds before resuming normal playback.

### Slow Motion Playback

During playback or playback pause mode, press **SLOW +** or **-** on the Remote Commander. Change the slow motion speed with the **+** or **-** buttons.

Press **+** to increase the playback speed, and **-** to decrease the playback speed.

### Frame-by-Frame Picture

During the playback pause mode, press **FRAME** **||>** **>** to advance the picture one frame or **FRAME** **||<** **<** to reverse the picture one frame.

Each time you press the button, the picture moves one frame. To resume normal playback, press **PLAY**.

### Picture Adjustment During Variable Speed Playback

If a picture played in slow motion displays streaks or has poor sound quality, adjust the picture with the **TRACKING NORMAL/SLOW** and **STILL ADJUST** **▼/▲** buttons on the Remote Commander. You can adjust the picture more easily by changing the speed closer to normal playback by pressing **SLOW +**.

If the picture appears to shake in the still mode, adjust it using the **STILL ADJUST** **▼/▲** buttons on the Remote Commander until the picture stabilizes.

When pausing a cassette, you may notice a band at the top or bottom of the screen. Adjust the picture by playing back the cassette in slow motion and using the **TRACKING NORMAL/SLOW** and **STILL ADJUST** **▼/▲** buttons on the Remote Commander.

#### NOTE:

Some streaks and/or snow are unavoidable when playing back a cassette in the reverse or reverse slow modes.

# Index Function

You can find specific locations on a cassette using your VCR's index function.

## Index Signals

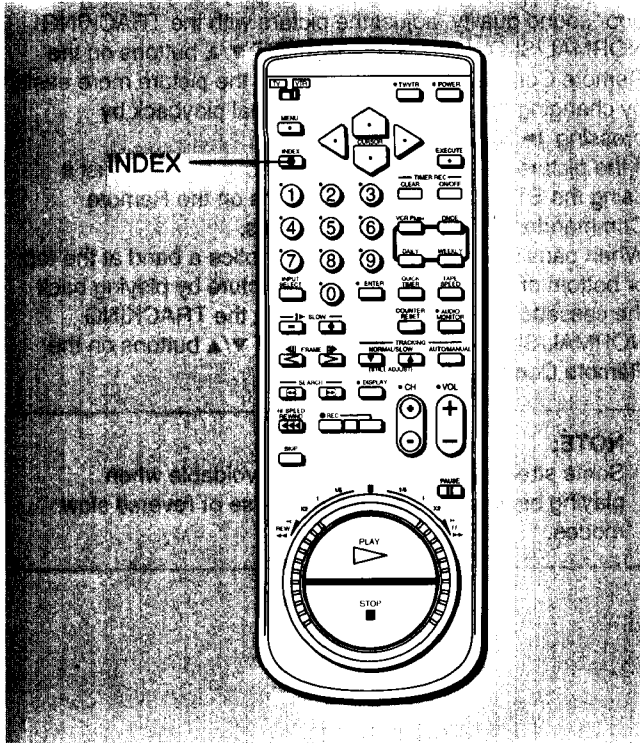

The VCR automatically inserts index signals each time you use the recording, timer recording or quick-timer recording functions (index mark). When an index mark is made, INDEX MARK appears on the TV screen. The index works as a divider between scenes, and is not numbers. So, when you specify the index mark later, you have to specify the relative position from the current position (the first index, the second index... from the current position). When going from the recording pause mode to the recording mode, an index is not inserted.

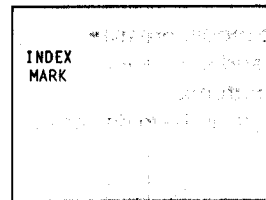



## Playing Back from the Index Point — Index Scan

Here's how to find and play a program you've marked with an index signal:

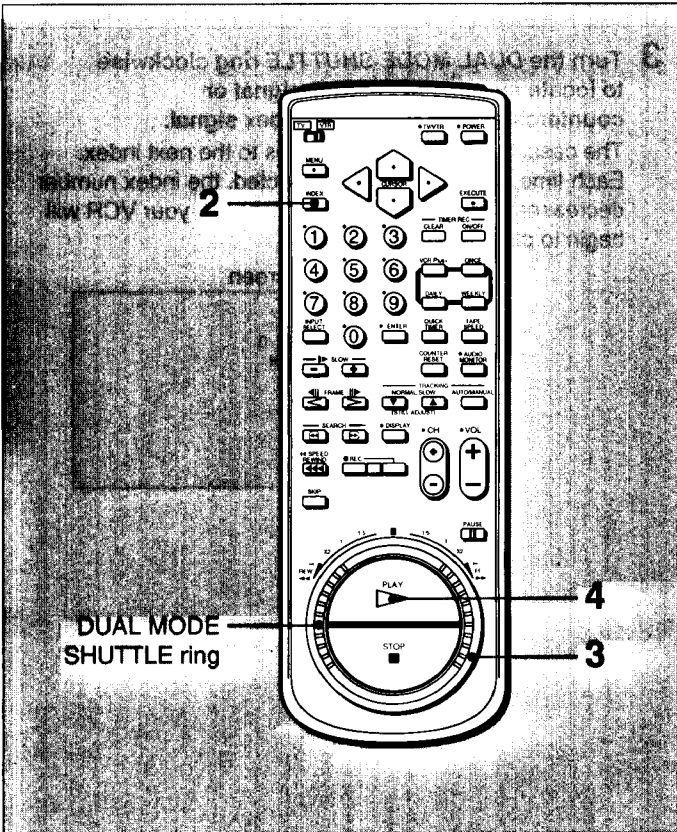

- 3 Turn the DUAL MODE SHUTTLE ring clockwise to find the previous program, or counter clockwise to find the next program.**  
 The index scan locates the next marked index signal and plays about 10 seconds of tape prior to the signal. The VCR then rewinds or advances to the next index signal. Every time the VCR finds an index signal, playback begins and the displayed index number increases.

TV screen

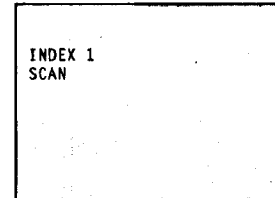

- 1 Insert an indexed cassette into your VCR.**

- 4 When you find the program you want, press ► PLAY.**  
 Playback starts from that point.

- 2 Press INDEX once.**  
 The INDEX SCAN indicator appears on the TV screen.

TV screen

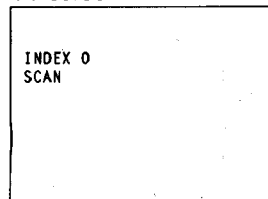

## Locating an Index — Index Search

Locate an index by indicating how many index signals ahead or behind that program is from the cassette's current position. Here's how:

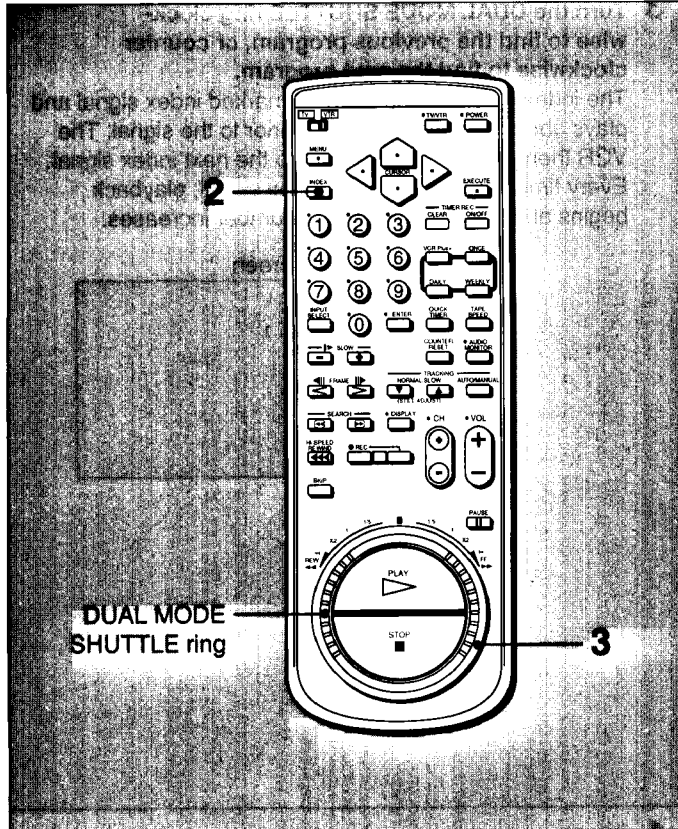

- 3 Turn the DUAL MODE SHUTTLE ring clockwise to locate an upcoming Index signal or counterclockwise for a prior index signal.** The cassette rewinds or advances to the next index. Each time an index signal is detected, the index number decreases. When the number reaches 0, your VCR will begin to play.

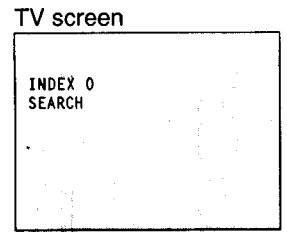

- 1 Insert an indexed cassette into your VCR.**

- 2 Press INDEX until the index number for the desired program appears on your TV screen.** The VCR exits from the index mode, if you pass index number 19.

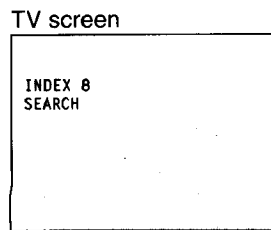

# APC (Adaptive Picture Control)

This function automatically improves recording and playback quality by adjusting the VCR for the condition of the video heads and video tape. To maintain better picture quality, we recommend that you leave the function on. (The APC button/indicator remains lit.)

## Using the APC Function when Recording

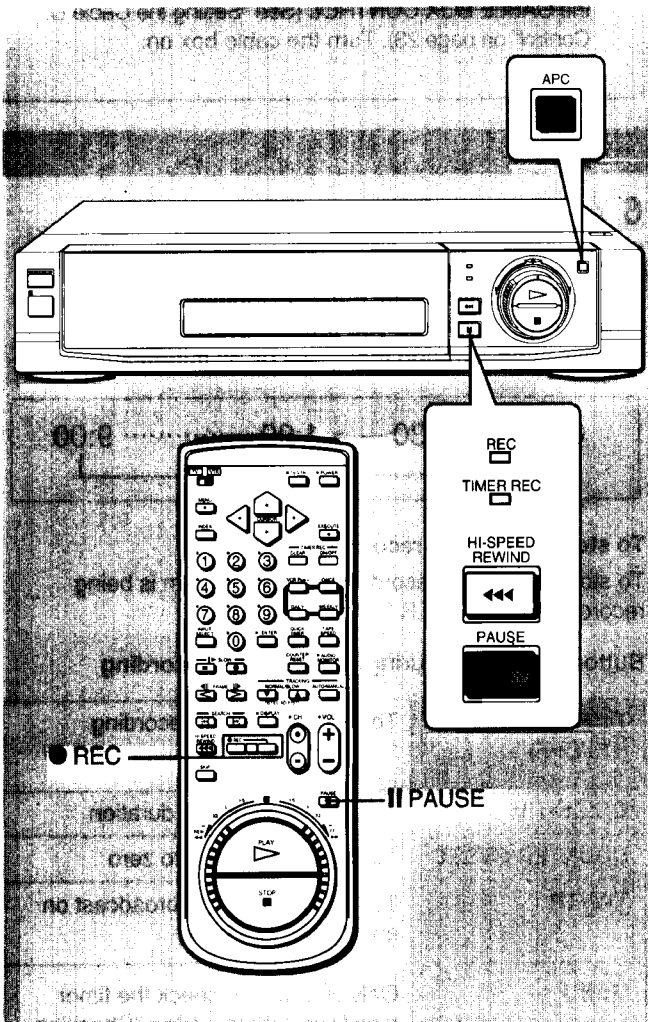

Before you start recording, make sure the APC button/indicator is lit. If it is not, press the APC button/indicator so that it lights up.

The light flashes rapidly while the tape is being measured. The complete measurement is retained until the cassette is ejected. If you use that same tape again without ejecting it, the tape is not measured again.

### When you are in the recording pause mode and the APC button/indicator flashes slowly

The APC function does not operate if you press **II PAUSE** to release the pause mode.

To use the APC function, press **● REC**. After measurement is completed, the VCR returns to the recording pause mode. Press **II PAUSE** to start recording.

### When you are using timer recording

When you want to use the APC function during timer recording, press the APC button/indicator so that it lights up, then press the **TIMER REC** button.

## Using the APC Function when Playing Back a Tape

When the APC button/indicator is on, the APC function automatically works on all types of tapes, including rental tapes. You can play back a tape using the APC function even if the tape was not recorded with it.

### Notes:

- Tapes recorded using the APC function are played back normally on VCRs that do not have the APC function.
- If you have the PICTURE switch on the VCR set to EDIT, the APC function does not operate when playing back a tape but does operate when recording.

# Quick-Timer Recording

This function allows you to preset your VCR to record for a specified amount of time from now, without having to set the recording start time.

## NOTE:

- Before you begin, make sure the clock has been set, then ensure that the timer recording function is turned off by checking the **TIMER REC** (recording) indicator. If the indicator is lit, press **TIMER REC ON/OFF** to turn it off.
- When you use a Cable Box, use Hookup 2 and set the **CABLE BOX CONTROL** (See "Setting the Cable Box Control" on page 23). Turn the cable box on.

## Quick-Timer Recording

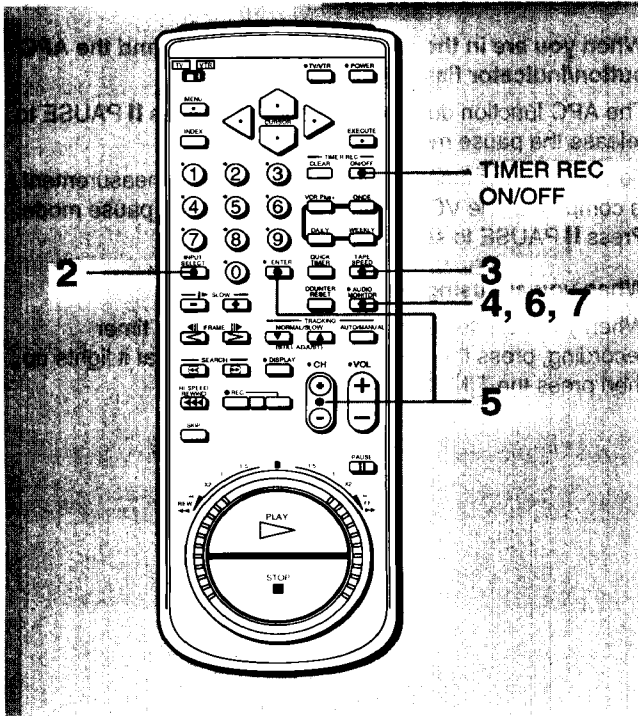

If you're currently recording, skip to step 7.

- 1** Insert a cassette into your VCR.
- 2** Press **INPUT SELECT** to select the input you want, which will then light up in the display window.
- 3** Select the desired recording speed (SP or EP) by pressing **TAPE SPEED**.
- 4** Press **QUICK TIMER**.  
If you insert a cassette without its safety tab, your VCR will eject the cassette.
- 5** When you want to record a TV program, select the channel you wish to record using the **CH +/-** or channel number buttons. Press **ENTER** while the channel display flashes.

**6** Press **QUICK TIMER** again to start recording.

**7** Select the recording duration by pressing **QUICK TIMER** to change the duration indicator in the display window. Each time you press **QUICK TIMER**, the recording duration increases by 30 minutes.

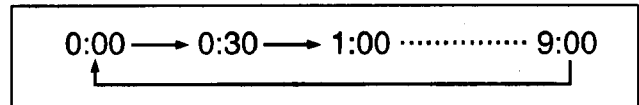

### To stop quick-timer recording

To stop quick-timer recording while a program is being recorded, press **TIMER REC ON/OFF**.

### Buttons Operable During Quick-Timer Recording

<b>TIMER REC (ON/OFF)</b>	To stop quick-timer recording
<b>QUICK-TIMER</b>	To change recording duration
<b>COUNTER RESET</b>	To reset the counter to zero
<b>TV/VTR</b>	To watch the picture broadcast on another channel (TV)
<b>MENU</b>	Only operable to check the timer recording settings. (See "Checking the Timer Settings," on page 39.)

## NOTES:

- If your cassette ends during quick-timer recording, recording stops and the VCR turns off. The cassette will not rewind automatically.
- If a power interruption occurs during quick-timer recording, recording will stop and your VCR will turn off. If the interruption lasts less than three hours and the power is restored before the recording end time, recording will start again from that point.

Using an additional VCR, you can record programs from one VCR to the other. Here's how:

## Editing from Another VCR

Here's how to edit from another VCR (such as an 8mm video camera recorder for playback) when using this VCR for recording.

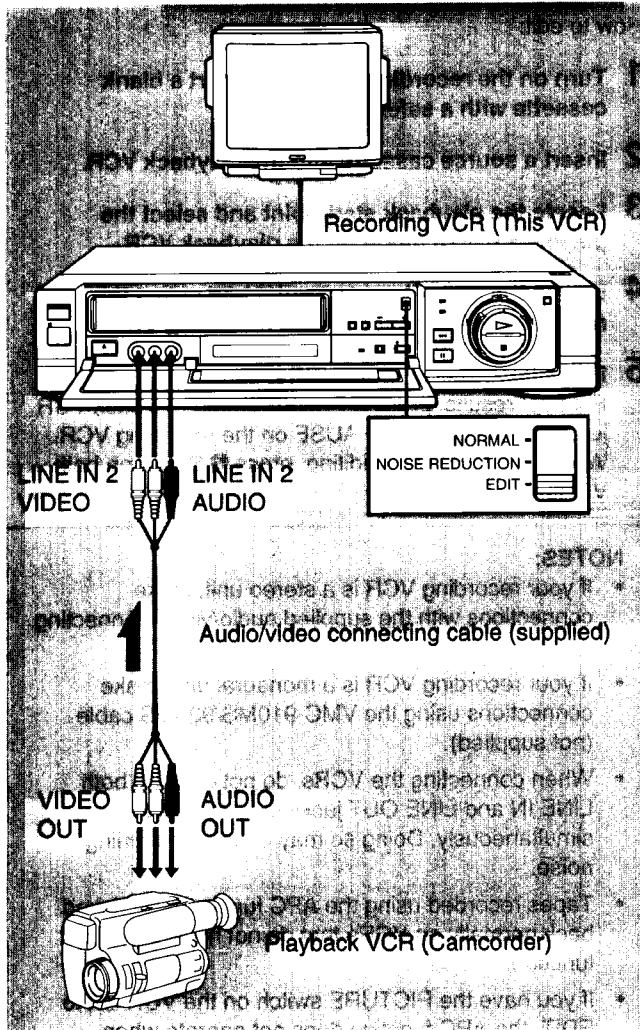

### Before you start:

- Select LINE 1 or LINE 2 with INPUT SELECT, whichever the playback VCR is connected to.
- Select SP or EP with TAPE SPEED.
- Select the EDIT picture on the PICTURE switch.

### NOTE:

If your playback VCR has an editing function, select it to reduce static and improve reception.

### How to edit:

- 1** Insert a blank cassette into the recording VCR with a safety tab in place.
- 2** Turn on the playback VCR and insert a source cassette.
- 3** Locate the playback start point and select the playback pause mode on the playback VCR.
- 4** Locate the recording start point and select the recording pause mode on the recording VCR.
- 5** Press **II PAUSE** on both VCRs.

For best results, press **II PAUSE** on the playback VCR just before pressing **II PAUSE** on the recording VCR. When you've finished editing, press **■ STOP** on both VCRs.

When you release the recording pause mode, the APC function may not operate.

For details, see page 51.

### NOTES:

- If your playback VCR is a stereo unit, make connections with the supplied audio/video connecting cable.
- If your playback VCR is a monaural unit, connect the white plug to LINE IN 2 AUDIO L on this VCR. This lets you record the sound of the playback VCR on both channels of this VCR. Do not connect the white plug to LINE IN 2 AUDIO R.
- When connecting the VCRs, do not connect both LINE IN and LINE OUT jacks on your VCRs simultaneously. Doing so may cause a humming noise.
- Tapes recorded using the APC function are played back normally on VCRs that do not have the APC function.
- If you have the PICTURE switch on the VCR set to EDIT, the APC function does not operate when playing back a tape but does operate when recording. When you are editing tapes (dubbing) using this unit as either the recording VCR or the playback VCR, use the EDIT setting.

## Editing onto Another VCR

Here's how to use this VCR as the playback VCR and another VCR as the recording VCR.

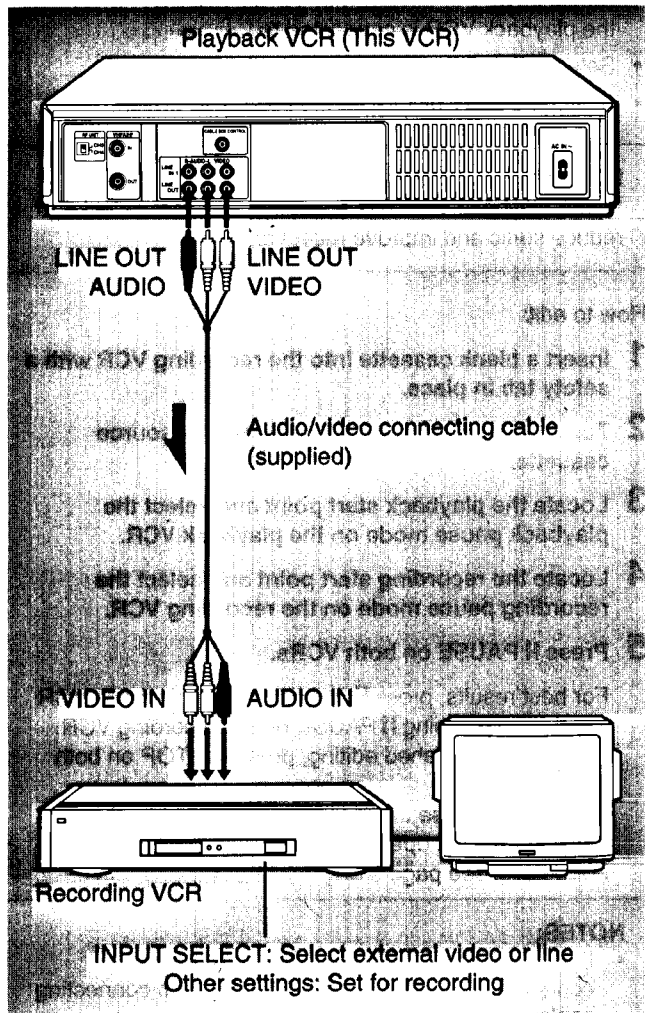

Before you start:

- Select the **EDIT** position on the **PICTURE** switch. If your recording VCR has an editing function, it should also be selected to improve reception.
- Press **DISPLAY** to **TURN OFF** the display.

How to edit:

- 1 Turn on the recording VCR and insert a blank cassette with a safety tab in place.
- 2 Insert a source cassette into the playback VCR.
- 3 Locate the playback start point and select the playback pause mode on the playback VCR.
- 4 Locate the recording start point and select the recording pause mode on the recording VCR.
- 5 Press **II PAUSE** on both VCRs. For best results, press **II PAUSE** on the playback VCR just before pressing **II PAUSE** on the recording VCR. When you've finished editing, press **■ STOP** on both VCRs.

### NOTES:

- If your recording VCR is a stereo unit, make connections with the supplied audio/video connecting cable.
- If your recording VCR is a monaural unit, make connections using the VMC-910MS/920MS cable (not supplied).
- When connecting the VCRs, do not connect both **LINE IN** and **LINE OUT** jacks on your VCRs simultaneously. Doing so may cause a humming noise.
- Tapes recorded using the APC function are played back normally on VCRs that do not have the APC function.
- If you have the **PICTURE** switch on the VCR set to **EDIT**, the APC function does not operate when playing back a tape but does operate when recording. When you are editing tapes (dubbing) using this unit as either the recording VCR or the playback VCR, use the **EDIT** setting.

# General Setup Information

## Setting the RF UNIT

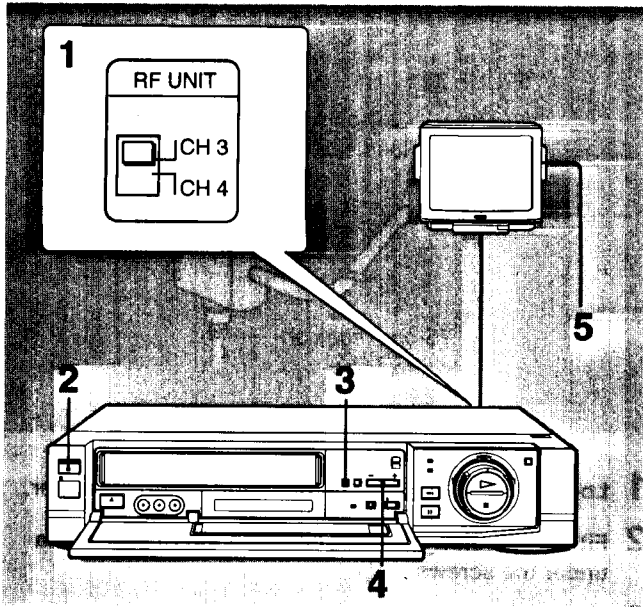

### Why this setting is necessary:

You must set the RF UNIT selector at the rear of the VCR properly so that your TV can receive the correct signal from the VCR. Set the selector to CH 3 (channel 3) or CH 4 (channel 4), whichever is not active in your area.

If you connect a TV or color monitor equipped with A/V input jacks, skip this step.

- 1 Set the RF UNIT at the rear of the VCR to CH 3 or CH 4, whichever is not active in your area.**
- 2 Press POWER.**  
The power indicator lights up on the VCR.
- 3 Press TV/VTR.**  
The VTR indicator lights up in the display window.
- 4 Select an active channel in your area by pressing CHANNEL +/-.**
- 5 Turn on your TV and set it to the channel you selected in step 1.**

Your TV is now tuned to the VCR. Whenever you use the VCR, set the TV to the preselected channel.

### NOTE:

For details on adjusting TV channels, see your TV instruction manual.

## Attaching the External Antenna Connector (supplied)

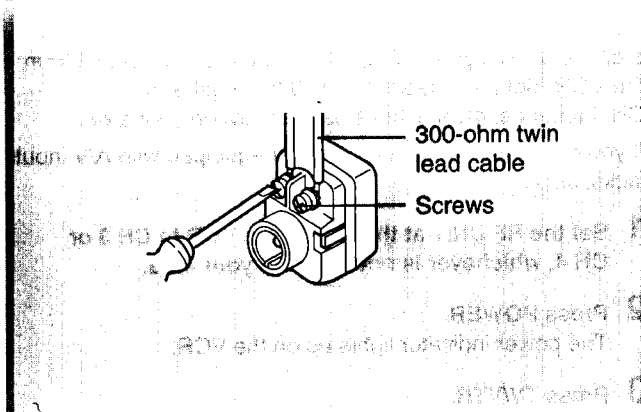

- 1 Loosen the screws on the antenna connector.
- 2 Fit the 300-ohm twin lead cable on the UHF antenna under the screws on the antenna connector.
- 3 Retighten the screws.

## Attaching the EAC66 U/V Band Separator / Mixer (not supplied)

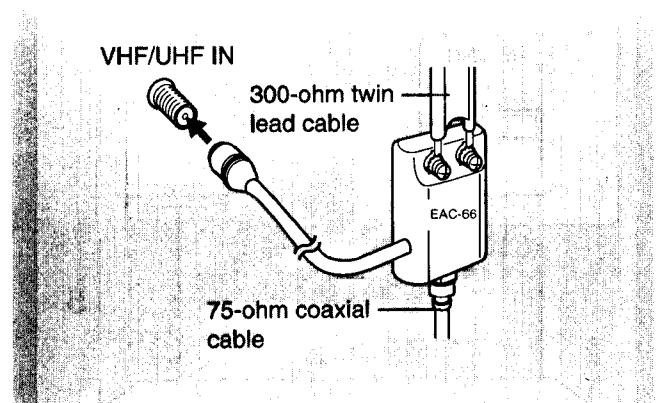

- 1 Loosen the screws on the U/V band separator/mixer.
- 2 Fit the 300-ohm twin lead cable on the UHF antenna under the screws.
- 3 Connect the 75-ohm coaxial cable to the U/V band separator/mixer.
- 4 Connect the U/V band separator/mixer to the VHF/UHF IN plug on the VCR.



# Identifying the Parts and Controls

Refer to the pages indicated for details.

## Front Panel

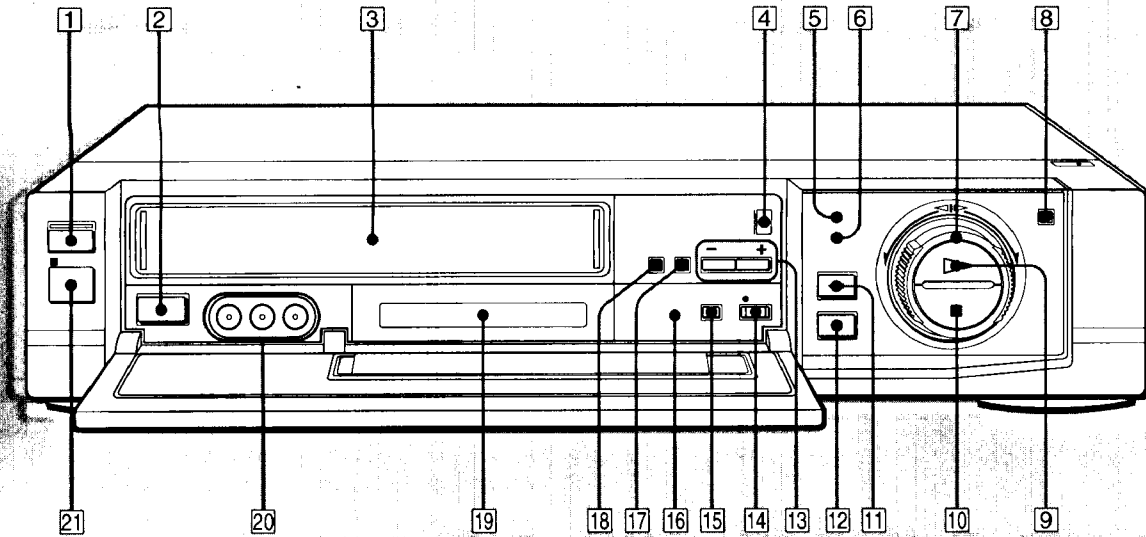

- 1 POWER ON/OFF switch and indicator (See page 55.)
- 2 ▲ EJECT button (See page 27.)
- 3 Cassette compartment (See page 27.)
- 4 PICTURE switch (See page 28.)
- 5 REC indicator (See page 32.)
- 6 TIMER REC indicator (See page 36.)
- 7 DUAL MODE SHUTTLE ring (See page 46.)
- 8 APC button/indicator (See page 51.)
- 9 ► PLAY button (See page 28.)
- 10 ■ STOP button (See pages 28 to 32.)
- 11 ◀◀◀ HI-SPEED REWIND button (See page 28.)
- 12 || PAUSE button (See pages 28 & 32 & 46.)
- 13 CHANNEL -/+ buttons (See page 32.)
- 14 ● REC button (See page 32.)
- 15 TIMER REC ON/OFF button (See page 36.)
- 16 STEREO indicator (See page 30.)
- 17 INPUT SELECT button (See page 32.)
- 18 TV/VTR button (See page 16.)
- 19 Display window (See page 59.)
- 20 LINE IN 2 VIDEO/AUDIO jacks (See page 53.)
- 21 Remote sensor (See page 16.)

# Identifying the Parts and Controls

Refer to the pages indicated for details.

## Rear Panel

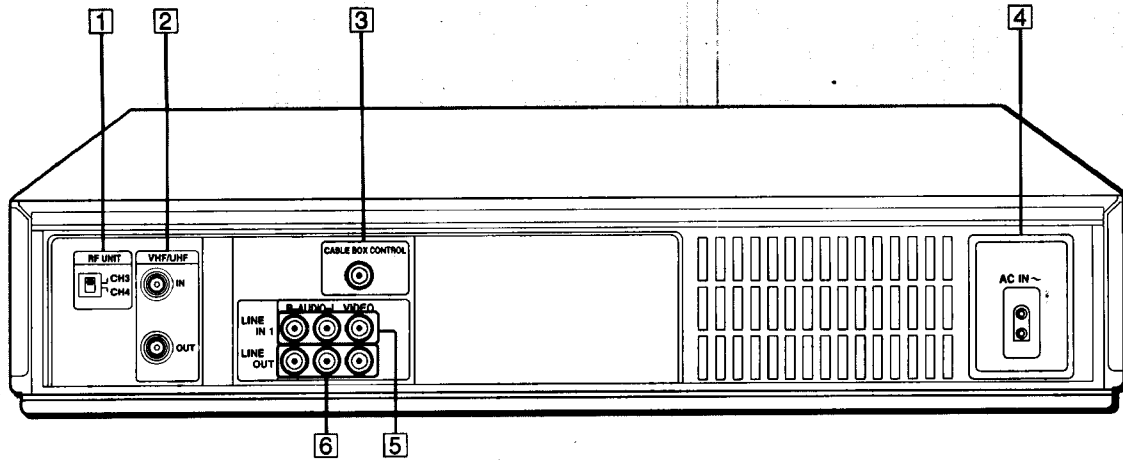

- 1 RF UNIT selector (See page 55.)
- 2 VHF/UHF IN/OUT connectors (F-type) (See pages 12 to 15.)
- 3 CABLE BOX CONTROL jack (See page 8.)
- 4 AC IN socket (See page 6.)
- 5 LINE IN 1 AUDIO and VIDEO jacks (phono type)
- 6 LINE OUT AUDIO and VIDEO jacks (phono type) (See page 7.)

Refer to the pages indicated for details.

### Display Window Indicators

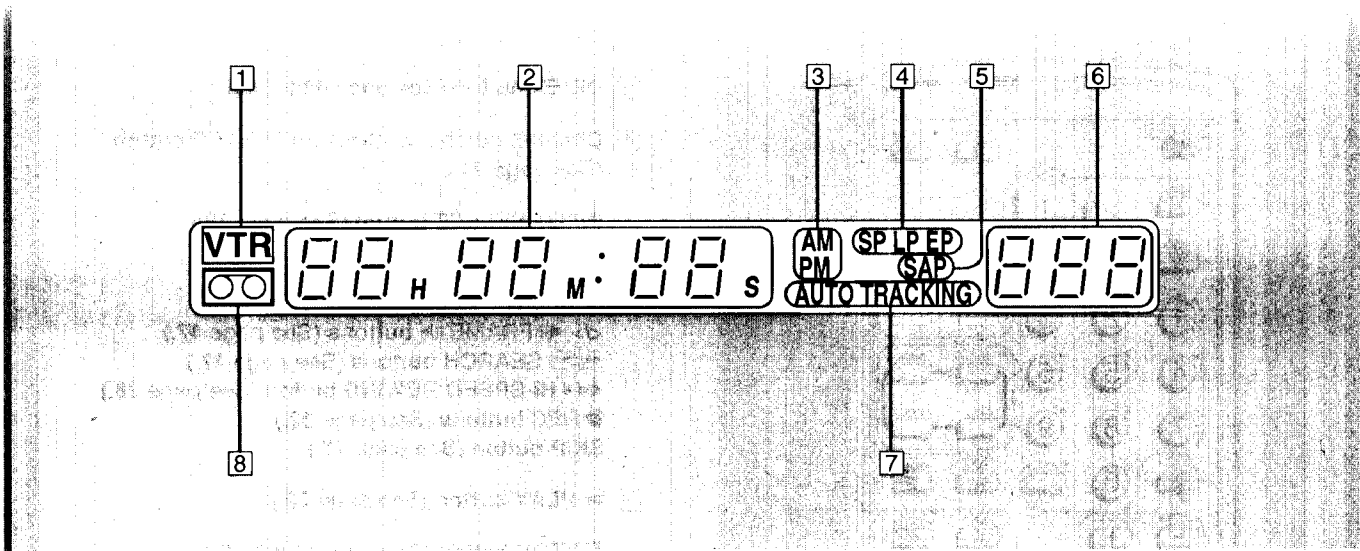

- 1 VTR indicator (See page 32.)
- 2 Linear time counter and clock (See page 29.)
- 3 AM/PM indicator
- 4 Tape speed indicator (See page 32.)
- 5 SAP (See page 34.)
- 6 Line and channel indicator
- 7 AUTO TRACKING indicator (See page 30.)
- 8 Cassette Indicator (appears when a cassette is loaded) (See page 27.)

# Identifying the Parts and Controls

Refer to the pages indicated for details.

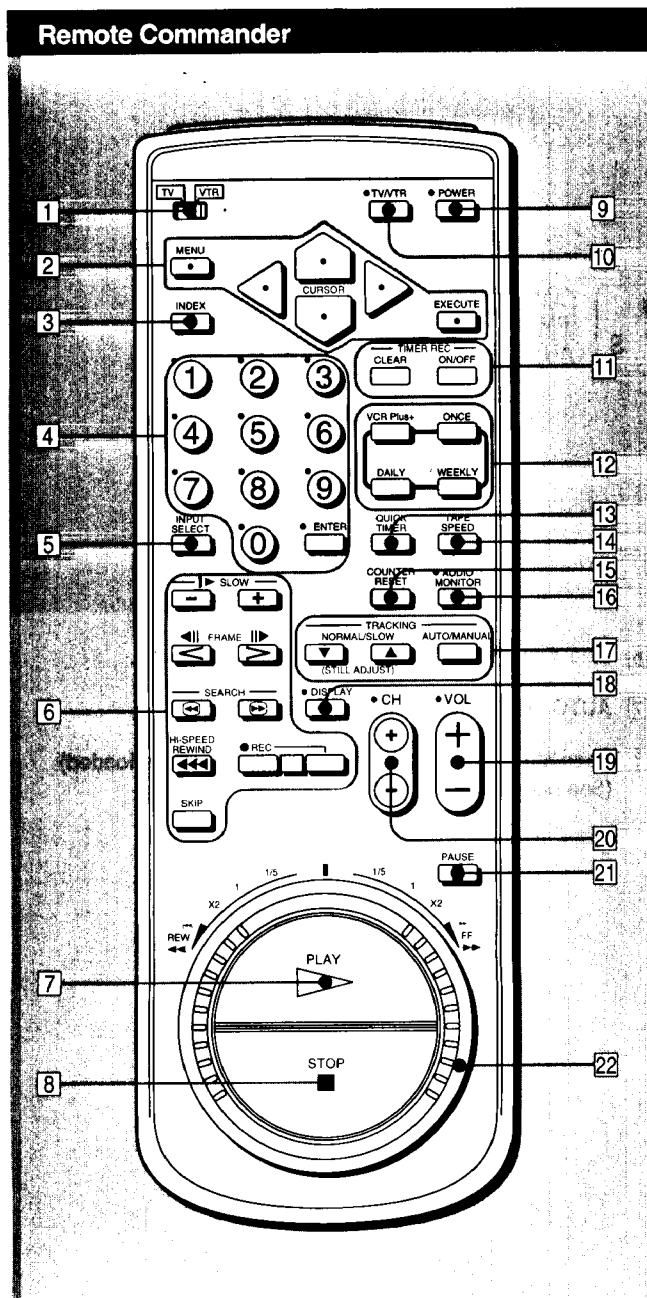

- 1 | **TV/VTR** remote control selector (See page 16.)
- 2 | **Menu operations buttons** (See pages 17 and 18.)  
**MENU** button  
**Cursor buttons** (▲ / ▼ / ◀ / ▶)  
**EXECUTE** button
- 3 | **INDEX** button (See page 48.)
- 4 | **Channel number buttons and ENTER** button (See page 24.)
- 5 | **INPUT SELECT** button (See page 32.)
- 6 | **Tape transport buttons**  
**▶ SLOW -/+** buttons (See page 47.)  
**◀▶ || FRAME || ▶▶** buttons (See page 47.)  
**◀▶ / ▶▶** **SEARCH** buttons (See page 47.)  
**◀◀◀ HI-SPEED REWIND** button (See page 28.)  
**● REC** buttons (See page 32.)  
**SKIP** button (See page 47.)
- 7 | **▶ PLAY** button (See page 28.)
- 8 | **■ STOP** button (See pages 28 & 32.)
- 9 | **POWER** button (See page 55.)
- 10 | **TV/VTR** button (See page 16.)
- 11 | **TIMER REC** buttons (See page 40.)  
**CLEAR** button  
**ON/OFF** button
- 12 | **VCR Plus+** buttons (See page 44.)  
**VCR Plus+** button  
**ONCE** button  
**DAILY** button  
**WEEKLY** button
- 13 | **QUICK TIMER** button (See page 52.)
- 14 | **TAPE SPEED** button (See page 36.)
- 15 | **COUNTER RESET** button (See page 29.)
- 16 | **AUDIO MONITOR** button (See page 30.)
- 17 | **TRACKING** buttons (See pages 30 & 47.)  
**▼/▲ NORMAL/SLOW (STILL ADJUST)** buttons  
**AUTO/MANUAL** button
- 18 | **DISPLAY** button (See page 29.)
- 19 | **VOL (volume)** button
- 20 | **CH (channel)** button
- 21 | **PAUSE** button (See pages 28 & 32 & 46.)
- 22 | **DUAL MODE SHUTTLE** ring (See pages 28 & 46.)

# Troubleshooting

If you have a problem with your VCR, first check the power cord connection, then go through the following list. Should the difficulty persist, unplug the unit, and contact your Sony dealer or local authorized Sony Service Center facility.

	Symptom	Possible causes and remedies
<b>Power</b>	The POWER switch doesn't work.	<ul style="list-style-type: none"> <li>• The power cord is disconnected.</li> <li>• The VCR is in the timer standby mode.</li> </ul>
	The power is turned on but the VCR doesn't work.	<ul style="list-style-type: none"> <li>• The safety device on the VCR has switched on. Turn the power off, disconnect the power cord from the wall outlet, and let the VCR rest for at least an hour before trying it again.</li> </ul>
<b>Time and Date Clock</b>	The clock has stopped and "--:--" lights up.	<ul style="list-style-type: none"> <li>• There has been a power interruption. Reset the time, date and timer settings.</li> </ul>
<b>TV Reception</b>	TV reception is poor.	<ul style="list-style-type: none"> <li>• The channel for the VCR is not correctly tuned on the TV.</li> <li>• The TV signal is weak. Adjust the direction of the antenna.</li> <li>• The AC power cord of the VCR is disconnected.</li> </ul>
<b>Recording and Playback</b>	Shaky and/or snowy picture during recording.	<ul style="list-style-type: none"> <li>• The TV's channel is not set to the one preset for the VCR.</li> <li>• The TV signal is weak. Adjust the direction of the antenna.</li> </ul>
	No picture on the TV screen.	<ul style="list-style-type: none"> <li>• Press TV/VTR so that the VTR indication appears in the display window.</li> <li>• The TV channel is not set to CH 3 or CH 4, or the video input has not been selected on the TV or monitor.</li> </ul>
	The VCR won't record.	<ul style="list-style-type: none"> <li>• No cassette has been inserted.</li> <li>• The cassette is at its end.</li> <li>• INPUT SELECT is not set correctly.</li> </ul>
	The playback picture is not clear.	<ul style="list-style-type: none"> <li>• The channel for the VCR is not correctly tuned on the TV.</li> <li>• A cassette recorded on another VCR is being played back. Adjust the tracking with the TRACKING NORMAL/SLOW and STILL ADJUST.</li> <li>• The video heads are dirty. Clean the heads using the Sony T-25CL video head cleaning cassette. For details on cleaning, refer to the instructions furnished with the cleaning cassette. If a cleaning cassette is not available in your area, have the heads cleaned at your nearest Sony Service Center facility. (Do not use a commercially-available wet-type cleaning cassette. It may damage the video heads.)</li> <li>• The video heads are worn out.</li> </ul>

# Troubleshooting

	Symptom	Possible causes and remedies
<b>Recording and Playback</b>	The picture moves vertically during picture search mode.	<ul style="list-style-type: none"> <li>Adjust the vertical hold control on the TV or color monitor.</li> </ul>
	The sound drops out.	<ul style="list-style-type: none"> <li>The cassette is defective. Use a new video cassette.</li> </ul>
	Stereo recording cannot be made.	<ul style="list-style-type: none"> <li>AUTO STEREO is set to "OFF" in the SET UP MENU.</li> </ul>
	Both main and SAP sounds are heard when playing back a cassette on which an MTS broadcast was recorded.	<ul style="list-style-type: none"> <li>AUDIO MIX is set to "ON" in the SET UP MENU.</li> </ul>
	No sound is recorded on the normal audio track.	<ul style="list-style-type: none"> <li>NORMAL AUDIO is set to "SAP" in the SET UP MENU when there is no SAP broadcast.</li> </ul>
<b>Timer Recording</b>	Timer setting cannot be made.	<ul style="list-style-type: none"> <li>The current time has not been preset.</li> </ul>
	The TIMER REC (recording) indicator is not lit even though you've pressed TIMER REC (ON/OFF).	<ul style="list-style-type: none"> <li>No cassette has been inserted.</li> <li>The cassette is at its end.</li> <li>No setting for timer-recording has been made.</li> </ul>
	The cassette is ejected when you press TIMER REC (ON/OFF).	<ul style="list-style-type: none"> <li>The safety tab of the cassette has been removed.</li> </ul>
	Timer recording was not made.	<ul style="list-style-type: none"> <li>There has been a power interruption of one hour or more.</li> <li>TIMER REC (ON/OFF) was not pressed.</li> <li>CABLE BOX CONTROL setup was not done or was done incorrectly.</li> <li>The cable box was not turned on when recording started.</li> <li>The cable box is not receiving the control signal from the VCR. Reposition the cable box away from the VCR. Make sure that the Cable Mouse is attached as shown on page 8.</li> </ul>
<b>Display</b>	The display does not appear on the screen.	<ul style="list-style-type: none"> <li>Press DISPLAY.</li> </ul>
<b>Others</b>	Cassette cannot be inserted.	<ul style="list-style-type: none"> <li>A cassette has already been inserted.</li> </ul>
	The Remote Commander cannot be operated.	<ul style="list-style-type: none"> <li>The batteries are low.</li> </ul>
	The channels on the VCR cannot be changed.	<ul style="list-style-type: none"> <li>The recording condition of the cassette is very poor and tracking cannot be adjusted.</li> <li>The CABLE BOX CONTROL is set to "ON." Set the CABLE BOX CONTROL to "OFF."</li> </ul>

# Specifications

## System

<b>Format</b>	VHS NTSC standard
<b>Video Recording System</b>	Rotary two-head helical scanning FM system
<b>Video Signal</b>	NTSC color, EIA standards
<b>Tape Speed</b>	SP: 33.35 mm/s (1 3/8 inches/s) EP: 11.11 mm/s (7/16 inches/s) LP: 16.67 mm/s (11/16 inches/s) Playback only
<b>Maximum recording/ playback time</b>	9 hrs. in EP mode (with T-180 tape)
<b>Fast-forward and rewind time</b>	Approx. 4 min. 30 sec (with T-120 tape)
<b>High-speed rewind time</b>	Approx. 3 min. (with T-120 tape)

## Tuner Section

<b>Channel Coverage</b>	VHF channels 2 to 13 UHF channels 14 to 69 CATV channel
<b>Antenna</b>	A-8 to A-1, A to W, W+1 to W+84 75-ohm antenna terminal for VHF/UHF

## Inputs and Outputs

<b>LINE IN 1 and 2</b>	VIDEO IN (phono jack) (1 each) Input signal: 1 Vp-p, 75 ohms, unbalanced, sync negative AUDIO IN (phono jack) (2 each) Input level: -7.5 dBs (0 dBs = 0.775 Vrms) Input impedance: more than 47 kilohms
<b>LINE OUT</b>	VIDEO OUT (phono jack) (1) Output signal: 1 Vp-p, 75 ohms, unbalanced, sync negative AUDIO OUT (phono jack) (2) Standard output: -7.5 dBs at load impedance 47 kilohms Output impedance: less than 10 kilohms

## Timer Section

<b>Clock</b>	Quartz locked
<b>Time Indication</b>	12-hour cycle
<b>Timer Setting</b>	Only for recording 8 program in one month at max.
<b>Power back-up</b>	Built-in self-charging capacitor Back-up duration: Up to three hours at one time

## General

<b>Power requirements</b>	120 V AC, 60 Hz
<b>Power consumption</b>	25 W (max.)
<b>Operating temperature</b>	5°C to 40°C (41°F to 104°F)
<b>Storage temperature</b>	-20°C to 60°C (-4°F to 140°F)
<b>Dimensions</b>	430 x 90 x 372 mm (w/h/d) (17 x 3 5/8 x 14 3/4 inches)
<b>Weight</b>	5.2 kg (11 lb 7oz.)

## Remote Commander

<b>Remote control system</b>	Infrared control
<b>Power requirements</b>	3 V DC, 2 size AA batteries (IEC designation R6)

## Accessories Supplied

Remote Commander .....	(1)
Size AA (R6) batteries .....	(2)
75-ohm coaxial cable with F-type connectors .....	(1)
External antenna connector .....	(1)
AC power cord .....	(1)
Audio/video connecting cable (3 phono to 3 phono) .....	(1)
Cable Mouse (Cable Box Controller) .....	(1)

Design and specifications are subject to change without notice.

## A

Accessories supplied 63  
Active channels 19  
Adjusting  
    FINE TUNING (See "Fine Tuning.")  
    picture 21  
    sound 30  
    tracking (automatic, manual) 30  
AUDIO MIX mode 26  
AFT (Auto Fine Tuning) setting 21  
Antenna  
    hookup 14  
    VCR setup 15  
    VCR Plus+ channel setup 15  
APC (Adaptive Picture Control) 51  
AUDIO MIX 26, 31, 62  
AUDIO MONITOR 30, 31  
AUTO ANT SEL (Automatic Antenna Selector) 7, 26  
Audio/Video (A/V)  
    hookup 7  
AUTO STEREO 26, 62  
AUTO TRACKING indicator 30, 59

## B

Buttons  
    APC button 51  
    AUDIO MONITOR button 30, 31, 60  
    Channel +/- buttons 32, 55, 57, 60  
    Channel Number buttons 32, 60  
    COUNTER RESET button 29, 37, 52, 60  
    DAILY button 44, 60  
    DISPLAY button 29, 60  
    EJECT button 27, 57  
    EXECUTE button 60  
    FRAME button 47, 60  
    HI-SPEED REWIND button 28, 57  
    INDEX button 48, 52, 60  
    INPUT SELECT button 32, 52, 53, 57, 60, 61  
    MENU button 60  
    ONCE button 44, 60  
    PAUSE button 46, 53, 54, 57, 60  
    PLAY button 28, 49, 57, 60  
    QUICK-TIMER button 52, 60  
    REC buttons 32, 57, 60  
    SKIP button 28, 47, 60  
    SLOW button 47, 60  
    STILL ADJUST button 30, 47, 60  
    STOP 28, 57, 60  
    TAPE SPEED (SP/EP) 32, 53, 60  
    Tape Transport buttons 28, 46, 47, 60  
    TIMER CLEAR button 40, 60  
    TIMER REC (ON/OFF) button 9, 37, 44, 52, 57, 60  
    TRACKING AUTO/MANUAL button 30, 60  
    TRACKING NORMAL/  
SLOW button 47, 61

TV/VTR button 16, 37, 52, 55, 57  
VCR Plus+ button 44, 60  
VOL +/- button 60  
WEEKLY button 37, 44, 60

## C

Cable  
    hookup 8, 10, 12  
    VCR setup 9, 11, 13  
    VCR Plus+ channel setup 9, 11, 13  
CABLE BOX CONTROL 22-24, 70  
    Cable box code number chart 24  
    Cable Mouse 22  
    Checking the Cable Box Control  
Setting 24  
    Setting 23  
Cable TV channel assignment 21  
    Harmonic Related Carriers (HRC) 21  
    Incremental Related Carriers (IRC) 21  
Cassette  
    Cassette indicator 27, 59  
    Editing (See "Editing.")  
    Ejecting 27  
    Indexing (See "Indexing.")  
    Inserting 27  
    Playing back (See "Playback.")  
    Pausing a cassette 32, 33  
    Protecting your cassette against erasure 27  
    Recording/Playback times 27  
    Tape heads, cleaning 4  
    Tape speeds (EP, LP, SP) 27, 53  
Changing or cancelling timer settings (See "Timer Settings.")  
Channel  
    Channel Line-Up Chart 42  
    Channel indicator 59  
Cleaning  
    tape heads (automatic) 5  
    the VCR 4  
Clock  
CLOCK DISPLAY 59  
    CLOCK SET (See "Settings.")  
Connecting  
    EAC66 U/V band separator/mixer 56  
    External antenna connector 56  
Counter 29  
    counter reading 29  
    reset 29

## D

DIMMER 26  
Disabling unwanted channels 20  
Display 29  
Display window 57, 59  
    indicators 59  
DUAL MODE SHUTTLE ring (See "Variable Speed Playback.")

## E

Editing 55  
    Editing from another VCR 53  
    EDIT picture 53  
    Editing onto another VCR 54  
Ejecting a cassette (See "Cassette.")  
EP mode 27

## F

Fine Tuning 21  
    Fine-tuning indicator 21  
Front panel 57

## I

Indexing cassettes  
    described 48  
    Index Function 48  
    Index scan 49  
    Index search 50  
    Playing back from an index signal 49  
Input connectors, front panel 57  
INPUT SELECT 53  
Inserting a cassette (See "Cassette.")  
Installation 6-15, 56

## L

LANGUAGE (Canadian versions only) 26  
Linear time counter 29, 59  
LP mode 27, 46

## M

MAIN menu 19, 25, 31, 35, 39, 43  
Mixed hi-fi and normal track sound 31  
Monitor sound  
    Selecting monitor sound 30  
Multi-Channel TV sound (MTS) broadcasts 34

## N

NORMAL AUDIO 26  
NORM/CATV 9

## O

On-screen Display 30  
Owner's Record 2

## P

Picture adjustment (See "Adjusting.")  
PICTURE switch 53  
Playing a cassette 28  
    Frame-by-frame 47  
    Locked picture search 47  
    Pausing 46  
    Skip playback 47  
    Slow motion 47  
POWER ON/OFF indicator 55, 57  
POWER ON/OFF switch 55, 57, 60, 61  
Power interruption 61  
Preparing the Remote Commander 16  
Presetting (See "Setting.")



**R**

- Rear panel 58
- Recording
  - Automatic (timer) 35
  - Daily programs 37
  - Quick-timer 52
  - REC (Recording) indicator 57
  - Recording SAP (Second Audio Program) Broadcasts 34
  - Recording TV programs 32
  - Recording with the TV off 34
  - Stop 32
- Time (min/max) on cassettes 27
- Timer settings (See "Timer Settings.")
- VCR Plus+ 42-45
- Weekly programs 37
- Remote control (Commander) 16, 60
  - Inserting batteries 16
  - Operating 16
- Rewinding a cassette 28

**S**

- Safety 4
- SAP broadcasts 34
- Setting
  - Presetting desired channels 20
  - Presetting the active channels 19
  - Channels (automatically) 19
  - Clock 17
  - RF UNIT switch 55
  - Time (clock) and date 17
  - Timer (for recording) 35
- SET UP MENU 31
- Set VCR Plus+ channels (See "VCR Plus+.")
- Sound
  - Sound adjustment (See "Adjusting.")
  - Sound mode (See "Monitor Sound.")
- SP mode 27
- Specifications 63
- Stereo broadcast 34
- Stereo indicator 30
- Stereo program / SAP indicator 34, 59
- STILL ADJUST 60

**T**

- Tape (See "Cassette.")
- Timer recording
  - Buttons operable during timer recording 37
  - Overlapping timer recording 38
  - TIMER REC (recording) indicator 52, 57, 62
  - Timer recording function 35
  - Timer recording standby mode 37
- Timer settings
  - Cancelling 40
  - Changing 40
  - Checking 39
  - VCR Plus+ timer settings (See "VCR Plus+.")

- Timer, setting
  - TUNER PRESET 19
- Tracking adjustment 30
- Troubleshooting 61
- TV/VTR remote control selector 16, 60

**U**

- Using the VCR before timer recording starts 41

**V**

- Variable speed playback 46, 47
  - DUAL MODE SHUTTLE ring 28, 46, 47, 49, 57, 60
  - Picture search 46
- VCR Plus+ 42
  - Guide channel 43
  - PlusCode field 44
  - PlusCodes 42, 44





# *Video Cassette Recorder*

SLV-750HF/751HF

If you have any questions about this product, you may call:  
**Sony Customer Information Center**  
1-800-222-SONY (7669)

or write to:  
**Sony Customer Information Center**  
Sony Drive, Mail Drop # T1-11,  
Park Ridge, NJ 07656