

**SONY**

5-57-06-206

3-757-517-21 (1)

Video Camera Recorder **8**

# CCD-TR91

AC Power Adaptor  
**AC-V35**

## Operation Manual

Before operating the unit, please read this manual thoroughly and retain it for future reference.

### Owner's Record

The model and serial numbers are located on the bottom. Record the serial number in the space provided on the right hand. Refer to these numbers whenever you call upon your Sony dealer regarding this product.

Model No. CCD-TR91

Serial No. \_\_\_\_\_

Model No. AC-V35

Serial No. \_\_\_\_\_

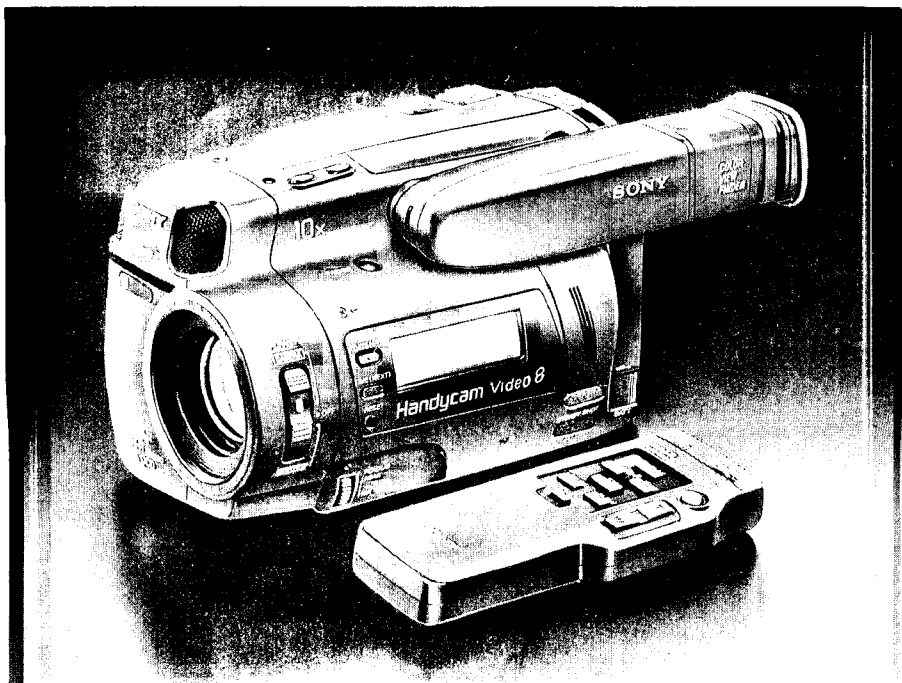

**Video 8 Handycam**

©1993 by Sony Corporation

## WARNING

To prevent fire or shock hazard,  
do not expose the unit to rain or  
moisture.

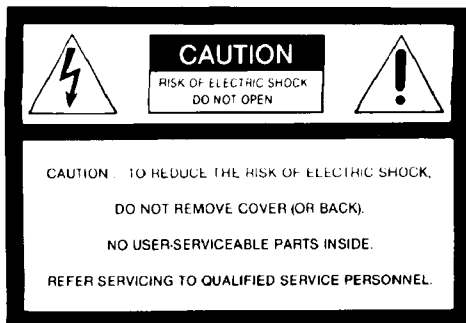

This symbol is intended to alert the user to the presence of uninsulated "dangerous voltage" within the product's enclosure that may be of sufficient magnitude to constitute a risk of electric shock to persons.



This symbol is intended to alert the user to the presence of important operating and maintenance (servicing) instructions in the literature accompanying the appliance.

## RECYCLING NICKEL-CADMIUM BATTERIES



Ni-Cd

**NICKEL-CADMIUM BATTERY.  
MUST BE DISPOSED OF PROPERLY.**

Nickel-Cadmium batteries are recyclable. You can help preserve our environment by returning your unwanted batteries to your nearest Sony Service Center or Factory Service Center for collection, recycling or proper disposal.

**Note:** In some areas the disposal of nickel-cadmium batteries in household or business trash may be prohibited.

For the Sony Service Center nearest you call  
1-800-222-SONY (United States only)  
For the Factory Service Center nearest you call  
416-499-SONY (Canada only)

**Caution:** Do not handle damaged or leaking  
nickel-cadmium batteries.

## For the Customers in the U.S.A.

### WARNING

This equipment has been tested and found to comply with the limits for a Class B digital device, pursuant to Part 15 of the FCC Rules. These limits are designed to provide reasonable protection against harmful interference in a residential installation. This equipment generates, uses, and can radiate radio frequency energy and, if not installed and used in accordance with the instructions, may cause harmful interference to radio communications. However, there is no guarantee that interference will not occur in a particular installation if this equipment does cause harmful interference to radio or television reception, which can be determined by turning the equipment off and on, the user is encouraged to try to correct the interference by one or more of the following measures:

- Reorient or relocate the receiving antenna.
- Increase the separation between the equipment and receiver.
- Connect the equipment into an outlet on a circuit different from that to which the receiver is connected.
- Consult the dealer or an experienced radio TV technician for help.

This device complies with Part 15 of the FCC Rules. Operation is subject to the following two conditions: (1) This device may not cause harmful interference, and (2) this device must accept any interference received, including interference that may cause undesired operation.

### CAUTION

You are cautioned that any changes or modifications not expressly approved in this manual could void your authority to operate this equipment.

## For the Customers in CANADA

### Notice for the customers in Canada

This apparatus complies with the Class B limits for radio noise emissions set out in Radio Interference Regulations.

### CAUTION

TO PREVENT ELECTRIC SHOCK, DO NOT USE THIS POLARIZED AC PLUG WITH AN EXTENSION CORD, RECEPTACLE OR OTHER OUTLET UNLESS THE BLADES CAN BE FULLY INSERTED TO PREVENT BLADE EXPOSURE.

## Welcome to Video 8

Congratulations on your purchase of this Sony Handycam® camcorder. With your Handycam you can capture life's precious moments with superior picture and sound quality. Your Handycam is loaded with advanced features, but at the same time it is very easy to use. You will soon be producing home video that you can enjoy for years to come.

## Table of Contents

### Before You Begin

- About This Manual 4
- Checking Supplied Accessories 5

### Getting Started

- Charging and Installing the Battery Pack 6
- Tips for Using the Battery Pack 8
- Inserting the Supplied Batteries 10
- Setting the Date and Time 12
- Inserting a Cassette 13
- Adjusting the Viewfinder Lens 14
- Hints for Better Shooting 15

### Basic Operations

- Camera Recording 16
  - Using the Zoom Feature 18
  - Getting a Steady Picture 19
  - Recording the Date or Time 19
  - Checking the Recorded Picture in the Viewfinder 20
- Connections for Playback 21
  - Connecting to a TV or a VCR with Audio/Video Input Jacks 21
  - Connecting to a TV without Audio/Video Input Jacks 21
- Playing Back a Tape 22

### Advanced Operations

- Using Alternative Power Sources 24
  - Using House Current 24
- Selecting Automatic or Manual Adjustment Mode 25
- Focusing Manually 26
- Using the PROGRAM AE Function 28
- Fade-in and Fade-out 30
- Changing the Mode Settings 31
- Editing onto Another Tape 33

### Additional Information

- Playback Modes 35
- Maintenance Information and Precautions 35
- Using Your Camcorder Abroad 39
- Identifying the Parts 40
  - Operation Indicators 43
  - Remote Commander 44
- Specifications 46
- Trouble Check 47
- Indicators in the Viewfinder and the Display Window 50
- Index 51

## About This Manual

If you want to shoot as soon as possible, read the chapters "Getting Started" and "Basic Operations" first. As you read through this manual, buttons and settings on the camcorder are shown in capital letters.

e.g. Set the POWER switch to CAMERA.

### Note on TV Color Systems

TV color systems differ from country to country. To view your recordings on a TV, you need an NTSC system based TV. When you want to use a PAL-M system based TV, you will need an NTSC/PAL-M transcoder (as this is an NTSC system based camcorder). Please check the list on page 39 to see the TV color system of your country.

### Note on the Supplied RFU Adaptor

Since each country has its own electricity and TV color system, you may not be able to use the RFU adaptor when you use the camcorder abroad.

### Precaution on Copyright

Television programs, films, video tapes, and other materials may be copyrighted. Unauthorized recording of such materials may be contrary to the provision of the copyright laws.

# Checking Supplied Accessories

Check that the following accessories are supplied with your camcorder.

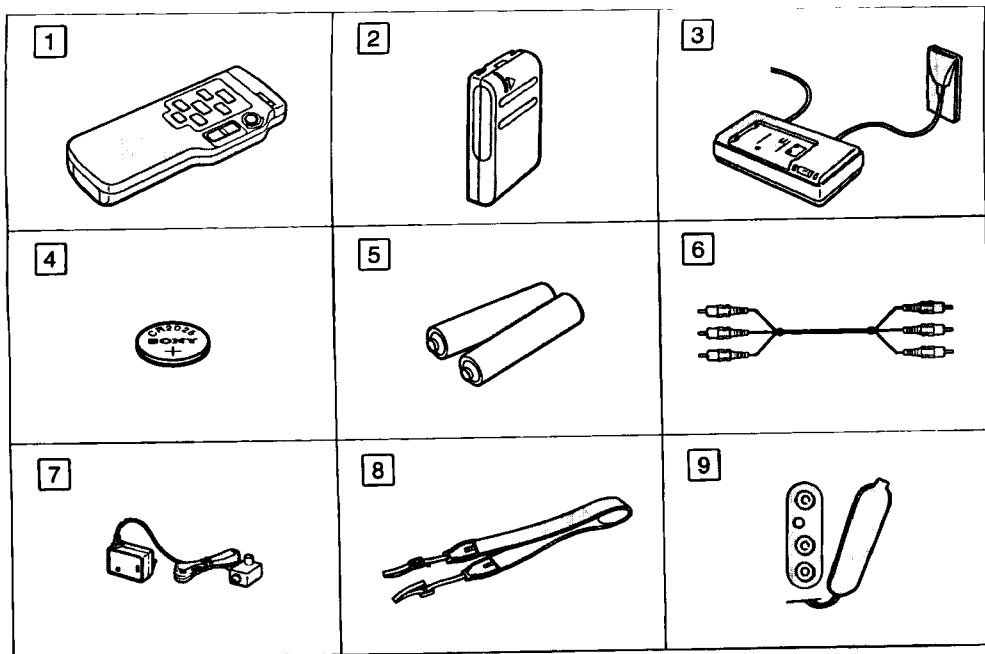

- 1 **Wireless Remote Commander** (1) (p. 44)
- 2 **NP-55H Battery pack** (1) (p. 6)
- 3 **AC-V35 AC power adaptor** (1) (p. 6)
- 4 **CR2025 Lithium Battery** (1) (p. 10)
- 5 **Size AA (R6) battery for Remote Commander** (2) (p. 11)
- 6 **A/V connecting cable** (1) (p. 21)
- 7 **RFU-90UC RFU adaptor** (1) (p. 21)
- 8 **Shoulder strap** (1) (p. 45)
- 9 **Jack cover** (1)  
(Attached to camcorder)

# Charging and Installing the Battery Pack

Before using your camcorder, you first need to charge and install the battery pack. To charge the battery pack, use the supplied AC-V35 AC power adaptor.

## Charging the Battery Pack

Charge the battery pack on a flat place without vibration.

(1) Connect the power cord to a wall outlet. (2) Align the right side of the battery pack with the line on the AC power adaptor, then slide the battery pack in the direction of the arrow. (3) Set the selector to CHARGE. The CHARGE lamp (orange) lights up. Charging begins.

When charging is completed, the CHARGE lamp goes out. Set the selector to the center position and unplug the unit from the wall outlet. Then remove the battery pack and install it on the camcorder. To stop charging, set the selector to the center position.

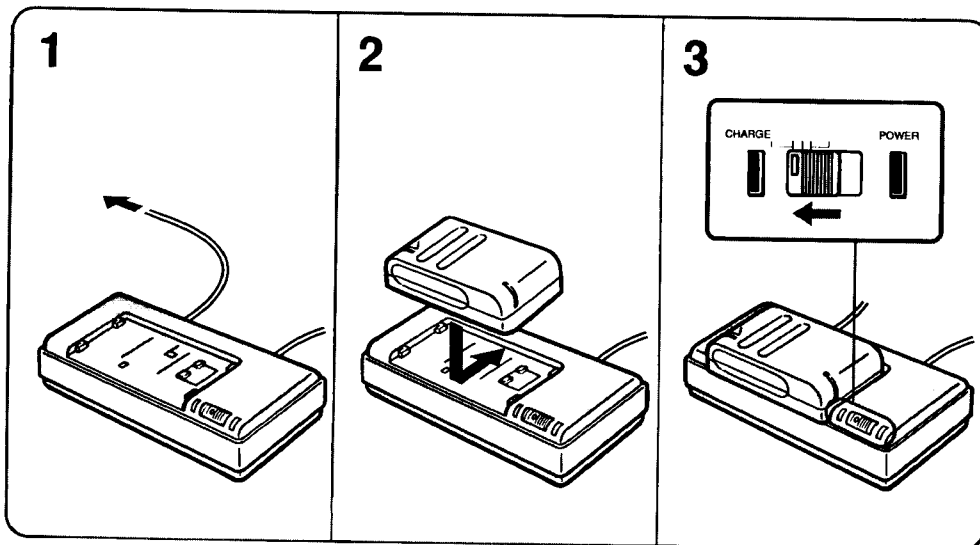

## Charging Time and Battery Life

Battery pack	NP-55H (supplied)	NP-80 NP-80D	NP-77H NP-77HD	NP-66H	NP-60D
Charging time*	70	155	140	100	75
Battery life**	60	140	135	100	65

\* Approximate minutes to charge an empty battery pack using the AC-V35 (Lower temperatures require a longer charging time.)

\*\* Approximate continuous recording time (in minutes) indoors

### Important!

#### Use the battery completely before re-charging!

Before you recharge the battery pack, make sure the battery has been used up (discharged) completely. Repeated charging while some capacity remains causes a lowering of battery capacity. However, the original battery capacity can be recovered if you use the battery completely and charge it fully again.

To use up the battery, remove the cassette and slide the POWER switch to CAMERA with the battery pack attached, and leave the camcorder until the  indicator and the red lamp flash in the viewfinder.

### Removing the Battery Pack

Slide the battery pack in the direction of the arrow (see drawing).

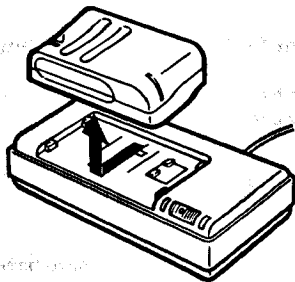

### Note on charging the battery pack

The POWER lamp will remain lit for a while even if the battery pack is removed and the power cord is unplugged after charging the battery pack. This is normal.

### Installing the Battery Pack

(1) Lift up the viewfinder. (2) Align the right side of the battery pack with the white line on the camcorder, and slide the battery pack to the right.

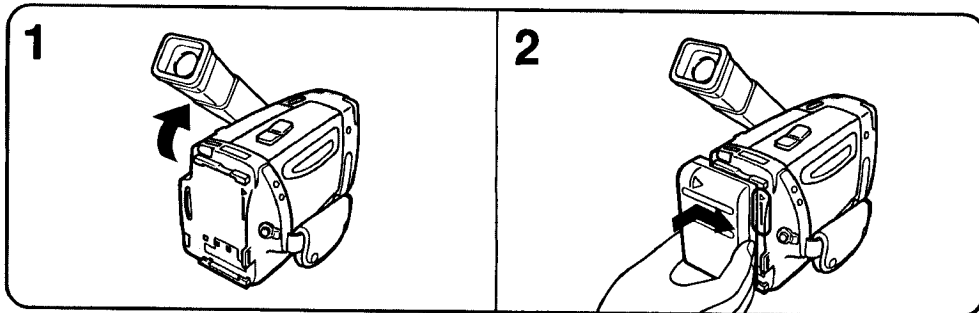

### Removing the Battery Pack

(1) Lift up the viewfinder. (2) While pressing BATT, slide the battery pack to the left.

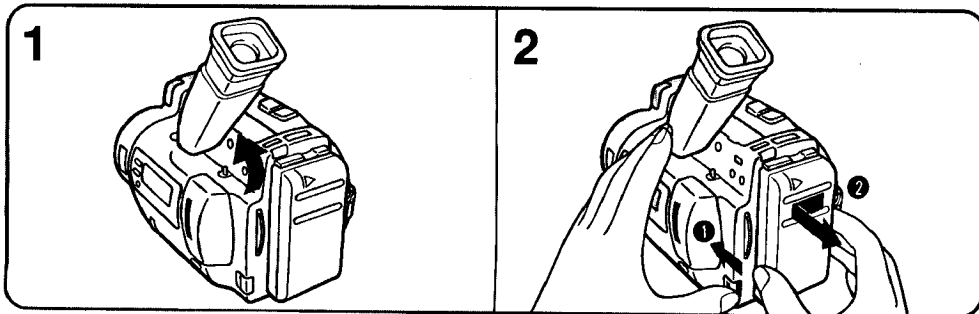

# Tips for Using the Battery Pack

This section shows you how you can get the most out of your battery pack.

## Preparing the Battery Pack

### Have Sufficient Battery Pack Power to Do 2 to 3 Times as much Recording as You have Planned.

"Battery life" indicated in this manual is measured by the continuous recording time of the camcorder, placed at room temperature using a fully-charged battery pack.

### Battery Life is Shorter in Cold Environment

Battery efficiency is decreased and the battery will be used up more quickly if you are recording in a cold environment.

### To Save Battery Power

Turn STANDBY on the camcorder down when not recording to save battery power. (p. 9) [a]  
A smooth transition between scenes can be made even if recording is stopped and started again. While you are positioning the subject, selecting an angle, or looking through the viewfinder lens, the lens moves automatically and the battery is used. The battery is also used when a tape is inserted or removed.

## When to Replace the Battery Pack

While you are using your camcorder, the remaining battery indicators in the viewfinder (1) and in the display window (2) decrease gradually as battery power is used up.

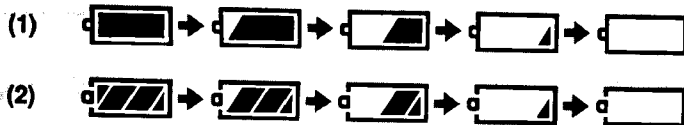

When the remaining battery indicator reaches the lowest point, the  indicator appears and starts flashing in the viewfinder. (p. 9) [b]

When the  indicator in the viewfinder changes from slow flashing to rapid flashing while you are recording, slide the POWER switch to OFF on the camcorder and replace the battery pack. Leave the tape in the camcorder to obtain a smooth transition between scenes after the battery pack is replaced.

### Note on the remaining battery indicator

The remaining battery indicator of the camcorder may indicate a different remaining capacity from that of the NP-77HD battery pack (not supplied). The indicator of NP-77HD is more accurate.

## Note on the Rechargeable Battery Pack

### The Battery Pack Heats Up

During charging or recording, the battery pack heats up. This is caused by energy that has been generated and a chemical change that has occurred inside the battery pack. This is not cause for concern.

### Battery Pack Care

- Remove the battery pack from the camcorder after using the battery pack, and keep it in a cool place. When the battery pack is attached to the camcorder, a small amount of current flows to the camcorder even if the POWER switch is set to OFF, which shortens battery life.
- The battery pack is always discharging even when it is not in use after charging. Therefore, you should charge the battery pack right before using the camcorder.

### How to Use the Switch on the Battery Pack

This switch is provided so that you can mark the charged battery pack. Set the switch to the "no mark" position when charging is completed. Set the switch to the "red mark" position when the battery is used up (or in whichever direction you want to remind yourself). (p. 9) [c]



## The Life of the Battery Pack

The battery pack can be fully charged and discharged about 500 times under normal temperatures. If the battery indicator flashes rapidly just after turning on the camcorder with a fully charged battery pack, the battery pack should be replaced with a new fully charged one.

## Charging Temperature

You should charge batteries at temperatures from 10°C to 30°C (from 50°F to 86°F). Lower temperatures require a longer charging time.

## Note on Charging

### A Brand-new Battery Pack

A brand-new battery pack is not charged. Before using the battery pack, charge it completely.

### Before Recharging a Used Battery Pack

- Make sure to use up the battery before recharging.
- If recording is completed before the  indicator appears in the viewfinder, you should remove the tape, slide the POWER switch to CAMERA, turn STANDBY up, and leave the camcorder until the battery indicator flashes rapidly.
- When you use the AC-S10 power adaptor, the DC-S10 car battery charger or the BC-S10 portable battery charger, you can use the discharging function.
- **Charging the usable battery pack causes a lowering of battery capacity. Battery capacity can be recovered if you fully discharge and charge the battery pack again.**

### After Long Storage

Recharge the battery pack after a long period of storage. If the battery pack is charged fully but not used for a long time (about 1 year), it becomes discharged. Charge it again, but in this case the battery life will be shorter than normal. After several charging and discharging cycles, the battery life will recover its original capacity.

## Note on the Terminals

**If the terminals (metal parts on the back) are not clean, the battery duration will be shortened.**

When the terminals are not clean or when the battery pack has not been used for a long time, repeat installing and removing the battery pack. This improves the contact condition. Also, wipe the + and - terminals with a soft cloth or paper.

### Be Sure to Observe the Following

- **To prevent an accident caused by a short circuit, do not allow metal objects such as a necklace to touch the battery terminals. Carry the battery pack attaching to the terminal cover. [d]**
- Keep the battery pack away from fire.
- Keep the battery pack dry.
- Do not open nor convert the battery pack.
- Do not expose the battery pack to any mechanical shock.

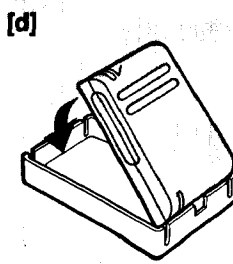
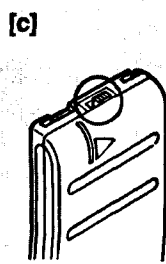
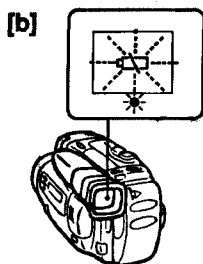
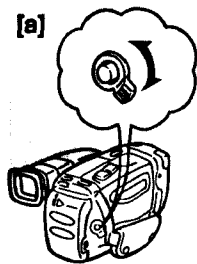

# Inserting the Supplied Batteries

Your camcorder is supplied with a lithium battery and two size AA (R6) batteries. The lithium battery is for the camcorder and the size AA (R6) batteries are for the Remote Commander.

## Inserting the Lithium Battery Into the Camcorder

The lithium battery has a positive (+) side and a negative (-) side as illustrated below. Be sure to install the lithium battery with the positive side facing out.

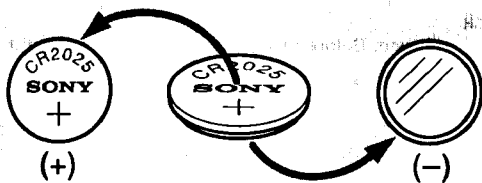

## Inserting the Lithium Battery

To activate the clock, you must insert a lithium battery.

(1) Open the lid of the lithium battery compartment on the bottom of the camcorder. (2) Install the lithium battery with the positive (+) side facing out. (3) Close the lid.

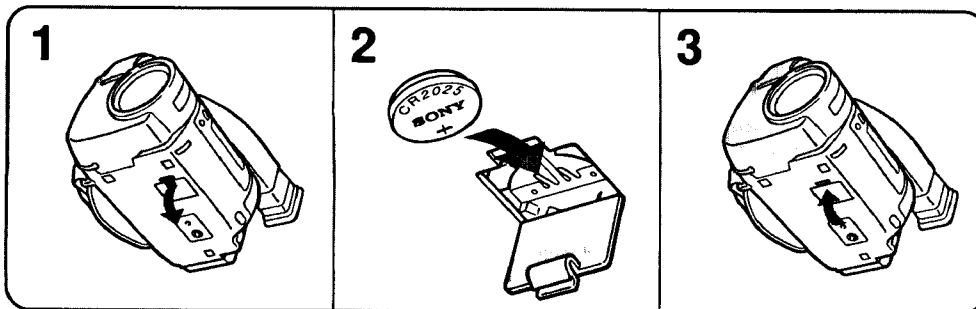

## To Remove the Lithium Battery

Push the battery upward once and pull it out from the holder.

When replacing the lithium battery, keep the battery pack or other power source attached. Otherwise, you will need to reset the date and time.

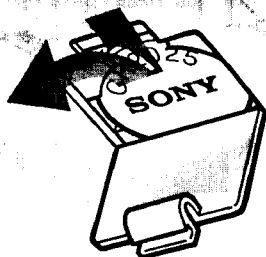

### Lithium Battery Life

The lithium battery for the camcorder lasts for about 1 year under normal operation. When the battery becomes weak or dead, the date or the time indicator and the  indicator flash in the viewfinder for about 5 seconds and the date or the time indicator keeps flashing in the display window when you set the POWER switch to CAMERA.

In this case, replace the battery with a Sony CR2025 or Duracell DL-2025 lithium battery. Use of any other battery may present a risk of fire or explosion.

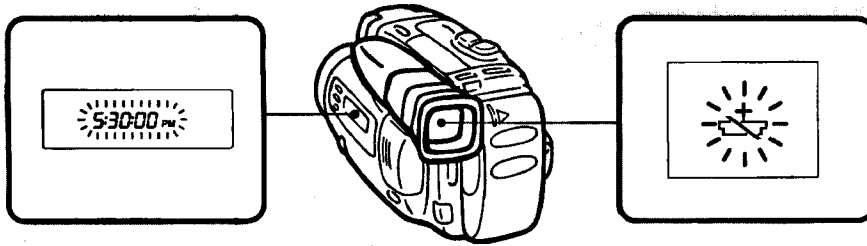

### Caution

Keep the lithium battery out of the reach of children.  
Should the battery be swallowed, consult a doctor immediately.

### Inserting the Size AA (R6) Battery into the Remote Commander

To use the Remote Commander, you must insert two size AA (R6) batteries. Use the supplied size AA (R6) batteries.

(1) Remove the battery cover from the Remote Commander. (2) Insert both of the size AA (R6) batteries with correct polarity. (3) Put the battery cover back onto the Remote Commander.

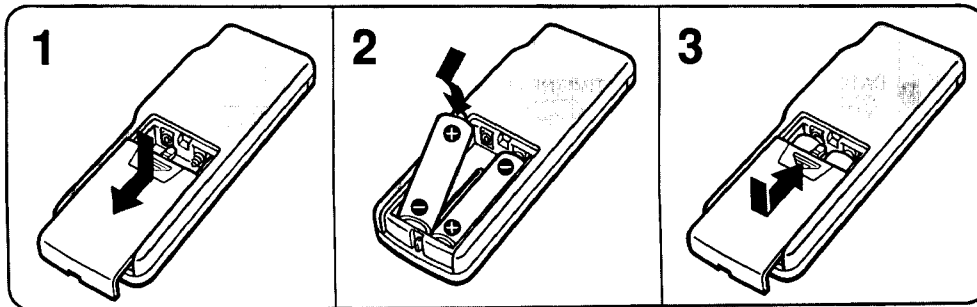

### Battery Life

The batteries for the Remote Commander last about 6 months under normal operation. When the batteries become weak or dead, the Remote Commander does not work.

### To avoid damage from possible battery leakage

Remove the batteries when you will not use the Remote Commander for a long time.

### WARNING

The battery may explode if mistreated. Do not recharge, disassemble, or dispose of in fire.

Inserting the Supplied Batteries

# Setting the Date and Time

You need to set the camcorder's date and time to record the correct ones onto your video. Before setting the clock, make sure a power source and lithium battery are installed.

(1) While pressing the small green button on the POWER switch, slide it to CAMERA. (2) Turn STANDBY up. (3) Move the viewfinder lens adjustment lever so that the "STBY" indicator in the viewfinder comes into sharp focus. (4) Press DATE (+) and TIME (NEXT) simultaneously for 3 seconds. (5) Adjust the digits of the year, month, day, hour and minutes by pressing DATE (+) and TIME (NEXT). To set the year to 1993, there is no need to press DATE (+) in 5-①. Note that when you keep DATE (+) pressed, the digits advance faster.

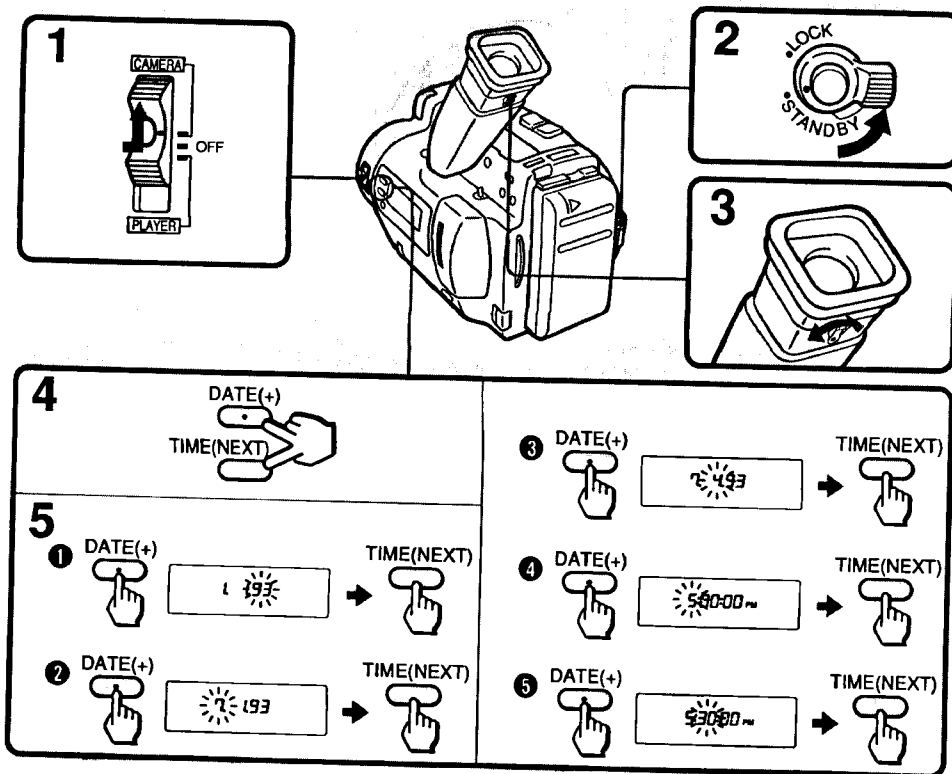

## To Correct the Date and Time Settings

Press TIME (NEXT) repeatedly until the minute digits stop flashing. Then repeat steps 4 and 5.

## To Check the Preset Date and Time

Press DATE (+) to display the date indicator in the viewfinder and the display window.  
Press TIME (NEXT) to display the time indicator. When you press the same button again, the indicator goes off.

#### Note on the setting of the year

When you set the year, each time you press DATE (+) the digits change as follows.

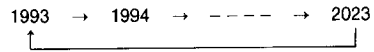

#### Note on the time indicator

The internal clock of this camcorder operates on a 12-hour cycle.

12:00 AM stands for midnight.

12:00 PM stands for noon.

## Inserting a Cassette

Make sure that the power source is installed.

(1) While pressing the small blue button on the EJECT knob, slide it in the direction of the arrow. The cassette holder automatically lifts up and opens. (2) Insert a tape with the window facing out. (3) Close the cassette holder by pressing the "PUSH" mark on the cassette holder.

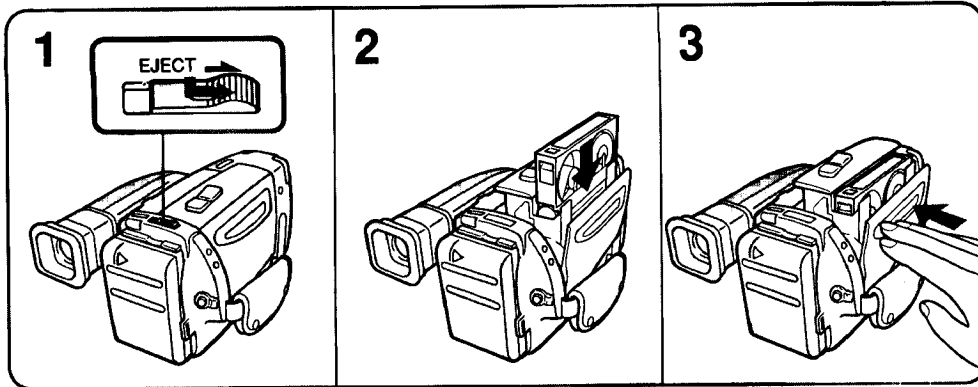

#### To Eject the Cassette

While pressing the small blue button on the EJECT knob, slide it in the direction of the arrow.

Setting the Date and Time / Inserting a Cassette

# Adjusting the Viewfinder Lens

Before you use the camcorder for the first time or after someone else has used it, focus the viewfinder lens. Make sure that the power source is attached to the camcorder.

(1) While pressing the small green button on the POWER switch, slide it to CAMERA. The lens cover opens. (2) Turn STANDBY up. (3) Move the viewfinder lens adjustment lever so that the indicators in the viewfinder come into sharp focus.

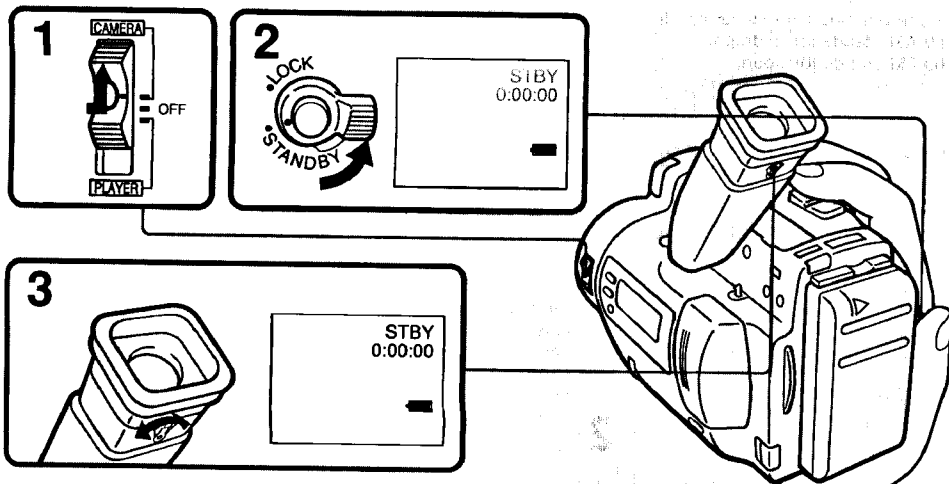

## To adjust the picture quality

If you want to change hue, color and brightness of the picture displayed on the viewfinder screen, turn the screws on the viewfinder slowly using a screwdriver (not supplied). You do not need to adjust them in everyday operation.

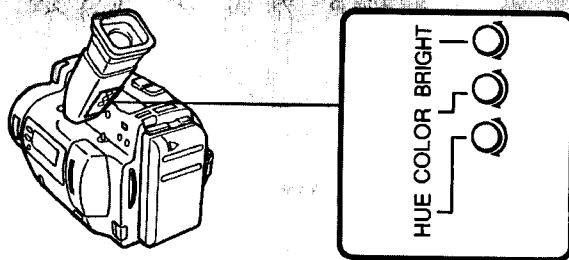

	Turn clockwise	Turn counterclockwise
BRIGHT	More brightness	Less brightness
COLOR	More color intensity	Less color intensity
HUE	Greenish skin tones	Reddish skin tones

## Hints for Better Shooting

For hand-held shots, you'll get better results by holding the camcorder according to the following suggestions:

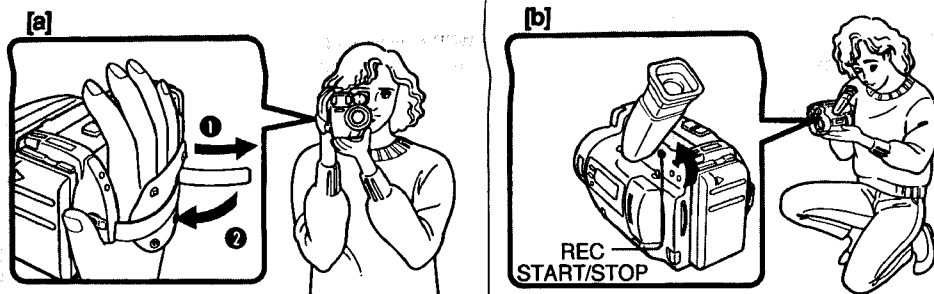

- Hold the camcorder firmly and secure it with the grip strap so that you can easily manipulate the controls with your thumb. **[a]**
- Place your right elbow against your side.
- Place your left hand under the camcorder to support it.
- Place your eye firmly against the viewfinder eyecup.
- Use the viewfinder frame as a guide to determine the horizontal plane.
- You can also record in a low position to get an interesting recording angle. Lift the viewfinder up for recording from a low position. (You can lift it up to 90 degrees.) Press REC START/STOP with your left thumb. **[b]**

### Place the camcorder on a flat surface or use a tripod

Try placing the camcorder on a table top or any other flat surface of suitable height. If you have a tripod for a still camera, you can also use it with the camcorder (p. 42). When attaching a non-Sony tripod, make sure that the length of the tripod screw is less than 6.5 mm (9/32 in.) Otherwise, the screw may damage the inner parts of the camcorder.

# Camera Recording

Make sure that the power source is installed and a cassette is inserted. If you set the date (p. 12), the date is automatically recorded for 10 seconds after you start recording (AUTO DATE feature). This feature works only once a day.

Before you record one-time events, you may want to make a trial recording to make sure that the camcorder is working perfectly.

(1) While pressing the small green button on the POWER switch, slide it to CAMERA. The lens cover opens. (2) Close the AUTO LOCK cover. Now all the camera functions activate automatically (i.e. focus, shutter speed). (3) Turn STANDBY up. (4) Press START/STOP. The camcorder starts recording. The "REC" indicator appears and the red lamp lights up in the viewfinder.

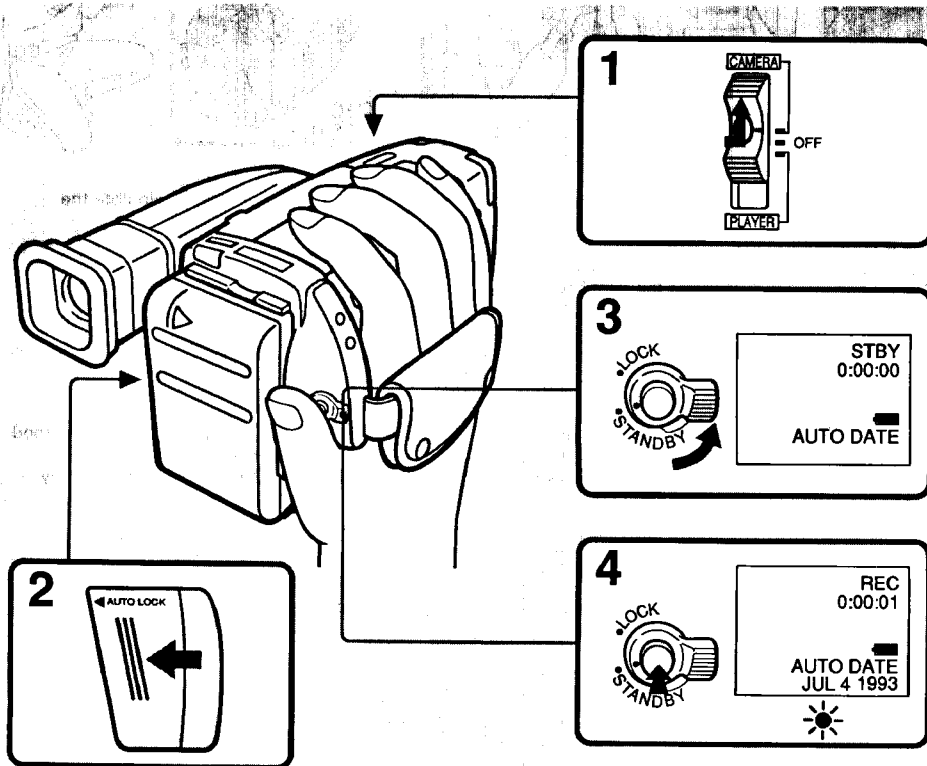

### To Stop Recording Momentarily

Press START/STOP again. The "STBY" indicator appears in the viewfinder (Standby mode).

### To Finish Recording

Turn STANDBY down and slide the POWER switch to OFF. The lens cover closes. Then, eject the tape (p. 13).

### Notes on Standby mode

If you leave the camcorder in Standby mode for 5 minutes, the camcorder goes off automatically. This prevents wearing down the battery and wearing out the tape. To resume Standby mode, turn STANDBY down once and turn it up again. To start recording, press START/STOP.



#### Note on the tape counter

The tape counter indicates the recording or playback time. Use it as a guide. There will be a time lag of several seconds from the actual time. To set the counter to zero, press RESET.

#### Note on the AUTO DATE feature

You can change the AUTO DATE settings by selecting ON or OFF in the menu system.

- The AUTO DATE feature works once a day. However, the date may automatically appear more than once a day when:
  - you reset the date and time.
  - you eject and insert the tape again.
  - you stop recording within 10 seconds.
  - you set AUTO DATE to OFF once and set to ON again in the menu system.
- Once the AUTO DATE feature turns off the date display 10 seconds after the start of recording, the date and time are displayed as follows:
  - If the date display setting has been made, the date is displayed.
  - If the time display setting has been made, the time is displayed.
  - If neither display setting has been made, nothing is displayed.

#### Note on BEEP Feature

A beep sounds when you turn the power on or when you start recording and two beeps sound when you stop recording, confirming the operation. Several beeps also sound as a warning of any unusual condition of the camcorder. Note that the beep sound is not recorded on the tape.

If you do not want to hear the beep sound, set BEEP to OFF in the menu system (p. 32).

#### When moving from indoors to outdoors (or vice versa)

Turn STANDBY up and point the camcorder at a white object for about 15 seconds so that the white balance is properly adjusted.

#### When there is a strong wind

Set WIND to ON in the menu system (p. 32). The noise from the wind will be reduced. The  indicator appears in the viewfinder.



After recording, set WIND to OFF. If you leave it ON, the sound may be recorded unnaturally.

#### Note on recording

When you record from the beginning of a tape, run the tape for about 15 seconds before starting the actual recording. This will ensure that you won't miss any start-up scenes when you play back the tape.

You can record tapes in SP (standard play) mode only.

## Preventing Accidental Erasure

To prevent accidental erasure, slide the tab on the cassette to expose the red mark. If you try to record with the red mark exposed, the  and  indicators flash in the viewfinder, and you cannot record.

To re-record on this tape, slide the tab back out covering the red mark.

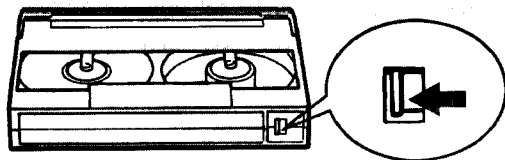

### Using the Zoom Feature

Zooming is a recording technique that lets you change the size of the subject in the scene. You can also use the zoom to focus manually or to decide on a shooting angle before you start recording.

For more professional-looking recordings, use the zoom function sparingly.

"T" side: for telephoto (subject appears closer)

"W" side: for wide-angle (subject appears farther away)

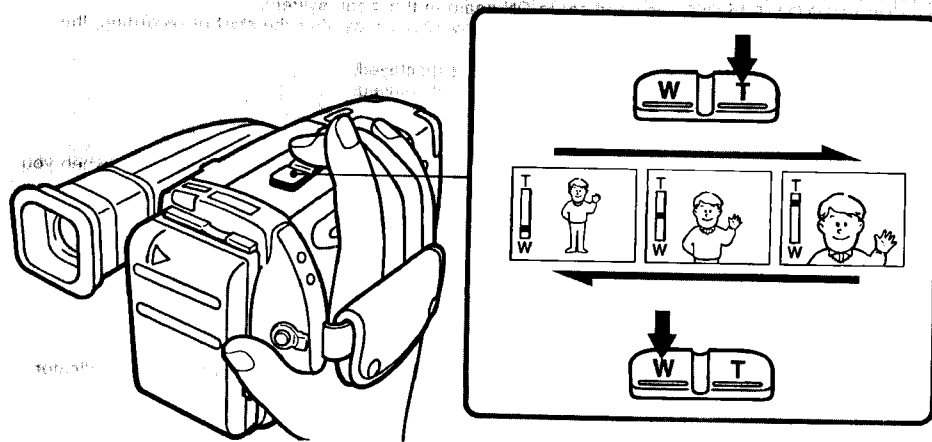

### Zooming Speed (Dual speed zooming)

Press the power zoom button firmly for a high-speed zoom, press it softly for a relatively slow zoom.



### When you shoot a subject using a telephoto zoom

If you cannot get a sharp focus while in extreme telephoto zoom, press the "W" side of the power zoom button until the focus is sharp. You can shoot a subject that is at least 1 m (about 39 3/8 inches) away from the lens surface in the telephoto position.

### Manual focusing in macro

You can also shoot with manual focus while doing close-ups (p. 27).

## Getting a Steady Picture

You can use the Steady Shot function to compensate for camera-shake. Set STEADY SHOT to ON. The  indicator appears in the viewfinder and the  indicator appears in the display window.

Use Steady Shot:

- When you zoom in
- When you shoot scenery from a car window
- When you shoot scenes while moving

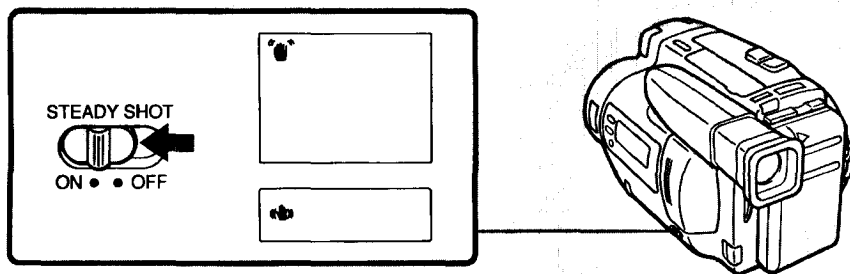

## To Release Steady Shot Function

Set STEADY SHOT to OFF.

### Notes on using Steady Shot

- To conserve the battery, set STEADY SHOT to OFF when you don't need it. When it is set to ON, battery power is used up more quickly.
- Steady Shot will not correct excessive camera movement.
- When you shoot stationary objects with a tripod, set STEADY SHOT to OFF.

## Recording the Date or Time

While you are recording, press DATE (+) or TIME (NEXT). The date or time displayed in the viewfinder is recorded with the picture. You cannot record the date and time at the same time. Except for the date or time indicator, no indicator in the viewfinder is recorded.

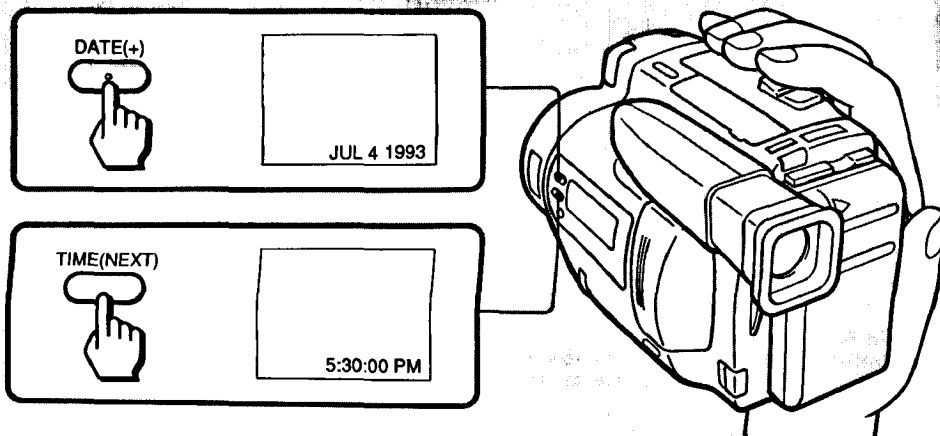

## To Stop Recording with the Date and Time

Press DATE (+) or TIME (NEXT) again. The date or time indicator disappears. The recording continues.

## Checking the Recorded Picture in the Viewfinder

Using EDITSEARCH, you can review the last recorded scene or check the recorded picture in the viewfinder.

(1) While pressing the small green button on the POWER switch, slide it to CAMERA. (2) Turn STANDBY up. (3) Press the - (⊖) side of EDITSEARCH momentarily; the last few seconds of the recorded portion plays back (**Rec Review**).

Keep pressing EDITSEARCH to play back the last recorded portion (**Edit Search**).

+ side: to view the forward playback picture

- side: to view the reverse playback picture

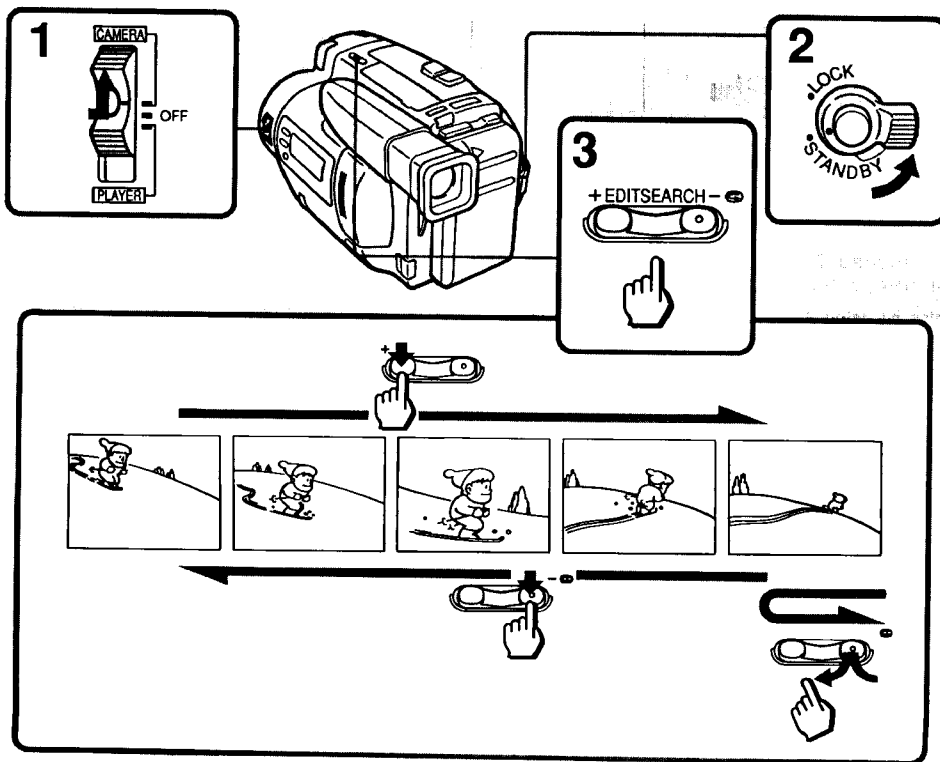

## Monitoring the Sound while Viewing the Playback Picture In the Viewfinder

Connect headphones (not supplied) to the PHONES jack. Play back the tape in PLAYER mode (p. 22).

### To Stop Playback

Release EDITSEARCH.

### To Begin Re-recording

Press START/STOP. Re-recording begins from the point you released EDITSEARCH. Provided you do not eject the tape, the transition between the last scene you recorded and the next scene you record will be smooth.

### Note on using EDITSEARCH

You cannot hear the recorded sound during Edit Search.

## Connections for Playback

You can use this camcorder as a VCR by connecting it directly to your TV for playback. There are two ways to connect the camcorder to your TV.

### Connecting to a TV or a VCR with Audio/Video Input Jacks

Connect the camcorder to the TV by using the supplied connecting cable. Set the TV/VCR selector on the TV to VCR. When connecting the camcorder to VCR, set the input selector on the VCR to LINE.

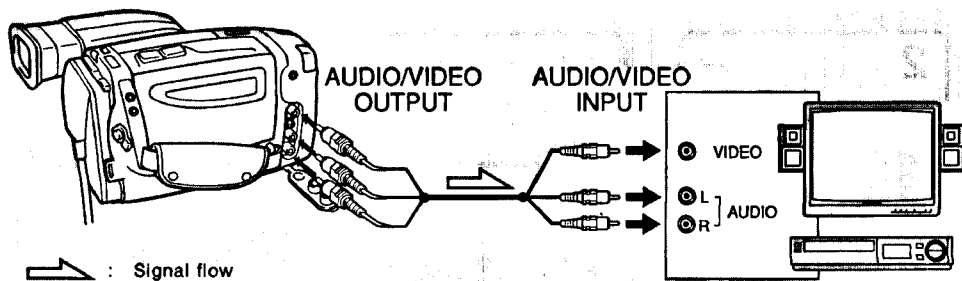

If your TV or VCR is a monaural type, connect only the white plug for audio on both the camcorder and the TV or the VCR. With this connection, the sound is in monaural.

### Connecting to a TV without Audio/Video Input Jacks

Connect the camcorder to the TV by using the supplied RFU adaptor. Set the channel selector on the RFU adaptor to 3CH or 4CH whichever is not used in your area. Turn on the TV and select the 0 position. Tune the TV so that you can get picture and sound from the camcorder.

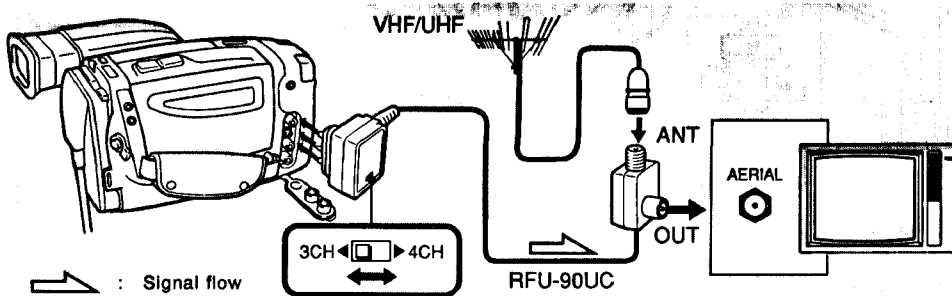

# Playing Back a Tape

## Playing Back a Tape

You can monitor the playback picture in the viewfinder. You can also monitor the picture on a TV screen, after connecting the camcorder to a TV or VCR (p. 21). You can use the supplied Remote Commander to control playback, if you want. Before using the Remote Commander, slide the HOLD switch in the opposite direction of the arrow.

(1) While pressing the small green button on the POWER switch, slide it to PLAYER. (2) Insert the recorded tape with the window facing out. (3) Press . Playback starts.

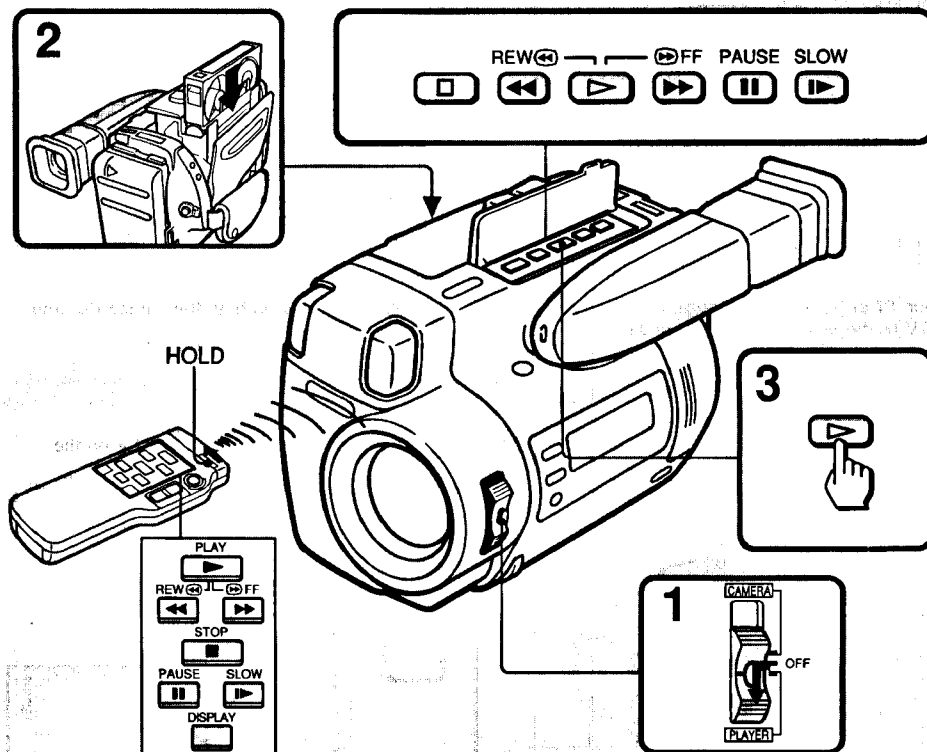

To stop playback, press .

To rewind the tape, press .

To advance the tape rapidly, press .

To play back at 1/5 speed, press .

### When you use the Remote Commander

Make sure COMMANDER is set to ON in the menu system (p. 32), and the HOLD switch on the Remote Commander is not working.

When you do not use the Remote Commander, slide the HOLD switch in the direction of the arrow to prevent any misoperation.

## Various Playback Modes

### To view a still picture (Playback pause)

Press **||** during playback. To resume playback, press **||** or **>**.

### To locate a scene (Picture search)

Keep pressing **<<** or **>>** during playback. To resume normal playback, release the button.

### To monitor the high-speed picture during advancing the tape or rewind (Skip scan)

Keep pressing **<<** while rewinding or **>>** while advancing the tape. To resume normal playback, press **>**.

### To view the picture in a sequence of stop-motion images

Press EDITSEARCH in Playback pause mode. If you keep pressing EDITSEARCH, you can view the picture play back in the forward (+) or reverse (-) direction.

### Note on playback

- Streaks appear and the sound is muted in the various playback modes.
- When Playback pause mode lasts for 5 minutes, the camcorder automatically enters stop mode.

### To display the viewfinder screen indicators on the TV

Press DISPLAY on the Remote Commander. To erase the indicators, press it again.

### To select the playback sound

Change the "HiFi SOUND" mode setting in the menu system (p. 32).

## Using Alternative Power Sources

You can choose any of the following power sources for your camcorder: battery pack (p. 6), house current, and 12/24 V car battery. Choose the appropriate power source depending on where you want to use your camcorder.

Place	Power source	Accessory to be used
Indoors	House current	AC-V35 AC power adaptor (supplied), AC-S10, AC-V55, AC-V35A
Outdoors	Battery pack	NP-55H Battery pack (supplied), NP-80D, NP-80, NP-77HD, NP-77H, NP-66H, NP-60D
In the car	12 V or 24 V car battery	DCP-77 DC pack

### Using House Current

To use the supplied AC-V35 AC power adaptor:

(1) Lift up the viewfinder. (2) Connect the AC power cord to a wall outlet. Connect the connecting plate to the battery mounting surface of the camcorder. (3) Set the selector to VTR (DC OUT).

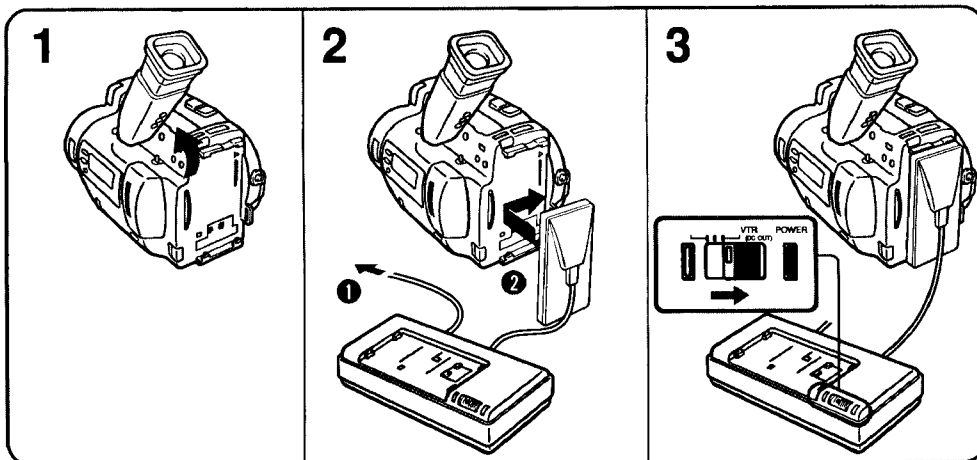

#### Notes on the AC power adaptor

- The camcorder cannot be operated while charging the battery pack.
- The camcorder cannot be operated unless the selector is changed to VTR (DC OUT) position.
- Keep the adaptor away from the video equipment if video operation is disturbed.
- The POWER lamp will remain lit for a while even if the unit is unplugged after use. This is normal.

#### To remove the connecting plate

The connecting plate is removed in the same way as the battery pack. (p. 7)

### Using a Car Battery

Use the DCP-77 DC pack (not supplied). Connect the cord of the DC pack to the cigarette lighter socket of the car (12 V or 24 V). Connect the DC pack to the battery mounting surface of the camcorder.

#### To remove the DC pack

The DC pack is removed in the same way as the battery pack. (p. 7)



## Options for Charging the Battery Pack

- AC-S10 AC power adaptor:  
You can charge a battery pack whether it is used up or not with this adaptor because it has a discharging function.
- BC-S10 portable battery charger (ideal for travel):  
You can charge a battery pack on 100-240 V AC current.

## Selecting Automatic or Manual Adjustment Mode

The camcorder's automatic functions offer you worry-free operation under most shooting conditions. But in some circumstances, manual adjustment is better for creative recording.

### Automatic Adjustment Mode

Close the AUTO LOCK cover. In automatic mode, the camcorder adjusts the focus automatically. It also sets the shutter speed to 1/60.

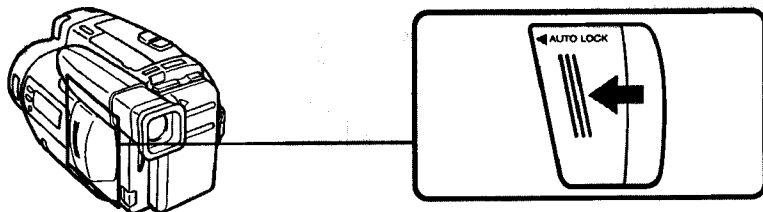

### Manual Adjustment Mode

Open the AUTO LOCK cover. In manual mode, you can adjust the focus manually, and select from four PROGRAM AE modes to fit the shooting situation. Even if in manual mode, the settings you didn't adjust manually remain the same as when in automatic adjustment mode.

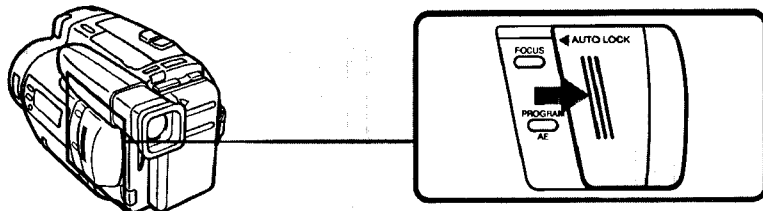

#### About the previous settings

Manual settings are saved in the following case:

- When you resume automatic mode after you make manual adjustments and then select manual mode again.
  - When you set the POWER switch to OFF.
- However, manual settings are cancelled once 5 minutes pass if you have removed the battery.

# Focusing Manually

## When to Use Manual Focus

In the following cases you should obtain better results by adjusting the focus manually.

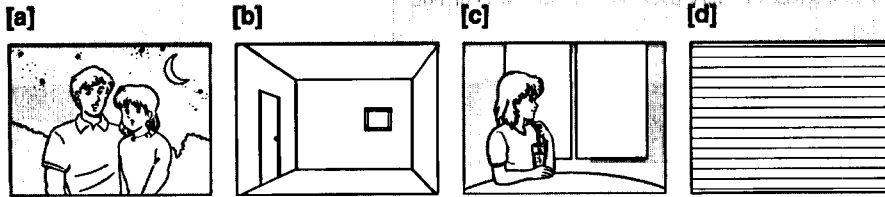

- Insufficient light [a]
- Subjects with little contrast — walls, sky, etc. [b]
- Too much brightness behind the subject [c]
- Horizontal stripes [d]
- Subject through frosted glass
- Subjects beyond nets, etc.
- Bright subject or subject reflecting light
- Shooting a stationary subject when using a tripod

## Focusing Manually

When focusing manually, first focus in telephoto before recording, and then reset the shot length.

(1) Open the AUTO LOCK cover. (2) Press FOCUS. The  indicator appears in the viewfinder and FOCUS MANUAL indicator appears in the display window. (3) Keep pressing the "T" (telephoto) side of the power zoom button until the zooming stops. (4) Turn the focus dial to achieve a sharp focus. (5) Set the desired shot length.

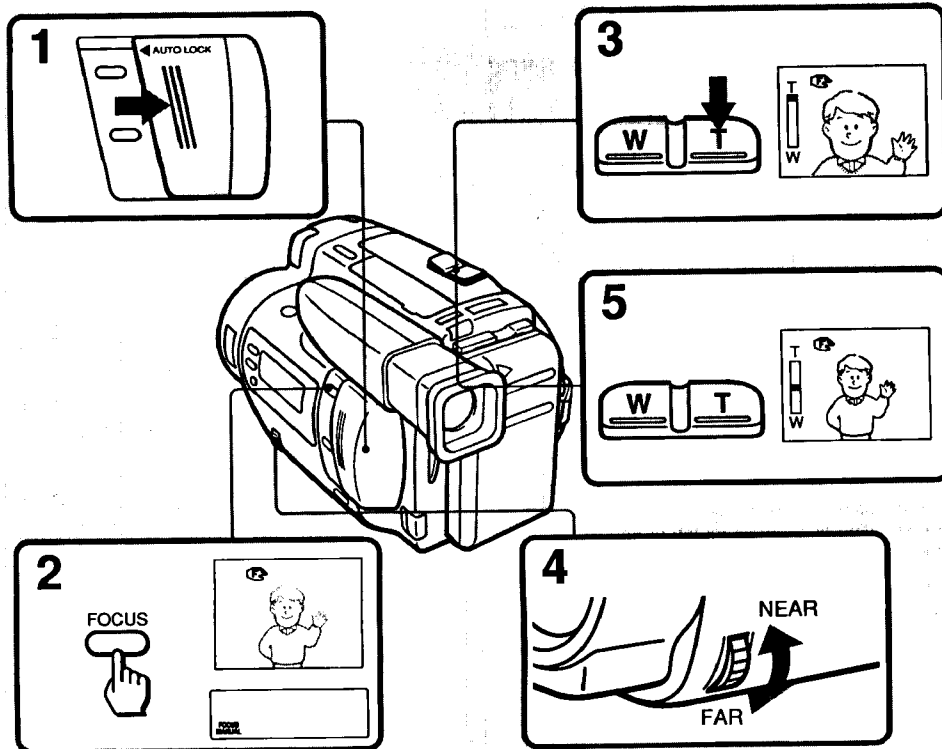

### To Reactivate Autofocusing

Press FOCUS again, or close the AUTO LOCK cover. The  indicator in the viewfinder and FOCUS MANUAL indicator in the display window disappear.

### Shooting in relatively dark places

Shoot at wide-angle after focusing in the telephoto position.

### Note on the focus dial

The focus dial does not have a stop position.

# Using the PROGRAM AE Function

You can select from four PROGRAM AE (Auto Exposure) modes to suit your shooting situation. When you use PROGRAM AE, you can get a Portrait effect (the subject is in focus and the background is out of focus), capture high-speed action, or record night views.

## Selecting the Best Mode

Select one of four modes, referring to the following.



### **Portrait mode**

- A still subject such as a person or a flower
- Zooming in on a subject in the telephoto mode
- A subject behind an obstacle such as a net

### **Sports mode**

- Outdoor sports scene such as football, tennis, golf or skiing
- A landscape in a moving car

### **High-speed shutter mode**

- A golf swing or a tennis match in fine weather with the ball captured clearly
- Playing back certain scenes with high-speed movements in a clear, sharp picture

### **Twilight mode**

Recording night views, neon signs or fireworks

## Using the PROGRAM AE Function

(1) Open the AUTO LOCK cover. (2) Press PROGRAM AE. The indicator of the selected PROGRAM AE mode appears in the viewfinder and the display window.

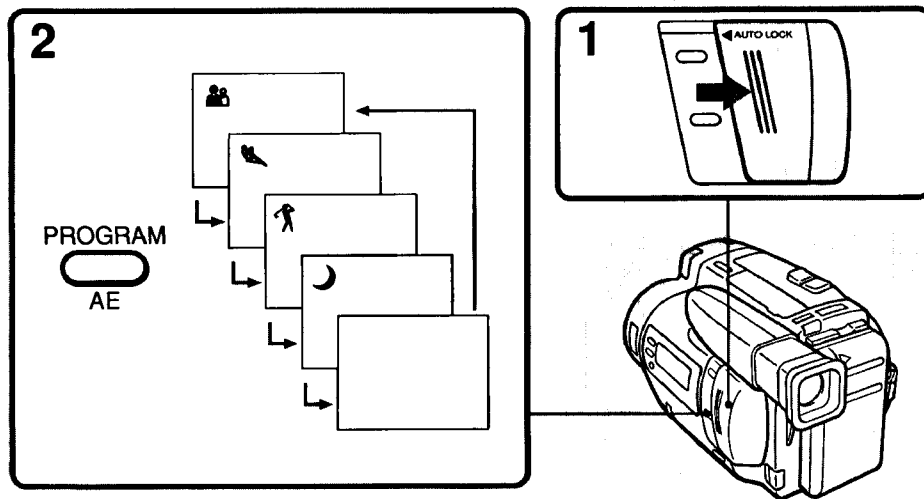

### Note on shutter speed

The shutter speed in each PROGRAM AE mode is as follows:

Portrait mode — between 1/60 to 1/2000

Sports mode — between 1/60 to 1/500

High-speed shutter mode — 1/4000

Twilight mode — 1/60

Using the PROGRAM AE Function

## Fade-In and Fade-out

You can fade a picture in or out with sound to give your recording a professional appearance. When fading in, you can make the picture gradually appear from black or mosaic while increasing the sound. When fading out, you can make the picture gradually fade to black or mosaic while decreasing the sound.

### When Fading in [a]

(1) While the camcorder is in Standby mode, press FADER. (2) Press START/STOP. The fade indicator stops flashing and the recording starts fading in.

### When Fading out [b]

(1) During recording, press FADER. (2) Press START/STOP. The fade indicator stops flashing and the picture fades out. Then, recording stops.

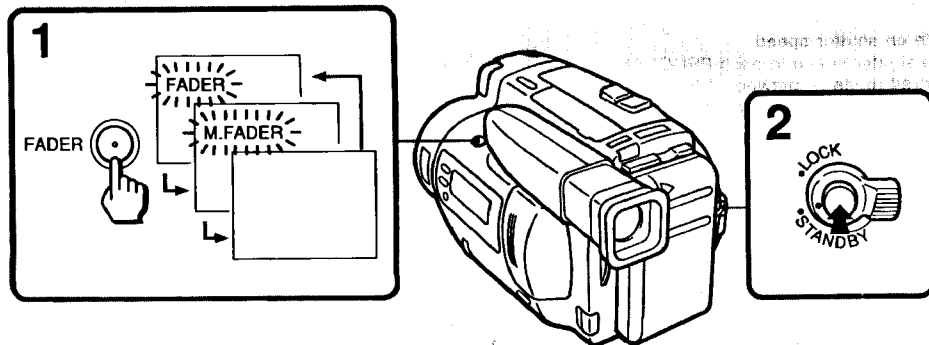
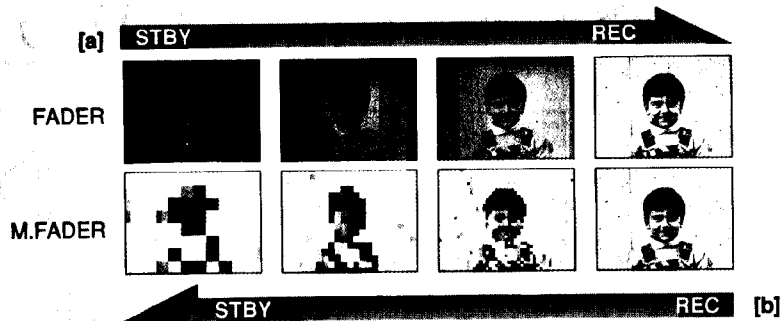

### To Cancel the Fade-In/Fade-out Function

Before pressing START/STOP, press FADER until the fade indicator disappears.

# Changing the Mode Settings

You can change the mode settings in the menu system to further enjoy the features and functions.  
 (1) Lift up the viewfinder. (2) Press MENU to display the menu in the viewfinder. ([a] Menu for CAMERA mode, [b] Menu for PLAYER mode) (3) Press ITEM to move the cursor ► and select the desired item.  
 (4) Press SET to move the cursor ● or ○ and set the desired mode. If you want to change the other modes, repeat steps 3 and 4. (5) Press MENU to erase the menu display.

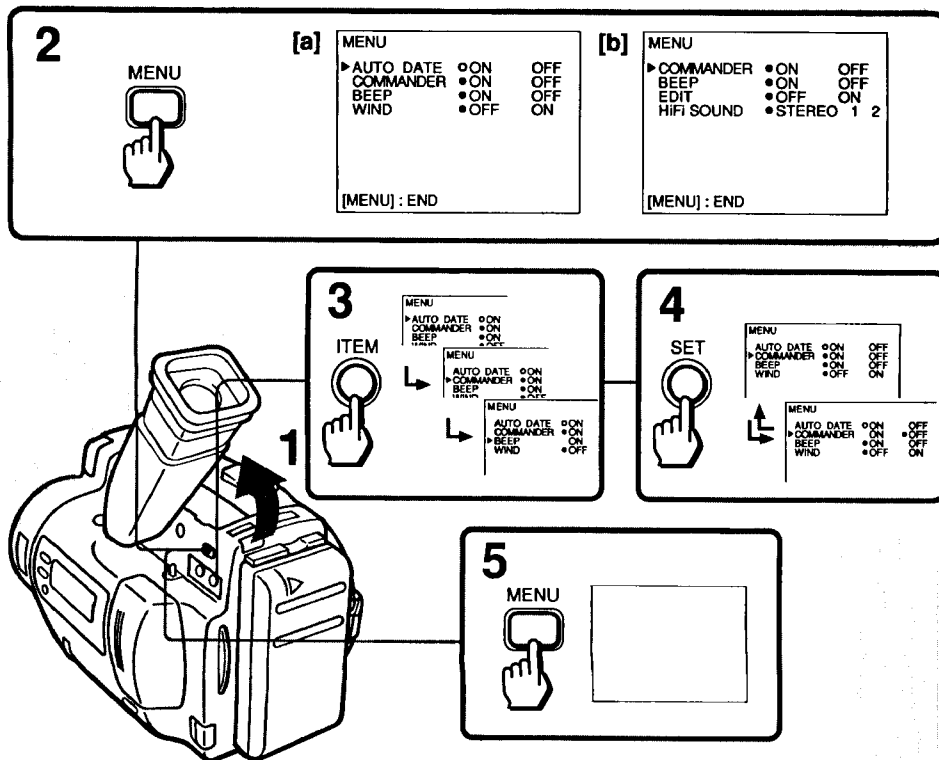

Fade-in and Fade-out / Changing the Mode Settings

### Note on the cursor ○

The settings of items marked with the cursor ○ are retained even when the battery is removed, as long as the lithium battery is in place.

## Changing the Mode Settings

### Selecting the Mode Setting of Each Item

#### **AUTO DATE <ON/OFF>**

In PLAYER mode, this option is not displayed.

- Select ON to record the date for 10 seconds after recording has started.
- Select OFF for not recording the date.

#### **COMMANDER <ON/OFF>**

- Select ON when using the supplied Remote Commander for the camcorder.
- Select OFF when not using the Remote Commander.

#### **BEEP <ON/OFF>**

- Select ON to hear the beep sound.
- Select OFF otherwise.

#### **WIND <ON/OFF>**

In PLAYER mode, this option is not displayed.

- Select ON when recording in a strong wind.
- Normally select OFF.

#### **EDIT <ON/OFF>**

In CAMERA mode, this option is not displayed.

- Select ON to minimize picture deterioration when editing.
- Select OFF otherwise.

#### **HIFI SOUND <STEREO/1/2>**

In CAMERA mode, this option is not displayed.

- Normally select STEREO.
- Select 1 or 2 to play back a dual sound track tape.



# Editing onto Another Tape

You can create your own video program by editing with any other **8** 8 mm, **Hi8** Hi8, **VHS** VHS, **S-VHS** S-VHS, **VHS-C** VHS-C, **S-VHS-C** S-VHS-C, **B** Betamax or **ED Beta** ED Betamax VCR that has audio/video inputs.

## Before Editing

Connect the camcorder to the VCR using the A/V connecting cable (supplied). (p. 21)

Set the input selector on the VCR to LINE, if available.

(1) Set the POWER switch to PLAYER. (2) Set EDIT to ON in the menu system (p. 32).

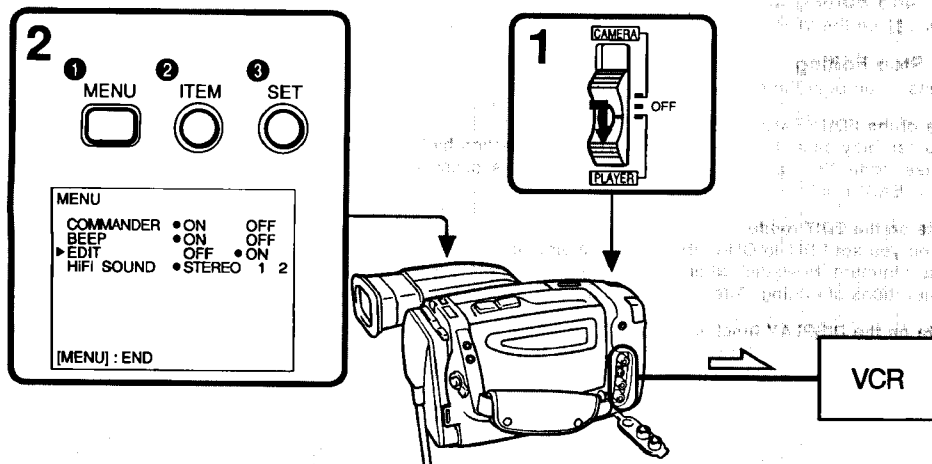

➤ : Signal flow

If your VCR is a monaural type, connect only the white plug for audio on both the camcorder and VCR.

Changing the Mode Settings / Editing onto Another Tape

## Editing onto Another Tape

### Starting Editing

(1) Insert a blank tape (or a tape you want to record over) into the VCR. And insert your recorded tape into the camcorder. (2) Play back the recorded tape on the camcorder until you locate the point where you want to start editing, then set the camcorder in the Playback pause mode. (3) On the VCR, locate the recording start point and set the VCR in the recording pause mode. (4) Press **||** on the camcorder and VCR simultaneously to start editing.

### To Edit More Scenes

Repeat steps 2 to 4.

### To Stop Editing Momentarily

Press **||** on the VCR.

### To Stop Editing

Press **□** on both the camcorder and the VCR.

### Use of the EDITSEARCH button

You can play back the tape in normal/reverse direction by keep pressing EDITSEARCH during Playback pause mode. You can also play back still pictures successively at specific intervals by pressing EDITSEARCH intermittently.

### Note on the EDIT mode

When you set EDIT to ON in the menu system, you can keep picture deterioration resulting from editing to a minimum. However, when you edit or copy to another VCR, avoid using the edited tape for multiple generations of editing. After editing, be sure to set EDIT to OFF.

### Note on the DISPLAY function

If you have displayed the viewfinder screen indicators on the TV, erase the indicators by pressing DISPLAY on the Remote Commander so that they will not be superimposed on the edited tape.

## Playback Modes

The playback mode (SP or LP) is selected automatically according to the format in which the tape has been recorded. The quality of the recorded picture in LP mode, however, will not be as good as that in SP mode.

### Note on AFM Hi-Fi stereo

When you play back a tape, the sound is in monaural if:

- You record the tape using this camcorder, then play it back on an AFM Hi-Fi monaural video recorder/player.
- You record the tape on an AFM Hi-Fi monaural video recorder, then play it back on this camcorder.

### Dual sound

You can play back a dual sound track tape. Set HiFi SOUND to "1" or "2" in the menu system. (p. 32)

### LP (long play) mode

When you play back a tape recorded in LP mode, the LP indicator lights up in the viewfinder. This camcorder cannot record a tape in LP mode.

### Foreign 8 mm video



You cannot play back software recorded on a different TV color system. Because the TV color systems differ from country to country, you may not be able to play back foreign pre-recorded software. Refer to page 39 to check the TV color system of foreign countries.

## Maintenance Information and Precautions

### Moisture Condensation

If the camcorder is brought directly from a cold place to a warm place, moisture may condense inside the camcorder, on the surface of the tape, or on the lens. In this condition, the tape may stick to the head drum and be damaged or the unit may not operate correctly. To prevent possible damage under these circumstances, the camcorder is furnished with moisture sensors. However, take the following precautions.

#### Inside the Camcorder

When the  and  indicators flash in the viewfinder, moisture has condensed inside the camcorder. If this happens, no other functions except for tape ejection will work.

**Eject the tape, turn off the camcorder and leave it with the cassette holder open for at least one hour in a dry place.**

The camcorder can be used again if the  indicator does not appear when the power is turned on again.

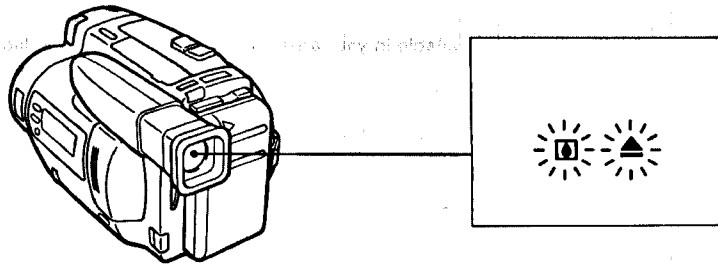

## Maintenance Information and Precautions

### On the Surface of the Tape

If there is moisture on the surface of the tape, when the cassette is inserted and a tape transport button is pressed, the ▲ indicator in the viewfinder flashes.

In this case, no other functions except for tape ejection will work. **Eject the tape, turn off the camcorder and leave it with the cassette holder open for at least one hour in a dry place.** The camcorder can be used again if the ▲ indicator does not appear when you insert the cassette and press one of the tape transport buttons.

### On the Lens

If moisture condenses on the lens, no indicator appears, but the picture becomes dim. Turn off the power and do not use the camcorder for about one hour.

### How to Prevent Moisture Condensation

When bringing the camcorder from a cold place to a warm place, put the camcorder in a plastic bag and allow it to adapt to room conditions over a period of time.

- (1) Be sure to tightly seal the plastic bag containing the camcorder.
- (2) Remove the bag when the air temperature inside it has reached the temperature surrounding it (after about 1 hour).

## Video Head Cleaning

To ensure clear pictures, clean the video heads periodically. When playback pictures are "noisy" or hardly visible, the video heads may be contaminated.



[a]

[b]

[a] Slight contamination

[b] Critical contamination

If this happens, clean the video heads with the Sony V8-25CLH cleaning cassette (not supplied). After checking the picture, if it is still "noisy", repeat the cleaning. (Do not repeat cleaning more than 5 times.)

### Caution

Do not use a commercially available wet-type cleaning cassette. It may damage the video heads.

### Note

If the V8-25CLH cleaning cassette is not available in your area, consult your Sony service facility.

## Removing Dust from Inside the Viewfinder

(1) While pressing down the hook, slide the viewfinder barrel in the direction of the arrow and remove it from the viewfinder. (2) Clean the surface with a commercially available blower.

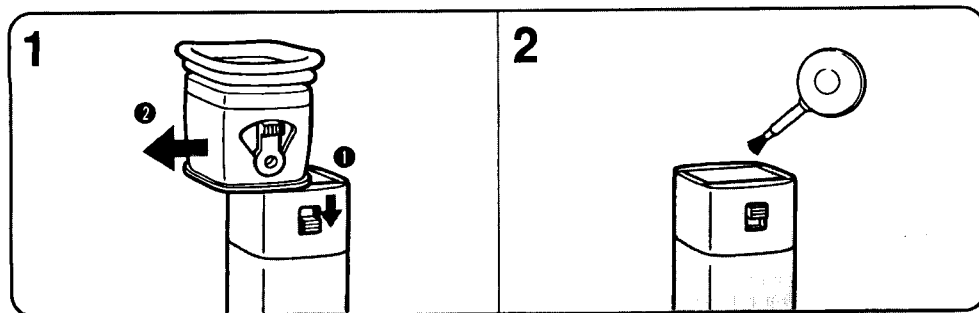

## Precautions

### Camcorder Operation

- Operate the camcorder on 6.0 V (battery pack) or 7.5 V (AC power adaptor).
- For DC or AC operation, use the accessories recommended in this manual.
- Should any solid object or liquid get inside the casing, unplug the camcorder and have it checked by qualified personnel before operating it any further.
- Do not pick up the camcorder by the viewfinder [a].
- Avoid rough handling or mechanical shock. Be particularly careful of the lens.
- Keep the POWER switch set to OFF when not using the camcorder.
- Do not wrap up the camcorder and operate it since heat may build up internally.
- Keep the camcorder away from strong magnetic fields or mechanical vibration.
- Do not let sand get into the camcorder. When you use the camcorder on a sandy beach or dusty place, protect it from the sand or dust. Sand or dust may cause the unit to malfunction and sometimes the malfunction cannot be repaired [b].
- Do not let the camcorder get wet. Keep the camcorder away from rain or sea water. It may cause the unit to malfunction and sometimes the malfunction cannot be repaired [c].

[a]

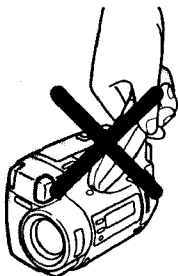

[b]

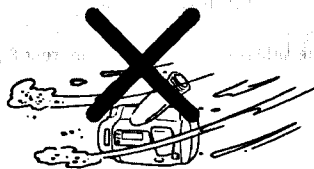

[c]

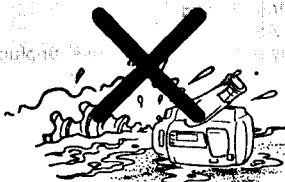

## Maintenance Information and Precautions

### On Handling Tapes

Do not insert anything in the small holes on the rear of the cassette. These holes are used to sense the type, thickness of tape, or if the tab is out or in, etc.

### Camcorder Care

- When the camcorder is not to be used for a long time, disconnect the power source and remove the tape. Periodically turn on the power, operate the camera and player sections and play back a tape for about 3 minutes.
- Clean the lens with a soft brush to remove dust. If there are fingerprints on it, remove them with a soft cloth.
- Clean the camcorder body with a dry soft cloth, or a soft cloth lightly moistened with a mild detergent solution. Do not use any type of solvent which may damage the finish.

### AC Power Adaptor

#### Charging

- **Repeated charging while some capacity remains causes a lowering of battery capacity. However, the original battery capacity can be recovered if you use the battery completely and charge it fully again.**
  - Charge the battery pack on a flat place without vibration.
  - The battery pack will get hot during charging. This is normal.
  - Video equipment cannot be operated while charging the battery pack.
- Do not continuously recharge a charged battery pack as that will cause the battery pack efficiency to deteriorate.**

#### Charging temperature

The temperature range for charging is 5°C to 35°C (41°F to 95°F). However, to provide maximum battery efficiency, the recommended temperature range when charging is 10°C to 30°C (50°F to 86°F).

#### Others

- The AC power cord should only be changed at a qualified service shop.
- The nameplate indicating operating voltage, power consumption, etc. is located on the bottom.
- A negligible amount of electric current will flow into the AC power adaptor (even with the selector in the center position) as long as the AC power adaptor is plugged into the wall outlet.
- Unplug the unit from the wall (mains) outlet when not in use for a long time. To disconnect the cord (mains lead), pull it out by the plug. Never pull the cord itself.
- Do not operate the unit with a damaged cord or if the unit has been dropped or damaged.
- Be sure that nothing metallic comes into contact with the metal parts of the connecting plate. If this happens, a short may occur and the unit may be damaged.
- Always keep the metal contacts clean.
- Do not disassemble the unit.
- Do not apply mechanical shock or drop the unit.
- While the unit is in use, particularly during charging, keep it away from AM receivers and video equipment because it will disturb AM reception and video operation.
- The unit becomes warm while in use. This is normal.
- Do not place the unit in locations that are:
  - Extremely hot or cold
  - Dusty or dirty
  - Very humid
  - Vibrating

If any difficulty should arise, unplug the unit and contact your nearest Sony dealer.

# Using Your Camcorder Abroad

Each country has its own electricity and TV color systems. Before using your camcorder abroad, check the following points.

## Power Sources

You can use your camcorder in any country with the supplied AC power adaptor within 110 V to 240 V AC, 50/60 Hz.

Use a commercially available AC plug adaptor [a], if necessary, depending on the design of the wall outlet [b].

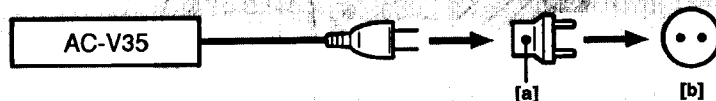

## Difference In Color Systems

This camcorder is an NTSC system based camcorder. If you want to view the playback picture on a TV, it must be an NTSC system based TV or a PAL-M system based TV with an NTSC/PAL-M transcoder. Check the following list.

### NTSC system countries

Bahama Islands, Bolivia, Canada, Central America, Chile, Colombia, Ecuador, Jamaica, Japan, Korea, Mexico, Peru, Surinam, Taiwan, the Philippines, the U.S.A., Venezuela, etc.

### PAL system countries

Australia, Austria, Belgium, China, Denmark, Finland, former West Germany, Great Britain, Holland, Hong Kong, Italy, Kuwait, Malaysia, New Zealand, Norway, Portugal, Singapore, Spain, Sweden, Switzerland, Thailand, etc.

### PAL-M system country

Brazil

### PAL-N system countries

Argentina, Paraguay, Uruguay

### SECAM system countries

Bulgaria, France, Guiana, Hungary, Iran, Iraq, Monaco, Poland, former Soviet Union, etc.

## Identifying the Parts

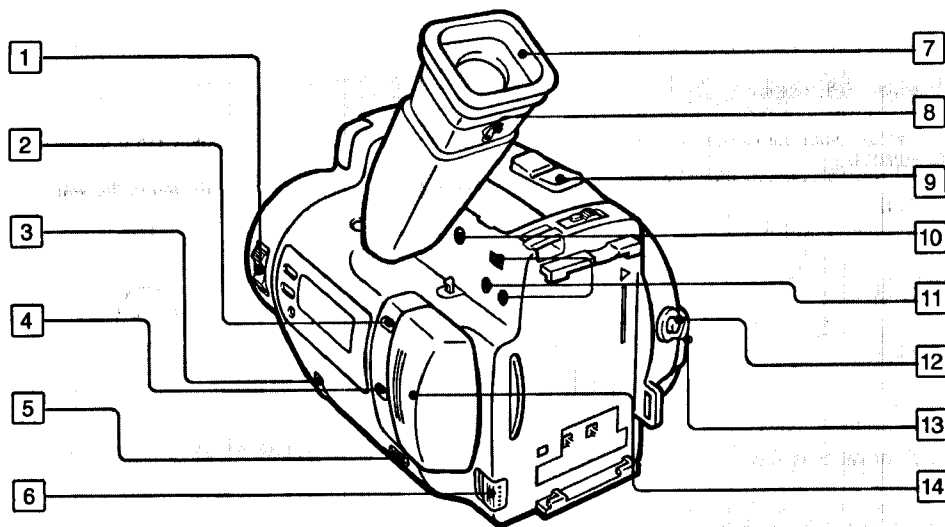

- 1 **POWER switch** (p. 16, 22)
- 2 **FOCUS button** (p. 27)
- 3 **Focus dial** (p. 27)
- 4 **PROGRAM AE button** (p. 29)
- 5 **STEADY SHOT switch** (p. 19)
- 6 **BATT (battery eject) knob** (p. 7)
- 7 **Eyecup**

- 8 **Viewfinder lens adjustment lever** (p. 14)
- 9 **Power zoom button** (p. 18)
- 10 **REC START/STOP button** (p. 15)
- 11 **Menu operation buttons** (p. 31)
- 12 **START/STOP button** (p. 16)
- 13 **STANDBY switch** (p. 16)
- 14 **AUTO LOCK cover** (p. 16, 25)



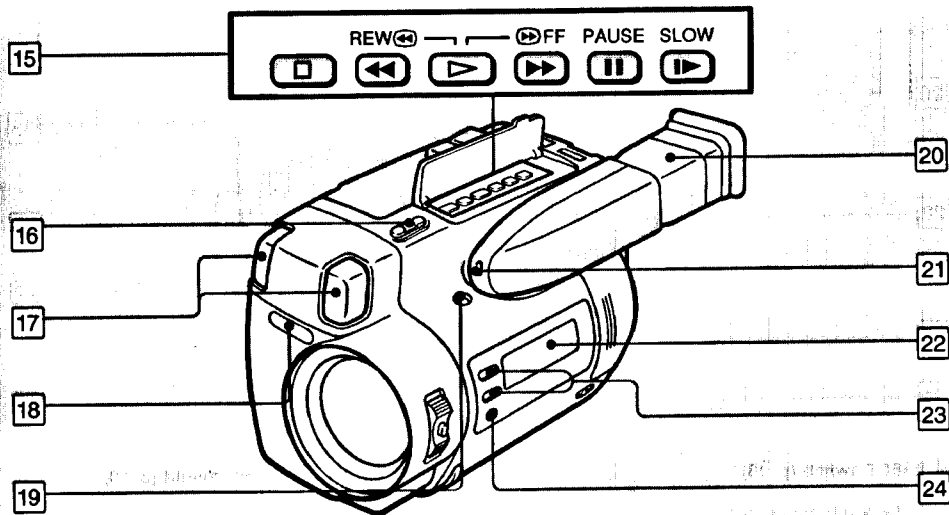

**15** **Tape transport buttons** (p. 22)

- (stop)
- ◀ REW (rewind)
- ▶ (playback)
- ▶▶ FF (fastforward)
- || PAUSE
- ▶ SLOW (slow playback)

**16** **EDITSEARCH button** (p. 20)

**17** **Built-in microphone (stereo)**

**18** **Remote sensor** (p. 45)

Aim the Remote Commander here for remote control.

**19** **FADER button**

**20** **Viewfinder** (p. 14, 16)

**21** **Camera recording/battery lamp**

**22** **Display window** (p. 43, 50)

**23** **DATE (+) and TIME (NEXT) buttons** (p. 12)

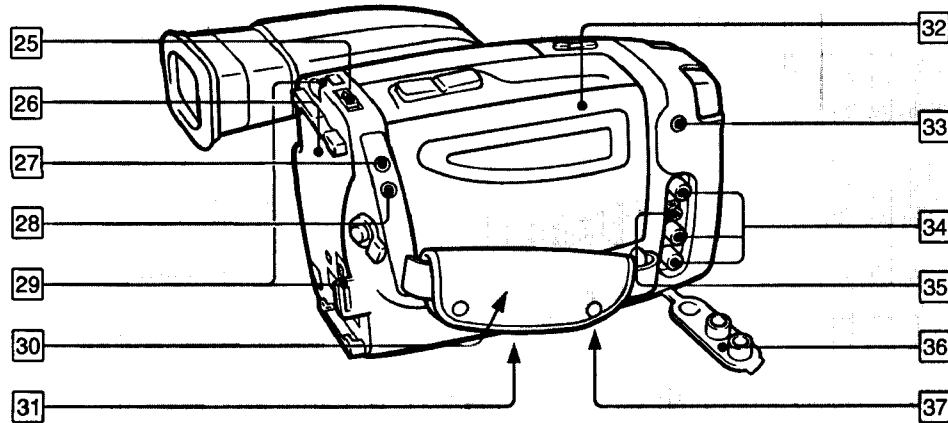

**24** **RESET button** (p. 17)

## Identifying the Parts



25 **EJECT switch** (p. 13)

26 **Battery mounting surface** (p. 7)

27 **REMOTE**  (LANC) control jack  
 stands for Local Application Control Bus System. The  control jack is used for controlling the tape transport of video equipment and peripherals connected to it. This jack has the same function as the jack indicated as CONTROL L or REMOTE.

28 **PHONES** (headphones) jack  
 (stereo mini jack)

29 **Hooks for shoulder strap** (p. 45)

30 **Grip strap** (p. 15)

31 **Lithium battery compartment** (p. 10)

32 **Cassette holder** (p. 13)

33 **MIC jack (PLUG IN POWER)**  
 Connect an optional external microphone (stereo or monaural). This jack also accepts a "plug-in-power" microphone.

34 **Audio/Video output jacks** (p. 21)

35 **RFU DC OUT (RFU adaptor DC output) jack**  
 (p. 21)

36 **Jack cover**



37 **Tripod receptacle** (p. 15)

## Operation Indicators

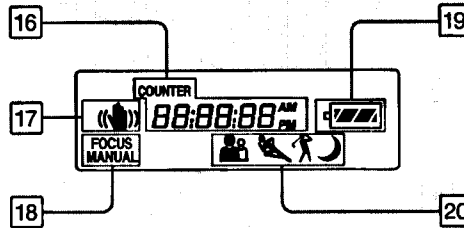
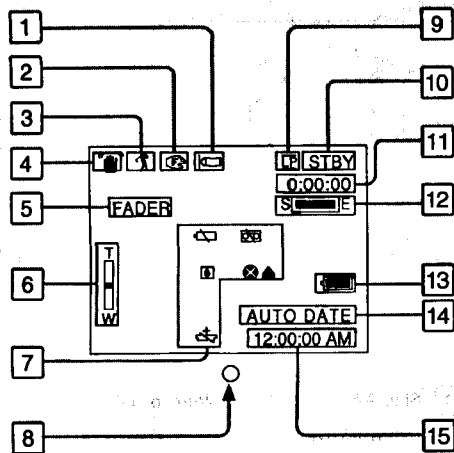
For details on each indicator, refer to the pages indicated in the parenthesis.



- 1 WIND indicator (p. 17)
- 2 Manual focusing (p. 27)
- 3 PROGRAM AE indicator (p. 28, 29)
- 4 STEADY SHOT indicator (p. 19)
- 5 FADER indicator (p. 30)
- 6 Power zoom indicator (p. 18)
- 7 Warning indicators (p. 50)
- 8 Recording lamp/Battery lamp
- 9 Lights up when playing back a tape recorded in LP mode.
- 10 Tape transport mode (p. 22)
- 11 Tape counter (p. 17)

- 12 Remaining tape indicator  

- 13 Remaining battery indicator (p. 8, 50)  

- 14 AUTO DATE indicator (p. 16, 17)
- 15 Date or Time (p. 12)
- 16 Tape counter, time or date indicator (p. 12, 17)
- 17 STEADY SHOT indicator (p. 19)
- 18 FOCUS MANUAL indicator (p. 27)
- 19 Remaining battery indicator (p. 8, 50)  

- 20 PROGRAM AE indicator (p. 28, 29)

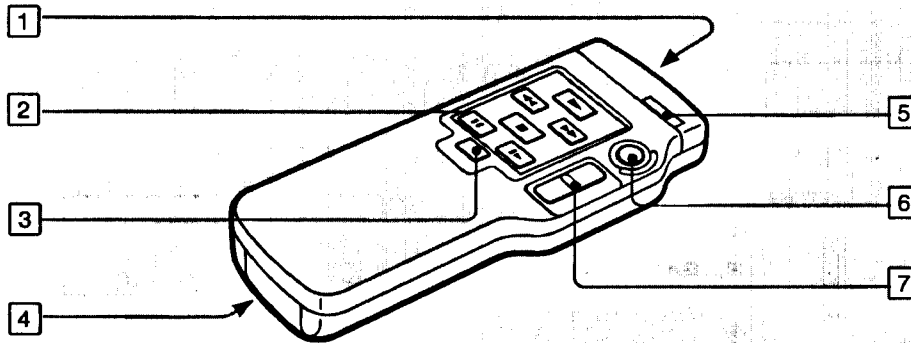
## Identifying the Parts

### Remote Commander

The buttons that have the same name on the Remote Commander and on the camcorder function identically.



**1 Transmitter**

Point toward the remote sensor to control the camcorder after turning on the POWER switch on the camcorder.

**2 Tape transport buttons**

**3 DISPLAY button**

**4 Size AA (R6) battery holder (p. 11)**

**5 HOLD Switch**

**6 START/STOP button**

**7 Power zoom button**

The zooming speed is unchangeable in the Remote Commander.

### Using the Remote Commander

Make sure that the COMMANDER mode is set to ON in the menu system on the camcorder, and that the HOLD switch on the Remote Commander is not working.

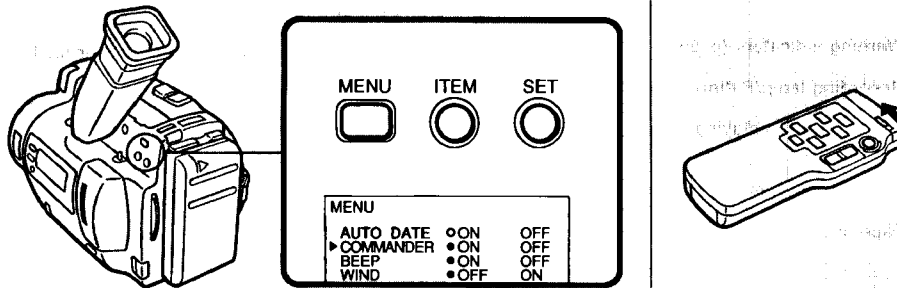

## Remote Control Direction

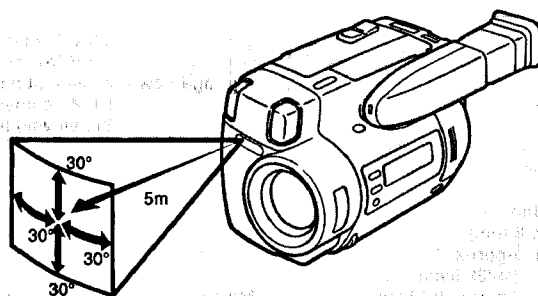

### Notes on the Remote Commander

- Keep the remote sensor away from strong light sources such as direct sunlight or illumination. Otherwise, the remote control may not be effective.
- Be sure that there is no obstacle between the remote sensor and the Remote Commander.
- This camcorder works at commander mode VTR 2. The commander modes (1, 2 and 3) are used to distinguish this camcorder from other Sony VCRs to avoid remote control misoperation. If you use another Sony VCR at commander mode VTR 2, we recommend you change the commander mode or cover the remote sensor of the VCR with black paper.

## Attaching the Shoulder Strap

Attach the supplied shoulder strap to the hooks for the shoulder strap (p. 42).

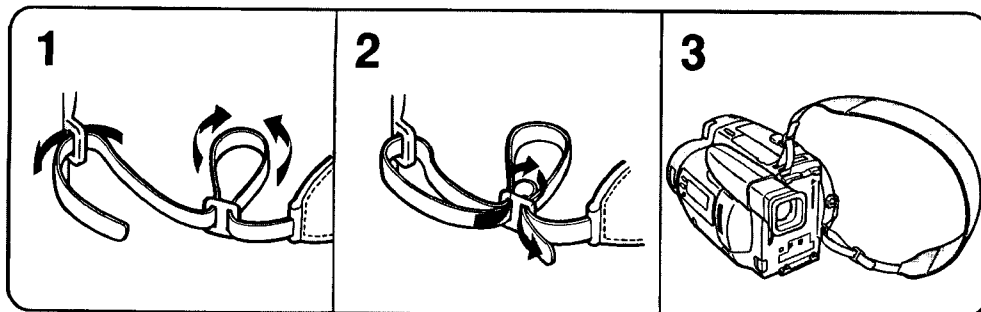

Identifying the Parts

# Specifications

## Video Camera Recorder

### System

Video recording system	Two rotary heads, Helical scanning FM system
Audio recording system	Rotary heads, FM system
Video signal	NTSC color, EIA standards
Usable cassette	8 mm video format cassette (standard 8 mm)
Tape speed	SP mode: Approx. 1.43 cm (19/32 inches)/second LP mode: Approx. 0.72 cm (5/16 inches)/second (playback only)
Recording time	SP mode: 2 hours (P6-120)
Playback time	SP mode: 2 hours (P6-120) LP mode: 4 hours (P6-120)
Fastforward/rewind time	Approx. 6 min. 30 sec. (P6-120)
Image device	CCD (Charge Coupled Device)
Viewfinder	Electronic viewfinder (color)
Lens	Combined 10 x power zoom lens f= 6.1 to 61 mm (1/4 to 2 7/16 inches) (44 to 440 mm when converted to a 35 mm still camera) F 1.6 to 3.1 Filter diameter 52 mm (2 1/8 inches) TTL autofocus system inner focus wide macro system
Colour temperature	Auto
Minimum illumination	1 lx (F 1.6)
Illumination range	1 lx to 100,000 lx
Recommended illumination	More than 100 lx
<b>Output connector</b>	
Video output	Phono jack, 1 Vp-p, 75 $\Omega$ , unbalanced, sync negative
Audio output	Phono jacks (2: stereo L and R) -7.5 dBs, (at output impedance 47 k $\Omega$ ) impedance less than 2.2 k $\Omega$
RFU DC OUT	Special minijack, DC 5 V
Headphones jack	Stereo minijack
Remote jack	Stereo mini-minijack ( $\varnothing$ 2.5 mm)
MIC jack	Stereo minijack, -66 dBs low impedance with 2.5 to 3 V DC, output impedance 6.8 k $\Omega$ ( $\varnothing$ 3.5 mm)

### General

Power requirements	On battery mounting surface 6.0 V (battery pack) 7.5 V (AC power adaptor)
Average power consumption	6.0 W (camera recording) including the viewfinder
Installation	Vertically, Horizontally
Operating temperature	0°C to 40°C (32°F to 104°F)
Storage temperature	-20°C to +60°C (-4°F to +140°F)
Dimensions	Approx. 109 x 109 x 197 mm (w/h/d) (4 3/8 x 4 3/8 x 7 4/8 inches)
Mass	About 920 g (2 lb) excluding the battery pack, lithium battery, cassette, and shoulder strap About 1140 g (2 lb 7 oz) including the battery pack NP-55H, lithium battery CR2025, cassette P6-120, and shoulder strap
Microphone	Electret condenser microphone, stereo type
Supplied accessories	See page 5.

### AC power adaptor

Power requirements	110-240 V AC*, 50/60 Hz
Power consumption	20 W
Output voltage	DC OUT: 7.5 V, 1.6 A in operating mode Battery charge terminal: 10 V, 1.3 A in charge mode
Application	Sony battery packs NP-55H, NP-60D, NP-66H, NP-77H/77HD, NP-80/80D
Operating temperature	0°C to 40°C (32°F to 104°F)
Storage temperature	-20°C to +60°C (-4°F to +140°F)
Dimensions	Approx. 170 x 41.6 x 82 mm (w/h/d) (6 3/4 x 1 11/16 x 3 1/4 inches) including projecting parts and controls
Mass	Approx. 520 g (18 oz)
	* Canadian Standard Association (CSA) certifies 120 V AC only.

Design and specifications are subject to change without notice.

# Trouble Check

If you run into any problem using the camcorder, use the following table to troubleshoot the problem. Should the difficulty persist, disconnect the power source and contact your Sony dealer or local authorized Sony service facility.

## Camcorder

	Symptom	Cause	Corrective Actions	page
Power	The power is not on.	The battery pack is not attached.	Attach the battery pack.	7
		The battery is dead.	Use a charged battery pack.	6
		The AC power adaptor is not connected to a wall outlet.	Connect the AC power adaptor to a wall outlet.	24
	The power goes off.	While being operated in CAMERA mode, the camcorder has been in the Standby mode for more than 5 minutes.	Turn STANDBY down once and turn it up again.	16
		The battery is dead.	Use a charged battery pack.	6
	The battery pack is quickly discharged.	The ambient temperature is too low.	—	8
		The battery pack has not been charged fully.	Charge the battery pack again.	6
		The battery pack is completely dead, and cannot be recharged.	Use another battery pack.	9
	Operation	START/STOP does not operate.	The tape is stuck to the drum.	Eject the tape.
The tape has run out.			Rewind the tape or use a new one.	22
The POWER switch is set to PLAYER.			Set it to CAMERA.	16
The tab on the cassette is out (red).			Use a new tape or slide the tab.	17
The cassette cannot be removed from the holder.		The battery is dead.	Use a charged battery pack or the AC power adaptor.	6 24
No function except for cassette ejection works.		Moisture condensation has occurred.	Remove the cassette and leave the camcorder for at least an hour.	35
The tape does not move when a tape transport button is pressed.		The POWER switch is set to CAMERA or OFF.	Set it to PLAYER.	22
		The tape has run out.	Rewind the tape or use a new one.	22
The STEADY SHOT function does not activate.		STEADY SHOT is set to OFF.	Set STEADY SHOT to ON.	19
The autofocusing function does not work.		The AUTO LOCK cover is open.	Close the AUTO LOCK cover.	16 25
		Shooting conditions are not suitable for autofocusing operation.	Open the AUTO LOCK cover and press FOCUS to adjust the focus manually.	27
No sound or only a low sound is heard when playing back a tape.		The stereo tape is played back with HiFi SOUND set to "1" or "2" in the menu system.	Set to "STEREO" in the menu system.	32

## Trouble Check

	Symptom	Cause	Corrective Actions	page
Picture	Excessive high-pitched sound is heard.	The picture has been recorded with WIND set to ON in the menu system.	When there is no wind, set the selector to OFF.	17
	The image on the viewfinder screen is not clear.	The viewfinder lens is not adjusted.	Adjust the viewfinder lens.	14
	A vertical band appears when a subject such as lights or a candle flame is shot against a dark background.	The contrast between the subject and background is too high.	The camcorder is not malfunctioning. Change locations.	—
	The menu is not displayed on the TV.	DISPLAY on the Remote Commander has not been pressed.	Press DISPLAY on the Remote Commander.	23
	The playback picture is not clear.	EDIT is set to ON in the menu system.	Set it to OFF.	34
	The picture is "noisy".	The video heads may be dirty.	Clean the heads using the Sony V8-25CLH cleaning cassette.	36
Others	The supplied Remote Commander does not work.	COMMANDER is set to OFF in the menu system.	Set it to ON.	44
		Something is blocking the infrared rays.	Remove the obstacle.	—
		The battery is not inserted with the correct polarity.	Insert the battery with the correct polarity.	11
		The battery is dead.	Insert a new one.	11
		The HOLD switch is working.	Set the switch in the opposite direction of the arrow.	44
	There is dust in the viewfinder.	—	Remove the viewfinder barrel and clean the viewfinder screen or viewfinder lens.	37



## AC Power Adaptor

	Symptom	Cause	Corrective Actions	page
AC power adaptor	The POWER lamp does not light.	—	Set the selector to the center position and disconnect the power cord. After about one minute, reconnect the power cord and set the selector to CHARGE again.	6
	The CHARGE lamp flashes.	See the following chart.		

### When the CHARGE Lamp Flashes

Check through the following chart.

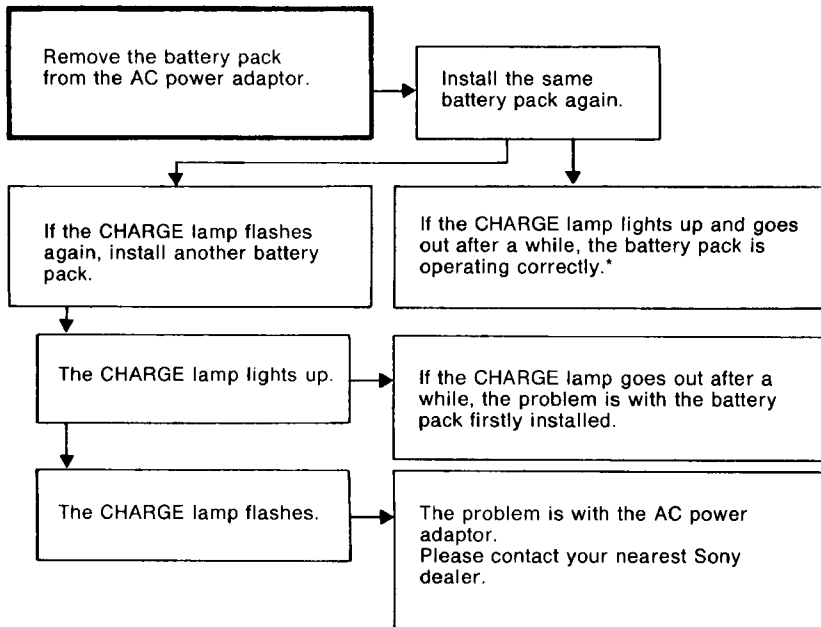

\* If you use a battery pack which you have just bought or which has been left unused for a long time, the CHARGE lamp may flash at the first charging. But this is not a problem. Repeat again to charge with the same battery pack.

# Indicators in the Viewfinder and the Display Window

## Warning Indicators

If indicators flash in the viewfinder and in the display window or a caution lamp on the camcorder flashes, check the following:

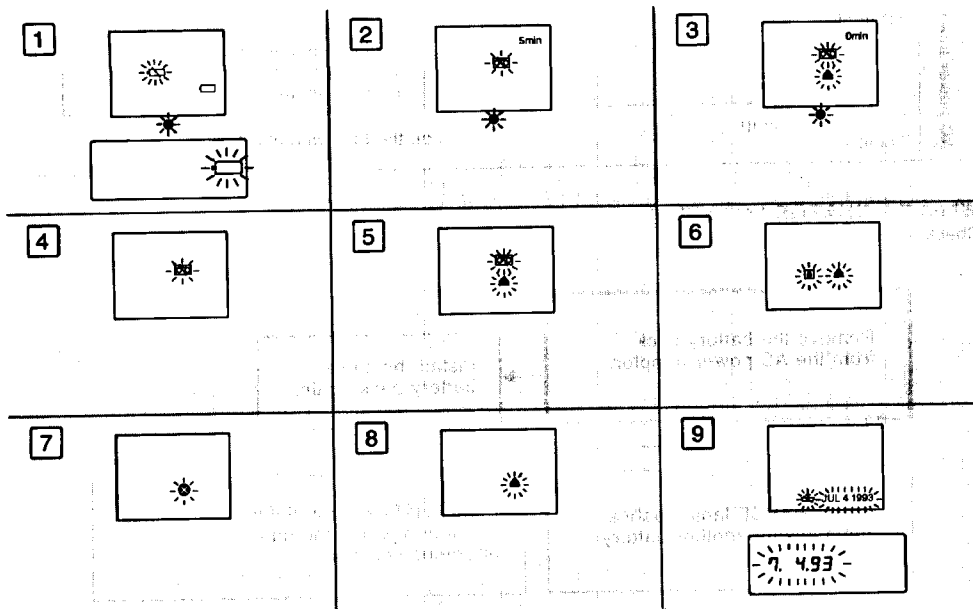

- 1 The battery is weak or dead.  
Slow flashing: The battery is weak.  
Fast flashing: The battery is dead.
- 2 The tape is near the end.  
The flashing is slow.
- 3 The tape has run out.  
The flashing becomes rapid.
- 4 No tape has been inserted.
- 5 The tab on the tape is out (red).
- 6 Moisture condensation has occurred. (p. 35)
- 7 The video heads may be contaminated. (p. 36)
- 8 Some other trouble has occurred.  
Disconnect the power source and contact your Sony dealer or local authorized facility.
- 9 The lithium battery is weak or is not installed. (p. 11)

## A

AC power adaptor .....	6, 24
Adjusting viewfinder .....	14
AFM Hi-Fi Sound .....	35
AUTO DATE .....	16
Auto focus .....	27
AUTO LOCK .....	25
A/V connecting cable .....	21

## B

Battery pack .....	6
BEEP .....	32

## C

Camera recording .....	16
Car battery .....	24
Charging battery .....	6
Cleaning video heads .....	36
Clock set .....	12
Connection .....	21

## D, E

DATE/TIME .....	12
DISPLAY .....	23
EDIT .....	34
Editing .....	33
EDITSEARCH .....	20
EJECT .....	13

## F, G, H

FADER .....	30
Fade-in/Fade-out .....	30
Fastforward .....	22
High-speed shutter mode .....	28
HOLD .....	22

## I, J, K, L

LANC  .....	42
Lithium battery .....	10

## M, N, O, P

Manual focus .....	26
Menu system .....	31
M. FADER .....	30
MIC (microphone) jack .....	42
Playback on TV .....	21
Playback pause .....	23
Portrait mode .....	28
Power sources .....	24
Power zoom .....	18
PROGRAM AE .....	28

## Q, R

Rec review .....	20
Remote Commander .....	44
Remote control jack .....	42
RESET .....	17
Rewind .....	22
RFU adaptor .....	21

## S

Shoulder strap .....	45
Skip scan .....	23
Sports mode .....	28
STANDBY .....	16
Standby mode .....	16
STEADY SHOT .....	19
Supplied accessories .....	5

## T, U, V

Tape counter .....	17, 43
Tripod mounting .....	15
Trouble check .....	47
Twilight mode .....	28

## W, X, Y, Z

WIND .....	17
Zoom .....	18

---

If you have any question about this product, call:

**Sony Customer Information Center**

East Coast: 201-930-7669 (SONY) NJ

Central: 708-250-7669 (SONY) IL

West Coast: 714-821-7669 (SONY) CA

or write to:

**Sony Customer Information Center**

Sony Drive, Mail Drop #T1-11,

Park Ridge, NJ 07656

---