

SONY®

3-5+00-005
3-758-475-21 (1)

Video Camera Recorder 8

CCD-TR42/TR70/TR72/TR80/TR82

Operation Manual

Before operating the unit, please read this manual thoroughly, and retain it for future reference.

Owner's Record

The model and serial numbers are located on the bottom. Record the serial number in the space provided below. Refer to these numbers whenever you call upon your Sony dealer regarding this product.

Model No. CCD- _____ Model No. AC-V _____
Serial No. _____ Serial No. _____

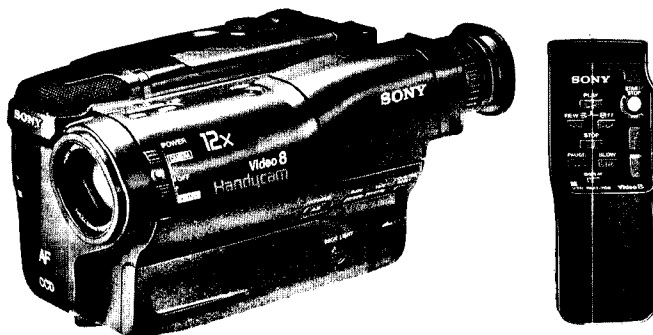

Photo: CCD-TR42

Video 8 Handycam

©1994 by Sony Corporation

Welcome to Video 8

Congratulations on your purchase of this Sony Handycam™ camcorder. With your Handycam, you can capture life's precious moments with superior picture and sound quality. Your Handycam is loaded with advanced features, but at the same time it is very easy to use. You will soon be producing home video that you can enjoy for years to come.

WARNING

To prevent fire or shock hazard,
do not expose the unit to rain or
moisture.

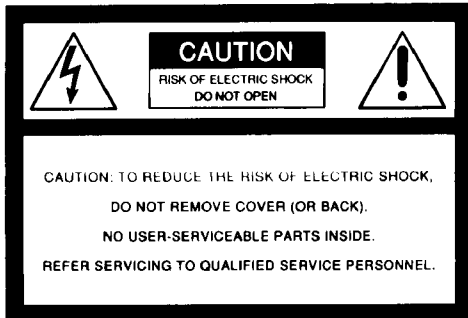

This symbol is intended to alert the user to the presence of uninsulated "dangerous voltage" within the product's enclosure that may be of sufficient magnitude to constitute a risk of electric shock to persons.



This symbol is intended to alert the user to the presence of important operating and maintenance (servicing) instructions in the literature accompanying the appliance.

RECYCLING NICKEL-CADMIUM BATTERIES



Ni-Cd

**NICKEL-CADMIUM BATTERY.
MUST BE DISPOSED OF PROPERLY.**

Nickel-Cadmium batteries are recyclable. You can help preserve our environment by returning your unwanted batteries to your nearest Sony Service Center or Factory Service Center for collection, recycling or proper disposal.

Note: In some areas the disposal of nickel-cadmium batteries in household or business trash may be prohibited.

For the Sony Service Center nearest you call
1-800-222-SONY (United States only)
For the Factory Service Center nearest you call
416-499-SONY (Canada only)

**Caution: Do not handle damaged or leaking
nickel-cadmium batteries.**

For the Customers in the U.S.A.

WARNING

This equipment has been tested and found to comply with the limits for a Class B digital device, pursuant to Part 15 of the FCC Rules. These limits are designed to provide reasonable protection against harmful interference in a residential installation. This equipment generates, uses, and can radiate radio frequency energy and, if not installed and used in accordance with the instructions, may cause harmful interference to radio communications. However, there is no guarantee that interference will not occur in a particular installation. If this equipment does cause harmful interference to radio or television reception, which can be determined by turning the equipment off and on, the user is encouraged to try to correct the interference by one or more of the following measures:

- Reorient or relocate the receiving antenna.
- Increase the separation between the equipment and receiver.
- Connect the equipment into an outlet on a circuit different from that to which the receiver is connected.
- Consult the dealer or an experienced radio/TV technician for help.

You are cautioned that any changes or modifications not expressly approved in this manual could void your authority to operate this equipment.

For the Customers in CANADA

This apparatus complies with the Class B limits for radio noise emissions set out in Radio Interference Regulations.

CAUTION

TO PREVENT ELECTRIC SHOCK, DO NOT USE THIS POLARIZED AC PLUG WITH AN EXTENSION CORD, RECEPTACLE OR OTHER OUTLET UNLESS THE BLADES CAN BE FULLY INSERTED TO PREVENT BLADE EXPOSURE.

Table of Contents

Before You Begin

- Checking Your Model Number 4
- Checking Supplied Accessories 5

Getting Started

- Charging and Installing the Battery Pack 6
- Inserting a Cassette 9
- Adjusting the Viewfinder Lens 10

Basic Operations

- Camera Recording 11
 - Using the Zoom Feature 13
- Hints for Better Shooting 14
- Checking the Recorded Picture 15
- Connections for Playback 16
 - Connecting to a TV without Video/Audio Input Jacks 16
 - Connecting to a TV with Video/Audio Input Jacks or VCR 16
- Playing Back a Tape 17

Advanced Operations

- Using Alternate Power Sources 19
 - Using House Current 19
- Recording with the Date or Time 20
- Shooting with Backlighting 21
- Using the PROGRAM AE Function 22
- Fade-in and Fade-out 23
- Releasing the Steady Shot Function (CCD-TR82 only) 24
- Changing the Mode Settings 25
 - Using the World Clock 27
- Editing onto Another Tape 29

Additional Information

- Changing the Lithium Battery in the Camcorder 30
- Resetting the Date and Time 31
- Playback Modes 33
- Tips for Using the Battery Pack 33
- Maintenance Information and Precautions 36
- Using Your Camcorder Abroad 39
- Trouble Check 40
- Specifications 43
- Identifying the Parts 45
- Warning Indicators 51
- Index (Back cover)

Checking Your Model Number

The instructions in this manual are for five models listed below. Before you start reading and operating, check your model number by looking at the bottom of your camcorder. The CCD-TR42 is the model used for illustration purposes. Otherwise, the model name is indicated in the illustrations. Any differences in operation are clearly indicated in the text, for example, "CCD-TR82".

As you read through this manual, buttons and settings on the camcorder are shown in capital letters. e.g. Set the POWER switch to CAMERA.

Types of Differences

Model Number	Audio		Viewfinder		Steady Shot	Zoom (X)
	Monaural	Stereo	B/W	Color		
CCD-TR42	○		○			12
CCD-TR70	○			○		10
CCD-TR72		○	○			12
CCD-TR80		○		○		12
CCD-TR82	○		○		○	12

Note on TV Color Systems

TV color systems differ from country to country.

To view your recordings on a TV, you need an NTSC system based TV. When you want to use a PAL-M system based TV, you will need a NTSC/PAL-M transcoder (as this is an NTSC system based camcorder). Please check the list on page 39 to see the TV color system of your country.

Note on the Supplied RFU adaptor

You can use the supplied RFU adaptor only in the country where you bought this camcorder. Since each country has its own electricity and TV color system, you may not be able to use the RFU adaptor when you use the camcorder abroad.

Precaution on Copyright

Television programs, films, video tapes, and other materials may be copyrighted. Unauthorized recording of such materials may be contrary to the provision of the copyright laws.

Precautions on Camcorder Care

- Do not let sand get into the camcorder. When you use the camcorder on a sandy beach or dusty place, protect it from the sand or dust. Sand or dust may cause the unit to malfunction and sometimes the malfunction cannot be repaired. [a]
- Do not let the camcorder get wet. Keep the camcorder from rain or sea water. It may cause a malfunction and sometimes the malfunction cannot be repaired. [b]
- Never leave the camcorder under temperatures above 140°F (60°C), such as in a car parked in the sun or under direct sunlight. [c]

[a]

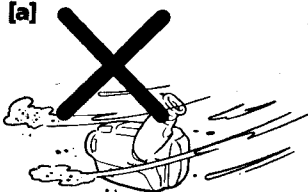

[b]

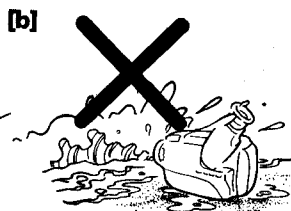

[c]

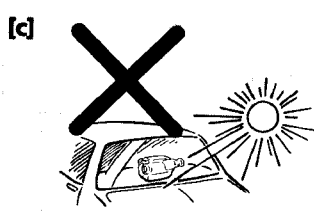

Checking Supplied Accessories

Check that the following accessories are supplied with your camcorder.

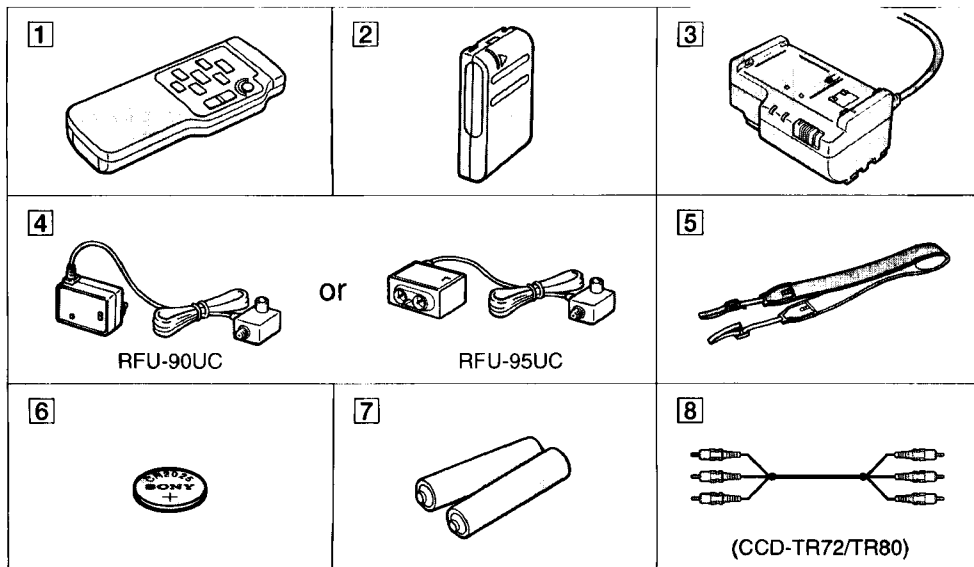

Checking Your Model Number/Checking Supplied Accessories

- 1** Wireless remote commander (1) (p.17, 48)
- 2** NP-55 Battery pack (1) (p.6, 33)
- 3** AC-V25/V25A/V25B AC power adaptor (1) (p.6, 19)
- 4** RFU-90UC/95UC RFU adaptor (1) (p.16)
- 5** Shoulder strap (1) (p.46)
- 6** CR2025 Lithium Battery (1) (p.30)
Already installed in the camcorder.
- 7** Size AA (R16) Battery for Remote Commander (2) (p.48)
- 8** A/V connecting cable (1) (p.16)
For CCD-TR72/TR80 only

Charging and Installing the Battery Pack

Before using your camcorder, you first need to charge and install the battery pack. To charge the battery pack, use the supplied AC-V25/V25A/V25B AC power adaptor.

Charging the Battery Pack

Charge the battery pack on a flat place without vibration.

(1) Connect the AC power adaptor to a wall outlet. **(2)** Align the right side of the battery pack with the line on the AC power adaptor, then slide the battery pack in the direction of the arrow. **(3)** Set the selector to CHARGE. The POWER lamp (green) and the CHARGE lamp (orange) light up. Charging begins.

When charging is completed, the CHARGE lamp goes out. Set the selector to the center position and unplug the unit from the wall outlet. Then remove the battery pack and install it on the camcorder. To stop charging, set the selector to the center position.

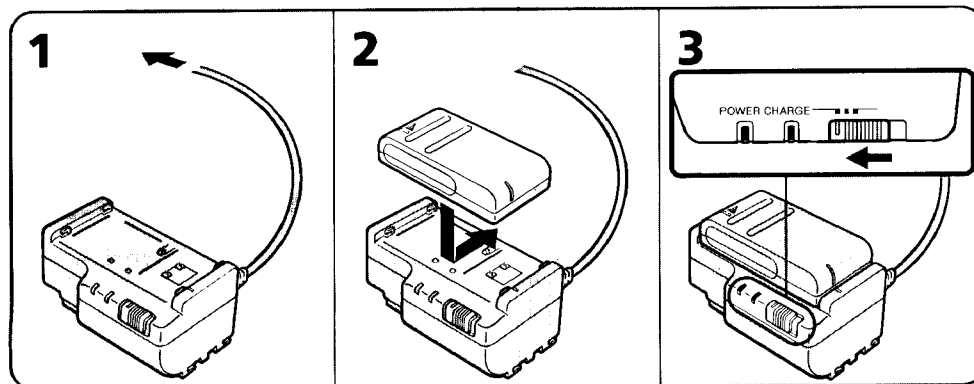

Charging Time

Battery pack	NP-55 (supplied)	NP-80 NP-80D	NP-77H	NP-66H	NP-60D	NP-55H
Charging time*	70	180	160	120	90	80

* Approximate minutes to charge an empty pack using the AC-V25/V25A/V25B (Lower temperatures require a longer charging time.)

Battery Life

CCD-TR42/TR72

Battery Pack	NP-55	NP-80/ 80D	NP-77H	NP-66H	NP-60D	NP-55H
Typical recording time**	35	95	85	65	45	40
Continuous recording time***	65	180	160	120	85	75

CCD-TR70/TR80

Battery pack	NP-55	NP-80/ 80D	NP-77H	NP-66H	NP-60D	NP-55H
Typical recording time**	30	90	80	60	40	35
Continuous recording time***	60	170	150	110	80	70

CCD-TR82

Battery pack	NP-55	NP-80/ 80D	NP-77H	NP-66H	NP-60D	NP-55H
Typical recording time**	30	85	75	55	40	35
Continuous recording time***	55	165	145	105	75	65

** Approximate minutes when recording while you repeat recording start/stop, zooming and turning the power on/off. The actual battery life may be shorter.

*** Approximate continuous recording time indoors.

Important!

Use the battery completely before re-charging!

Before you recharge the battery, make sure the battery has been used up (discharged) completely. Repeated charging while some capacity remains causes a lowering of battery capacity. However, the original battery capacity can be recovered if you use the battery completely and charge it fully again.

To use up the battery, remove the cassette and slide the POWER switch to CAMERA with the battery attached, and leave the camcorder until the  indicator and the red lamp flash rapidly in the viewfinder.

Removing the Battery Pack

Slide the battery pack in the direction of the arrow.

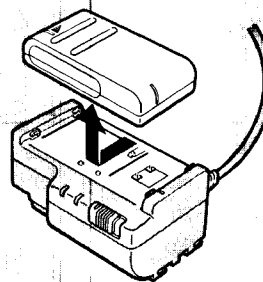

Notes on charging the battery pack

- The POWER lamp will remain lit for a while even if the battery pack is removed and the power cord is unplugged after charging the battery pack. This is normal.
- If the POWER lamp does not light, set the selector to the center position and disconnect the power cord. After about one minute, reconnect the power cord and set the selector to CHARGE again.
- You cannot operate the camcorder using the AC power adaptor while charging the battery pack.

Charging and Installing the Battery Pack

Installing the Battery Pack

(1) Lift up the viewfinder. (2) Align the right side of the battery pack with the white line on the camcorder, and slide the battery pack to the right.

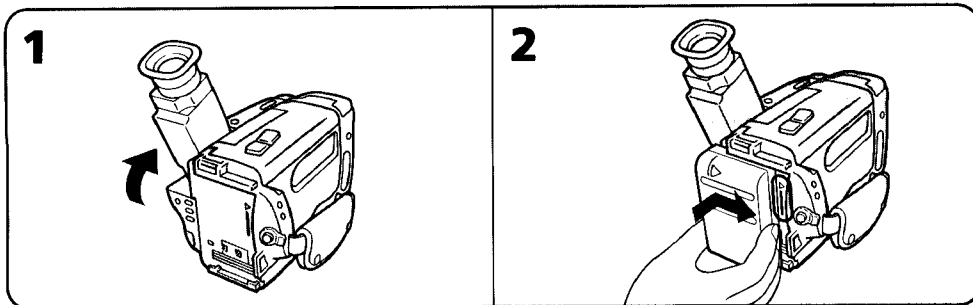

Removing the Battery Pack

(1) Lift up the viewfinder. (2) While pressing BATT, slide the battery pack to the left.

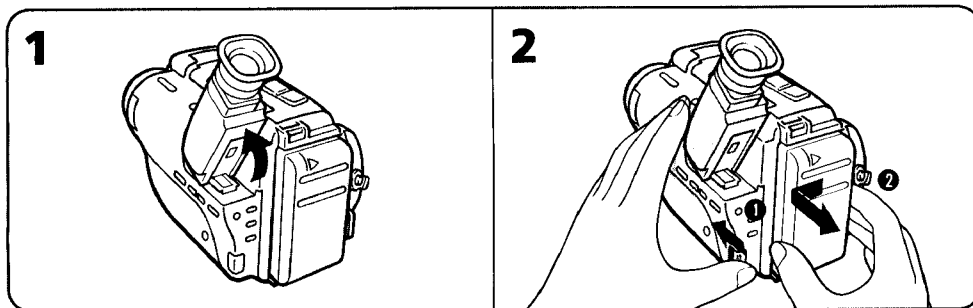

Inserting a Cassette

Make sure that a power source is installed.

- (1) While sliding the lid lock, lift up the lid. Then open it.
- (2) Press EJECT. The cassette compartment automatically lifts up and opens.
- (3) Insert a cassette (not supplied) with the window facing out.
- (4) Press the PUSH mark on the cassette compartment to close it. The cassette compartment automatically goes down.
- (5) Close the lid until it locks.

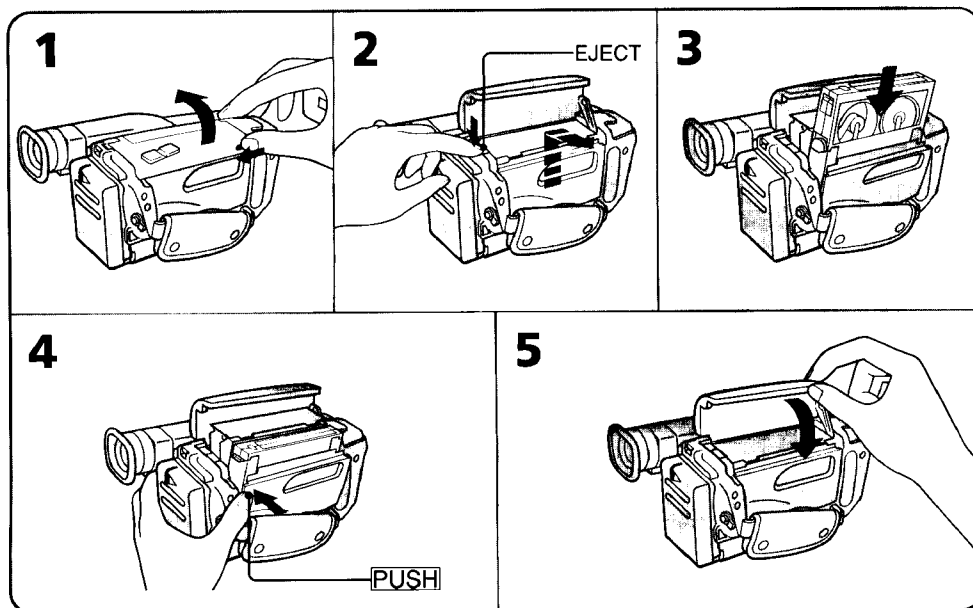



Charging and Installing the Battery Pack/Inserting a Cassette

To Eject the Cassette

Press EJECT.

To Prevent Accidental Erasure

Slide the tab on the cassette to expose the red mark.

If you try to record with the red mark exposed, the  and  indicators flash in the viewfinder, and you cannot record on the tape. To re-record on this tape, slide the tab back out to cover the red mark.

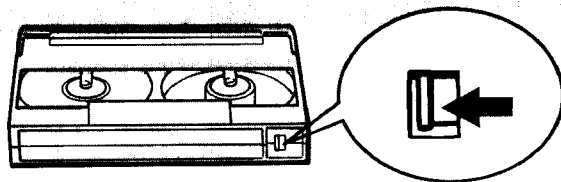

Adjusting the Viewfinder Lens

Before you use the camcorder for the first time or after someone else has used it, focus the viewfinder lens. Make sure that the power source is connected to the camcorder.

(1) While pressing the small green button on the POWER switch, slide it to CAMERA. **(2)** Turn STANDBY up. **(3)** Turn the viewfinder lens adjustment ring so that the indicators in the viewfinder come into sharp focus.

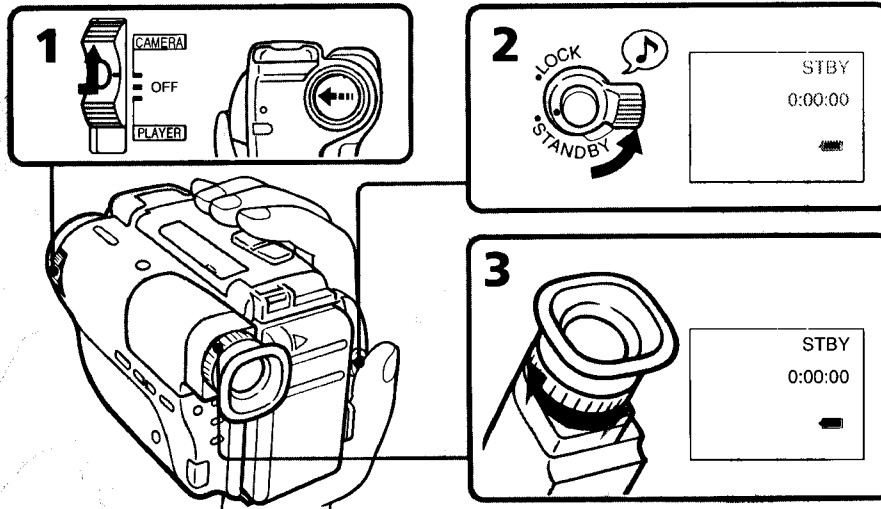

Camera Recording

Make sure that a power source and a cassette is inserted. The date is automatically recorded for 10 seconds after you start recording (AUTO DATE feature). This feature works only once a day. You can hear the beep sound to confirm your operation. Before you record one-time events, you may want to make a trial recording to make sure that you are using the camcorder correctly.

(1) While pressing the small green button on the POWER switch, slide it to CAMERA. **(2)** Turn STANDBY up. **(3)** Press START/STOP. The camcorder starts recording and the "REC" indicator appears in the viewfinder.

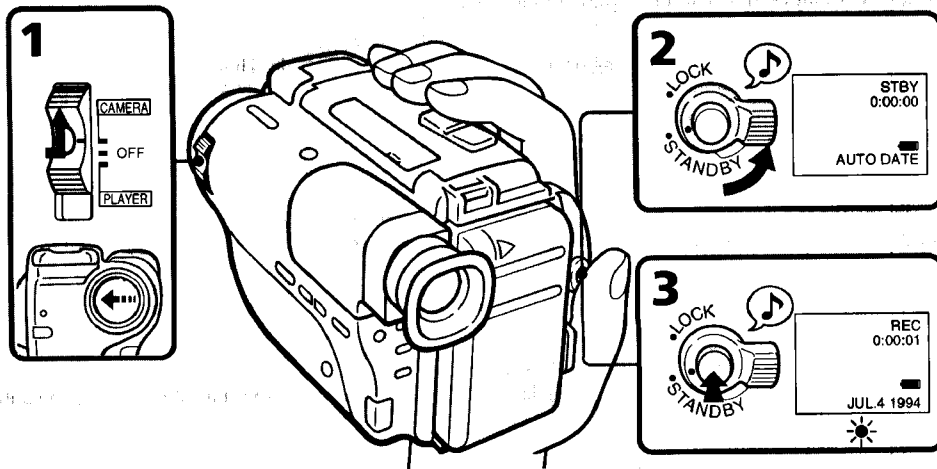

Note on beep sound

As indicated with  in the illustrations, a beep sounds when you turn the power on or when you start recording and two beeps sound when you stop recording, confirming the operation. Several beeps also sound as a warning of any unusual condition of the camcorder (p.51). Note that the beep sound is not recorded on the tape. If you do not want to hear the beep sound, select "OFF" in the menu system (p.25).

To Stop Recording Momentarily [a]

Press START/STOP again. The "STBY" indicator appears in the viewfinder (Standby mode).

To Finish Recording [b]

Press START/STOP. Turn STANDBY down, and set the POWER switch to OFF. Then, eject the cassette (p.9).

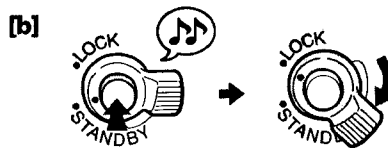
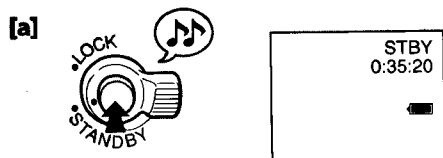

Adjusting the Viewfinder Lens / Camera Recording

Camera Recording

Note on Standby mode

If you leave the camcorder for 5 minutes or more with a cassette inserted in Standby mode, the camcorder goes off automatically. This prevents wearing down the battery and wearing out the tape. To resume Standby mode, turn STANDBY down once and turn it up again. To start recording, press START/STOP.

Note on recording

When you record from the beginning of the tape, run the tape for about 15 seconds before actual recording. This prevents the camcorder from missing any start-up scenes when you play back the tape. You can record tapes in SP (standard play) mode only.

Note on the tape counter

The tape counter indicates the recording or playback time. Use it as a guide. There will be a time lag of several seconds from the actual time. To set the counter to zero, press COUNTER RESET located below the viewfinder. You can know the approximate remaining tape by the remaining tape indicator (p.50).

Note on the AUTO DATE feature

The clock is set to the East Coast Standard Time at the factory. You can reset the clock (p.31).

You can change the AUTO DATE setting by selecting ON or OFF in the menu system (p.25).

- The AUTO DATE feature works once a day. However, the date may automatically appear more than once a day when:
 - you reset the date and time.
 - you eject and insert the tape again.
 - you stop recording within 10 seconds.
 - you set AUTO DATE to OFF once and set to ON in the menu system.
- Once the AUTO DATE feature turns off the date display 10 seconds after the start of recording, the date and time are displayed as follows:
 - if the date display setting has been made, the date is displayed.
 - if the time display setting has been made, the time is displayed.
 - if neither display setting has been made, nothing is displayed.

When moving from indoors to outdoors (or vice versa)

Turn STANDBY up and point the camcorder at a white object for about 15 seconds so that the white balance is properly adjusted.

Using the Zoom Feature

Zooming is a recording technique that lets you change the size of the subject in the scene. For more professional-looking recordings, use the zoom sparingly.

T side: for telephoto (subject appears closer)

W side: for wide-angle (subject appears farther away)

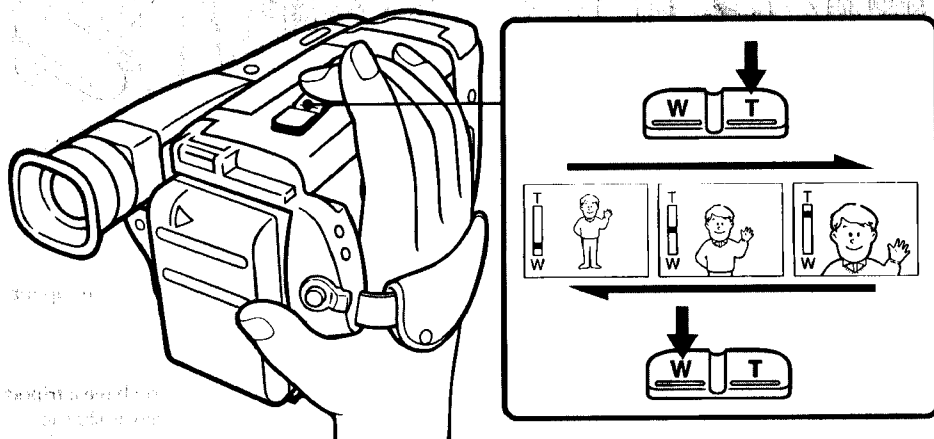

Camera Recording

Zooming Speed

Press the power zoom button firmly for a high-speed zoom. Press it softly for a relatively slow zoom.

When you shoot a subject using a telephoto zoom

If you cannot get a sharp focus while in extreme telephoto zoom, press the W side of the power zoom button until the focus is sharp.

You can shoot a subject that is at least 3.3 feet (about 1 m) away from the lens surface in the telephoto position, or 1/2 inches (about 1cm) in the wide-angle position.

Hints for Better Shooting

For hand-held shots, you'll get better results holding the camcorder according to the following suggestions:

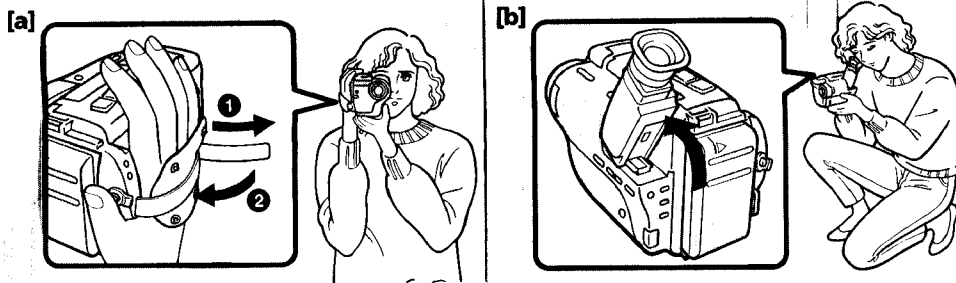

- Hold the camcorder firmly and secure it with the grip strap so that you can easily manipulate the controls with your thumb. **[a]**
- Place your right elbow against your side.
- Place your left hand under the camcorder to support it.
- Place your eye firmly against the viewfinder eyecup.
- Use the viewfinder frame as a guide to determine the horizontal plane.
- You can also record in a low position to get an interesting recording angle. Turn the viewfinder up for recording from a low position. **[b]**

Place the camcorder on a flat surface or use a tripod.

Try placing the camcorder on a table top or any other flat surface of suitable height. If you have a tripod for a still camera, you can also use it with the camcorder (p.46). Make sure the tripod screw is shorter than 9/32 in (6.5mm).

To Use the Viewfinder as a Sports Finder [c]

With the sports finder, you can monitor the picture while your eye is at a distance from the eyecup. The sports finder is convenient when moving around to shoot scenes. While sliding the viewfinder release knob to the left, flip open the viewfinder.

Note on the color viewfinder (for CCD-TR70/TR80)

You may find it difficult to use the color viewfinder as the sports finder for recording in light location.

Cautions on the viewfinder

- Do not pick up the camcorder by the viewfinder. **[d]**
- Do not place the camcorder so as to point the viewfinder toward the sun. The inside of the viewfinder may be deformed. Be careful in placing the camcorder under sunlight or at the window. **[e]**

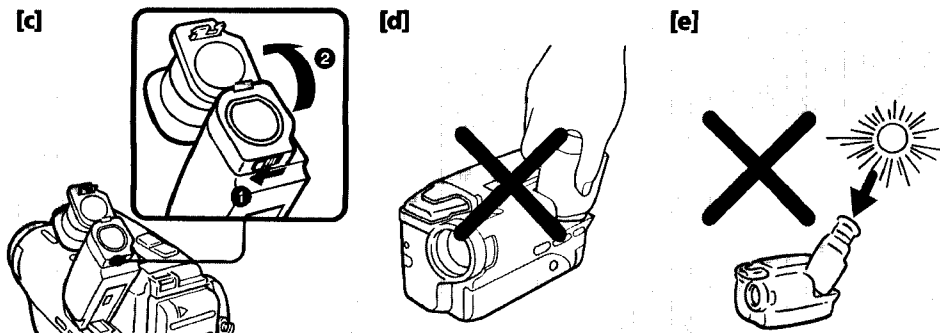

Checking the Recorded Picture

Using EDITSEARCH, you can review the last recorded scene or check the recorded picture in the viewfinder.

(1) While pressing the small green button on the POWER switch, slide it to CAMERA.

(2) Turn STANDBY up. **(3)** Press EDITSEARCH. Press the - (⊖) side momentarily, the last few seconds of the recorded portion plays back (**Rec Review**).

Keep pressing EDITSEARCH to play back the last recorded portion (**Edit Search**).

+ side: to view the forward playback picture

- side: to view the reverse playback picture

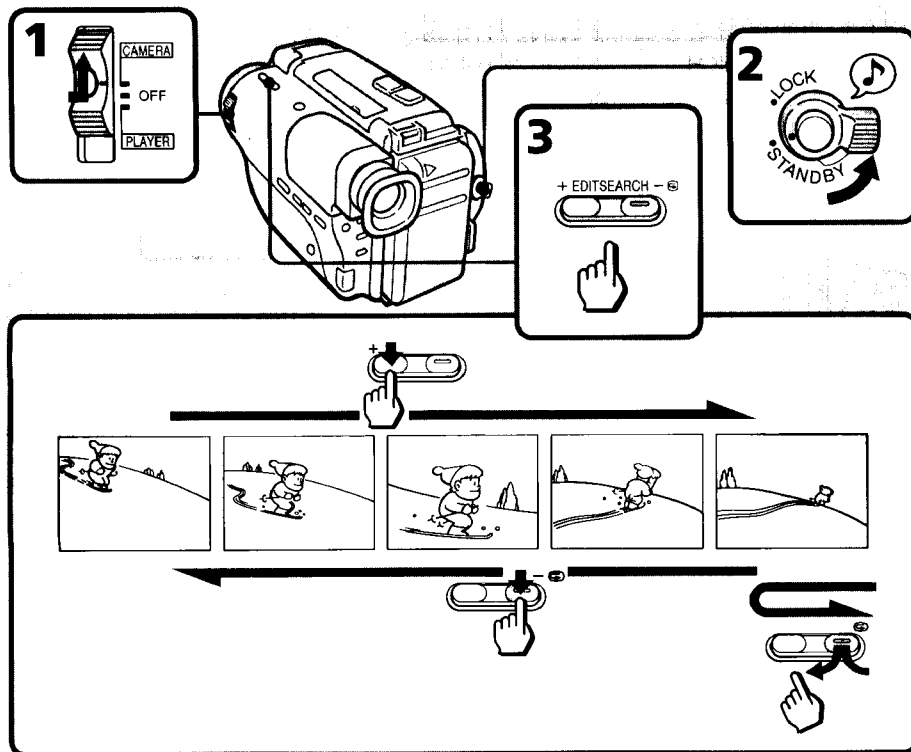

Hints for Better Shooting / Checking the Recorded Picture

To Stop Playback

Release EDITSEARCH.

To Begin Re-recording

Press START/STOP. Re-recording begins from the point you released EDITSEARCH. Provided you do not eject the tape, the transition between the last scene you recorded and the next scene you record will be smooth.

Monitoring the Sound While Viewing the Playback Picture in the Viewfinder

Connect earphone/headphones (not supplied) to the Ⓜ/🔊 jack. Play back the tape in PLAYER mode (p.17).

Connections for Playback

You can use this camcorder as a VCR by connecting it to your TV for playback. There are some ways to connect your camcorder as shown below. It is recommended to use the house current as the power source (p.19).

Connecting to a TV without Video/Audio Input Jacks

Connect the camcorder to the TV using the supplied RFU adaptor. Set the channel selector on the RFU adaptor and your TV channel to VHF channel CH3 or CH4, whichever is not active in your area. With this connection, the sound is monaural.

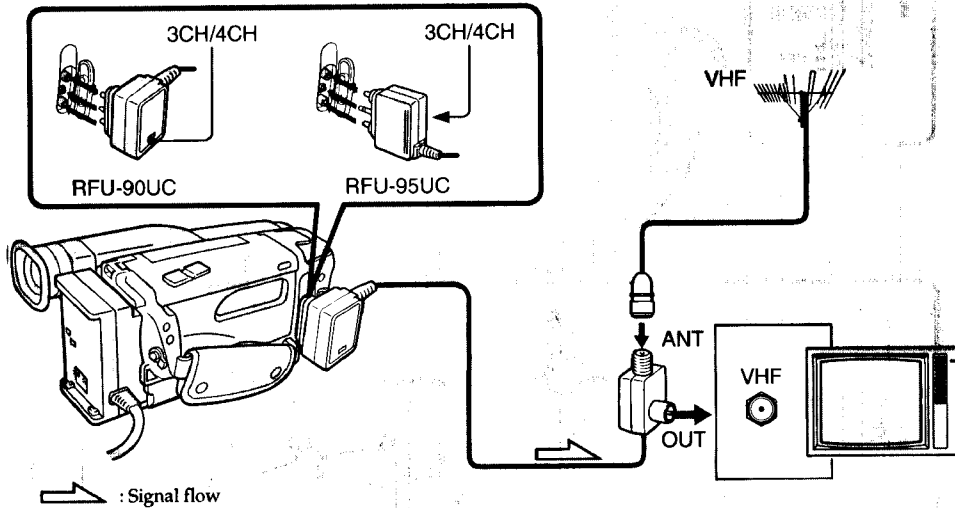

Connecting to a TV with Video/Audio Input Jacks or VCR

For Stereo Models (CCD-TR72/TR80)

Connect the camcorder to your TV by using the supplied connecting cable. Set the TV/VCR selector to VCR on the TV. When connecting the camcorder to VCR, set the input selector on the VCR to LINE.

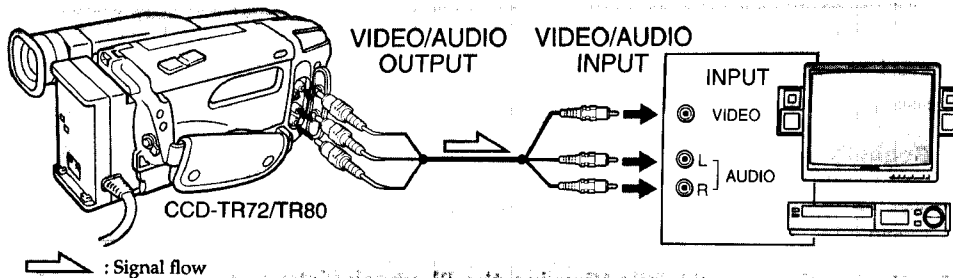

If your TV or VCR is monaural type, connect only the white plug for audio on both the camcorder and the TV or the VCR. With this connection, the sound is monaural.

For Monaural Models (CCD-TR42/TR70/TR82)

Connect the camcorder to your TV by using a monaural A/V connecting cable (not supplied). Set the TV/VCR selector to VCR on the TV. When connecting the camcorder to VCR, set the input selector on the VCR to LINE.

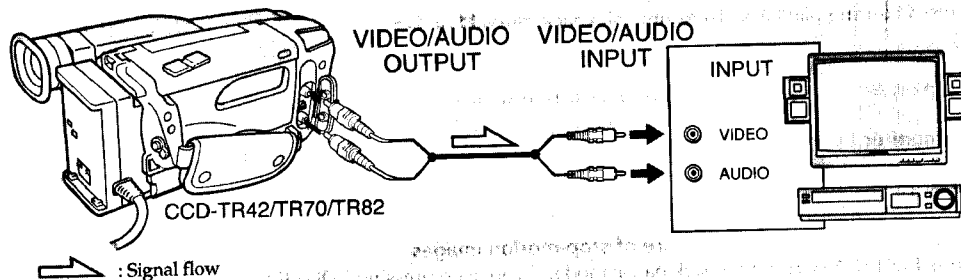

Playing Back a Tape

You can monitor the playback picture in the viewfinder. You can also monitor on the TV screen, after connecting the camcorder to the TV/VCR (p.16). You can control playback using the supplied Remote Commander (p.49).

(1) While pressing the small green button on the POWER switch, slide it to PLAYER. **(2)** Insert the recorded tape with the window facing out. **(3)** Press \triangleright . Playback starts.

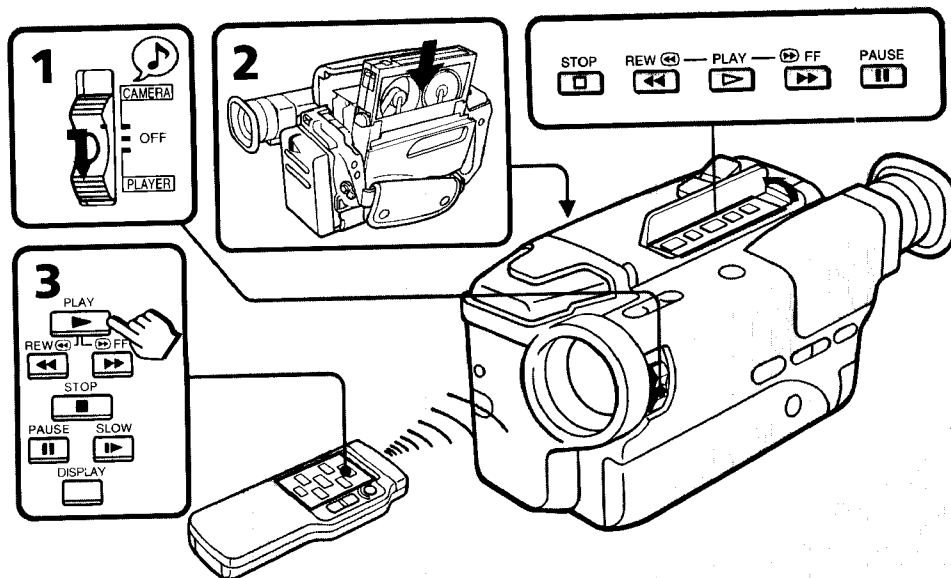

Connections for Playback/Playing Back a Tape

Playing Back a Tape

To stop playback, press □.

To rewind the tape, press ◀◀.

To advance the tape rapidly, press ▶▶.

Various Playback Modes

To view a still picture (playback pause)

Press ■■ during playback. To resume playback, press ■■ or ▷.

To locate a scene (Picture Search)

Keep pressing ◀◀ or ▶▶ during playback. To resume normal playback, release the button.

To monitor the high-speed picture during fastforward or rewind (Skip Scan)

Keep pressing ◀◀ while rewinding or ▶▶ while advancing the tape. To resume normal playback, press ▷.

To view the picture in a sequence of stop-motion images

Press EDITSEARCH in playback pause mode. If you keep pressing EDITSEARCH, you can view the picture playback in the forward (+) or reverse (-) direction.

To view the picture at 1/5 speed (Slow Playback) (only with the Remote Commander)

Press ▶▶ on the Remote Commander during playback. To resume normal playback, press ▷. If slow playback lasts for about 1 minute, it shifts to normal speed automatically.

Note on playback

- Streaks appear and the sound is muted in the various playback modes.
- When still picture mode lasts for 5 minutes or more, the camcorder automatically enters stop mode.

To display the viewfinder screen indicators on the TV

Press DISPLAY on the Remote Commander.

To erase the indicators, press DISPLAY again.

To select the monitor sound – For stereo models (CCD-TR72/TR80)

Change the "HiFi SOUND" mode setting in the menu system (p.25)

Using Alternate Power Sources

You can choose any of the following power sources for your camcorder: battery pack (P.6), house current, and 12/24 V car battery. Choose the appropriate power source depending on where you want to use your camcorder.

Place	Power source	Accessory to be used
Indoors	House current	AC power adaptor AC-V25/V25A/V25B (supplied), AC-S10, AC-V55
Outdoor	Battery pack	Battery pack NP-55 (supplied), NP-80, NP-80D, NP-77H, NP-66H, NP-60D, NP-55H
In the car	12 V or 24 V car battery	DC pack DCP-77

Using House Current

To use the supplied AC-V25/A25A/V25B AC power adaptor:

(1) Lift up the viewfinder. (2) Connect the AC power cord to a wall outlet. Connect the bottom of the AC power adaptor to the battery mounting surface of the camcorder. (3) Set the selector to VTR (DC OUT).

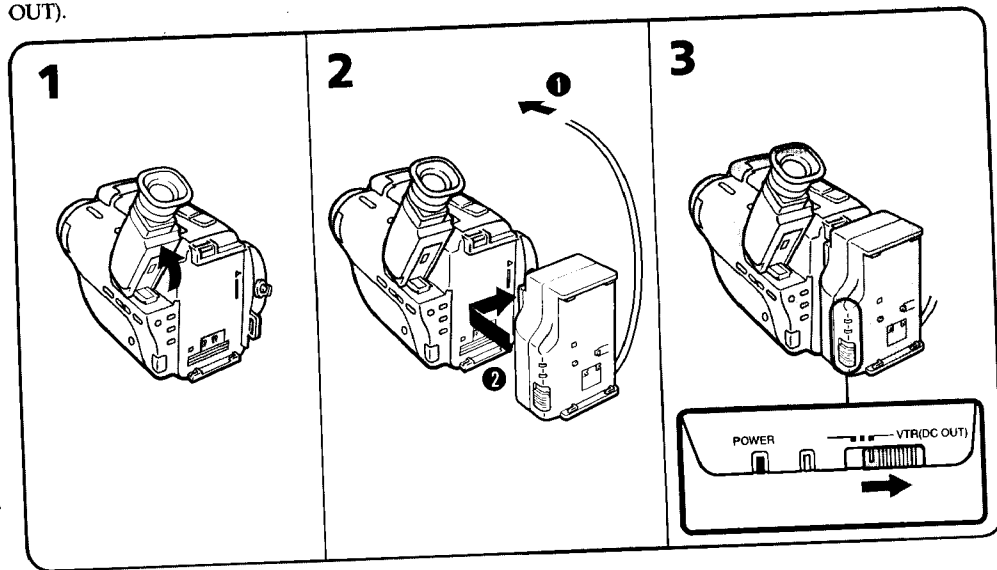

Notes on the POWER lamp

- The POWER lamp will remain lit for a while even if the unit is unplugged after use. This is normal.
- If the POWER lamp does not light, set the selector to the center position and disconnect the power cord. After about one minute, reconnect the power cord and set the selector to VTR (DC OUT) again.

To remove the adaptor

The adaptor is removed in the same way as the battery pack. (p.8)

Using Alternate Power Sources

Using a Car Battery

Use the DCP-77 DC pack (not supplied). Connect the cord of the DC pack to the cigarette lighter socket of a car (12 V or 24 V). Connect the DC pack to the battery mounting surface of the camcorder.

To remove the DC pack

The DC pack is removed in the same way as the battery pack. (p.8)

Options for Charging the Battery Pack

- AC-S10 AC power adaptor:
You can charge a battery pack whether it is used up or not with this adaptor because it has a discharging function.
- BC-S10 portable battery charger (ideal for travel):
You can charge a battery pack on 100 — 240 V AC current.

Recording with the Date or Time

Before you start recording, press DATE or TIME. You can record the date or time displayed in the viewfinder with the picture. You cannot record the date and time at the same time. Except for the date or time indicator, no indicator in the viewfinder is recorded.

The clock is set to the East Coast Standard Time at the factory.

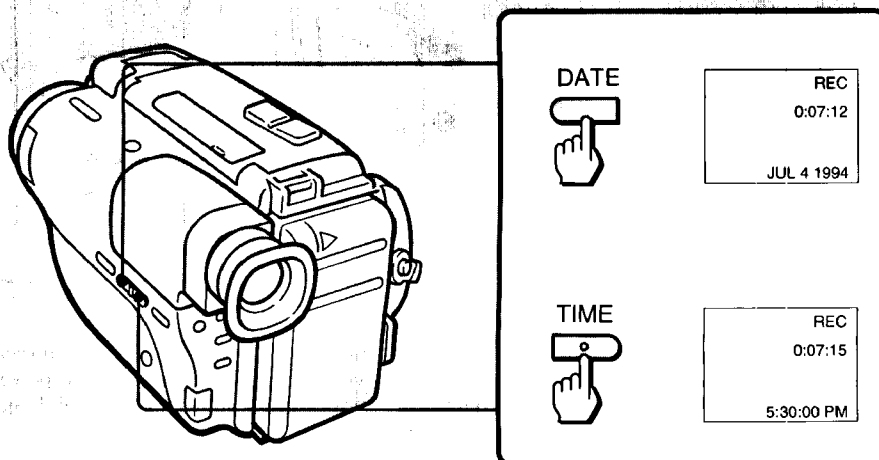

To Stop Recording with the Date or Time

Press DATE or TIME again. Recording continues.

Shooting with Backlighting

When you shoot a subject with the light source behind the subject or a subject with a light background, use the BACK LIGHT.

Press BACK LIGHT. The  indicator appears inside the viewfinder.

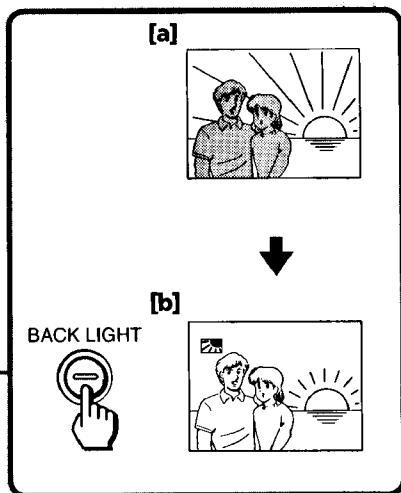
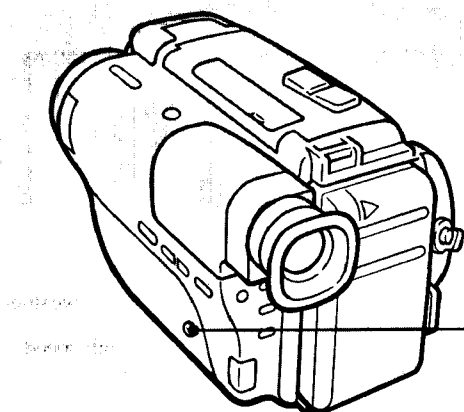

[a] Subject is too dark because of backlight.

[b] Subject becomes bright with backlight compensation.

After shooting

Press BACK LIGHT again to let the  indicator go out under normal lighting condition. Otherwise, the picture will be too bright under normal lighting condition.

This function is also effective under following conditions:

- On the snow e.g. at the ski resort
- At the beach under strong sunshine
- A subject with a light source nearby or a mirror reflecting light
- A white subject against a white background. Especially when you shoot a person wearing shiny clothes made of silk or synthetic fiber, his or her face tends to become dark if you do not use this function.

Using the PROGRAM AE Function

You can select from four PROGRAM AE (Auto Exposure) modes to suit your shooting situation. When you use PROGRAM AE, you can get a Portrait effect (the subject is in focus and the background is out of focus), capture high-speed action or night views.

Selecting the Best Mode

Select the best mode by using the following examples.



Portrait mode

- A still subject such as a person or flower
- Subject behind an obstacle such as a net
- Zooming in on a subject in telephoto



Sports mode

- Outdoor sports scenes such as football, tennis, golf or skiing
- A landscape in a moving car



High-speed shutter mode

- A golf swing or a tennis match in fine weather with the ball captured clearly
- Playing back certain scenes with high-speed movements in clear, sharp picture



Twilight mode

- Recording night views neon signs or fireworks

Using the PROGRAM AE Function

Press PROGRAM AE repeatedly so that the desired mode indicator appears inside the viewfinder.

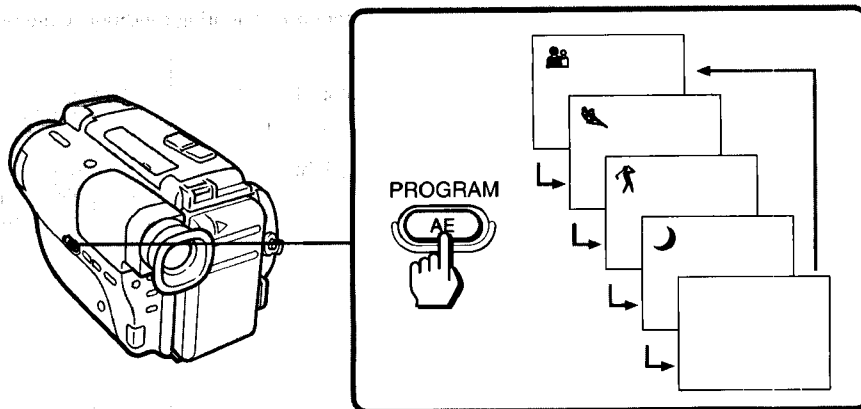

Note on shutter speed

The shutter speed in each PROGRAM AE mode is as follows:

Portrait mode – between 1/60 to 1/2000

Sports mode – between 1/60 to 1/500

High-speed shutter mode – 1/4000

Twilight mode – 1/60

Normal mode – 1/60

Fade-in and Fade-out

You can fade in or fade out to give your recording a professional appearance. When fading in, the picture will gradually appear from black or mosaic. The sound will also gradually increase. When fading out, the picture will gradually fade to black or mosaic. The sound will also decrease.

When Fading in [a]

- (1) During the camcorder is in Standby mode, press FADER. The fade indicator starts flashing.
- (2) Press START/STOP to start recording. The fade indicator stops flashing.

When Fading out [b]

- (1) During recording, press FADER. The fade indicator starts flashing.
- (2) Press START/STOP to stop recording. The fade indicator stops flashing and recording stops.

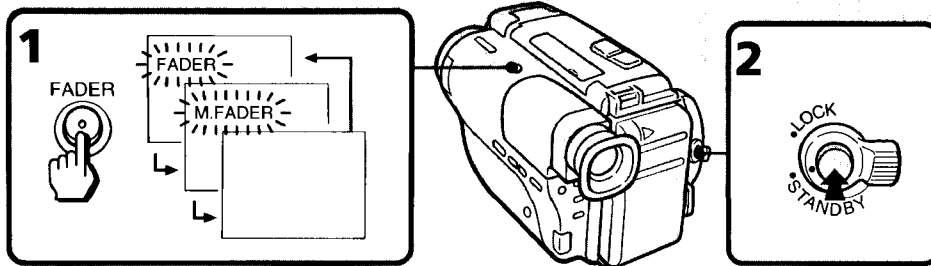
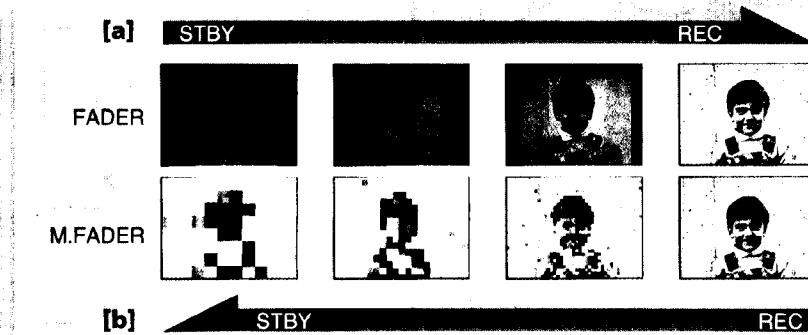

To Cancel the Fade-in/out Function

Before pressing START/STOP, press FADER once or twice until the fade indicator disappears.

When the date/time indicator is displayed

The date/time does not fade in nor fade out.

Using the PROGRAM AE Function/Fade-in and Fade-out

Releasing the Steady Shot Function

— For the model with the STEADY SHOT switch (CCD-TR82 only)

When you shoot, the  indicator appears in the viewfinder. This indicates that the Steady Shot function is working and the camcorder compensates for camera-shake.

You can release the Steady Shot function. Do not use the Steady Shot function such as when shooting stationary object with a tripod.

Set STEADY SHOT to OFF.

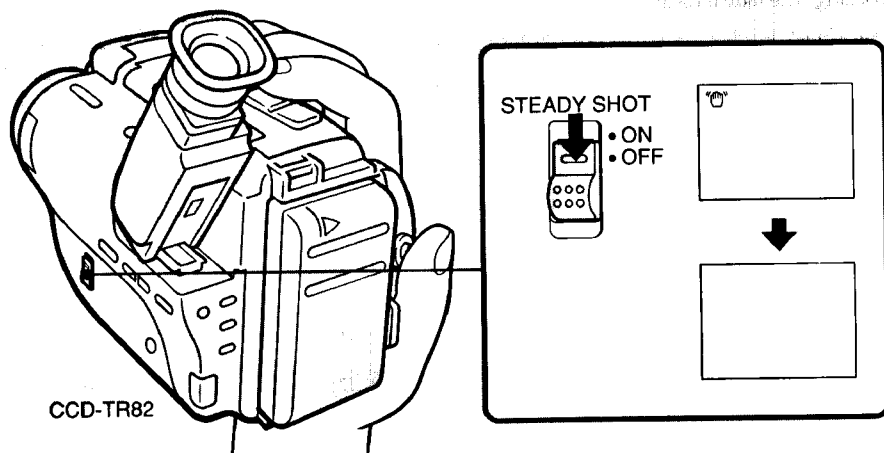

To Activate the Steady Shot Function Again

Set STEADY SHOT to ON.

Notes on the Steady Shot Function

- The Steady Shot function will not correct excessive camera-shake.
- When you switch the STEADY SHOT, the exposure may vary.

Changing the Mode Settings

You can change the mode settings in the menu system to further enjoy the features and functions.

(1) Press MENU to display the menu in the viewfinder. (2) Press \uparrow or \downarrow to select the desired item, then press EXECUTE. (3) Press \uparrow or \downarrow to set the desired mode, then press EXECUTE. If you want to change the other modes, repeat steps 2 and 3. (4) Press MENU to erase the menu display.

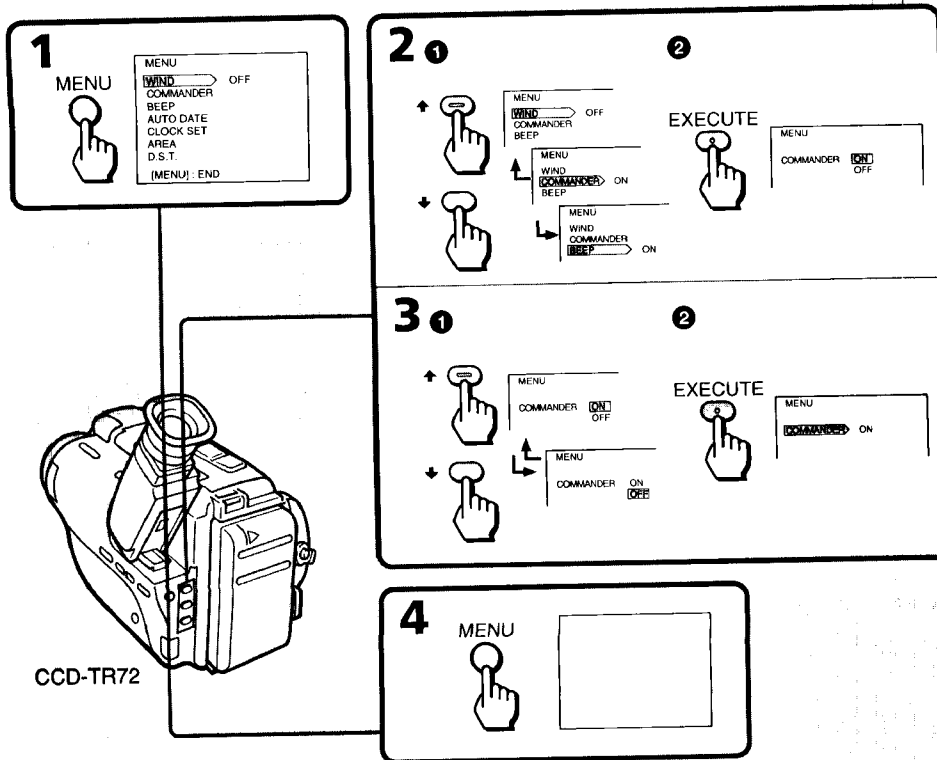

Note on BACK UP

When BACK UP indicator appears on the menu display, the settings of items are retained even when the battery is removed, as long as the lithium battery is in place.

Selecting the Mode Setting of Each Item

Common Items in CAMERA and PLAYER Modes

COMMANDER <ON/OFF>

- Select ON when using the supplied Remote Commander for the camcorder.
- Select OFF when not using the Remote Commander for the camcorder.

BEEP <ON/OFF>

- Select ON so that beeps sound when you start/stop recording.
- Select OFF when you do not want to hear the beep sound.

Changing the Mode Settings

Items in CAMERA mode

WIND <ON/OFF>

— For stereo models (CCD-TR72/TR80)

- Select ON to reduce wind noise when recording in strong wind.
- Normally select OFF.

AUTO DATE <ON/OFF>

- Select ON to record the date of recording automatically (AUTO DATE feature p.12).
- Select OFF otherwise.

CLOCK SET

Select this item when you need to reset the clock (p.31).

AREA

Select the area number of the time zone where you will use the camcorder when you use the world clock (p.27).

D.S.T. <ON/OFF>

- Select ON to set the clock to Daylight Saving Time.
- Select OFF to set to standard time.

Items in PLAYER mode

EDIT <ON/OFF>

- Select ON to minimize the picture deterioration when editing.
- Normally select OFF.

HIFI SOUND <STEREO/1/2>

—For stereo models (CCD-TR72/TR80)

- Normally select STEREO.
- Select 1 or 2 to play back a dual soundtrack tape.

Using the World Clock

Reset the clock according to the local time zone by setting AREA and D.S.T. modes in the menu system. First find the area number in the "Time zone chart" on page 28.

(1) Turn STANDBY up. (2) Press MENU to display the menu. (3) Select AREA item (p.26). Press \uparrow or \downarrow to select the area number where you will use the camcorder. Press EXECUTE. (4) Select D.S.T. item (p.26). Press \uparrow or \downarrow to select ON: for Daylight Saving Time or OFF: for standard time. Press EXECUTE.

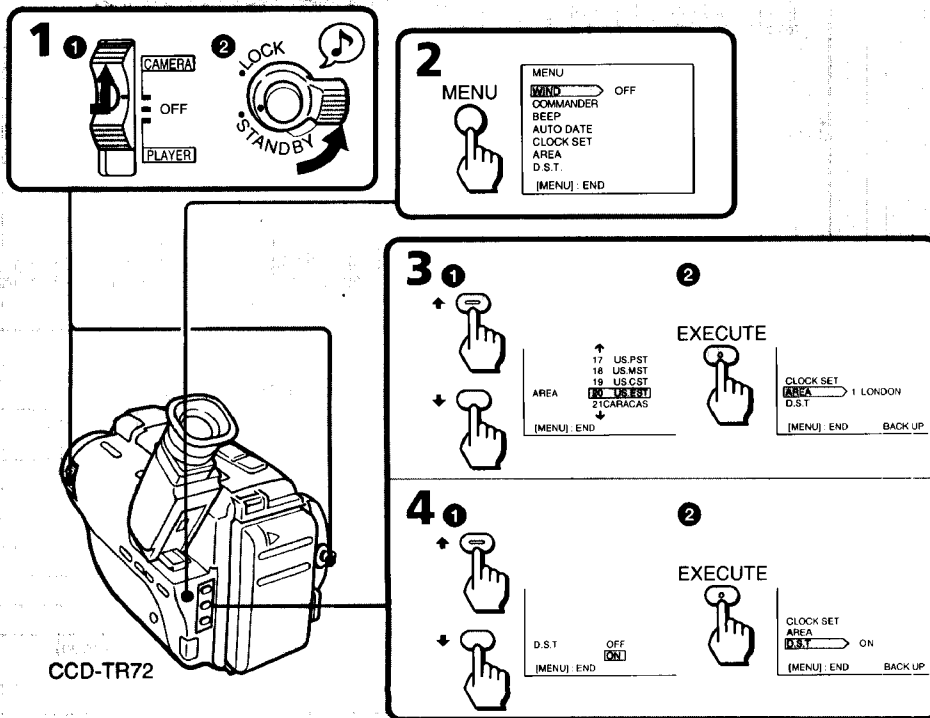

The area name appears in the viewfinder when using the world clock. The \star indicator appears in the viewfinder when setting to Daylight Saving Time.

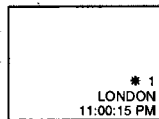

To Check the Date

Press DATE. To turn off the date indicator, press DATE again.

To restore to Your Home Area Time

Reset the AREA mode in the menu system to your home area number.

Changing the Mode Settings

Time Zone Chart

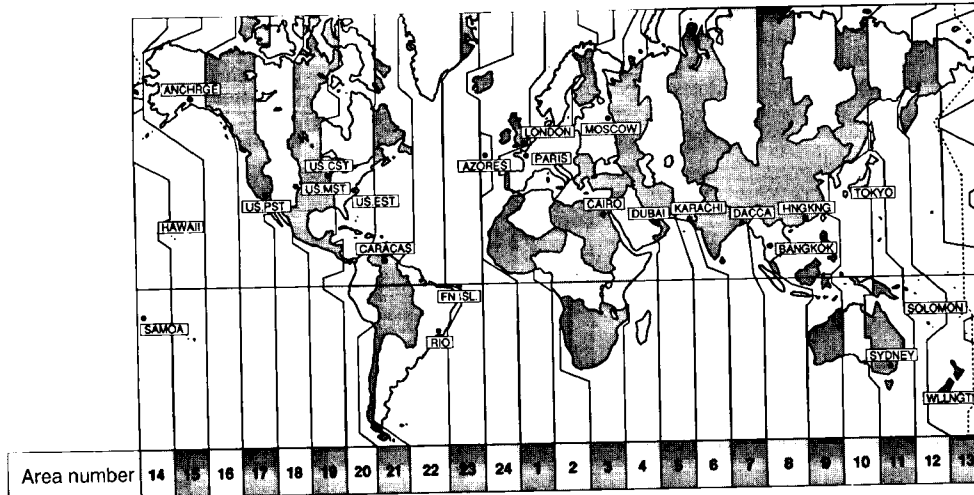

Area number	Area name	Nations or area*
1	LONDON	England, GMT (Greenwich Mean Time), Morocco, Portugal
2	PARIS	Austria, France, Germany, Italy, Netherlands, Spain, Sweden, Switzerland, CET
3	CAIRO	Egypt, Finland, Greece, Israel, Turkey
4	MOSCOW	Ethiopia, Iraq, Kenya, Saudi Arabia, former U.S.S.R. (west)
5	DUBAI	United Arab Emirates
6	KARACHI	Maldives, Pakistan
7	DACCA	Bangladesh, Myanmar
8	BANGKOK	Cambodia, Indonesia (Jakarta), Thailand, Vietnam
9	HNGKNG	Australia (west), China, Hong Kong, Indonesia (Bali, Borneo), Malaysia, Philippines, Singapore, Taiwan
10	TOKYO	Japan, Korea
11	SYDNEY	Australia (east), Guam, Saipan
12	SOLOMON	New Caledonia
13	WLLNGTN	Fiji, New Zealand
14	SAMOA	Western Samoa
15	HAWAII	HST (Hawaii Standard Time), Tahiti
16	ANCHRGE	AST (Alaska Standard Time)
17	US. PST	PST (Pacific Standard Time)
18	US. MST	MST (Mountain Standard Time)
19	US. CST	CST (Central Standard Time), Mexico
20	US. EST	EST (East Standard Time), Peru
21	CARACAS	Chili, Dominica, Venezuela
22	RIO	Argentina, Brazil, Uruguay
23	FN ISL.	Fernando de Noronha
24	AZORES	Azores Islands

* These are common names. They may be different from formal country names.

Editing onto Another Tape

You can create your own video program by editing with any other **8 mm**, **Hi8** Hi8, **VHS** VHS, **S-VHS** S-VHS, **VHS-C** VHSC, **S-VHS-C** S-VHSC, or **B** Betamax VCR that has video/audio inputs.

Before Editing

After connecting the camcorder to the VCR,
(1) Slide the POWER switch to PLAYER. **(2)** Set EDIT mode to ON in the menu system to minimise the picture deterioration (p.25).

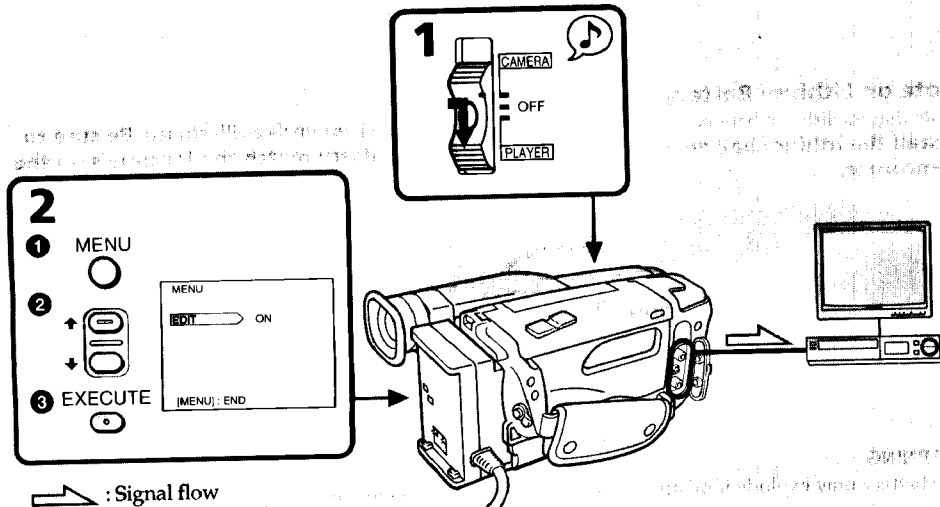

Starting Editing

(1) Insert a blank tape (or a tape you want to record over) into the recording VCR. Then insert your recorded tape into the camcorder. **(2)** Play back the recorded tape on the camcorder until you locate the point where you want to start editing. Then set the camcorder to playback pause mode. **(3)** Set the recording VCR to recording pause mode. **(4)** Press **II** on the camcorder and VCR simultaneously to start editing.

To Edit More Scenes

Repeat steps 2 to 4.

To Stop Editing

Press **□** STOP on the camcorder and VCR. When you finish editing, reset EDIT mode to OFF (p.25).

Use of the EDITSEARCH button

To play back a tape in the forward or reverse direction keep pressing EDITSEARCH during playback pause. You can play back still pictures successively at specific intervals by pressing EDITSEARCH intermittently.

Note on DISPLAY function

If you have displayed the viewfinder screen indicators on the TV (DISPLAY function), erase the indicators by pressing DISPLAY on the Remote Commander so that they will not be superimposed on the edited tape.

Changing the Mode Settings/Editing onto Another Tape

Changing the Lithium Battery In the Camcorder

Your camcorder is supplied with the lithium battery installed. The lithium battery lasts for about 1 year under normal operation. When the battery becomes weak or dead, the indicator flashes in the viewfinder for about 5 seconds when you set the POWER switch to CAMERA. In this case, **replace the battery with the Sony CR2025 or Duracell DL-2025 lithium battery. Use of another battery may present a risk of fire or explosion.**

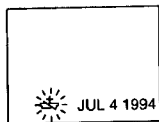

Note on Lithium Battery

Note that the lithium battery has a positive (+) and a negative (-) terminals as illustrated. **Be sure to install the lithium battery so that terminals on the battery match the terminals on the camcorder.**

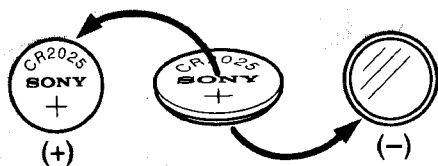

WARNING

The battery may explode if mistreated. Do not recharge, disassemble, or dispose of in fire.

Caution

Keep the lithium battery out of the reach of children. Should the battery be swallowed, consult a doctor immediately.

Changing the Lithium Battery

When replacing the lithium battery, keep the battery pack or other power source attached. Otherwise, you will need to reset the date, time and the other items with BACK UP indicator in the menu system.

(1) Open the lid of the lithium battery compartment. **(2)** Push the battery down once and pull it out from the holder. **(3)** Install the lithium battery with the positive (+) side facing out. Close the lid of the battery compartment.

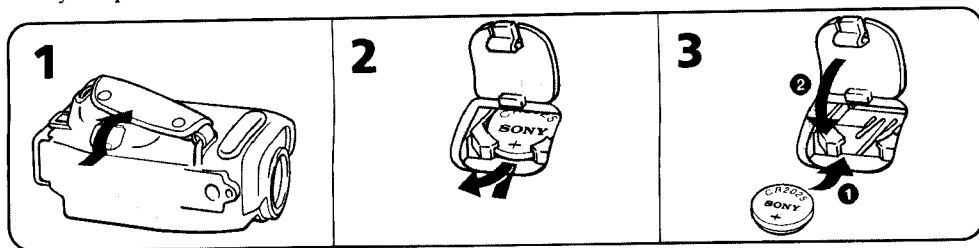

Resetting the Date and Time

Reset the date and time in the menu system.

- (1)** Press MENU to display the menu. **(2)** Press \uparrow or \downarrow to select CLOCK SET item (p.26). Press EXECUTE. **(3)** Press \uparrow or \downarrow to select the area number where you will use the camcorder. Press EXECUTE. **(4)** Select D.S.T. ON for Daylight Saving Time or OFF for standard time. Press EXECUTE. **(5)** Set year, month, day, time, minute by pressing \uparrow , \downarrow and EXECUTE. Note that when you keep \uparrow and \downarrow pressed, the digits advance faster. **(6)** Press MENU to erase the menu display.

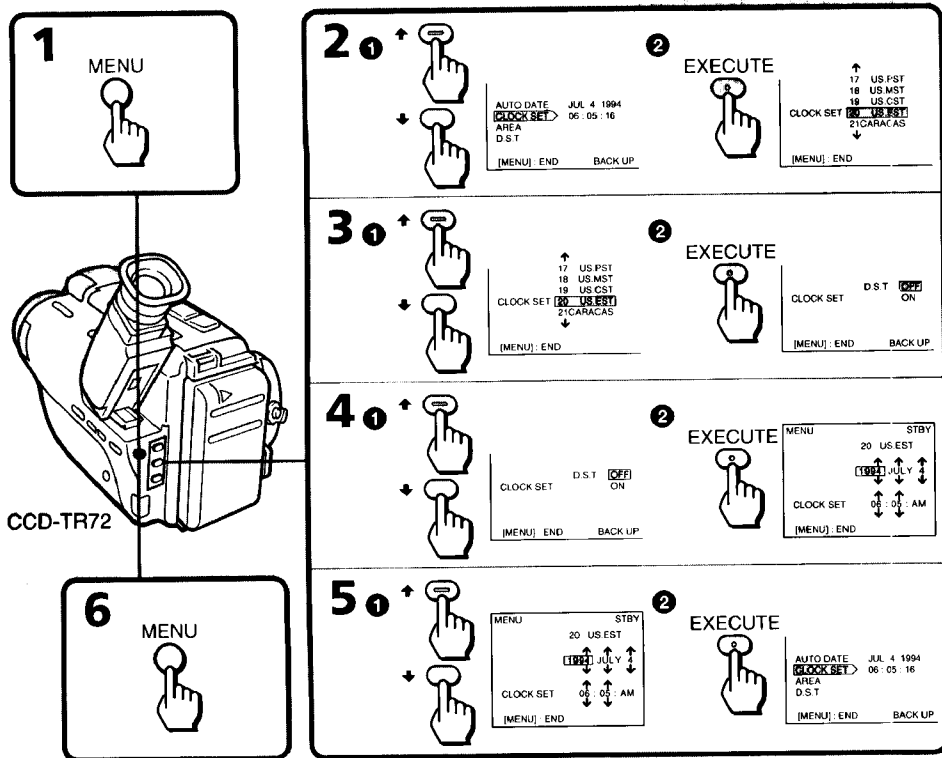

Changing the Lithium Battery in the Camcorder / Resetting the Date and Time

Time Zones and Area Numbers and Names

"S.T." in the following table stands for Standard Time.

Time Zones	Area Name	Area Number
Hawaii S.T.	HAWAI	15
Alaska S.T.	ANCHRGE	16
Pacific S.T./West Canada	US.PST	17
Mountain S.T.	US.MST	18
Central S.T.	US.CST	19
Eastern S.T./East Canada	US.EST	20

Resetting the Date and Time

To Correct the Date and Time Setting

Repeat steps 2 to 5.

To Check the Date and Time

Press DATE to display the date indicator in the viewfinder. Press TIME to display the time indicator. When you press the same button again, the indicator goes out.

To Reset to Standard Time

Change D.S.T. mode setting in the menu system (p.25).

The year indicator changes as follows:

1994 ↔ 1995 ←-----→ 2024
↑
└──────────────────┘

Note on the time indicator

The internal clock of the camcorder operates on a 12-hour cycle. 12:00:00 AM stands for midnight. 12:00:00 PM stands for noon.

Playback Modes

The playback mode is selected automatically according to the recording system (SP/LP mode) in which the tape was recorded.

Notes on AFM Hi-Fi stereo — For stereo models (CCD-TR72/TR80)

When you play back the tape, the sound is in monaural if:

- You record the tape using this camcorder, then play it back on an AFM Hi-Fi monaural video recorder/player.
- You record the tape on an AFM Hi-Fi monaural video recorder, then play it back on this camcorder.

LP (long play) mode

When you play back a tape recorded in LP mode, the LP indicator lights up in the viewfinder. This camcorder cannot record tape in LP mode.

Foreign 8 mm video

You cannot play software recorded on a different TV color system. Because the TV color systems differ from country to country, you may not be able to play back foreign pre-recorded software. Refer to page 39 to check the TV color system of foreign countries.

Tips for Using the Battery Pack

This section shows you how you can get the most out of your battery pack.

Preparing the Battery Pack

Always Carry Additional Batteries

Have sufficient battery pack power to do 2 to 3 times as much recording as you have planned.

Battery Life is Shorter in Cold Environment

Battery efficiency is decreased and the battery will be used up more quickly if you are recording in cold environment.

To Save Battery Power

Turn the STANDBY switch on the camcorder down when not recording to save battery power. [a]

A smooth transition between scenes can be made even if recording is stopped and started again. While positioning the subject, selecting an angle, or looking through the viewfinder lens, the lens moves automatically and the battery is used. The battery is also used when a tape is inserted or removed.

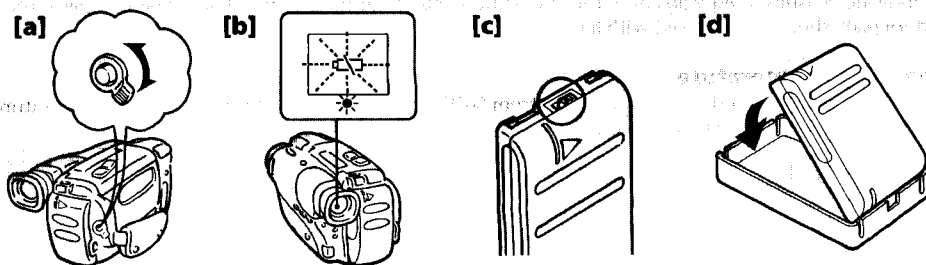

Tips for Using the Battery Pack

When to Replace the Battery Pack

While you are using your camcorder, the remaining battery indicator decreases gradually as battery power is used up.



When the remaining battery indicator reaches the lowest point, the **i** indicator appears and starts flashing in the viewfinder. **[b]** on page 33.

When the  indicator in the viewfinder changes from slow flashing to rapid flashing while you are recording, slide the POWER switch to OFF on the camcorder and replace the battery pack. Leave the tape in the camcorder to obtain smooth transition between scenes after the battery pack is replaced.

Note on the remaining battery indicator

The remaining battery indicator of the camcorder may indicate a different remaining capacity from that of the battery pack with the remaining battery indicator (not supplied). The indicator of the battery pack is more accurate.

Notes on the Rechargeable Battery Pack

The Battery Heats Up

During charging or recording, the battery pack heats up. This is caused by energy that has been generated and a chemical change that has occurred inside the battery pack. This is not cause for concern.

Battery Care

- Remove the battery pack from the camcorder after using the battery pack, and keep it in a cool place. When the battery pack is attached to the camcorder, a small amount of current flows to the camcorder even if the POWER switch is set to OFF, which shortens battery life.
- The battery pack is always discharging even when it is not in use after charging. Therefore, you should charge the battery right before using the camcorder.

How to Use the Switch on the Battery Pack

This switch is provided so that you can mark the charged battery. Set the switch to the "no mark" position when charging is completed. Set the switch to the "red mark" position when the battery is used up (or in whichever direction you want to remind yourself). **[c]** on page 33.

The Life of the Battery Pack

The battery pack can be fully charged and discharged about 500 times under normal temperatures. If the  indicator flashes rapidly just after turning on the camcorder with a fully charged battery pack, the battery pack should be replaced with a new fully charged one.

Charging Temperature

You should charge batteries at temperatures from 50°F to 86°F (from 10°C to 30°C). Lower temperatures require a longer charging time.

Notes on Charging

A Brand-new Battery

A brand-new battery pack is not charged. Before using the battery pack, charge it completely.

Before Recharging a Used Battery Pack

- Make sure to use up the battery before recharging.
- If recording is completed before the  indicator appears in the viewfinder, you should remove the tape, slide the POWER switch to CAMERA, turn STANDBY up, and leave the camcorder until the battery indicator flashes rapidly.
- When you use the AC-S10 power adaptor, you can use the discharging function.
- **Charging the usable battery causes a lowering of battery capacity. Battery capacity can be recovered if you fully discharge and charge the battery again.**

After Long Storage

Recharge the battery pack after a long period of storage. If the battery pack is charged fully but not used for a long time (about 1 year), it becomes discharged. Charge it again, but in this case the battery life will be shorter than normal. After several charging and discharging cycles, the battery life will recover its original capacity.

Notes on the Terminals

If the terminals (metal parts on the back) are not clean, the battery duration will be shortened. When the terminals are not clean or when the battery pack has not been used for a long time, repeat installing and removing the battery pack. This improves the contact condition. Also, wipe the + and - terminals with a soft cloth or paper.

Be Sure to Observe the Following



- **To prevent an accident caused by a short circuit, do not allow metal objects such as a necklace to touch the battery terminals. Carry the battery pack attaching to the terminal cover. [d] on page 33.**
- Keep the battery pack away from fire.
- Keep the battery pack dry.
- Do not open nor convert the battery pack.
- Do not expose the battery pack to any mechanical shock.

Maintenance Information and Precautions

Moisture Condensation

If the camcorder is brought directly from a cold place to a warm place, moisture may condense inside the camcorder, on the surface of the tape, or on the lens. If this happens, the tape may stick to the head drum and be damaged or the camcorder may not operate correctly. To prevent possible damage under these circumstances, the camcorder is furnished with moisture sensors. However, take the following precautions.

Inside the Camcorder

When  and  indicators flash in the viewfinder, moisture has condensed inside the camcorder. If this happens, none of the functions except cassette ejection will work.

Eject the cassette turn off the camcorder, and leave it with the cassette compartment open for about 1 hour.

If the  indicator does not light up when you turn on the power, you can use the camcorder again.

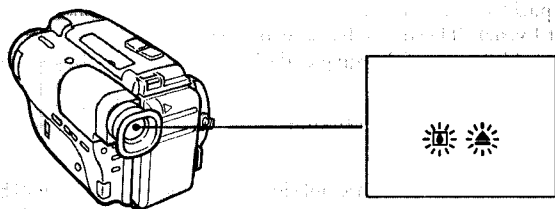

On the Surface of the Tape

If there is moisture on the surface of the tape, when you insert cassette and press a tape transport button (▶ PLAY, etc.), the  indicator flashes in the viewfinder. If this happens, none of the functions except cassette ejection will work.

Eject the cassette and leave it for about 1 hour.

If the  indicator does not light up when you insert the cassette and press a tape transport button, you can use the camcorder again.

On the Lens

No indicator will appear, but the picture becomes dim. Turn off the power and do not use the camcorder for about 1 hour.

How to Prevent Moisture Condensation

When bringing the camcorder from a cold place to a warm place, put the camcorder in a plastic bag and allow it to adapt to room conditions over a period of time.

- (1) Be sure to tightly seal the plastic bag containing the camcorder.
- (2) Remove the bag when the air temperature inside it has reached the temperature surrounding it (after about one hour).

Video Head Cleaning

To ensure clear pictures, clean the video heads periodically. When playback pictures are "noisy" or hardly visible, the video heads may be contaminated.



[a] Slight contamination

[b] Critical contamination

If this happens, clean the video heads with the Sony V8-25CLH cleaning cassette (not supplied). After checking the picture, if it is still "noisy", repeat the cleaning. (Do not repeat cleaning more than 5 times.)

Caution

Do not use a commercially available wet-type cleaning cassette. It may damage the video heads.

Note

If the V8-25CLH cleaning cassette is not available in your area, consult your nearest Sony dealer.

Removing Dust from inside the Viewfinder

(1) While sliding the viewfinder release knob to the left, flip open the viewfinder. **(2)** Clean the surface with a commercially available blower.

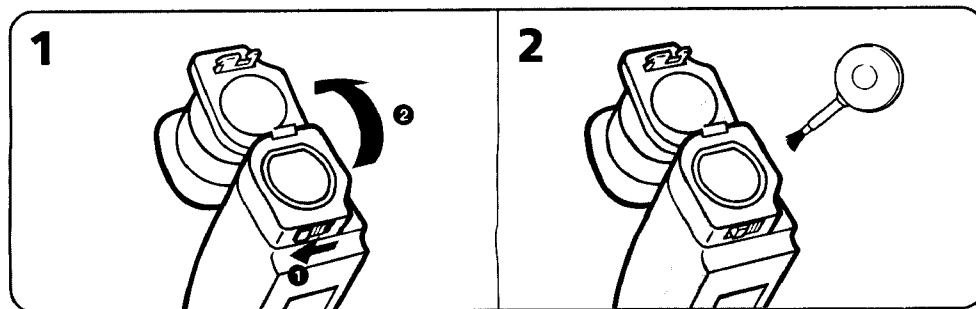

Precautions

Camcorder Operation

- Operate the camcorder using 6.0 V (battery pack), or 7.5 V (AC power adaptor).
- For DC or AC operation, use only the accessories recommended in this manual.
- Should any solid object or liquid fall into the casing, unplug the camcorder and have it checked by your nearest Sony dealer before operating it any further.
- Avoid rough handling or mechanical shock. Be particularly careful of the lens.
- Keep the POWER switch set to OFF when not using the camera.
- Do not wrap up the camcorder and operate it since heat may build up internally.
- Keep the camcorder away from strong magnetic fields or mechanical vibration.

On Handling Tapes

Do not insert anything into the small holes on the rear of the cassette. These holes are used to sense the type, thickness of tape, or if the tab is out or in.

Camcorder Care

- When the camcorder is not to be used for a long time, disconnect the power source and remove the tape. Periodically turn on the power, operate the camera and player sections and play back a tape for about 3 minutes.
- Clean the lens with a soft brush to remove dust. If there are fingerprints on the lens, remove them with a soft cloth.
- Clean the camcorder body with a soft dry cloth, or a soft cloth lightly moistened with a mild detergent solution. Do not use any type of solvent which may damage the finish.

AC Power Adaptor

Charging

- Use only for the specified battery pack. This unit cannot be used to charge an NP-500 series battery pack.
- Attach the battery pack firmly.
- Charge the battery pack on a flat surface without vibration.

Others

- The model for USA or Canada: One blade of the plug is wider than the other for the purpose of safety and will fit into the power outlet only one way. If you are unable to insert the plug fully into the outlet, contact your dealer.
- Unplug the unit from the wall (mains) outlet when not in use for a long time. To disconnect the cord (mains lead), pull it out by the plug. Never pull the cord itself.
- Do not operate the unit with a damaged cord or if the unit has been dropped or damaged.
- Do not bend the AC power cord forcibly, or put a heavy object on it. This will damage the cord and may cause a fire or an electrical shock.
- Be sure that nothing metallic comes into contact with the metal parts of the connecting plate. If this happens, a short may occur and the unit may be damaged.
- Always keep the metal contacts clean.
- Do not disassemble the unit.
- Do not apply mechanical shock or drop the unit.
- While the unit is in use, particularly during charging, keep it away from AM receivers and video equipment because it will disturb AM reception and video operation.
- The unit becomes warm while in use. This is normal.
- Do not place the unit in locations that are:
 - Extremely hot or cold
 - Dusty or dirty
 - Very humid
 - Vibrating

If any difficulty should arise, unplug the unit and contact your nearest Sony dealer.

Using Your Camcorder Abroad

Each country has its own electricity and TV color systems. Before using your camcorder abroad, check the following points:

Power Sources

You can use your camcorder in any country with the supplied AC power adaptor within 100 V to 240 V AC, 50/60 Hz. Use a commercially available AC plug adaptor [a], if necessary, depending on the design of the wall outlet [b].

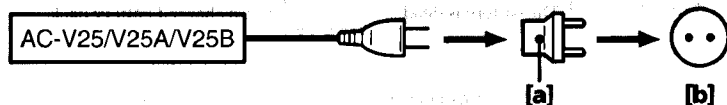

Difference In Color Systems

This camcorder is an NTSC system-based camcorder. If you want to view the playback picture on a TV, it must be an NTSC system based TV. When you want to use a PAL-M system based TV, you will need a NTSC/PAL-M transcoder. Check the following alphabetical list.

NTSC system countries

Bahama Islands, Bolivia, Canada, Central America, Chile, Colombia, Ecuador, Jamaica, Japan, Korea, Mexico, Peru, Surinam, Taiwan, the Philippines, the U.S.A., Venezuela, etc.

PAL system countries

Australia, Austria, Belgium, China, Denmark, Finland, former West Germany, Great Britain, Holland, Hong Kong, Italy, Kuwait, Malaysia, New Zealand, Norway, Portugal, Singapore, Spain, Sweden, Switzerland, Thailand, etc.

PAL M system country

Brazil

PAL N system countries

Argentina, Paraguay, Uruguay

SECAM system countries

Bulgaria, France, Guyana, Hungary, Iran, Iraq, Monaco, Poland, former Soviet Union, etc.

Trouble Check

If you run into any problem using the camcorder, use the following table to troubleshoot the problem. Should the difficulty persist, disconnect the power source and contact your Sony dealer or local authorized Sony service facility.

Camcorder

	Symptom	Cause	Corrective Actions	page
Power	The power is not on.	The battery pack is not attached.	Attach the battery pack.	8
		The battery is dead.	Use a charged battery pack.	6
		The AC power adaptor is not connected to a wall outlet.	Connect the AC power adaptor to a wall outlet.	19
	The power goes off.	While being operated in CAMERA mode, the camcorder has been in the Standby mode for more than 5 minutes.	Turn STANDBY down once and turn it up again.	12
		The battery is dead.	Use a charged battery pack.	6
	The battery pack is quickly discharged.	The ambient temperature is too low.	—	33
		The battery pack has not been charged fully.	Charge the battery pack again.	6
		The battery pack is completely dead, and cannot be recharged.	Use another battery pack.	34
	Operation	START/STOP does not operate.	The tape is stuck to the drum.	Eject the tape.
The tape has run out.			Rewind the tape or use a new one.	17
The POWER switch is set to PLAYER.			Set it to CAMERA.	11
The tab on the cassette is out (red).			Use a new tape or slide the tab.	9
The cassette cannot be removed from the holder.		The battery is dead.	Use a charged battery pack or the AC power adaptor.	6, 19
No function except for cassette ejection works.		Moisture condensation has occurred.	Remove the cassette and leave the camcorder for at least an hour.	36
The tape does not move when a tape transport button is pressed.		The POWER switch is set to CAMERA or OFF.	Set it to PLAYER.	17
		The tape has run out.	Rewind the tape or use a new one.	18
The date or time indicator is flashing.		You pressed DATE and TIME together for more than 2 seconds.	The camcorder is not malfunctioning. You may start recording. Flashing will stop soon.	—
The STEADY SHOT function does not activate. (CCD-TR82)		STEADY SHOT is set to OFF.	Set STEADY SHOT to ON.	24

	Symptom	Cause	Corrective Actions	page
Picture/Sound	No sound or only a low sound is heard when playing back a tape. (CCD-TR72/80)	The stereo tape is played back with HiFi SOUND set to "1" or "2" in the menu system.	Set to "STEREO" in the menu system.	25
	Excessive high-pitched sound is heard. (CCD-TR72/TR80)	The picture has been recorded with WIND set to ON in the menu system.	When there is no wind, set it to OFF.	25
	The image on the viewfinder screen is not clear.	The viewfinder lens is not adjusted.	Adjust the viewfinder lens.	10
	A vertical band appears when a subject such as lights or a candle flame is shot against a dark background.	The contrast between the subject and background is too high.	The camcorder is not malfunctioning. Change locations.	—
	The menu is not displayed on the TV.	DISPLAY on the Remote Commander has not been pressed.	Press DISPLAY on the Remote Commander.	18
	The playback picture is not clear.	EDIT is set to ON in the menu system.	Set it to OFF.	25
	The picture is "noisy".	The video heads may be dirty.	Clean the heads using the Sony V8-25CLH cleaning cassette.	37
Others	The supplied Remote Commander does not work.	COMMANDER is set to OFF in the menu system.	Set it to ON.	25
		Something is blocking the infrared rays.	Remove the obstacle.	—
		The battery is not inserted with the correct polarity.	Insert the battery with the correct polarity.	48
		The batteries are dead.	Insert new ones.	48
	There is dust in the viewfinder.	—	Flip open the viewfinder and clean the viewfinder lens.	37

Trouble Check

Trouble Check

AC Power Adaptor

	Symptom	Cause	Corrective Actions	page
AC power adaptor	The POWER lamp does not light.	—	Set the selector to the center position and disconnect the power cord. After about one minute, reconnect the power cord and set the selector to CHARGE again.	7
	The CHARGE lamp flashes.		See the following chart.	

When the CHARGE Lamp Flashes

Check through the following chart.

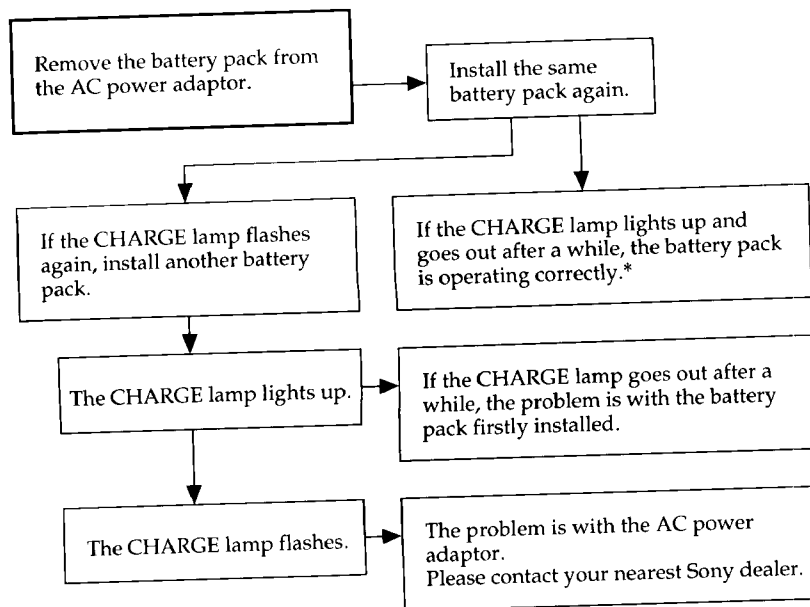

* If you use a battery pack which you have just bought or which has been left unused for a long time, the CHARGE lamp may flash at the first charging. But this is not a problem. Repeat again to charge with the same battery pack.

Specifications

Video Camera Recorder System

Video recording system: Two rotary heads, Helical scanning, FM system

Audio recording system: Rotary heads, FM system

Video signal: NTSC color, EIA standards

Usable cassette: 8 mm video format cassette (standard 8 mm)

Tape speed: <SP mode> Approx. 19/32 inches (1.43 cm)/second, <LP mode> Approx. 5/16 inches (0.72 cm)/second (playback only)

Recording time: SP mode 2 hours (P6-120)

Playback time: <SP mode> 2 hours (P6-120), <LP mode> 4 hours (P6-120)

Fastforward/rewind time: Approx. 6 min. 30 sec. (P6-120)

Image device: CCD (Charge Coupled Device)

Viewfinder: See the table below.

Lens: See the table below.

Color temperature: Auto
Minimum illumination: See the table below.

Illumination range: See the table below.

Recommended illumination: More than 100 lx

Output connector

Video output: Phono jack, 1 Vp-p, 75 Ω , unbalanced, sync negative

Audio output: See the table below.

RFU DC OUT: Special minijack, DC 5 V

Headphones/Earphone jack: See the table on the next page.

LANC jack: Stereo mini-minijack (\varnothing 2.5 mm)

MIC jack: See the table on the next page.

General

Power requirements: On battery mounting surface 6.0 V (battery pack), 7.5 V (AC power adaptor)

Average power consumption: See the table on the next page.

Installation: Vertically, Horizontally

Operating temperature: 32°F to 104°F (0°C to 40°C)

Storage temperature: -4°F to +140°F (-20°C to +60°C)

Dimensions: See the table on the next page.

Mass: See the table on the next page.

Microphone: See the table on the next page.

Supplied accessories: See page 5.

Model	CCD-TR42	CCD-TR70	CCD-TR72	CCD-TR80	CCD-TR82	Notes
Viewfinder	B/W	Color	B/W	Color	B/W	Electronic viewfinder
Lens	12 x	10 x	12 x			Combined power zoom lens, Filter diameter 1 1/2 inches (37 mm), TTL autofocus system inner focus wide macro system
Focal distance f =	7/32 - 2 5/8 in (5.4 - 64.8 mm)	7/32 - 2 1/4 in (5.4 - 54 mm)	7/32 - 2 5/8 in (5.4 - 64.8 mm)			—
	—				9/32 - 3 1/8 in (6.5 - 78 mm)	at Steady Shot
	1 9/16 - 18 1/2 in (39 - 468 mm)	1 9/16 - 15 3/8 in (39 - 390 mm)	1 9/16 - 18 1/2 in (39 - 468 mm)		1 7/8 - 22 1/4 in (47 - 564 mm)	When converted into a 35-mm still camera
Minimum illuminations	2 lx			5 lx	F 1.8	
Illumination range	2 - 100,000 lx			5 - 100,000 lx	—	
Audio output	Monaural		2: stereo L and R		Monaural	Phono jack 7.5 dBs, (at output impedance 47 k Ω) impedance less than 2.2 k Ω

Trouble Check/Specifications

Specifications

Model	CCD-TR42	CCD-TR70	CCD-TR72	CCD-TR80	CCD-TR82	Notes
Headphones/ Earphone jack	Minijack		Stereo minijack		Minijack	—
MIC jack	Minijack		Stereo minijack		Minijack	-66 dBs low impedance with 2.5 to 3 V DC, output impedance 6.8 k Ω (\varnothing 3.5 mm)
Average power consumption	4.9 W	5.2 W	5.0 W	5.3 W	5.4 W	Camera recording, including the viewfinder
Dimensions	4 1/2 x 4 3/8 x 8 1/4 inches (114 x 110 x 207 mm)		4 1/2 x 4 3/8 x 8 1/4 inches (114 x 110 x 208 mm)		4 1/2 x 4 3/8 x 8 1/4 inches (114 x 110 x 207 mm)	w/h/d
Mass	1 lb 15 oz (890 g)	1 lb 15 oz (880 g)	1 lb 15 oz (890 g)	1 lb 15 oz (880 g)	1 lb 15 oz (900 g)	Excluding the battery pack, lithium battery, cassette, and shoulder strap
Mass	2 lb 7 oz (1,110 g)				2 lb 8 oz (1,120 g)	Including the battery pack NP-55, lithium battery CR2025, cassette P6-120, and shoulder strap
Microphone	Monaural		Stereo		Monaural	Electret condenser microphone

AC power adaptor

Power requirements: 110 - 240 V AC*, 50/60 Hz

Power consumption: See the table below.

Output voltage: See the table below.

Application: Sony battery packs NP-55, NP-55H, NP-60D, NP-66H, NP-77H, NP-80/80D

Operating temperature: 32°F to 104°F (0°C to 40°C)

Storage temperature: -4°F to +140°F (-20°C to +60°C)

Dimensions: Approx. 4 1/8 x 1 15/16 x 2 1/2 inches (103 x 49 x 63 mm) including projecting parts and controls

Mass: See the table below.

* Canadian Standard Association (CSA) certifies 120 V AC only.

Model	AC-V25	AC-V25A	AC-V25B	Notes
Power consumption	15 W	17 W	17 W	—
Output voltage	7.5 V, 1.2 A	7.5 V, 1.5 A	7.5 V, 1.5 A	DC OUT in operating mode
Mass	10 oz (290 g)	11 oz (320 g)	10 oz (290 g)	—

Design and specifications are subject to change without notice.

Identifying the Parts

The illustrations in this section are of CCD-TR82.

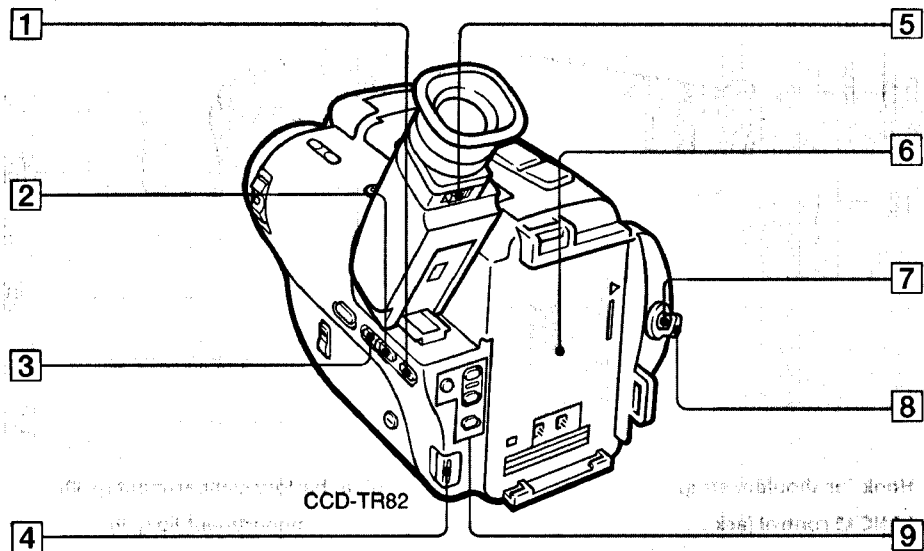

1 COUNTER RESET button (p.12)

2 TIME button (p.20)

3 DATE button (p.20)

4 BATT (battery) release knob (p.8)

5 Viewfinder release knob (p.14, 37)

6 Battery mounting surface (p.8)

7 START/STOP button (p.11)

8 STANDBY switch (p.10, 11)

9 Menu operation buttons (p.25, 31)

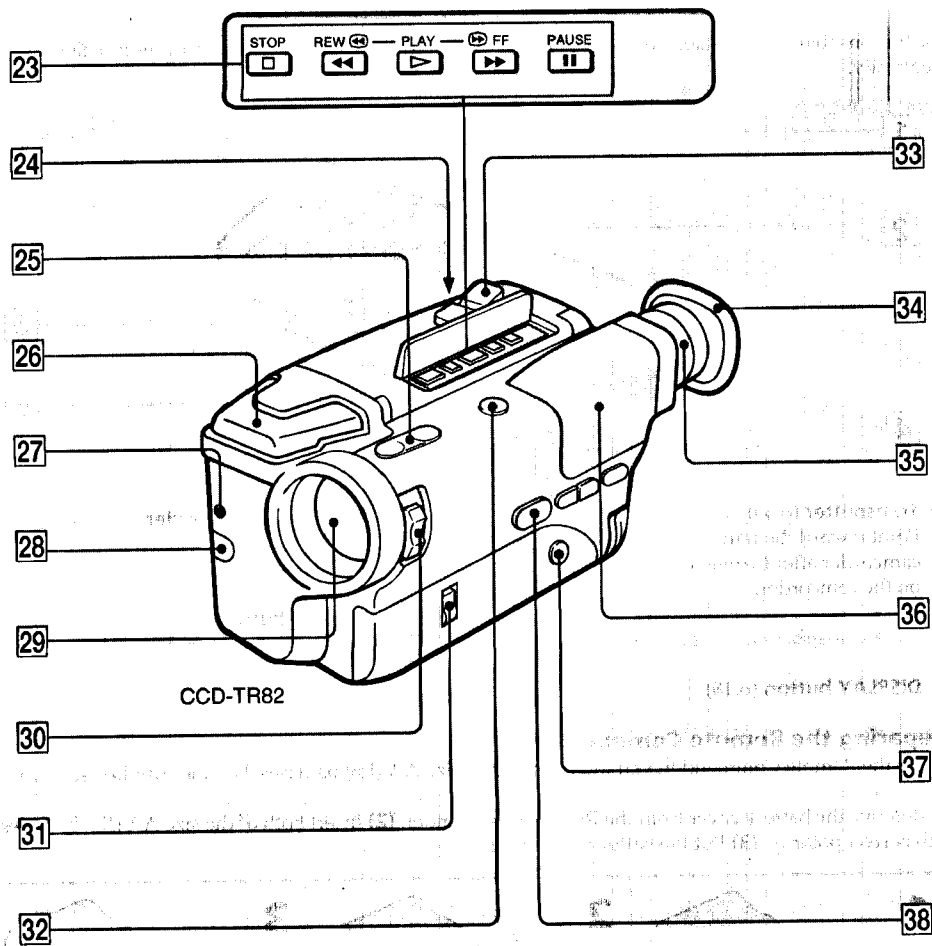

23 Tape transport buttons (p.17)

- STOP
- ◀◀ REW (rewind)
- ▶ PLAY (playback)
- ▶▶ FF (fast forward)
- || PAUSE

These buttons will function in PLAYER mode.

24 EJECT button (p.9)

25 EDITSEARCH button (p.15)

26 Built-in microphone

27 Camera recording/battery lamp

28 Remote sensor (p.49)

29 Lens cover

30 POWER switch (p.10, 11)

31 STEADY SHOT switch (p.24)

32 FADER button (p.23)

33 POWER ZOOM button (p.13)

34 Eyecup (p.14)

35 Viewfinder adjustment ring (p.10)

36 Viewfinder (p.10, 14)

37 BACK LIGHT button (p.21)

38 PROGRAM AE button (p.22)

Identifying the Parts

Remote Commander

The buttons that have the same name on the Remote Commander and on the camcorder function identically.

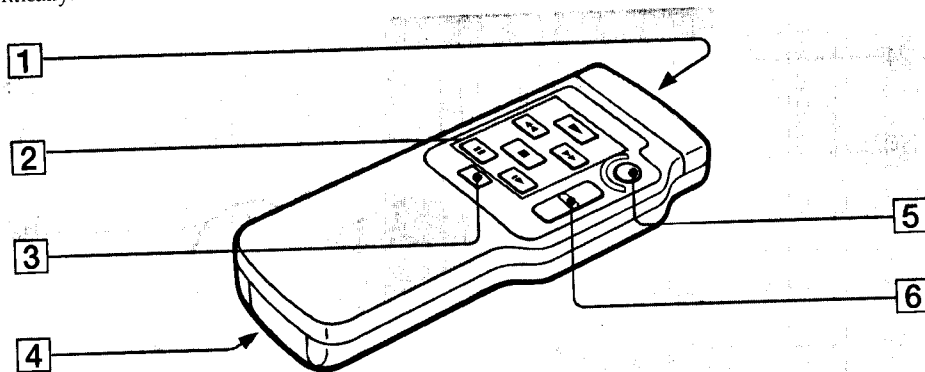

1 Transmitter (p.49)

Point toward the remote sensor to control the camcorder after turning on the POWER switch on the camcorder.

2 Tape transport buttons (p.17)

3 DISPLAY button (p.18)

4 Size AA (R6) battery holder

5 START/STOP button

6 Power zoom button

The zooming speed is unchangeable on the Remote Commander.

Preparing the Remote Commander

To use the Remote Commander, you must insert two size AA (R6) batteries. Use the supplied size AA (R6) batteries.

(1) Remove the battery cover from the Remote Commander. **(2)** Insert both of the size AA (R6) batteries with correct polarity. **(3)** Put the battery cover back onto the Remote Commander.

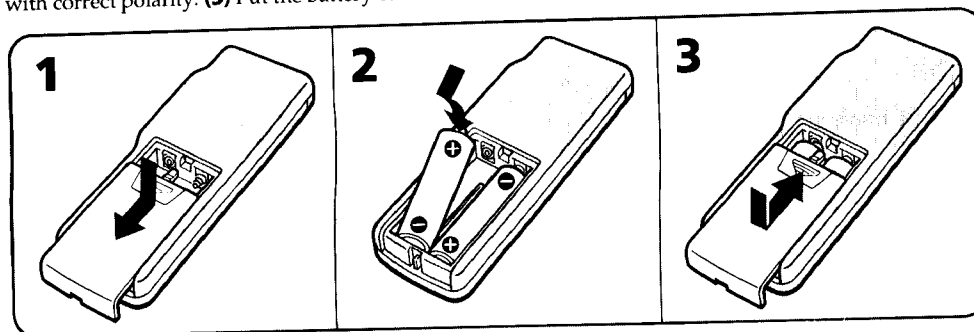

Note on battery life

The batteries for the Remote Commander last about 6 months under normal operation. When the batteries become weak or dead, the Remote Commander does not work.

To avoid damage from possible battery leakage

Remove the batteries when you will not use the Remote Commander for a long time.

Using the Remote Commander

Make sure that the COMMANDER mode is set to ON in the menu system (p.25).

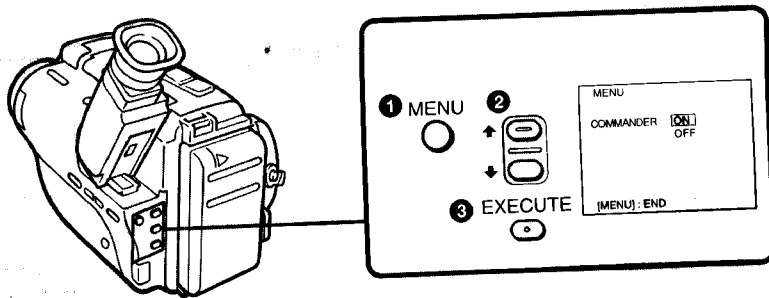

Remote Control Direction

Aim the Remote Commander to the remote sensor within the range as shown below.

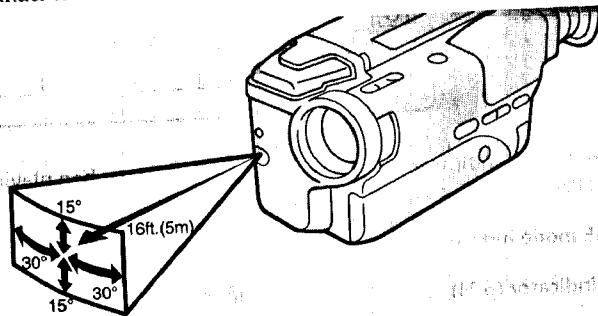

Notes on the Remote Commander

- Keep the remote sensor away from strong light sources such as direct sunlight or illumination. Otherwise, the remote control may not be effective.
- Be sure that there is no obstacle between the remote sensor and the Remote Commander.
- This camcorder works at commander mode VTR 2. The commander modes (1, 2, and 3) are used to distinguish this camcorder from other Sony VCRs to avoid remote control misoperation. If you use another Sony VCR at commander mode VTR 2, we recommend you change the commander mode or cover the remote sensor of the VCR with black paper.

Identifying the Parts

In the Viewfinder

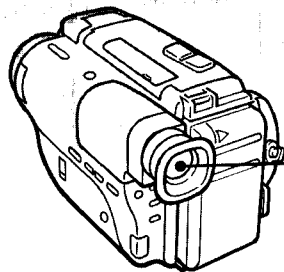

CCD-TR82

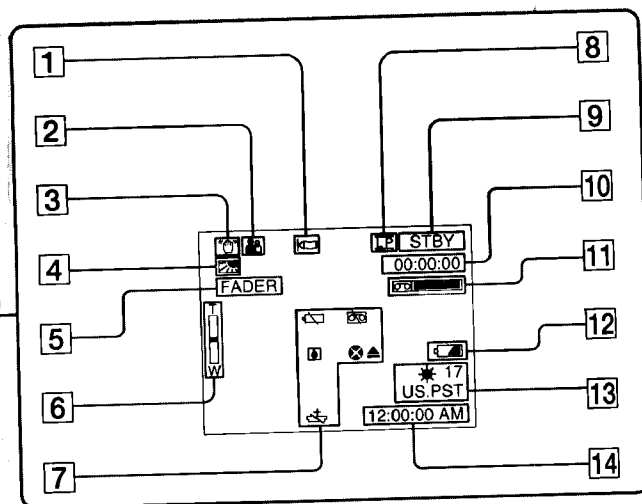

1 Wind noise reduction indicator (p.26)
(CCD-TR72/TR80 only)

2 PROGRAM AE mode indicator (p.22)

3 Steady Shot indicator (p.24)
(CCD-TR82 only)

4 Back light indicator (p.21)

5 FADER indicator (p.23)

6 Power zoom indicator (p.13)

7 Warning indicator (p.51)

8 Lights up when playing back a tape
recorded in LP mode (p.33)

9 Tape transport mode (p.11, 17)

10 Tape counter (p.12)

11 Tape remaining indicator

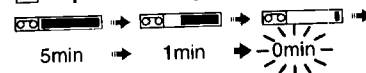

12 Battery remaining indicator (p.34)



13 World clock indicator (p.27)

14 Date or Time (p.20)

Warning Indicators

If indicators flash in the viewfinder, or a caution lamp on the camcorder flashes, check the following:

♪: You can hear the beep sound when the BEEP is set to ON.

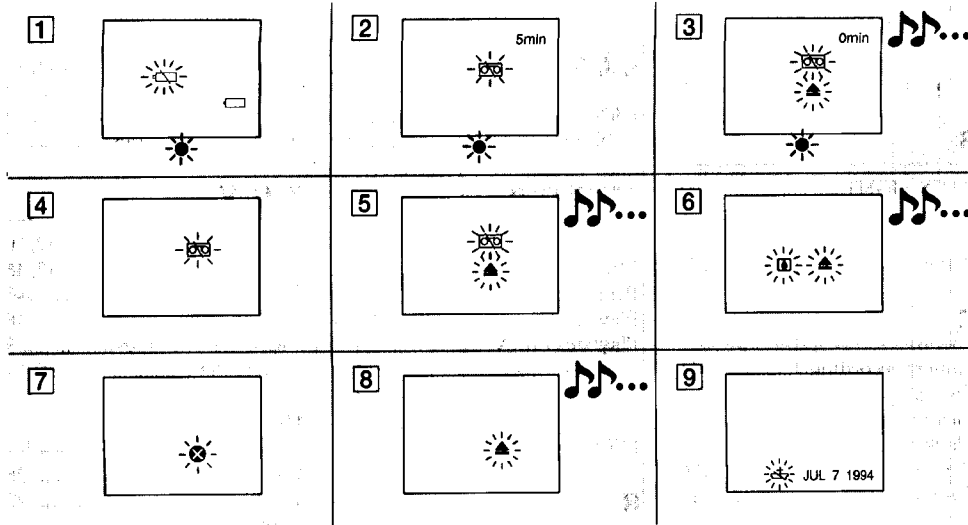

- | | |
|--|--|
| <p>1 Battery Remaining
Slow flashing: The battery is weak.
Fast flashing: The battery is dead.</p> <p>2 The tape is near the end.</p> <p>3 The tape has run out.</p> <p>4 No tape has been inserted.</p> <p>5 The tab on the tape is out (red) (p.9).</p> | <p>6 Moisture condensation has occurred (p.36).</p> <p>7 The video heads may be contaminated (p.37).</p> <p>8 Some other trouble has occurred.
Disconnect the power source and contact your Sony dealer or local authorized facility.</p> <p>9 The lithium battery is weak or the lithium battery is not installed (p.30).</p> |
|--|--|

Index

A

AC power adaptor	6, 19
Adjusting viewfinder	10
AFM Hi-Fi stereo	33
AUTO DATE	12
A/V connecting cable	16

B

BACK LIGHT	21
Battery	6, 19
Battery lamp	34
Battery pack	6, 33

C

Camera recording	11
Charging battery	6
Cleaning video heads	37
Clock set	31
Connection	16
Counter reset	12

D, E

DATE/TIME	20
Differences among the models	4
DISPLAY	18
Display window	50, 51
Editing	29
EDITSEARCH	15, 29
Ejection	9
External microphone jack	46
Eyecup	14

F, G, H

FADER	23
Fast-forward	18

I, J, K, L

LANC	46
Lithium battery	30

M, N, O, P

Menu system	25
MIC (microphone) jack	46
Pause button	18
Play	17, 21
Playback on TV	17
PLAYER mode	17
Power sources	6, 19
Power zoom	13
PROGRAM AE	22

R

Rec review	15
Recording lamp	11
Remote Commander	48
Remote control jack	46
Rewind	18
RFU adaptor	16
RFU DC output	16

S

Shoulder strap	46
Skip scan	18
Sports finder	14
andby	11, 12
STeady SHOT	24
Still picture	18
Supplied accessories	5

T, U, V

counter	12, 50
Tripod mounting	13, 46
Trouble check	40
VHF antenna	16
Video cassette tapes	9
viewfinder	10, 50, 51

W, X, Y, Z

Wind noise	26
World clock	27
Zoom	13

For Product information or operation, call:
SONY CUSTOMER INFORMATION CENTER
201-368-9272

or write to:
Sony Customer Information Center
One Sony Drive
Park Ridge, New Jersey 07656-8003
