

RCA

Color TV

55102114

Owner's Manual

model # P46728

P46729

P46730

First-Time Operation

pp. 2-7

*Complete Operator's
Guide and
Reference Manual*

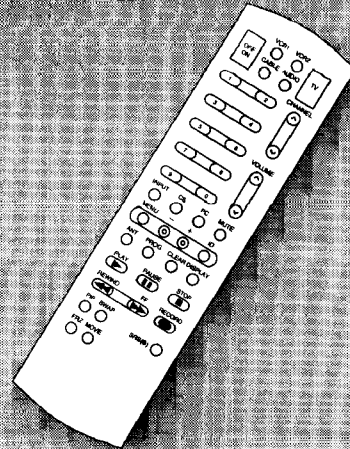

pp. 8-30

*Monitor Panel and
Detailed Connections*

pp. 31-45

Accessories and Order Form

pp. 46-48

Trouble Checks

pp. 49-51

Alphabetical Index

pp. 52-53

Product Registration

Please fill out the product registration card and return it immediately. Returning this card allows us to contact you if needed.

Keep your sales receipt to obtain warranty parts and service and for proof of purchase. Attach it here and record the serial and model numbers in case you every need them. The numbers are located on the bottom of your camcorder.

Model No. Pro808

Serial No. _____

Purchase Date: _____

Purchased From: _____

IMPORTANT SAFETY INSTRUCTIONS

AC Adapter/Charger

Before using the AC adapter/charger, read all instructions and cautionary markings on (1) AC adapter/charger, (2) battery, and (3) product using battery.

Caution: To reduce risk of injury, charge only rechargeable batteries type AV608 or AV8MM. Other types of batteries may burst causing personal injury and damage.

Do not expose the adapter/charger to moisture of any kind.

Use of an attachment not recommended or sold by the battery charger manufacturer may result in a risk of fire, electric shock, or injury to persons.

To reduce risk of damage to electric plug and cord, pull out the cord with the plug rather than the cord when disconnecting the adapter/charger from the wall outlet.

Make sure the cord is located so that it will not be stepped on, tripped over, or otherwise subjected to damage or stress.

Use of an improper extension cord could result in a risk of fire and electric shock. If an extension cord must be used, make sure that:

1. Pins on the plug of the extension cord are the same number, size, and shape as those of the plug on the adapter/charger.

2. Extension cord is properly wired and in good electrical condition, and

3. Wire size below is met:

Minimum AWG Size	Length of Extension Cord (Feet)
18	Equal to or less than 100
16	Equal to or less than 150

Do not operate adapter/charger with a damaged cord or plug. Replace it immediately.

Do not operate adapter/charger if it has received a sharp blow, been dropped, or otherwise damaged in any way. Take it to an Authorized RCA Compact Camcorder Servicenter.

Do not disassemble the adapter/charger. Take it to an Authorized RCA Compact Camcorder Servicenter when service or repair is required. Incorrect reassembly may result in a risk of electric shock.

To reduce risk of electric shock, unplug charger from outlet before attempting any maintenance or cleaning.

Be sure to save these operating instructions for future reference.

SAFETY PRECAUTIONS

Your video camcorder's AC adapter/charger will operate on 120-240 volts AC, 50/60 Hz, and has a polarized plug. Because one blade of the plug is wider than the other, the plug fits in the wall socket only one way. Do not defeat the safety feature of this plug. If you need an extension cord, use a polarized extension cord.

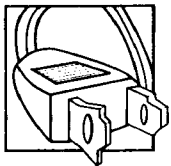

CAUTION: TO PREVENT ELECTRIC SHOCK, MATCH WIDE BLADE OF PLUG TO WIDE SLOT, FULLY INSERT.

MISE EN GARDE: POUR PRÉVENIR LES CHOCS ÉLECTRIQUES, INTRODUIRE LA LAME LA PLUS LARGE DE LA FICHE DANS LA BORNE CORRESPONDANTE DE LA PRISE ET POUSSER JUSQU'AU FOND.

CAUTION: TO REDUCE THE RISK OF ELECTRIC SHOCK, DO NOT REMOVE THE COVER (OR BACK). NO USER-SERVICEABLE PARTS ARE INSIDE. IF YOU SPILL LIQUID ON THE CAMCORDER OR ADAPTER/CHARGER, DISCONNECT THE AC ADAPTER/CHARGER'S POWER CORD TO PREVENT POSSIBLE FIRE OR SHOCK HAZARD AND CONSULT AUTHORIZED SERVICE PERSONNEL. MOISTURE CAN DAMAGE INTERNAL PARTS. REFER ALL SERVICE TO AUTHORIZED RCA COMPACT CAMCORDER SERVICENTER PERSONNEL ONLY.

CAUTION: READ "IMPORTANT SAFETY INSTRUCTIONS FOR AC ADAPTER/CHARGER" ON THE PREVIOUS PAGE BEFORE USING THE AC ADAPTER/CHARGER.

CAUTION: MAINTAIN ELECTRICAL SAFETY. POWERLINE-OPERATED EQUIPMENT OR ACCESSORIES CONNECTED TO THIS UNIT SHOULD BEAR THE UL LISTING MARK OR, IF PURCHASED IN CANADA, THE CSA CERTIFICATION MARK ON THE ACCESSORIES THEMSELVES AND SHOULD NOT HAVE BEEN MODIFIED SO AS TO DEFEAT THE SAFETY FEATURES. THIS WILL HELP AVOID ANY POTENTIAL HAZARD FROM ELECTRIC SHOCK OR FIRE. IF IN DOUBT, CONTACT QUALIFIED SERVICE PERSONNEL.

WARNING: TO PREVENT FIRE OR SHOCK HAZARD, DO NOT EXPOSE CAMCORDER OR AC ADAPTER/CHARGER TO RAIN OR MOISTURE.

CAUTION: AVOID OPERATING YOUR CAMCORDER IMMEDIATELY AFTER MOVING IT FROM A COLD LOCATION TO A WARM LOCATION. GIVE THE CAMCORDER 1-1/2 TO 2 HOURS TO REACH A STABLE TEMPERATURE BEFORE INSERTING A VIDEO CASSETTE. WHEN MOVED FROM A COLD AREA TO A WARM LOCATION, MOISTURE MAY CONDENSE ON THE HEAD DRUM INSIDE THE MACHINE. THIS MOISTURE COULD CAUSE THE TAPE TO STICK TO THE HEADWHEEL AND DAMAGE THE HEADWHEEL OR TAPE.

CAUTION

RISK OF ELECTRIC SHOCK
DO NOT OPEN



MISE EN GARDE

RISQUE DE CHOC ELECTRIQUE
NE PAS OUVRIR



The symbol of a lightning flash within a triangle is intended to alert the user to the presence of uninsulated "dangerous voltage" within the product's enclosure and which may be of sufficient magnitude to constitute a risk of electric shock.



An exclamation point within a triangle is intended to alert the user to the presence of important operating and maintenance (service) instructions in the literature accompanying the product.

CAUTION: FCC REGULATIONS STATE THAT ANY UNAUTHORIZED CHANGES OR MODIFICATIONS TO THIS EQUIPMENT MAY VOID THE USER'S AUTHORITY TO OPERATE IT.

IMPORTANT SAFEGUARDS

In addition to the careful attention devoted to quality standards in the manufacture of your video product, safety is a major factor in the design of every instrument. However, safety is your responsibility too.

These pages list important information that will help to assure your enjoyment and proper use of a camcorder, adapter/charger, and accessory equipment. Please read them carefully before operating your video products.

Installation

- 1. Read and Follow Instructions**—All the safety and operating instructions should be read before the video product is operated. Follow all operating instructions.
- 2. Retain Instructions**—The safety and operating instructions should be retained for future reference.
- 3. Heed Warnings**—Comply with all warnings on the video product and in the operating instructions.
- 4. Polarization**—This video product is equipped with a polarized alternating-current line plug (a plug having one blade wider than the other). This plug will fit into the power outlet only one way. This is a safety feature. If you are unable to insert the plug fully into the outlet, try reversing the plug. If the plug still fails to fit, contact your electrician to replace your obsolete outlet. To prevent electric shock, do not use this polarized plug with an extension cord, receptacle, or other outlet unless the blades can be fully inserted without blade exposure. If you need an extension cord, use one with a polarized plug.
- 5. Power Sources**—This video product should be operated only from the type of power source indicated on the marking label. If you are not sure of the type of power supply to your home, consult your video dealer or local power company. For video products intended to operate from battery power, or other sources, refer to the operating instructions.
- 6. Overloading**—Do not overload wall outlets or extension cords as this can result in a risk of fire or electric shock. Overloaded AC outlets, extension cords, frayed power cords, damaged or cracked wire insulation, and broken plugs are dangerous. They may result in a shock or fire hazard. Periodically examine the cord, and if its appearance indicates damage or deteriorated insulation, have it replaced by your service technician.
- 7. Power-Cord Protection**—Power-supply cords should be routed so that they are not likely to be walked on or pinched by items placed upon or

against them, paying particular attention to cords at plugs, convenience receptacles, and the point where they exit from the video product.

- 8. Ventilation**—Slots and openings in the video products are provided for ventilation to ensure reliable operation of the video product and to protect them from overheating. These openings must not be blocked or covered. The openings should never be blocked by placing the video product on a bed, sofa, rug, or other similar surface. This video product should never be placed near or over a radiator or heat register. This video product should not be placed in a built-in installation such as a bookcase or rack unless proper ventilation is provided or the video product manufacturer's instructions have been followed.
- 9. Attachments**—Do not use attachments unless recommended by the video product manufacturer as they may cause hazards.

Caution: Maintain electrical safety.

Powerline operated equipment or accessories connected to this unit should bear the UL listing mark or CSA certification mark on the accessory itself and should not be modified so as to defeat the safety features. This will help avoid any potential hazard from electrical shock or fire. If in doubt, contact qualified service personnel.

- 10. Water and Moisture**—Do not use this video product near water—for example, near a bath tub, wash bowl, kitchen sink or laundry tub, in a wet basement, or near a swimming pool and the like.
- 11. Accessories**—Do not place this video product on an unstable cart, stand, tripod, bracket, or table. The video product may fall, causing serious injury to a child or adult as well as serious damage to the video product. Use this video product only with a cart, stand, tripod, bracket, or table recommended by the manufacturer or sold with the video product. Any mounting of the product should follow the manufacturer's instructions and use a mounting accessory recommended by the manufacturer.
- 11A** A video product and cart combination should be moved with care. Quick stops, excessive force, and uneven surfaces may cause the video product and cart combination to overturn.



IMPORTANT SAFEGUARDS (continued)

12. Outdoor Antenna Grounding—If an outside antenna or cable system is connected to the video product, be sure the antenna or cable system is grounded so as to provide some protection against voltage surges and built-up static charges. Section 810 of the National Electrical Code, ANSI/NFPA No. 70-1984 (Section 54 of Canadian Electrical Code, Part 1) provides information with respect to proper grounding of the mast and supporting structure, grounding of the lead-in wire to an antenna-discharge unit, size of grounding conductors, location of antenna-discharge unit, connection to grounding electrodes, and requirements for the grounding electrode. See example below.

Example of Antenna Grounding

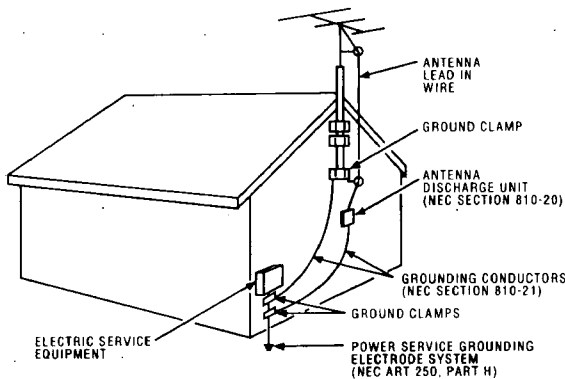

13. Power Lines—An outside antenna system should not be located in the vicinity of overhead power lines, other electric light or power circuits, or where it can fall into such power lines or circuits. When installing an outside antenna system, extreme care should be taken to keep from touching or approaching such power lines or circuits as contact with them might be fatal. Installing an outdoor antenna can be hazardous and should be left to a professional antenna installer.

Use

14. Cleaning—Unplug this video product from the wall outlet before cleaning. Do not use liquid cleaners or aerosol cleaners. Use a damp cloth for cleaning.

15. Object and Liquid Entry—Never push objects of any kind into this video product through openings as they may touch dangerous voltage points or “short-out” parts that could result in a fire or electric shock. Never spill liquid of any kind on the video product.

16. Lightning—For added protection for this video product during a lightning storm, or when it is left unattended and unused for long periods of time, unplug it from the wall outlet and disconnect the antenna or cable system. This will prevent damage to the video product due to lightning and power line surges.

Service

17. Servicing—Do not attempt to service this video product yourself as opening or removing covers may expose you to dangerous voltage or other hazards. Refer all servicing to qualified service personnel.

18. Conditions Requiring Service—Unplug this video product from the wall outlet and refer servicing to qualified service personnel under the following conditions.

- When the power-supply cord or plug is damaged.
- If liquid has been spilled, or objects have fallen into the video product.
- If the video product has been exposed to rain or water.
- If the video product does not operate normally by following the operating instructions. Adjust only those controls that are covered by the operating instructions. Improper adjustment of other controls may result in damage and will often require extensive work by a qualified technician to restore the video product to its normal operation.
- If the video product has been dropped or the case has been damaged.
- When the video product exhibits a distinct change in performance—this indicates a need for service.

19. Replacement Parts—When replacement parts are required, have the service technician verify that the replacements he uses have the same safety characteristics as the original parts. Use of replacements specified by the video product manufacturer can prevent fire, electric shock, or other hazards.

20. Safety Check—Upon completion of any service or repairs to this video product, ask the service technician to perform safety checks recommended by the manufacturer to determine that the video product is in safe operating condition.

Optional Accessories

To order accessories, contact your local dealer, call toll-free, or use the order form *on the next page*.

AC025A Soft Carrying Case

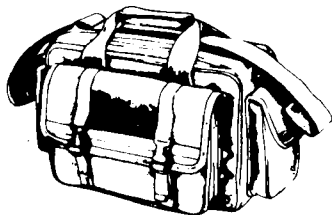

Custom compact soft case designed especially to provide protection and utility for your RCA 8mm camcorder and most accessories. Rugged fabric lined with soft

non-abrasive material and generous padding. Has three outside pockets with storage for lens filters, adapters, batteries, and tapes.

Rechargeable Batteries

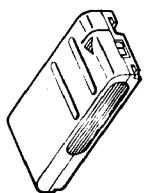

AV608

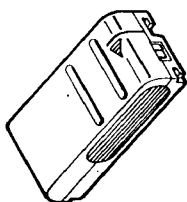

AV8MM

These rechargeable nickel-cadmium batteries are specifically designed for long life. The AV608 can power your camcorder up to one hour, and the

AV8MM up to two hours (depending on how much you use zoom and pause). Both can be recharged with the AC adapter/charger that came with your camcorder.

DCC05 Car Cord Adapter/Charger

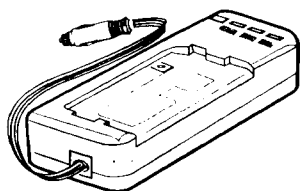

This car cord adapter/charger enables you to operate your camcorder from your car, truck, or RV by plugging the car cord directly into

the vehicle's cigarette lighter socket. It will also charge the AV608 battery supplied with the camcorder or the AV8MM long play battery. The DCC05 is specially designed to convert power from a 24-volt or 12-volt battery to a 6-volt output.

Caution: Do not use any other car cord with this camcorder. It may damage the camcorder.

VDC88 Color Enhancement Light

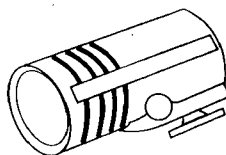

This ultra compact 15-watt video light is cordless, light in weight, and includes a rechargeable battery. It mounts on the top of the camcorder and fits on a standard accessory shoe.

The VDC88 provides excellent soft, lush fill light. It uses one 15-watt (VDC090) replacement bulb. The rechargeable battery BP1000 can be charged with the VDC085 battery charger.

VCC1000 Video Color Control Center

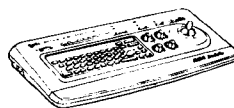

The VCC1000 is actually two accessories in one. The color control center allows you to adjust the color intensity, tint,

white balance, and sharpness of tapes being dubbed. This is especially helpful when the original tape was produced in poor lighting conditions or poor color settings. The second feature, the character generator, lets you create titles that can be recorded on your tapes. This lets you add a professional and/or personal touch to your home videos.

CRF800 RF Output Adapter

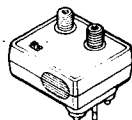

This adapter is used with coaxial RF cable (AH065G or AH066G) to connect your camcorder to a standard TV (one without audio/video input

jacks) for playback. If your antenna cable is the flat twin-lead type attached by two screws, you will also need a 300-75 ohm transformer such as 193983. If your TV has 300 ohm VHS screw terminals, you will need an optional 75-300 ohm transformer such as AH011.

Coaxial RF Cables



AH065G (6-ft)

AH066G (10-ft)

These RF cables are used with the CRF800 RF output adapter to connect your camcorder to a standard TV (one without audio/video input jacks) for playback.

If your antenna cable is the flat twin-lead type attached by two screws, you will also need a 300-75 ohm transformer such as 193983.

If your TV has 300 ohm VHS screw terminals, you will need an optional 75-300 ohm transformer such as AH011.

Accessory Order Form

193983 Cable Transformer

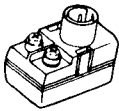

This 300-to-75 ohm transformer is used to connect a standard 300-ohm antenna

twin-lead to a standard round 75-ohm connector.

AH011 Cable Transformer

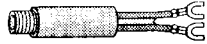

This 75-to-300 ohm transformer is used

to connect a standard 75-ohm antenna cable, such as AH065G or AH066G, to the 300-ohm screw terminals on a TV.

Audio/Video Cables



AH069G (3-ft)
AH070G (5-ft)

These cables are shielded for connecting *AUDIO* and *VIDEO* jacks. They have RCA-type phono plugs on each end.

Monaural VCR Dubbing Cable

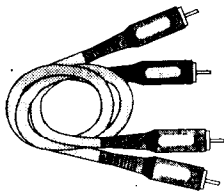

AH075G (6-ft)

This is a double cable that lets you connect the *AUDIO* and *VIDEO* jacks of monaural components. It can be used to connect your camcorder to a TV monitor (or VCR). The cable is color coded and shielded with RCA-type phono plugs on each end.

All specifications and descriptions of accessories are subject to change without notice.

Order Form for Pro808				
Description	Part No.	Price	Qty.	Total
Soft Camcorder Case	AC025A	\$ 59.95		
Super Lightweight Tripod	AC035	\$ 69.95		
Monopod	AC036	\$ 39.95		
Cable Transformer	AH011	\$ 1.90		
RF Coaxial Cable (6-ft.)	AH065G	\$ 6.99		
RF Coaxial Cable (10-ft.)	AH066G	\$ 8.99		
Audio/Video Cable (3-ft.)	AH069G	\$ 5.99		
Audio/Video Cable (5-ft.)	AH070G	\$ 7.99		
Dubbing Cable (6-ft.)	AH075G	\$ 10.99		
Rechargeable Battery	AV608	\$ 49.95		
Rechargeable Battery	AV8MM	\$ 59.95		
AC Adapter/Charger	CPS08	\$189.95		
RF Output Adapter	CRF800	\$ 49.95		
Car Cord Adapter/Charger	DCC05	\$169.95		
DC Cable for Adapter/Charger	DCC100	\$ 14.95		
Video Control Center	VCC1000	\$349.90		
Color Enhancement Light	VDC88	\$ 79.95		
Replacement Bulb (15 watt) for VDC88	VDC090	\$ 12.95		
Extra Battery for VDC88	BP1000	\$ 29.95		
Charger for BP1000	VDC085	\$ 18.95		
Cable Transformer	193983	\$ 6.95		
Replacement Remote Control	217495	\$ 49.95		
Shoulder Strap	213004	\$ 13.95		
Audio/Video Cable	217496	\$ 7.99		

Prices are subject to change without notice.

Total Merchandise (\$10 Minimum Order)..... \$ _____

Sales Tax..... \$ _____

We are required by law to collect the appropriate sales tax for each individual state, county, and locality to which the merchandise is being sent.

Shipping, Handling, and Insurance..... \$ 5.00

Total Amount Enclosed..... \$ _____

Use VISA or MasterCard preferably. Money order or check must be in U.S. currency only. No COD or CASH.

Detach Here



Please complete other side also

Accessory Order Form (continued)

Charge your order on your VISA
or MasterCard by
filling in below

USE YOUR CREDIT CARD

IMPORTANT: Copy complete account number
from your VISA card



My card expires:

IMPORTANT: Copy complete account number
from your MasterCard



Copy Number above your name on MasterCard:

My card expires:

AUTHORIZED SIGNATURE

Prices are subject to change without notice.

PLEASE

Print or type your name and address clearly. This will be your mailing label.

A complete and correct order will save you days of waiting.

Name: _____

Street: _____

_____ Apt: _____

City: _____

State: _____ Zip: _____

Please make sure that both sides of this form have been filled out completely.

To order accessories, contact your local Dealer.

If a dealer is not nearby, you can also follow the directions below to order by telephone or direct-by-mail.

United States and Canada Orders

To place your order by phone, have your Visa or MasterCard ready and call the toll-free number listed below between 8AM and 8PM Eastern Standard Time.

Use this number only to place an order for accessory items listed on this order form.

1 - 800 - 338 - 0376

Most times your order will be shipped UPS within 72 hours of receipt. If ever it is not possible to ship within 30 days, we will notify you with an update on your order and an option to cancel.

To place your order by mail, detach and mail the completed order form with credit card information, money order, or check in U.S. currency (made payable to Thomson Consumer Electronics, Inc.) to the following address:

RCA Video Accessories
PO Box 8419
Ronks, PA 17573

For more information on these accessories (or current prices), write to the following address:

Video Accessories Customer Service
Thomson Consumer Electronics, Inc.
Distributor & Special Products
2000 Clements Bridge Rd
Deptford, NJ 08096-2088

International Orders

This offer is valid only in the 50 United States. For international orders, please send your request for a price quotation (not an order) to:

International Customer Service
Thomson Consumer Electronics, Inc.
Distributor & Special Products
2000 Clements Bridge Rd
Deptford, NJ USA 08096-2088

✂ Detach Here

Optional Tripod or Monopod

AC035 Super Lightweight Tripod

This tripod's fluid-effect head provides smooth camera pan and tilt. The quick-release mount makes it easy to attach or remove the camcorder. The grooved, tubular 3-section leg design folds down to 23-1/2" when not in use and weighs only 3-1/2 lbs. Rubber feet allow for sure footing.

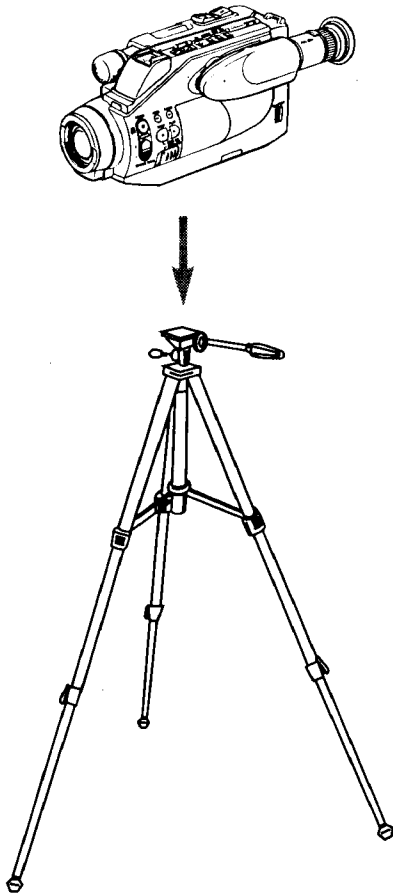

AC036 Monopod

This monopod gives a flexible alternative to using a traditional tripod. It is ideal for all camcorders and photo cameras. It has a quick release shoe, three-section leg, handstrap, foot step, and weighs only 35 ounces.

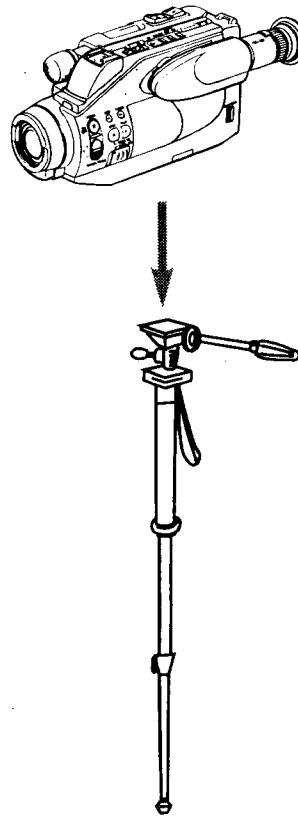

Cautions: Before using a tripod, make sure it is stable enough to hold the camcorder without falling over.

When attaching your camcorder to a tripod or monopod, be careful not to force their screw into the camcorder's mounting hole.

The tripod or monopod screw should not protrude into the camcorder more than approximately three-eighth (3/8) inch. Forcing the screw could damage the mounting hole on the bottom of the camcorder.

First-Time Operation

1. Unpack the camcorder and accessories.

- Save the packing materials and box in case you ever need to ship or store your camcorder.
- The items shown below are packed with your camcorder. If any are missing or appear damaged, contact your RCA dealer immediately.

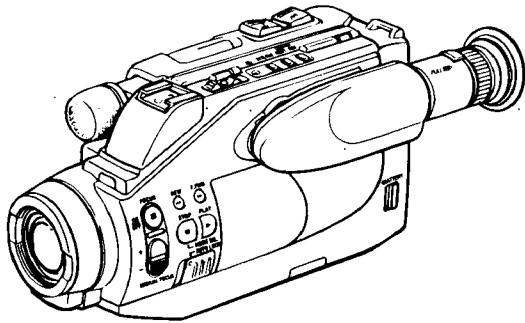

Camcorder
Model Pro808



Remote Control
Part No. 217495

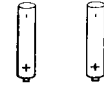

Remote Control Batteries
(Two "AA" 1.5 Volt)



Shoulder Strap
Part No. 213004

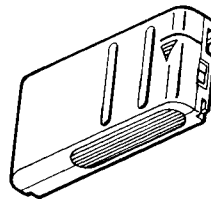

Rechargeable Battery
Part No. AV608

**WARNING: NICKEL
CADMIUM BATTERY
MUST BE DISPOSED
OF PROPERLY.**

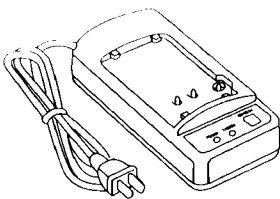

AC Adapter/Charger
Part No. CPS081

Caution:
Do not use this adapter/charger for any other purpose other than charging the AV608 or AV8MM battery pack or supplying power to the camcorder.

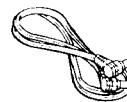

DC Connecting Cord
Part No. DCC100

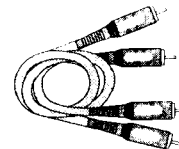

Audio/Video Output Cable
Part No. 217496



Clock Battery: 3-Volt Micro Lithium Cell Battery. Replace only with - Maxell No. CR2025 available from most local drug stores. Use of another cell may present a risk of fire or explosion.

Cautions: Lithium cell battery. Must be disposed of properly. Never handle punctured or leaking cells. May cause burns or personal injury. Keep out of the hands of children. Can cause death or injury if swallowed. If swallowed, consult a physician immediately for emergency treatment. The lithium cell used in this device may explode resulting in a fire or chemical burn if mistreated. Do not recharge, disassemble, heat above 212°F (100° C), or incinerate. Never use metallic tweezers to hold the cell, and never short circuit the + and - sides of the battery.

First-Time Operation (continued)

2. Attach a Power Supply: Adapter/Charger or Charged Battery.

A. Adapter/Charger

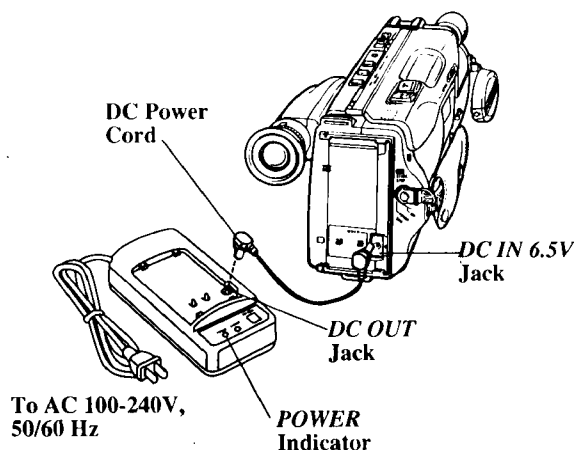

1. Connect one end of the DC power cord to the *DC OUT* jack on the adapter/charger and the other end to the *DC IN* 6.5V jack on the camcorder.
2. Plug in the adapter/charger. The adapter/charger's *POWER* indicator will light.

Details are on page 16.

B. Charged Battery*

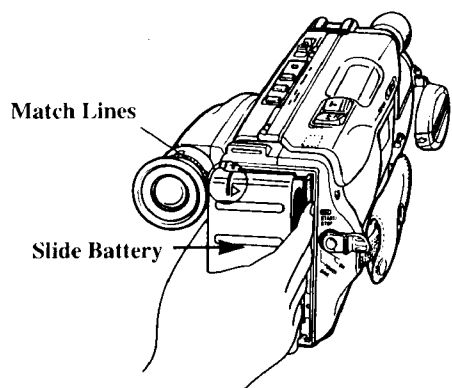

1. Make sure the camcorder's *POWER* switch is *OFF*.
2. Match the lines on the battery and camcorder.
3. Hold the battery flush against the camcorder, and slide it in the direction of the arrow until it locks into place.

* The battery must be charged before it can be used.
Details are on page 17.

3. Attach the shoulder strap.

- A. Unfasten one end of the shoulder strap from the buckle. Leave the buckle on the strap.



- B. Thread one end of the shoulder strap through one of the shoulder strap rings.

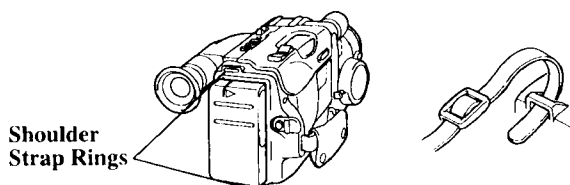

- C. Thread the strap back into the buckle. Pull on the strap and make sure it is securely fastened before using it to support the camcorder.

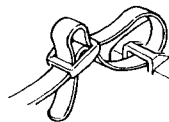

- D. Repeat steps A-C for the other end of the shoulder strap.

(continued on next page)

First-Time Operation (continued)

4. Attach lens cap to the lens cap holder.

A. Pull tab on side of the lens cap to remove it from lens on camcorder.

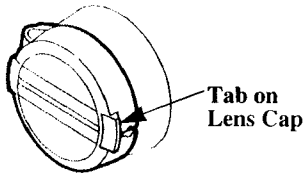

B. Pull tab end of the lens cap straight out and rotate it down.

C. Attach it to the lens cap holder on the side of the camcorder.

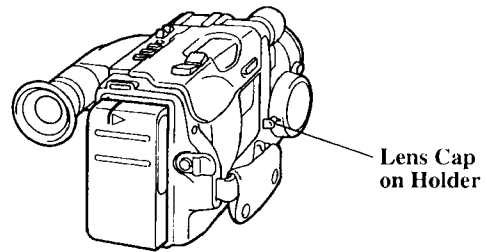

5. Adjust the hand strap.

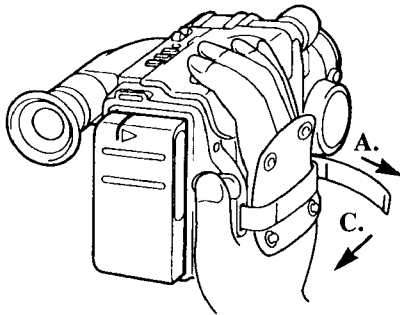

A. Unsnap the flap and open the adjustment strap.

B. Put your hand in the hand strap.

C. Pull the adjustment strap to tighten.

D. Snap the flap closed.

6. Insert a cassette in the camcorder.

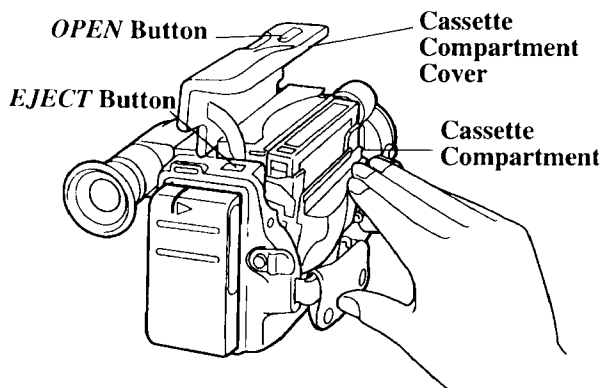

A. Slide the *OPEN* button, and completely open the cassette compartment cover.

B. Press the *EJECT* button to open the cassette compartment.

C. Insert a cassette with the safety tab facing up and the tape window facing out.

D. Gently press on the compartment where it is labeled *PUSH* until it locks into place.

E. After the cassette compartment is fully retracted, close the compartment cover.

First-Time Operation (continued)

7. Turn on the camcorder and place the *ON/POWER SAVE* lever *ON**.

POWER (CAM/OFF/PLAY) Switch

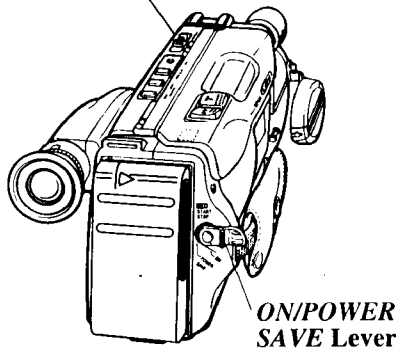

A. Press and hold the small button on the *POWER* switch while placing it in *CAM* (camera).

The position of the *POWER* switch tells the camcorder whether you want to record (*CAM*), play back tapes (*PLAY*), or turn off the camcorder's power (*OFF*).

B. Place the *ON/POWER SAVE* lever *ON*. This lever must be *ON* for the camcorder to record.

Place the *ON/POWER SAVE* lever in the *POWER SAVE* position during recording breaks to conserve battery power. The camcorder will enter record-pause.

* If the dew indicator  appears in the viewfinder, there is excessive moisture in the camcorder. Remove the cassette from the camcorder, and let it dry naturally.

Viewfinder in Operating Position (PULL out here.)

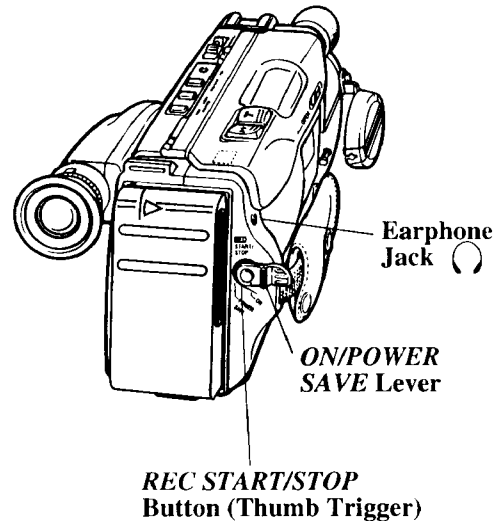
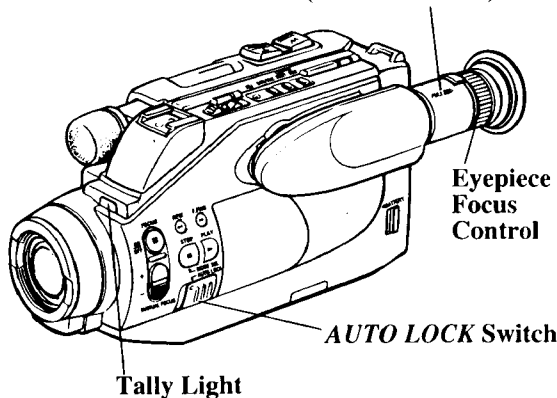

8. Set *AUTO LOCK* switch to *AUTO LOCK*.

9. Adjust viewfinder and eyepiece focus control.

- A. Pull the viewfinder into operating position.
- B. If the viewfinder picture is blurry, adjust the eyepiece focus control for your vision.

Details are on page 23.

10. Start and stop recording.

A. Press and release the *REC START/STOP* button (thumb trigger) to start and stop recording. *REC* appears in the viewfinder during recording.

B. To monitor the audio being recorded, attach an optional earphone to the earphone jack.

If you do not record within five minutes, the camcorder will automatically turn off.

The tally light flashes during record-pause and turns off when the camcorder is recording or the *ON/POWER SAVE* lever is in *POWER SAVE*.

First-Time Operation (continued)

11. Play back what you have recorded.

- A. Press the thumb trigger to stop recording.
- B. Place the *POWER* switch in *PLAY*.
- C. Press the *REW* button to rewind the tape.
- D. Press the *PLAY* button to play back the tape in the viewfinder.
- E. Press the *STOP* button when you are finished playing back the tape.

Details on viewfinder playback are on page 31.

12. Review the camcorder controls.

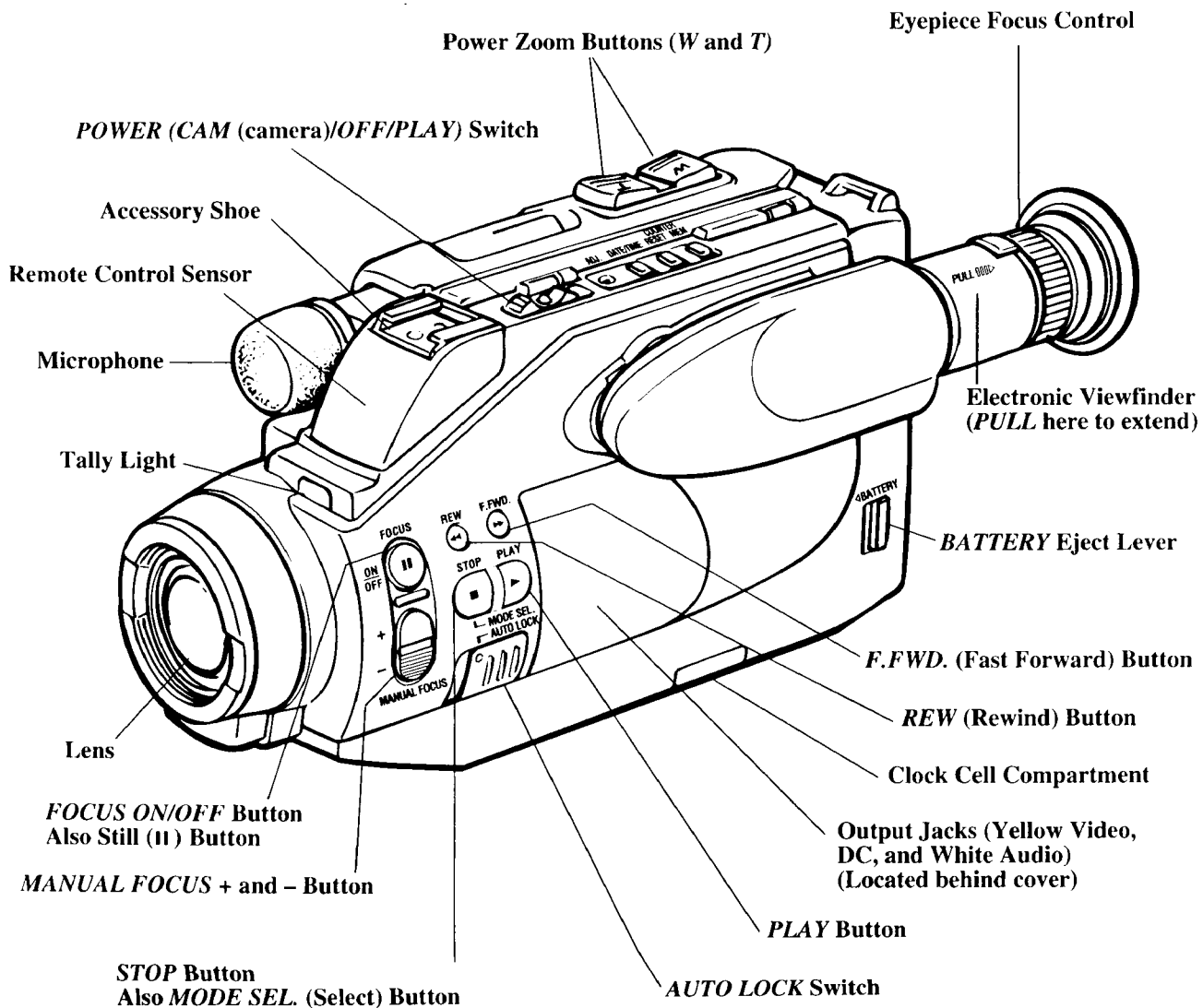

First-Time Operation (continued)

3072403 3308893

12. Review the camcorder controls. (continued)

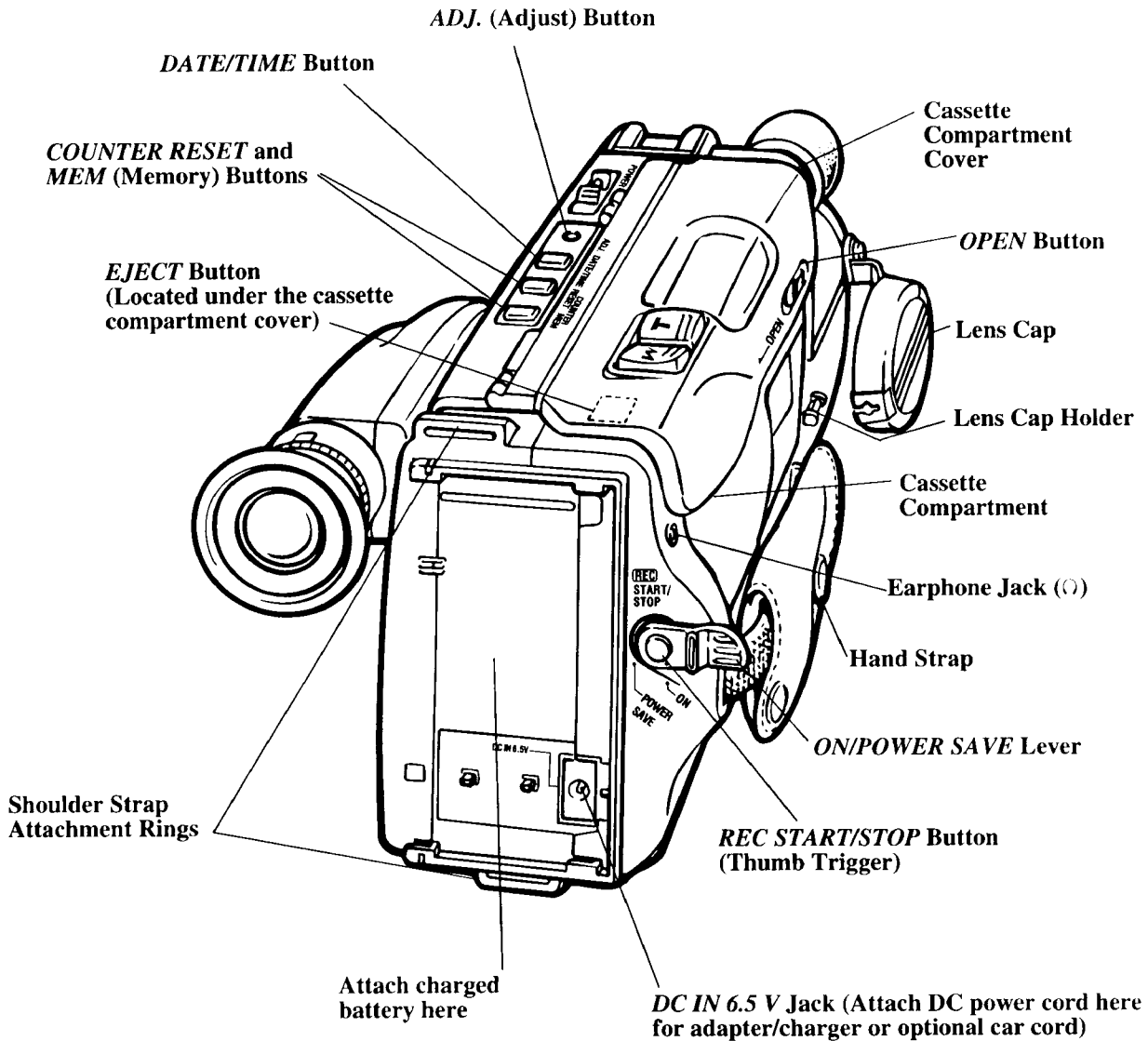

Remote Control

Install Remote Batteries

1. Turn the remote over and slide the battery compartment cover off.
2. Insert the batteries so their positive (+) ends contact the positive terminals in the battery compartment.
3. Replace the cover.

Notes: Never place anything heavy on top of the remote control or lay it upside-down.

Replace the batteries when the camcorder fails to respond to the remote control.

Remove the batteries from the remote control if it will not be used for a month or more. This will prevent possible damage from battery leakage. If leakage occurs, wipe up the liquid inside the compartment, and replace the batteries with new ones.

Do not use new and used batteries together. Different brands and types of batteries have different voltages and should not be used together.

Remote Control Sensor

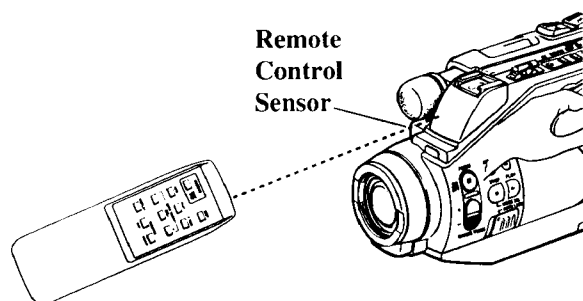

The remote control operates the camcorder by infrared light, so it is protected from electrical and sound interference. Aim the remote directly at the camcorder's remote control sensor. There cannot be any obstructions between them.

The remote should operate the camcorder up to approximately 16 feet away. Replace the remote batteries if the operation distance decreases.

Note: The camcorder may not respond to the remote if the camcorder's remote sensor is exposed to direct sunlight or strong artificial light.

Remote Buttons

Most of the remote control buttons perform the same function as the corresponding controls on the camcorder. You can use whichever are more convenient at the time.

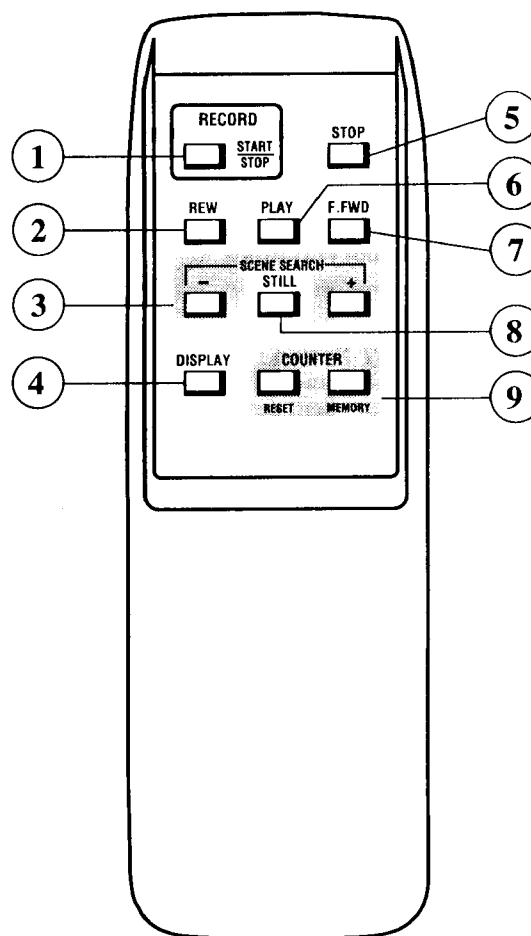

Note: An RCA VCR that responds to the VCR 2 button on the VCR's remote may respond to this remote control.

(continued on the next page)

Remote Buttons (continued)

① **RECORD START/STOP Button**

- Press and release the *RECORD START/STOP* button when the *POWER* switch is in *CAM* to start and stop recording.
- The tally light will light continuously during recording.

② **REW (Rewind) Button**

- Press the *REW* button when the camcorder's *POWER* switch is in *PLAY* to rewind the tape.
- During playback or rewind, press and hold the *REW* button to visually search the tape in reverse. Release the *REW* button to return to normal playback or rewind.

③ **SCENE SEARCH + and – Buttons**

- During record-pause, press and hold *SCENE SEARCH +* or *–* to visually search the tape in forward or reverse.
- Release the button to return to record-pause.

④ **DISPLAY Button**

- Press the *DISPLAY* button when the camcorder is connected to a TV to see the viewfinder's displays on the TV screen.
- Press the *DISPLAY* button again to remove them.

⑤ **STOP Button**

- Press this button when the camcorder's *POWER* switch is in *PLAY* to stop playback, rewind, or fast forward.
- The *STOP* button has no effect when the camcorder's *POWER* switch is in *CAM*. To stop recording, press the *RECORD START/STOP* button ①.

⑥ **PLAY Button**

Press the *PLAY* button when the camcorder's *POWER* switch is in *PLAY* to begin playback.

⑦ **F.FWD (Fast Forward) Button**

- Press the *F.FWD* button when the camcorder's *POWER* switch is in *PLAY* to fast forward the tape.
- During playback or fast-forward operation, press and hold the *F.FWD* button to visually search forward on the tape. Release the *F.FWD* button to return to normal playback or fast-forward operation.

⑧ **STILL Button**

- During playback, press the *STILL* button to produce a stop-action picture.
- Press the *STILL* button again to return to normal playback.
- This button has the same function as the still (II) button on the camcorder.

⑨ **COUNTER RESET and MEMORY Buttons**

- Press *COUNTER RESET* to reset the time counter to "0:00:00".
- Press *COUNTER MEMORY* to turn the memory-stop feature on and off.
- *Details are on page 28.*

Powering Your Camcorder

Adapter/Charger

The adapter/charger lets you power your camcorder directly from standard household power. It operates on 100-240 volts, 50/60 Hz, so it can be used virtually anywhere in the world to power the camcorder or recharge the battery. You may need a plug adapter in some countries. Consult your RCA dealer.

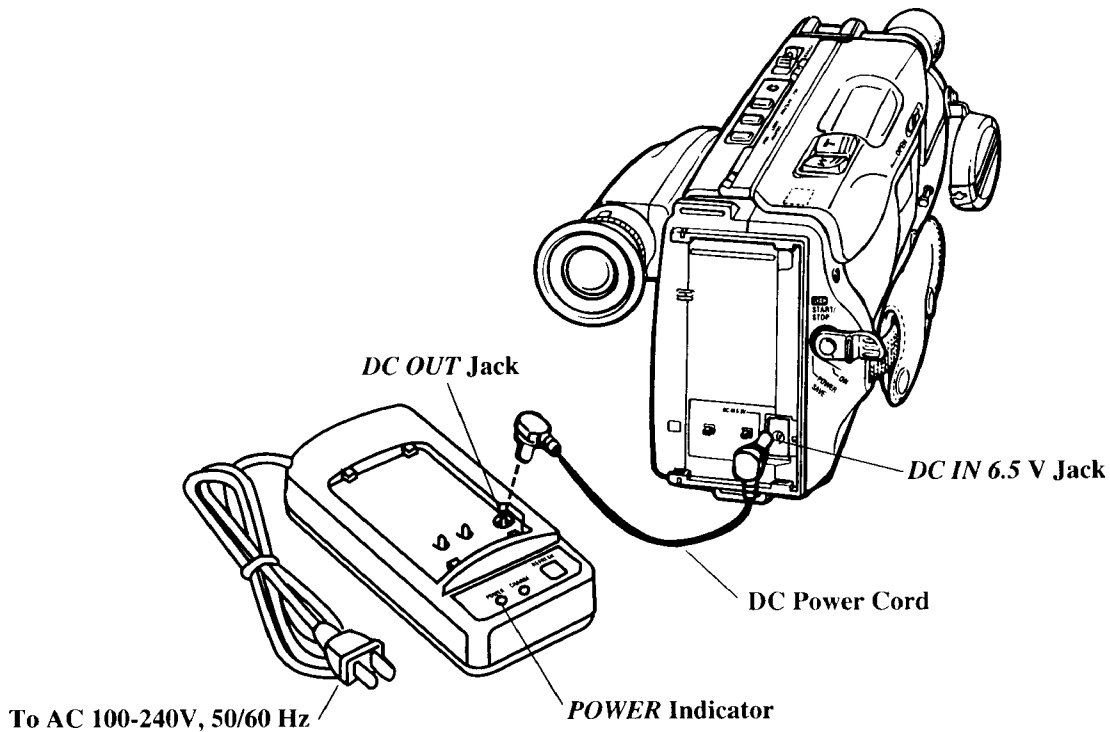

Use the Adapter/Charger

1. Plug one end of the DC power cord into the *DC OUT* jack on the adapter/charger and the other end to the *DC IN 6.5V* jack on the back of the camcorder.
2. Plug the adapter/charger's plug into the nearest AC outlet (100-240V, 50/60Hz). The *POWER* indicator will light.

Remove the Adapter/Charger

1. Unplug the adapter/charger from the wall outlet.
2. Disconnect the DC power cord from the camcorder and adapter/charger.

Using an Optional Plug Adapter

An optional plug adapter may be required in some countries.

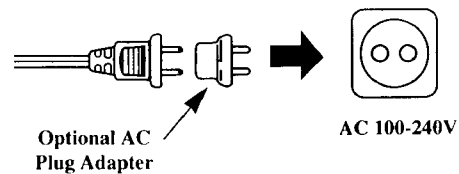

1. Plug the adapter/charger's plug into the AC plug adapter.
2. Plug the AC plug adapter into an AC outlet.

Powering Your Camcorder (continued)

Rechargeable Battery

The battery must be charged before it can be used the first time. Initial charging will take approximately one hour. When fully charged, the battery should supply about 45-60 minutes of operating time (depending on how much you use zoom and pause, auto focus, and record-pause).

Place the *ON/POWER SAVE* lever in *POWER SAVE* during recording breaks to conserve power. Place it back in *ON* when you are ready to resume recording.

Refresh and Charge the Battery

The nickel cadmium battery will provide longer operation time if it is refreshed (completely discharged) before every charging. Refreshing a battery will take approximately 3-1/2 hours.

Use the small marker switch on the top of the battery to help you remember to recharge the battery. It has no other function.

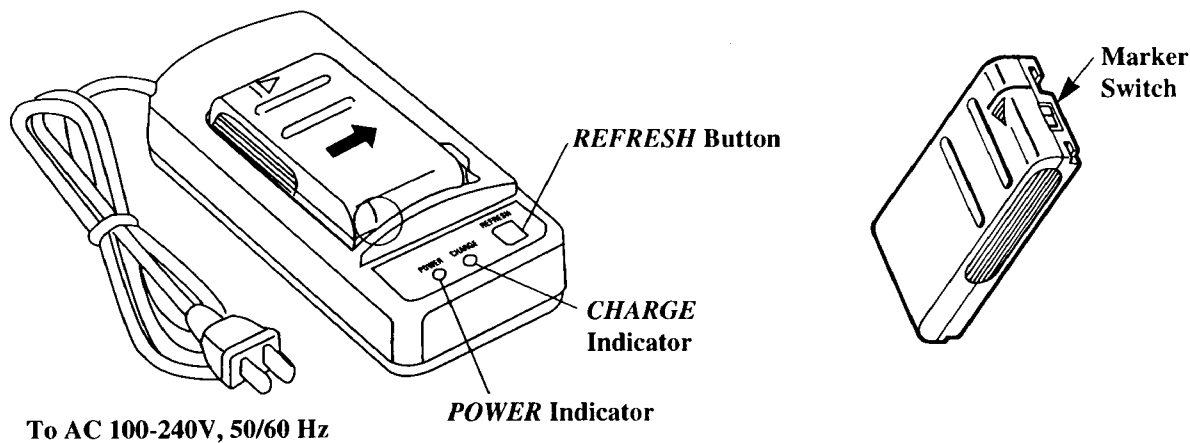

To AC 100-240V, 50/60 Hz

Caution: When a battery is attached to the adapter/charger, do not turn them upside down. The battery may fall off and be damaged or cause injury.

1. If the DC power cord's plug is connected to the adapter/charger, remove it.
2. Plug the adapter/charger into the nearest AC outlet (100-240V, 50/60Hz). The *POWER* indicator will light.
3. Align the reference marks on the battery and adapter/charger.
4. Hold the battery flush against the adapter/charger, and slide it in the direction of the arrow until it locks into place. The *CHARGE* indicator will light.
5. Press the *REFRESH* button to discharge the battery. After a few seconds, the *CHARGE*

indicator will flash slowly. It will stop flashing when the battery has been discharged. The *CHARGE* indicator will light and the battery will automatically recharge.

Note: If the *CHARGE* indicator starts flashing rapidly, remove the battery from the adapter/charger and try attaching it again.

6. Slide the charged battery off the adapter/charger to remove it. Unplug the AC power cord.

Important Note:

Spent nickel-cadmium rechargeable battery must be recycled or disposed of properly in compliance with all applicable laws. For detailed information, contact your local county solid waste authority.

Powering Your Camcorder (continued)

Rechargeable Battery (continued)

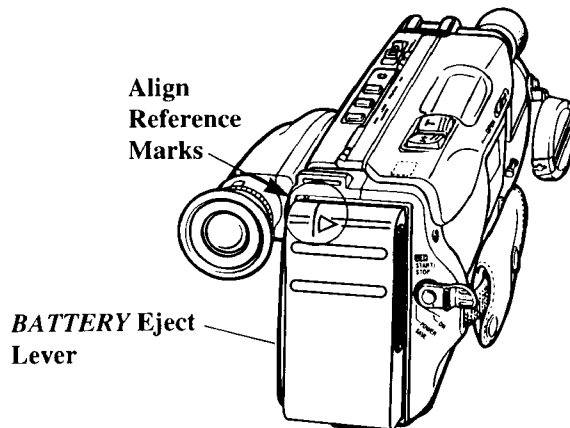

**WARNING: NICKEL
CADMIUM BATTERY
MUST BE DISPOSED
OF PROPERLY.**

Attach the Charged Battery

1. If the DC power cord's plug is attached to the camcorder, remove it.
2. Align the reference marks on the battery and camcorder.
3. Hold the battery flush against the camcorder, and slide it in the direction of the arrow.
4. Slide the camcorder's *POWER* switch to *CAM*, and place the *ON/POWER SAVE* lever *ON*.

Remove the Battery

1. Slide and hold the *BATTERY* eject lever on the camcorder while sliding the battery to the left and off the camcorder.

Battery Safety Precautions

Do not short the battery's terminals.

Do not attempt to disassemble or modify the battery. There are no user-serviceable parts inside.

Use the battery only with specified RCA adapter/chargers and camcorders.

Low Battery Warning

The low battery warning (⏻) appears when battery power is low. Recharge the battery or use the adapter/charger to power the camcorder.

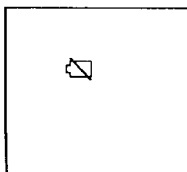

Low Battery Warning
in Viewfinder

Caution: The camcorder will shut off when the battery reaches empty. The battery should still eject the cassette when you press the *EJECT* button. If it does not, do not attempt to force the cassette compartment open. This will damage the camcorder.

Powering Your Camcorder (continued)

Optional RCA DCC05 Car Cord Adapter/Charger

This adapter/charger allows you to power your camcorder from the cigarette lighter socket of a car, truck, or RV. It converts 24- and 12-volts to a 6-volt output. It can also charge the battery that came with your camcorder and the AV8MM (long play) battery.

Consult the instructions enclosed with the DCC05 for complete operation information.

Using the RCA DCC05 Car Cord Adapter/Charger to Power the Camcorder

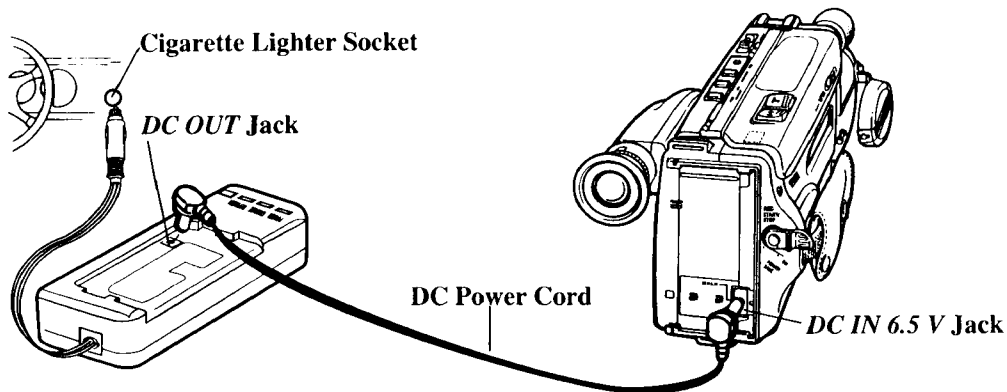

1. Remove battery if it is attached to the camcorder or car cord adapter/charger.
2. Plug one end of the DC power cord into the *DC OUT* jack on the car cord adapter/charger and the other end into the *DC IN 6.5 V* jack on the back of the camcorder.
3. Insert the DCC05's plug into the vehicle's cigarette lighter socket. The *POWER* indicator on the DCC05 will light.

Cautions: The DCC05 is designed to be used only with vehicles having negative ground electrical systems.

Do not use any other car cord with this camcorder. Other car cords may damage your camcorder.

Using the RCA DCC05 Car Cord Adapter/Charger to Charge the Battery

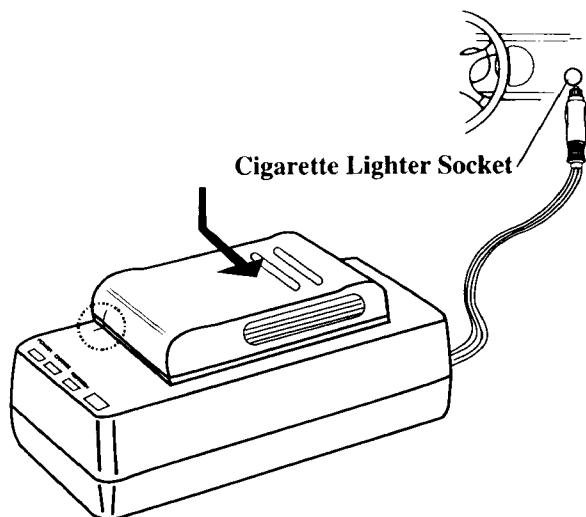

1. Remove DC power cord if it is attached.
2. Attach the battery as shown.
3. Insert the DCC05's plug into the cigarette lighter socket. The *POWER* indicator on the DCC05 will light.

RCA Video Cassettes

We recommend RCA cassettes be used with your camcorder. Use of poor quality or damaged tapes can contaminate the video heads, resulting in snow or no picture during playback. Head cleaning is not covered under warranty. It is considered normal maintenance. Playing a new RCA tape for approximately 30 minutes will often satisfactorily clean the heads and improve your picture.

Insert and Remove Cassettes

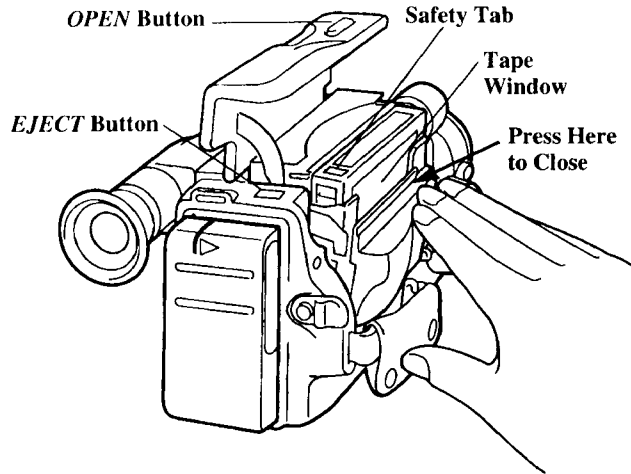

1. Attach a power supply to the camcorder.
2. Slide the *OPEN* button and completely open the cassette compartment cover.
3. Press the *EJECT* button to open the cassette compartment. Insert or remove the cassette.

Caution: Insert the cassette with the safety tab facing up and the tape window facing out. The cassette should slide easily in the compartment. Do not force the cassette.

4. Gently press on the area labeled *PUSH* to close the cassette compartment door.
5. After the cassette compartment is fully retracted, close the cassette compartment cover.

Erase Protection—Safety Tab

You can use your video cassettes over and over again. To erase a previous recording, just record over it.

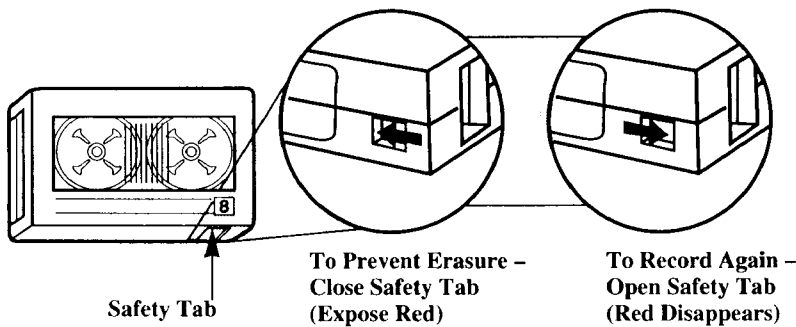

Recording and Playback Speeds and Times

The camcorder records in standard speed (SP). The chart shows the maximum SP recording times for some popular 8mm cassettes.

The camcorder can play back tapes in standard speed (SP) or long play (LP) speed. The playback speed is automatically selected by the camcorder. The *LP* indicator appears in the electronic viewfinder when the camcorder is playing back a tape recorded in LP.

Cassette	Recording Time
P6-15	15 Minutes
P6-20	20 Minutes
P6-45	45 Minutes
P6-60	60 Minutes
P6-90	90 Minutes
P6-120	2 Hours
P6-150	2 1/2 Hours

Special Features

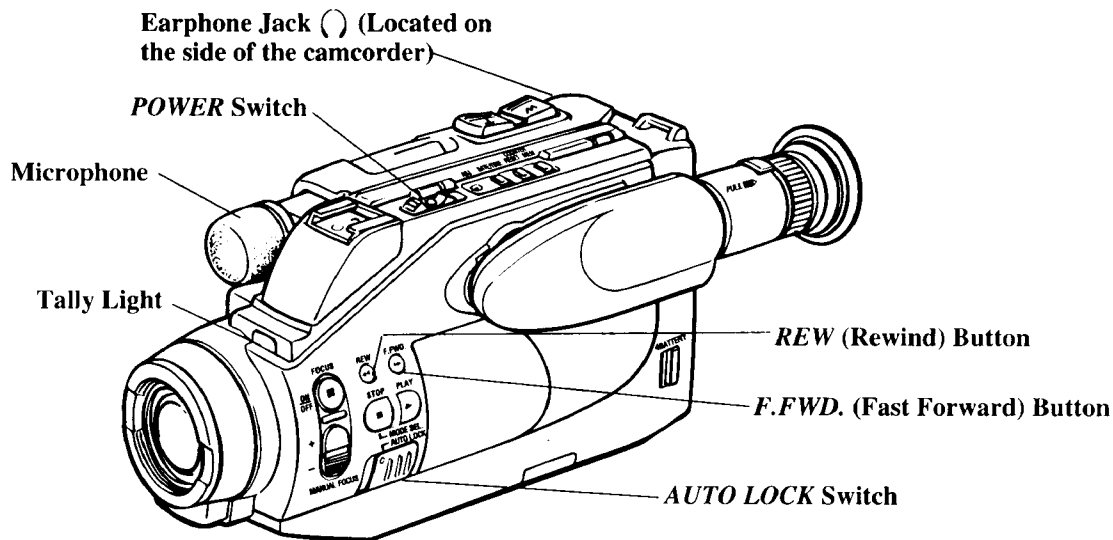

Camera Edit

This feature lets you position the tape while the camcorder is in record-pause.

- Press and hold the *REW* button on the camcorder (or the *SCENE SEARCH -* button on the remote control) to visually search the recorded tape in reverse.
- Press and hold the *F.FWD.* (fast forward) button on the camcorder (or the *SCENE SEARCH +* button on the remote control) to visually search forward on the recorded tape.

Release the button to have the camcorder return to the record-pause mode at that point on the tape.

Quick Review

When the camcorder is in the record-pause mode, press and release the *REW* button to review the last few seconds of recorded material. The camcorder will return to the record-pause mode.

Note: Do not hold the *REW* button, or the camcorder will go into camera edit.

Flying Erase Head

A separate erase head is mounted on the spinning headwheel (hence the term “flying”). This allows you to make clean edits without the “glitches” or “rainbow noise” that may occur at the beginning and end of each recording.

Earphone Jack ()

Plug an optional earphone into this jack to privately listen while recording or playing back a tape.

AUTO LOCK Switch

Place the *AUTO LOCK* switch in *AUTO LOCK* to have the camcorder control focus and the preset program modes.

When you begin recording, the *REC* and *PAUSE* indicators will appear briefly in the viewfinder twice their normal size.

Tape Positioning

Place the *POWER* switch in *PLAY*, and make sure the camcorder is stopped.

- Press the *F.FWD.* button to fast-forward the tape.
- Press the *REW* button to rewind the tape.

Press the *STOP* button to stop fast-forward or rewind.

Microphone

The microphone picks up the sound during a recording. It is more sensitive to sounds coming from the direction the lens is pointed.

Tally Light

The tally light flashes when the camcorder is in record-pause.

- The tally light will turn off if you start recording with the thumb trigger on the camcorder or place the *ON/POWER SAVE* lever in *POWER SAVE*.
- The tally light will light continuously if you start recording with the *RECORD START/STOP* button on the remote control.

Date and Time Display

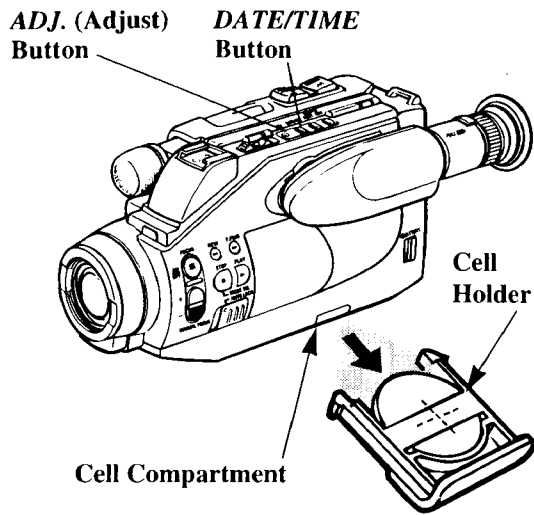

Display in Viewfinder

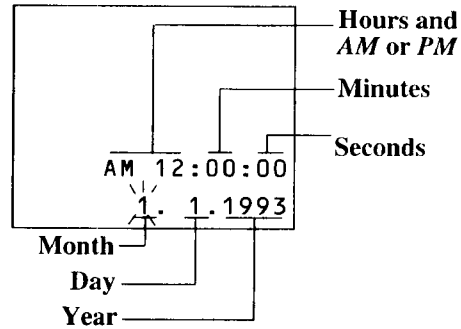

Install the Lithium Cell for Time and Date Display

1. Pull out the cell holder.
2. Insert the cell with the "+" terminal up.
3. Replace the cell holder.

Note: The lithium cell should last about one year. When it expires, the date display shows "88:88". Reset the date and time after replacing the cell.

Cautions: Lithium cell battery. Must be disposed of properly. Never handle punctured or leaking cells. May cause burns or personal injury.

Keep out of the hands of children. Can cause death or injury if swallowed. If swallowed, consult a physician immediately for emergency treatment.

The lithium cell used in this device may explode resulting in a fire or chemical burn if mistreated. Do not recharge, disassemble, heat above 212°F (100° C), or incinerate.

Never use metallic tweezers to hold the cell, and never short circuit the + and - sides of the battery.

Set and Record the Time and Date

Record the Time and Date

Whenever time and date or date appear in the viewfinder, it will be recorded on the tape. Press the *DATE/TIME* button to display and remove the time and date.

Press <i>DATE/TIME</i> Button	To Display in Viewfinder and Record on the Tape
Press Once	Date Only
Press Again	Date and Time
Press Again	Neither Date nor Time

Set the Time and Date

1. Install the lithium cell *as described above*.
 2. Attach a power supply to the camcorder. Press and hold the small button on the *POWER* switch while you slide it to *CAM*. Place the *ON/POWER SAVE* lever in *ON*.
 3. Use a straightened paper clip or pen to press and hold the *ADJ.* (adjust) button for about one second. The reset date (1. 1. 1993) and time (AM 12:00:00) will appear in the viewfinder.
 4. The month will flash. Repeatedly press *DATE/TIME* button until the correct month appears.
 5. Then, press the *ADJ.* button. The flashing cursor will move to the next part of the display.
 6. Repeat steps 4 and 5 until you have entered the correct month, day, year, hour including *AM* or *PM*, and minute.
 7. After setting the minutes, press the *ADJ.* button to start the seconds. The seconds counter will start with "00".
- To correct the date or time after the clock has been started, repeat steps 3-7.

Viewfinder

The camcorder's viewfinder is a miniature black-and-white monitor that displays the picture seen by the camcorder. The viewfinder can also be used for viewing the tape during playback.

Caution: When carrying the camcorder with the shoulder strap, rotate the viewfinder down. This helps prevent possible damage to the viewfinder from bumping against your body as you move.

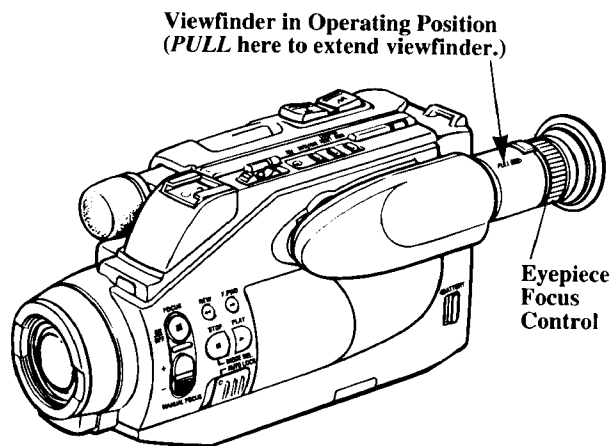

Eyepiece Focus Control

The eyepiece focus control lets you set the focus of the viewfinder for your personal vision. If you wear eyeglasses, you can probably operate the camcorder without them.

The eyepiece focus control does not affect the focus of the picture actually recorded by the camcorder.

To adjust the focus, follow the steps below.

1. Pull the viewfinder out into operating position.
2. Turn the eyepiece focus control until you clearly focus on one of the viewfinder displays (such as date).

Tilt Adjustment

For convenient viewing, the viewfinder can be raised approximately 90°.

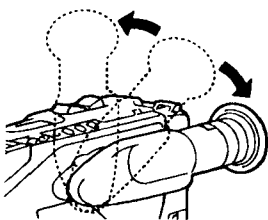

Caution: Do not force the viewfinder to rotate completely around. This will damage the viewfinder and/or the camcorder.

Cleaning the Viewfinder

To clean the viewfinder, follow the steps below.

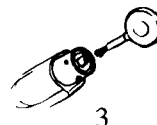

1. Fully extend the viewfinder, and then push it back slightly.

2. Rotate the eyecup counterclockwise to remove it.

3. Use an optional air blower, available from most camera stores, to clean the viewfinder.

Displays in Viewfinder

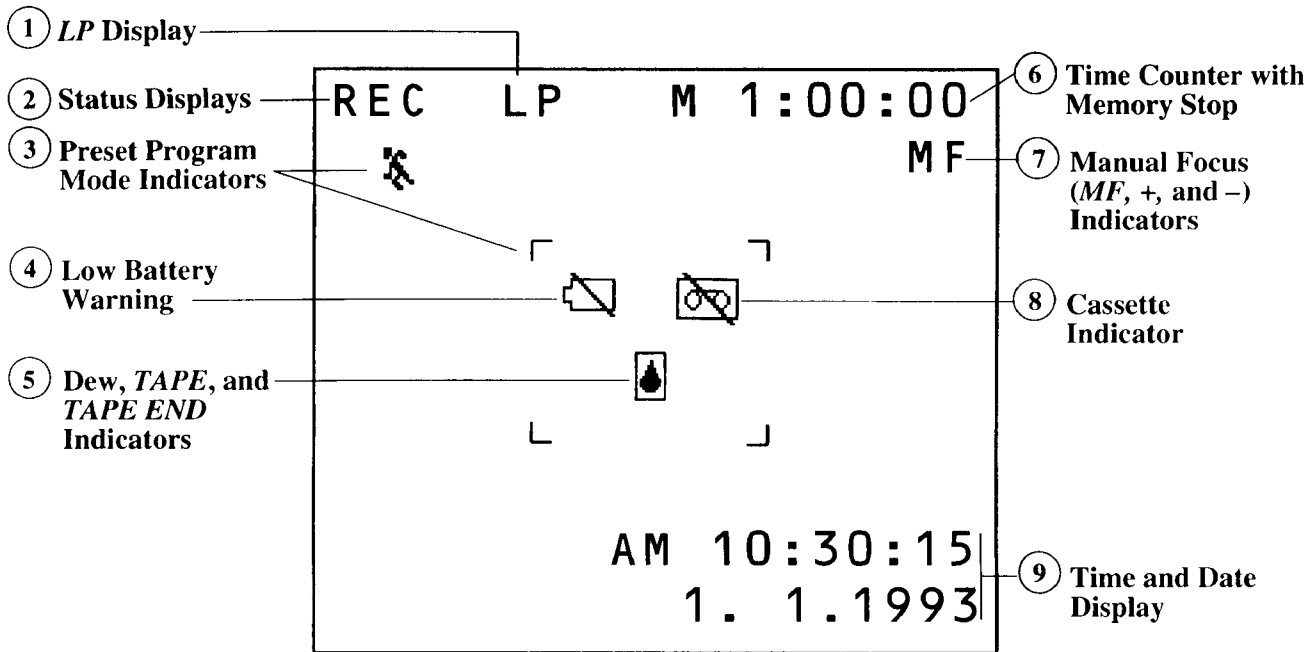

Displays in Viewfinder

1 LP Indicator

LP appears when you play back a tape recorded in LP speed.

2 Status Displays

- *REC* appears when the camcorder is recording.
- *PAUSE* flashes when the camcorder is in record-pause.
- *FF* appears when the tape is fast forwarding, and *REW* appears when the tape is rewinding.
- *STOP* appears when the camcorder is stopped during playback.
- *PLAY* appears when the camcorder is playing back a tape.
- A larger *REC* or *PAUSE* briefly flashes below the status display area when you start or stop recording to let you know that the *AUTO LOCK* switch is in *AUTO LOCK*.
- These displays are not recorded on the tape.

3 Preset Program Mode Indicators

- Repeatedly press the *MODE SEL.* button to select one of the camcorder's preset program modes. The *AUTO LOCK* switch must be out of *AUTO LOCK*.

- The indicator for the mode selected will appear in the viewfinder. No indicator appears when auto mode is selected.

- The indicator is not recorded on the tape.

• *Details are on page 27.*

4 Low Battery Warning

- The low battery warning appears when it is time to recharge the battery pack.
- This indicator is not recorded on the tape.

5 Dew , TAPE and TAPE END Indicators

- The dew indicator appears when excessive moisture is in the camcorder or cassette. The camcorder's buttons will not operate except to eject the cassette. Press the *EJECT* button and remove the cassette from the camcorder. Place the camcorder in a warm, dry area until the  indicator disappears (approximately one hour). When it disappears, the camcorder will operate.
- *TAPE* appears when approximately five minutes of recording time is left on the tape.
- *TAPE END* appears when the end of the tape is reached during recording.

6 Time Counter with Memory Stop



The time counter appears here during recording and playback.

- Press the *COUNTER RESET* button to reset the counter to “0:00:00” when you start recording or playing back a tape.
- Press the *COUNTER MEM* (memory) button to turn memory stop on or off. An *M* appears in front of the time counter when memory stop is on.
- These displays are not recorded when they appear.
- *Details are on page 28.*

7 Manual Focus Indicators

- Press the *FOCUS ON/OFF* button to turn off auto focus and focus manually. The *AUTO LOCK* switch must be out of *AUTO LOCK*. The *MF* indicator will appear in the viewfinder during manual focus.
- *MF+* or *MF-* will appear when using the *MANUAL FOCUS -* or *+* button.
- This display is not recorded when it appears.
- Press the *FOCUS ON/OFF* button again to return to auto focus. No indicator appears when using auto focus.

8 Cassette Indicator

-  appears if there is no cassette in the camcorder or if you try to record on a cassette that has its safety tab closed.
-  appears if there is moisture in the cassette.

9 Time and Date Display

- Press the *DATE/TIME* button to display or remove the time and date (or date) from the viewfinder after they are set. The *POWER* switch must be in *CAM*.
- This display will be recorded on the tape whenever it appears.
- “88:88” appears if the time and date have not been set or when the clock battery is not installed correctly or needs replacing.
- *Details are on page 22.*

Power Zoom Buttons

T=Telephoto

W=Wide Angle

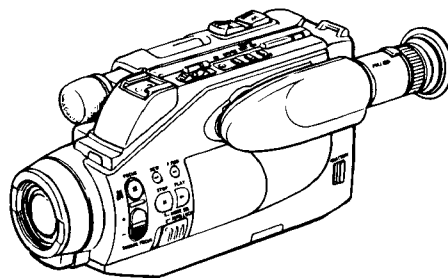

The 8:1 motorized zoom lens allows you to zoom in and out for close-ups or wide-angle shots by pressing one of the power zoom buttons.

- Press the button labeled “T” to move the lens in the telephoto (close-up) direction.
- Press the button labeled “W” to move the lens in the wide-angle direction.

Notes: Image vibration is more noticeable when zooming in to film close-up shots. If possible use a tripod or make sure the camcorder is kept steady.

When the camcorder’s *POWER* switch is placed in *OFF*, the zoom ratio will automatically return to full wide-angle.

When you place the *ON/POWER SAVE* lever in *POWER SAVE* and then back in *ON*, the zoom ratio will remain the same as before you put it in *POWER SAVE*.

Focusing Your Camcorder

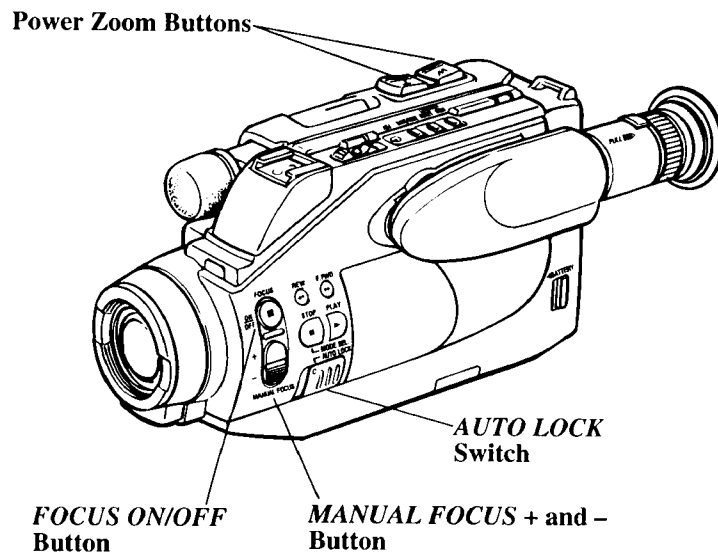

Auto Focus

If you want the camcorder to focus for you automatically, set the *AUTO LOCK* switch to *AUTO LOCK*.

The camcorder will automatically focus on any subject three feet or more from the lens. For a subject closer than three feet, press "W" to change to wide-angle where the subject will be in focus.

Manual Focus

Certain conditions require manual focusing.

- When taping two subjects – one near and one distant.
- When taping subjects in very low light.
- When taping a horizontally striped subject.
- When taping subjects with little or no contrast.

To focus manually.

1. Slide the *AUTO LOCK* switch to *AUTO LOCK*.
2. Press power zoom button "T" and zoom in on the subject.
3. Press the *FOCUS ON/OFF* button to select manual focus. *MF* will appear in the viewfinder.
4. Press the + or – side of the *MANUAL FOCUS +/-* button to adjust the focus.
 - *MF+* will appear in the viewfinder when focusing in the + direction.
 - *MF-* will appear in the viewfinder when focusing in the – direction.
5. Use the power zoom buttons to select desired zooming range.

Note: When the *POWER* switch is *OFF*, focus will reset to auto when power is restored. Manual focus will remain selected when you place the *ON/POWER SAVE* lever in *POWER SAVE* and then restore power by placing it *ON*.

Preset Program Modes

The camcorder has several preset program modes for particular recording situations. It will automatically set shutter speed, white balance, and iris. Manual or auto-focus can be used during any of these modes.

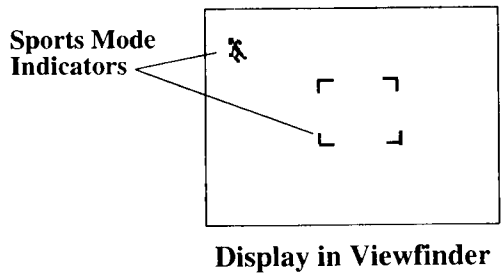
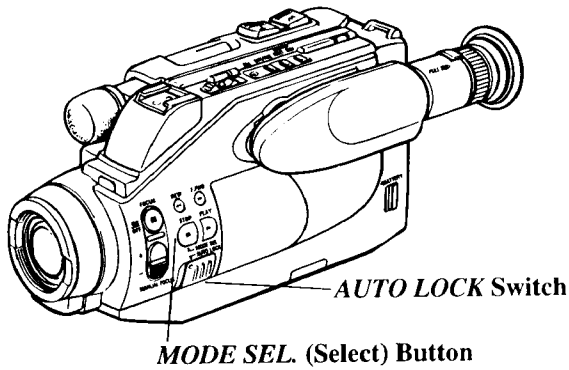





To select a preset program mode

1. Place the camcorder in record-pause.
2. Slide the *AUTO LOCK* switch to *AUTO LOCK*.
3. Repeatedly press the *MODE SEL.* (select) button to select the mode that best fits the conditions.

See the chart below to decide which mode to use.

Notes: If you want the camcorder to remember the mode you selected during recording breaks, place the *ON/POWER SAVE* lever in *POWER SAVE*. The settings will automatically return to auto if the power is turned off using the *POWER* switch.

Auto focus will automatically reset whenever you select a new preset program mode.

Mode	Shutter Speed	Indicator	Auto-Focus Area	Recording Conditions
Auto mode	1/60 second.	None	Normal	Use under normal conditions.
Sports	1/60 ~ 1/250 second. (depending on brightness)		Center Frame Area Only (9 feet and farther)	For filming sporting events, football games, etc. • Colors may change if this mode is used indoors with fluorescent lighting.
Auto high speed shutter	1/250 ~ 1/10,000 second (depending on brightness)		Normal	For capturing fast movements such as a golf swing, tennis swing, etc. • Colors may change if this mode is used indoors with fluorescent lighting.
Close-up	1/60 second		2/5 inch~78 inches	For filming subjects, such as flowers or insects, at a short distance. • This mode automatically sets the zoom to the wide-angle position and focus to about 2 inches from the lens. The focus can then be adjusted on any subject in a range of 2/5 inch to 78 inches from the lens.
Low Light	1/60 second		Normal	For best results when filming indoors, under low light conditions. • If the camcorder makes too many focus adjustments, this may indicate that the subject is too bright. In this case select the auto mode shown above or use manual focus.
Flickerless	1/100 second		Normal	When recording in a foreign country under fluorescent lighting that uses 50 Hz. electric current (some parts of Europe and Asia).

Time Counter with Memory Stop

The time counter display shows the actual time elapsed when recording or playing back a tape. The time counter quickly locates the end of recorded segments. Note the reading when you are finished recording or playing back a tape. Before you start to record or playback a tape, press the *COUNTER RESET* button to set the counter to "0:00:00".

For example, you recorded a 10-minute segment. Later, you want to locate the end of your recording. Insert the cassette and fast-forward the tape until the time counter reads "0:10:00".

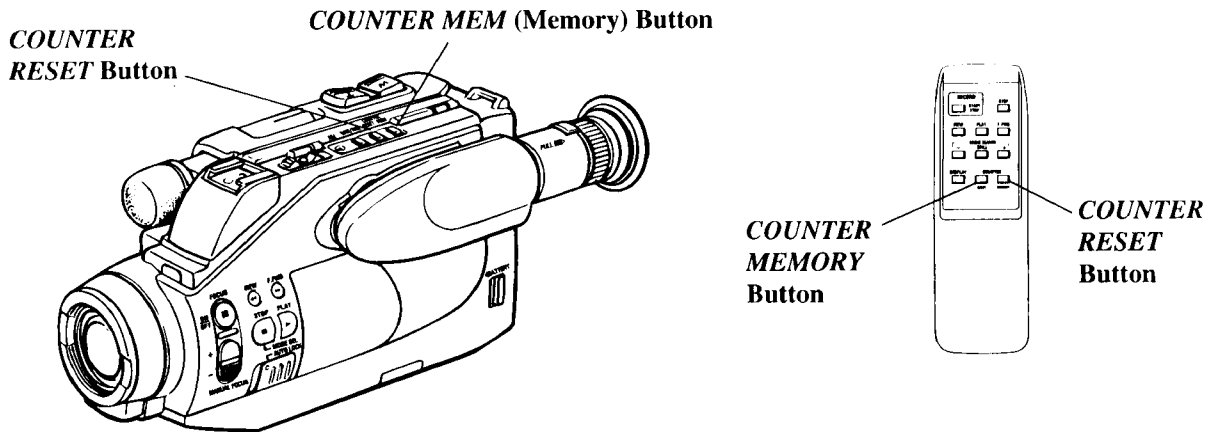

Memory-Stop Feature

The memory-stop feature helps you locate a certain point on the tape. When memory stop is turned on, the tape will stop automatically during rewind or fast forward when the time counter reaches "M 0:00:00".

1. Press the *COUNTER MEM* (memory) button to turn on the memory-stop feature. An "M" appears in front of the time counter.

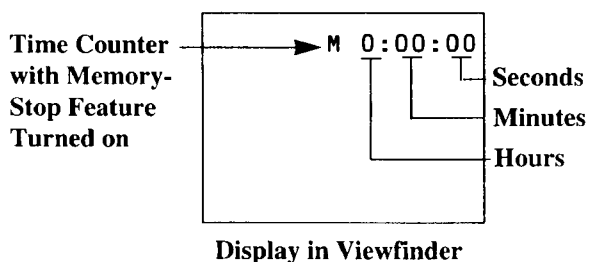

2. Locate the place on the tape you want to return to and press the *COUNTER RESET* button to set the time counter to "M 0:00:00".
3. Continue to record or play the tape. When you want to return to the place you marked, press the thumb trigger to stop recording or the *STOP* button to stop playing back the tape.

4. Make sure the *POWER* switch is in the *PLAY* position, and then press the *REW* (rewind) button. The tape will rewind to the time counter reading of "M 0:00:00".

Notes: The corresponding buttons on the remote control can be used to operate the camcorder.

If you rewind the tape farther back than a counter reading of "0:00:00", a minus will appear in front of the counter.

Camcorder Recording Tips

- Make a video recording of your home and contents to store in a safe place in case of fire or theft.
- Practice recording under a variety of lighting conditions. This will help you respond quickly.
- Do not move the camcorder rapidly from side-to-side while recording. A steady, gradual “pan” avoids blurring and “jitter”.
- Use the viewfinder to make sure the camcorder is level while recording or the scenes will appear “tilted”.
- Do not bump or tap the camcorder’s microphone while recording because this sound will be recorded.
- Be aware of video and audio backgrounds. Background details barely noticed while you are taping may show up as visual “clutter”. Background noises (especially TV sets, radios, household appliances, traffic sounds, etc.) can detract from the sound you want to record.
- Check the focus before you start recording. Use your camcorder’s zoom to help you focus manually. Zoom in on your subject and adjust the focus until you see a clear image in the viewfinder. Then zoom back to where you want to record. If the subject-to-camcorder distance does not change, the subject will remain in sharp focus over the entire zoom range.
- Avoid long “still” shots of landmarks and scenic attractions. Recordings are more interesting if they include people and details. “Local color” gives travel videos lasting appeal. Consider recording a familiar or landmark scene from an unfamiliar vantage point for added interest. Check the lighting before starting to record.
- Try to make sure indoor scenes are well-lit. This improves picture quality and color reproduction.
- Include close-up shots of individuals when taping family outings or group functions.

Holding The Camcorder

- To film at different angles, raise the viewfinder 90°.
- Standing against a wall may give your recordings more stability.
- Use an optional tripod or monopod for stable images.
- Hold the camcorder horizontally. Keep your feet slightly apart and upper arms close to your body.
- When possible, rest your elbows on a table or other stable surface to help keep the camcorder steady.

Traveling Tips

- Write down your camcorder’s serial number and keep it separate from the camcorder when traveling. If your camcorder is lost or stolen, you will be able to identify it.
- Use extra care to avoid damage to your camcorder and accessories when operating them at a beach or pool. Spray, sand, and dust should be avoided. If your lens has been exposed to the elements, clean it only with proper lens cleaning supplies.
- Carry your camcorder in a carrying case when traveling. *See page 4* for a case especially designed for this camcorder. An ordinary suitcase or carry bag does not offer the protection your camcorder needs. Treat your camcorder as carry-on luggage to protect it from rough handling.
- Make sure you have any plug adapters you may need before taking your camcorder to other countries. Consult your RCA dealer for advice.

Care and Maintenance

Camcorder Care and Storage

- Keep dust and grit from entering the camcorder's cassette door. They are abrasive and cause excessive wear both to the camcorder's recording/playback heads and cassettes.
- Always replace the lens cap on the lens when the camcorder is not in use.
- When the camcorder is not in use, always remove the cassette and AC adapter/charger or battery.
- The camcorder can be damaged by improper storage or handling. Do not subject the camcorder to swinging, shaking, or dropping.
- Do not touch the lens with your fingers. The oil from your skin can damage the lens. Always use lens-cleaning tissue and commercially prepared cleaning solution designed for use on camera lens. Improper cleaning may scratch the lens.
- Before handling your camcorder, make sure your hands and face are free from any chemical products such as suntan lotion, as it may damage the finish.
- Do not operate the camcorder for extended periods in temperatures below 40°F (4°C) or above 95°F (35°C). Do not store the camcorder in temperatures below -22°F (-30°C) or above 149°F (65°C).
- Do not operate the camcorder in extremely humid environments.
- Do not aim your camcorder at the sun or other bright objects.
- Do not leave your camcorder in direct sunlight. Doing so could permanently damage the camcorder's internal parts.

Rechargeable Battery Care and Storage

- Do not operate the battery at temperatures below 14°F (-10°C) or above 95°F (35°C). The battery may be damaged if operated at temperatures above 122°F (50°C). Operation time will decrease at extremely low temperatures.
- Store the battery at normal room temperature.
- The battery should be charged at a temperature of 41°F-95°F (5°C-35°C) to prevent damage.
- After repeated chargings and use, the operation time will gradually decrease. When operation time becomes too short to be useful, it is time to replace the battery.

Cassette Care and Storage

- When you are finished with a cassette, rewind it, remove it from the camcorder, and label it.
- Do not touch or cover the small holes in the cassette or use cassettes with damaged or spliced tape.
- Store cassettes vertically in their protective boxes at normal room temperatures. Excessive heat or cold may damage your cassettes.
- Keep the cassette away from strong magnetic fields such as electric motors and other devices.
- Do not use a cassette if it has been damaged or exposed to moisture.
- Close the safety tab to prevent accidental erasure.

Viewfinder Playback

Viewfinder playback is a way to watch tapes in black and white using the camcorder. To hear the sound on the tape, connect an optional earphone to the earphone () jack.

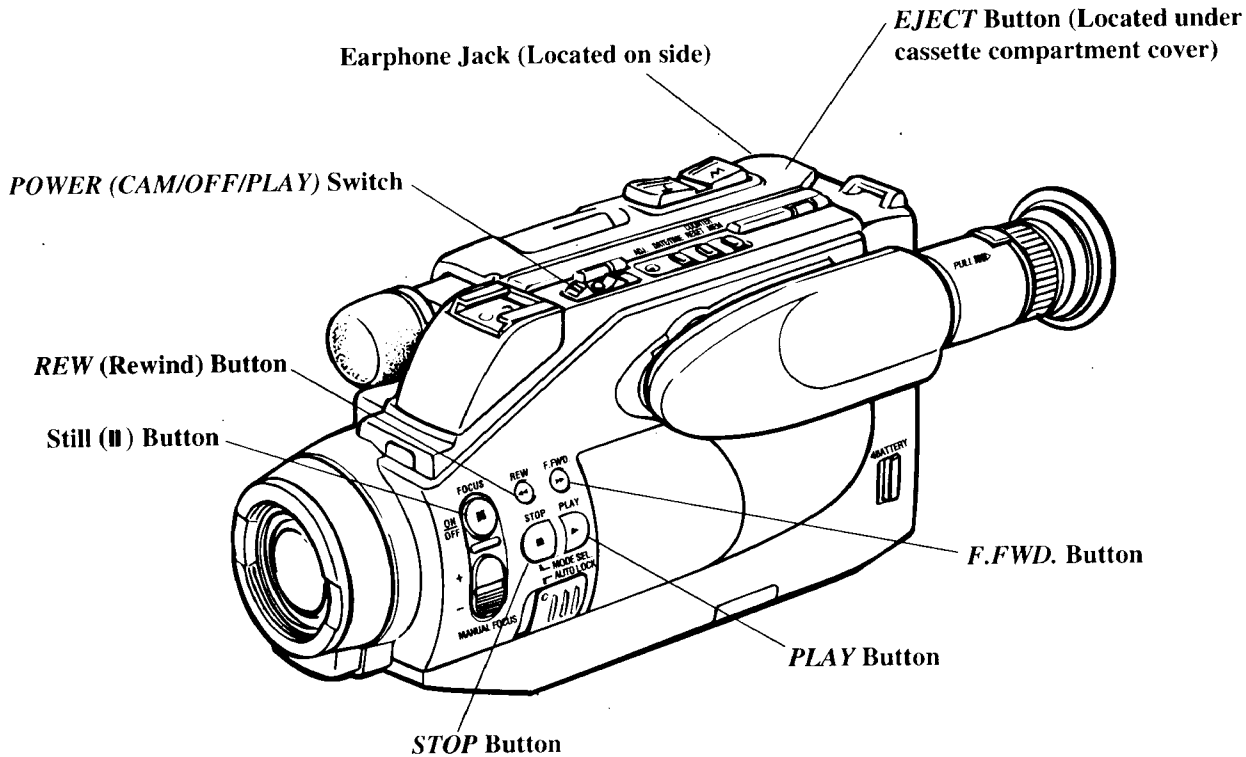

To play back a tape through the viewfinder.

1. Slide the *POWER* switch to *PLAY*.
2. Insert the cassette you want to play back.
3. Press the *PLAY* button.
 - During playback, press the still (II) button to “stop the action” and view one frame of the tape. Press the still (II) button again (or the *PLAY* button) to return to normal playback.
4. Press the *STOP* button when you are finished.
 - During playback, press and hold the *F.FWD.* (fast forward) or *REW* (rewind) button if you want to visually search the tape in forward or reverse. Release the button to return to normal playback.

Caution: Still is designed for momentary interruptions and should not be used for an extended period of time. If the camcorder remains in the still mode for more than five minutes, it will automatically move the tape away from the spinning heads to prevent excessive tape wear.

Notes: The corresponding buttons on the remote control will operate the camcorder.

The camcorder can play back tapes recorded in SP or LP speed. The *LP* indicator appears in the electronic viewfinder when an LP tape is being played.

During still and search operations, it is normal for streaks to appear in the picture.

The sound is muted during special playback operations.

Playback on TV or VCR Using *AUDIO/VIDEO IN* Jacks

To connect your camcorder to a TV or VCR using *AUDIO/VIDEO IN* jacks, use the audio/video cables that were packed with the camcorder. If your TV is already connected to a VCR, you can attach the camcorder to the VCR and watch what the camcorder is recording or playing on the TV.

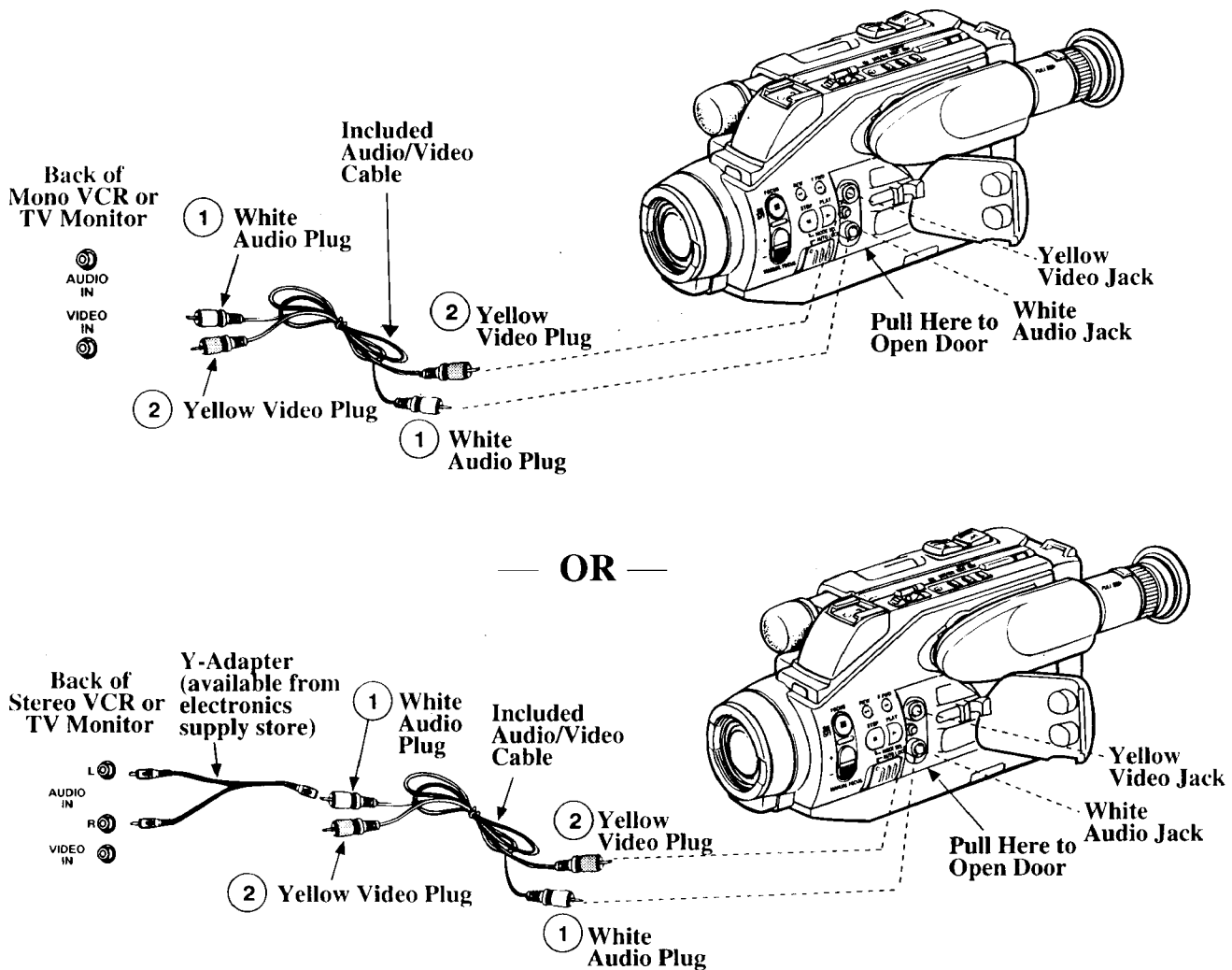

Installation

- ① Attach the white plug on one end of the included audio/video cable to the *AUDIO IN* jack on the TV or VCR and the other white plug to the white audio jack located under the door on the side of the camcorder.
- ② Attach the yellow video plug on one end of the included audio/video cable to the *VIDEO IN* jack on the TV or VCR and the other yellow plug to the yellow video jack located under the door on the side of the camcorder.

Note: If your TV or VCR has stereo *AUDIO* jacks, attach the *AUDIO* plug to the one labeled *MONO*. If one is not labeled *MONO*, you may need a Y-adapter to hear sound from both channels.

Caution: The unauthorized recording of television programs and other recorded material may infringe the rights of others.

Playback on TV or VCR (continued)

Playback Operation and How to Copy Tapes on the VCR

1. A. Camcorder connected directly to TV monitor:
Turn on the TV and tune it to the video input channel.
B. Camcorder connected to VCR that is already connected to TV: Turn on VCR and place it in the "line" or "camera mode". (If your VCR does not have a "line" or "camera mode", consult the VCR owner's manual.) Operate the TV as you normally do to see the signal coming from the VCR.
2. Attach a power supply and slide the camcorder's *POWER* switch to *PLAY*. Insert the cassette you want to playback.
3. Press the *PLAY* button to begin playback.
 - During playback, press the still (II) button to "stop the action" and view one frame of the tape. Press the still (II) button again (or the *PLAY* button) to return to normal playback.

Caution: Still is designed for momentary interruptions, and should not be used for extended time periods. If the camcorder remains in the still mode for more than five minutes, the camcorder will automatically move the tape away from the spinning heads to prevent excessive tape wear.
 - During playback, press and hold the *F.FWD.* (fast forward) or *REW* (rewind) button if you want to visually search the tape in forward or reverse. Release the button to return to normal playback.
4. To copy what the camcorder is playing, place a blank cassette in the VCR, and press the VCR's *RECORD* button.
5. Press the *STOP* button when you are finished.

Notes: The corresponding buttons on the remote control can be used to operate the camcorder.

The camcorder can play back tapes recorded in SP or LP speed. The *LP* indicator appears in the viewfinder when an LP tape is played.

During still and search operations, it is normal for streaks to appear in the picture.

The sound is muted during special playback operations.

Viewing What the Camcorder is Seeing (or Recording)

1. A. Camcorder connected directly to TV: Turn on the TV, and tune it to the video input channel.
B. Camcorder connected to VCR that is already connected to TV: Turn on VCR and place it in the "line" or "camera mode". (If your VCR does not have a "line" or "camera mode", consult the VCR owner's manual.) Operate the TV as you normally do to see the signal coming from the VCR.
2. Attach a power supply and slide the camcorder's *POWER* switch to *CAM*. Place the *ON/POWER SAVE* lever in *ON*, and insert the cassette you want to record on.
Note: When the camcorder is used as a camera, turn the TV's volume down to prevent a high-pitched squeal caused by feedback.
3. Press the camcorder's thumb trigger (or the remote control's *RECORD START/STOP* button) to begin recording. You can watch what the camcorder is seeing (or recording) on the TV screen.

See the Camcorder's displays on the TV.

- Press the *DISPLAY* button on the remote control to see the viewfinder displays on the TV screen.
- Press the *DISPLAY* button again to remove the displays.

Playback on a TV without Audio/Video Inputs

To connect your camcorder to a TV without audio and video inputs, you need an optional CRF800 RF output adapter and coaxial RF cable as shown.

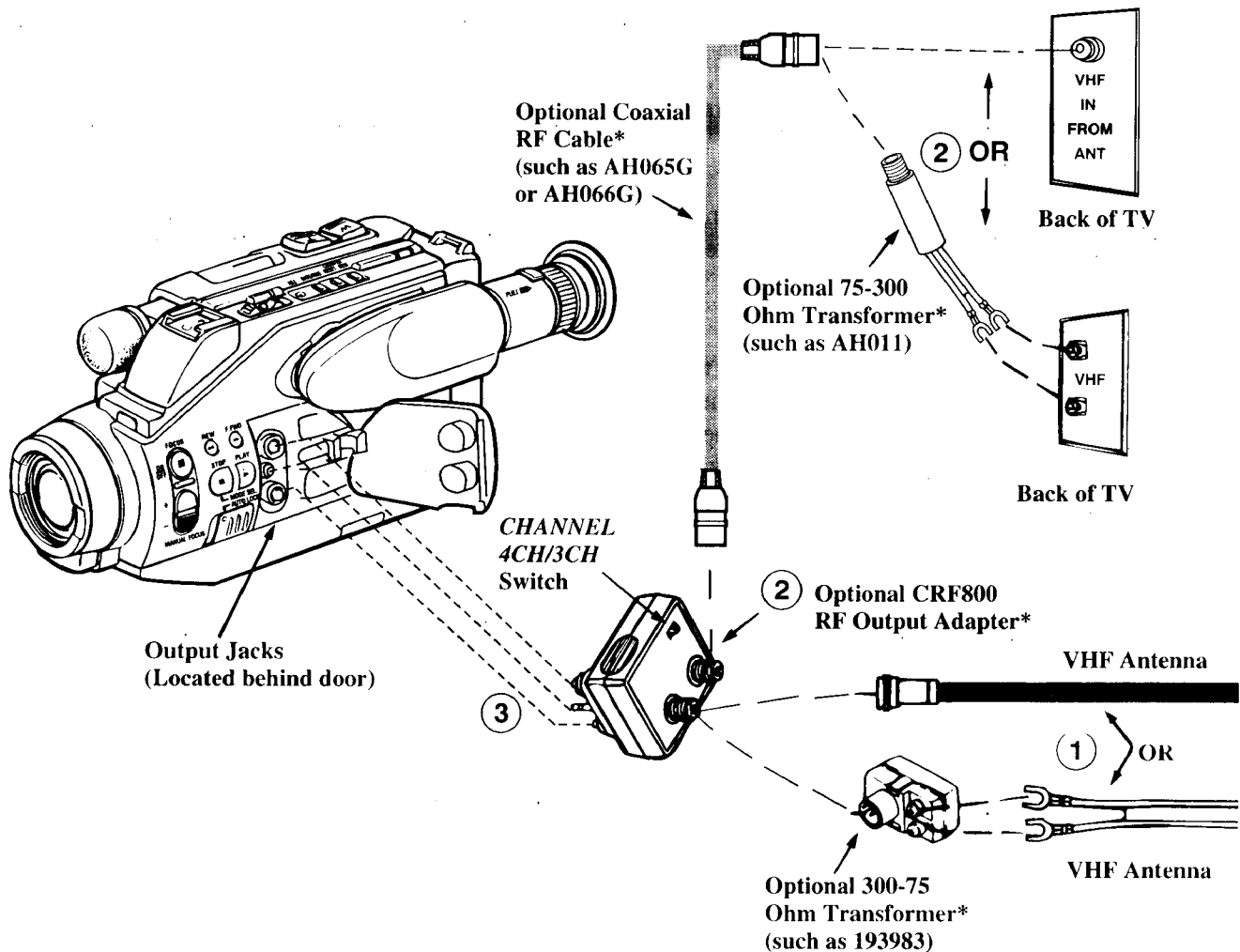

Installation

- ① Disconnect the VHF antenna from your TV. Connect the antenna to the *VHF IN* connector on the optional CRF800 RF output adapter if you leave the adapter connected to the TV.
Note: If your VHF antenna is the flat twin-lead type attached by two screws, you will need an optional 300-75 ohm transformer, such as 193983.
- ② Attach one end of the coaxial RF cable to the *VHF OUT* connector on the RF output adapter and the other end to the VHF input on your TV.
Note: If your TV has screw terminals, you may need an optional 75-300 ohm transformer, such as AH011.
- ③ Attach the RF output adapter's plug to the output jacks located behind the door on the side of the camcorder.

*Optional accessories are available from your dealer or electronics supply store. *Mail order form is on page 5.*

Playback on a TV without Audio/Video Inputs (continued)

Playback Operation

1. Set the *CHANNEL 4CH/3CH* switch on the RF output adapter to *4CH* or *3CH*.
 2. Turn on the TV, and tune it to channel 3 or 4.
 3. Attach a power supply, and slide the camcorder's *POWER* switch to *PLAY*. Insert the cassette you want to play back.
 4. Press the *PLAY* button to begin playback.
 - During playback, press the still (II) button to "stop the action" and view one frame of the tape. Press the still (II) button again (or the *PLAY* button) to return to normal playback.
- Caution:** Still is designed for momentary interruptions, and should not be used for extended time periods. If the camcorder remains in the still mode for more than five minutes, the camcorder will automatically move the tape away from the spinning heads to prevent excessive tape wear.
- During playback, press and hold the *F.FWD.* (fast forward) or *REW* (rewind) button if you want to visually search the tape in forward or reverse. Release the button to return to normal playback.
5. Press the *STOP* button when you are finished.

Notes: The corresponding buttons on the remote control can be used to operate the camcorder.

The camcorder can play back tapes recorded in SP or LP speed. The *LP* indicator appears in the viewfinder when an LP tape is played.

During still and search operations, it is normal for streaks to appear in the picture.

The sound is muted during special playback operations.

Viewing What the Camcorder Is Recording

1. Turn on the TV and tune it to channel 3 or 4.

Note: When the camcorder is used as a camera, turn the TV's volume down to prevent a high-pitched squeal caused by feedback.
2. Set the *CHANNEL* switch on the RF output adapter to the same channel you selected on the TV.
3. Attach a power supply and slide the camcorder's *POWER* switch to *CAM*. Insert the cassette you want to record on. Make sure the *ON/POWER SAVE* lever is *ON*. Press the thumb trigger on the camcorder (or the *RECORD START/STOP* button on the remote control) to start recording. You can watch what you are recording on the TV screen.

See the Camcorder's displays on the TV.

- Press the *DISPLAY* button on the remote control to see the viewfinder displays on the TV screen.
- Press the *DISPLAY* button again to remove the displays.

Normal TV Viewing

You can leave the RF output adapter hooked up to the TV. Disconnect the adapter's plug from the camcorder or turn off the camcorder's power.



Note to Cable TV Installer

This reminder is provided to call your attention to Article 820-40 of the National Electrical Code (Section 54 of Canadian Electrical Code, Part I), that provides guidelines for proper grounding and, in particular, specifies that the cable ground shall be connected to the grounding system of the building as close to the point of cable entry as practical.

Trouble Checks

Troubles sometimes are caused by simple "faults" that you can easily correct without the help of a service technician by first checking a few basic remedies.

Before you call or take your camcorder to an Authorized RCA Compact Camcorder Servicenter, look below for the type of trouble you are experiencing. Then perform the simple checks and adjustments listed for that trouble.

Trouble	Checks and Adjustments
No power	<ul style="list-style-type: none"> • <i>ON/POWER SAVE</i> lever in <i>POWER SAVE</i> position. Place lever in <i>ON</i> position. • If using battery, it may need to be recharged. • If using AC adapter/charger, make sure it is plugged into a working outlet.
Won't record or playback	<ul style="list-style-type: none"> • If using AC adapter/charger, make sure it is plugged into a working outlet. • If dew indicator () appears in the viewfinder, there is moisture in the camcorder. Remove the cassette from the camcorder and let it dry naturally. • There may be no cassette in the camcorder. • Try ejecting and re-inserting the cassette. • The cassette tape may be broken, try another cassette. • You may have reached the end of the cassette, try rewinding it.
Won't playback	<ul style="list-style-type: none"> • <i>POWER</i> switch must be in <i>PLAY</i> position.
Won't record	<ul style="list-style-type: none"> • Safety tab has been closed. (See page 20.) • <i>POWER</i> switch must be in <i>CAM</i> (camera) position. • <i>ON/POWER SAVE</i> lever must be in <i>ON</i> position.
No picture in viewfinder	<ul style="list-style-type: none"> • Remove lens cap. • <i>ON/POWER SAVE</i> lever must be in <i>ON</i> position when <i>POWER</i> switch is in <i>CAM</i> (camera) position.
Tape stops during rewind or fast forward	<ul style="list-style-type: none"> • Time-counter memory may be on. Whenever an "M" appears with the time-counter display, the camcorder will stop rewinding (or fast forwarding) when counter reads "M 0:00:00". Press the <i>REW</i> or <i>F.FWD.</i> button again to continue rewinding or fast forwarding, or press <i>COUNTER MEM</i> (memory) button to turn off memory-stop feature.
Camcorder remains in "stop action" (play-pause) mode	<ul style="list-style-type: none"> • Press the still () (or <i>PLAY</i>) button to return to normal playback.

Trouble Checks (continued)

Trouble	Checks and Adjustments
Poor auto-focus operation	<ul style="list-style-type: none"> • Make sure <i>AUTO LOCK</i> switch is in the <i>AUTO LOCK</i> position. • Scene is dark. Auto-focus may not work under this condition. <i>See page 26 for details on manual focus.</i> • Lens is smudged, and image appears unfocused. • Viewfinder eyepiece focus is misadjusted. (<i>See page 23.</i>)
Picture is too dark or subject too dark.	<ul style="list-style-type: none"> • Select the best preset program mode for the recording situation. <i>See page 27.</i>
Viewfinder displays are out of focus	<ul style="list-style-type: none"> • Try adjusting eyepiece focus control. <i>See page 23.</i> • Pull electronic viewfinder out to the extended operating position.
Date and/time (or date) were recorded on tape	<ul style="list-style-type: none"> • Date and time or date will be recorded on tape whenever they appear in the viewfinder. • Press <i>DATE/TIME</i> button to remove them from viewfinder when recording.
Date and/or time are incorrect	<ul style="list-style-type: none"> • Clock cell may need replacing. <i>See page 22.</i> • Date and/or time may need to be set. <i>See page 22.</i>
Remote control will not operate camcorder	<ul style="list-style-type: none"> • Aim remote control at remote control sensor on camcorder. • Remote control batteries may need replacing. • If <i>POWER</i> switch is in <i>CAM</i> position, the <i>ON/POWER SAVE</i> lever must be in <i>ON</i> position for camcorder to operate. • <i>POWER</i> switch must be in <i>CAM</i> or <i>PLAY</i> position for camcorder to operate. • Camcorder's remote control sensor is exposed to direct sunlight or strong artificial light. This may interfere with operation of camcorder by remote control.

Design Specifications

General

Power requirement: 6VDC
Power consumption: 5.2 W
Weight: 1.7 lbs. (780g)
Dimensions: 4-3/5"(W) x 4-3/5"(H) x 10-1/5"(L)
(117 x 120 x 259mm)

Video Recorder Section

Format: 8mm
Record/Playback System:
Two video record/playback heads
One flying erase head
Headwheel Cylinder Diameter: 40 mm
Video Signal: EIA Standard NTSC Color

Camera Section

Scanning: 525 Lines/60 Fields/30 Frames
Image Sensor: 1/3" high-resolution,
solid-state CCD Imager
Tripod Mount: One 1/4" threaded hole
Lens: f1.8
8:1 (6-48mm)
Diameter: 37 mm
Earphone Jack: Monaural 8 ohm mini jack

This digital apparatus does not exceed the class B limits for radio noise emissions from digital apparatus set out in the Radio Interference Regulations of the Canadian Department of Communications.

L'interférence radioélectrique générée par cet appareil digital ne dépasse pas les limites de la classe B édictées par le Règlement sur les perturbations radioélectriques du Ministère Canadien des Communications.

All features and specifications are subject to change without notice.

This equipment has been tested and found to comply with the limits for a Class B digital device, pursuant to Part 15 of the FCC Rules. These limits are designed to provide reasonable protection against harmful interference in a residential installation. This equipment generates, uses, and can radiate radio frequency energy and, if not installed and used in accordance with the instructions, may cause harmful interference to radio communications. However, there is no guarantee that interference will not occur in a particular installation. If this equipment does cause harmful interference to radio or television reception, which can be determined by turning the equipment off and on, the user is encouraged to try to correct the interference by one or more of the following measures:

- Reorient or relocate the receiving antenna.
- Increase the separation between the equipment and receiver.

- Connect the equipment into an outlet on a circuit different from that to which the receiver is connected.
- Consult the dealer or an experienced radio/TV technician for help.

This device complies with Part 15 of the FCC Rules. Operation is subject to the following two conditions: (1) This device may not cause harmful interference, and (2) this device must accept any interference received, including interference that may cause undesired operation.

Changes or modifications not expressly approved by Thomson Consumer Electronics, Inc. may void the user's authority to operate this camcorder.

Compact Camcorder Limited Warranty

What your warranty covers:

- Any defect in material or workmanship.
- 90 days for labor charges.
- One year for parts.

The warranty period for rental units begins with the first rental.

What we will do:

- Pay any Authorized RCA Compact Camcorder Servicenter the labor charges to repair your camcorder.
- Pay any Authorized RCA Compact Camcorder Servicenter for the new or, at our option, rebuilt replacement parts required to repair your camcorder.

How you get service:

- Check with your RCA Dealer or call 1-800-336-1900 for the Authorized RCA Compact Camcorder Servicenter nearest you. State that you have an RCA 8 millimeter camcorder.

If an Authorized RCA Compact Camcorder Servicenter is conveniently near you:

- Take your camcorder to the Authorized RCA Compact Camcorder Servicenter of your choice.
- Show the Servicenter Representative your sales receipt or other evidence of purchase date.
- Pick up your camcorder when repairs are completed.

If an Authorized RCA Compact Camcorder Servicenter is not located conveniently near you:

- Pack the camcorder so that it will not be damaged during shipping. (We recommend using the original carton and packing materials.) Include any cables and other accessories originally furnished with the camcorder.
- Include in the camcorder carton (1) a copy of your sales receipt or other evidence of purchase date, (2) your name and address, and (3) a brief description of the problem.
- Ship the camcorder to an Authorized RCA Compact Camcorder Servicenter.
- Pay any charges billed to you by the Servicenter for service not covered by the warranty.

What your warranty *does not* cover:

- Customer instruction. (Your owner's manual clearly describes how to install, adjust, and operate your camcorder. Any additional information should be obtained from your Dealer.)
- Installation and related adjustments.
- Cleaning of video/audio heads.
- Damage from misuse or neglect.
- Batteries for clock or other features.
- A camcorder that has been modified or incorporated into other products or is used for institutional or other commercial purposes.
- A camcorder purchased or serviced outside the USA.

How state law relates to this warranty:

- This warranty gives you specific legal rights, and you also may have other rights that vary from state to state.

Product registration:

- Please complete and mail the *product registration card* packed with your camcorder. It will make it easier to contact you should it ever be necessary. The return of the card is not required for warranty coverage.

If you purchased your camcorder in Canada:

- The Canadian warranty applies in place of this warranty.

Index

- Accessories, Included8
- Accessories, Optional4-7
- Accessory Shoe.....12
- Accessory, Order Form.....5-6
- Adapter/Charger, Safety
 - InstructionsInside Front Cover
- Adapter/Charger, Using16
- ADJ. (Adjust) Button13,22
- Attaching the Shoulder Strap.....9
- AUTO LOCK Switch.....11,12,21,26,27
- Auto Focus26
- Auto High-Speed Shutter Mode.....27
- Auto Mode27
- Batteries, Remote Control.....14
- BATTERY Eject Lever.....12,18
- Battery Safety Precautions18
- Battery Warning.....18,24
- Battery, Care and Storage30
- Battery, Using Rechargeable17-18
- CAM/OFF/PLAY POWER Switch.....11-12
- Camcorder, Powering16-19
- Camcorder, Turning On.....11
- Camcorder, Unpacking8
- Car Cord, Optional.....19
- Care and Maintenance.....30
- Care and Storage of the Battery30
- Cassette Care and Storage.....30
- Cassette Compartment10,13,20
- Cassettes, Inserting and Removing10,20
- Charging the Battery17
- Cleaning the Viewfinder23
- Clock Cell Compartment12,22
- Close-Up Mode.....27
- Compact Camcorder Limited Warranty.....39
- Connection, TV with AUDIO/VIDEO
 - Jacks.....32-33
- Connection, TV without Audio/Video
 - Inputs34-35
- Contents.....Front Cover
- Copying Tapes.....32-33
- COUNTER MEM (Memory) Button.....13,24-25,28
- COUNTER MEMORY Button14-15,24-25,28
- COUNTER RESET Button13,14-15,24-25,28
- Date and Time Display22,24-25
- Date and Time, Recording22
- Date and Time, Setting22
- DATE/TIME Button13,22,25
- DC IN 6.5V Jack13,16,19
- DC Power Cord.....8,16
- Design Specifications.....38
- Dew Indicator.....11,24
- DISPLAY Button.....14-15,33,35
- Displays in Viewfinder24-25
- Earphone Jack11,13,21,31
- EJECT Button10,13,20
- Electronic Viewfinder, Adjusting23
- Erase Protection20
- Eyepiece Focus Control11,12,23
- F.FWD. (Fast Forward)
 - Button12,14-15,21,31,33,35
- FF Display24
- First-Time Operation8-13
- Flickerless Mode27
- Flying Erase Head.....21
- FOCUS ON/OFF Button12,25,26
- Focusing Your Camcorder.....26
- Hand Strap10,13
- Important Safeguards.....2-3
- Important Safety InstructionsInside Front Cover
- Inserting and Removing Cassettes20
- Lens.....12,30
- Lens Cap10,13
- Limited Warranty39
- Low Level Battery Warning18
- Low Light Mode27
- LP Tape Speed Display.....24
- Maintenance and Care.....30
- Making Better Videos.....29
- MANUAL FOCUS + and - Button12,24-25,26
- Manual Focus (MF, MF+, and MF-)
 - Indicators24-25,26
- Memory Stop Indicator.....24-25,28
- Memory-Stop Feature28
- Microphone12,21
- MODE SEL. Button12,24,27
- ON/POWER SAVE Lever.....11,13,17
- OPEN Button10,13,20
- Operation, First-Time8-13
- Optional Accessories4-7
- Optional Car Cord.....19

Index (continued)



Order Form, Accessory.....	5-6	Setting the Time and Date.....	22
Output Jacks (Yellow Video, DC, and White Audio).....	12,32,34	Shoulder Strap Rings.....	9,13
<i>PAUSE</i> Display.....	24	Shoulder Strap, Attaching.....	9
<i>PLAY</i> Button.....	12,14-15,24,31,33,35	Solving Problems.....	36-37
<i>PLAY</i> Display.....	24	SP Speed.....	20
Playback.....	31-35	Special Features.....	21
Playback on a TV with <i>AUDIO/VIDEO IN</i> Jacks.....	32-33	Specifications.....	38
Playback on a TV without Audio/Video Inputs.....	34-35	Sports Mode.....	27
Playback, First.....	12	Status Displays.....	24
Playback, Viewfinder.....	31	Still (II) Button	12,31,33,35
Positioning the Tape.....	21	<i>STILL</i> Button.....	14-15,31,33,35
<i>POWER CAM/OFF/PLAY</i> Switch.....	11,12	<i>STOP</i> Button.....	12,14-15,21,31,33,35
<i>POWER SAVE/ON</i> Lever.....	11,13,17	<i>STOP</i> Display.....	24
Power Zooming.....	25	Storage.....	30
Powering the Camcorder.....	16-19	<i>T</i> (Telephoto) Zoom Button.....	25
Preset Program Indicators.....	24,27	Table of Contents.....	Front Cover
Preset Program Modes.....	24,27	Tally Light.....	11,12,15,21
Problem Solving.....	36-37	<i>TAPE END</i> Indicator.....	24
Product Registration.....	Inside Front Cover	<i>TAPE</i> Indicator.....	24
Program Preset Modes.....	24,27	Tape Copying.....	32-33
Quick Review.....	21	Tape Positioning.....	21
RCA Video Cassettes.....	20,30	Things to Avoid.....	29-30
<i>REC</i> Display.....	24	Thumb Trigger.....	11,13
<i>REC START/STOP</i> Button (Thumb Trigger).....	11,13	Tilt Adjustment, Viewfinder.....	23
<i>RECORD START/STOP</i> Button.....	14-15	Time and Date Display.....	22
Recording Speed and Times.....	20	Time and Date, Recording.....	22
Recording Steps, First-Time.....	8-13	Time and Date, Setting.....	22
Recording Tips.....	29	Time Counter Display.....	24-25,28
Recording, First.....	11	Time Counter with Memory Stop Feature.....	28
Refreshing the Battery.....	17	Tips, Recording.....	29
Registration Card.....	Inside Front Cover	Tips, Traveling.....	29
Remote Control.....	14-15	Tripod, Using.....	7
Review, Quick.....	21	Trouble Checks.....	36-37
<i>REW</i> (Rewind) Button.....	12,14-15,21,31,33,35	Turning On the Camcorder.....	10
<i>REW</i> Display.....	24	Unpacking the Camcorder.....	11
Safeguards, Important.....	2-3	Video Cassettes.....	20,30
Safety Tab.....	20	Viewfinder.....	11,12,23,24-25,31
Safety Instructions for AC Adapter/Charger.....	Inside Front Cover	Viewfinder Displays.....	24-25
Safety Instructions.....	Inside Front Cover	Viewfinder Playback.....	31
Safety Precautions.....	1	Viewfinder, Cleaning.....	23
<i>SCENE SEARCH</i> + and - Buttons.....	14-15,21	<i>W</i> (Wide Angle) Zoom Button.....	25
		Warranty.....	39
		Zooming, Power.....	25

RCA

For your nearest Home
Entertainment Dealer
or Authorized Servicer
call toll-free in the U.S.A.

1-800-336-1900

Thomson Consumer Electronics
600 N Sherman Dr, PO Box 1976
Indianapolis, IN 46206

©1993 Thomson Consumer Electronics, Inc.

Trademark(s)® Registered

Marca(s) Registrada(s)

Printed in Japan

Part Number 93-Pro808-1

1AG6P1P0046--

