

Operating Guide & Warranty

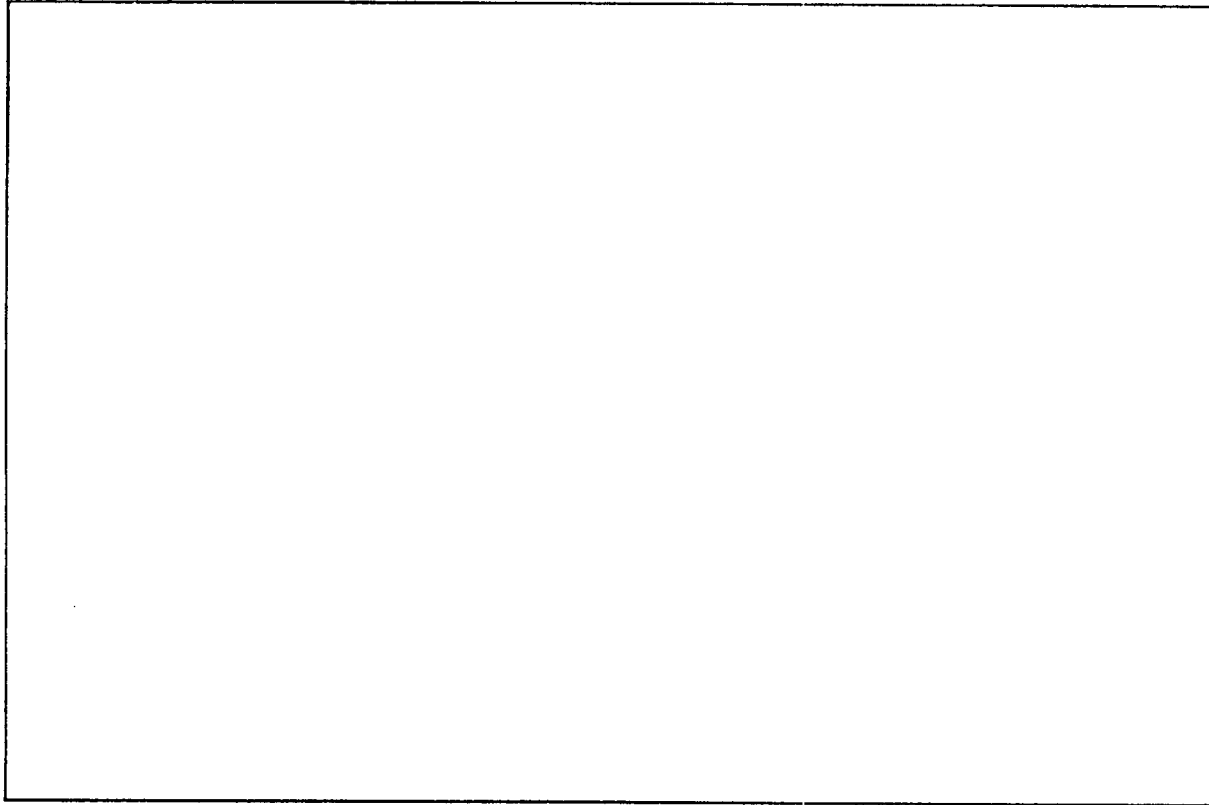

*File,
Small Folder*

13" Color TV/VCR Combination

SRV1304S

WARNING:

TO REDUCE THE RISK OF FIRE OR ELECTRIC SHOCK, DO NOT EXPOSE THIS APPLIANCE TO RAIN OR MOISTURE.



CAUTION

**RISK OF ELECTRIC SHOCK
DO NOT OPEN**



CAUTION: TO REDUCE THE RISK OF ELECTRIC SHOCK, DO NOT REMOVE COVER (OR BACK) NO USER SERVICEABLE PARTS INSIDE. REFER SERVICING TO QUALIFIED SERVICE PERSONNEL.



THIS SYMBOL INDICATES THAT DANGEROUS VOLTAGE CONSTITUTING A RISK OF ELECTRIC SHOCK IS PRESENT WITHIN THIS UNIT.



THIS SYMBOL INDICATES THAT THERE ARE IMPORTANT OPERATING AND MAINTENANCE INSTRUCTIONS IN THE LITERATURE ACCOMPANYING THE APPLIANCE.

The important note is located on the rear of the cabinet.

IMPORTANT SAFEGUARDS

- 1. Read instructions**-All the safety and operating instructions should be read before the appliance is operated.
- 2. Retain Instructions**-The safety and operating instructions should be retained for future reference.
- 3. Heed Warnings**-All warnings on the appliance and in the operating instructions should be adhered to.
- 4. Follow Instructions**-All operating and use instructions should be followed.
- 5. Cleaning**-Unplug TV/VCR from the wall outlet before cleaning. Do not use liquid cleaners or aerosol cleaners. Use a damp cloth for cleaning.
EXCEPTION: A product that is meant for uninterrupted service and, that for some specific reason, such as the possibility of the loss of an authorization code for a CATV converter, is not intended to be unplugged by the user for cleaning or any other purpose, may exclude the reference to unplugging the appliance in the cleaning description otherwise required in item 5.
- 6. Attachments**-Do not use attachments not recommended by the TV/VCR manufacturer as they may cause hazards.
- 7. Water and Moisture**-Do not use this TV/VCR near water-for example, near a bath tub, wash bowl, kitchen sink, or laundry tub, in a wet basement, or near a swimming pool, and the like.
- 8. Accessories**-Do not place this TV/VCR on an unstable cart, stand, tripod, bracket, or table. The TV/VCR may fall, causing serious injury to someone, and serious damage to the appliance. Use only with a cart, stand, tripod, bracket, or table recommended by the manufacturer, or sold with the TV/VCR. Any mounting of the appliance should follow the manufacturer's instructions and should use a mounting accessory recommended by the manufacturer. An appliance and cart combination should be moved with care.

PORTABLE CART WARNING
S3126A
- 9. Ventilation**-Slots and openings in the cabinet and the back or bottom are provided for ventilation and to ensure reliable operation of the TV/VCR and to protect it from overheating. These openings must not be blocked or covered. The openings should never be blocked by placing the TV/VCR on a bed, sofa, rug, or other similar surface. This TV/VCR should never be placed near or over a radiator or heat register. This TV/VCR should not be placed in a built-in installation such as a bookcase or rack unless proper ventilation is provided or the manufacturer's instructions have been adhered to.
- 10. Power Sources**-This TV/VCR should be operated only from the type of power source indicated on the marking label. If you are not sure of the type of power supply to your home, consult your appliance dealer or local power company. For TV/VCRs intended to operate from battery power, or other sources, refer to the operating instructions.
- 11. Grounding or Polarization**-This TV/VCR is equipped with a polarized alternating-current line plug (a plug having one blade wider than the other). This plug will fit into the power outlet only one way. This is a safety feature. If you are unable to insert the plug fully into the outlet, try reversing the plug. If the plug should still fail to fit, contact your electrician to replace your obsolete outlet. Do not defeat the safety purpose of the polarized plug.
- 12. Power-Cord Protection**-Power-supply cords should be routed so that they are not likely to be walked on or pinched by items placed upon or against them, paying particular attention to cords at plugs, convenience receptacles, and the point where they exit from the appliance.

FIGURE A
EXAMPLE OF ANTENNA GROUNDING AS PER
NATIONAL ELECTRICAL CODE

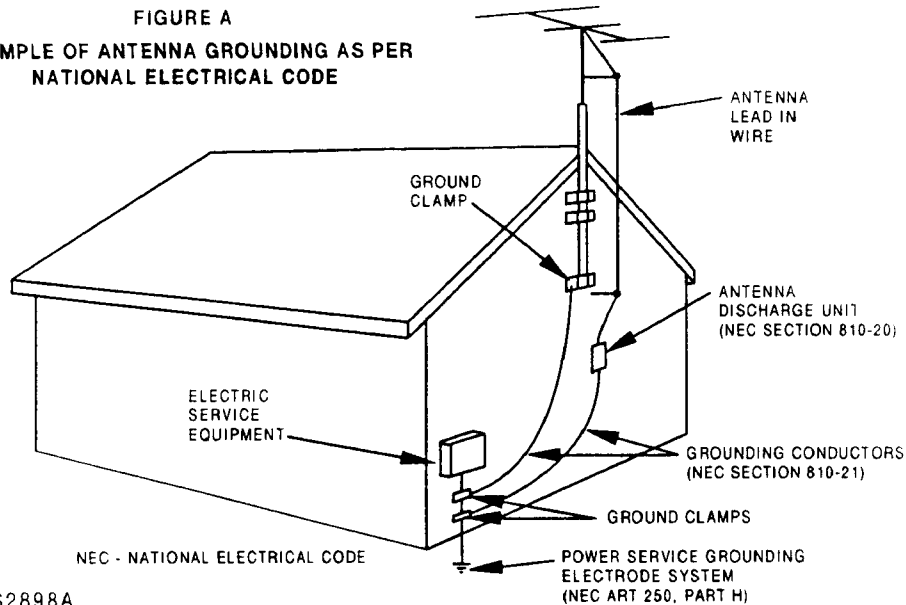

S2898A

15. **Outdoor Antenna grounding**-If an outside antenna or cable system is connected to the TV/VCR, be sure the antenna or cable system is grounded so as to provide some protection against voltage surges and built-up static charges. Article 810 of the National Electrical Code, ANSI/NFPA No. 70, provides information with respect to proper grounding of the mast and supporting structure, grounding of the lead-in wire to an antenna discharge unit, size of grounding conductors, location of antenna-discharge unit, connection to grounding electrodes, and requirements for the grounding electrode. (Fig. A)
14. **Lightning**-For added protection for this TV/VCR receiver during a lightning storm, or when it is left unattended and unused for long periods of time, unplug it from the wall outlet and disconnect the antenna or cable system. This will prevent damage to the TV/VCR due to lightning and power-line surges.
15. **Power Lines**-An outside antenna system should not be located in the vicinity of overhead power lines or other electric light or power circuits, or where it can fall into such power lines or circuits. When installing an outside antenna system, extreme care should be taken to keep from touching such power lines or circuits as contact with them might be fatal.
16. **Overloading**-Do not overload wall outlets and extension cords as this can result in a risk of fire or electric shock.
17. **Object and Liquid Entry**-Never push objects of any kind into this TV/VCR through openings as they may touch dangerous voltage points or short out parts that could result in a fire or electric shock. Never spill liquid of any kind on the TV/VCR.
18. **Servicing**-Do not attempt to service this TV/VCR yourself as opening or removing covers may expose you to dangerous voltage or other hazards. Refer all servicing to qualified service personnel.
19. **Damage Requiring Service**-Unplug this TV/VCR from the wall outlet and refer servicing to qualified service personnel under the following conditions:
 - a. When the power-supply cord or plug is damaged or frayed.
 - b. If liquid has been spilled, or objects have fallen into the TV/VCR.
 - c. If the TV/VCR has been exposed to rain or water.
 - d. If the TV/VCR does not operate normally by following the operating instructions. Adjust only those controls that are covered by the operating instructions, as improper adjustment of other controls may result in damage and will often require extensive work by a qualified technician to restore the TV/VCR to its normal operation.
 - e. If the TV/VCR has been dropped or damaged in any way.
 - f. When the TV/VCR exhibits a distinct change in performance-this indicates a need for service.
20. **Replacement Parts**-When replacement parts are required, be sure the service technician has used replacement parts specified by the manufacturer that have the same characteristics as the original part. Unauthorized substitutions may result in fire, electric shock, injury to persons or other hazards.
21. **Safety Check**-Upon completion of any service or repairs to this TV/VCR, ask the service technician to perform routine safety checks to determine that the TV/VCR is in proper operating condition.
22. **Heat**-This TV/VCR product should be situated away from heat sources such as radiators, heat registers, stoves, or other products (including amplifiers) that produce heat.

TABLE OF CONTENTS

IMPORTANT SAFEGUARDS	2	JOG AND SHUTTLE FUNCTION.....	21
PRECAUTIONS.....	5	SPECIAL PLAYBACK	22
LOCATION	5	RENTAL PLAY.....	22
AVOID THE HAZARDS OF ELECTRICAL SHOCK AND FIRE.....	5	AUTO REPEAT PLAYBACK	22
WARNING	5	COUNTER MEMORY	23
FEATURES	6	SEARCH SELECT	24
SUPPLIED ACCESSORIES.....	6	TIME SEARCH.....	24
VIDEO CASSETTE.....	7	INDEX SEARCH	25
OPERATING CONTROLS AND FUNCTIONS.....	8	VIEWING AND RECORDING THE SAME PROGRAM	26
REMOTE CONTROL OPERATION.....	10	OTR (ONE TOUCH RECORDING).....	27
INSTALLING THE BATTERIES	11	AUTOMATIC TIMER RECORDING.....	28
ANTENNA CONNECTIONS	12	QUICK SET PROGRAM	30
VHF/UHF COMBINED ANTENNA	12	SPECIAL FEATURES	32
VHF/UHF SEPARATE ANTENNAS	12	DEGAUSSING.....	32
CABLE WITHOUT CONVERTER/DESCRAMBLER BOX.....	12	AUTO REWIND-EJECT	32
CABLE WITH CONVERTER/DESCRAMBLER BOX.....	13	TRACKING ADJUSTMENT	32
EXTERNAL INPUT MODE.....	13	TO CHANGE THE LANGUAGE.....	32
TV/CATV CHANNEL MEMORY PROGRAM- MING.....	14	SETTING THE SLEEP TIMER	32
SETTING THE CLOCK	16	SETTING THE ALARM TIMER	33
AUTO CLOCK SETTING	16	TROUBLESHOOTING GUIDE	34
MANUAL CLOCK SETTING	17	MAINTENANCE.....	35
TV OPERATION	18	SERVICING.....	35
GAME MODE.....	18	CABINET CLEANING	35
PICTURE CONTROL.....	18	HEAD CLEANING	35
CLOSED CAPTION SYSTEM	19	SPECIFICATIONS	35
PLAYBACK.....	20	GENERAL SPECIFICATIONS	35
		ELECTRICAL SPECIFICATIONS.....	35
		OTHER SPECIFICATIONS.....	35

→ 36

PRECAUTIONS

LOCATION

For safe operation and satisfactory performance of your unit, keep the following in mind when selecting a place for its installation:

- Shield it from direct sunlight and keep it away from sources of intense heat.
- Avoid dusty or humid places.
- Avoid places with insufficient ventilation for proper heat dissipation. Do not block the ventilation holes at the top and bottom of the unit. Do not place the unit on a carpet because this will block the ventilation holes.
- Install unit in a horizontal position.
- Avoid locations subject to strong vibration.
- Do not place the unit near strong magnetic fields.
- Do not move the unit from a cold to a hot place or vice versa.

AVOID THE HAZARDS OF ELECTRICAL SHOCK AND FIRE

- Do not handle the power cord with wet hands.
- Do not pull on the power cord when disconnecting it from an AC wall outlet. Grasp it by the plug.
- If, by accident, water is spilled on your unit, unplug the power cord immediately and take the unit to an authorized Sears service center for servicing.
- Do not put your fingers or objects into the TV/VCR cassette holder.
- Do not place anything directly on top of the unit.

WARNING

Moisture condensation may occur inside the unit when it is moved from a cold place to a warm place, or after heating a cold room or under conditions of high humidity. If a tape is played in a TV/VCR which has moisture, it may damage the tape and TV/VCR. Therefore when the condensation occurs inside the unit turn the POWER button on and allow at least 2 hours for the unit to dry out.

FCC WARNING- This equipment may generate or use radio frequency energy. Changes or modifications to this equipment may cause harmful interference unless the modifications are expressly approved in the instruction manual. The user could lose the authority to operate this equipment if an unauthorized change or modification is made.

IMPORTANT COPYRIGHT INFORMATION

Unauthorized recording or use of broadcast television programming, video tape, film or other copyrighted material may violate applicable copyright laws. We assume no responsibility for the unauthorized duplication, use or other acts which infringe upon the rights of copyright owners.





The serial number of this product may be found on the back of the unit. No others have the same serial number as yours. You should record the number and other vital information here and retain this book as a permanent record of your purchase to aid identification in case of theft.

Date of Purchase	
Dealer Purchase from	
Dealer Address	
Dealer Phone No.	
Model No.	
Serial No.	

FEATURES

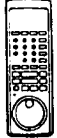
- **4 Rotary Head Record /Playback System**— 4 rotary heads to ensure excellent picture quality and special effects playback.
- **Auto Power On and Off system**— Automatically turns the TV/VCR on as you insert the cassette, turns off and ejects after auto-rewind when the beginning of the tape is reached.
- **On Screen Programming**— All major operating and programming functions appear on your TV/VCR screen for operating convenience.
- **Bilingual on screen menu display selectable in English or Spanish**
- **Auto Clock Setting**— Allows you to use the clock program of the PBS broadcast.
- **Infrared Remote control unit**— Allows you to use most of the controls from a remote location.
- **181 Channel Capability PLL Frequency Synthesizer Tuner with Direct Channel Entry**— (A CATV Box may be necessary to view scrambled CATV channels.)
- **Game Mode**— Allows TV/VCR display to be suitable for use with a TV game.
- **CCS (Closed Caption System)**— You may view specially labeled (cc) TV programs, movies, news, prerecorded tapes, etc. with either a dialogue caption or text display added to the program.
- **Three Different Record/Playback Speed**— Select SP mode (Standard play), LP mode (Long play) and SLP mode (Super long play) for up to eight hours of recording/playback with a T-160 tape.
- **Automatic Playback Speed Selection**— Automatically selects the proper playback speed even if you select a different speed.
- **Visual Search**— Allows you to view a video tape at a high speed in either a forward or reverse direction.
- **STILL**— "Freeze" the picture at any time, for close viewing of a particular scene.
- **Rental Play Mode**— Improves playback picture quality of worn tapes, especially rental tapes.
- **Auto Repeat Playback**— Allows you to repeat a tape indefinitely without using the PLAY button. You can select all feature (that repeat playback from the beginning to the end of the tape) or blank feature (that repeat only recorded part, not blank part).
- **Time Search**— Allows you to set the TV/VCR to advance the tape by entering the desired playback time you want to skip.
- **Index Search**— Allows you to index the start of a recording.
- **Slow Motion**— You can view the video program at a slower than normal playback speed. Slow speed can be controlled by pressing F.FWD button (faster) or REW - button (slower) on the remote control.
- **Jog and Shuttle**— You can adjust the playback speed using the Shuttle Ring (the outer ring) or advance the frame one by one using the Jog Dial (the inner dial).
- **OTR (One Touch Recording)**— Automatic timed recording from 30 to 480 minutes is possible at the push of OTR button. (Timer adjustments for recording are not required.)
- **1 Year, 8 Events Timer (including Today, Daily and Weekly Timer Recording)**— The built-in timer allows you to record up to 7 programs at different times on different channels up to 1 year in advance. The Quick Set Program feature uses program number 8. The daily timer will allow recordings to be made of daily broadcasts and the weekly timer will allow recording to be made once a week up to the end of the tape.
- **Quick Set Program**— Allows you to easily record one program within the next 24 hours.
- **Sleep Timer**— Allows you to turn off the TV/VCR without using the POWER button after a desired time period.
- **Alarm Function**— Allows you to turn on the TV/VCR without using the POWER button at a desired time.

SUPPLIED ACCESSORIES

<p>Remote Control Unit</p>  <p>PART NO. (UREMT33SR001)</p>	<p>2 AA Batteries</p> 	<p>Matching Adapter (300ohm - 75ohm)</p> 	<p>VHF/UHF Dipole Antenna</p> 	<p>• If you need to replace these accessories, please refer to the PART NO. under the illustrations and contact the Sears parts department for ordering.</p>
---	---	--	--	--

VIDEO CASSETTE

This TV/VCR will operate with any cassette that has the VHS mark. For best results we recommend the use of high-quality tapes.

- Do not use poor quality or damaged tapes.

The table below shows the recording/playback time using a T-60, T-120 or T-160 tape in the SP, LP or SLP mode.

MODE	CASSETTE		
	T-60	T-120	T-160
SP Mode	1 hour	2 hours	2-2/3 hours
LP Mode	2 hours	4 hours	5-1/3 hours
SLP Mode	3 hours	6 hours	8 hours

When handling video tapes, take the following precautions:

- Avoid moisture, which can condense on the tape if it is moved from a cold place to a warm place. Playing a tape that has moisture in it will damage the tape and your TV/VCR. Before using a tape with these conditions, wait until the tape has warmed to room temperature and the moisture has evaporated.
- Avoid extreme heat, high humidity and magnetic fields.
- Do not tamper with the cassette mechanism.
- Do not touch the tape with your fingers.

ERASE PREVENTION

You may prevent accidental erasing of a tape by breaking off the tab on the back edge of the cassette. If you decide to record on the tape again, cover the hole with transparent tape.

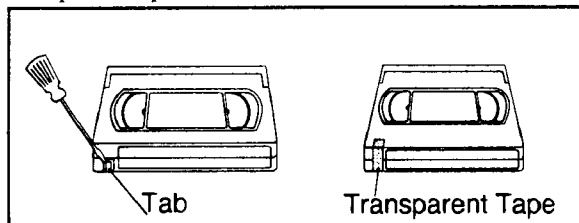

INSERTING A CASSETTE

Insert the cassette in the direction as shown. Push in gently, but continuously, on the center-back of the cassette until it is drawn completely into the TV/VCR.

The TV/VCR will automatically turn on when the cassette is properly inserted.

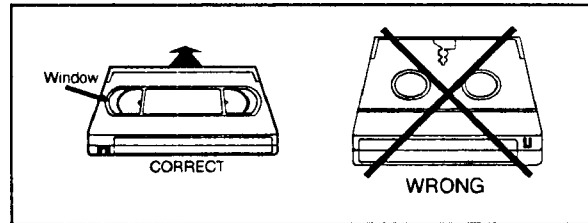

REMOVING A CASSETTE

1

Press STOP/EJECT button on the TV/VCR in the stop mode.

2

When the cassette stops moving, pull the cassette out of the cassette compartment and store it properly.

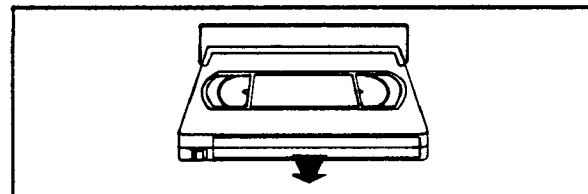

3

Store the cassette in its case as shown.

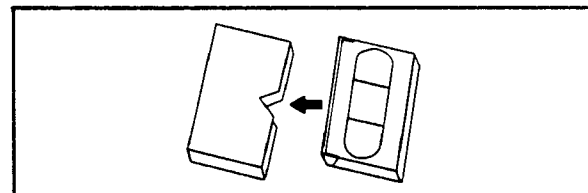

OPERATING CONTROLS AND FUNCTIONS

— FRONT VIEW —

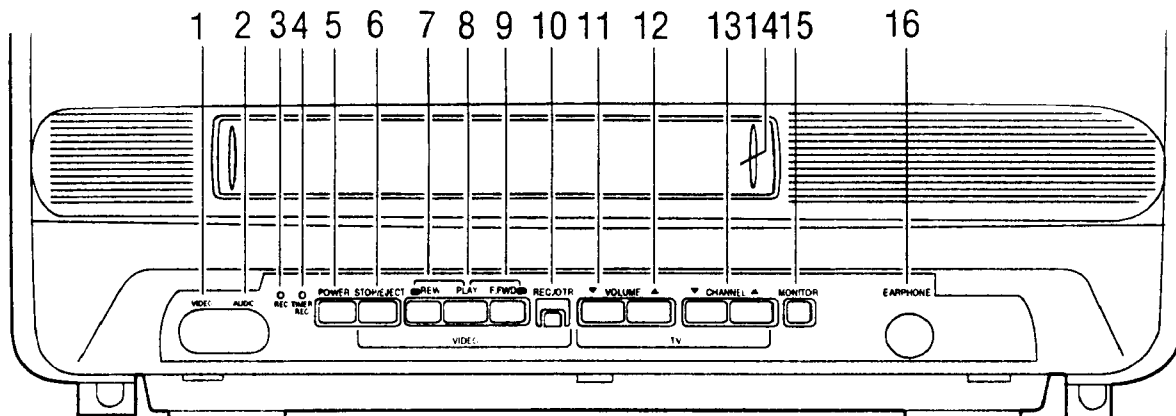

- 1 **VIDEO IN jack**— For connection to video output jack of your video camera or another VCR.
- 2 **AUDIO IN jack**— For connection to audio output jack of your audio equipment or another VCR.
- 3 **REC indicator**— Lights up when recording.
- 4 **TIMER REC indicator**— Lights up in the Timer Recording mode.
- 5 **POWER button**— Press to turn TV/VCR on and off. Press to activate the automatic timer recording.
- 6 **STOP/EJECT button**— Press to stop tape motion. Press again to remove tape from TV/VCR.
- 7 **REW button**— Press to rewind tape, or to view video in reverse during the Play mode at a faster than normal speed. Press PLAY button to return TV/VCR to normal playback speed.
- 8 **PLAY button**— Press to begin playback of a tape.
- 9 **F.FWD button**— Press to advance tape, or to view video in forward during Play mode at a faster than normal speed. Press PLAY button to return TV/VCR to normal playback speed.
- 10 **REC/OTR button**— Press to begin manual recording. Press again to activate One Touch Recording.
- 11 **VOLUME ▼ button**— Press to decrease the volume level.
DELETE function— Press to cancel Quick Set Program.
- 12 **VOLUME ▲ button**— Press to increase the volume level.
SELECT function— Press to select the next step when setting Quick Set Program.
- 13 **CHANNEL ▲/▼ buttons**— Press to select the channel for viewing or recording.
TRACKING +/- function— Press to minimize video 'noise' (lines or dots on screen) during the Play mode.
SET function— Press to adjust time using ▼ or ▲ button in the Quick Set Program.
- 14 **Cassette Compartment**
- 15 **MONITOR button**— Press to turn the TV/VCR screen on and off when in the Recording mode.
Quick Set Program function— Press to set Quick Set Program.
- 16 **EARPHONE jack**— For connection to earphone (not supplied) for personal listening. The size of jack is 1/8" monaural (3.5mm).

— REAR VIEW —

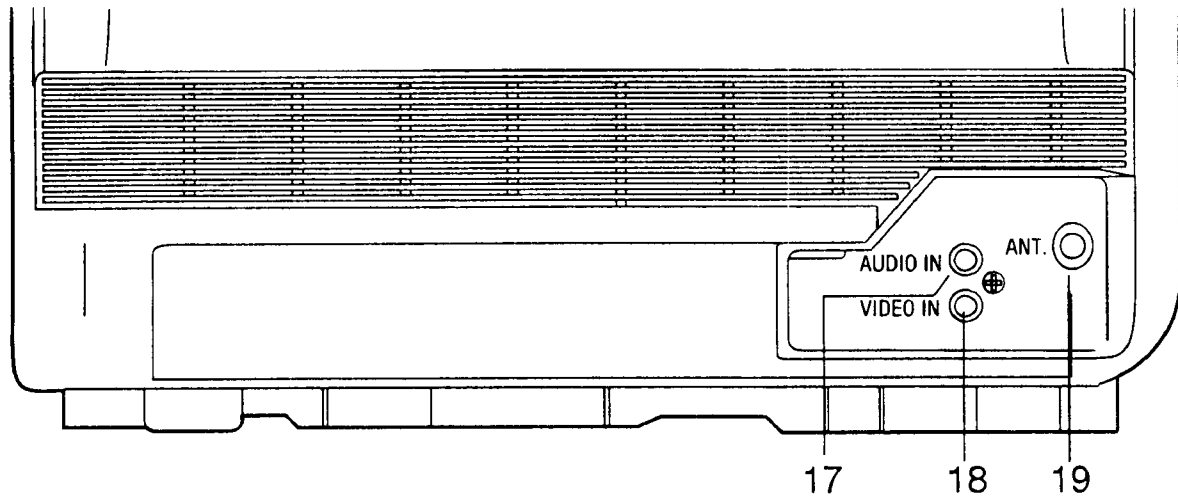

- 17 **AUDIO IN jack**— For connection to audio output jack of your audio equipment or another VCR.
- 18 **VIDEO IN jack**— For connection to video output jack of your video camera or another VCR.
- 19 **ANT. terminal**— For connection to an antenna or CATV.

REMOTE CONTROL OPERATION

You can operate most of functions from the Remote Control (included). The buttons on the Remote Control have the same functions as the corresponding buttons on the unit.

HOW TO USE REMOTE CONTROL

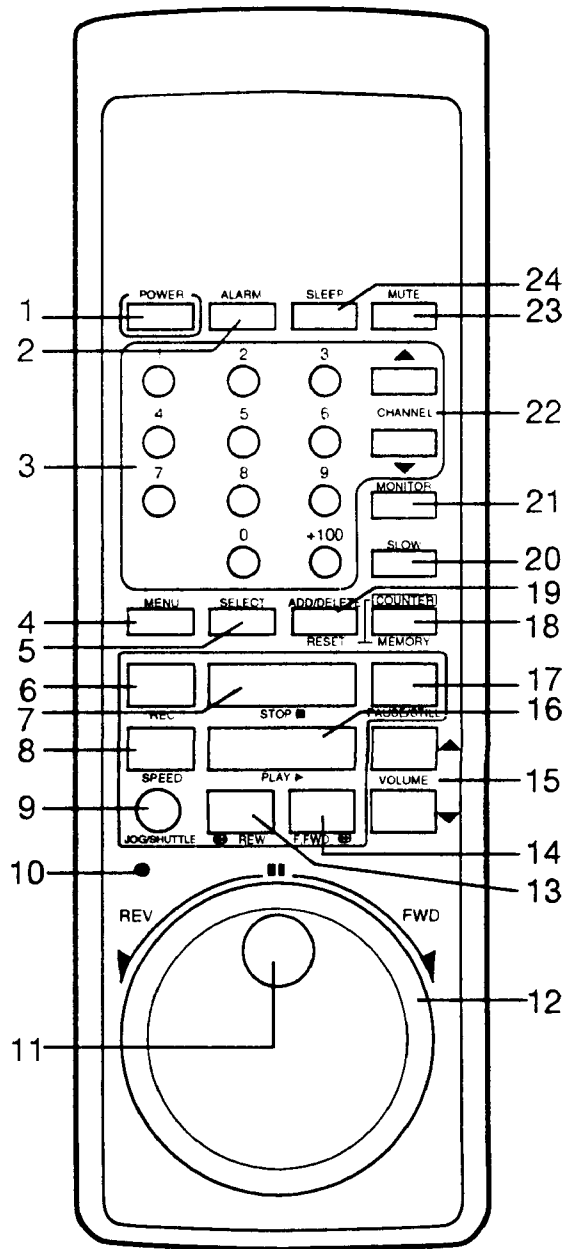

- 1 **POWER button**– Press to turn TV/VCR on and off. Press to activate the automatic timer recording.
- 2 **ALARM button**– Press to set the time to turn on the TV/VCR automatically. (See page 33.)
- 3 **NUMBER buttons**– Press to select desired channels and select item in the Menu mode. They cannot be used to set desired channel during Timer Recording. To select channels 1 to 9, first press the 0 button and then 1 to 9.
+100 button– Press to select channels which are equal or greater than number 100.
- 4 **MENU button**– Press to display main menu on the TV/VCR screen.
- 5 **SELECT button**– Press to select setting modes (clock, counter, tape speed, timer programming, CH preset, etc.).
STATUS function– Press to display the counter or the current channel number and current time on the TV/VCR screen.
- 6 **REC button**– Press to begin manual recording.
- 7 **STOP button**– Press to stop the tape motion.
- 8 **SPEED button**– Press to set desired recording speed. (SP/LP/SLP)
- 9 **JOG/SHUTTLE button**– Press to use the Jog Dial or the Shuttle Ring. (See page 21.)
- 10 **Jog/Shuttle Indicator**– Lights on when JOG/SHUTTLE button is pressed. (See page 21.)
- 11 **Jog Dial**– Turn to advance one frame in the forward or backward direction at the speed with which the dial is turned. (See page 21.)
- 12 **Shuttle Ring**– Turn to make rewind or fast forward speed faster in the forward or backward direction in the Play mode or Still mode. The further the Shuttle Ring is rotated, the faster the playback speed. (See page 21.)
- 13 **REW button**– Press to rewind the tape, or to view the picture rapidly in reverse during the Play mode. (Rewind Search)
SLOW [-] function– Press to control speed in slow motion. (slower)

14 **F.FWD button**— Press to rapidly advance the tape, or to view the picture rapidly in forward during the Play mode. (Forward Search)

SLOW [+] function— Press to control speed in slow motion. (faster)

15 **VOLUME buttons**— Press to adjust desired volume level by using either "▲" or "▼" button.

16 **PLAY button**— Press to playback the tape.

17 **PAUSE/STILL button**— Press to temporarily stop the tape during the Recording mode or to view a still picture during the Play mode.

18 **COUNTER MEMORY button**— Press to use the Counter Memory mode. (See page 23.)

19 **ADD/DELETE button**— Press to add or delete channel numbers. Press to cancel a timer program. (This function is operative only in the Menu mode.) (See pages 15 and 29.)

COUNTER RESET button— Press to reset counter to 0:00:00.

20 **SLOW button** — Press in playback for slow motion. Slow speed can be controlled by pressing F.FWD button (faster) or REW button (slower).

21 **MONITOR button**— Press to turn the TV/VCR screen on and off when in the Recording mode.

22 **CHANNEL buttons**— Press to select desired channel by using either "▲" or "▼" button. They cannot be used during Recording mode. They may also be used to adjust the picture control. (See page 18.)

TRACKING function— Press "▲" or "▼" button to adjust to minimize video 'noise' (lines or dots on screen) during the Play mode. (See page 32.)

23 **MUTE button**— Press to mute sound. Press it again to resume sound.

24 **SLEEP button**— Press to activate the sleep function. (See page 32.)

INSTALLING THE BATTERIES

1

Press the tab to the direction of the arrow.

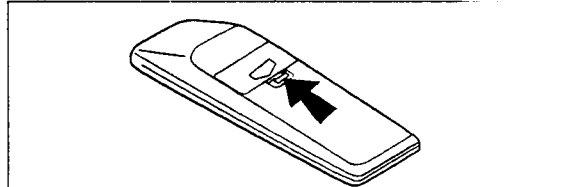

2

Pivot the cover up as shown by the arrow.

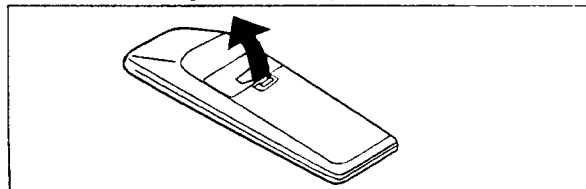

3

Insert 2 "AAA" batteries into the battery compartment in the direction as indicated by the polarity (+/-) markings.

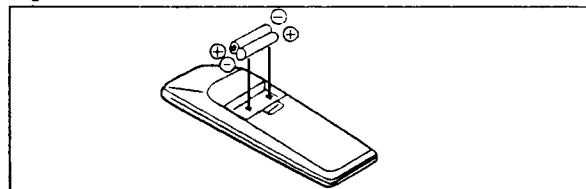

4

Replace the cover.

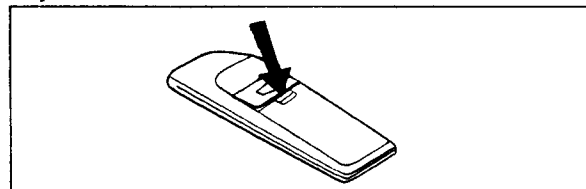

ANTENNA CONNECTIONS

VHF/UHF COMBINED ANTENNA

The VHF/UHF Rod Antenna (supplied) is detachable. Push the stem of the antenna into the hole which is located on the upper back cabinet of the unit. Connect the VHF/UHF Rod Antenna or VHF/UHF Combination Antenna to the ANT. terminal of the TV/VCR as shown in the diagram below.

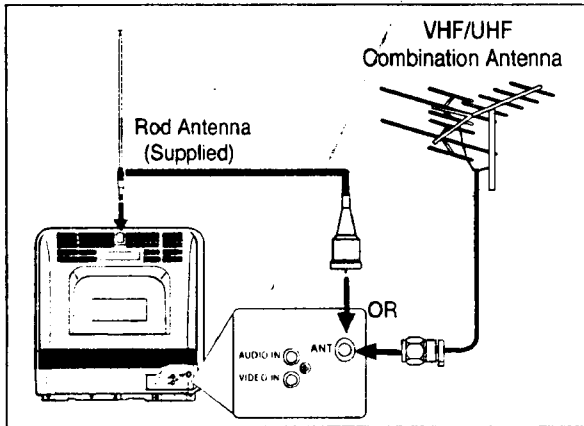

For the best reception, extend the VHF/UHF Rod Antenna fully and adjust its position. (Avoid handling the top section when making adjustments.)

NOTE :

Before plugging the Rod antenna into antenna terminal, check that the pin is not bent. If it is bent, straighten the pin as illustrated, then plug the pin into antenna terminal.

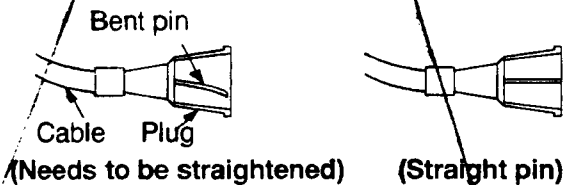

VHF/UHF SEPARATE ANTENNAS

In some areas it will be necessary to use an outdoor antenna.

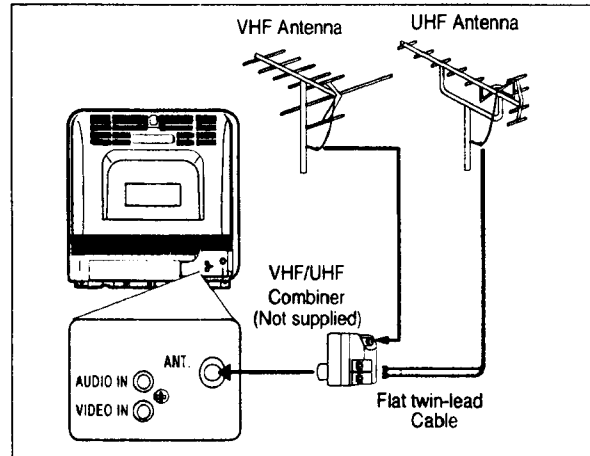

CABLE WITHOUT CONVERTER/DESCRAMBLER BOX

Use this connection if your cable system connects directly to your TV/VCR without a converter box.

With this connection you, 1) can use your TV/VCR Remote Control to select channels, 2) program one or more unscrambled channels for Automatic Timer Recording.

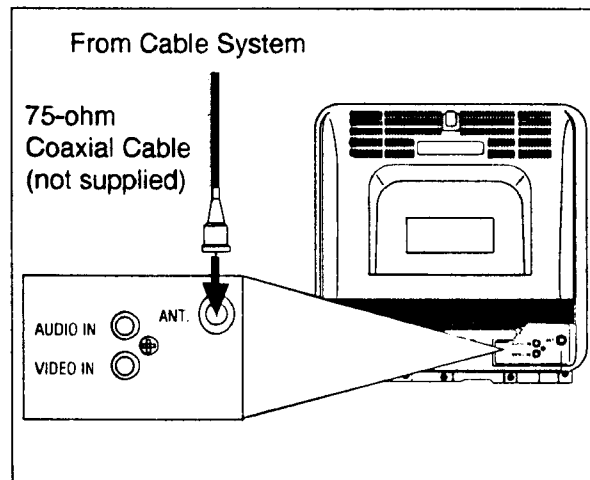

Note to CATV system installer

This reminder is provided to call the CATV system installer's attention to Article 820-40 of the NEC that provides guidelines for proper grounding and, in particular, specifies that the cable ground shall be connected to the grounding system of the building as close to the point of cable entry as practical.

CABLE WITH CONVERTER/DESCRAMBLER BOX

If your cable service supplies you with a converter box you can use the basic connection shown here.

With this connection you can record and view any channel, including scrambled channels. However, channel selection must be made with the converter box. This means that channels cannot be changed using the TV/VCR Remote Control. Unattended recording is limited to one channel at a time.

TO RECORD AND VIEW A SCRAMBLED/UNSCRAMBLED CHANNEL

1. Set the TV/VCR channel selector to the output channel of the Cable Converter Box. (Ex. CH3)
2. Select the channel to be recorded or viewed on the Cable Converter Box.

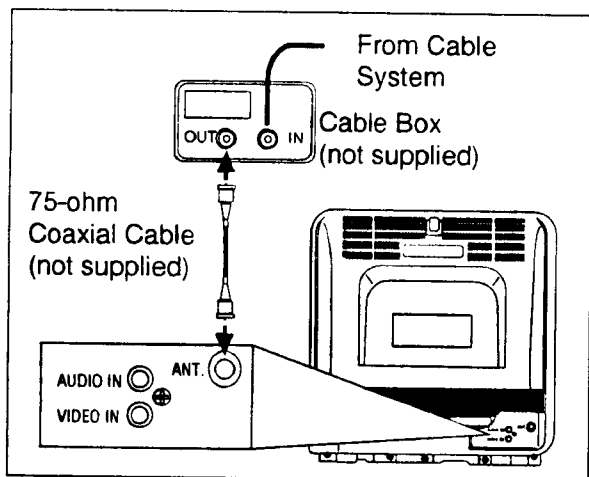

NOTE: When using a cable converter box, you can not record one channel and view.

EXTERNAL INPUT MODE

When using an external input signal another VCR or camcorder, connect the player's audio/video output cables to the AUDIO IN, VIDEO IN jacks of your TV/VCR. Then press CHANNEL ▲ or ▼ button or enter "00" with number button so that AUX appears on the screen.

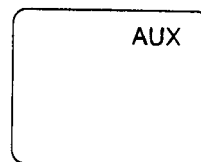

TO COPY A VIDEO CASSETTE (Requires another VCR)

Connect your TV/VCR and a Source (Playing) VCR using the following diagram, using the jacks on the back of the TV/VCR or on the front of the TV/VCR (priority):

1. Insert a pre-recorded video cassette into the Source (Playing) VCR.
2. Insert a blank video cassette, or one you want to record over, into the TV/VCR's cassette compartment.
3. Press SPEED button on the remote control to select the desired recording speed (SP, LP or SLP).
4. Press CHANNEL ▲ or ▼ button repeatedly so that "AUX" appears on the screen.
5. Begin playback of the tape in the Source (Playing) VCR.
6. Press RECORD button on the TV/VCR.

NOTE: For best results during dubbing, use the TV/VCR's front panel controls whenever possible. The remote control might affect the Source (Playing) VCR's playback operation.

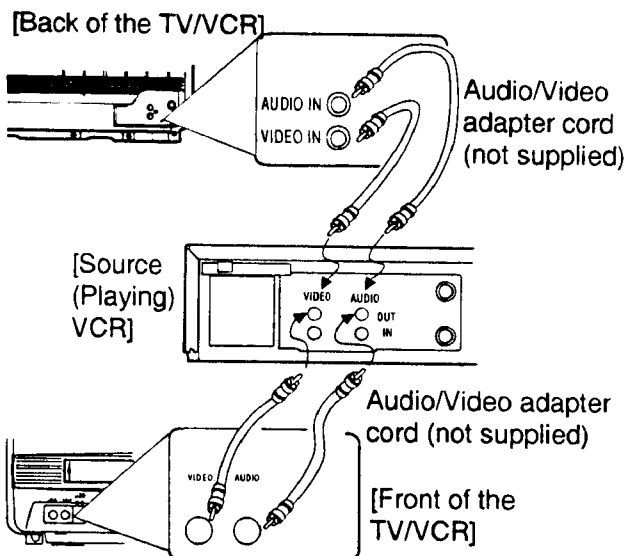

TV/CATV CHANNEL MEMORY PROGRAMMING

You can program the tuner to scan only the channels you receive in your area.

AUTOMATIC CHANNEL MEMORY

NOTE: Channel memory programming is not needed when using a converter/descrambler box.

You must use the remote control unit for the following steps:

1
Plug the TV/VCR power cord into a standard AC outlet. Press POWER button to turn on the TV/VCR.

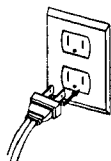

2
Select item 1 (ENGLISH) or 2 (ESPAÑOL=SPANISH) using number 1 or 2 button.

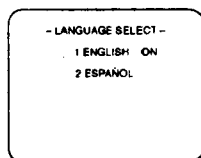

3
Press SELECT button on the remote control unit. The tuner scans and memorizes all the active channels in your area.

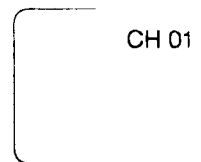

- The TV/VCR distinguishes between standard TV channels and CATV automatically.

4
After scanning, the tuner stops on the lowest memorized channel.
(TV mode: from CH 02/ CATV mode: from CH 01)
If you want to recall the selected channels, you can select the desired channel directly by number button or CHANNEL ▲ or ▼ button on the remote control unit.

TO RETURN TO TV MODE WHEN SCANNING

Press MENU button in scanning mode.

TO PRESET CHANNEL MEMORY AGAIN

1
Press MENU button.
Select item 4 (CHANNEL SET UP) using number 4 button.

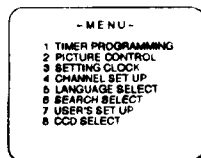

2
If you need, press number 1 button repeatedly to select [TV] or [CATV].

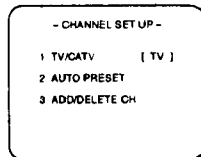

3
Select item 2 (AUTO PRESET) using number 2 button. The tuner scans and memorizes all the active channels in your area.

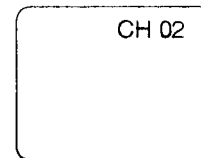

4
After scanning, the tuner stops on the lowest memorized channel.
(TV mode: from CH02 / CATV mode: from CH01)
If you want to recall the selected channels, you can select the desired channel directly by number button or CHANNEL ▲ or ▼ button on the remote control unit.

TO RETURN TO TV MODE WHEN SCANNING

Press MENU button in scanning mode.

TO DELETE OR ADD PRESET CHANNEL

You can delete or add the desired channels.

1

Press MENU button.

Select item 4 (CHANNEL SET UP) using number 4 button.



5

Press MENU button. The TV/VCR screen returns to TV mode.



NOTE: To confirm that channel(s) has been deleted or added, press CHANNEL ▲ or ▼ button.

2

Select item 3 (ADD/DELETE CH) using number 3 button.

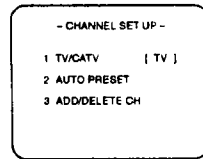

3

Enter the desired channel number using the number button or the CHANNEL ▲ or ▼ button.

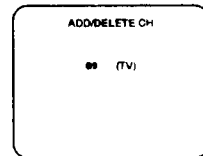

4

DELETING PRESET CHANNEL

Press ADD/DELETE button. The channel number changes to light red. The channel is deleted from memory.

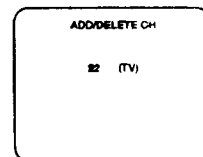

- To delete another channel, repeat steps [3] and [4].
- If you press the ADD/DELETE button again, the channel is memorized again.

ADDING PRESET CHANNEL

Press ADD/DELETE button. The channel number changes to light blue. The channel is added to memory.

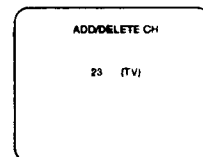

- To add another channel, repeat steps [3] and [4].
- If you press the ADD/DELETE button again, the channel is deleted again.

**Added channel is in light blue.
Deleted channel is in light red.**

MANUAL CLOCK SETTING

Set or correct the clock manually.

- You must use the remote control unit for the following steps:
- Power must be turned on.

In the example below, the clock is to be set to:

DATE March 1st, 1995
 SETTING TIME 5:40PM

1

Press MENU button.
 Select item 3 (SETTING CLOCK) using number 3 button.

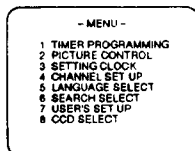

7

Enter the desired minute using number button.

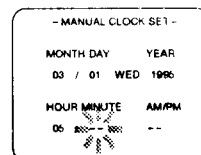

2

Select item 3 (MANUAL CLOCK SET) using number 3 button.

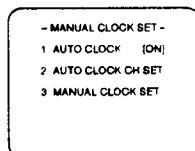

8

Enter 1 to select "AM" or enter 2 to select "PM" using number button.

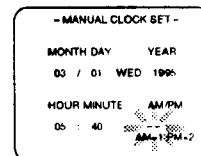

3

Enter the desired month using number button.

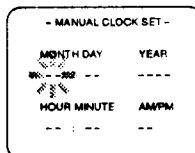

9

Press MENU or SELECT button to start the clock.

Although seconds are not displayed, they begin counting from 00 when you press MENU or SELECT button. Use this feature to synchronize the clock with the correct time.

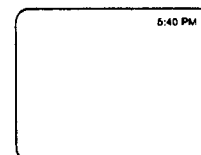

4

Enter the desired day using number button.

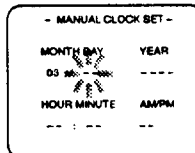

5

Enter the desired year using number button.

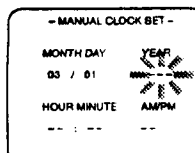

6

Enter the desired hour using number button.

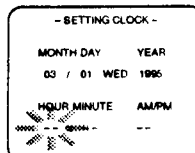

- This unit has a built in calendar up to the year 2008.

TO CHANGE CLOCK SETTING

If you want to change the clock,

- 1) Follow steps [2] and [3].
- 2) Select desired digit using SELECT button or ADD/DELETE button.
- 3) Enter correct numbers using number button.
- 4) Press MENU button to return to TV mode.

HINT!

If there is no local PBS station in your area or on your cable system, in step 2 above, press 1 to turn auto clock setting off, and then adjust clock manually.

TV OPERATION

1
Press POWER button to turn on the TV/VCR.

2
Select the desired channel using number button or CHANNEL ▲ or ▼ button.

3
Adjust the VOLUME to desired listening level using the VOLUME ▲ or ▼ button.

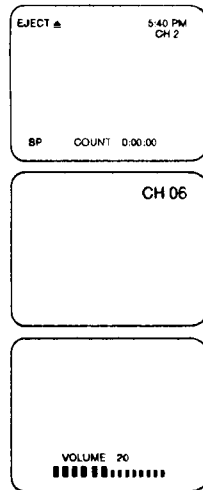

GAME MODE

This function enables you to adjust the TV/VCR display making it suitable for use with a TV GAME.

- You must use the remote control unit for the following steps:

1
Press MENU button.
Select item 7 (USER'S SET UP) using number 7 button.

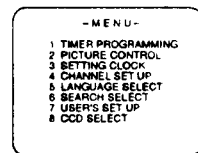

2
Press number 1 button to select (GAME MODE [ON]).

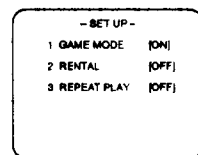

3
Press MENU button to return to TV mode.

TO CANCEL THE GAME MODE

- Repeat steps [1]. Then, follow step [2] to select [OFF]. Press MENU button to return to TV mode.

OR

- Set the PICTURE CONTROL. The GAME MODE will then automatically be turned [OFF].

PICTURE CONTROL

Adjust picture controls for a natural looking image.

- You must use the remote control unit for the following steps:

1
Press MENU button.

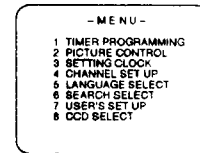

2
Select item 2 (PICTURE CONTROL) using number 2 button.

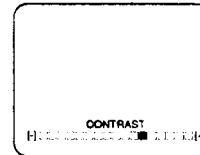

3
Press SELECT button repeatedly until desired control is displayed.

Each time you press SELECT button, CONTRAST, BRIGHT, COLOR, TINT and SHARPNESS will appear on the screen in sequence.

4
Adjust the picture control using CHANNEL ▲ or ▼ button.

- Your TV/VCR's picture controls — CONTRAST, BRIGHT, COLOR, TINT and SHARPNESS — are preset to the factory specification. This is usually best, but if you need to make any further adjustments, use the following chart as a guide.

	CH ▼	CH ▲
CONTRAST	to decrease contrast	to increase contrast
BRIGHT	to decrease brightness	to increase brightness
COLOR	to pale	to brilliant
TINT	to purple	to green
SHARPNESS	to soft	to clear

NOTE: When setting the PICTURE CONTROL, the GAME MODE will be automatically set to [OFF].

CLOSED CAPTION SYSTEM

You may view specially labeled (cc) TV programs, movies, news, prerecorded tapes, etc. with either a dialogue caption or text display added to the program.

Caption Mode

You may watch dramas, movies and news etc. while captioning the dialogues and the contents of news if you want by choosing the caption mode.

Text Mode

You may watch full screen text information if you want by choosing the text mode.

C1/C2

You may get these captions or text information by selecting either C1 or C2. C2, when used, will usually be for a second language.

- You must use the remote control unit for the following steps:
- Power must be turned on.

1

Press MENU button.

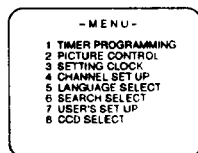

2

Select item 8 (CCD SELECT) using number 8 button.

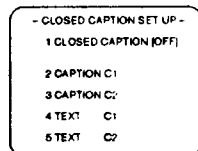

3

Select your desired item 2 (CAPTION C1) through 4 (TEXT C2) using the number button. [ON] appears besides the item.

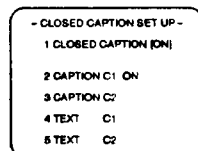

4

Press MENU button. The selected caption broadcast appears on the TV/VCR screen.

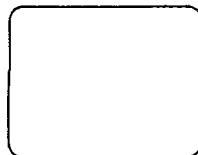

NOTE:

Not all programs are broadcast with closed captions. Your television is designed to provide error free closed captions from high quality antenna, cable and VCR signals. Conversely, poor quality signals are likely to result in caption errors or no captions at all. Common signal conditions which may cause captions errors are listed below;

- Automobile ignition noise.
- Electric motor brush noise.
- Weak snowy picture.
- Multiplex signal reception displaying picture ghosts or airplane flutter.
- Playback of poorly recorded or worn VCR tapes.
- If your TV/VCR displays a black box on the screen, this means that your TV/VCR is set to TEXT mode. To clear screen, select CAPTION C1, C2 or CLOSED CAPTION [OFF].



When the Closed Caption mode is ON:

The On Screen Display will disappear after 5 seconds.

- This is true even if MUTE button is pressed, or PAUSE/STILL button is pressed while recording. However, On Screen Display will appear for 5 seconds when SELECT button is pressed.

TO CANCEL THE CLOSED CAPTION SYSTEM

Repeat steps [1] and [2]. Then, follow step [3], select item 1 (CLOSED CAPTION [OFF]) using number 1 button.

PLAYBACK

Power must be turned on.

1

Insert a cassette into the cassette compartment.

NOTE: If the erase-protection tab has been removed, the TV/VCR will start playback automatically.

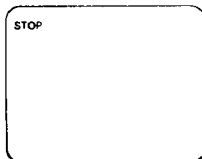

2

If playback does not begin automatically, press PLAY button.

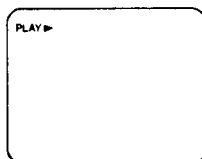

3

Press STOP button when playback is completed.

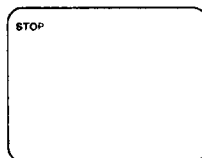

VISUAL SEARCH (SP/LP/SLP MODE)

You may view a video tape at a high speed in either a forward or reverse direction. This feature is useful in finding or skipping over a particular scene on a tape.

Forward Direction:

When in the Play mode, press F.FWD button to view the tape at a fast speed in the forward direction. The sound will be muted.

Reverse Direction:

To view the tape at a fast speed in the reverse direction, press REW button. The sound will be muted.

Press PLAY button to return to normal playback.

NOTE: The picture will not be as good as in normal playback during Visual Search.

SUPER HIGH SPEED SEARCH (LP/SLP MODE)

For Visual Search in super high speed:

- 1) Press either F.FWD or REW button while the unit is in the Play mode.
- 2) Release button.
- 3) Depress it again. The unit will now search in super high speed.

Press PLAY button to return to normal playback.

NOTE: Tapes recorded in the SP or LP mode will display a noise bar on the TV/VCR screen and the picture may revert to Black and White. This is normal.

STILL PICTURE DURING PLAYBACK

If you press PAUSE/STILL button during the Play mode, the picture will "freeze" on the TV/VCR screen. You may use this feature to study details of a particular scene.

Press PLAY button to continue playback.

NOTE: The TV/VCR will automatically switch to the Stop mode, if it is left in the Pause/Still mode for more than five minutes.

SLOW MOTION

Press SLOW button to reduce the playback speed. The TV/VCR mutes the sound during slow motion. You can control the speed by pressing F.FWD button (faster) or REW button (slower).

Press PLAY button to return to normal playback.

JOG AND SHUTTLE FUNCTION

You can view the playback picture at a high speed or advance one frame using the Jog and Shuttle function.

1

Press JOG/SHUTTLE button in the Play mode or Still mode. The Jog/Shuttle indicator lights on. The picture will freeze on the screen. No action for Jog/Shuttle in 30 seconds makes the Jog/Shuttle indicator light off.

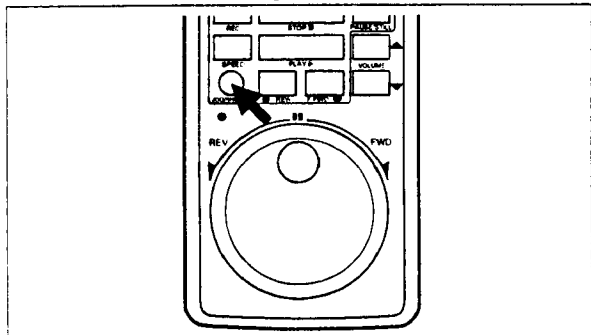

2

TO MAKE THE PLAYBACK SPEED FASTER

Hold and turn the Shuttle Ring (the outer ring) in either direction. The further the ring is rotated, the faster the playback speed in the forward (FWD) or reverse (REV) direction. If you release the ring, the ring will returned to the original position and the picture will be in the Still mode.

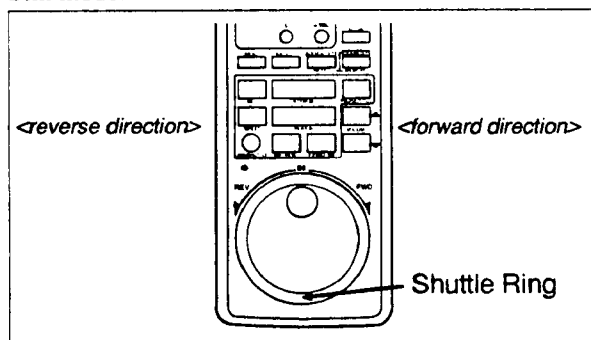

3

TO ADVANCE THE FRAME ONE BY ONE

Turn the Jog Dial (the inner dial) in either direction. The faster the dial is rotated, the faster the one frame advance one by one in the forward (FWD) or reverse (REV) direction.

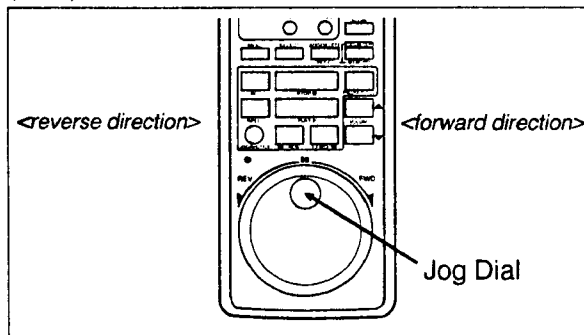

4

Press PLAY button for normal playback.

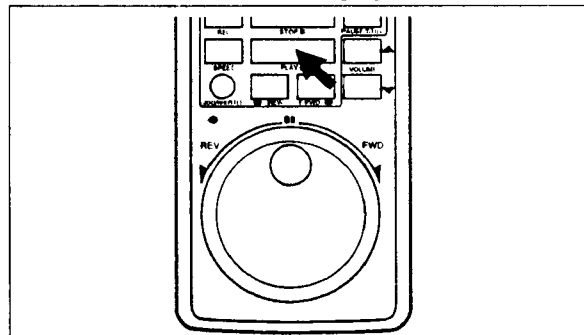

NOTE: When noise lines appear on the still picture, change to slow mode and adjust tracking as described in Slow Tracking.

SPECIAL PLAYBACK

RENTAL PLAY

This function enables you to improve the picture quality when playing back worn cassettes such as those rented from a video shop.

- Before playback, follow steps below.
- You must use the remote control unit for the following steps:
- Power must be turned on.
- Make sure that a cassette tape is in the TV/VCR.

1

Press MENU button.
Select item 7 (USER'S SET UP) using number 7 button.

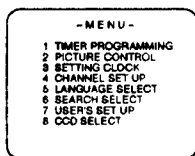

2

Press number 2 button to select (RENTAL [ON]).

- Once you select the Rental Play mode, it stays in effect even after you turn off the TV/VCR.

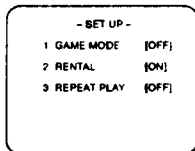

3

First press MENU button, then press PLAY button to start the Rental play.

TO EXIT THE RENTAL PLAY MODE

Repeat steps [1]. Then, follow step [2] but select [OFF]. Press MENU button to return to TV mode.

AUTO REPEAT PLAYBACK

The TV/VCR has an auto repeat function that allows you to repeat a tape indefinitely without using the PLAY button. There are two selections for Auto Repeat Playback.

ALL REPEAT: repeat playback from the beginning to the end of the tape.

BLANK REPEAT: repeat playback from the beginning of the tape to the first blank section of the tape it must be blank for more than 10 seconds.

- Before playback, follow steps below.
- You must use the remote control unit for the following steps:
- Power must be turned on.
- Make sure that a cassette tape is in the TV/VCR.

1

Press MENU button.
Select item 7 (USER'S SET UP) using number 7 button.

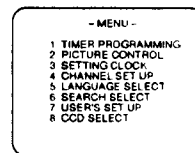

2

Press number 3 button repeatedly to select [ALL] or [BLANK]. [ALL] or [BLANK] appears besides the "REPEAT PLAY".

- Once you select the Repeat Play mode, it stays in effect even after you turn off the TV/VCR.

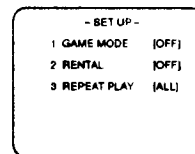

3

First press MENU button, then press PLAY button to start the Repeat Play. "REPEAT PLAY ►" appears.

- If the rental play function is set ON, the "RENTAL PLAY ►" display has priority.

NOTES:

- 1) All buttons except POWER and STOP buttons do not work during Auto Repeat Playback. Always set the Auto Repeat Playback function to [OFF] when not in use.
- 2) If the Counter Memory (See page 23) is activated, the tape will automatically stop when the count returns to approx. 0:00:00 during Auto Rewind.

TO EXIT THE REPEAT PLAY MODE

Press STOP button to stop playback. And repeat steps [1], then follow step [2] but select [OFF]. Press MENU button to return to TV mode.

COUNTER MEMORY

The Counter Memory can be used during rewind or fast forward to automatically stop the tape when the count reaches a preset memory position of approx. 0:00:00 reading.

For example, this feature can be used to return the tape to a pre-selected position immediately after recording, or to repeatedly playback a certain portion of a tape.

- You must use the remote control unit for the following steps:
- Power must be turned on.
- Make sure that a cassette tape is in the TV/VCR.

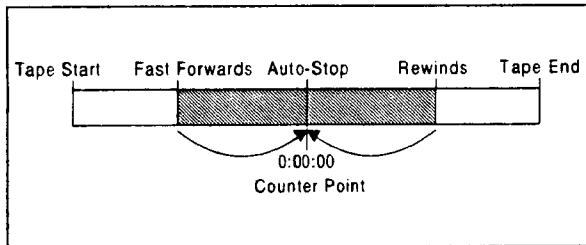

1
If the count is displayed on the TV/VCR screen, skip step [1].

If the count is not displayed, press SELECT button so that the counter appears on the TV/VCR screen.

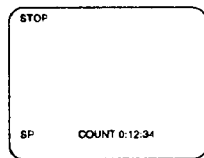

2
Press COUNTER RESET button. The count resets to 0:00:00.

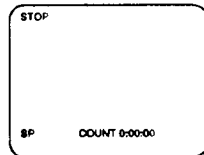

3
Press COUNTER MEMORY button. "MEMORY" appears on the screen.

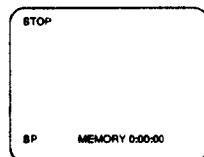

4
Press REC or PLAY button.

5
Press STOP button when recording or playback is completed.

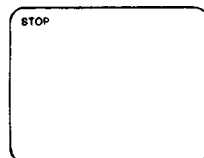

6
Press SELECT button so that the counter appears.

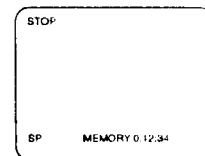

7
Press REW button. The tape will automatically stop when the count returns to approx. 0:00:00.

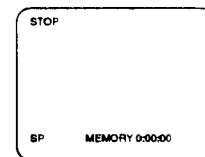

TO CANCEL THE COUNTER MEMORY

1
Press SELECT button so that the counter appears on the TV/VCR screen.

2
Press COUNTER MEMORY button so that "COUNT" appears on the TV/VCR screen.

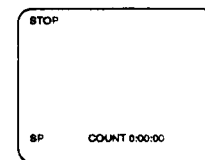

SEARCH SELECT

TIME SEARCH

The Time Search function makes it possible to quickly advance the tape from any position by entering the exact desired amount of playback time of the part that you want to skip.

- You must use the remote control unit for the following steps:
- Power must be turned on.
- Make sure that a cassette tape is in the TV/VCR.

In the example below, search the position after 2 hours 53 minutes from now.

1

Press MENU button.

Select item 6 (SEARCH SELECT) using number 6 button.

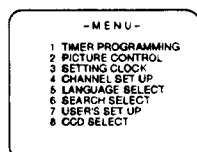

2

Select item 1 (TIME SEARCH) using number 1 button. The hour digit flashes.

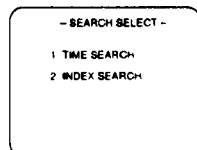

3

Enter the desired hour with number button.

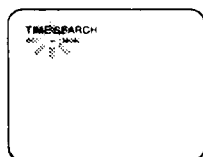

4

Enter the desired minutes with number button.

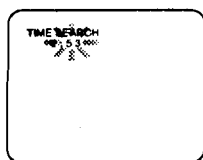

- To correct the hour, press DELETE button and repeat steps [3] and [4].
- To correct the minute, enter correct numbers using number button.
- To cancel the Time search function, press MENU button.

5

Press F.FWD or REW button. The tape will move to the specified point.

The time counts down as the searching progresses. When 0:00 is reached, the tape will start playback automatically.

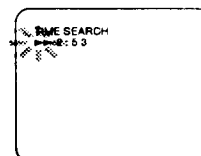

NOTES:

- Time search can be set up to 9:59.
- This function is not operative in recording mode.
- Counter Memory function is not operative in this mode.
- This function is not operative when a cassette tape is not inserted in the TV/VCR.
- The time will not count down during blank sections of tape.

TO FINISH THE TIME SEARCH MODE

Press STOP button on the TV/VCR or remote control unit. This will delete the selected time.

INDEX SEARCH

This feature provides a method of indexing the starting point so that it can be easily returned to in either fast forward or rewind mode.

- The index mark will be made automatically when the REC button is pressed. It will also be marked at the starting point of Timer recording and OTR.
- The index mark is not recorded if the PAUSE/ STILL button is pressed and released during recording.
- The time gap between making the index marks on the tape should be greater than 1 minute for SP recording, 2 minutes for LP recording and 3 minutes for SLP recording.
- Index marks cannot be made if the erase-protection tab on the cassette has been removed.

NOTES:

- You must use the remote control unit for the following steps:
- Power must be turned on.
- Make sure that a cassette tape is in the TV/VCR.

Example: You are watching fourth program (program number 4) and want to fast forward to seventh program (program number 7). You must skip three programs.

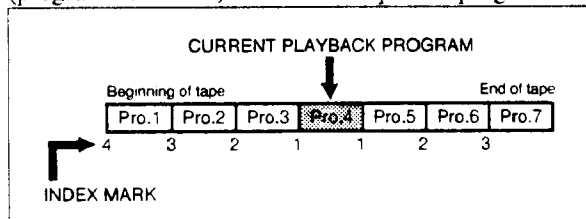

1

Press MENU button.

Select item 6 (SEARCH SELECT) using number 6 button.

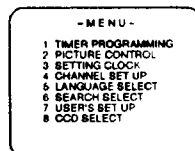

2

Select item 2 (INDEX SEARCH) using number 2 button.

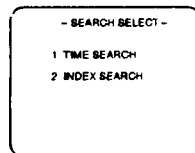

3

Press the number button corresponding to the number of program that you want to skip. (Example: To skip three programs, press number button 03.)



- To correct the Index number, press DELETE button and re-enter the correct number.

4

Press REW or F.FWD button. The TV/VCR begins rewinding or fast forwarding then goes into the Play mode at the beginning of desired program.

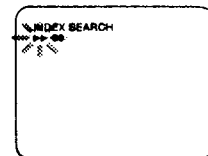

NOTE: Every time an index signal is skipped, the number in the program indicator decreases by one.

5

When the preset program is reached, normal playback will start.

NOTES:

- Index search can be set up to 20.
- This function is not operative in recording mode.
- Counter Memory function is not operative in this mode.
- Press STOP button on the TV/VCR or remote control to end the Index Search.

VIEWING AND RECORDING THE SAME PROGRAM

You can only watch the same TV program that is being recorded.

NOTE: You may not have good results if you try to record a video game, or computer generated display, etc.

1

Insert a blank cassette, or one that you want to record over, into the cassette compartment.

If necessary, rewind or fast forward the tape to the point you want to start recording.

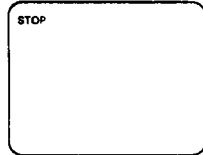

2

Make sure the TIMER REC. indicator is off. If it lights up, press POWER button to turn on the TV/VCR.

3

Press SPEED button on the remote control repeatedly until the desired recording speed is displayed (SP/LP/SLP).

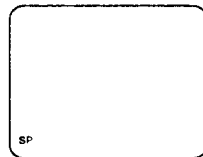

4

Select the channel to be recorded by using the number button or the CHANNEL ▲ or ▼ button.

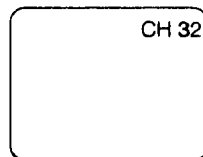

5

Press REC button. Recording indicator lights up.

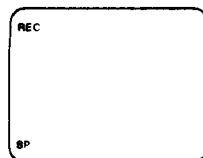

To skip some material while you are recording:

6

Press PAUSE/STILL button on the remote control to temporarily stop recording. Recording indicator light blinks.

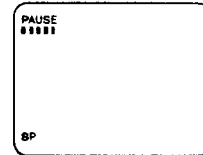

NOTES:

- If the TV/VCR is left in the Pause/Still mode for more than 5 minutes while Recording, it will automatically switch to the Recording mode. When in the Pause/Still mode, a display showing 5 "■" marks will appear on the screen. Each "■" mark represents one minute of Pause time. You may refer to this display for remaining pause time available.
- If "CLOSED CAPTION [ON]" is selected from the "CLOSED CAPTION SET UP" menu, the On Screen Display will appear for 5 seconds, then disappear. If you want to check the remaining pause time available using the On Screen Display, press SELECT button. The On Screen Display will appear for 5 seconds.

7

Press PAUSE/STILL or REC button to resume recording.

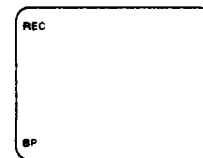

8

Press STOP button when recording is completed.

OTR (ONE TOUCH RECORDING)

The One Touch Recording function enables you to record a program simply by using the OTR button on the TV/VCR.

According to the table, simply press OTR button as many times as needed to set the desired recording length. The channel number to be recorded and recording length will be shown on the TV/VCR screen.

- This function is not operative using the remote control.

1

Insert a blank cassette, or one that you want to record over, into the cassette compartment.

If necessary, rewind or fast forward the tape to the point you want to start recording.

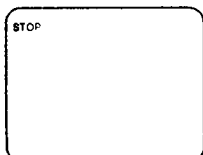

2

Select the channel to be recorded.

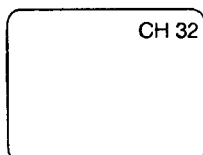

3

Press REC/OTR button on the TV/VCR.

Recording starts immediately when the REC/OTR button is pressed at least two times, even if you are watching a TV program.

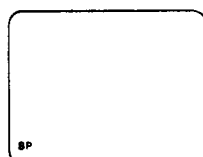

Push(es)	DISPLAY	LENGTH
1 push	NORMAL REC MODE	
2 pushes	0:30	30 minutes
3 pushes	1:00	60 minutes
4 pushes	1:30	90 minutes
5 pushes	2:00	120 minutes
6 pushes	2:30	150 minutes
7 pushes	3:00	180 minutes
8 pushes	3:30	210 minutes
9 pushes	4:00	240 minutes
10 pushes	4:30	270 minutes
11 pushes	5:00	300 minutes
12 pushes	5:30	330 minutes
13 pushes	6:00	360 minutes
14 pushes	6:30	390 minutes
15 pushes	7:00	420 minutes
16 pushes	7:30	450 minutes
17 pushes	8:00	480 minutes
18 pushes	NORMAL REC MODE	

TO STOP THE OTR OPERATION

Press STOP button on the TV/VCR or remote control.

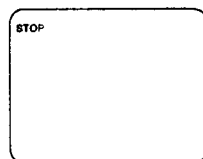

The timer on the TV/VCR screen counts down as the recording progresses.

NOTES:

- Each time you press OTR button, you will extend the recording time by 30 minutes at a time up to 8-hours (or to the end of the tape).
- When the OTR button is pushed 18 times, the TV/VCR will record continuously until the end of the tape.
- The recording length time remaining will be displayed on the TV/VCR screen as the recording is started.
- Recording stops when 0:00 is reached.
- Please note that in the SLP mode maximum recording time, assuming the tape is started of the beginning, is 8 hours using T-160 (or 6 hours using T-120).

AUTOMATIC TIMER RECORDING

You may set the TV/VCR to record while you are away. You can set seven events to record on a specific day, daily or weekly within a 1 year period.

- You must use the remote control unit for the following steps:
- Be sure the clock is set to the correct time and date before setting the timer.
- Power must be turned on to set automatic timer recording.

In the example below, the timer is being set to record:

PROGRAM NUMBER 4
 DATE MAY 6th, 1995
 SETTING TIME from 7:30AM to 8:50AM
 CHANNEL CH61
 TAPE SPEED LP

1

Insert a blank cassette, or one that you want to record over, into the cassette compartment.

If necessary, rewind or fast forward the tape to the point you want to start recording.

2

Press MENU button.

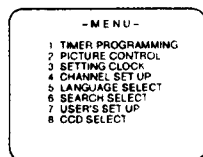

3

Select item 1 (TIMER PROGRAMMING) using number 1 button.

The program numbers which are not set up will flash.

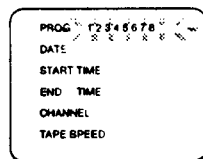

4

Enter your desired program number using number button.

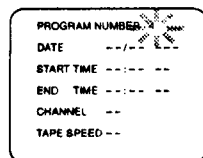

- The program number 8 is used for setting QUICK SET PROGRAM only. You cannot select number 8 in the procedure of Automatic Timer Recording.
- When a Timer Recording is being carried out, you cannot set or change any programming of Timer Recording.

5

Press SELECT button.

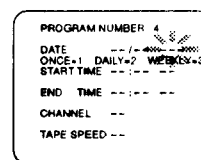

6

Enter 1 to select "ONCE", enter 2 to select "DAILY" or enter 3 to select "WEEKLY" using number button.

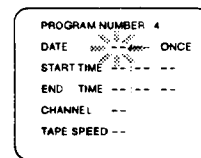

- To record the program once, press number 1 button to select "ONCE".
- To record the same program every day from Sunday through Saturday (such as soap operas and other daily serials), press number 2 button to select "DAILY".
- To record the same program every week on the same day (such as every Saturday), press number 3 button to select "WEEKLY".

7

Enter your desired month using number button. Regarding to "DAILY" and "WEEKLY", enter the date you want to start it.

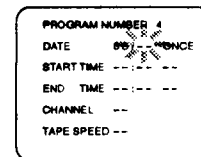

8

Enter your desired day using number button. The day of the week changes automatically.

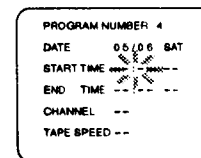

9

Enter your desired hour using number button.



10

Enter your desired minute using number button.

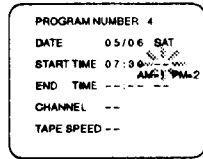

11

Enter 1 to select "AM" or enter 2 to select "PM" using number button.

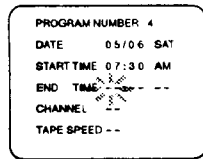

12

Repeat steps [9]-[11] to set the end time.

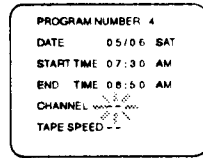

13

Enter your desired channel using number button.

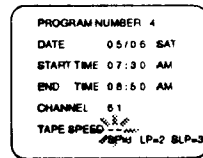

14

Enter 1 to select "SP", enter 2 to select "LP" or enter 3 to select "SLP" using number button.

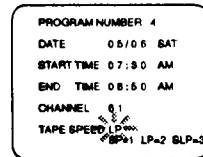

15

Press MENU or SELECT button on the remote control unit. Program 4 is now completed.

To set another program, repeat steps [2] to [15].

16

Press POWER button to set automatic timer recording. The TIMER REC indicator lights up.

- While watching TV, "TIMER REC STANDBY" starts flashing on the TV/VCR screen 2 minutes before the programmed start time.

You must turn off the TV/VCR to activate automatic timer recording.

TO CORRECT A PROGRAM

- While setting a program; press DELETE button to go back one step, and enter correct numbers using number button.
- After setting a program; repeat steps [2] ~ [4] and press SELECT button repeatedly (or press DELETE button to go back one step) until your desired digit flashes and re-set program.

TO CANCEL AN AUTOMATIC TIMER RECORDING

- While setting or after setting a program; repeat steps [2] ~ [4] and press DELETE button.
- While recording is in progress; press MONITOR button, then press STOP/ EJECT button on the TV/VCR. If you press POWER button to turn off before the end time, timer recording will continued. Repeat steps [2] ~ [4] and press DELETE button.

WHEN THE PROGRAMS OVERLAP

The earlier program has priority.

If you programmed as per the illustration the timer recording would be carried out as follows:

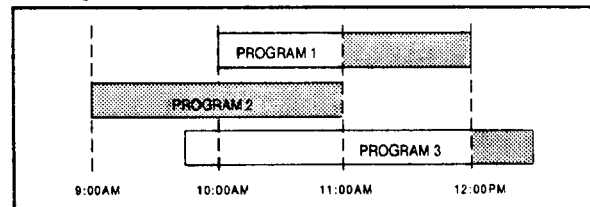

9:00AM - 11:00AM for PROGRAM 2
 11:00AM - 12:00PM for PROGRAM 1
 12:00PM - for PROGRAM 3

QUICK SET PROGRAM

You may set the TV/VCR to record one program within 24 hours by simply pressing MONITOR button on the TV/VCR. It is easy for you to record today's TV program.

- **QUICK SET PROGRAM can not be programmed by the remote control. This function can only be programmed from the TV/VCR.**
- Power must be on to set the Quick Set Program.
- Clock must be set to the correct time before setting the timer.
- QUICK SET PROGRAM Recording is memorized to program number 8.

In the example below, the Quick Set Program is being set to record. (Current time is 8:00PM):

SETTING TIME from 10:00PM to 11:00PM
 CHANNEL CH10
 TAPE SPEED SP

1

Insert a blank cassette, or one that you want to record over, into the cassette compartment.

If necessary, rewind or fast forward the tape to the point you want to start recording.

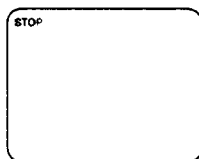

2

Press MONITOR button on the TV/VCR.



NOTES:

- You may forward to the next step by pressing VOLUME ^ button on the TV/VCR.
- When you press VOLUME v button on the TV/VCR, all selections will be erased and the TV/VCR screen will return to the initial display (step [2]).

3

Press CHANNEL ^ or v button until your desired hour is displayed.

Press VOLUME ^ button.



4

Press CHANNEL ^ or v button until your desired minute is displayed.

Press VOLUME ^ button.



5

Press CHANNEL ^ or v button until AM or PM is displayed.

Press VOLUME ^ button.

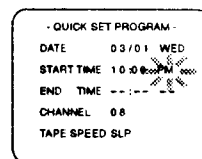

6

Repeat steps [3] - [5] to set the end time.

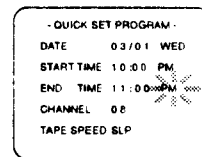

7

Press CHANNEL ^ or v button until your desired channel number is displayed.

Press VOLUME ^ button.



8

Press CHANNEL ^ or v button until your desired tape speed is displayed.

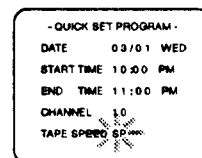

9

Press MONITOR button.

10

Press POWER button to set QUICK SET PROGRAM Recording. The TIMER REC indicator lights up.

- If power is not turned off and you continue watching TV, "TIMER REC STANDBY" starts flashing on the TV/VCR screen 2 minutes before the programmed start time.

You must turn off the TV/VCR to activate QUICK SET PROGRAM Recording.

TO CORRECT A PROGRAM

- **While setting a program;** Press VOLUME ∨ button on the TV/VCR to go back one step, and enter corrected digit.
- **After setting a program;** repeat steps [2] and press VOLUME ∧ button repeatedly (or press VOLUME ∨ button to go back one step) until your desired digit flashes and re-set program.

TO CANCEL A QUICK SET PROGRAM

- **While setting or after setting a program;** 1) press POWER button. 2) press MONITOR button, then, press VOLUME ∨ button.
- **While recording is in progress;** 1) press MONITOR button. 2) press STOP/ EJECT button on the TV/VCR. If you press POWER button to turn off before the end time, timer recording will continue.

WHEN THE PROGRAMS OVERLAP

Quick Set Program has priority. However, if another program has been activated before the start of the Quick Set Program, the Quick Set Program will begin after the other program has finished.

If you programmed as per the illustration the timer recording would be carried out as follows:

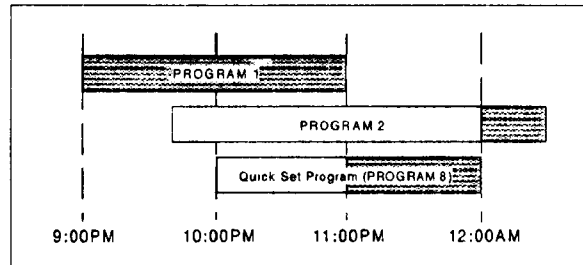

9:00PM - 11:00PM for PROGRAM 1
11:00PM - 12:00AM for PROGRAM 8
(Quick Set Program)
12:00AM - for PROGRAM 2

HINTS ON AUTOMATIC TIMER RECORDING AND QUICK SET PROGRAM

- Make sure the channel you want to record is properly set in advance.
- It is not necessary to press REC button for timer recording.
- Recording begins automatically at the set of the Start time.
- If you are recording using a Timer mode, you may not operate the unit manually.
- The erase-prevention tab on the cassette must be in place (or you must put tape over the hole).
- If the erasure protection tab is removed, the cassette will be ejected when the POWER button is pressed to off, and the TIMER REC indicator flashes.
- If the POWER button is pressed to off with no cassette loaded, the TIMER REC indicator flashes.
- If the TIMER REC indicator flashes, insert a tape with the erase-prevention tab intact. The TIMER REC indicator will illuminate.
- If the tape runs out before the end time, the TV/VCR will switch to the Stop mode immediately, and the tape will be ejected.
- If there is a power failure or if the TV/VCR is unplugged for more than a few seconds, the clock and timer settings will be lost. At this time, the TV/VCR screen will automatically return to the Clock Set mode when you choose the Program Set mode.

TO CHECK THE START/END TIME

- 1) Press POWER button so that the TIMER REC indicator goes off.
- 2) Press MENU button on the remote control.
- 3) Select item 1 (TIMER PROGRAMMING) using number 1 button.
- 4) Enter your desired program number using number button. The details of selected program appears on the TV/VCR screen.
- 5) Press MENU button. The TV/VCR screen returns to the TV mode.

SPECIAL FEATURES

DEGAUSSING

Magnetism from nearby appliances might affect the color of the TV picture.

If this happens, move this unit away from the appliance. If the color is still not correct, disconnect power cord from AC outlet then reconnect it after 30 minutes.

AUTO REWIND-EJECT

- When the end of a tape is reached during recording, playback, or fast-forward, the tape will automatically rewind to the beginning (or to the 0:00:00 count reading if the memory function is activated), power off and tape ejects.
- This function is operative when Auto Repeat is set to the [OFF] position.
- The tape will not auto-rewind during timer recording or One Touch Recording.
- When the tape is rewound to the preset memory position or the REW button is pressed during Auto Rewind, the tape will not eject and TV/VCR will not turn off.

TRACKING ADJUSTMENT

- Tracking adjustment will be set automatically (Digital Tracking function) when you start playback.
- When playing pre-recorded tapes or tapes recorded on units other than your own, noise lines (black and white streaks) may appear on the playback picture. If this occurs, adjust the tracking control by pressing CHANNEL \wedge or \vee button until the streaks disappear. To return to the DTR function, stop the tape once and start playback again.
- To set center position, press both CHANNEL \wedge and \vee button at the same time.
NOTE: This function is controlled only by the buttons on the TV/VCR. The buttons on the remote control will not adjust tracking.

Slow Tracking

- You can reduce the noise lines by pressing CHANNEL " \blacktriangle " or " \blacktriangledown " button in slow mode, too. But you cannot set center position in slow mode, and slow tracking adjustment will not be set automatically.

NOTE: Press SLOW button in Still mode and press CHANNEL " \blacktriangle " or " \blacktriangledown " button until the streaks disappear. To return to Still mode, press PAUSE/ STILL button again.

This enables you to see the picture in its entirety without distracting noise lines.

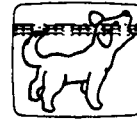

TO CHANGE THE LANGUAGE

You can change the language of the on screen display. Follow the steps below:

- 1) Press MENU button on the remote control.
- 2) Select item 5 (LANGUAGE SELECT) using number button.
- 3) Select item 1 (ENGLISH) or 2 (ESPAÑOL=SPANISH) using number button.
- 4) Press MENU button to return to TV mode.

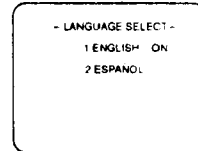

SETTING THE SLEEP TIMER

The sleep timer function enables you to turn off the TV/VCR without using the POWER button after a desired time period.

Press SLEEP button on the remote control repeatedly until desired SLEEP time is displayed.

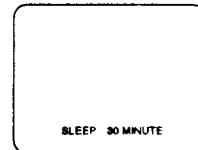

	SLEEP TIME	DISPLAY
1 push	0 minute	0 MINUTE
2 pushes	30 minutes	30 MINUTE
3 pushes	60 minutes	60 MINUTE
4 pushes	90 minutes	90 MINUTE
5 pushes	120 minutes	120 MINUTE
6 pushes	0 minute	0 MINUTE

TO CANCEL THE SLEEP TIMER

The turn off time can be determined by the number of times you press the SLEEP button. Press SLEEP button on the remote control repeatedly until "SLEEP 0 MINUTE" is displayed.

SETTING THE ALARM TIMER

The alarm function enables you to turn on the TV/VCR without using the POWER button after a desired time period.

In the example below, the alarm timer is being set to 7:30 AM.

TO SET THE ALARM TIME

1
Press ALARM button on the remote control.

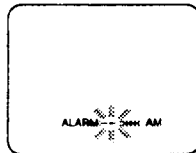

2
Enter the desired hours using number button.

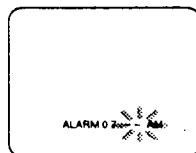

3
Enter the desired minutes using number button.

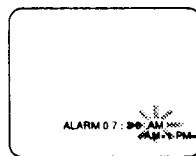

4
Enter 1 to select "AM" or enter 2 to select "PM" using number button.

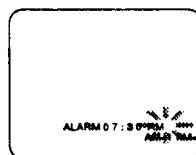

- To correct the time, press DELETE button and repeat steps [2] and [4].

TO ACTIVATE THE ALARM TIMER

5
Confirm the alarm time is correctly entered.

- To see the alarm time, press ALARM button. When "ALARM OFF" appears on the screen, repeat steps [1] ~ [4]).

6
Press ALARM button again. "ON" appears next to the alarm time on the screen.
The TV/VCR will turn on automatically at the set time.

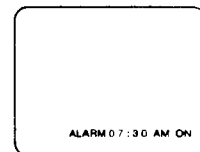

TO CANCEL THE ALARM TIMER

Press ALARM button repeatedly so that "ALARM OFF" appears on the screen.

TROUBLESHOOTING GUIDE

If you have followed the instructions contained in this manual and have difficulty in operating your TV/VCR, locate the SYMPTOM in the left column below. Check the corresponding POSSIBLE CAUSE and CORRECTIVE ACTION columns to remedy the problem.

SYMPTOM	POSSIBLE CAUSE	CORRECTIVE ACTION
No power.	<ul style="list-style-type: none"> • AC Power cord is not connected. • Power is off. 	<ul style="list-style-type: none"> • Connect AC power cord to AC outlet. • Press POWER button to turn on the TV/VCR.
No picture and sound.	<ul style="list-style-type: none"> • TV/VCR is not plugged into an active AC outlet. • Antenna is not connected. • No channel in memory. 	<ul style="list-style-type: none"> • Plug power cord into an active AC outlet. • Check antenna connection. • Program tuner's memory.
No picture or poor picture on TV/VCR.	<ul style="list-style-type: none"> • Direction or condition of antenna is not adequate. • Picture control is not adequate. 	<ul style="list-style-type: none"> • Adjust direction or replace antenna. • Adjust picture controls.
No sound or poor sound.	<ul style="list-style-type: none"> • Volume control on remote control unit or main unit is in minimum position. • MUTE button on the remote control unit is in the ON position. 	<ul style="list-style-type: none"> • Adjust volume control on remote control unit or set. • Press MUTE button.
Timer recording is not possible.	<ul style="list-style-type: none"> • The timer recording is set incorrectly. • The timer recording is not set to ON. 	<ul style="list-style-type: none"> • Set the timer recording correctly. • Set the timer recording to ON.
Cannot go into Record mode.	<ul style="list-style-type: none"> • The erase-prevention tab on cassette is missing. 	<ul style="list-style-type: none"> • Place transparent tape over missing erase-prevention tab.
Playback picture is partially noisy.	<ul style="list-style-type: none"> • The TRACKING control is not set correctly. 	<ul style="list-style-type: none"> • Adjust TRACKING control for better picture.
Noise in picture on playback.	<ul style="list-style-type: none"> • Video heads are dirty. 	<ul style="list-style-type: none"> • Head cleaning is necessary, consult the nearest Sears Service Center.
No operation by infrared Remote Control.	<ul style="list-style-type: none"> • No power to TV/VCR. • Weak batteries. 	<ul style="list-style-type: none"> • Make sure the AC cord is connected to an AC outlet. • Check the batteries in the Remote Control.

CLOSED CAPTION PROBLEM	POSSIBLE REMEDY
My TV/VCR is showing captions that are misspelled.	You are watching a live broadcast and spelling errors made by the closed captioning production company may pass through uncorrected. A prerecorded program will not show any misspelled words because of the normal time available for editing the captions.
My TV/VCR will not show the text in its entirety or there is a delay of what is being said.	Captions that are delayed a few seconds behind the actual dialogue are common for live broadcasts. Most captioning production companies can display a dialogue to a maximum of 220 words per minute. If a dialogue exceeds that rate, selective editing is used to insure that the captions remain up-to-date with the current TV/VCR screen dialogue.
My captions are scrambled with white boxes on the TV/VCR screen.	Interference caused by building, power lines, thunderstorms, etc. may cause scrambled or incomplete captions to appear.
My program guide listed a TV show as being closed captioned but none of the captions were displayed.	Broadcasters may at times use a time compression process to speed up the actual program so that additional advertising time can be given. Since the decoder cannot read the compressed information, captions will be lost.
My prerecorded video tape does not show any captions. The tape box mentions it being closed captioned.	The video tape was either an illegal copy or the tape duplicating company accidentally left out the captioning signals during the copying process.
My TV screen shows a black box on certain channels.	You are in the TEXT mode. Select CAPTION mode or CLOSED CAPTION [OFF].

MAINTENANCE

SERVICING

- Should your TV/VCR become inoperative, do not try to correct the problem by yourself. There are no user-serviceable parts inside. Turn off, unplug the power cord, and take the unit to the nearest Sears Service Center for servicing.

CABINET CLEANING

- Wipe the front panel and other exterior surfaces of the TV/VCR with a soft cloth immersed in lukewarm water and wrung dry.
- Never use a solvent or alcohol. Do not spray insecticide liquid near the TV/VCR. Such chemicals may cause damage and discoloration to the exposed surfaces.

HEAD CLEANING

- Picture playback may become blurred or interrupted while the TV program reception is clear. This does not mean that the recorded program has been erased. Dirt accumulated on the video heads after long periods of tape playback, or the usage of rental or worn tapes can cause this problem. In this case, video head cleaning requires highly technical attention, therefore consult the nearest Sears Service Center. Clean heads only when problems occur.

SPECIFICATIONS

GENERAL SPECIFICATIONS

CRT :	13 inch in-line gun,
	90° deflection tube
Television system :	NTSC-M
Closed caption system :	§15.119/FCC
Video Heads :	Rotary four-head
Tape width :	1/2 inch
Tape speed	
SP :	33.40mm/sec.
LP :	16.67mm/sec.
SLP :	11.12mm/sec.
Tuner channel	
TV VHF Low :	#2~#6
TV VHF High :	#7~#13
TV UHF :	#14~#69
CATV	
VHF :	5A
MID band :	A5~A1, A~I
SUPER band :	J~W
HYPER band :	W+1~W+84
Terminals	
Antenna input :	VHF/UHF 75 ohms unbalanced
Video input :	RCA connector X 2
Audio input :	RCA connector X 2
Earphone :	1/8" monaural (3.5 mm)

ELECTRICAL SPECIFICATIONS

Video input level :	0.5~2.0V _{p-p}
Audio input level :	-15dBs
Video S/N ratio :	More than 46dB
Audio S/N ratio :	More than 43dB

OTHER SPECIFICATIONS

Power requirement :	AC 120V/60Hz
Power consumption :	70W
Dimensions :	H : 15-3/4" (400mm) W : 14-15/16" (379mm) D : 14-3/4" (375mm)
Weight :	26.4 lbs (12.5 kg)
Accessories :	Remote Control 2 "AA" Batteries Matching Adapter VHF/UHF Dipole Antenna Owner's Manual

- Designs and specifications are subject to change without notice and without our legal obligation.

**WE WILL USE THE SEARS
ARTWORK !!!**

111-55-04-445

WARRANTY

TV/VCR COMBINATION

LIMITED WARRANTY

This product is exclusive to and is warranted solely by Sears. For 90 days from the date of purchase, Sears will repair any defect in material or workmanship in this TV/VCR combination, free of charge. For one year from the date of purchase, Sears will supply, at no charge, replacement for defective parts.

This above warranty coverage applies only to TV/VCR combinations which are used for private household purposes.

LIMITED WARRANTY ON PICTURE TUBE

After one year from the date of purchase and up to two years, Sears will furnish, free of charge, a replacement for the picture tube, if defective. You pay for labor.

Warranty service is available by returning the TV/VCR combination to the nearest Sears Service Center/Department in the United States. This warranty applies only while this product is in use in the United States. For service after the warranty expires, it is recommended that this product be returned to the nearest Sears Service Center.

This warranty gives you specific legal rights, and you may also have other rights which vary from state to state.

Sold by Sears, Roebuck and Company, Dept.817WA
Hoffman Estates, IL 60179

PUT ZENITH LOGO

**OWNER'S
MANUAL**

**MODEL NO.
SRV1304S**

OEMN01000
B5607UH ★★★★★

Printed in Malaysia