

CC437

USER'S GUIDE

S-57-04-834

TRON



CAMCORDER

Important Safety Information

Be sure to read all the safety information before you begin to use this product.

WARNING: To reduce the risk of fire or shock hazard, do not expose product or AC adapter/charger to rain or moisture.

CAUTION

RISK OF ELECTRIC SHOCK
DO NOT OPEN



This symbol indicates "dangerous voltage" inside the product that presents a risk of electric shock or personal injury.

ATTENTION

RISQUE DE CHOC
ELECTRIQUE NE PAS OUVRI



This symbol indicates important instructions accompanying the product.

TO REDUCE THE RISK OF ELECTRIC SHOCK, DO NOT REMOVE THE COVER (OR BACK). NO USER-SERVICEABLE PARTS ARE INSIDE. REFER SERVICING TO QUALIFIED SERVICE PERSONNEL.

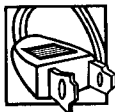

CAUTION: To prevent electric shock, match wide blade of plug to wide slot, fully insert.

ATTENTION: Pour éviter les chocs électriques, introduire la lame la plus large de la fiche dans la borne correspondante de la prise et pousser jusqu'au fond.

To reduce risk of injury, charge only rechargeable batteries recommended by the manufacturer for this camcorder. Other types of batteries may burst causing damage and personal injury.

CAUTION: Avoid operating this product immediately after moving it from a cold location to a warm location. Give it 2 to 3 hours to reach a stable temperature before inserting a video cassette. When moved from a cold area to a warm location, moisture may condense on the head drum inside the machine. This moisture could cause the tape to stick to the headwheel and damage the headwheel or tape.

FCC Regulations state that unauthorized changes or modifications to this equipment may void the user's authority to operate it.

Product Registration

Please fill out the product registration card and return it immediately. Returning this card allows us to contact you if needed.

Keep your sales receipt for proof of purchase to obtain warranty parts and service and attach it here. Record the serial and model numbers located on the bottom of the product.

Model CC437

Serial No: _____

Purchase Date: _____

Purchased From: _____

Assistance

We want to make sure you enjoy your new camcorder. If you have any questions, call:

Customer Service..... 800-336-1900 (Page 67)

Accessories..... 800-338-0376 (Pages 54-61)

Table of Contents

Safety Information.....i	Powering the Camcorder
Product Registration.....i	• Using the Adapter/Charger10
Contents.....1-2	• Using the Rechargeable Battery
First-Time Operation	• Charging11
• Assistance.....3	• Attaching and Removing.....12
• Unpack Camcorder and	• Care and Storage13
Accessories3	• Safety Precautions13
• Attach the Adapter/Charger4	• Battery Level Indicator.....14
• Remove Lens Cap and Attach	• Using the Optional Thomson
to Handstrap.....5	Car Cord Adapter.....15
• Turn on the Camcorder5	Video Cassettes
• Insert a Cassette6	• Erase Protection.....16
• Position Viewfinder and	• Recording and Playback Times.....16
Adjust Eyepiece Focus Control6	• Inserting and Removing
• Start and Stop Recording7	Cassettes.....17
• Play Back What You Have	Cassette Care and Storage.....17
Recorded7	Traveling Tips18
• Review the Camcorder's	Cassette Tips18
Operating Controls8-9	

Table of Contents

Recording Features		Recording on the Camcorder42-43	
• Quick Review.....	19		
• Tape Positioning	19		
• Microphone	19		
• AI (Artificial Intelligence)	19		
• Program AE (Auto Exposure).....	20		
• Auto Focus	20		
• Macro Focus.....	20		
• Electronic Indexing	21		
• Time Remaining Display	21		
• Viewfinder	22-23		
• Displays in Viewfinder	24-25		
• Date and Time Display			
• Set the Date and Time	26		
• Record the Date and Time (or Date) on Your Tape	27		
• Charging the Clock Cell	27		
• Zooming			
• Power Zoom Buttons.....	28		
• Instant Zoom	29		
• Digital Zoom	29		
• 16 x 9 Mode.....	30		
• Fading In and Out of Scenes	31		
• Tape Counter with Memory Stop.....	32		
• ProEdit® Features			
• Flying Erase Head	33		
• Edit Search	33		
• Audio Dubbing.....	34-35		
• Audio/Video Dubbing.....	36-37		
• <i>Titler</i>	38-40		
Recording Tips	41		
		Playback	
		• Viewfinder Playback	44
		• Playback Features	
		• Stop-Action Pause.....	44-45
		• Picture Search	44-45
		• Tracking	45
		• Playback on TV (or VCR) with <i>AUDIO/VIDEO IN</i> Jacks	46-47
		• Playback on TV without Audio and Video Inputs.....	48-49
		Color Enhancement Light	50-51
		Attaching the Shoulder Strap	52
		Packing Carrying Case	53
		Information to User	53
		Specifications	54
		Optional Accessories	54-61
		• Accessory Order Form.....	59-61
		Care and Maintenance	62-63
		Trouble Checks	64-66
		Limited Warranty	67
		Index (Alphabetical)	68-69

First-Time Operation

This section describes only the basic steps necessary to set up your camcorder to record. Refer to the other sections for detailed operation and feature options.

Assistance

The toll-free numbers are available to help you with any problem you may encounter.

Customer Service800-336-1900

Accessories800-338-0376

1. Unpack the camcorder and accessories.

- Save the box and packing materials in case you ever need to store or ship your camcorder.
- The items shown below are packed with your camcorder. If any of them are missing or appear damaged, contact your dealer immediately.

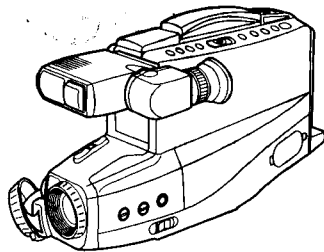

Camcorder
Model CC437

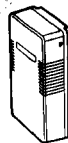

**WARNING: LEAD-
ACID BATTERY.
MUST BE DISPOSED
OF PROPERLY.**

Rechargeable 10-Volt Battery
Stock No. EP096FS



Shoulder Strap
Stock No. 227327

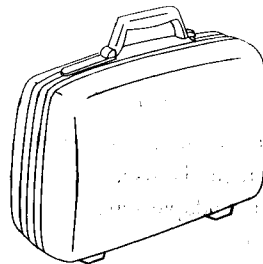

Carrying Case
Part No. 233110

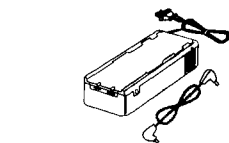

AC Adapter/Charger: Stock No.
232595

DC Cable: Stock No. 209342

Caution: Do not use this adapter/charger for any purpose other than charging the EP096FL or EP096FS battery pack or supplying power to the camcorder.

First-Time Operation

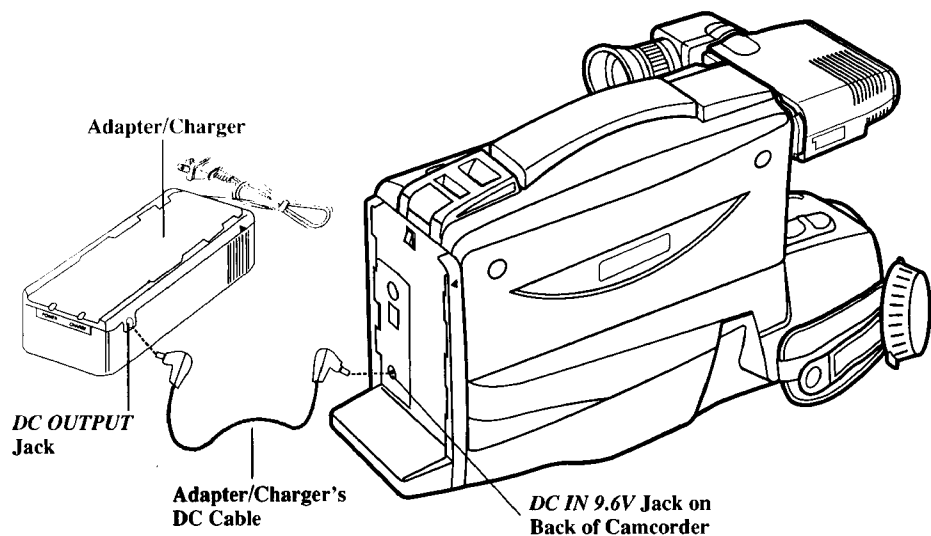

2. Attach the adapter/charger.

Since the battery must be charged before it can be used the first time, attach the adapter/charger to the camcorder.

- Attach one end of the adapter/charger's DC cable to the *DC OUTPUT* jack on the adapter/charger.
- Attach the other end of the cable to the *DC IN 9.6V* jack on the camcorder.
- Plug the adapter/charger's plug into an operating outlet.
- *Details are on page 10.*

First-Time Operation

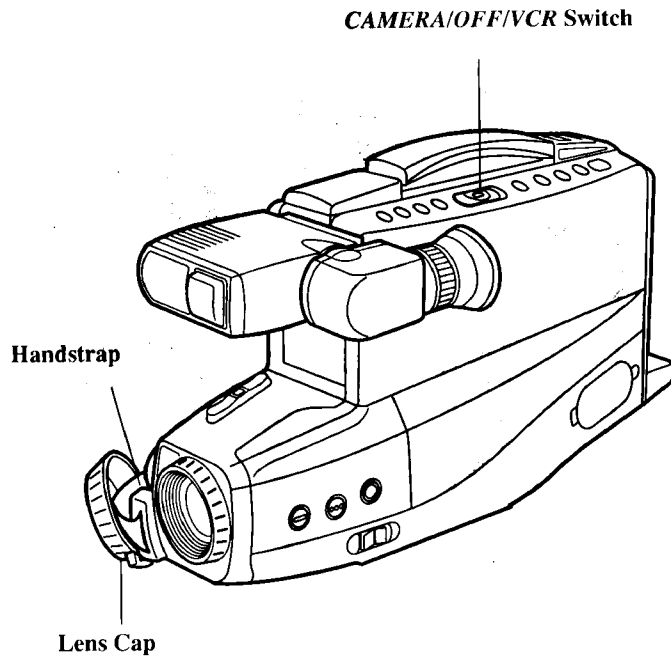

3. Remove the lens cap and attach it to the handstrap.

4. Turn on the camcorder.

The position of the *CAMERA/OFF/VCR* switch tells the camcorder whether you want to record (*CAMERA*), play back tapes (*VCR*), or turn off the power (*OFF*).

- Press and hold the small button on *CAMERA/OFF/VCR* while sliding it in *CAMERA*. The electronic viewfinder will come on.

First-Time Operation

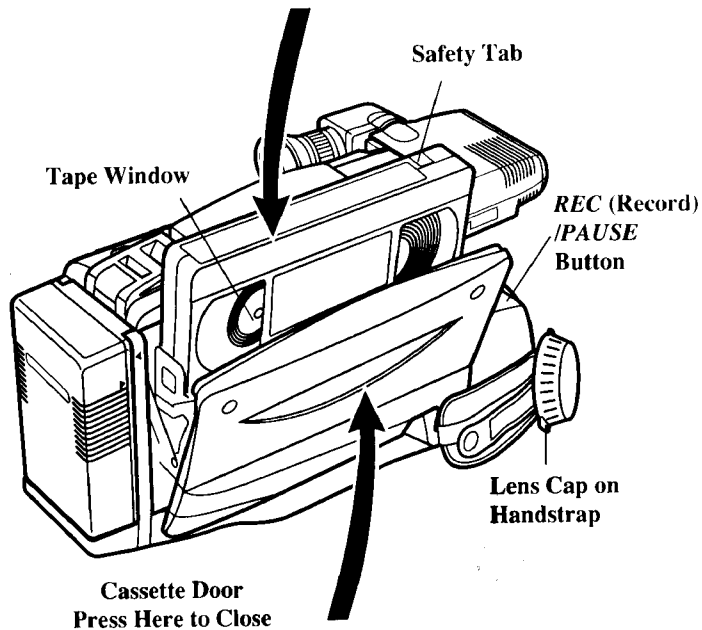

5. Insert a cassette.

- Press *STOP/EJECT* to open the cassette compartment.
- Insert the cassette with the safety tab facing up and the tape windows facing out.
- Press the cassette down gently until it locks into place, and close the cassette compartment door.
- *Details are on page 17.*

6. Position viewfinder and adjust eyepiece focus control.

- Grasp the viewfinder and rotate it horizontally.
 - Pull the viewfinder out from the camcorder and rotate the eyepiece into a comfortable viewing position.
- Caution:** Pulling on the eyepiece may cause damage to the eyepiece or camcorder.
- If the image in the viewfinder is blurry, adjust the eyepiece focus control for your vision. *Details are on page 22.*

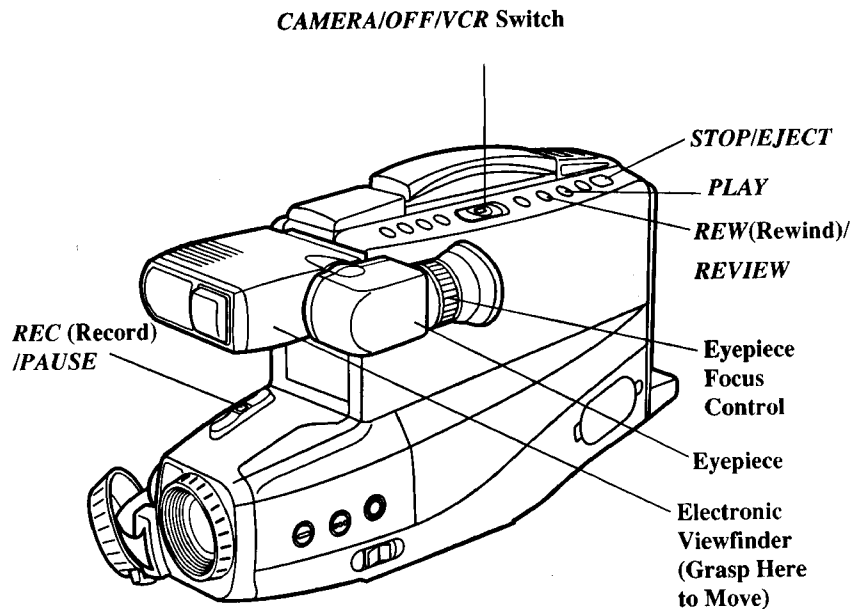

7. Start and stop recording.

Start and stop recording by pressing and releasing **REC/PAUSE**. **REC** appears in the viewfinder. You do not have to hold the button to record.

Notes: If you do not record within five minutes, the camcorder will automatically shut off to prevent excessive tape wear. Press **REC/PAUSE** to turn on the camcorder.

Any material recorded on the tape will automatically be erased if you record over it.

8. Play back what you have recorded.

- Press **REC/PAUSE** to stop recording.
- Press and hold the small button on **CAMERA/OFF/VCR** while sliding it to **VCR**.
- Press **REW(rewind)/REVIEW** to rewind the tape.
- Press **PLAY** to play back the tape in the viewfinder.
- Press **STOP/EJECT** when you are finished playing back the tape.
- *Details on viewfinder playback are on page 44.*

First-Time Operation

9. Review the camcorder's operating controls.

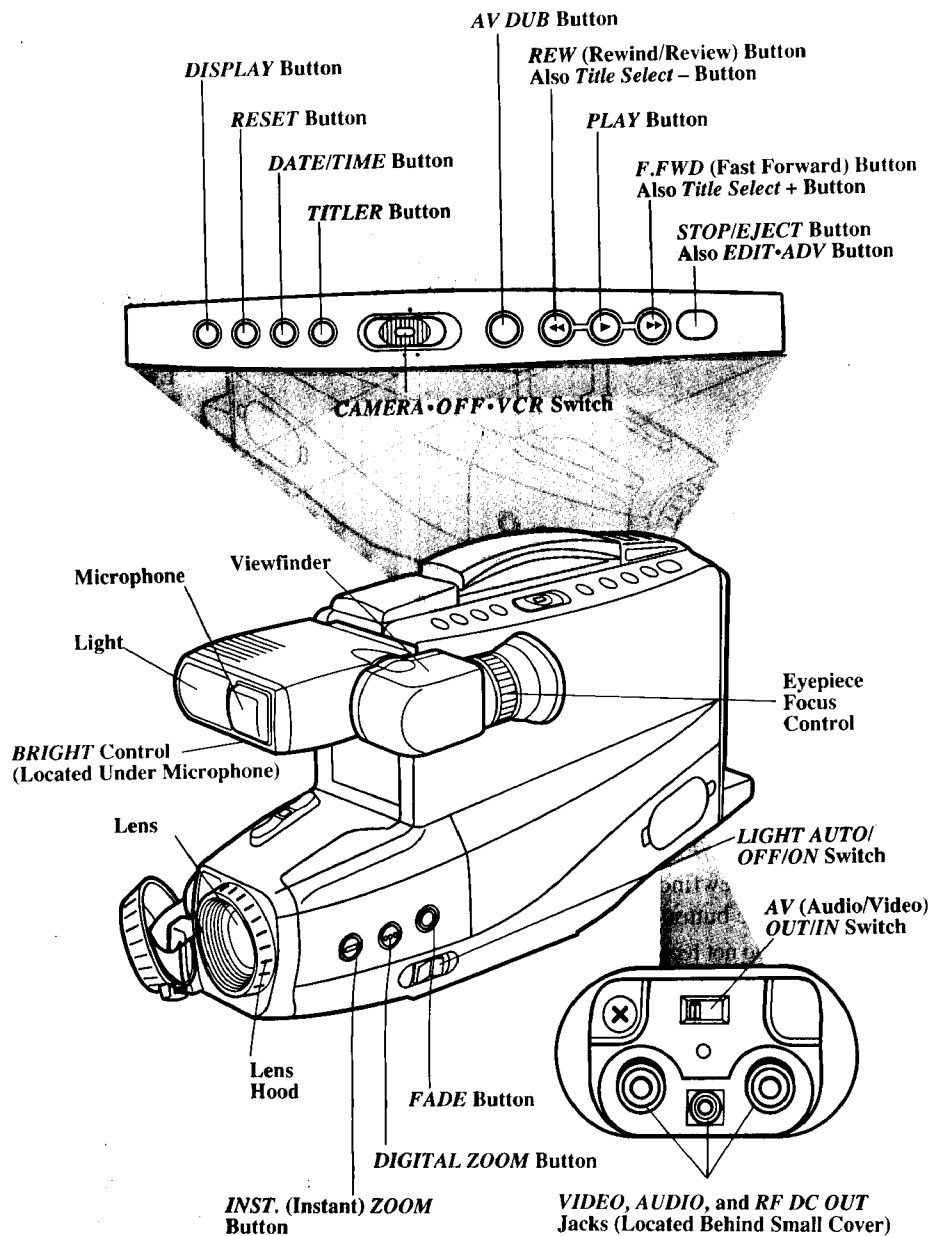

First-Time Operation

9. Review the camcorder's operating controls.

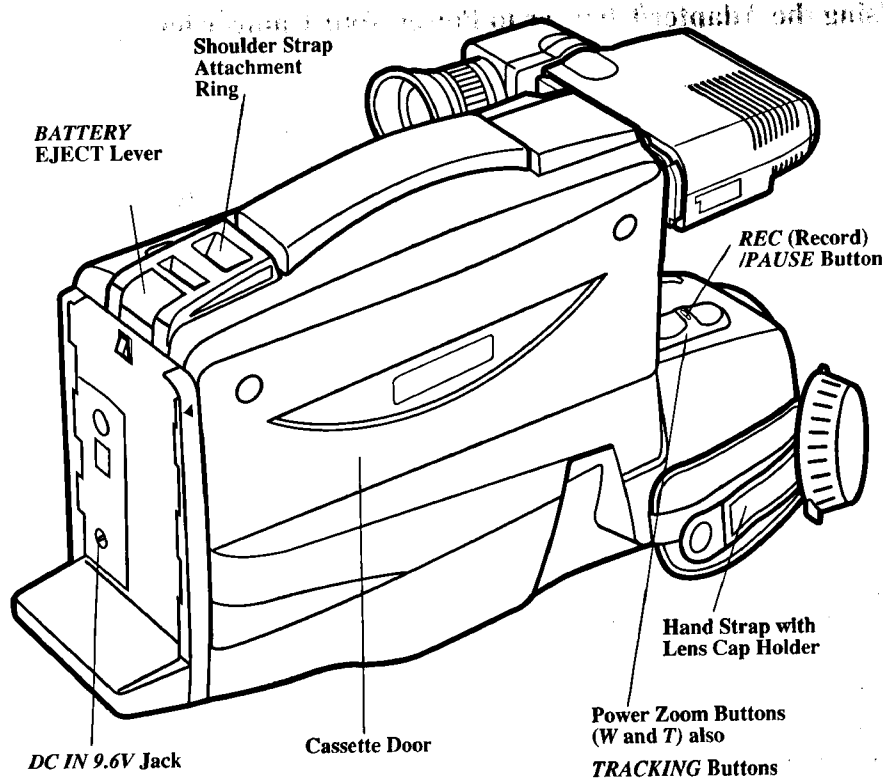

Powering the Camcorder

Caution: Do not attempt to use a "power converter" to use your AC adapter/charger on a power source other than 120 volts, 50/60 Hz, or the adapter/charger and camcorder may be damaged. If you wish to operate the AC adapter/charger on a power source other than 120 volts, 50/60 Hz, use only a transformer-type power converter. Do not use "solid-state" or "switching-type" power converters. They will damage your AC adapter/charger. An optional CPS014 shown on page 55 is designed for use on 100-240 volts, 50/60 Hz.

Using the Adapter/Charger to Power Your Camcorder

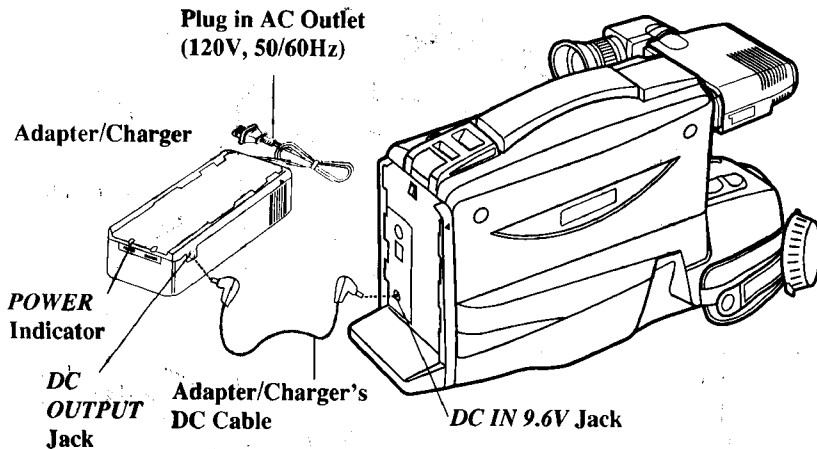

1. Connect one end of the adapter/charger's cable to the adapter/charger's DC OUTPUT jack and the other end to the DC IN 9.6V jack on the back of the camcorder.
2. Plug the adapter/charger into the nearest AC outlet (120V, 50/60 Hz).
3. The POWER indicator on the adapter/charger will light when it is properly connected.

Notes: The adapter/charger cannot charge the battery and operate the camcorder at the same time. If you connect both, the adapter/charger will power the camcorder. Remove the adapter/charger's cable from the DC OUTPUT jack to charge the battery.

When using the adapter/charger to power the camcorder, the battery level indicator may display . This indicator is used for battery operation and has no meaning when using the adapter/charger to power the camcorder.

To Remove the Adapter/Charger

1. Remove the adapter/charger's plug from the AC outlet.
2. Remove the adapter/charger's DC cable from the DC IN 9.6V jack on the camcorder.

Caution: Do not use this adapter/charger for any purpose other than charging the EP096FS or EP096FL battery pack or supplying power to the camcorder.

Powering the Camcorder

Using the Battery to Power Your Camcorder

Charging the Battery

The battery must be charged before it can be used the first time. Charging will take approximately two hours depending on the condition of the battery. When fully charged, the battery should supply approximately 60 minutes of operating time (depending on how much you use zoom and pause). To extend the battery's operation time, turn off the camcorder's power when not in use.

Plug in AC Outlet
(120 V, 50/60 Hz)

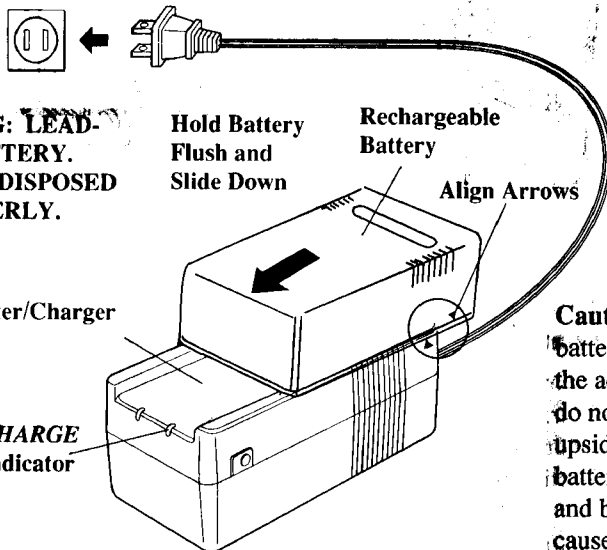

WARNING: LEAD-ACID BATTERY. MUST BE DISPOSED OF PROPERLY.

Hold Battery
Flush and
Slide Down

Rechargeable
Battery

Align Arrows

Caution: When a battery is attached to the adapter/charger, do not turn them upside down. The battery may fall off and be damaged or cause injury.

1. Attach the battery to the adapter/charger as shown. Align the reference arrow on the battery with the arrow on the adapter/charger. Hold the battery flush against the adapter/charger and slide it in the direction of the arrow.
Note: You cannot charge the battery and operate the camcorder from the adapter/charger at the same time. Remove the adapter/charger's DC cable from the camcorder to charge the battery.
2. Plug the adapter/charger into the nearest AC outlet (120 V, 50/60 Hz).
3. The **CHARGE** indicator will light while the battery is being charged. When the indicator turns off, the battery is fully charged.
4. Remove the battery from the adapter/charger by sliding the battery up and off.
5. Attach the charged battery to the camcorder *as shown on the next page.*

Powering the Camcorder

Using the Battery to Power Your Camcorder

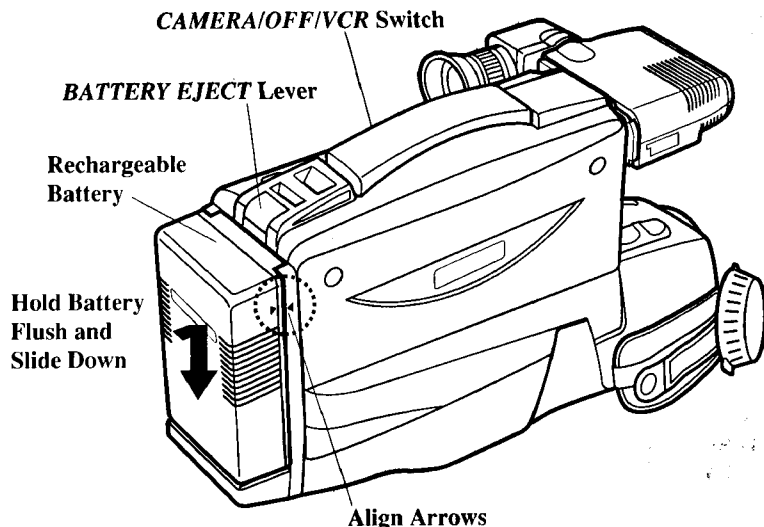

Attach Charged Battery

1. Align reference arrow on battery with arrow on camcorder. Hold battery flush against camcorder while sliding it down in the direction of the arrow as shown.
2. Press and hold small button on *CAMERA/OFF/VCR* while placing it in *CAMERA*.

Remove the Battery

1. Slide *CAMERA/OFF/VCR* to *OFF*.
2. Press and hold *BATTERY EJECT* while sliding battery up and off the camcorder.

ATTENTION: LEAD-ACID BATTERY MUST BE DISPOSED OF PROPERLY. THE PRODUCT THAT YOU HAVE PURCHASED USES A RECHARGEABLE BATTERY. AT THE END OF ITS USEFUL LIFE, UNDER VARIOUS STATE AND LOCAL LAWS, IT MAY BE ILLEGAL TO DISPOSE OF THIS BATTERY INTO THE MUNICIPAL WASTE STREAM. CHECK WITH YOUR LOCAL SOLID WASTE OFFICIALS FOR DETAILS IN YOUR AREA FOR RECYCLING OPTIONS OR PROPER DISPOSAL.



Pb

Powering the Camcorder

Using the Battery to Power Your Camcorder

Battery Care

- Your battery will provide better service and longer performance if you charge it before and after use, and store it at normal room temperature.
- The battery should be charged at a temperature of 32°F-95°F (0°C-35°C) to prevent damage.
- Do not operate the battery at temperatures below 14°F (-10°C) or above 95°F (35°C). The battery may be damaged if operated at temperatures above 122°F (50°C). Operation time will decrease at extremely low temperatures.
- After repeated chargings and use, the operation time will gradually decrease. When operation time becomes too short to be useful, it is time to replace the battery.

Battery Storage

- Store the battery at normal room temperature.
- Lead acid batteries discharge if not used. Recharge the battery at least once every six months or you may not be able to recharge it.
- A battery stored for a long period may not supply power for the specified time. Additional rechargings may help restore the battery's operation time.

Battery Safety Precautions

Batteries being recharged that have not been used for an extended period may continue to charge after the normal time. Do not charge a battery for more than 24 hours.

If both indicators on the adapter/charger start flashing, remove the battery, and reattach it. If after several attempts — the indicators continue to flash — your battery cannot take a charge and must be replaced.

Throwing the battery into a fire or exposing the battery to excessive heat — over 149° F (65° C) could be hazardous.

Do not short the battery's terminals.

Allow battery to cool down before attaching it to adapter/charger. The *CHARGE* indicator will not light and the battery will not charge if you attach a hot battery.

Do not attempt to disassemble or modify the battery. There are no user-serviceable parts inside.

Use the battery only with specified AC adapter/chargers and camcorders.

If leakage from a damaged battery contacts your skin or clothing, wash it off immediately with running water.

Powering the Camcorder

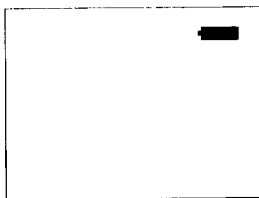

Check Battery Power (Battery Level Indicator)



**Battery Level Indicator
Display in Viewfinder**

When *DISPLAY* is pressed, the battery level indicator () appears in the camcorder's viewfinder to show how much battery power is left in the rechargeable battery.

This indicator is not recorded on the tape.

- When the battery is fully charged, the display shows .
- After a while, only  appears.

- When the battery reaches the empty level,  will start flashing. Recharge the battery or attach the adapter/charger before continuing to use the camcorder.

Notes: The battery level indicator has no meaning when you power the camcorder with the adapter/charger or optional car cord.

When a rechargeable battery is used to power the camcorder,  flashes even if *DISPLAY* is not pressed to warn you that the battery power level is low.

Caution: When the battery reaches its empty level during use, the camcorder will turn off. However, the battery should have enough reserve power to eject the cassette when you press *STOP/EJECT*.

If the camcorder does not eject the cassette when you press *STOP/EJECT*, **do not force the cassette door open.** This will damage your camcorder.

Before attempting to eject the cassette, power your camcorder with the adapter/charger or recharge the battery.

Powering the Camcorder

Using the Optional Thomson Car Cord Adapter

To power your camcorder from the cigarette lighter socket of a car, truck, or RV, you need the optional car cord adapter DCC096 shown on page 55.

The DCC096 car cord is especially designed to convert power from a 12-volt battery to the 9.6-volt input jack on the camcorder.

Caution: The DCC096 car cord is designed to be used only with vehicles having 12-volt negative ground electrical systems.

Warning: To avoid possible damage to your camcorder, use only the DCC096. It has positive tip polarity and is capable of converting 12-volts to 9.6 volts.

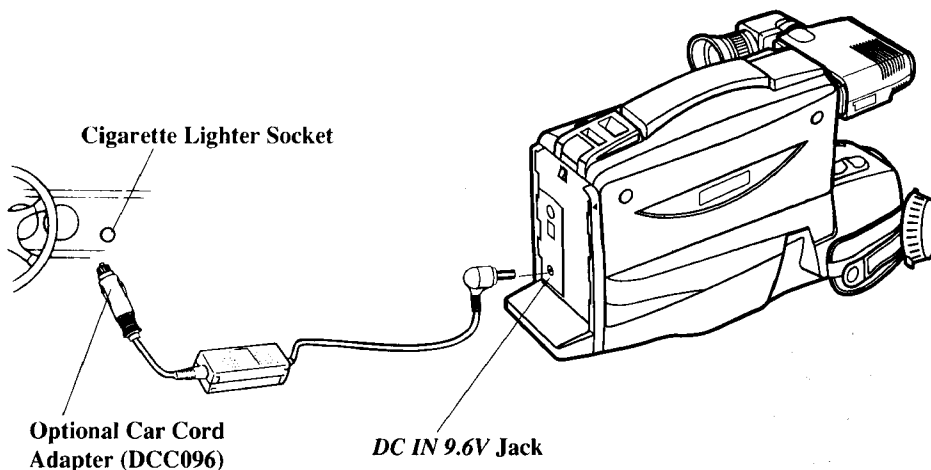

1. Remove the adapter/charger's DC cable or battery from the camcorder, if either is attached.
2. Connect the small plug on the car cord to the DC IN 9.6V jack located on the back of the camcorder.
3. Insert the other end of the car cord into the vehicle's cigarette lighter socket.
4. Place the camcorder's CAMERA/OFF/VCR switch in CAMERA. If the car cord is connected properly, the electronic viewfinder will come on.

Notes: The vehicle does not have to be turned on for the camcorder to operate from the DC car cord.

When using the car cord to power the camcorder, the battery level indicator may display . This indicator is used for battery operation and has no meaning when using the car cord to power the camcorder.

Video Cassettes

We recommend that our cassettes be used with your camcorder. Use of poor quality tapes or tapes that have been damaged or mishandled can contaminate the video heads, resulting in a snowy picture or no picture at all during playback. Because there is no control over the type of tape purchased or rented by consumers, **head cleaning is not covered under warranty**. It is considered normal maintenance.

If a snowy picture or no-picture condition persists, consider the use of a dry chemical non-abrasive head-cleaning tape. Be sure to follow the directions with the head-cleaning kit carefully. Improper use of a head cleaner may damage your camcorder.

Erase Protection — Safety Tab

You can use your video cassettes over and over again. To erase a previous recording, just record over it.

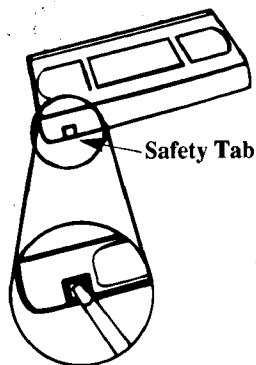

To prevent accidental erasure, break the tab.

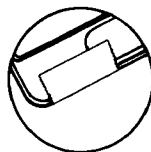

To record again, cover the hole with vinyl tape.

Recording and Playback Times

The camcorder records and plays back in VHS standard speed (SP). The chart shows the maximum SP recording times for popular VHS cassettes.

CASSETTE	RECORDING TIME
T-60	60 Min.
T-120	2 Hrs.
T-160	2 Hrs., 40 Min.
T-180	3 Hrs.

Video Cassettes

Inserting and Removing Cassettes

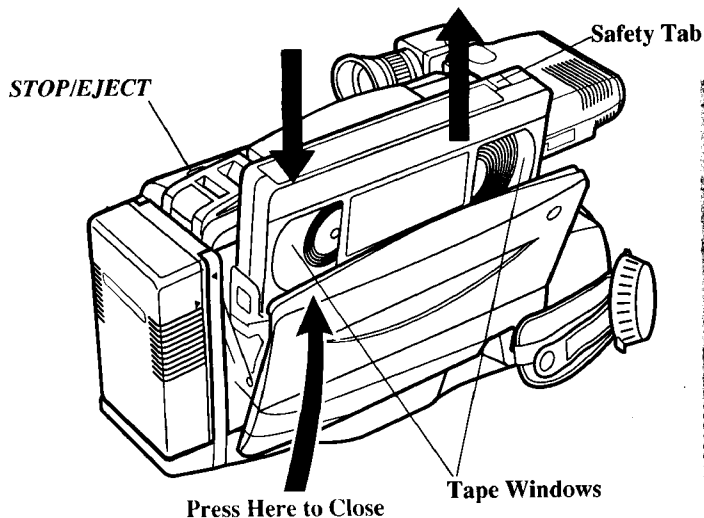

Caution: Insert cassette with safety tab facing up and tape windows facing out. Cassette should slide easily into the compartment. Gently push the cassette down until it locks into place.

1. Attach a power source to the camcorder (either a charged battery or adapter/charger).
2. Press *STOP/EJECT* on the top of the camcorder to open cassette door.
3. Insert or remove the cassette from the cassette compartment.
4. Gently close the cassette door with your hand.

Cassette Care and Storage

Follow these directions for continued high-quality performance from your cassettes.

- When you are finished with a cassette, rewind it and remove it from the camcorder.
- Label and store cassettes vertically in their protective cases at normal room temperatures. Excessive heat or cold may damage your cassettes.
- Keep dust from entering the cassette compartment. All dust is abrasive and will cause excessive wear on the tape and the camcorder's recording or playback heads.
- Keep cassettes away from strong magnetic fields, such as electric motors and other devices.
- Do not use a cassette if it has been damaged or exposed to moisture. The tape may jam or damage the camcorder.
- When you are finished recording, break off the safety tab on the cassette to prevent accidental erasure.
- Do not leave your camcorder or cassettes in a car or outdoors for an extended period. Excessive heat or cold may damage them.

Camcorder Traveling and Cassette Tips

Traveling Tips

Write down your camcorder's serial number and keep it separate from the camcorder when traveling. If your camcorder is lost or stolen, you will be able to identify it.

Make sure you have any plug adapters you need before taking your camcorder to other countries. Consult your dealer.

Use extra care to avoid damage to your camcorder and accessories when operating them at a beach or pool. Spray, sand, and dust should be avoided. If your lens has been exposed to the elements, clean it only with proper lens cleaning supplies.

Carry your camcorder in a carrying case when traveling. See page 54 for a specially designed soft case. An ordinary suitcase or carry bag does not offer the protection your camcorder needs. Treat your camcorder as carry-on luggage to protect it from rough handling.

Cassette Tips

Do not use a cassette if it has been damaged or exposed to moisture. The tape may jam or damage your camcorder.

When you are finished recording, break off the safety tab on the cassette to prevent accidental erasure.

Label your cassettes before storing them.

Store your cassettes vertically in their protective cases at normal room temperature.

Do not leave your camcorder or cassettes in a car or outdoors for an extended period. Excessive heat or cold may damage them.

Camcorder Features

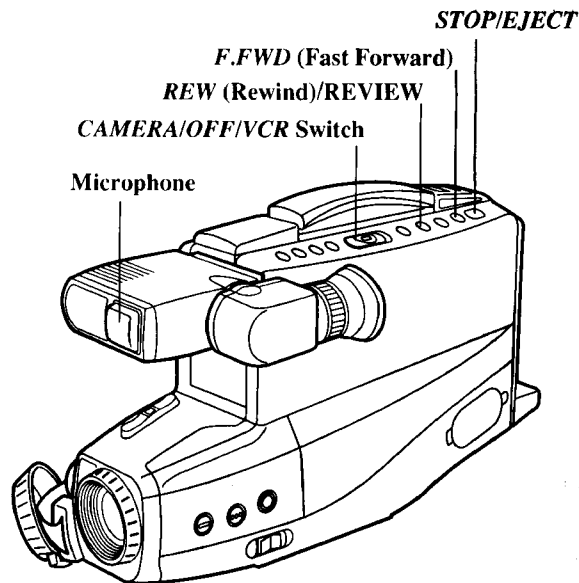

Quick Review

Press **REW/REVIEW** when **CAMERA/OFF/VCR** is in **CAMERA** and the camcorder is in record pause to review the last few seconds of a recording.

The camcorder will play back the last few seconds of the recording, return the tape to its previous position, and return to record pause.

Tape Positioning

When **CAMERA/OFF/VCR** is in **VCR** and the camcorder is in the stop mode, you can quickly fast-forward or rewind the tape.

- Press **F.FWD** (fast forward) to fast forward the tape. Press **STOP/EJECT** to stop fast-forwarding.

- Press **REW/REVIEW** to rewind the tape to the beginning. Press **STOP/EJECT** to stop rewinding.

Microphone

The microphone picks up sound during a recording. It is more sensitive to sounds coming from the direction the lens is pointed.

AI (Artificial Intelligence)

The camcorder will automatically adjust focus, white balance and iris according to the recording conditions.

Camcorder Features

Program AE (Auto Exposure)

Program auto exposure automatically selects the shutter speed and adjusts the iris according to the shutter speed.

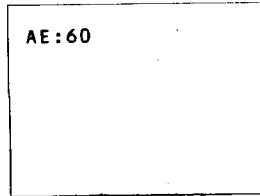

Viewfinder Display

When *DISPLAY* is pressed, the AE indicator for the shutter speed selected (*1/60, 1/100, 1/120, 1/180, 1/250, 1/350, 1/500, 1/750, 1/1000, 1/1500, 1/2000, or 1/4000* second) appears in the viewfinder.

Auto Focus

The camcorder will focus on the subject in the center of the viewfinder.

Auto focus operates on the telephoto “*T*” side from approximately 3.6 feet to infinity and on the wide-angle “*W*” side $3/8$ of an inch from the lens surface to infinity.

The following conditions may prevent auto focus from operating properly.

- Subject has close foreground and background far away.
- Two subjects at different distances that overlap.
- Subject with distinct horizontal stripes or small pattern.
- Subject not in center of the viewfinder.
- Subject with shiny surfaces or sharp angles.
- Recording in low-light situations.
- Recording through a window.

Macro Focus

The macro-focus feature lets you focus on objects as close as $3/8$ of an inch from the camcorder lens.

1. Press and hold zoom button “*W*” until the lens is completely zoomed out.
2. Position the subject in the center of the viewfinder.

Notes: Zooming is not possible when using macro focus. To change the size of the subject, move the camcorder’s lens closer or farther away from it.

For best results, increase illumination when recording using macro focus.

Camcorder Features

Electronic Indexing

Each time you begin recording (after the camcorder has been turned off for at least four hours), the camcorder will automatically record an index mark at the beginning of the new recording.

When you play back the indexed tape in a VCR that has a compatible indexing feature called "VHS Index Search System," the invisible marks can be located automatically. See your VCR owner's manual for index playback instructions.

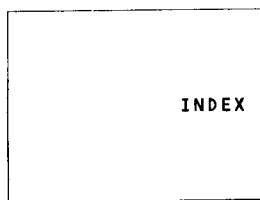

Viewfinder Display

When *DISPLAY* is pressed so the display appears in the viewfinder, *INDEX* will appear briefly to let you know the camcorder is recording an index mark.

Note: The camcorder does not record index marks every time you stop and start recording. An index mark is recorded only once — at the start of each day's recording session (or whenever the camcorder has been turned off for at least four hours).

Time Remaining Display

The time remaining display shows the amount of recording or playback time left on the tape in the camcorder.

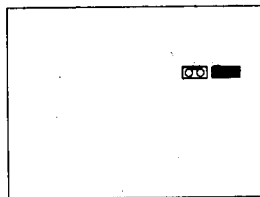

Viewfinder Display

When *DISPLAY* is pressed so the display appears in the viewfinder, "-----" will appear for approximately ten seconds when you first start playing or recording a tape while the camcorder

calculates the time remaining. Once time remaining has been calculated, it will automatically be updated and readily available as long as the same tape remains in the camcorder.

Viewfinder

The camcorder's viewfinder is a miniature monitor that displays the picture seen by the camcorder when recording. The viewfinder also can be used for viewing the tape during playback.

When carrying or storing the camcorder, return the viewfinder to the original position to prevent possible damage.

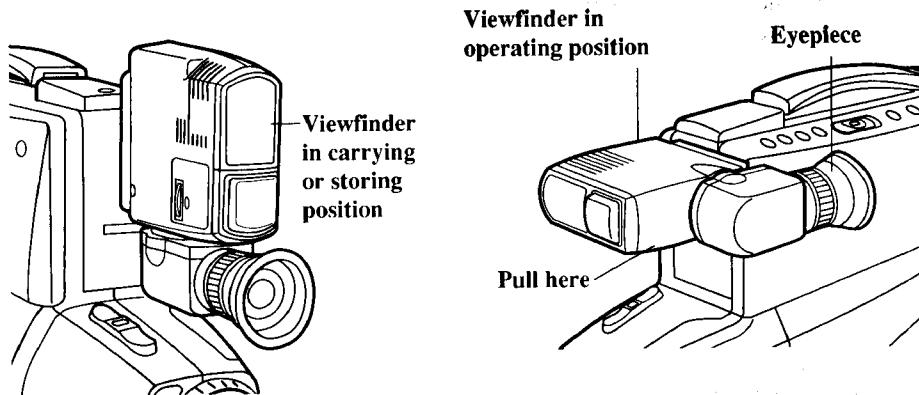

Caution: Pulling on the eyepiece may cause damage to the camcorder.

1. Grasp the viewfinder and rotate it horizontally.
2. Pull the viewfinder out from the camcorder and adjust the eyepiece for convenient viewing.

Eyepiece Focus Control

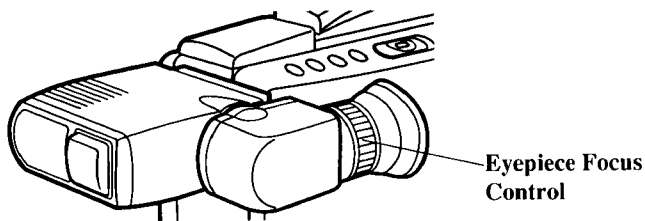

The eyepiece focus control lets you set the focus of the viewfinder for your personal vision. If you wear eyeglasses, you probably can operate the camcorder without them.

Set the correct focus by focusing on one of the viewfinder's displays (such as the

counter). Look through the viewfinder, and adjust the eyepiece focus control for your vision.

The eyepiece focus control does not affect the focus of the picture actually recorded by the camcorder.

Viewfinder

Eyepiece *BRIGHT* Control

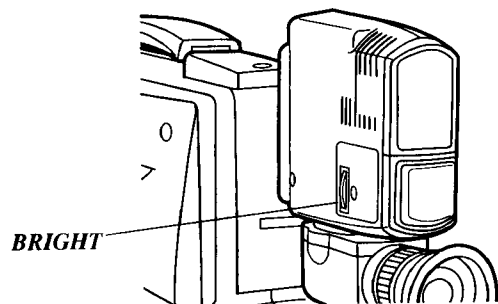

BRIGHT Control

Viewfinder brightness can be adjusted by turning the *BRIGHT* control. This does not affect the picture actually recorded by the camcorder.

Tilt Adjustment

For convenient viewing, you can rotate the eyepiece about 225° degrees.

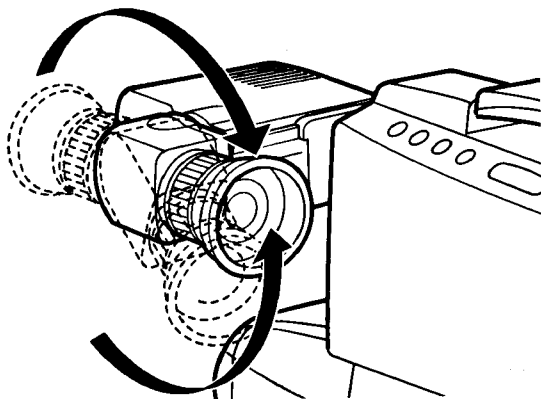

Caution: Do not force the eyepiece to rotate completely around. This will damage the eyepiece and/or the camcorder.

Displays in Viewfinder

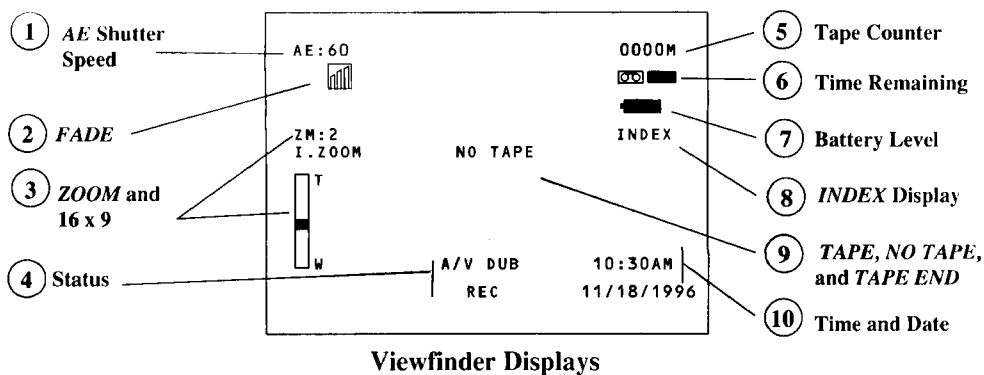



1 AE (Auto Exposure) Shutter Speed

The shutter speed selected by the camcorder appears here. It is not recorded on the tape.

- Press *DISPLAY* to display the shutter speed.

2 Fade

Press *FADE* to select white, wipe, or zoom fade. It is not recorded on the tape.

-  appears for white fade.
-  appears for wipe fade.
-  appears for zoom fade.
- Press *DISPLAY* to display the fade icon.
- *Details are on page 31.*

3 ZOOM and 16 x 9

Press *DIGITAL ZOOM* to select a digital zoom mode. The mode selected appears. It is not recorded on the tape. Press *DISPLAY* to display the zoom and 16 x 9.

- Select *ZM:2* to activate the extended zoom mode — wide angle to 100X.
- Select *16X9* to make a recording that will be played back on a 16 x 9 wide screen TV.

- *ZOOM* appears when you press power zoom button *T* and zoom in the telephoto direction more than 12 times.



- *I.ZOOM* appears when you press *INST.ZOOM* to enlarge the picture 1.5 times.

- The zoom level indicator appears when you press power zoom button *T* or *W*.

- *Details are on pages 28-30.*

4 Status

The following displays appear in this area. They are not recorded on the tape.

- *A/V DUB* for audio/video dubbing.
- *A. DUB* for audio dubbing.
- *REC* for recording.
-  during fast forward.
-  during rewind.
-  during record pause.

5 Tape Counter with Memory Stop (M)

The tape counter helps you locate tape segments. It is not recorded on the tape.

- Press *DISPLAY* to turn memory stop on or off.

Details are on page 32.

Displays in Viewfinder

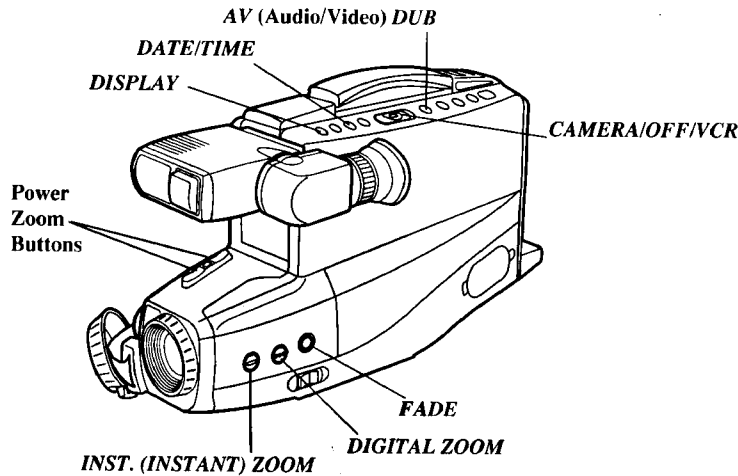

6 Time Remaining ()

This display shows the amount of recording or playback time remaining on the tape. It is not recorded on the tape.

- Press *DISPLAY* to display the time remaining.
- *Details are on page 21.*

7 Battery Level ()

This indicator shows the amount of time left for the rechargeable battery. It is not recorded on the tape.

- Press *DISPLAY* to display the battery level.
- *Details are on page 14.*

8 INDEX

When *DISPLAY* is pressed, the display appears in the viewfinder. *INDEX* appears briefly when the camcorder automatically indexes the tape. It is not recorded on the tape. *Details are on page 21.*

9 TAPE, NO TAPE, and TAPE END

- *TAPE* flashes when you try to record and the safety tab has been removed.
- *TAPE* flashes when a damaged tape is inserted. Remove the tape and replace it with a new one.
- *NO TAPE* flashes when you try to record and there is no cassette in the camcorder.
- *TAPE END* flashes when you have approximately five minutes recording time left on the cassette.
- *TAPE END* briefly appears when you reach the end of the cassette during recording.
- These displays are not recorded when they appear.

10 Time and Date Display

- Press *DATE/TIME* repeatedly to display time and date, *AUTO* date, *TITLE* and date, date only, or no date display when the camcorder is in record pause.
- These displays are recorded when they appear.
- *Details are on pages 26-27.*

Date and Time Display

Set the Time and Date

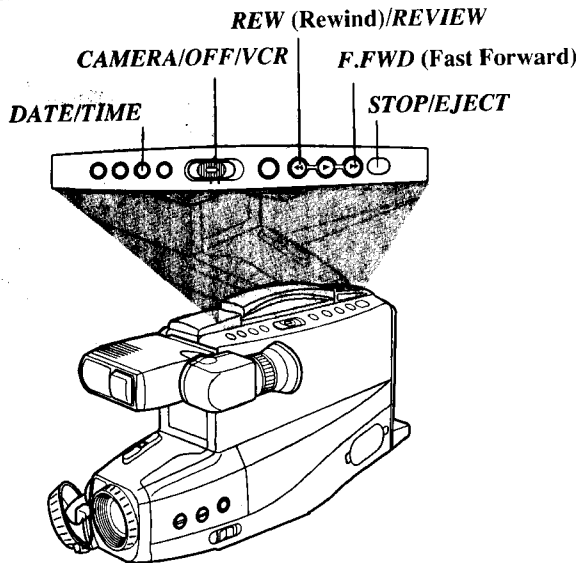

1. Attach a power supply (battery or adapter/charger) to the camcorder.
2. Press and hold the small button on *CAMERA/OFF/VCR* and place in *CAMERA*.
3. Press *DATE/TIME* to display the date and time in the viewfinder. A flashing cursor lets you know which part of the display you are setting.
5. When the correct digit is displayed, press *STOP/EJECT*. The cursor will move to the next part of the display.
6. Repeat steps 4 and 5 to set the correct month, day, year, hour, minute(s), and *AM/PM*.
7. After setting *AM* or *PM*, press *DATE/TIME* to remove the flashing cursor and start the internal clock.

Note: If flashing cursor does not appear, press and hold *DATE/TIME* and then press *STOP/EJECT*.

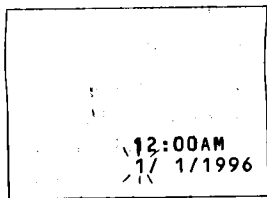

4. Repeatedly press *F.FWD* or *REW/REVIEW* until correct month appears. Press and hold the button to advance the digits faster.

To Correct the Date or Time

To correct the date or time, press and hold *DATE/TIME* and then press *STOP/EJECT*. The display will appear in the viewfinder along with the flashing cursor. Use *F.FWD* and *REW/REVIEW* to correct the time or date. Press *DATE/TIME* to remove the flashing cursor and start the clock.

Date and Time Display

Recording Date and Time, Date, or Date and Title on Your Tape

The time and date, date only, or date and title can be recorded on your tape. Whenever one of the displays appears in the viewfinder, it will be recorded. The camcorder also has auto date and auto title features.

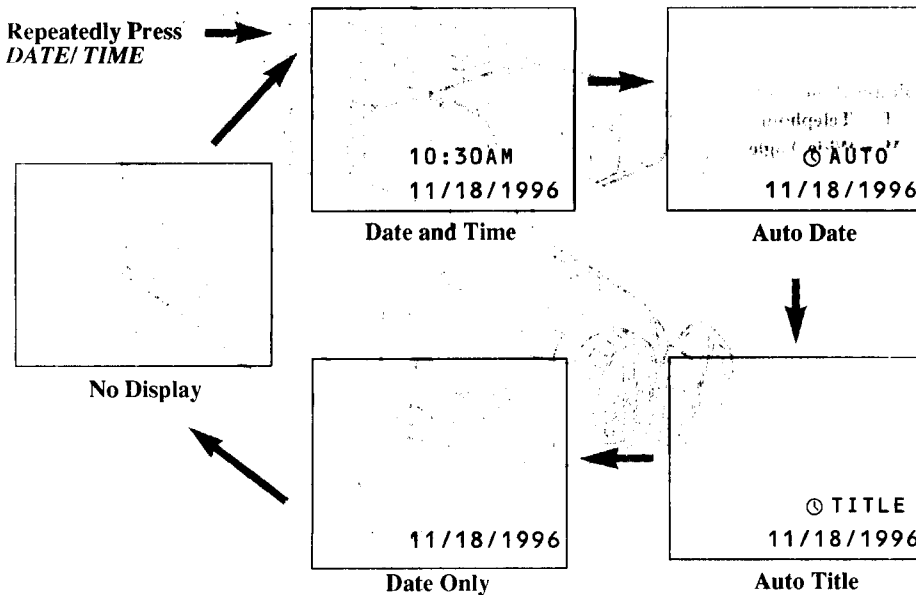

To Select Display to Record

1. Repeatedly press *DATE/TIME* to select the display you want to record.
 - Select date and time to continuously record the date and time.
 - Select \odot *AUTO* to automatically record the date for 10 seconds at the beginning of the recording.

- Select \odot *TITLE* to automatically record the title and date for 10 seconds at the beginning of the recording.
- Select date only to continuously record the date.
- Select no display if you do not want any of the displays recorded.

Charging the Camcorder's Built-in Clock Battery

The camcorder has a built-in rechargeable clock battery.

This battery must be charged approximately every two months.

1. Attach a power supply (adapter/ charger or charged battery) to the camcorder.
2. Make sure *CAMERA/OFF/VCR* is in *OFF*.
3. Leave the power supply attached at least 24 hours.

Caution: If this battery is not charged every two months, it will over-discharge and shorten its useful life.

Do not attempt to replace this battery.

Take the camcorder to an authorized Servicenter.

Zooming

Using Power Zoom Buttons

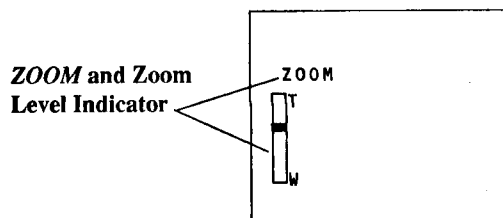
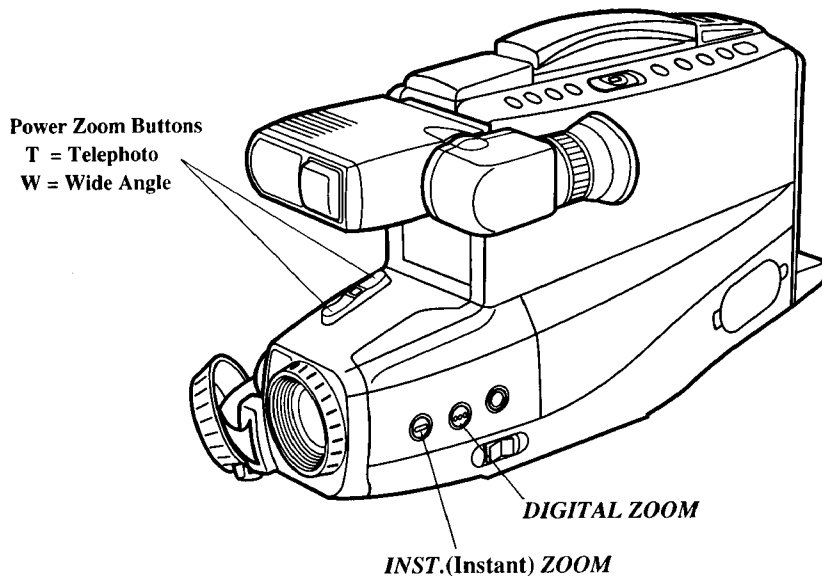

When *DISPLAY* is pressed so the display appears in the viewfinder and the power zoom button is pressed, the zoom level is displayed in 10 steps for several seconds.

- Press “T” to move the lens in the “telephoto” (close-up) direction.

ZOOM appears in the viewfinder when you zoom in more than 12 times.

- Press “W” to move the lens in the “wide-angle” direction.

Zooming (continued)

Using *INST.* (Instant) *ZOOM*

Instant Zoom
Indicator



I.ZOOM

- Press *INST.ZOOM* to magnify the subject 1.5 times regardless of the position of the power zoom buttons. When *DISPLAY* is pressed, *I.ZOOM* appears in the viewfinder during instant zoom.
- Press *INST.ZOOM* again to turn off instant zoom.

Digital Zooming



ZM:2
ZOOM

The digital zoom feature allows you to zoom in on a subject with magnification of up to 100 times.

1. Press *DISPLAY* and repeatedly press *DIGITAL ZOOM* to select the digital zoom mode.
 - The normal zoom mode is wide angle to 12 times. No display appears in the viewfinder.
 - Select *ZM:2* to activate the extended zoom mode — from wide angle to 100 times for special effects.

- Select *16X9* to make a recording that will be played back on a 16 X 9 TV. *See next page for details.*

2. Press power zoom button “*W*” or “*T*” to control the digital zoom ratio.

Notes: *ZOOM* appears in the viewfinder for zoom levels above 12X. It will not be recorded on the tape.

As the zoom level increases in the *ZM:2* mode, the picture will gradually become less sharp. Extremely high zoom levels are used mainly for special effects.

Zooming (continued)

16X9 Mode

The new 16 X 9 TV format provides a 30% wider picture than conventional TVs of the same height. The 16 X 9 recording mode lets you make recordings compatible with this new format. When the 16 X 9 mode is activated, the camcorder records black bars at the top and bottom of the picture to produce the wide-screen effect. This is known as "letter box" recording. When played back on a standard size TV, black bars appear in the picture.

Do not use this recording mode unless you have a 16 x 9 TV.

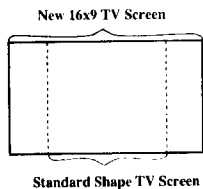

16X9 Mode



Normal Mode

To Record in the 16X9 Mode

1. Press *DISPLAY* and repeatedly press *DIGITAL ZOOM* to select 16 x 9. The following display will appear in the viewfinder.
2. To turn off the 16 x 9 mode, repeatedly press the *DIGITAL ZOOM* button to return to the normal mode. No display will appear in the viewfinder.

16 x 9
Indicator

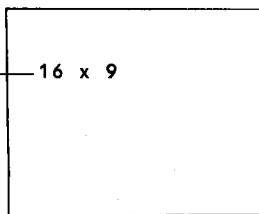

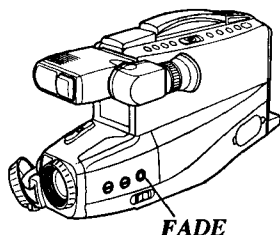

Fading In and Out of Scenes

You can add a professional touch to your recordings when you fade in and out of scenes. Both the picture and sound will gradually appear or disappear. The speed of the fade is controlled by the camcorder.



Select the Type of Fade

You can select white, wipe, or zoom fade. Press *DISPLAY* to display the fade mode icon.

- Select white fade to fade in and out from a white screen.  appears in the viewfinder.
- Select wipe fade to fade in and out from a black screen.  appears in the viewfinder.
- Select zoom fade to fade in and out while zooming.  appears in the viewfinder.

Repeatedly Press *FADE*

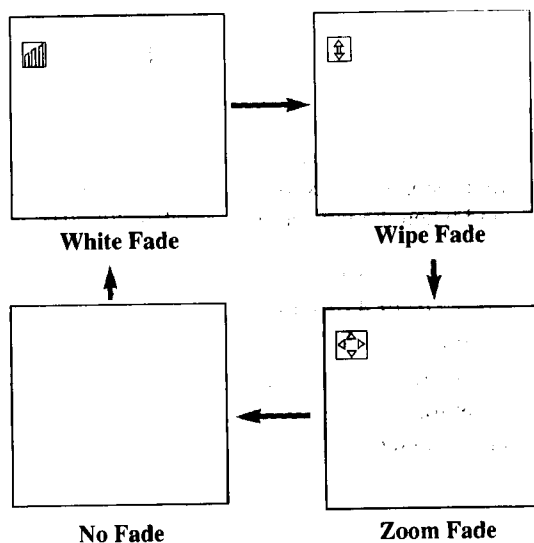

Fade In

1. Place the camcorder in record pause.
2. Repeatedly press *FADE* to select fade mode.
Note: The last fade mode used will appear the first time you press *FADE*.
3. Press *REC/PAUSE* to start recording. The picture and sound will gradually appear in place of the blank screen.

Fade Out

1. During recording, repeatedly press *FADE* to select the fade mode.
Note: The last fade mode used will appear the first time you press *FADE*.
2. Press *REC/PAUSE* to stop recording. The picture and sound will gradually disappear.

Tape Counter with Memory Stop

The tape counter acts as a handy reference to help you locate tape segments.

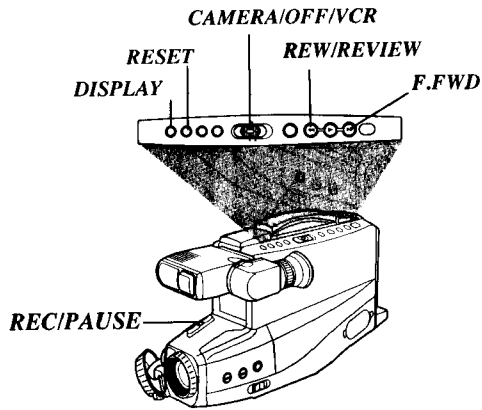

Memory Stop

The tape counter's memory stop helps you locate a certain point on the tape. When memory stop is turned on, the tape will stop automatically during fast forward or rewind when the tape counter reaches "0000M."

Using Memory Stop:

1. Press *DISPLAY* to display the tape counter with "M."
2. Locate the place on the tape you want to return to and press *RESET* to reset tape counter to "0000M."
4. Make sure *CAMERA/OFF/VCR* is in *VCR*. Then press *REW/REVIEW*. The tape will rewind until it reaches the tape counter reading of "0000M."

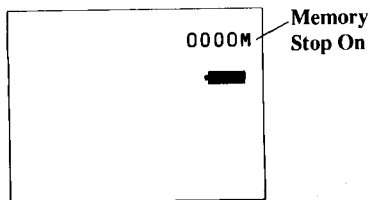

3. Continue to record or play the tape. When you want to return to the place you marked, press *REC/PAUSE* to stop recording, or press *STOP/EJECT* to stop playback.

Notes: Press *DISPLAY* to turn memory-stop feature on or off.

Whenever memory stop is turned on, the camcorder will stop rewinding or fast forwarding when the counter reaches "0000M." To continue rewinding or fast forwarding the tape, press *REW* (rewind) or *F.FWD* (fast forward) again.

The tape counter is automatically reset to "0000" whenever a cassette is inserted.

ProEdit Features

ProEdit® System



- Flying Erase Head
- Edit Search
- Audio Dub
- A/V (Audio and Video) Dub
- Titler

The camcorder incorporates a complete package of advanced editing features to make it easy and fun to edit your home videos like a professional. The major ProEdit® System features *are described here and on the following pages.*

Flying Erase Head



A separate erase head is mounted on the spinning headwheel (hence the term “flying”). The flying erase head allows you to make clean edits without “glitches” or “rainbow noise”.

Edit Search



The edit-search feature allows you to edit as you make your recording by using *F.FWD*, *REW/REVIEW*, and *PLAY* to precisely position the tape while the camcorder is in record pause.

- Press and hold *REW/REVIEW* to visually search the recorded tape in reverse.
- Press and hold *F.FWD* to visually search forward on the recorded tape.
- Press and hold *PLAY* to view the recorded tape at normal speed.

When you release the button, the camcorder will return to record pause at that point on the tape.

ProEdit Features

Audio Dubbing

PRO EDIT

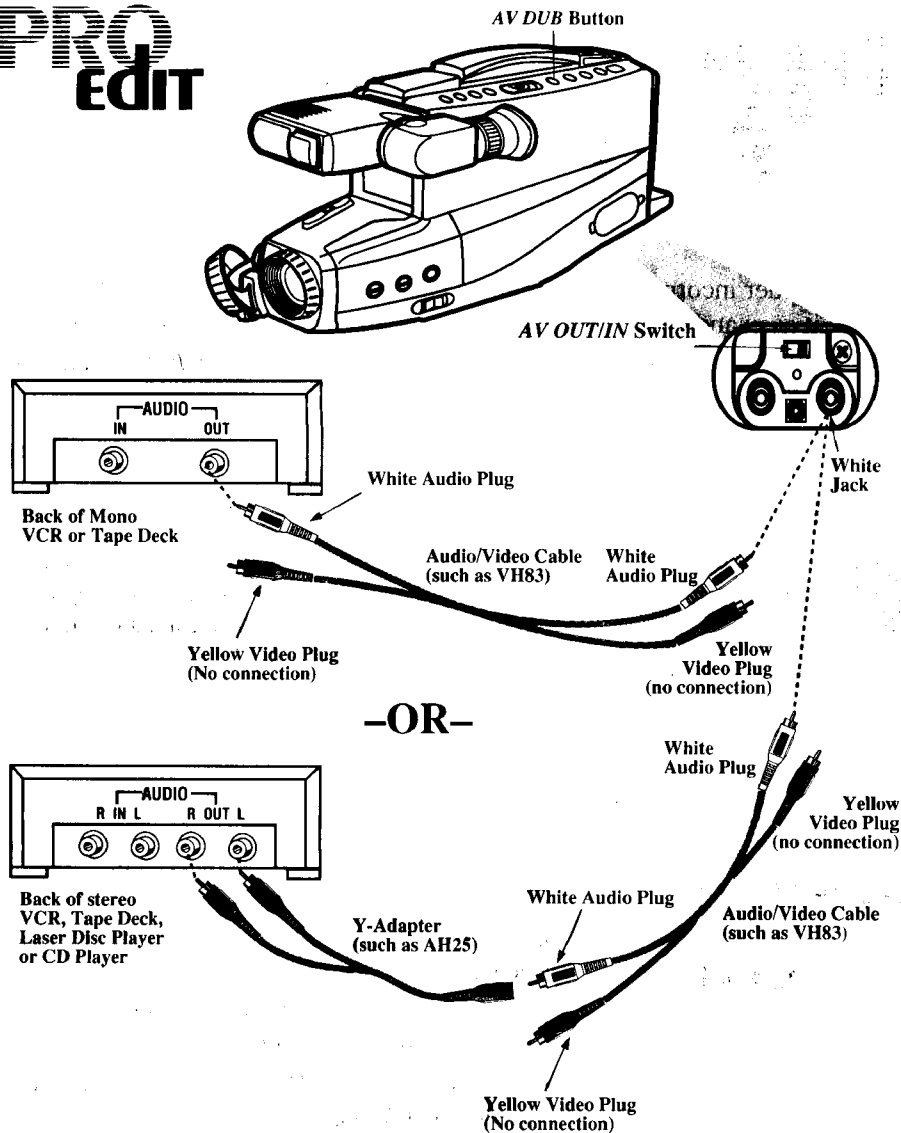

Note: You will need an optional audio/video cable, such as VH83 shown on page 56. If the audio source has separate left and right outputs, attach the audio plug to the one labeled *MONO*. If one is not labeled *MONO*, you may need a Y-adapter, as shown on page 56, to record audio from both the left and right channels.

ProEdit Features

Audio Dubbing



The audio dub feature lets you record new audio (sound) on a previously recorded tape without erasing the original video (picture). The previous audio is erased and replaced with the new audio.

The audio dub feature increases your editing flexibility. Video segments can first be assembled and then a single narration or music background can be added.

The new audio can be added two different ways.

- You can speak into the camcorder's built-in microphone.
- You can connect an external sound system to the white *AUDIO* jack on the camcorder.

To Audio Dub

1. Press and hold the small button on *CAMERA/OFF/VCR* while sliding it to *VCR*.
2. If you are recording from a source connected to the white *AUDIO* jack on the side of the camcorder, place *AV OUT/IN* switch to *IN*.
3. Insert the tape you want to audio dub and use *PLAY*, *F.FWD*, and *REW/REVIEW* to locate a point on the tape a few seconds before you want to begin dubbing.
4. Press *REC/PAUSE* exactly where you want to begin dubbing. This will place the camcorder in play pause.
5. Press and hold *AV DUB*, and then press *PLAY*. Release both buttons at the same time. *A. DUB II* will appear in the viewfinder when the camcorder is ready to begin audio dubbing.

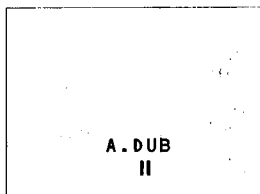

6. To begin dubbing, start the audio source and press *REC/PAUSE*. *II* will disappear from the viewfinder while you are dubbing.
7. Press *STOP/EJECT* when you are finished dubbing.

Remember: Place the *AV OUT/IN* switch to *OUT* to record on the camcorder.

Notes: If you want to stop dubbing at a certain point on the tape, turn on memory stop, and set tape counter to "0000M" at the point where you want the dubbing to stop. The camcorder will stop dubbing automatically when it reaches "0000M."

ProEdit Features

Audio and Video Dubbing

PRO EDIT

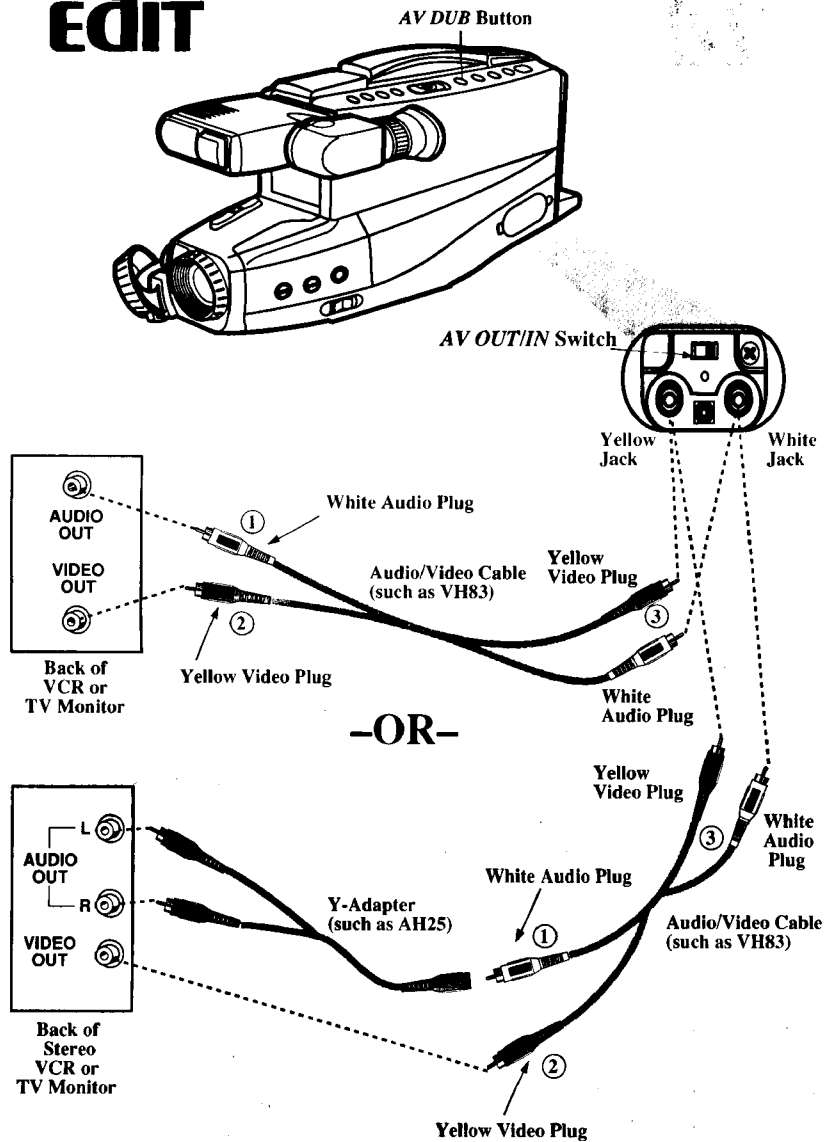

ProEdit Features

Audio and Video Dubbing

PRO EDIT

The audio and video dubbing feature lets you record new audio (sound) and video (picture) on a previously recorded tape in the camcorder.

The source for the dubbing is the camcorder's microphone and camera or a source connected to the *AUDIO/VIDEO* jacks on the side of the camcorder.

- To record from the camcorder's microphone and camera, no special connections are required.
- To record from an external video source (VCR, laserdisc player, etc.), you will need an optional audio/video cable, such as AH83 shown on page 56.

To Audio and Video Dub

1. Press and hold the small button on *CAMERA/OFF/VCR* while sliding it in *VCR*.
2. If you are recording from a source connected to the *AUDIO/VIDEO* jacks on the side of the camcorder, place the *AV OUT/IN* switch to *IN*.
3. Insert the tape you want to dub and use *PLAY*, *F.FWD*, and *REW/REVIEW* to locate a point on the tape a few seconds before you want to begin dubbing.
4. Press *REC/PAUSE* exactly where you want to begin dubbing. This will place the camcorder in play pause.
5. Press and hold *AV DUB*, and then press *PLAY*. Release both buttons at the same time. *A. DUB II* will appear in the viewfinder when the camcorder is ready to begin audio dubbing.
6. Press and hold *AV DUB*, and then press *PLAY* again. Release both buttons at the same time. *A/V DUB II* will appear in the viewfinder when the

camcorder is ready to begin audio and video dubbing.

Note: If you are dubbing from a source connected to the *AV OUT/IN* jacks, be sure to start it playing.

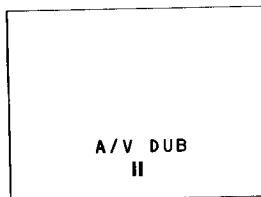

7. To begin dubbing, press *REC/PAUSE*. *II* will disappear from the viewfinder while you are dubbing.
 8. Press *STOP/EJECT* when you are finished dubbing.
- Remember:** Place the *AV OUT/IN* switch to *OUT* to record on the camcorder.

Notes: If you want to stop dubbing at a certain point on the tape, turn on memory stop and set the tape counter to "0000M" at the point where you want the dubbing to stop. The camcorder will stop dubbing automatically when it reaches "0000M."

ProEdit Features

Titler

PRO EDIT

The camcorder's built-in titler can store a title in memory. The created title can be displayed and recorded at any time.

The built-in character register contains over 45 different characters for creating your titles. The title can contain up to 32 characters on two lines.

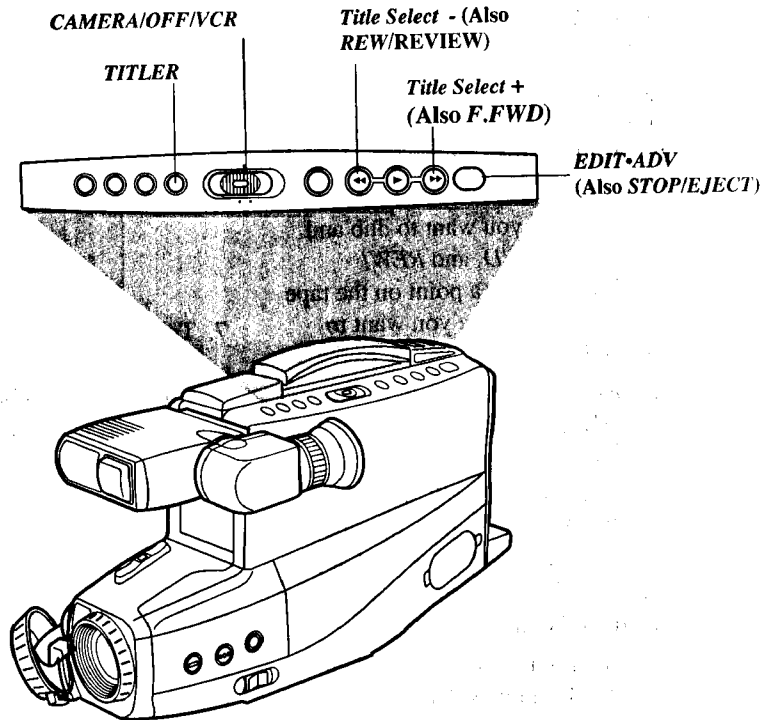

ProEdit Features

To Create a Title

1. Attach a power source to the camcorder, press and hold the small button on *CAMERA/OFF/VCR* while sliding it to *CAMERA*.
2. Press *TITLER* to display titler graphics in the viewfinder. A flashing cursor will appear.
3. Press *EDIT•ADV* to move the flashing cursor to the place you want to begin your title.
4. Select the first character for your title by pressing the *Title Select +* button or the *-* button until the character you want appears in the viewfinder.

See the "Chart of Characters in Titler's Register" below for the characters available.

5. After you have selected the first character, press *EDIT•ADV* to move the flashing cursor where you want your next character to appear.
6. Repeat steps 4 and 5 until you have completed the title.
7. When you are finished, press *TITLER* to store the title and remove the title display from the viewfinder.

Important Note: Remember to remove the titler graphics from the viewfinder for normal recording.

To Correct an Error

1. Press *TITLER* to display the titler graphics in the viewfinder.
2. Press *EDIT•ADV* until the flashing cursor is placed over the character you wish to correct.

3. Press the *Title Select +* button or the *-* button until the correct character appears.

Note: If you want to delete a character, press *+* or *-* until the blank space appears.

Chart of Characters in Titler's Register																		
A	B	C	D	E	F	G	H	I	J	K	L	M	N	O	P	Q	R	S
T	U	V	W	X	Y	Z	0	1	2	3	4	5	6	7	8	9	?	'
.	/	,	-	;	:	<	>	!	(BLANK)									

ProEdit Features

Recording a Title on a Tape in the Camcorder

To record a title on a tape in the camcorder, follow the steps below.

1. Attach a power source to the camcorder, slide *CAMERA/OFF/VCR* to *CAMERA*.
2. Locate the place on the tape where you want to record the title.
Notes: If you record a title on a pre-recorded tape, the audio and video will be erased where the title is inserted. There will also be a three-to-four second pause of blank tape before the existing audio and video return.
Audio and video dubbing titles onto existing tapes will eliminate the pauses of blank tape. *Details are on pages 36-37.*
3. Press *TITLER* to display the titler graphics in the viewfinder.
4. Press *REC/PAUSE* to start recording the title.
5. After you have recorded the title for the desired length of time, press *TITLER* to remove titler graphics from the viewfinder. The camcorder will now record as normal. If you do not want to continue recording, press *REC/PAUSE*.

Important Note: Remember to remove the titler graphics from the viewfinder for normal recording.

Note: You can also use the automatic title recording feature to automatically record the title and date for 10 seconds when you begin recording. Press *DATE/TIME* to display  *TITLE* before starting to record.

Recording a Title While Copying a Tape from Camcorder to Another VCR

This method of adding titles lets you keep the *original tape as it is*, and add titles to the copy you are making on another VCR. Connect your camcorder to a VCR *as shown on pages 46-47*.

1. Attach a power source to the camcorder.
2. Place the tape you want to copy in the camcorder and place *CAMERA/OFF/VCR* in *VCR*.
3. Place a blank tape in the VCR, and place the VCR in record pause.
4. Start copying the tape from the camcorder to the VCR. *Details for copying a tape are on pages 46-47.*
5. When you see the place on the tape you want to insert the title, press *TITLER*.
6. After you have recorded the title for the desired time, press *TITLER* to stop recording the title.
7. Stop the camcorder and VCR when you are finished copying the tape.

Important Note: Remember to remove the titler graphics from the viewfinder for normal playback.

Recording Tips

Make a recording of your home and contents to store in a safe place in case of fire or theft.

Practice recording under a variety of lighting conditions. This will help you respond quickly whenever you see a scene you want to record.

Fading in and out of scenes may make your videos appear more professional.

Do not move the camcorder rapidly from side-to-side while recording. A steady, gradual “pan” avoids blurring and “jitter”.

Use the viewfinder to make sure the camcorder is level while recording or your scenes will appear “tilted”.

Make sure indoor scenes are well-lit to improve picture quality and color reproduction.

Do not bump or tap the camcorder’s microphone while recording because this sound will be recorded.

Be aware of video and audio backgrounds. Background details barely noticed while you are taping may show up as visual “clutter” on your recording. Background noises (especially TV sets, radios, household appliances, traffic sounds, etc.) can detract from the sound you want to record.

Avoid long “still” shots of landmarks and scenic attractions. Recordings are more interesting if they include people and details. “Local color” will give travel videos lasting appeal. Consider recording a familiar or landmark scene from an unfamiliar vantage point for added interest. Remember to check the lighting before starting to record.

Try to avoid taping backlit subjects indoors. Bright light behind your subject may cause the subject to appear too dark.

Include close-up shots of individuals when taping family outings or group functions.

For a different perspective, try kneeling down (or laying) on the floor when recording children or pets.

Recording on the Camcorder from a VCR or TV Monitor

To record on a tape in your camcorder from a VCR or TV monitor with *AUDIO OUT* and *VIDEO OUT* jacks, you will need an optional audio/video cable, such as VH83 shown on page 56.

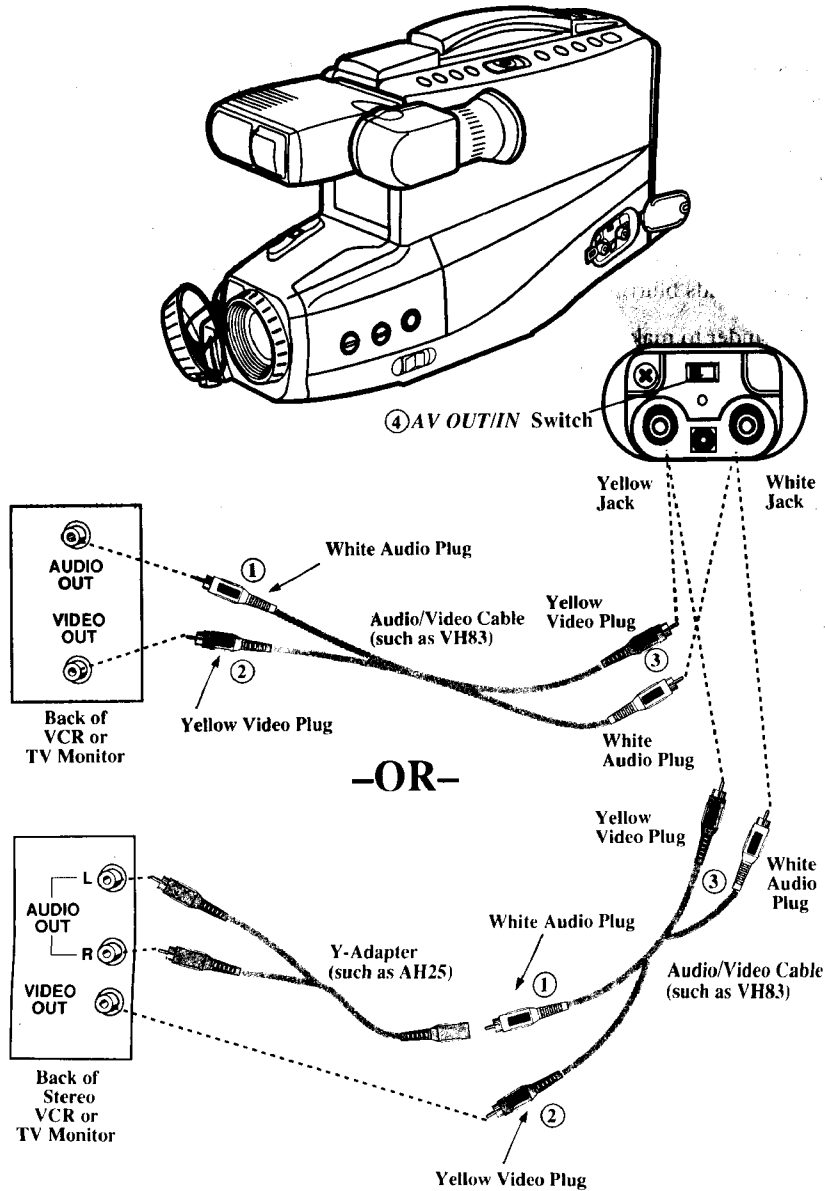

Recording on the Camcorder from a VCR or TV

Installation

- ① Attach the white plug on one end of the audio/video cable to the *AUDIO OUT* jack on the VCR (or TV monitor).
Note: If your VCR or TV monitor has stereo left and right *AUDIO OUT* jacks, attach the plug to the one labeled *MONO*. If one of the audio jacks is not labeled *MONO*, you may need a Y-adaptor, such as AH25 shown on page 56, to hear both channels.
- ② Attach the yellow plug on the same end to the *VIDEO OUT* jack on the VCR (or TV monitor).
- ③ Attach the yellow plug on the other end of the audio/video cable to the yellow *VIDEO* jack and the white plug to the white *AUDIO* jack on the side of the camcorder.
- ④ Place the *AV OUT/IN* switch to *IN*.

Recording Operation and How to Copy Tapes on the Camcorder

1. A. Camcorder connected directly to TV monitor: Turn on the TV and tune it to the channel you want to record.
- B. Camcorder connected to a VCR that is already connected to a TV: Turn on the VCR and select the channel you want to record (or place the cassette you want to copy in the VCR). If you are copying a tape, press *PLAY* on the VCR when you are ready to start copying.
Note: If you want to see what is being recorded, turn on the TV and tune it to the channel that you normally use to see the signal from the VCR.
2. Press and hold the small button on the camcorder's *CAMERA/OFF/VCR* switch while sliding it to *CAMERA*.
3. Insert a cassette in the camcorder with the safety tab intact.
4. Press *REC/PAUSE* to start the camcorder recording.
Note: If you are copying a tape, start the VCR playing the tape.
5. Press *REC/PAUSE* on the camcorder when you are finished.
Remember: Place the *AV OUT/IN* switch to *OUT* to record on the camcorder.

Caution: The unauthorized recording of television programs and other materials may infringe the rights of others.

Viewfinder Playback and Playback Features

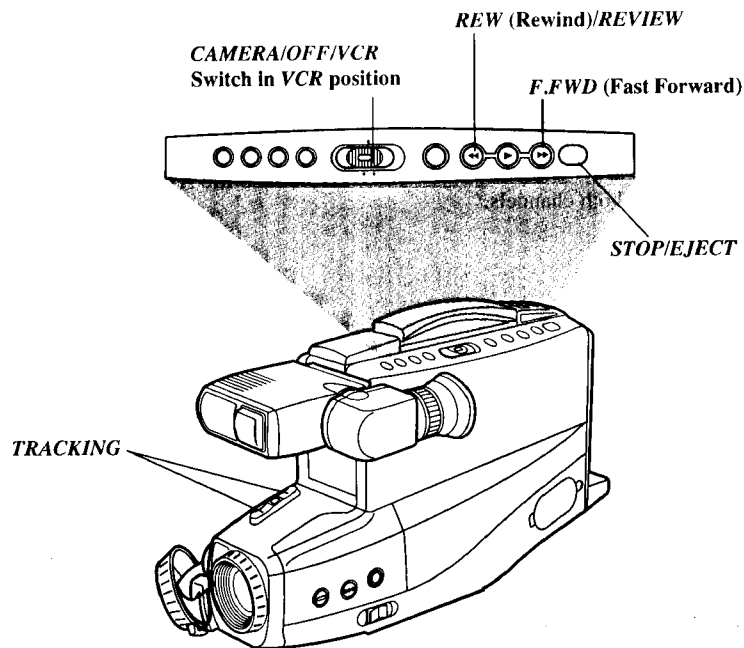

Viewfinder Playback

1. Attach a power supply to the camcorder.
2. Press and hold the small button on *CAMERA/OFF/VCR* while sliding it to *VCR*.
3. Press *STOP/EJECT* and insert the cassette you want to play back.
4. Press *PLAY* to begin playback. Adjust *TRACKING* if necessary.
5. Press *STOP/EJECT* when you are finished.

Note: The camcorder can only play back tapes recorded at SP speed.

Viewfinder Playback and Playback Features

Playback Features

Stop-Action Pause

During playback, you can view one frame of the tape.

- Press *REC/PAUSE* to stop the action.
- Press *REC/PAUSE* again to return to normal playback.

Caution: Pause is designed for momentary interruptions and should not be used for an extended period of time. If the camcorder remains in pause for more than five minutes, it will automatically remove the tape from the spinning heads to prevent excessive tape wear.

Picture Search

During playback you can visually search the tape at a higher speed in forward or reverse.

- Press and hold *F.FWD* to search the tape forward.
- Press and hold *REW/REVIEW* to search the tape in reverse.
- Release the button to return to normal playback.

Tracking

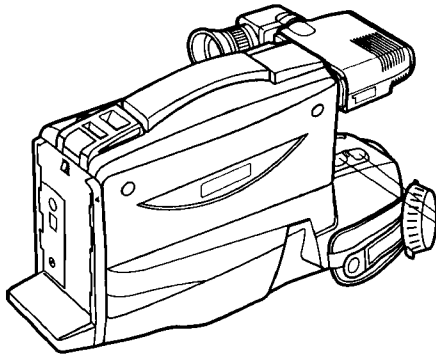

TRACKING
(Also Power Zoom)

When you play a tape not recorded on your camcorder, streaks may appear. To remove the streaks, press either *TRACKING* button to move the streaks up or down and out of the picture.

Press either *TRACKING* button during stop-action (play-pause) to reduce picture "jitter" (picture bouncing up or down).

Remove the cassette to reset the camcorder's tracking to its preset center.

The *TRACKING* buttons only affect tape playback. They have no effect during recording.

Playback on a TV or VCR with *AUDIO* and *VIDEO IN* Jacks

To connect your camcorder to a TV monitor (or VCR) with *AUDIO IN* and *VIDEO IN* jacks, you will need an optional audio/video cable, such as VH83 shown on page 56. If your TV is already connected to a VCR, you can attach the camcorder to the VCR and watch what the camcorder is recording or playing on the TV.

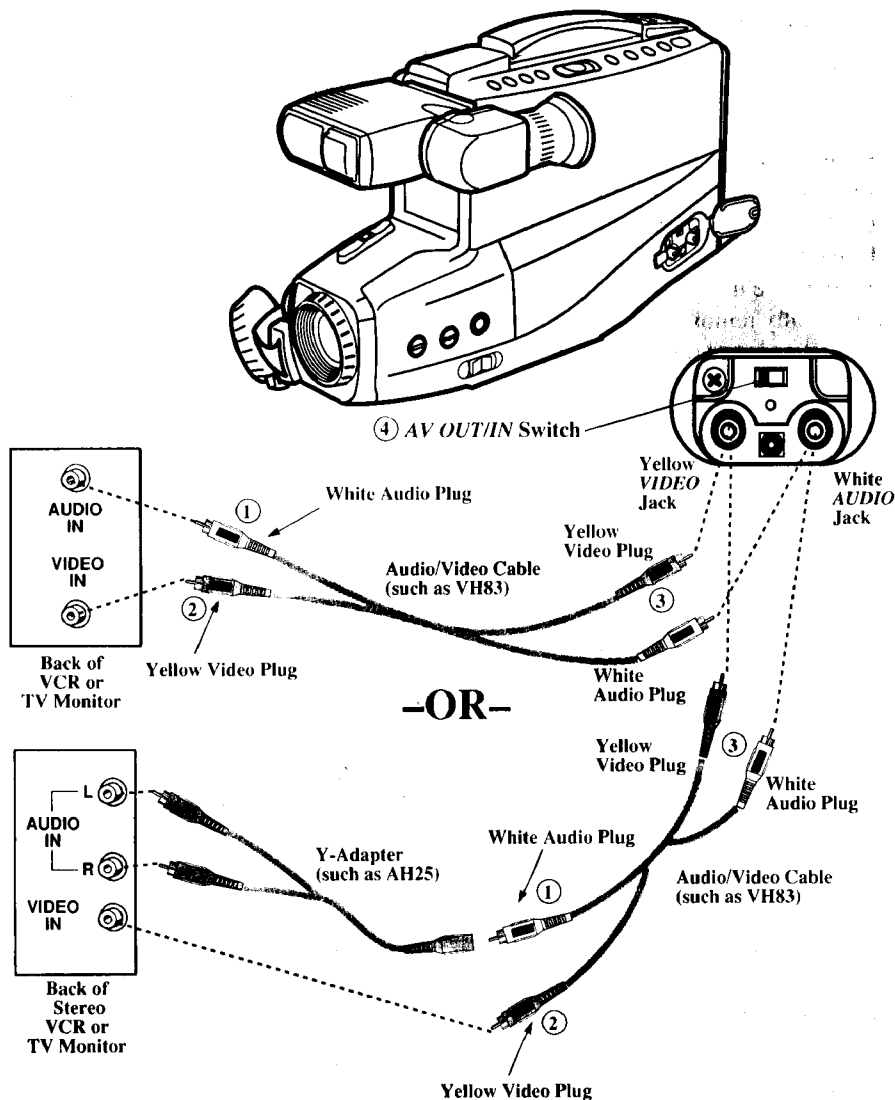

Caution: The unauthorized recording of television programs and other materials may infringe the rights of others.

Playback on a TV or VCR with *AUDIO* and *VIDEO IN* Jacks

- ① Attach the white plug on one end of the audio/video cable to the *AUDIO IN* jack on the TV or VCR.
Note: If your TV (or VCR) has stereo left and right *AUDIO IN* jacks, attach the plug to the one labeled *MONO*. If one of the jacks is not labeled *MONO*, you may need a Y-adaptor, such as AH25 shown on page 56, to hear both channels.
- ② Attach the yellow plug on the same end of the audio/video cable to the *VIDEO IN* jack on the TV or VCR.
- ③ Attach the yellow plug on the other end of the audio/video cable to the yellow *VIDEO* jack and the white plug to the white *AUDIO* jack on the side of the camcorder.
- ④ Place the *AV OUT/IN* switch to *OUT*.

Playback Operation and How to Copy Tapes on a VCR

1. A. Camcorder connected directly to TV monitor: Turn on the TV and tune it to its video input channel.
B. Camcorder connected to VCR that is already connected to TV: Turn on VCR and place it in the “line” or “camera” mode. (If your VCR does not have a “line” or “camera” mode, consult the VCR owner’s manual.) Operate the TV as you normally do to see the signal coming from the VCR.
2. Press and hold the small button on the camcorder’s *CAMERA/OFF/VCR* switch while sliding it to *VCR*. Insert the cassette you want to playback (or copy).
Note: The camcorder can only play back tapes recorded at the SP speed.
3. Press *PLAY* on the camcorder. To copy what the camcorder is playing, place a blank cassette in the VCR and start the VCR recording. Adjust the tracking on the camcorder if necessary. *Details are on page 45.*
 - During playback, use the playback features *described on page 45.*
4. Press *STOP/EJECT* when you are finished.

Watching What the Camcorder is Seeing or Recording on the TV

1. A. Camcorder connected directly to TV: Turn on the TV, and tune it to its video input channel.
B. Camcorder connected to VCR that is already connected to TV: Turn on VCR and place it in the “line” or “camera” mode. (If your VCR does not have a “line” or “camera” mode, consult the VCR owner’s manual.) Operate the TV as you normally do to see the signal coming from the VCR.
2. Press and hold the small button on the camcorder’s *CAMERA/OFF/VCR* switch while sliding it to *CAMERA*. Insert the cassette you want to record on.
Note: When the camcorder is used as a camera, turn the TV’s volume down to prevent a high-pitched squeal caused by feedback.
3. Press the camcorder’s *REC/PAUSE* button to begin recording. You can watch what the camcorder is seeing or recording on the TV screen.

Playback on a TV Without Audio and Video Inputs

To connect your camcorder to a TV without audio and video input jacks. You will need an optional RF output adapter (such as CRF95) and an optional coaxial RF cable (such as VH82 or VH85) shown on page 56.

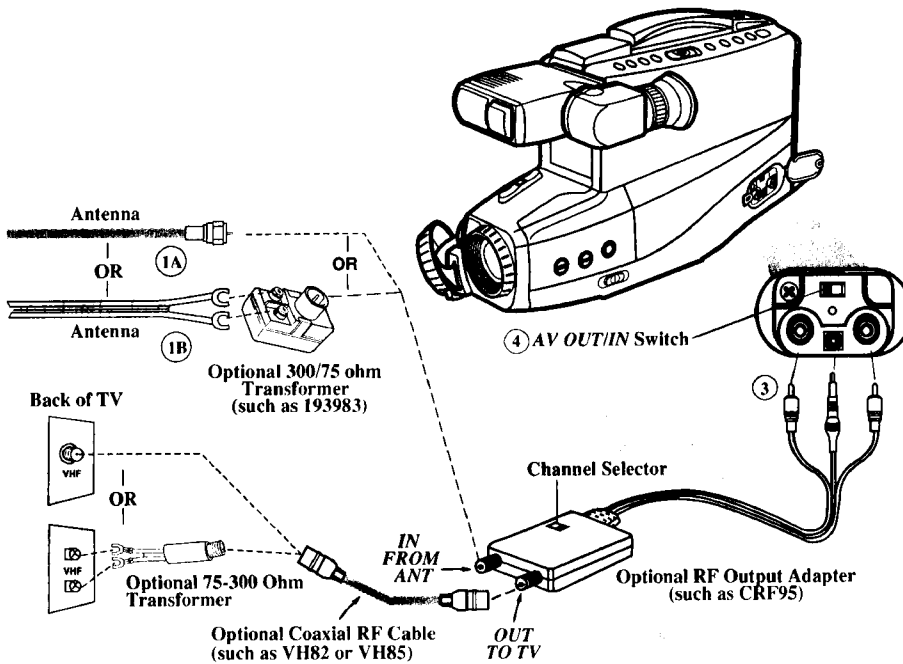

- 1 Disconnect the VHF antenna from your TV. If you are going to leave the RF adapter connected to the TV, connect the antenna to the RF output adapter.
 - A. If antenna is round 75-ohm cable, connect it to *IN FROM ANT* connector on RF output adapter.
 - B. If antenna is flat twin-lead, connect flat-lead connectors to screw terminals on optional 300-75 ohm transformer. Then connect transformer to *IN FROM ANT* connector on RF output adapter.

- 2 Attach one end of coaxial RF cable to *OUT TO TV* connector on RF adapter, and attach other end of the cable to VHF input on TV as shown.

Note: If TV has screw terminals, you may need an optional 75-to-300 ohm transformer, such as AH011.
- 3 Attach RF output adapter's yellow plug to the *VIDEO* jack, small plug to the *RF DC OUT* jack, and white plug to the *AUDIO* jack on the side of the camcorder.
- 4 Place the *AV OUT/IN* switch to *OUT*.

Playback on a TV Without Audio and Video Inputs

Playback Operation

1. Set the channel selector switch on the RF output adapter to *CH3* or *CH4*.
2. Turn on the TV and tune it to the same channel (3 or 4) you selected with the channel selector switch on the RF output adapter.
3. Press and hold the small button on the camcorder's *CAMERA/OFF/VCR* switch while sliding it to *VCR*.
4. Insert the cassette you want to play back into the camcorder.
Note: The camcorder can only play back tapes recorded at the SP speed.
5. Press *PLAY* on the camcorder. Adjust tracking on the camcorder, if necessary. *Details are on page 45.*
 - During playback, use the playback features *described on page 45.*
6. Press *STOP/EJECT* on the camcorder when you are finished playing back the tape.

Watch What the Camcorder is Seeing or Recording on the TV

1. Turn on the TV and tune it to channel 3 or 4 (the same channel you selected with the *CH3/CH4* switch on the RF output adapter).
2. Press and hold the small button on the camcorder's *CAMERA/OFF/VCR* switch while sliding it to *CAMERA*. Insert the cassette you want to record on.
3. Press the camcorder's *REC/PAUSE* button to begin recording. You can watch what the camcorder is seeing or recording on the TV screen.
Note: When the camcorder is used as a camera, turn the TV's volume down to prevent a high-pitched squeal caused by feedback.

Normal TV Viewing

For normal TV viewing, you can leave the RF output adapter hooked up to the TV. Just disconnect the adapter's plug

from the camcorder or turn the camcorder's power off.

Note to Cable-TV Installer: This reminder is provided to call your attention to Article 820-40 of the National Electrical Code (Section 54 of Canadian Electrical Code, Part I), that provides guidelines for proper grounding and, in particular, specifies that the cable ground shall be connected to the grounding system of the building as close to the point of cable entry as practical.

Color Enhancement Light

The color enhancement light helps create brighter, sharper pictures.

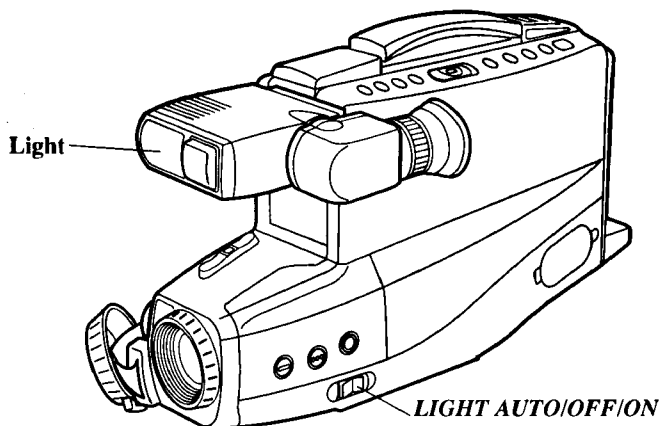

To Use the Color Enhancement Light

1. Attach the rechargeable battery or AC adapter/charger to power the camcorder.
2. Press and hold the small button on *CAMERA/OFF/VCR* and place it in *CAMERA*.
3. Select a position for the *LIGHT AUTO/OFF/ON* switch.
 - Place in *AUTO* to have the light automatically turn on when the camcorder is aimed at a dark object and turn off when aimed at a bright object.
 - Place in *ON* to have the light turn on whenever *CAMERA/OFF/VCR* is in *CAMERA*.
 - Place in *OFF* to turn off the light.

Note: A cassette must be inserted for *AUTO* to operate.

If the camcorder is left in record pause for more than five minutes, the power

and light automatically turn off. Press *REC/PAUSE* to turn camcorder back on.

Notes: Turn on the light only when you need it. The power consumption of the light is approximately two-thirds that of the camcorder. When the light is on, the operation time of the rechargeable battery is reduced.

Avoid bumping or shaking the light when in use. The light's bulb is sensitive when hot and may burn out.

Do not allow water to drop on the light when in operation.

Dangers: During operation and after using the light, the front surface and bulb of the light will be very hot. To avoid burns, do not touch them.

To prevent overheating, do not block or cover the ventilation holes on the color enhancement light.

Never use the color enhancement light in the vicinity of explosives or highly flammable materials.

Color Enhancement Light

Removing and Replacing the Front Case of the Light

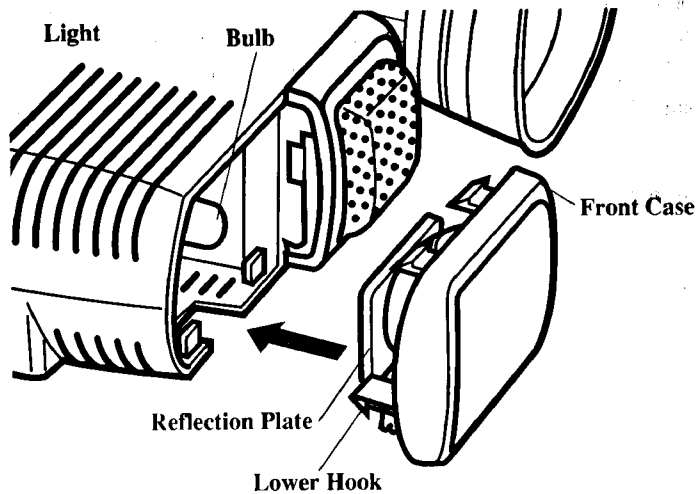

To Remove and Replace Light Case

1. To remove front case, press and hold the lower hook while removing it.
2. To replace the front case, pass the bulb through the hole of the reflection plate, and attach the lower hook to the light.
3. Press front of case to light.

Notes: Do not touch the bulb with your fingers. It may shorten its service life.

Make sure the front case of the light is properly attached after removing it or replacing a bulb.

When replacing the bulb, only use #221111 to reduce the risk of fire and other hazards.

See the installation instructions packed with the replacement bulb when replacing the bulb.

Caution: Use only bulb #221111 when replacing the bulb to reduce the risk of fire or other hazards.

Attaching the Shoulder Strap

The shoulder strap is designed to let you carry the camcorder from your shoulder and — when you are ready to shoot — bring the camcorder to shooting position in one quick movement.

Cautions: When carrying the camcorder with the shoulder strap, place the viewfinder in its original position. This helps prevent possible damage to the viewfinder from bumping against your body as you move.

Make sure the shoulder strap is firmly attached before using it to carry your camcorder.

To Attach the Shoulder Strap

1. Unfasten one end of the shoulder strap from the buckle. Make sure you leave the buckle on the strap.

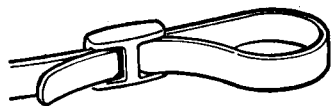

2. Thread one end of the shoulder strap through one of the shoulder strap rings as shown below in diagrams A and B.

Diagram A

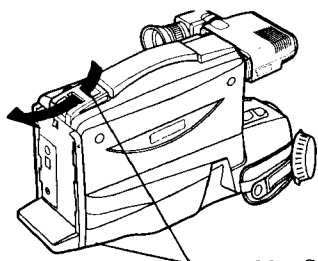

Shoulder Strap Rings

Diagram B

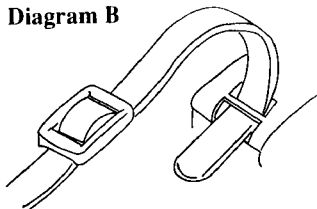

3. Thread the strap back into the buckle as shown below. Pull on the strap and make sure it is fastened correctly and tightly before using it to support your camcorder.

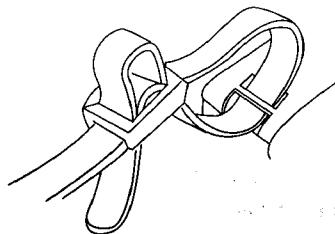

4. Repeat steps 1–3 to attach the other end of the shoulder strap.

Packing Carrying Case

The carrying case that came with your camcorder is specially designed to provide protection for your camcorder and its accessories. See below for details on packing your case.

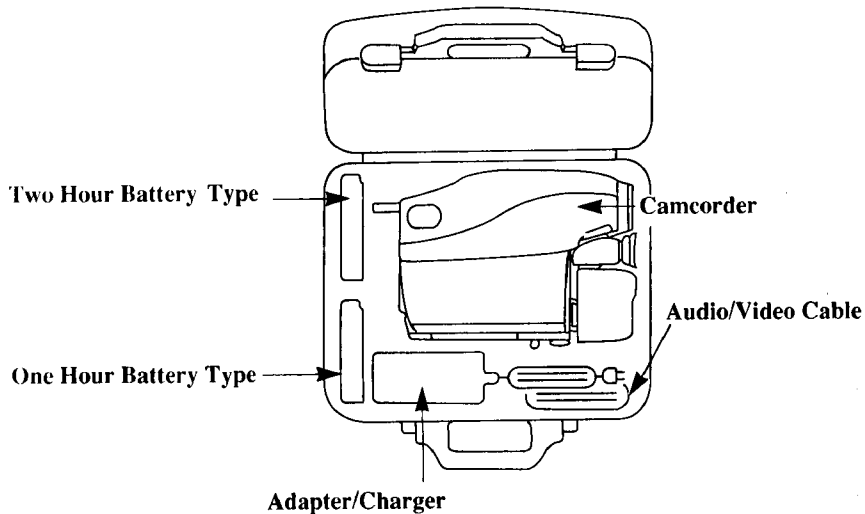

Information to User

This equipment has been tested and found to comply with the limits for a Class B digital device and RF lighting device, pursuant to Part 15 and part 18 of the FCC Rules. These limits are designed to provide reasonable protection against harmful interference in a residential installation. This equipment generates, uses, and can radiate radio frequency energy and, if not installed and used in accordance with the instructions, may cause harmful interference to radio communications. However, there is no guarantee that interference will not occur in a particular installation. If this equipment does cause harmful interference to radio or television reception, which can be determined by turning the equipment off and on, the user is encouraged to try to correct the interference by one or more of the following measures:

- Reorient or relocate the receiving antenna.
- Increase the separation between the equipment and receiver.

- Connect the equipment into an outlet on a circuit different from that to which the receiver is connected.
- Consult the dealer or an experienced radio/TV technician for help.

Alterations or modifications carried out without appropriate authorization may invalidate the user's FCC right to operate the equipment.

This Class B digital apparatus meets all requirements of the Canadian Interference-Causing Equipment Regulations.

Cet appareil numérique de la Classe B respecte toutes les exigences du Règlement sur le matériel brouilleur du Canada.

Specifications

General

Power requirement: 9.6VDC

Power consumption: 8 watts (normal)

Weight: 4.4 lbs. (2 kg)

Dimensions:

4-1/4"(W) x 8-3/8"(H) x 13-1/8"(D)
(108 x 213 x 334mm)

Video Recorder Section

Format: VHS

Record/Playback System:

Two video record/playback heads

One flying erase head

Headwheel Cylinder Diameter: 62 mm

Video Signal: EIA Standard NTSC

Color

Camera Section

Scanning: 525 Lines/60 Fields/30

Frames

Image Sensor: 1/4" high/resolution,
solid state CCD imager

Tripod Mount: One 1/4" x 20 threaded
hole

Lens: f1.6 — 12:1 (4-48mm)

Diameter: 46 mm

Adapter/Charger

Power Requirement: 120 V 50/60 Hz

Power Consumption: 30 Watts (max)

Weight: (390 grams)

Dimensions:

(78 x 52 x 155 mm)

Optional Accessories

We invite you to take a look at some great ideas for sparking creativity and adding to the fun of using your camcorder. These pages have a selection of accessories to help make your memorable moments look and sound even better.

To order accessories, contact your local dealer.

Accessories are available by calling toll-free or by using the order form. *See pages 59-61.*

AC202 Soft Camcorder Case

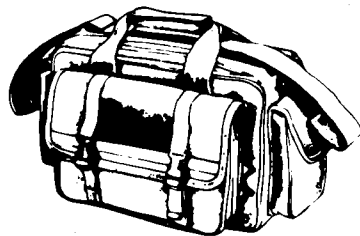

This case provides exceptional protection and utility for full size camcorders and most accessories. It is constructed of rugged nylon fabric for years of reliable service and good looks.

Three outside pockets provide ample accessory storage with mesh-covered lens filter compartment and built-in holders for memo pads, pens, and other accessories. The hand grip and adjustable shoulder strap allow for convenient, comfortable transportation of the camcorder.

Optional Accessories

DCC096 DC (Battery) Car Cord

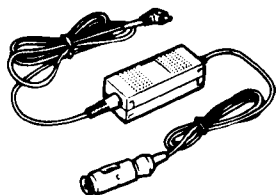

This DC car cord enables you to operate your camcorder from your car, truck, or RV by plugging the car cord directly into the vehicle's cigarette lighter.

Caution: Do not use any other car cord with this camcorder.

CPS014 AC Adapter/Charger

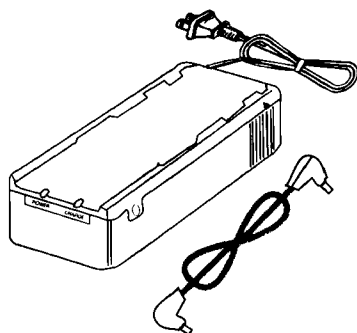

This adapter/charger operates on 100-240 volts, 50/60 Hz, so it can be used almost anywhere in the world to power your camcorder and recharge the EP096FS battery supplied with your camcorder.

It also charges the EP096FL (2 hour) battery. A simple plug adapter may be required in some countries.

EP096FS and EP096FL Rechargeable Batteries

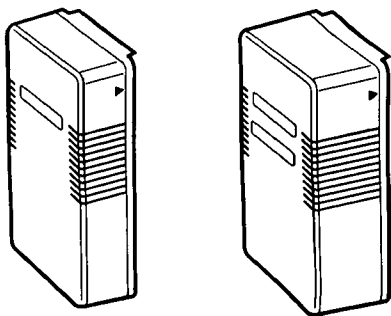

These rechargeable lead-acid batteries are specifically designed for long life. The EP096FS can power your camcorder up to one hour and the EP096FL up to two hours (depending on how much you use the light, zoom, and pause).

Both batteries can be recharged with the AC adapter/charger that came packed with your camcorder. First charging takes approximately two hours for the EP096FS and three hours for the EP096FL.

Optional Accessories

VH83 Audio/Video Cable

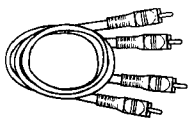

This six foot audio/video dubbing cable is used to connect your camcorder to a VCR or TV monitor to copy tapes.

CRF95 RF Output Adapter

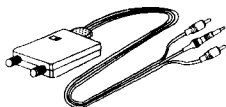

This adapter is used with coaxial RF cable (VH82 or VH85) to connect your camcorder to a standard TV (one without audio/video input jacks) for playback. If your antenna cable is the flat twin-lead type attached by two screws, you will also need a 300-75 ohm transformer such as 193983. If your TV has 300 ohm antenna screw terminals, you will need an optional 75/300 ohm transformer such as AH011.

Coaxial RF Cables



VH82 (6-ft)

VH85 (12-ft)

These RF cables are used with the RF output adapter to connect your camcorder to a standard TV (one without audio/video input jacks) for playback.

If your antenna cable is the flat twin-lead type attached by two screws, you will also need a 300-75 ohm transformer such as 193983.

If your TV has 300 ohm antenna screw terminals, you will need an optional 75-300 ohm transformer such as AH011.

193983 Cable Transformer



This 300-to-75 ohm transformer is used to connect a standard 300-ohm antenna twin-lead to a standard round 75-ohm connector.

AH011 Cable Transformer



This 75-to-300 ohm transformer is used to connect a standard 75-ohm antenna cable, such as AH065G or AH066G, to the 300-ohm screw terminals on a TV.

AH25 Y-Adapter



This Y-adapter allows you to connect your camcorder's mono audio cable to a stereo TV or VCR.

Accessory Order Form

Order Form for Camcorder Models CC437

Description	Part No.	Price	Qty.	Total
Soft Camcorder Case	AC202	\$ 49.95		
Deluxe Tripod	AC093	\$ 59.95		
Audio/Video Cable	VH83	\$ 4.39		
Cable Transformer	AH011	\$ 1.59		
RF Coaxial Cable (6-ft.)	VH82	\$ 3.29		
RF Coaxial Cable (12-ft.)	VH85	\$ 5.75		
Y-Adapter	AH25	\$ 1.95		
Rechargeable Battery	EP096FS	\$ 69.95		
Rechargeable Battery	EP096FL	\$ 79.95		
AC Adapter/Charger	CPS014	\$219.95		
RF Output Adapter	CRF95	\$ 69.95		
Car Cord	DCC096	\$ 49.95		
300-75 Cable Transformer	193983	\$ 10.00		
DC Cable	209342	\$ 13.65		
Shoulder Strap	227327	\$ 10.35		
Replacement Bulb (4 watt) for Built-in Light	221111	\$ 12.95		
AC Adapter/Charger (Supplied)	232595	\$169.95		

Total Merchandise..... \$ _____

Sales Tax \$ _____

We are required by law to collect the appropriate sales tax for each individual state, county, and locality to which the merchandise is being sent.

Shipping and Handling..... \$ 5.00

Total Amount Enclosed \$ _____

Use VISA, MasterCard, or Discover Card.

Money order or check must be in U.S. currency only.

No COD or cash.

Prices are subject to change without notice.

- Allow 4 weeks for delivery.
- All accessories are subject to availability.
- Where applicable, we will ship a superseding model.

Detach Here



Please complete other side also

Accessory Order Form

Charge your order on your VISA, MasterCard, or Discover Card by filling in below

USE YOUR CREDIT CARD

IMPORTANT: Copy complete account number from your VISA card



My card expires:

IMPORTANT: Copy complete account number from your MasterCard



Copy Number above your name on MasterCard My card expires:

IMPORTANT: Copy complete account number from your Discover Card



My card expires:

AUTHORIZED SIGNATURE

Prices are subject to change without notice.

Detach Here 

Print or type your name and address clearly. This will be your mailing label.

A complete and correct order will save you days of waiting.

Name: _____

Street: _____

_____ Apt: _____

City: _____

State: _____ Zip: _____

Please make sure that both sides of this form have been filled out completely.

Accessory Order Form

To order accessories, contact your local Dealer.

If a dealer is not nearby, you can also follow the directions below to order by telephone or direct-by-mail.

United States and Canada Orders

To place your order by phone, have your Visa, MasterCard, or Discover Card ready and call the toll-free number listed below between 8AM and 8PM (EST) Mon. - Fri., or 9AM - 5PM (EST) Sat. **Use this number only to place an order for accessory items listed on this order form.**

1 - 800 - 338 - 0376

To place your order by mail, detach and mail the completed order form with credit card information, money order, or check in U.S. currency (made payable to Thomson Consumer Electronics, Inc.) to the following address:

Video Accessories
PO Box 8419
Ronks, PA 17573

Care and Maintenance

Keep dust and grit from entering the camcorder's cassette door. Dust and grit are abrasive and cause excessive wear to both the camcorder's recording and playback heads and cassettes.

Do not use strong or abrasive detergents when cleaning your camcorder. They may damage the camcorder.

Before handling your camcorder, make sure your hands and face are free from any chemical products such as suntan lotion, as it may damage the finish.

Do not touch the lens with your fingers! The oil from your skin may damage the lens. To clean the lens, always use lens-cleaning tissues and a commercially prepared cleaning solution designed for use on camera lens.

Always replace the lens cap on the lens when the camcorder is not in use.

The camcorder can be damaged by improper storage or handling. Do not subject the camcorder to swinging, shaking, or dropping.

Do not store the camcorder in temperatures below -22°F (-30°C) or above 149°F (65°C).

When the camcorder is not in use, always remove the cassette and AC adapter/charger or battery.

Retain the original carton for future storage or shipping purposes.

Things to Avoid

Do not aim your camcorder at the sun or other bright objects or leave your camcorder in direct sunlight. Doing so could permanently damage the camcorder's internal parts.

Avoid operating your camcorder after moving it from a cold location to a warm location. Moisture may cause the tape to stick to the headwheel and damage the headwheel or tape. Give the camcorder 2 to 3 hours to reach a stable temperature before inserting a cassette.

Do not operate or leave your camcorder in extremely humid environments.

Do not operate the camcorder for extended periods in temperatures below 40°F (4°C) or above 95°F (35°C).

Do not expose the camcorder or adapter/charger to rain or moisture. If either component becomes wet, turn off the power and take the unit to an Authorized RCA Camcorder Servicenter.

Care and Maintenance

Cleaning the Camcorder

To clean the camcorder's exterior, remove any power source connected to the camcorder and gently wipe it with a clean soft cloth.

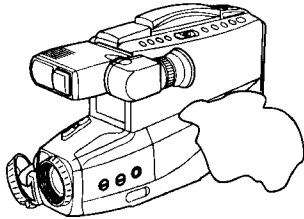

Caution: Use of strong cleaning products, such as those containing alcohol or benzine, may damage the camcorder.

Cleaning the Camcorder's Lens

To clean the camcorder's lens, blow it with a blower brush, and then gently wipe the lens with cleaning tissue and commercially prepared cleaning solution designed for use on camera lens. Improper cleaning may scratch the lens.

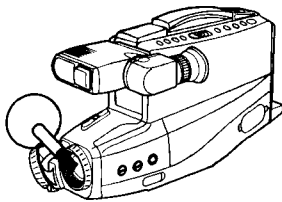

Caution: Do not touch the lens with your fingers. The oil from your skin can damage the lens.

Cleaning the Camcorder's Viewfinder

The viewfinder eyepiece can be removed for cleaning.

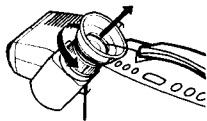

1. Turn the eyepiece counterclockwise and pull it out.

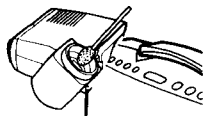

2. Gently use a cotton swab or blower brush to remove the dust.

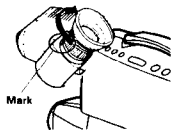

3. Reattach the eyepiece by aligning the reference marks, and then turn the eyepiece clockwise.

Trouble Checks

Troubles sometimes are caused by simple “faults” that you can easily correct without the help of a service technician by first checking a few basic remedies.

Before you call or take your camcorder to an Authorized RCA Camcorder Servicenter, look below for the type of trouble you are experiencing. Then perform the simple checks and adjustments listed for that trouble.

Trouble	Checks and Adjustments
No Power	<ul style="list-style-type: none">• If using the rechargeable battery, it may need recharging.• If using the AC adapter/charger, make sure it is plugged into a working AC outlet.
Will Not Record or Play Back	<ul style="list-style-type: none">• Make sure there is a cassette in the camcorder.• Try ejecting and re-inserting the cassette.• The cassette tape is broken — try another cassette.• You have reached the end of the cassette — try rewinding it.• Moisture condensation may cause the tape to stick to the headwheel and damage the headwheel or tape. Give the camcorder 2 to 3 hours to reach a stable temperature before re-inserting a cassette.
Will Not Play Back	<ul style="list-style-type: none">• <i>CAMERA/OFF/VCR</i> switch must be in <i>VCR</i>.
Will Not Record	<ul style="list-style-type: none">• Safety tab has been removed from cassette. See page 16.• <i>CAMERA/OFF/VCR</i> switch must be in <i>CAMERA</i>.• <i>A/V OUT/IN</i> switch must be in <i>OUT</i> to record on the camcorder.
No Picture in Viewfinder	<ul style="list-style-type: none">• Make sure the lens cap has been removed.
Tape Does Not Rewind or Fast Forward	<ul style="list-style-type: none">• Make sure titler graphics do not appear in viewfinder. Press <i>TITLER</i> to remove them.

Trouble Checks

Trouble	Checks and Adjustments
Tape Stops During Rewind or Fast Forward	<ul style="list-style-type: none"> • The tape counter's memory-stop feature may be turned on. When an "M" appears behind the tape-counter display, the camcorder will stop rewinding or fast-forwarding when the counter reads "0000M". Press the <i>REW/REVIEW</i> or <i>F.FWD</i> button again to continue, or press <i>DISPLAY</i> to turn off memory stop.
Camcorder Remains in Play Pause	<ul style="list-style-type: none"> • Press <i>REC/PAUSE</i> to return to normal playback.
Poor Picture Quality During Recording	<ul style="list-style-type: none"> • There is insufficient light. Add more light. • Use the color enhancement light to add more light. <i>Details are on pages 50-51.</i>
Viewfinder Displays Are Out of Focus	<ul style="list-style-type: none"> • Try adjusting the eyepiece focus control. <i>Details are on page 22.</i>
Poor Auto-Focus Operation	<ul style="list-style-type: none"> • Lens may be smudged and image appears unfocused. • Viewfinder eyepiece focus or <i>BRIGHT</i> control may be adjusted incorrectly. <i>Details are on pages 22-23.</i>
Poor Picture Quality During Playback	<ul style="list-style-type: none"> • Tape was recorded on a different camcorder or VCR. If the picture contains black-and-white streaks, press one of the <i>TRACKING</i> buttons to correct. • Camcorder only has one speed (SP). If the tape was recorded on a different VCR at a different speed, it cannot be played back in this camcorder.
Recorded Audio is Too Low	<ul style="list-style-type: none"> • Subject may have been too far from the camcorder.

Trouble Checks

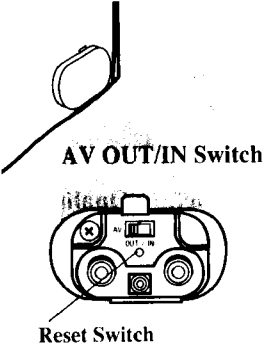
Trouble	Checks and Adjustments
AE Shutter-Speed or INDEX Indicator Does Not Appear in Viewfinder	<ul style="list-style-type: none"> • <i>CAMERA/OFF/VCR</i> switch must be in <i>CAMERA</i>, and press <i>DISPLAY</i> to display the indications.
Date and Time (or Date) were Recorded on the Tape	<ul style="list-style-type: none"> • Date and time (or date) will be recorded on the tape whenever they appear in the viewfinder. Press <i>DATE/TIME</i> to remove them from the viewfinder when recording.
Date and Time Appear Incorrect	<ul style="list-style-type: none"> • Make sure the date and time have been set. <i>Details on page 26.</i> • The camcorder's internal clock battery may need recharging. <i>Details on page 27.</i>
Camcorder Does Not Turn On and/or Function Buttons Will Not Operate	<ul style="list-style-type: none"> • Remove the power source. After one minute press the reset switch gently using a non-metallic pointed item, such as a toothpick, until you feel a click. This resets the camcorder to the factory settings and erases the date, time, and custom settings. <p>Note: When connecting a power source again, wait for about one minute after the reset switch is pressed.</p> <div data-bbox="808 659 1075 1010" style="text-align: center;">  <p>The diagram consists of two parts. The top part shows a close-up of a small, rectangular switch with a vertical tab, labeled "AV OUT/IN Switch". The bottom part shows a top-down view of the camcorder's control panel, with a small, circular button labeled "Reset Switch" indicated by a line pointing to it.</p> </div>

Limited Warranty

What your warranty covers:

- Any defect in material or workmanship.

For how long after your purchase:

- Ninety days for labor charges.
- One year for parts.
The warranty period for rental units begins with the first rental.

What we will do:

- Pay any Authorized RCA Camcorder Servicenter the labor charges to repair your camcorder.
- Pay any Authorized RCA Camcorder Servicenter for the new or, at our option, refurbished replacement parts required to repair your camcorder.

How you get service:

- Check with your RCA Camcorder Dealer or call 1-800-336-1900 for the Authorized RCA Camcorder Servicenter nearest you. State that you have an RCA camcorder.

If an Authorized RCA Camcorder Servicenter is conveniently near you:

- Take your camcorder to the Authorized RCA Camcorder Servicenter of your choice.
- Show the service center representative your sales receipt or other evidence of purchase date.
- Pick up your camcorder when repairs are completed.

If an Authorized RCA Camcorder Servicenter is not located conveniently near you:

- Pack the camcorder so that it will not be damaged during shipping. (We recommend using the original carton and packing materials.) Include any cables and other accessories originally furnished with the camcorder.
- Include in the camcorder carton (1) a copy of your sales receipt or other evidence of purchase date, (2) your

name and address, and (3) a brief description of the problem.

- Ship the camcorder to an Authorized RCA Camcorder Servicenter.
- Pay any charges billed to you by the Servicenter for service not covered by the warranty.

What your warranty *does not* cover:

- Customer instruction. (Your owner's manual clearly describes how to install, adjust, and operate your camcorder. Any additional information should be obtained from your dealer.)
- Installation and related adjustments.
- Cleaning of video/audio heads.
- Damage from misuse or neglect.
- Battery for clock or other features.
- A camcorder that has been modified or incorporated into other products or is used for institutional or other commercial purposes.
- A camcorder purchased or serviced outside the USA.
- Acts of God, such as but not limited to lightning damage.

Product Registration:

- Please complete and mail the *product registration card* packed with your camcorder. It will make it easier to contact you should it ever be necessary. The return of the card is not required for warranty coverage.

How state law relates to this warranty:

- This warranty gives you specific legal rights and you also may have other rights that vary from state to state.

If you purchased your camcorder outside the United States:

- This warranty does not apply. Contact your dealer for warranty information.

Index

- A.(Audio) *DUB* Indicator24,35,37
- A/V *DUB* Indicator24,37
- Accessories, Included3
- Accessories, Optional54-61
- Accessory Lens, Attaching57
- Accessory Order Form59-61
- Adapter/Charger, Using4,10
- Adjustments and Checks64-66
- AE* Displays20,24
- AI (Artificial Intelligence)19
- Assistance67
- Attaching Adapter/Charger4,10
- Attaching the Rechargeable Battery . .12
- Attaching the Shoulder Strap52
- Audio Dubbing34-35
- Audio/Video Dubbing35-37
- AUDIO/VIDEO* Jacks
.8,34-37,42-43,46,48
- AUTO* Date Display27
- AV* (Audio/Video) *OUT/IN* Switch
.8,34-37,42-43,46,48
- AV DUB* Button8,25,35,37
- Battery, Attaching and Removing . . .12
- Battery Care and Storage13
- Battery Charging11
- Battery, Clock27
- BATTERY EJECT* Lever9,12
- Battery Level Indicator14,24-25
- Battery, Rechargeable11-14
- Battery Safety Precautions13
- BRIGHT* Control23
- Bulb Replacement, Video Light51
- Camcorder, Cleaning63
- Camcorder Operating Controls8-9
- Camcorder, Powering10-15
- Camcorder, Recording On From a
VCR or *TV Monitor*42-43
- Camcorder, Unpacking3
- CAMERA/OFF/VCR* Switch . .5,7,12,19,
.26-27,35,37,38-40,43,44,47,49
- Car Cord, Optional15,55
- Card, Registrationi
- Care and Maintenance62-63
- Care and Storage, Battery13
- Care and Storage, Cassettes17
- Carrying Case, Packing53
- Cassette Door9,17
- Cassette, Inserting and Removing . .6,17
- Cassette Tips18
- Cassettes, Video16-17
- Charging the Battery11
- Chart of Title Characters39
- Checking Battery Power14
- Checks and Adjustments64-66
- Cleaning the Camcorder63
- Clock Battery, Charging27
- Color Enhancement Light50-51
- Contents1-2
- Copying Tapes42-43,46-47
- Correcting the Date and Time26
- Customer Assistance .1,3,67,Back Cover
- Date and Time Displays . . .24-25,26-27
- Date and Time Recording27
- DATE/TIME* Button8,25,26-27
- DC IN 9.6V* Jack9
- Design Specifications54
- DISPLAY* Button8,24-25,32
- Dubbing34-37
- Edit Search33
- EDIT—ADV* Button8,38-40
- Electronic Indexing21
- Erase Protection16
- Eyepiece Focus Control6,8,22
- F.FWD* Button . .8,19,26,32,33,35,37,45
- FADE* Button8,24,31
- FADE* Indicators24,31
- Fading31
- First-Time Operation3-9
- Flying Erase Head33
- Focus, Auto and Macro20
- Handstrap5,9
- INDEX* Indicator21,24-25
- Indexing, Electronic21
- Information to User53
- Lens Hood8
- Lens Cap Holder*9
- Lens Cap, Remove5
- Lens Hood, Removing8,57
- Lens, Cleaning63
- LIGHT AUTO/OFF/ON* Switch . . .8,50
- Light Bulb, Replacing51
- Light, Built-in8,50-51
- Limited Warranty67
- Maintenance and Care62-63
- Memory Stop Feature32
- Microphone8,19
- NO TAPE* Indicator24-25
- Operating Controls, Camcorder8-9

Index

- Operation, First-Time 3-9
- Optional Accessories 54-61
- Optional Car Cord 15,55
- Order Form, Accessories 59-61
- PAUSE Indicator 35,37
- Picture Search 45
- PLAY Button 7,8,33,35,37,44,47,49
- Playback on a TV with
 - AUDIO/VIDEO IN Jacks 46-47
- Playback on a TV
 - without Audio/Video Inputs 48-49
- Playback, First 7
- Playback, Viewfinder 44
- Plug Adapter, Optional 10
- Power Zoom Buttons 24-25,28
- Powering Your Camcorder 10-15
- Problem Solving 64-66
- Product Registration i
- ProEdit Features 33-40
- Program AE (Auto Exposure) 20
- Quick Review 19
- REC Indicator 7,24
- REC/PAUSE Button
 - 7,9,31,32,35,37,40,45,47,49
- Rechargeable Battery 11-14
- Recording Date and Time 27
- Recording on the Camcorder 42-43
- Recording Speed 16
- Recording Tips 41
- Recording Titles 40
- Recording, First 7
- Registration Card i
- Removing Lens Hood 57
- Removing the Rechargeable Battery 12
- Replacing Bulb of Video Light 51
- RESET Button 8,32
- REVIEW Button 8,19
- REW (Rewind) Button
 - 7,8,19,26,32,33,35,37,45
- RF DC OUT Jack 8,48
- RF Output Adapter 48-49,56
- Safety Information i
- Safety Precautions, Battery 13
- Safety Tab 16
- Set the Date and Time 26
- Shoulder Strap Attachment Rings 9,52
- Shoulder Strap, Attaching 52
- Solving Problems 64-66
- SP (Standard Play) Speed 16
- Specifications 54
- Status Displays 24
- Stop Action Pause 45
- STOP/EJECT Button
 - 6,7,8,17,19,26,32,35,37,47,49
- Tab, Safety 16
- Table of Contents 1-2
- TAPE END Indicator 24-25
- TAPE Indicator 24-25
- Tape Copying 42-43,46-47
- Tape Counter 24,32
- Tape Positioning 19
- Things to Avoid 62
- Tilt Adjustment 23
- Time and Date Display 24-25,26,27
- Time and Date Recording 27
- Time Remaining Display 21,25
- Tips, Cassette 18
- Tips, Recording 41
- Tips, Traveling 18
- Title Select + and - Buttons 8,38-40
- Title Select Button 8,38-40
- TITLER Button 8,38-40
- Titler 38-40
- TRACKING (Also Power Zoom)
 - Buttons 44,45
- Traveling Tips 18
- Tripod, Using 58
- Trouble Checks 64-66
- Unpacking the Camcorder 3
- Using a Tripod 58
- Using Adapter/Charger 10
- Using the Rechargeable Battery 11-14
- VIDEO/AUDIO Jacks
 - 8,34-37,42-43,46,48
- Video Cassettes 16-17
- Video Light 50-51
- Viewfinder 6,8,22-23,44,63
- Viewfinder Playback 44
- Viewfinder, Cleaning 63
- Warranty, Limited 67
- Zoom Buttons 9,28
- Zoom Level Control 24,28
- Zooming 28

Need Assistance? We want to help!

U.S. Consumers:

Customer Service800-336-1900
Accessories800-338-0376

Canadian Consumers:

English800-522-0338
French800-522-0445

Please do not send any products to the Indianapolis address listed in this manual or on the carton. This will only add delays in service for your product.

THOMSON CONSUMER ELECTRONICS

**10330 N Meridian Street
Indianapolis, IN 46290**

©1996 Thomson Consumer Electronics, Inc.
Trademark(s)® Registered
Marca(s) Registrada(s)
Printed in Japan
Part Number 96-CC437-1
QR14433