



# ROOM AIR CONDITIONER

**SAFETY INFORMATION** .....3

**USING THE AIR CONDITIONER**

Controls .....4

Remote Control .....4

**CARE AND CLEANING** .....7

**INSTALLATION INSTRUCTIONS**

Window .....8

Through-The-Wall - Optional.....14

**TROUBLESHOOTING TIPS**.....15

**CONSUMER SUPPORT**

Warranty .....17

Consumer Support.....18

## OWNER'S MANUAL & INSTALLATION INSTRUCTIONS

AEE18

Write the model and serial numbers here:

Model # \_\_\_\_\_

Serial # \_\_\_\_\_

You can find the rating label on the side of the air conditioner.

## **THANK YOU FOR MAKING GE APPLIANCES A PART OF YOUR HOME.**

---

Whether you grew up with GE Appliances, or this is your first, we're happy to have you in the family.

We take pride in the craftsmanship, innovation and design that goes into every GE Appliances product, and we think you will too. Among other things, registration of your appliance ensures that we can deliver important product information and warranty details when you need them.

Register your GE appliance now online. Helpful websites and phone numbers are available in the Consumer Support section of this Owner's Manual. You may also mail in the pre-printed registration card included in the packing material.



**GE APPLIANCES**

# IMPORTANT SAFETY INFORMATION

## READ ALL INSTRUCTIONS BEFORE USING THE APPLIANCE

**▲ WARNING** For your safety, the information in this manual must be followed to minimize the risk of fire, electric shock or personal injury.

- Use this appliance only for its intended purpose as described in this Owner's Manual.
- This air conditioner must be properly installed in accordance with the Installation Instructions before it is used.
- Never unplug your air conditioner by pulling on the power cord. Always grip plug firmly and pull straight out from the receptacle.
- Replace immediately all electric service cords that have become frayed or otherwise damaged. A damaged power supply cord must be replaced with a new power supply cord obtained from the manufacturer and not repaired. Do not use a cord that shows cracks or abrasion damage along its length or at either the plug or connector end.
- Turn the unit OFF and unplug your air conditioner before cleaning.
- GE Appliances does not support any servicing of the air conditioner. We strongly recommend that you do not attempt to service the air conditioner yourself.
- For your safety...do not store or use combustible materials, gasoline or other flammable vapors or liquids in the vicinity of this or any other appliance.
- All air conditioners contain refrigerants, which under federal law must be removed prior to product disposal. If you are getting rid of an old product with refrigerants, check with the company handling disposal about what to do.
- If the receptacle does not match the plug, the receptacle must be changed out by a qualified electrician.
- These R410A air conditioning systems require contractors and technicians to use tools, equipment and safety standards approved for use with this refrigerant. DO NOT use equipment certified for R22 refrigerant only.

**▲ WARNING** USE OF EXTENSION CORDS

**RISK OF FIRE. Could cause serious injury or death.**

- DO NOT use an extension cord with this Window Air Conditioner.
- DO NOT use surge protectors or multi-outlet adaptors with this Window Air Conditioner.

### HOW TO CONNECT ELECTRICITY

Do not, under any circumstances, cut or remove the third (ground) prong from the power cord. For personal safety, this appliance must be properly grounded.

**DO NOT use an adapter plug with this appliance.**

The power cord of this appliance is equipped with a 3-prong (grounding) plug which mates with a standard 3-prong (grounding) wall outlet to minimize the possibility of electric shock hazard from this appliance.

Power cord includes a current interrupter device. A test and reset button is provided on the plug case. The device should be tested on a periodic basis by first pressing the **TEST** button and then the **RESET** button while plugged into the outlet. If the **TEST** button does not trip or if the **RESET** button will not stay engaged, discontinue use of the air conditioner and contact a qualified service technician.

Have the wall outlet and circuit checked by a qualified electrician to make sure the outlet is properly grounded.

Where a 2-prong wall outlet is encountered, it is your personal responsibility and obligation to have it replaced with a properly grounded 3-prong wall outlet.

The air conditioner should always be plugged into its own individual electrical outlet which has a voltage rating that matches the rating plate.

This provides the best performance and also prevents overloading house wiring circuits which could cause a fire hazard from overheated wires.

See the Installation Instructions, **Electrical Requirements** section for specific electrical connection requirements.

**▲ WARNING** Chemical Burn Hazard. Keep batteries away from children.

- This product contains a lithium button/coin cell battery. If a new or used lithium button/coin cell battery is swallowed or enters the body, it can cause severe internal burns and can lead to death in as little as 2 hours. Always completely secure the battery compartment. If the battery compartment does not close securely, stop using the product, remove the batteries, and keep it away from children.
- If you think batteries might have been swallowed or placed inside any part of the body, seek immediate medical attention.
- The cells shall be disposed of properly, including keeping them away from children.
- Even used cells may cause injury.

## READ AND SAVE THESE INSTRUCTIONS

# Controls

Features and appearance will vary.

Lights beside the touch pads on the air conditioner control panel indicate the selected settings.

NOTE: The display always shows the room temperature except when setting the Set temperature or the Delay timer.

Light indicates the unit is in the temperature or delay time Set mode.

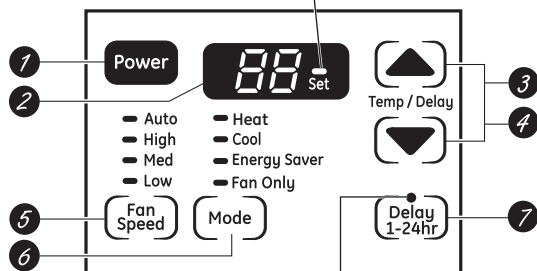

Light indicates the delay timer is set.

**Air Conditioner Controls**

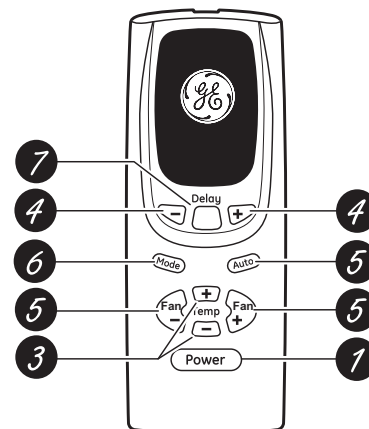

**Remote Control**

1. **Power Pad**  
Turns air conditioner on and off. When turned on, the display will show the room temperature.
2. **Display**  
Displays the set temperature while in **Heat**, **Cool** or **Energy Saver** mode. Displays the room temperature while in Fan mode. Show time remaining in hours when in Delay mode.
3. **Temp Increase ▲ /Decrease ▼ pads**  
Use to set temperature when in **Heat**, **Cool** or **Energy Saver** mode. The **Set** light will turn on while setting.
4. **Delay Timer Increase▲ (+) /Decrease ▼(-) Pads**  
Each touch of the **Increase ▲ / Decrease ▼** pads on the unit or the **Increase + / Decrease -** pads on the remote control will set the delay time when using the **Delay 1–24hr** timer. The **Set** light will turn on while setting.
5. **Fan Speed Pad**  
Use to set the fan speed to **Low**, **Med**, **High** or **Auto** on the unit. **NOTE:** On the remote control, use the fan speed **Increase + / Decrease -** pads to set the fan speeds to **Low**, **Med** or **High**. Use the **Auto** pad to turn **Auto** fan on.
6. **Mode Pad**  
**Delay ON**—When the air conditioner is off, it can be used to set the air conditioner to **Heat**, **Cool**, **Energy Saver** or **Fan Only** mode.

7. **Delay Pad**  
**Delay ON**—When the air conditioner is off, it can be set to automatically come on in 1 to 24 hours at its previous mode and fan settings.

**Delay OFF**—When the air conditioner is on, it can be set to automatically turn off in 1 to 24 hours.

**How to set:**

Press the **Delay 1–24hr** pad on the unit or on the remote control. Each touch of the **Increase ▲ / Decrease ▼** pads on the unit or the **Increase + / Decrease -** pads on the remote control will set the timer in 1-hour intervals. The **Set** light will turn on while setting.

To review the remaining time on the **Delay 1–24hr** timer, press the **Delay 1–24hr** pad on the unit or on the remote control. Use the **Increase ▲ / Decrease ▼** pads on the unit or the **Increase + / Decrease -** pads on the remote control to set a new time if desired.

**To cancel the timer**, press the **Delay 1–24hr** pad until the light on the **Delay 1–24hr** pad goes off.

**Note:** The default temperature reading on the display is degree Fahrenheit ( °F). To change the display to degree Celcius (°C), press the Temp Increase ▲ and Temp Decrease ▼ buttons together and hold for 3 seconds. Repeat the process to change back to degree Fahrenheit (°F)

# Using the Air Conditioner

## Heat Mode

Use the **Heat** mode at **Low, Med, High** or **Auto Fan Speed** for heating. Use the **Temperature Increase ▲ / Decrease ▼** pads to set the desired temperature between 61°F and 86°F in 1°F increments.

An electronic thermostat is used to maintain the room temperature. The heater will cycle on and off to keep the room at the set level of comfort.

## Cool Mode

Use the **Cool** mode at **Low, Med, High** or **Auto Fan Speed** for cooling. Use the **Temperature Increase ▲ / Decrease ▼** pads to set the desired temperature between 61°F and 86°F in 1°F increments.

a **Cool** setting, it may take approximately 3 minutes for the compressor to start and cooling to begin.

### Cooling Descriptions

**For Normal Cooling**—Select the **Cool** mode and **High** or **Med** fan with a middle set temperature.

**For Maximum Cooling**—Select the **Cool** mode and **High** fan with a lower set temperature.

**For Quieter and Nighttime Cooling**—Select the **Cool** mode and **Low** fan with a middle set temperature.

An electronic thermostat is used to maintain the room temperature. The compressor will cycle on and off to keep the room at the set level of comfort. Set the thermostat at a lower number and the indoor air will become cooler. Set the thermostat at a higher number and the indoor air will become warmer.

**NOTE:** If the air conditioner is off and is then turned on while set to a **Cool** setting or if turned from a fan setting to

## Energy Saver Mode

Controls the fan.

**ON**—The fan will cycle on and off with the compressor. This results in wider variations of room temperature and humidity. Normally used when the room is unoccupied.

**NOTE:** The fan may continue to run for a short time after the compressor cycles off.

**OFF**—The fan runs all the time, while the compressor cycles on and off.

## Fan Only Mode

Use the Fan Only Mode at Low, Med or High fan speed to provide air circulation and filtering without cooling. Since fan-only settings do not provide cooling, a Set temperature cannot be entered. The room temperature will appear in the display.

**NOTE:** Auto Fan Speed cannot be used when in the **Fan Only** Mode.

## Auto Fan Speed

Set to **Auto** fan speed for the fan speed to automatically set to the speed needed to provide optimum comfort settings with the set temperature.

If the room needs more cooling, the fan speed

will automatically increase. If the room needs less cooling, the fan speed will automatically decrease.

**NOTE:** Auto Fan Speed cannot be used when in the **Fan Only** Mode.

## Remote Control

- To ensure proper operation, aim the remote control at the signal receiver on the air conditioner.
- Make sure nothing is between the air conditioner and the remote control that could block the signal.

- The remote control signal has a range of up to 20 feet.
- Make sure batteries are fresh and installed correctly as indicated on the remote control.
- Remote contains a magnet allowing it to attach to metal surfaces.

## Power Outage Recovery Feature

In the case of a power outage or interruption, the unit will automatically re-start in the settings last used after the power is restored. If the Delay 1–24hr feature was set, it

will resume countdown. You may need to set a new time if desired.

## Using the Air Conditioner

### Air Direction

Use the lever to adjust the air direction left and right only. Fingertip pressure on the horizontal louvers adjusts the air direction up or down.

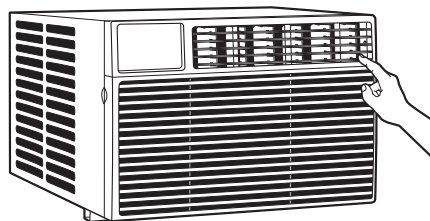

## Care and Cleaning

### Grille and Case

Turn the air conditioner off and remove the plug from the wall outlet before cleaning.

To clean, use water and a mild detergent. Do not use bleach or abrasives.

### Air Filter

The air filter behind the front grille should be checked and cleaned at least every 30 days or more often if necessary.

#### To remove:

Open the inlet grille by pulling downward on the tabs at the top upper corners of the inlet grille until the grille is in a 45° position. Remove the filter.

Clean the filter with warm, soapy water. Rinse and let the filter dry before replacing it. Do not clean the filter in a dishwasher.

**CAUTION** DO NOT operate the air conditioner without a filter because dirt and lint will clog it and reduce performance.

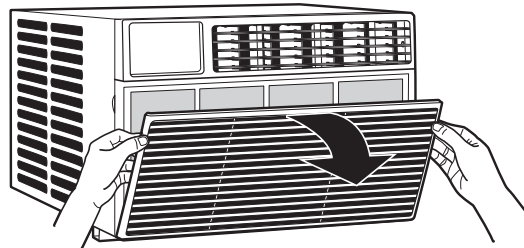

### Outdoor Coils

The coils on the outdoor side of the air conditioner should be checked regularly. If they are clogged with dirt or soot, they may be professionally cleaned.

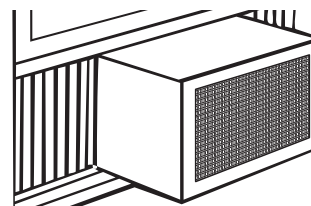

### How to Insert the Batteries in the Remote Control

1. Remove the battery cover by sliding it according to the arrow direction.
2. Insert new batteries, making sure that the (+) and (-) of battery are installed correctly.
3. Reattach the cover by sliding it back into position.

#### NOTES:

- Use 2 “AAA” (1.5 volt) alkaline batteries. Do not use rechargeable batteries.
- Remove the batteries from the remote control if the system is not going to be used for a long time.
- Do not mix old and new batteries. Do not mix alkaline, standard (carbon-zinc) or rechargeable (ni-cad, ni-mh, etc) batteries.

# Installation Instructions

Questions? Visit our Website at: [GEAppliances.com/service](http://GEAppliances.com/service)

## BEFORE YOU BEGIN

Read these instructions completely and carefully.

- **IMPORTANT** — Save these instructions for local inspector's use.
- **IMPORTANT** — Observe all governing codes and ordinances.
- **Note to Installer** — Be sure to leave these instructions with the Consumer.
- **Note to Consumer** — Keep these instructions for future reference.
- **Skill level** — Installation of this appliance requires basic mechanical skills.
- **Completion time** — Approximately 1 hour
- We recommend that two people install this product.
- Proper installation is the responsibility of the installer.
- Product failure due to improper installation is not covered under the Warranty.
- You **MUST** use all supplied parts and use proper installation procedures as described in these instructions when installing this air conditioner.

## ELECTRICAL REQUIREMENTS

 The 3-prong grounding plug minimizes the possibility of electric shock hazard. If the wall outlet you plan to use is only a 2-prong outlet, it is your responsibility to have it replaced with a properly grounded 3-prong wall outlet.

These models require 230/208-volt AC, protected with a time-delay fuse or circuit breaker. These models should be installed on their own single branch circuit for best performance and to prevent overloading house or apartment wiring circuits, which could cause a possible fire hazard from overheating wires.

Power cord includes a current interrupter device. A test and reset button is provided on the plug case. The device should be tested on a periodic basis by first pressing the **TEST** button and then the **RESET** button while plugged into the outlet. If the **TEST** button does not trip or if the **RESET** button will not stay engaged, discontinue use of the air conditioner and contact a qualified service technician.

## ELECTRICAL REQUIREMENTS (CONT)

### CAUTION

Do not, under any circumstances, cut or remove the third (ground) prong from the power cord.

Do not change the plug on the power cord of this air conditioner.

Aluminum house wiring may present special problems—consult a qualified electrician.

Power cord includes a current interrupter device. A test and reset button is provided on the plug case. The device should be tested on a periodic basis by first pressing the **TEST** button and then the **RESET** button while plugged into the outlet. If the **TEST** button does not trip or if the **RESET** button will not stay engaged, discontinue use of the air conditioner and contact a qualified service technician.

## TOOLS YOU WILL NEED

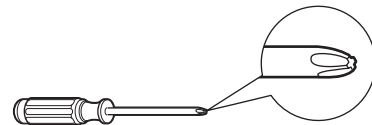

Phillips head screwdriver



Flat-blade screwdriver



Pencil

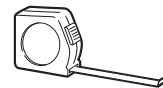

Ruler or tape measure



Level

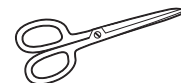

Scissors or knife

# Installation Instructions

## PARTS INCLUDED (Appearance may vary)

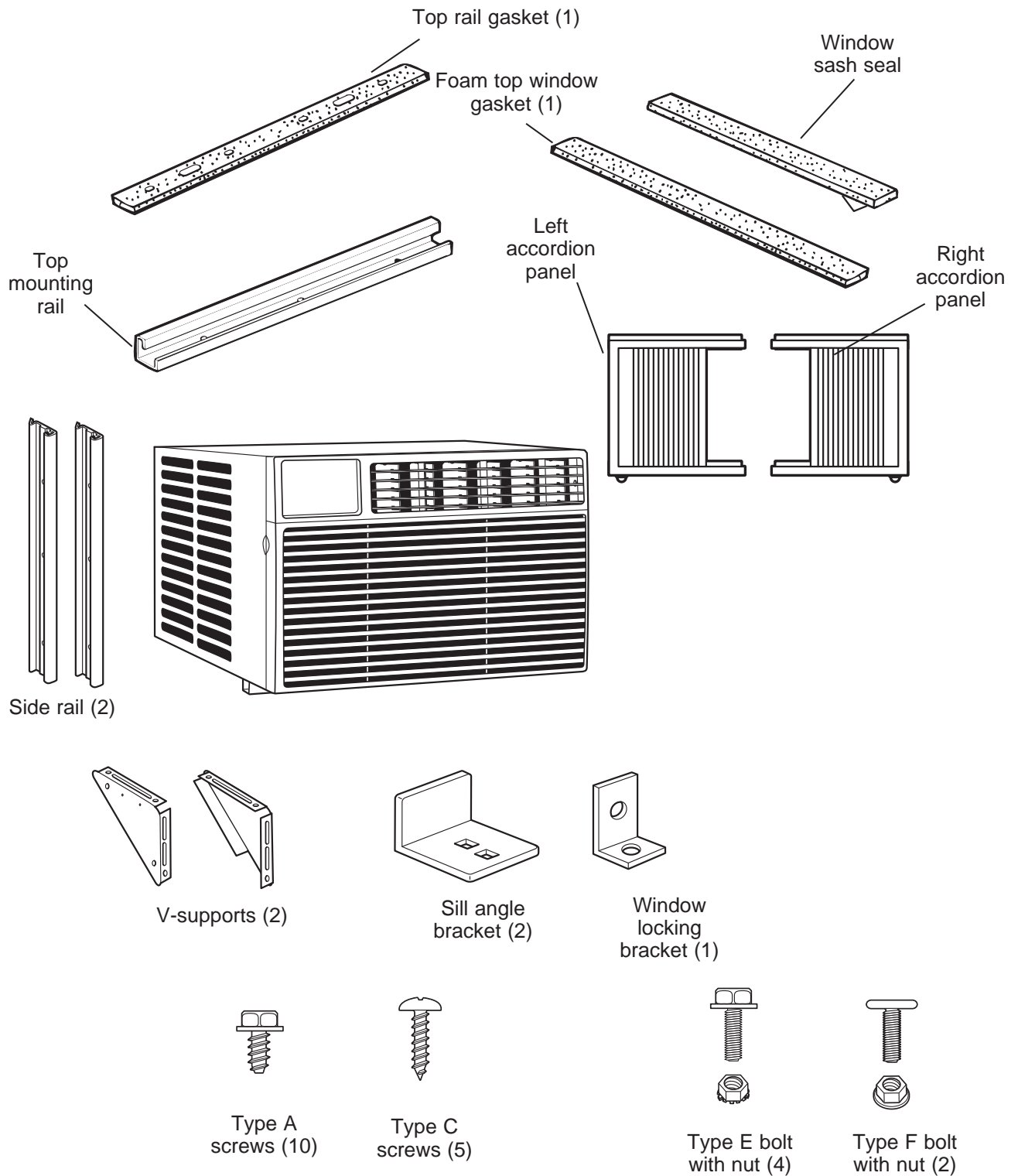



# Installation Instructions

## 1. WINDOW REQUIREMENTS

- These instructions are for a standard double-hung window. You will need to modify them for other types of windows.
- The air conditioner can be installed without the side curtain panels if needed to fit in a narrow window. See the window opening dimensions.
- All supporting parts must be secured to firm wood, masonry or metal.
- The electrical outlet must be within reach of the power cord.
- Follow the dimensions in the illustration for your model.

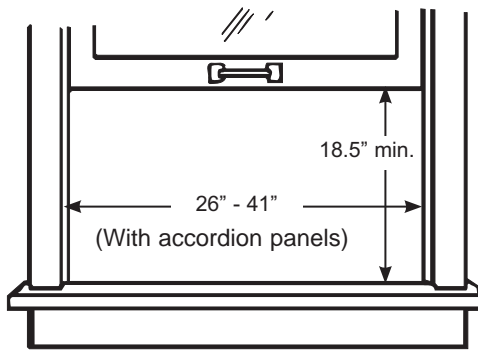

## 2. STORM WINDOW REQUIREMENTS

A storm window frame will not allow the air conditioner to tilt toward the outside, and will keep it from draining properly. To adjust for this, attach a piece of wood to the sill.

### WOOD PIECES

**WIDTH:** 2"

**LENGTH:** Long enough to fit inside the window frame.

**THICKNESS:** To determine the thickness, place a piece of wood on the sill to make it 1/2" higher than the top of the storm window frame or the vinyl frame.

Attach securely with nails or screws provided by the installer.

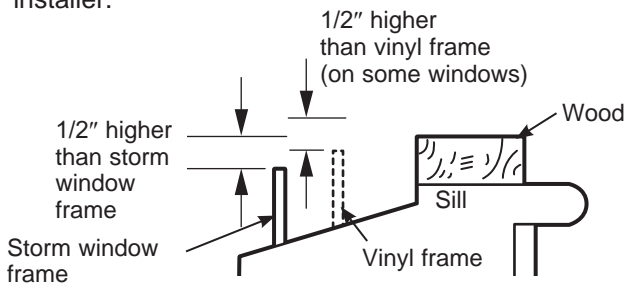

## 3. PREPARE THE AIR CONDITIONER

- A.** Pull the top of the front panel out and down. Remove the filter. Remove the front panel by lifting up at an angle.

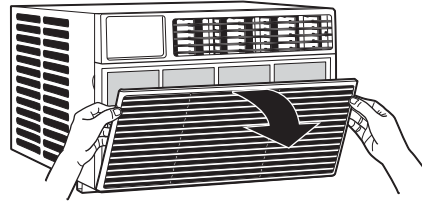

- B.** Remove the four front screws. Save them for reinstalling the front housing.

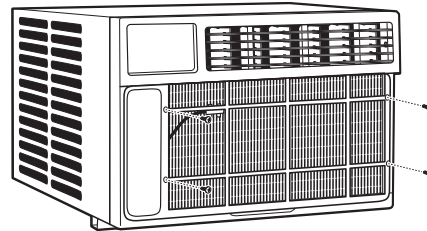

- C.** Grasp the lower corners of the grille while pressing in on the case sides with your finger tips. Pull out to release and lift it up.

**NOTE:** Do not pull the bottom edge toward you more than 3" or you may damage the tabs of the grille.

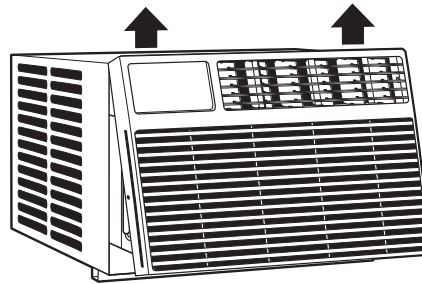

- D.** When the front grille is removed the control panel will still be attached by a harness. Turn the grille around so you can see the back side of the grille. Remove the 2 screws to separate the control panel housing from the grille.

**NOTE:** Be sure to save these screws. You will need them later in the installation.

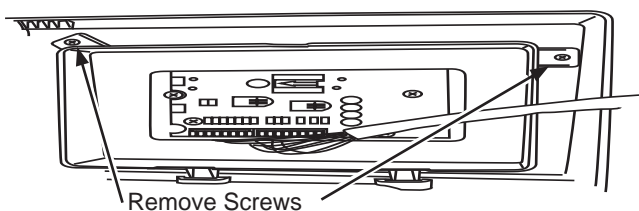

# Installation Instructions

## 3. PREPARE THE AIR CONDITIONER

E. Remove the shipping screws located on the top of the case.

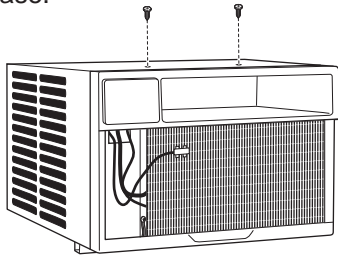

F. Remove the ground screws from each side of the case. Keep them in a safe location.

**NOTE:** Be sure to save the ground screws. You will need them later in the installation.

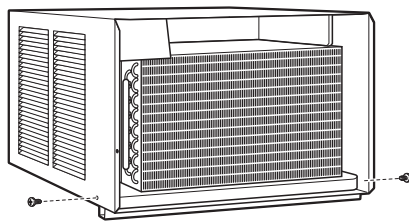

G. Slide the air conditioner from the case by gripping the base pan handle, lifting up on the air conditioner, and pulling forward. Have a second person brace the case. Do not pull or lift on the styrofoam discharge area.

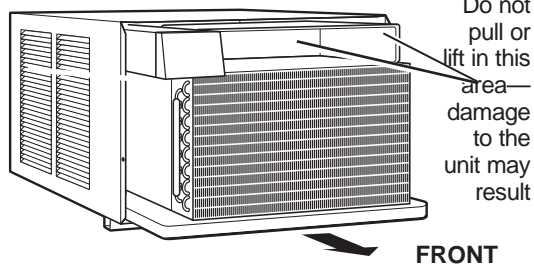

H. When the front grille is removed the control panel will still be attached by a harness. Turn the grille around so you can see the back side of the grille. Remove the 2 screws to separate the control panel housing from the grille.

**NOTE:** Be sure to save these screws. You will need them later in the installation.

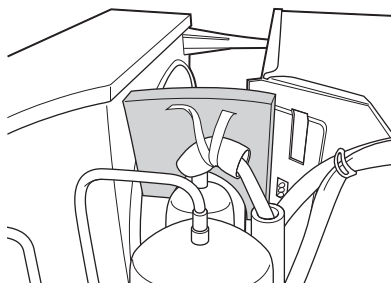

## 4. PREPARE THE CASE

A. Attach the top rail gasket to the bottom of the top mounting rail.

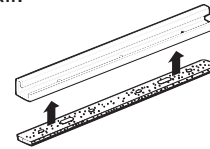

B. Install the top mounting rail with 4 type A screws from the inside of the case. Press firmly to drive the screws into the gasket and through the top mounting rail.

Top mounting rail

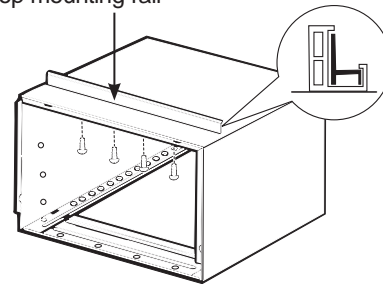

C. Slide each side rail onto the edge of each according panel. The figure shows the orientation of each accordion panel and side retainer assembly relative to the case from a top view of the unit.

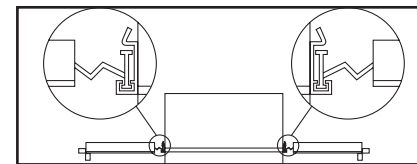
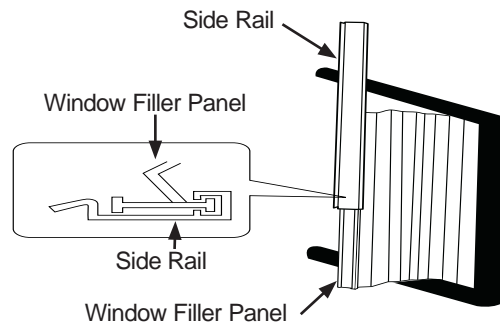

D. Slide the left and right accordion panels into the top and bottom mounting rails.

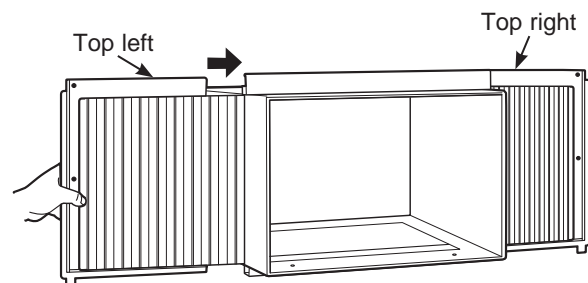

# Installation Instructions

## 4. PREPARE THE CASE (cont)

- E. Attach the side retainers to the case using 6 type A screws. Mount the screws from the inside of the wall case.

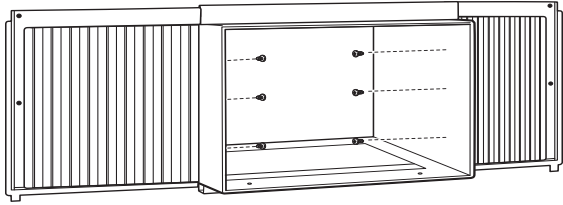

## 5. PREPARE THE WINDOW AND INSTALL THE CASE

- A. Cut the window sash seal to the length of the window sash. Peel off the backing and attach the seal to the underside of the window sash.

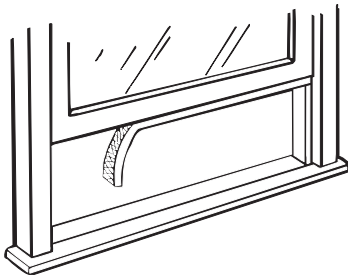

- B. Open the window and mark the center of the window sill.

- C. Carefully slide the case into the window and center the case. Lower the window behind the top mounting rail. Pull the bottom of the case forward so that the bottom mounting rail is tight against the back of the window sill. Mount the case to the window sill using 2 type C screws. Drill pilot holes, if necessary.

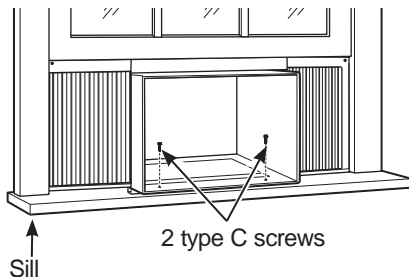

## 5. PREPARE THE WINDOW AND INSTALL THE CASE (cont)

- D. Assemble the V-support and Sill Angle bracket with Type F nut and bolt

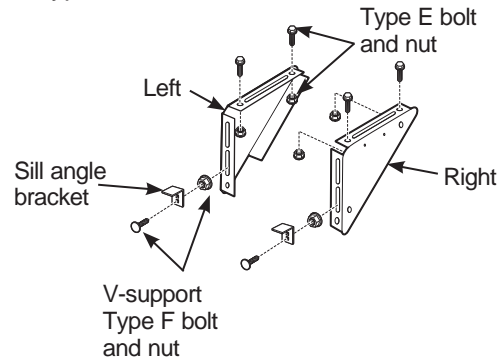

- E. Position the left V-support under the left side panel of the wall case and against the outside wall. Adjust the Sill Angle Bracket to rest on the sill. Attach the V-support to the wall case using 2 Type E bolts. Re-adjust the Sill Angle Bracket if necessary.

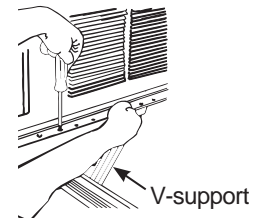

- F. Repeat with Right V-Support.

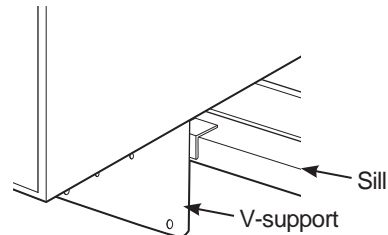

- G. Extend the left and right accordion panels to the vertical window sashes. Drill pilot holes and attach the top corners with 2 type C screws.

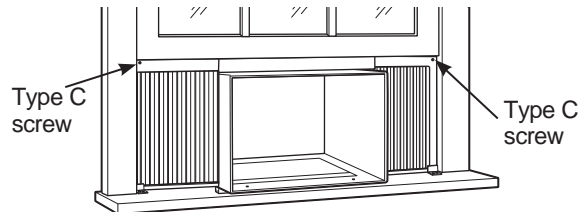

# Installation Instructions

## 6. SECURE THE CASE IN THE WINDOW AND INSTALL THE FOAM TOP WINDOW GASKET

**⚠ CAUTION** To prevent broken glass or damage to windows, on vinyl or other similarly constructed windows, attach the window locking bracket to the window side jamb.

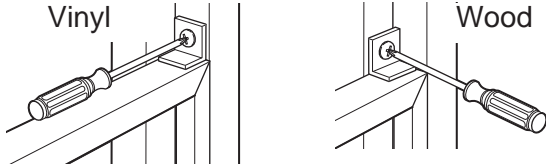

- A. Attach the window locking bracket with one Type C screw.
- B. Cut the foam top window gasket to the window width.



- C. Stuff the foam between the glass and the window to prevent air and insects from getting into the room.

**NOTE:** If the gasket supplied does not fit your window, obtain appropriate material locally to provide a proper installation seal.

## 7. INSTALL THE AIR CONDITIONER IN THE CASE

- A. Slide the air conditioner into the case by the base pan. Do not push on the controls, styrofoam air discharge housing or the finned coils. Make sure the air conditioner is firmly seated.

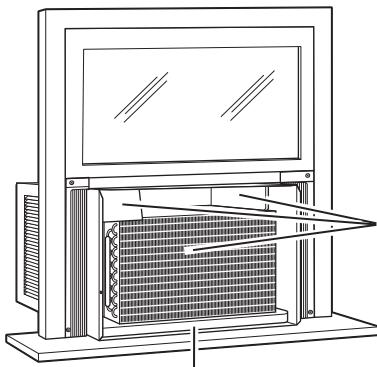

Do not press on these areas—  
damage to the unit  
may result

Base Pan

## 7. INSTALL THE AIR CONDITIONER IN THE CASE (CONT)

- B. Replace the 2 screws removed earlier, one on each side of the case.

**IMPORTANT: THE GROUND SCREWS MUST BE REINSTALLED TO ENSURE PROPER GROUND.**

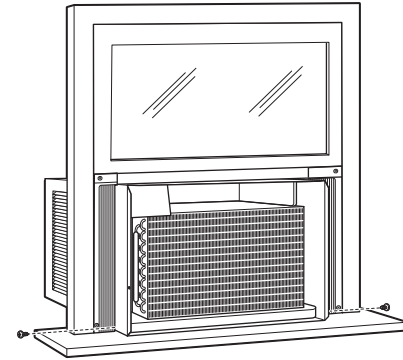

- C. Attach the front grille to the case by inserting the tabs on the grille into the slots on the front top of the case. Push the grille in.

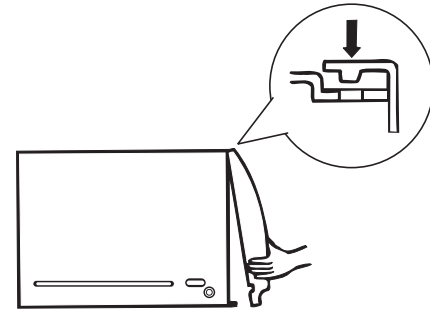

- D. Replace the screws.

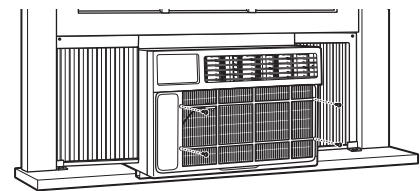

- E. Install the filter and the front grille.

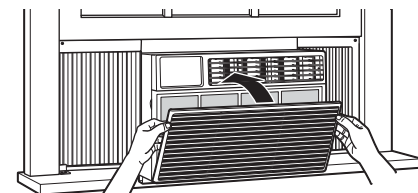

- F. Plug in the air conditioner.

# Through-the-Wall Installation Instructions – Optional

The case may be installed through-the-wall in both existing and new construction.

Read completely, then follow step-by-step.

**NOTE:** Obtain all materials locally for mounting the air conditioner through-the-wall.

## 1. IMPORTANT

- Through-the-wall installation is not appropriate if any of the side or top louvers in the case will be obstructed by the wall.
  - All side and top louvers in the case must project on the outdoor side of the wall.
  - The room side of the case must project into the room far enough to maximize the balance of the unit.
  - The case must be installed level from side-to-side and with a slight tilt from front to rear. Use a level; no more than a 1/2 bubble will be the correct case slant to the outside.
  - Lintel angle is required to support bricks or blocks above opening.
  - Flashing is required and should extend the length of the opening to ensure no inside cavity leakage occurs.
- A.** Remove the air conditioner from the case. For specific instruction, refer to the Window Installation Instructions.
- B.** Make certain that a wall receptacle is available close to the hole location or make arrangements to install a receptacle.

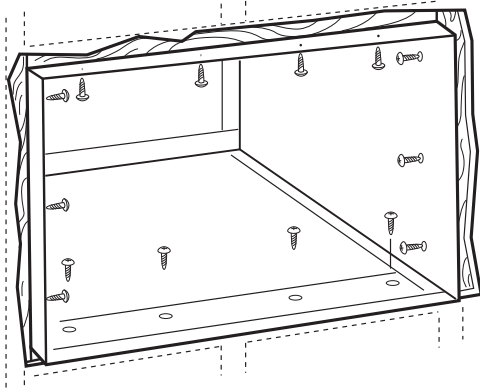

- C.** Place the case in the wall opening and place wood support strips between the case bottom and the flashing on both sides of the bottom rail. They should be the same height as the bottom rail and the same length as the wall opening.

## 1. IMPORTANT (cont)

- D.** Secure with 14 wood screws anchored at least an inch into the wall support structure.

**NOTE:** Drill pilot holes, if necessary, for proper installation. If the frame is oversized, use shims to prevent case distortion.

## 2. FINISH THE WALL OPENING

- A.** Caulk all four sides on the outdoor side of the case to prevent moisture from getting through to the interior wall. Use of flashing (drip rail) will further prevent water from dripping inside the wall and down the outside of the building.
- B.** Place the air conditioner into the case. For specific instruction, refer to the Window Installation Instructions.

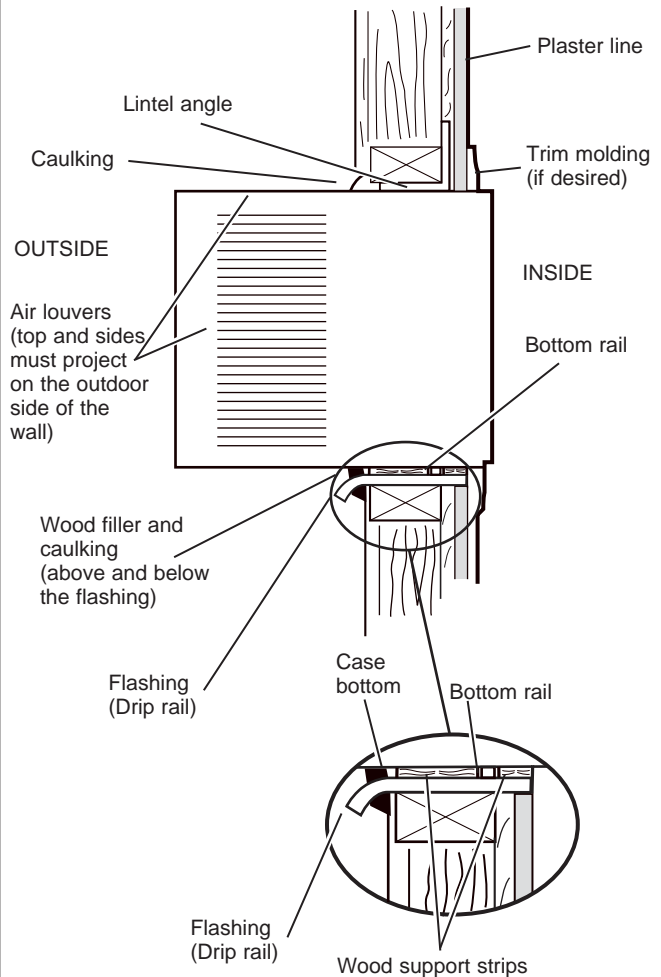

# Troubleshooting Tips...Before you call for service

Save time and money! Review the charts on the following pages first and you may not need to call for service.

Problem	Possible Cause	What To Do
Air conditioner does not start.	The unit is unplugged.	Make sure the air conditioner plug is pushed completely into the outlet.
	The fuse is blown/circuit breaker is tripped.	Check the house fuse/circuit breaker box and replace the fuse or reset the breaker.
	Power Failure.	The unit will automatically restart in the setting last used after the power is restored.
		There is a protective time delay (approximately 3 minutes) to prevent tripping of the compressor overload. For this reason, the unit may not start normal cooling for 3 minutes after it is turned back on.
	The current interrupter device is tripped.	Press RESET button located on the power cord plug. If the RESET button will not stay engaged, discontinue use of the air conditioner and contact a qualified service technician.
Air conditioner does not cool as it should.	Indoor airflow is restricted.	Make sure there are not curtains, blinds or furniture blocking the front of the air conditioner.
	The temp control may not be set properly.	Turn the temperature control to a higher number.
	The air filter is dirty.	Clean the filter at least every 30 days. See <b>Care and Cleaning</b> section.
	The room may have been hot.	When the air conditioner is first turned on, you need to allow time for the room to cool down.
	Cold air is escaping.	Check for open furnace registers and cold air returns.
	Cooling coils have iced up.	See "Air conditioner freezing up" below.
Air conditioner freezing up	Ice blocks the air flow and stops the air conditioner from cooling the room.	Set the mode control to High Fan or High Cool with the temperature setting as high as it can be set.
The remote control is not working	The batteries are inserted incorrectly	Check the position of the batteries. They should be inserted in with opposite (+) and (-) direction.
	The batteries may be dead	Replace the batteries
Water drips outside	Hot, humid weather.	This is normal.
Water drips inside	The air conditioner is not tilted to the outside.	For proper disposal, make sure the air conditioner slants slightly from the case front to the rear.
Water collects in base pan	Moisture removed from air and drain into base pan.	This is normal for a short period in areas with little humidity; normal for a longer period in very humid areas.

# Normal Operating Sounds

- You may hear a pinging noise caused by water being picked up and thrown against the condenser on rainy days or when the humidity is high. This design feature helps remove moisture and improve efficiency.
- You may hear the thermostat click when the compressor cycles on and off.
- Water will collect in the base pan during high humidity or on rainy days. The water may overflow and drip from the outdoor side of the unit.
- The fan may run even when the compressor does not.
- Water droplets being thrown against the outside coils can make a pinging noise. This helps cool the condenser. You can reduce this noise by removing the subbase water plug.

Removing this plug will lower the Energy Efficiency of your unit.

**NOTE:** Do not drill hole in the base pan.

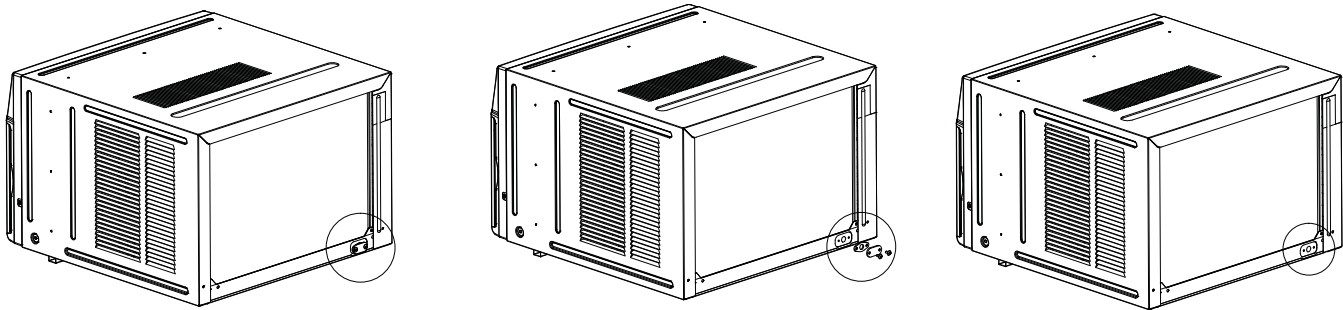

# Notes

---



# GE Appliances Air Conditioner - One-Year Limited Warranty

**WARRANTY**

All warranty service provided by our Factory Service Centers, or an authorized Customer Care® technician. To schedule service, visit us on-line at **GEAppliances.com**, or call GE Appliances at 800.GE.CARES (800.432.2737). Have serial number and model number available when calling for service.

For The Period Of:	GE Appliances Will Replace:
<b>One Year</b> From the date of the original purchase	<b>Any part</b> of the air conditioner which fails due to a defect in materials or workmanship. During this <b>limited one-year warranty</b> , GE Appliances will also provide, <b>free of charge</b> , all labor and related service to replace the defective part.

## What GE Appliances Will Not Cover:

- Service trips to your home to teach you how to use the product.
- Improper installation, delivery or maintenance. If you have an installation problem, or if the air conditioner is of improper cooling capacity for the intended use, contact your dealer or installer. You are responsible for providing adequate electrical connecting facilities.
- Failure of the product resulting from modifications to the product or due to unreasonable use including failure to provide reasonable and necessary maintenance.
- In commercial locations, labor necessary to move the unit to a location where it is accessible for service by an individual technician.
- Replacement of house fuses or resetting of circuit breakers.
- Failure due to corrosion on models not corrosion-protected.
- Damage to the product caused by improper power supply voltage, accident, fire, floods or acts of God.
- Incidental or consequential damage caused by possible defects with this air conditioner.
- Damage caused after delivery.

**EXCLUSION OF IMPLIED WARRANTIES—Your sole and exclusive remedy is product repair as provided in this Limited Warranty. Any implied warranties, including the implied warranties of merchantability or fitness for a particular purpose, are limited to one year or the shortest period allowed by law.**

This warranty is extended to the original purchaser and any succeeding owner for products purchased for home use within the USA. If the product is located in an area where service by a GE Appliances Authorized Servicer is not available, you may be responsible for a trip charge or you may be required to bring the product to an Authorized GE Appliances Service location for service. In Alaska, the warranty excludes the cost of shipping or service calls to your home.

Some states do not allow the exclusion or limitation of incidental or consequential damages. This warranty gives you specific legal rights, and you may also have other rights which vary from state to state. To know what your legal rights are, consult your local or state consumer affairs office or your state's Attorney General.

**Warrantor: GE Appliances, a Haier company**

Staple your receipt here. Proof of the original purchase date is needed to obtain service under the warranty.

# Consumer Support

---

## GE Appliances Website

Have a question or need assistance with your appliance? Try the GE Appliances Website 24 hours a day, any day of the year! You can also shop for more great GE Appliances products and take advantage of all our on-line support services designed for your convenience. In the US: [GEAppliances.com](http://GEAppliances.com)

---

## Register Your Appliance

Register your new appliance on-line at your convenience! Timely product registration will allow for enhanced communication and prompt service under the terms of your warranty, should the need arise. You may also mail in the pre-printed registration card included in the packing material. In the US: [GEAppliances.com/register](http://GEAppliances.com/register)

---

## Schedule Service

Expert GE Appliances repair service is only one step away from your door. Get on-line and schedule your service at your convenience any day of the year. In the US: [GEAppliances.com/ge/service-and-support/service.htm](http://GEAppliances.com/ge/service-and-support/service.htm) or call 800.432.2737 during normal business hours.

---

## Extended Warranties

Purchase a GE Appliances extended warranty and learn about special discounts that are available while your warranty is still in effect. You can purchase it on-line anytime. GE Appliances Services will still be there after your warranty expires. In the US: [GEAppliances.com/ge/service-and-support/shop-for-extended-service-plans.htm](http://GEAppliances.com/ge/service-and-support/shop-for-extended-service-plans.htm) or call 800.626.2224 during normal business hours.

---

## Remote Connectivity

For assistance with wireless network connectivity (for models with remote enable), visit our website at [GEAppliances.com/ge/connected-appliances/](http://GEAppliances.com/ge/connected-appliances/) or call 800.220.6899 in the US.

---

## Parts and Accessories

Individuals qualified to service their own appliances can have parts or accessories sent directly to their homes (VISA, MasterCard and Discover cards are accepted). Order on-line today 24 hours every day. In the US: [GEApplianceparts.com](http://GEApplianceparts.com) or by phone at 877.959.8688 during normal business hours.

**Instructions contained in this manual cover procedures to be performed by any user. Other servicing generally should be referred to qualified service personnel. Caution must be exercised, since improper servicing may cause unsafe operation.**

---

## Contact Us

If you are not satisfied with the service you receive from GE Appliances, contact us on our Website with all the details including your phone number, or write to:

In the US: General Manager, Customer Relations | GE Appliances, Appliance Park | Louisville, KY 40225  
[GEAppliances.com/ge/service-and-support/contact.htm](http://GEAppliances.com/ge/service-and-support/contact.htm)