



LEARN MORE

In an effort to conserve natural resources, this refrigerator includes a condensed User Guide. A complete User Instructions manual for your model can be downloaded at www.kitchenaid.com/customer-service/manuals. For future reference, please make a note of your product model and serial numbers. These can be found on the inside wall of the refrigerator compartment. Model Number _____ Serial Number _____

For assistance or service, call **1-800-422-1230** in the U.S.A. or **1-800-807-6777** in Canada.

Register your refrigerator at www.kitchenaid.com. In Canada, register at www.kitchenaid.ca.

Para una versión de estas instrucciones en español, visite www.kitchenaid.com.

Your safety and the safety of others are very important.

We have provided many important safety messages in this manual and on your appliance. Always read and obey all safety messages.



This is the safety alert symbol.

This symbol alerts you to potential hazards that can kill or hurt you and others.

All safety messages will follow the safety alert symbol and either the word “DANGER” or “WARNING.”

These words mean:

⚠ DANGER

You can be killed or seriously injured if you don't immediately follow instructions.

⚠ WARNING

You can be killed or seriously injured if you don't follow instructions.

All safety messages will tell you what the potential hazard is, tell you how to reduce the chance of injury, and tell you what can happen if the instructions are not followed.

IMPORTANT SAFETY INSTRUCTIONS

WARNING: To reduce the risk of fire, electric shock, or injury when using your refrigerator, follow these basic precautions:

- Plug into a grounded 3 prong outlet.
- Do not remove ground prong.
- Do not use an adapter.
- Do not use an extension cord.
- Disconnect power before servicing.
- Replace all parts and panels before operating.
- Remove doors from your old refrigerator.
- Use nonflammable cleaner.
- Keep flammable materials and vapors, such as gasoline, away from refrigerator.
- Use two or more people to move and install refrigerator.
- Disconnect power before installing ice maker (on ice maker kit ready models only).
- Use a sturdy glass when dispensing ice (on some models).
- Do not hit the refrigerator glass doors (on some models).

SAVE THESE INSTRUCTIONS

State of California Proposition 65 Warnings:

WARNING: This product contains one or more chemicals known to the State of California to cause cancer.

WARNING: This product contains one or more chemicals known to the State of California to cause birth defects or other reproductive harm.

PROPER DISPOSAL OF YOUR OLD REFRIGERATOR

WARNING

Suffocation Hazard

Remove doors from your old refrigerator.

Failure to do so can result in death or brain damage.

IMPORTANT: Child entrapment and suffocation are not problems of the past. Junked or abandoned refrigerators are still dangerous, even if they will sit for “just a few days.” If you are getting rid of your old refrigerator, please follow these instructions to help prevent accidents.

Before You Throw Away Your Old Refrigerator or Freezer:

- Take off the doors.
- Leave the shelves in place so that children may not easily climb inside.

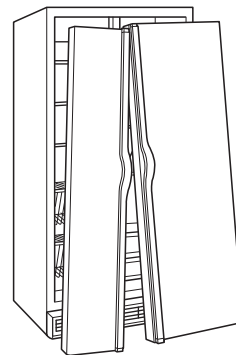

Important information to know about disposal of refrigerants:

Dispose of refrigerator in accordance with Federal and Local regulations. Refrigerants must be evacuated by a licensed, EPA certified refrigerant technician in accordance with established procedures.

OPERATING YOUR REFRIGERATOR

Using the Controls

The refrigerator and freezer controls are located on the dispenser panel.

IMPORTANT: The display screen on the dispenser control panel will turn off automatically and enter “sleep” mode when the control buttons and dispenser pads have not been used for 2 minutes or more. While in “sleep” mode, the first press of a control button will only reactivate the display screen, without changing any settings.

- Touch any control button on the dispenser panel to activate the display screen. The home screen will appear as shown.

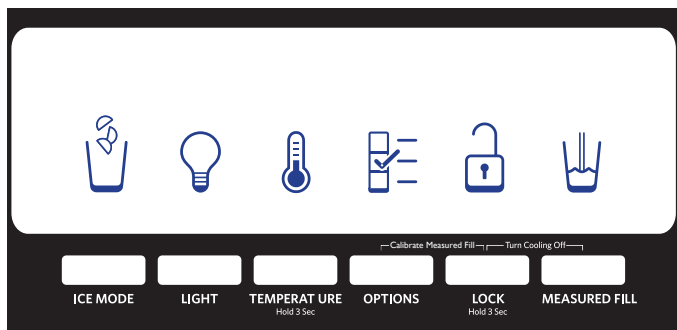

Adjusting the Controls

For your convenience, your refrigerator and freezer controls are preset at the factory. When you first install your refrigerator, make sure that the controls are still set to the “mid-settings.” The factory recommended set points are 37°F (3°C) for the refrigerator and 0°F (-18°C) for the freezer.

IMPORTANT:

- Wait 24 hours before you put food into the refrigerator. If you add food before the refrigerator has cooled completely, your food may spoil.
NOTE: Adjusting the set points to a colder than recommended setting will not cool the compartments any faster.
- If the temperature is too warm or too cold in the refrigerator or freezer, first check the air vents to be sure they are not blocked before adjusting the controls.
- The preset settings should be correct for normal household usage. The controls are set correctly when milk or juice is as cold as you like and when ice cream is firm.

- Wait at least 24 hours between adjustments. Recheck the temperatures before other adjustments are made.

To view and adjust the set points, press and hold the TEMPERATURE button for 3 seconds. When adjust mode is activated, adjusting information will appear on the display screen.

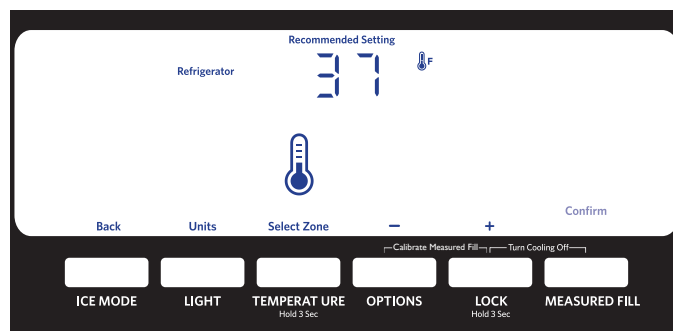

NOTE: To view Celsius temperatures, press the LIGHT button when adjust mode is activated. To return the display setting to Fahrenheit, press LIGHT again.

- When adjust mode is activated, the display screen shows the refrigerator set point and “REFRIGERATOR” appears.
- Press LOCK to raise the set point, or press OPTIONS to lower the set point.
- When you have finished viewing (and adjusting if desired) the refrigerator set point, press TEMPERATURE to change the display to show the freezer set point. When the zone has been changed, “FREEZER” appears on the display screen.
- Press LOCK to raise the set point, or press OPTIONS to lower the set point.
- When you have finished viewing (and adjusting if desired) both the refrigerator and freezer set points, press MEASURED FILL to save the settings.

NOTE: To exit without saving changes, press ICE MODE at any time while in adjust mode, or allow about 60 seconds of inactivity and adjust mode will turn off automatically.

When adjusting temperature set points, use the following chart as a guide.

CONDITION:	TEMPERATURE ADJUSTMENT:
REFRIGERATOR too cold	REFRIGERATOR Setting 1° higher
REFRIGERATOR too warm	REFRIGERATOR Setting 1° lower
FREEZER too cold	FREEZER Setting 1° higher
FREEZER too warm / Too little ice	FREEZER Setting 1° lower

The set point range for the refrigerator is 33°F to 42°F (0°C to 6°C). The set point range for the freezer is -9°F to 5°F (-23°C to -15°C).

Cooling On/Off

Your refrigerator and freezer will not cool when cooling is turned off.

- To turn cooling off, press and hold the LOCK and MEASURED FILL buttons at the same time for 3 seconds.

IMPORTANT: To avoid unintentionally locking the dispenser or changing other settings, be sure to press both buttons at exactly the same time.

When cooling is off, “REFRIGERATION COOLING IS OFF” will appear on the display screen.

- Press and hold LOCK and MEASURED FILL for 3 seconds again to turn cooling back on.

Additional Features

Max Cool and Max Ice

The Max Cool feature assists with periods of heavy ice usage, full grocery loads, or temporarily warm room temperatures.

The Max Ice feature assists with temporary periods of heavy ice use by increasing ice production over a 24-hour period.

- To turn on the Max Cool feature, press the OPTIONS button to enter Options mode, then press OPTIONS again to activate the feature. The Max Cool icon will appear on the dispenser display. 

The Max Cool feature will remain on for 24 hours unless manually turned off. To manually turn it off, press the OPTIONS button to enter Options mode (unless you are already in Options mode), then press OPTIONS again. When the feature has been turned off, the Max Cool icon will disappear on the dispenser display.

- To turn on the Max Ice feature, press the OPTIONS button to enter Options mode, then press the TEMPERATURE button to activate the feature. The Max Ice icon will appear on the dispenser display. 

The Max Ice feature will remain on for 24 hours unless manually turned off. To manually turn it off, press the OPTIONS button to enter Options mode (unless you are already in Options mode), then press TEMPERATURE. When the feature has been turned off, the Max Ice icon will disappear on the dispenser display.

When Max Cool and/or Max Ice are active, the temperature display will not change. After 24 hours, the refrigerator returns to the previous temperature set points.

NOTE: If increased ice production is desired at all times, change the freezer control to a lower setting. Setting the freezer to a colder temperature may make some foods, such as ice cream, harder.

Sabbath Mode

Sabbath Mode is designed for those whose religious observances require turning off the lights and dispensers.

In Sabbath Mode, the temperature set points remain unchanged, but the interior and dispenser lights turn off, all sounds and alarms are disabled, the dispenser display screen backlight turns off, and the dispenser pads are disabled.

- To turn on Sabbath Mode, press and hold LIGHT and OPTIONS at the same time for 3 seconds. When the feature turns on, “Sabbath Mode” will appear on the dispenser display.
- To turn off Sabbath Mode, press and hold LIGHT and OPTIONS at the same time for 3 seconds again.

Power Outage Indicator

The power outage indicator lets you know if the power supply to the refrigerator has been cut off and the freezer temperature has risen to 18°F (-8°C) or higher.

When power has been restored, “PO” repeatedly flashes on the display screen and the red Power Outage icon appears. 

When the indicator is on, all other control and dispenser functions are disabled until you confirm that you are aware of the power outage.

- To enable other functions, press MEASURED FILL to reset the display screen to its normal status.

Door Ajar Alarm

The Door Ajar Alarm feature sounds an alarm when the refrigerator or freezer door is open for 5 minutes and the product cooling is turned on. The alarm will repeat every 2 minutes. Close both doors to turn it off. The feature then resets and will reactivate when either door is left open again for 5 minutes.

NOTE: To mute the audible alarm while keeping the doors open, such as while cleaning the inside of the refrigerator, press any button on the control panel. The alarm sound will be temporarily turned off, but the Door Ajar icon will still be displayed on the dispenser control panel. 

Disabling Sounds

- To turn off all control and dispenser sounds, press and hold ICE and MEASURED FILL at the same time for 3 seconds.
- To turn all sounds back on, press and hold ICE and MEASURED FILL at the same time for 3 seconds again.

Dual Evaporator (on some models)

Some models come equipped with a dual sequential evaporation system, which includes two separate evaporators for the refrigerator and freezer compartments.

Dual evaporation results in higher humidity, which helps keep foods in the refrigerator from spoiling as quickly and improves food quality and freshness in the freezer due to decreased freezer burn. In addition, the dual evaporation system helps keep food smells in the refrigerator from transferring to ice in the freezer.

NOTE: The dual evaporation system is always activated when your refrigerator is operating. You do not need to press any buttons to turn it on.

Convertible Drawer Temperature Control

The control can be adjusted to properly chill meats or vegetables. The air inside the pan is cooled to avoid “spot” freezing and can be set to keep meats at the National Livestock and Meat Board recommended storage temperatures of 28° to 32°F (-2° to 0°C).

To store meat:

Set the control to one of the three MEAT settings to store meat at its optimal storage temperature.

To store vegetables:

Set the control to VEG to store vegetables at their optimal storage temperatures.

NOTE: If food starts to freeze, move the control to the right (less cold), toward the VEG setting. Remember to wait 24 hours between adjustments.

Crisper Humidity Control

You can control the amount of humidity in the moisture-sealed crisper. Adjust the control to any setting between LOW and HIGH.

LOW (open) for best storage of fruits and vegetables with skins.
HIGH (closed) for best storage of fresh, leafy vegetables.

ICE AND WATER

Water and Ice Dispensers

NOTES:

- The dispensing system will not operate when freezer door is open.
- Allow 24 hours for the refrigerator to cool down and chill water.
- Allow 24 hours to produce the first batch of ice. Discard the first three batches of ice produced. Wait 72 hours for full ice production.

Flush the Water System

Air in the water dispensing system can cause the water dispenser to drip. After connecting the refrigerator to a water source or replacing the water filter, flush the water system. Flushing the water dispensing system forces air from the water line and filter, and prepares the water filter for use.

NOTE: As air is cleared from the system, water may spurt out of the dispenser.

1. Using a sturdy container, depress and hold the water dispenser pad for 5 seconds, then release it for 5 seconds.
2. Repeat Step 1 until water begins to flow.
3. Once water begins to flow, continue depressing and releasing the dispenser pad (5 seconds on, 5 seconds off) until a total of 3 gal. (12 L) has been dispensed.

Additional flushing may be required in some households.

Calibrate Measured Fill

Household water pressure may affect the accuracy of the Measured Fill feature. For optimum performance of your water dispenser, you must first calibrate Measured Fill.

IMPORTANT: Flush the water system before calibrating Measured Fill.

1. Place a sturdy measuring cup (1 cup [237 mL] size) on the dispenser tray, centered in front of the water dispenser pad.

NOTE: Depending on your model, a measuring cup may be provided.

2. Press and hold the **OPTIONS** and **LOCK** buttons at the same time for 3 seconds. The words “Back” and “1 Cup” will appear on the display screen. Also, the Calibrate Measured Fill icon will illuminate and remain lit while the Measured Fill feature is being calibrated.



NOTE: You may press the **ICE MODE** button under the word “Back” at any time to exit calibration mode. The Calibrate Measured Fill icon will turn off.

3. Using your hand (not the measuring cup), press and release the water dispenser pad in order to dispense water to the 1 cup fill line.

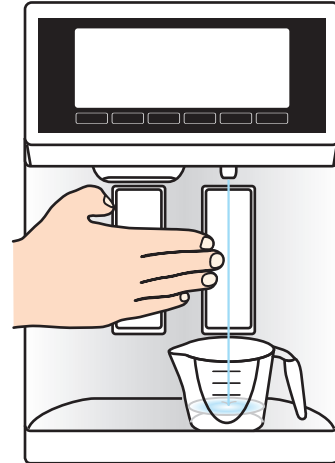

NOTE: If overfilling or spilling occurs, discard the water and press “Back” to restart the calibration process.

4. When 1 cup of water has been correctly dispensed into the measuring cup, press the **MEASURED FILL** button under the word “Confirm” to confirm the calibration.

When Measured Fill calibration has been confirmed, the display will return to the home screen.

The Water Dispenser

IMPORTANT:

- Dispense at least 1 qt (1 L) of water every week to maintain a fresh supply.
- If the flow of water from the dispenser decreases, it could be caused by low water pressure.
 - With the water filter removed, dispense 1 cup (237 mL) of water. If 1 cup of water is dispensed in 8 seconds or less, the water pressure to the refrigerator meets the minimum requirement.
 - If it takes longer than 8 seconds to dispense 1 cup of water, the water pressure to the refrigerator is lower than recommended. See “Water Supply Requirements” (in the User Instructions or the Installation Instructions and Owner’s Manual) or “Problem Solver” for suggestions.

To Dispense Water (Standard):

1. Press a sturdy glass against the water dispenser pad. Hold the glass close to the water dispenser spout to ensure that the water dispenses into the glass.

NOTE: While dispensing water and for 3 seconds after dispensing has stopped, the digital display will show how much water has been dispensed.
2. Remove the glass to stop dispensing.

To Dispense Water (Measured Fill):

Measured Fill allows you to dispense a specified amount of water with the touch of a few buttons.

NOTE: The amount of water you select will be dispensed. Be sure that the container is empty and can hold the entire volume. If ice is in the container, you may need to adjust your selection.

IMPORTANT: Low water pressure may affect the accuracy of this feature.

1. Press MEASURED FILL to turn the feature on. When the feature is on, the Measured Fill screen appears on the display.

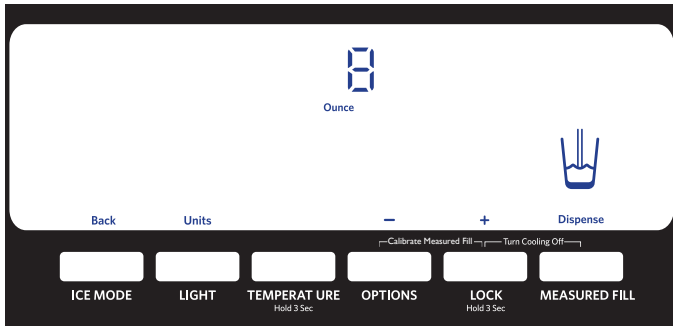

Press ICE MODE to manually turn off the Measured Fill feature.

NOTE: The dispenser will automatically turn off Measured Fill after 1 minute of inactivity. When Measured Fill is turned off, any changes you have made will be lost and all defaults will be restored.

2. You can dispense water by the ounce, cup, or liter. The default unit is ounces. To switch to cups or liters, press the LIGHT button.

Default, minimum, and maximum volumes are listed below.

Units	Default	Minimum	Maximum
Ounces	8	1	128
Cups	1	1/4	16
Liters	0.25	0.05	4.00

3. Press the LOCK and OPTIONS buttons to adjust the volume as desired. The LOCK button increases the volume, and the OPTIONS button lowers the volume.

NOTES:

- When increasing or decreasing the volume, the control may stop responding if an adjustment button is held for approximately 10 seconds or longer. Release the button for approximately 2 seconds, then continue making adjustments.
- Most coffee cups (commonly 4 to 6 oz [118 to 177 mL] per cup) are not the same size as a measuring cup (8 oz [237 mL]). You may need to adjust the volume to avoid unintentionally overfilling coffee cups.

4. To dispense water, press a sturdy glass against the water dispenser pad OR place the glass below the water dispenser and press the MEASURED FILL button. Hold the glass close to the water dispenser spout to ensure that the water dispenses into the glass.

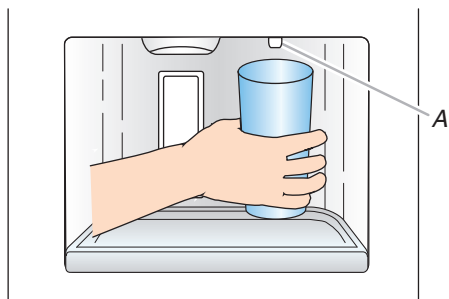

A. Water dispenser spout

NOTE: While dispensing water, the digital display will count down how much water remains to be dispensed, according to the volume you selected. The flow of water will automatically stop once the desired volume has been dispensed.

5. To stop dispensing before the selected volume has been dispensed, remove the glass from the dispenser pad OR press the MEASURED FILL button a second time.

NOTE: If you stop dispensing before the desired volume has been dispensed, the digital display will continue to show how much water remains to be dispensed. The display will turn off after 1 minute of inactivity.

To select a new volume or start dispensing the same volume again, you must first finish dispensing the selected volume, or turn off the Measured Fill feature (either by waiting 1 minute so it will automatically turn off or by pressing ICE MODE to manually turn it off) and then turn it back on.

The Ice Dispenser

Ice dispenses from the ice maker storage bin in the freezer when the dispenser pad is pressed. To turn off the ice maker, see "Ice Maker and Storage Bin."

Your ice maker can produce both crushed and cubed ice. Before dispensing ice, select which type of ice you prefer by pressing the ICE MODE button.

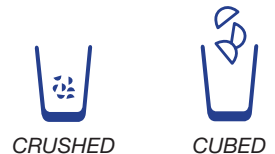

The display screen indicates which type of ice is selected.

For crushed ice, cubes are crushed before being dispensed. This may cause a slight delay when dispensing crushed ice. Noise from the ice crusher is normal, and pieces of ice may vary in size. When changing from crushed to cubed, a few ounces of crushed ice will be dispensed along with the first cubes.

To Dispense Ice:

1. Make sure the desired type of ice is selected. To switch between cubed and crushed, press ICE MODE.

⚠ WARNING

Cut Hazard

Use a sturdy glass when dispensing ice.

Failure to do so can result in cuts.

2. Press a sturdy glass against the ice dispenser pad. Hold the glass close to the ice guide to ensure that the ice dispenses into the glass.

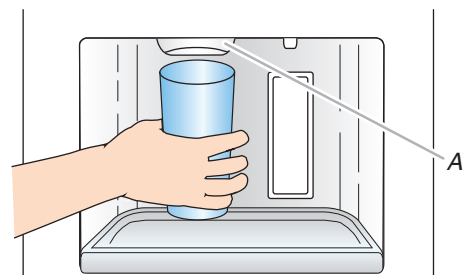

A. Ice guide

IMPORTANT: You do not need to apply a lot of pressure to the pad in order to activate the ice dispenser. Pressing hard will not make the ice dispense faster or in greater quantities.

3. Remove the glass to stop dispensing.

NOTE: Ice may continue to dispense for several seconds after removing the glass from the pad. The dispenser may continue to make noise for a few seconds after dispensing.

The Dispenser Light

When you use the dispenser, the light will automatically turn on. If you want the light to be on continuously, you may choose either ON or DIM. The display screen indicates which mode is selected.



ON: Press LIGHT to turn the dispenser light on.

DIM: Press LIGHT a second time to select DIM mode. The dispenser light will remain on, but at a lower intensity.

OFF: Press LIGHT a third time to turn the dispenser light off.

If the dispenser lights do not appear to be working as described in “Water and Ice Dispensers” (in the User Instructions, User Guide, or Use & Care Guide) or if the interior lights do not illuminate when either door is opened, call for assistance or service. See either the front cover or the Warranty for contact information.

The Dispenser Lock

The dispenser can be turned off for easy cleaning or to avoid unintentional dispensing by small children and pets.

NOTE: The lock feature does not shut off power to the refrigerator, to the ice maker, or to the dispenser light. It simply deactivates the controls and dispenser pads. To turn off the ice maker, see “Ice Maker and Storage Bin.”

- Press and hold LOCK for 3 seconds to lock the dispenser.
- Press and hold LOCK a second time to unlock the dispenser.



The display screen indicates when the dispenser is locked.

Ice Maker and Storage Bin

- Allow 24 hours to produce the first batch of ice. Discard the first three batches of ice produced.
- The quality of your ice will be only as good as the quality of the water supplied to your ice maker. Avoid connecting the ice maker to a softened water supply. Water softener chemicals (such as salt) can damage parts of the ice maker and lead to poor quality ice. If a softened water supply cannot be avoided, make sure the water softener is operating properly and is well maintained.
- Do not use anything sharp to break up the ice in the storage bin. This can cause damage to the ice container and the dispenser mechanism.
- Do not store anything on top of or in the ice maker or storage bin.

Turning the Ice Maker On/Off

The On/Off switch, located on the left wall of the freezer door, can only be accessed when the ice storage bin has been removed. See the following section for bin removal instructions.

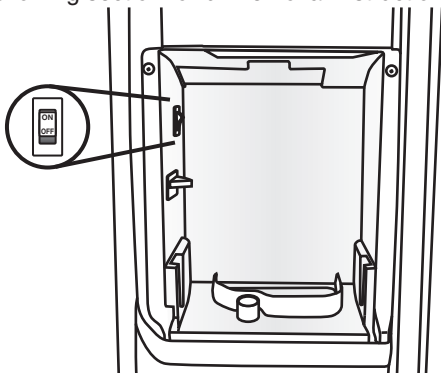

- To turn on the ice maker, flip the switch to the ON (up) position.
- To manually turn off the ice maker, flip the switch to the OFF (down) position.

NOTE: The ice maker has an automatic shutoff to keep the storage bin from overflowing during normal operation. As ice is made, the ice cubes will fill the ice storage bin, and the ice cubes will raise the shutoff arm to the OFF (arm up) position. When the storage bin is at full capacity, the ice maker will automatically stop ice production, but the ice maker On/Off switch will remain in the ON (up) position.

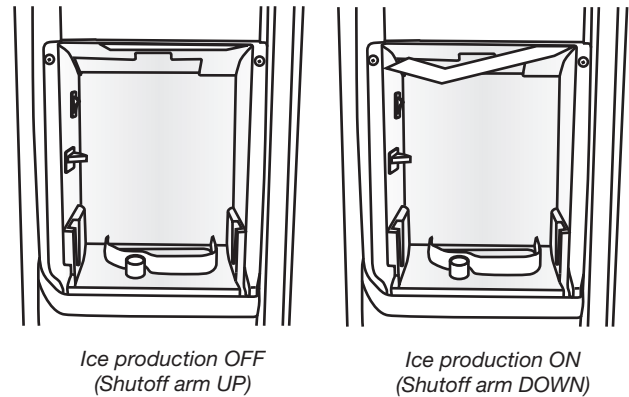

Removing and Replacing the Ice Storage Bin:

1. Press down the release lever and tilt the bucket outward. Use both hands to hold the base of the storage bin, then lift it up and out.

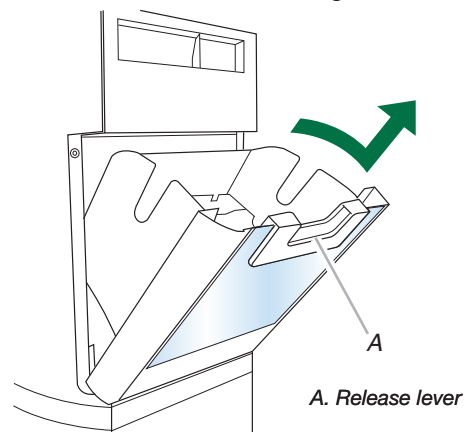

NOTE: It is not necessary to flip the ice maker On/Off switch to the OFF (down) position when removing the storage bin. The storage bin sensor, located on the right wall of the freezer door, stops the ice maker from producing ice if the door is open or the storage bin is removed.

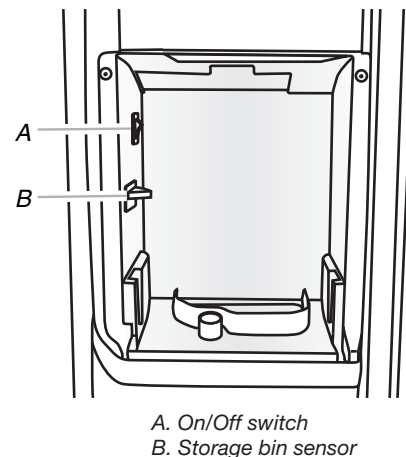

2. Replace the bin by sliding it onto the door, then tilting it back into an upright position. The release lever will click when the bin is securely in place.

Water Filtration System

Do not use with water that is microbiologically unsafe or of unknown quality without adequate disinfection before or after the system. Systems certified for cyst reduction may be used on disinfected waters that may contain filterable cysts.

Water Filter Status Light

The water filter status light will help you know when to change your water filter.

- When the dispenser control panel's water filter status display changes to "ORDER," this tells you that it is almost time to change the water filter cartridge.
- Replace the water filter cartridge when the water filter status display changes to "REPLACE."

NOTE: If water flow to your water dispenser or ice maker decreases noticeably, change the filter sooner. The filter should be replaced at least every 6 months, depending on your water quality and usage.

Resetting the Filter Status

- After changing the water filter, reset the status light. Press the **OPTIONS** button to enter Options mode, then press **LOCK** to initiate the reset, then press **MEASURED FILL** to confirm that you want to reset the status light.

When the system is reset, the "ORDER" and "REPLACE" icons will disappear from the display screen.

Changing the Water Filter

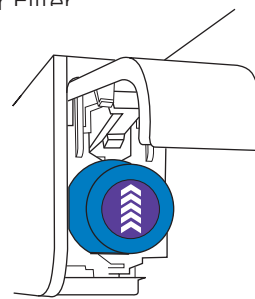

1. Locate the water filter in the top-right corner of the refrigerator compartment.
2. Lift open the filter cover door. The filter will be released and then be ejected as the door is opened.
3. When the door is completely open, pull the filter straight out.
NOTE: There may be some water in the filter. Some spilling may occur. Use a towel to wipe up any spills.
4. Take the new filter out of its packaging and remove the cap. Be sure the O-rings are still in place after the cap is removed.
5. With the arrow pointing up, align the new filter with the filter housing and slide it into place. The filter cover door will automatically begin to close as the new filter is inserted.
6. Close the filter cover door completely in order to snap the filter into place. You may need to press hard.
7. Flush the water system. See "Water and Ice Dispensers."

ACCESSORIES

The following accessories are available for your refrigerator.

To order an accessory: Contact us and ask for the part number listed, or contact your authorized dealer.

In the U.S.A., call **1-800-442-9991** or visit www.kitchenaid.com.

In Canada, call **1-800-807-6777** or visit www.whirlpoolparts.ca.

affresh® Stainless Steel Cleaner:

Order Part #W10355016

In Canada, order Part #W10355016B

affresh® Stainless Steel Wipes:

Order Part #W10355049

In Canada, order Part #W10355049B

affresh® Kitchen & Appliance Cleaner:

Order Part #W10355010

In Canada, order Part #W10355010B

Water Filter:

Order Part #W10295370A (P4RFBW)

Air Filter:

Order Part #W10311524

Produce Preserver:

Order Part #W10346771

PROBLEM SOLVER



For recommendations that may help you avoid a service call, scan the code at left with your mobile device, or visit <https://kitchenaid.custhelp.com>.

For a complete Problem Solver listing with more information, see the Installation Instructions and Owner's Manual provided with your refrigerator, or visit our website and download the User Instructions for your model.

KITCHENAID® REFRIGERATION LIMITED WARRANTY

ATTACH YOUR RECEIPT HERE. PROOF OF PURCHASE IS REQUIRED TO OBTAIN WARRANTY SERVICE.

Please have the following information available when you call the Customer eXperience Center:

- Name, address and telephone number
- Model number and serial number
- A clear, detailed description of the problem
- Proof of purchase including dealer or retailer name and address

IF YOU NEED SERVICE:

1. Before contacting us to arrange service, please determine whether your product requires repair. Some questions can be addressed without service. Please take a few minutes to review the Troubleshooting or Problem Solver section of the Use and Care Guide, scan the QR code on the right to access additional resources, or visit <http://kitchenaid.custhelp.com>.
2. All warranty service is provided exclusively by our authorized KitchenAid Service Providers. In the U.S. and Canada, direct all requests for warranty service to:

KitchenAid Customer eXperience Center

In the U.S.A., call 1-800-422-1230. In Canada, call 1-800-807-6777.

If outside the 50 United States or Canada, contact your authorized KitchenAid dealer to determine whether another warranty applies.



<http://kitchenaid.custhelp.com>

TEN YEAR LIMITED WARRANTY

WHAT IS COVERED

LIMITED WARRANTY

For one year from the date of purchase, when this major appliance is installed, operated and maintained according to instructions attached to or furnished with the product, KitchenAid brand of Whirlpool Corporation or Whirlpool Canada LP (hereafter "KitchenAid") will pay for Factory Specified Replacement Parts and repair labor to correct defects in materials or workmanship that existed when this major appliance was purchased, or at its sole discretion replace the product. In the event of product replacement, your appliance will be warranted for the remaining term of the original unit's warranty period.

SECOND THROUGH FIFTH YEAR LIMITED WARRANTY ON CAVITY LINER AND SEALED REFRIGERATION SYSTEM

In the second through fifth years from the date of purchase, when this major appliance is installed, operated and maintained according to the instructions attached to or furnished with the product, KitchenAid brand will pay for factory specified replacement parts and repair labor for the following components to correct non-cosmetic defects in materials and workmanship in this part that prevent function of the refrigerator and that existed when this major appliance was purchased:

- Refrigerator/freezer cavity liner if the part cracks due to defective materials or workmanship.
- Sealed Refrigeration system (includes compressor, evaporator, condenser, dryer and connecting tubing).

SIXTH THROUGH TENTH YEAR LIMITED WARRANTY (SEALED REFRIGERATION SYSTEM ONLY - LABOR NOT INCLUDED)

In the sixth through tenth year from the date of purchase, when this major appliance is installed, operated and maintained according to instructions attached to or furnished with the product, KitchenAid brand will pay for factory specified replacement parts for the following components to correct defects in materials or workmanship in the sealed refrigeration system (includes compressor, evaporator, condenser, dryer and connecting tubing) that existed when this major appliance was purchased.

YOUR SOLE AND EXCLUSIVE REMEDY UNDER THIS LIMITED WARRANTY SHALL BE PRODUCT REPAIR AS PROVIDED HEREIN. Service must be provided by a KitchenAid designated service company. This limited warranty is valid only in the United States or Canada and applies only when the major appliance is used in the country in which it was purchased. This limited warranty is effective from the date of original consumer purchase. Proof of original purchase date is required to obtain service under this limited warranty.

WHAT IS NOT COVERED

1. Commercial, non-residential or multiple-family use, or use inconsistent with published user, operator or installation instructions.
2. In-home Instruction on how to use your product
3. Service to correct improper product maintenance or installation, installation not in accordance with electrical or plumbing codes or correction of household electrical or plumbing (i.e. house wiring, fuses or water inlet hoses).
4. Consumable parts (i.e. light bulbs, batteries, air or water filters, preservation solutions, etc.).
5. Defects or damage caused by the use of non-genuine KitchenAid parts or accessories.
6. Damage from accident, misuse, abuse, fire, floods, acts of God or use with products not approved by KitchenAid.
7. Repairs to parts or systems to correct product damage or defects caused by unauthorized service, alteration or modification of the appliance.
8. Cosmetic damage including scratches, dents, chips, and other damage to appliance finishes unless such damage results from defects in materials and workmanship and is reported to KitchenAid within 30 days.
9. Discoloration, rust or oxidation of surfaces resulting from caustic or corrosive environments including but not limited to high salt concentrations, high moisture or humidity or exposure to chemicals.
10. Food or medicine loss due to product failure.
11. Pick-up or delivery. This product is intended for in-home repair.
12. Travel or transportation expenses for service in remote locations where an authorized KitchenAid servicer is not available.
13. Removal or reinstallation of inaccessible appliances or built-in fixtures (i.e. trim, decorative panels, flooring, cabinetry, islands, countertops, drywall, etc.) that interfere with servicing, removal or replacement of the product.
14. Service or parts for appliances with original model/serial numbers removed, altered or not easily determined.

The cost of repair or replacement under these excluded circumstances shall be borne by the customer.

DISCLAIMER OF IMPLIED WARRANTIES

IMPLIED WARRANTIES, INCLUDING ANY IMPLIED WARRANTY OF MERCHANTABILITY OR IMPLIED WARRANTY OF FITNESS FOR A PARTICULAR PURPOSE, ARE LIMITED TO ONE YEAR OR THE SHORTEST PERIOD ALLOWED BY LAW. Some states and provinces do not allow limitations on the duration of implied warranties of merchantability or fitness, so this limitation may not apply to you. This warranty gives you specific legal rights, and you also may have other rights that vary from state to state or province to province.

DISCLAIMER OF REPRESENTATIONS OUTSIDE OF WARRANTY

KitchenAid makes no representations about the quality, durability, or need for service or repair of this major appliance other than the representations contained in this warranty. If you want a longer or more comprehensive warranty than the limited warranty that comes with this major appliance, you should ask KitchenAid or your retailer about buying an extended warranty.

LIMITATION OF REMEDIES; EXCLUSION OF INCIDENTAL AND CONSEQUENTIAL DAMAGES

YOUR SOLE AND EXCLUSIVE REMEDY UNDER THIS LIMITED WARRANTY SHALL BE PRODUCT REPAIR AS PROVIDED HEREIN. KITCHENAID SHALL NOT BE LIABLE FOR INCIDENTAL OR CONSEQUENTIAL DAMAGES. Some states and provinces do not allow the exclusion or limitation of incidental or consequential damages, so these limitations and exclusions may not apply to you. This warranty gives you specific legal rights, and you also may have other rights that vary from state to state or province to province.

