



# PREMIER 41" 15-DRAWER MOBILE TOOL CHEST COMBO

Assembly Instructions

MODEL/MODÈLE/MODELO:  
GATC4115JG

## ENSEMBLE COFFRE ET ARMOIRE MOBILE HAUTE QUALITÉ DE 41" AVEC 15 TIROIRS

Instructions d'assemblage

## JUEGO DE GABINETE Y CAJA DE CALIDAD SUPERIOR MÓVIL DE 41" CON 15 CAJONES

Instrucciones de ensamblaje

### TABLE OF CONTENTS/TABLE DES MATIÈRES/ÍNDICE

MOBILE TOOL CHEST COMBO	SÉCURITÉ DE L'ENSEMBLE	SEGURIDAD DEL JUEGO DE
SAFETY..... 2	COFFRE ET ARMOIRE MOBILE..... 9	GABINETE Y CAJA..... 17
DIMENSIONS..... 3	DIMENSIONS..... 10	DIMENSIONES..... 18
TOOL CHEST COMBO USE	CONDITIONS D'UTILISATION DE	REQUISITOS DE USO DEL
REQUIREMENTS..... 4	L'ENSEMBLE COFFRE ET ARMOIRE ... 11	JUEGO DE GABINETE Y CAJA..... 19
ASSEMBLY INSTRUCTIONS..... 4	INSTRUCTIONS D'ASSEMBLAGE..... 11	INSTRUCCIONES DE ENSAMBLAJE.... 19
FINAL ASSEMBLY..... 6	ASSEMBLAGE FINAL..... 13	MONTAJE FINAL..... 21
POWER OUTLET WITH USB..... 7	UTILISATION, ENLEVER ET	TOMA DE CORRIENTE CON USB..... 22
MAGNETIC TOOL HOLDER..... 7	PRISE DE COURANT AVEC USB..... 14	PORTAHERRAMIENTAS
TOOL CHEST COMBO	PORTE-OUTIL MAGNÉTIQUE..... 14	MAGNÉTICO..... 22
MAINTENANCE..... 7	MAINTENANCE DE L'ENSEMBLE	MANTENIMIENTO DEL JUEGO DE
REGISTERING YOUR PRODUCT..... 7	COFFRE ET ARMOIRE..... 14	GABINETE Y CAJA..... 22
WARRANTY..... 8	ENREGISTREMENT DE VOTRE	CÓMO REGISTRAR EL PRODUCTO.... 22
	PRODUIT..... 14	GARANTÍA..... 23
	GARANTIE..... 15	

**W11381276B** In U.S.A. call: 1-866-342-4089 In Canada call: 1-800-807-6777  
 Aux É.U. téléphoner au: 1-866-342-4089 Au Canada téléphoner: 1-800-807-6777 www.gladiatorgarageworks.com  
 En EE.UU. llame al: 1-866-342-4089 En Canadá llame al: 1-800-807-6777 www.gladiatorgarageworks.ca

# MOBILE TOOL CHEST COMBO SAFETY

## Your safety and the safety of others are very important.

We have provided many important safety messages in this manual and on your appliance. Always read and obey all safety messages.



This is the safety alert symbol.

This symbol alerts you to potential hazards that can kill or hurt you and others.

All safety messages will follow the safety alert symbol and either the word "DANGER" or "WARNING."

These words mean:

**⚠ DANGER**

You can be killed or seriously injured if you don't immediately follow instructions.

**⚠ WARNING**

You can be killed or seriously injured if you don't follow instructions.

All safety messages will tell you what the potential hazard is, tell you how to reduce the chance of injury, and tell you what can happen if the instructions are not followed.

# DIMENSIONS

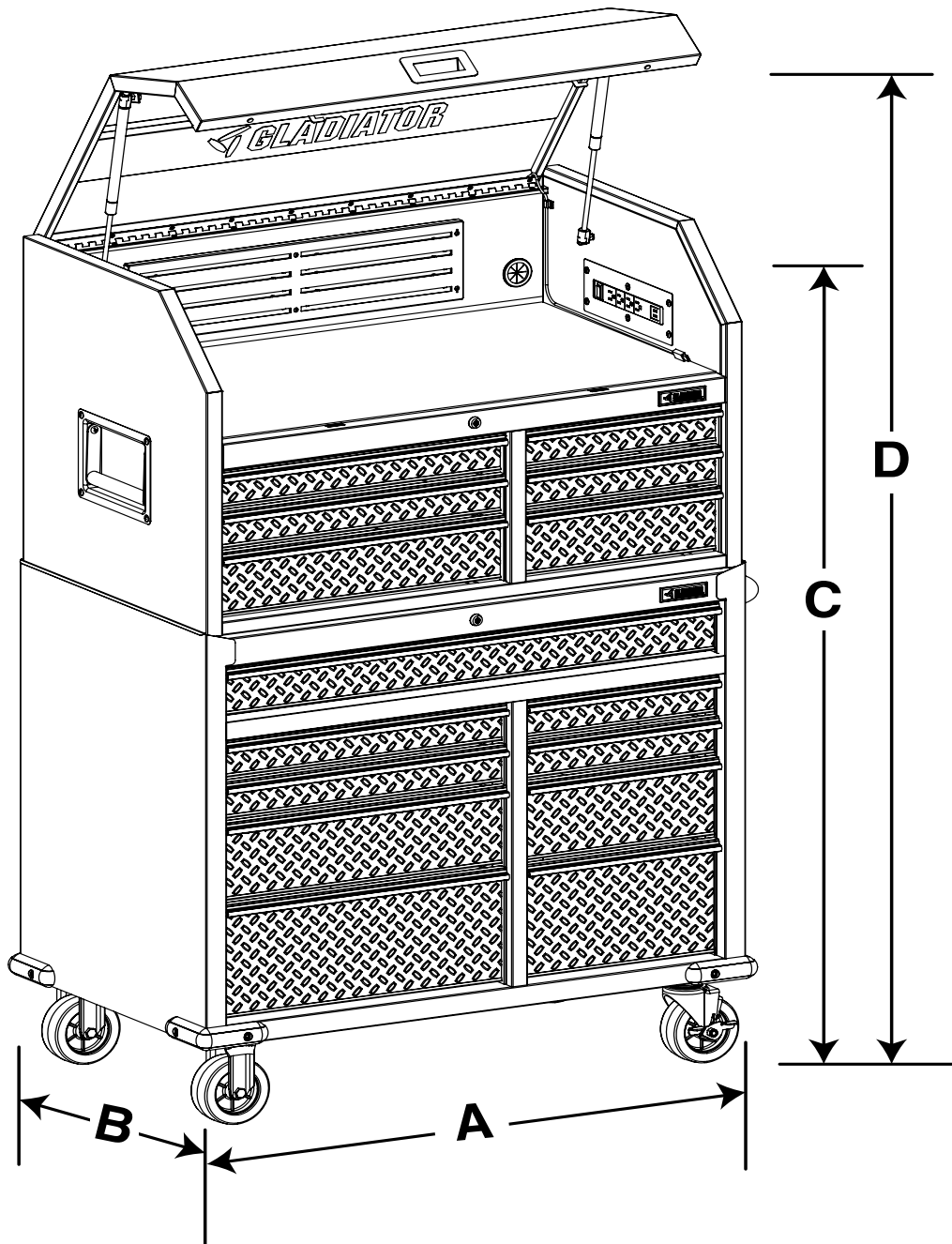

Model	GATC4115JG
A	41" (104 cm)
B	24.5" (62.3 cm)
C	62.5" (159 cm)
D	78" (198 cm)

# TOOL CHEST COMBO USE REQUIREMENTS

- Intended for garage use in a dry location.
- Use caster locks when not being moved.
- Maximum weight limit is 100 lbs (45 kg) for each drawer.
- Maximum weight limit is 1500 lbs (682 kg) for the storage combo.

## ⚠ WARNING



### Tip Over Hazard

**A child or adult can tip the tool chest and be killed.**

**Open only one drawer at a time.**

**Firmly close and lock drawers before moving the tool chest.**

**Tool chests are designed to fit together. Use tool chests as listed in your assembly instructions.**

**Failure to do so can result in serious injury or death.**

# ASSEMBLY INSTRUCTIONS

## TOOLS AND PARTS





- Gather the required tools and parts before starting assembly. Parts are located inside tool cabinet drawer and inside tool chest upper tray.

### TOOLS NEEDED

- Double-sided 10 mm / 12 mm wrench (included)

### PARTS SUPPLIED

- Tool chest
- Tool cabinet
- Cabinet handle
- Fixed casters (2)
- Swivel casters (2)
- Drawer and tray liners (7 for chest / 9 for cabinet)
- Keys (2 for chest / 2 for cabinet)
- LED light / Cable / Mounts
- Bumpers (4)
- F1 - M6 – 1.00 x 15 hex-bolt (4)
- F2 - M8 – 1.25 x 25 hex-bolt (16)
- F4 - 6 mm washer (8)
- F5 - M6 hex-head bolt (8)

F1		M6 – 1.00 x 15 hex-bolt (4)
F2		M8 – 1.25 x 25 hex-bolt (16)
F4		6 mm washer (8)
F5		M6 hex-head bolt (8)

## UNPACK THE TOOL CHEST COMBO

## ⚠ WARNING

### Excessive Weight Hazard

**Use two or more people to move, assemble or install cabinet.**

**Failure to do so can result in back or other injury.**

- Remove the packaging from the Tool Chest Combo chest and cabinet. Parts are located inside the chest upper tray area and cabinet drawer. Verify contents. See “Parts Supplied.”
- Set aside the outer cardboard package from the cabinet for use during assembly.
- After assembly, dispose of all packaging materials properly.

## 1. Attach the Handle

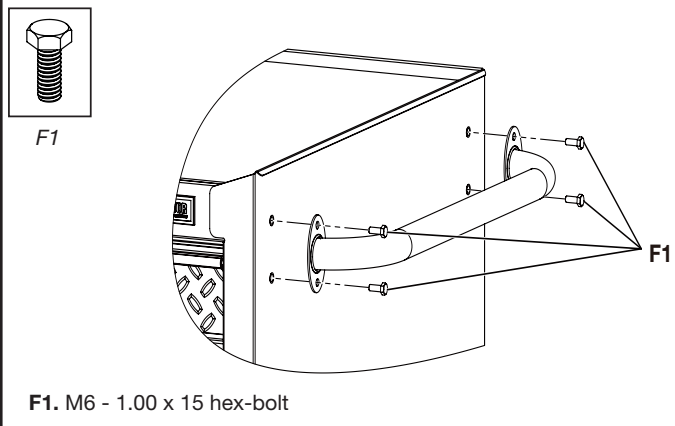

Position the handle over the threaded inserts on the right side of the cabinet. Attach handle with M6-1.00 x 15 hex-bolts (F1) (4) and tighten with 10 mm wrench (provided).

## 2. Attach the Casters

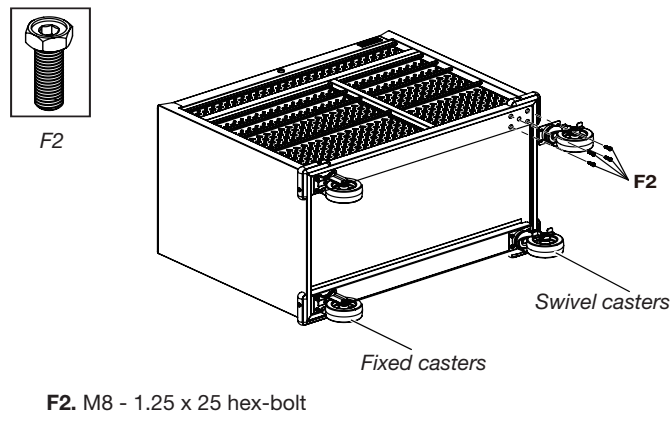

### **⚠ WARNING**

#### **Excessive Weight Hazard**

**Use two or more people to move, assemble or install cabinet.**

**Failure to do so can result in back or other injury.**

Push in all the cabinet drawers fully and lock using the key. Using two or more people, lay the cabinet down on its back with the drawers facing upward. Protect the cabinet back finish by laying it down on the saved cardboard packaging material.

Attach the swivel casters to the cabinet, on the same side as the handle, using M8-1.25 x 25 hex-bolts (F2) (8) and tighten with the provided 12 mm wrench. Attach the fixed casters to the cabinet, on the opposite side as the handle, using M8-1.25 x 25 hex-bolts (F2) (8) and tighten with the provided 12 mm wrench.

# FINAL ASSEMBLY

## ⚠ WARNING

### Excessive Weight Hazard

Use two or more people to move, assemble or install cabinet.

Failure to do so can result in back or other injury.

Using two or more people, lift the cabinet up and onto the casters.

## 1. Bumper Assembly

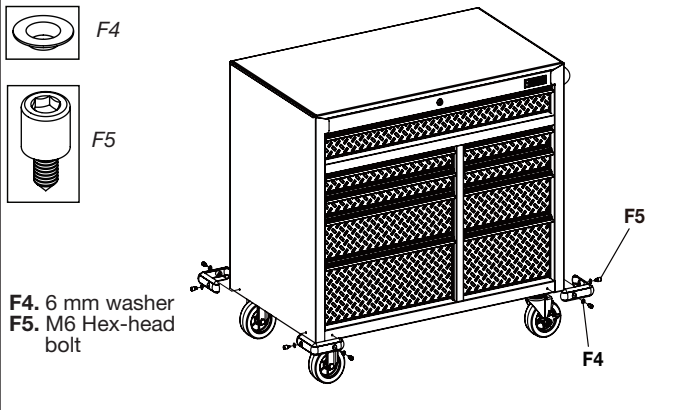

Using 6 mm Hex-head bolts (F5) (8) and 6 mm washers (F4) (8), fasten a bumper to each corner of the cabinet. Completely tighten all the fasteners.

**NOTE:** To keep from stripping the bolts, do not overtighten.

## 3. Use, Remove and Replace the Drawers

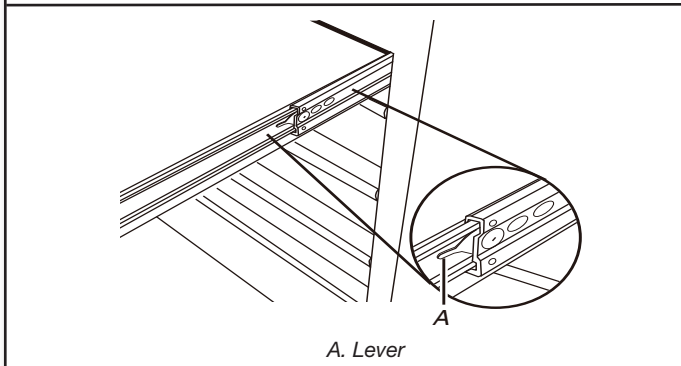

**NOTE:** The key locks the lid and all of the drawers. Use the drawer liners to avoid scratching or damaging the drawers.

### REMOVING THE DRAWER

Unload the contents from the drawer. Slide out the drawer as far as it will go. Press the lever down on the right-hand track and lift the lever up on the left track to release the drawer. Pull the drawer out the rest of the way.

### REPLACING THE DRAWER

Align the drawer guides with the receiving glides. Hold the receiving glides firmly and insert the drawer guide.

**NOTE:** It is normal for the drawer to close tightly the first time after it has been removed.

Push the drawer in completely.

## 2. LED Light Assembly

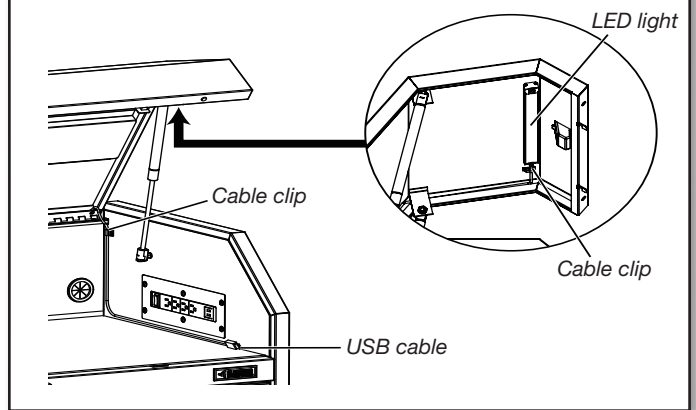

The included LED light is used to illuminate the upper chest tray area. The LED light is magnetic and may be positioned anywhere on the inside flat surface of the lid. The LED light is powered by the USB port on the powerstrip. Route the included USB cable as shown. The wire should be positioned behind the center lid support. Use the two self-adhesive cable clips to hold the USB cable in position as shown. After assembly, make sure the lid closes and the USB cable stays within the tray area and does not contact the hinge, lid opening, or any moving parts.

---

# POWER OUTLET WITH USB

**⚠ WARNING**



**Electrical Shock Hazard**

**Plug into a grounded 3 prong outlet.**

**Do not remove ground prong.**

**Do not use an adapter.**

**Do not use an extension cord.**

**Failure to follow these instructions can result in death, fire, or electrical shock.**

- The powerstrip cord is shipped inside the upper tray area and must be routed through the rubber grommet located on the rear of the tray area.
- Open the tray lid, remove the power cord packaging material, and push the cord power plug through the grommet. Pull the cord through completely.
- A second grommet is located in the back of the tray area and can be used to route additional cords if needed.
- Always unplug power cord when moving or cleaning the tool storage combo.
- Do not insert a cord through a hole without a grommet.
- The powerstrip includes an On/Off switch that has an overload protector rated at 15 A. Do not overload the powerstrip.
- The USB ports can be used to charge cell phones and power USB devices.

**NOTE:** This device complies with Part 15 of the FCC Rules. Operation is subject to the following two conditions:

1. This device may not cause harmful interference.
2. This device must accept any interference received, including interference that may cause undesired operation.

**NOTE:** This equipment has been tested and found to comply with the limits for a Class B digital device, pursuant to Part 15 of the FCC Rules.

These limits are designed to provide reasonable protection against harmful interference in a residential installation. This equipment generates, uses, and can radiate radio frequency energy, and if not installed and used in accordance with the instructions, may cause harmful interference to radio communications. However, there is no guarantee that interference will not occur in a particular installation. If this equipment does cause harmful interference to radio or television reception, which can be determined by turning the equipment off and on, the user is encouraged to try to correct the interference by one or more of the following measures:

- Reorient or relocate the receiving antenna.
- Increase the separation between the equipment and receiver.
- Connect the equipment into an outlet on a circuit different from that to which the receiver is connected.
- Consult the dealer or an experienced radio/TV technician for help.

---

# MAGNETIC TOOL HOLDER

- In the back of the upper tray area is a magnetic tool holder that can be used to hold small tools, that are most used, for easy access.

---

# TOOL CHEST COMBO MAINTENANCE

- Always unplug and remove all cords before cleaning the tool combo.
- The tool storage combo can be cleaned with a mild detergent and water.
- The drawer slides and casters can be lubricated with high-quality bearing grease.
- Remove any grease / oil with a nonflammable cleaner.

---

# REGISTERING YOUR PRODUCT

There are many benefits to registering your product. Find out more and register your product online at:

**[www.gliatorgarageworks.com](http://www.gliatorgarageworks.com).**

Consumers in Canada can call **1-800-807-6777**.

In U.S.A. call **1-866-342-4089**.

In some European factories the letter "W" of the part code mentioned herein will be automatically replaced by the number "4000" (e.g. "W12345678" becomes "400012345678")

# GLADIATOR® TOOL CHEST COMBO WARRANTY

ATTACH YOUR RECEIPT HERE. PROOF OF PURCHASE IS REQUIRED TO OBTAIN WARRANTY SERVICE.

Please have the following information available when you call the Customer eXperience Center:

- Name, address and telephone number
- Model number and serial number
- A clear, detailed description of the problem
- Proof of purchase including dealer or retailer name and address

## IF YOU NEED SERVICE:

1. Before contacting us to arrange service, please determine whether your product requires repair. Some questions can be addressed without service. Please take a few minutes to review the instructions or visit [www.gladiatorgarageworks.com](http://www.gladiatorgarageworks.com).
2. All warranty service is provided exclusively by our authorized Gladiator® Service Providers. In the U.S. and Canada, direct all requests for warranty service to:

**Gladiator® Customer eXperience Center**

**In the U.S.A., call 1-866-342-4089. In Canada, call 1-800-807-6777.**

If outside the 50 United States or Canada, contact your authorized Gladiator® dealer to determine whether another warranty applies.

## LIMITED WARRANTY

### WHAT IS COVERED

#### THREE YEAR LIMITED WARRANTY ON POWERSTRIP

For three years from the date of purchase, when this product is operated and maintained according to the instructions attached to or furnished with the product, Gladiator® will replace or repair the defective product or parts to correct defects in materials or workmanship.

#### LIFETIME LIMITED WARRANTY ON TOOL CHEST COMBO

For the life of the product, when the Tool Chest Combo is used and maintained according to the instructions attached to or furnished with the product, Gladiator will pay for repair or replacement of the defective product or parts to correct defects in materials or workmanship.

### WHAT IS NOT COVERED

1. Service calls to correct the installation of any Gladiator® products or to instruct you on how to use or install them.
2. Damage resulting from improper handling or shipping of products, or products damaged by accident, misuse, abuse, fire, flood, improper installation, acts of God, neglect, corrosion, modification or mishandling.
3. Shipping or freight fees to deliver replacement products or to return defective products.
4. Repairs or replacement when your product is used in other than normal, single-family household use, such as a commercial environment, or handled in any way inconsistent with the installation instructions included with the product.
5. Cosmetic damage including scratches, dings, dents or cracks that do not affect the structural or functional capability of the product.
6. Replacement parts or product for Gladiator® products operated outside the United States and Canada.
7. In Canada, travel or transportation expenses for customers who reside in remote areas.
8. Any labor costs during the limited warranty period.
9. Damage resulting from improper loading beyond the specified maximum weight capacity outlined in the assembly instructions provided with the product.
10. Surfaces damaged due to chemical interaction resulting in corrosion of paint or metal.

**The cost of repair or replacement under these excluded circumstances shall be borne by the customer.**

## DISCLAIMER OF IMPLIED WARRANTIES; LIMITATION OF REMEDIES

IMPLIED WARRANTIES, INCLUDING TO THE EXTENT APPLICABLE WARRANTIES OF MERCHANTABILITY OR FITNESS FOR A PARTICULAR PURPOSE, ARE EXCLUDED TO THE EXTENT LEGALLY PERMISSIBLE. ANY IMPLIED WARRANTIES THAT MAY BE IMPOSED BY LAW ARE LIMITED TO ONE YEAR, OR THE SHORTEST PERIOD ALLOWED BY LAW. SOME STATES AND PROVINCES DO NOT ALLOW LIMITATIONS OR EXCLUSIONS ON HOW LONG AN IMPLIED WARRANTY OF MERCHANTABILITY OR FITNESS LASTS, SO THE ABOVE LIMITATIONS OR EXCLUSIONS MAY NOT APPLY TO YOU. THIS WARRANTY GIVES YOU SPECIFIC LEGAL RIGHTS, AND YOU MAY ALSO HAVE OTHER RIGHTS WHICH VARY FROM STATE TO STATE OR PROVINCE TO PROVINCE.

Outside the 50 United States and Canada, this warranty does not apply. Contact your authorized Gladiator dealer to determine if another warranty applies.

If you need service, call the Gladiator Customer eXperience Center, **1-866-342-4089** (toll-free), from anywhere in the U.S.A. In Canada, contact your Whirlpool Canada LP designated service company or call **1-800-807-6777**.

In the United States, Gladiator means Whirlpool Corporation, Benton Harbor, Michigan 49022. In Canada, Gladiator means Whirlpool Canada LP, Mississauga, ON L5N 3A7.

**Keep this book and your sales slip together for future reference. You must provide proof of purchase or installation date for in-warranty service.**

Write down the following information about your Tool Chest Combo to better help you obtain assistance or service if you ever need it. You will need to know your complete model number and serial number. You can find this information on the model and serial label located on the back of the product.

Dealer name \_\_\_\_\_

Address \_\_\_\_\_

Phone number \_\_\_\_\_

Model number \_\_\_\_\_

Serial number \_\_\_\_\_

Purchase date \_\_\_\_\_