



GLADIATOR®

MODEL/MODÈLE/ MODELO:
GAMT41HWJG

PREMIER 41" 9-DRAWER MOBILE WORKBENCH WITH HARDWOOD TOP

Assembly Instructions

ÉTABLI MOBILE À 9 TIROIRS DE 41" AVEC DESSUS EN BOIS MASSIF

Instructions d'assemblage

BANCO DE TRABAJO MÓVIL DE CALIDAD SUPERIOR DE 41" CON 9 CAJONES Y SUPERFICIE DE MADERA MACIZA

Instrucciones de ensamblaje

TABLE OF CONTENTS/TABLE DES MATIÈRES/ÍNDICE

MOBILE WORKBENCH SAFETY	2	SÉCURITÉ DE L'ÉTABLI MOBILE.....	9	SEGURIDAD DEL BANCO DE	
DIMENSIONS	3	DIMENSIONS	10	TRABAJO MÓVIL	17
MOBILE WORKBENCH USE		CONDITIONS D'UTILISATION		DIMENSIONES	18
REQUIREMENTS	4	DE L'ÉTABLI MOBILE.....	11	REQUISITOS DE USO DEL BANCO DE	
ASSEMBLY INSTRUCTIONS.....	4	INSTRUCTIONS D'ASSEMBLAGE.....	11	TRABAJO MÓVIL	19
FINAL ASSEMBLY.....	6	ASSEMBLAGE FINAL	13	INSTRUCCIONES DE ENSAMBLAJE	19
POWER OUTLET WITH USB.....	7	PRISE DE COURANT AVEC USB.....	14	MONTAJE FINAL.....	21
MOBILE WORKBENCH		MAINTENANCE DE L'ÉTABLI MOBILE	14	TOMA DE CORRIENTE CON USB	22
MAINTENANCE.....	7	ENREGISTREMENT DE		MANTENIMIENTO DE BANCO DE	
REGISTERING YOUR		VOTRE PRODUIT	14	TRABAJO MÓVIL	22
PRODUCT.....	7	GARANTIE	15	CÓMO REGISTRAR EL PRODUCTO	22
WARRANTY	8			GARANTÍA.....	23

MOBILE WORKBENCH SAFETY

Your safety and the safety of others are very important.

We have provided many important safety messages in this manual and on your appliance. Always read and obey all safety messages.



This is the safety alert symbol.

This symbol alerts you to potential hazards that can kill or hurt you and others.

All safety messages will follow the safety alert symbol and either the word "DANGER" or "WARNING."

These words mean:

⚠ DANGER

You can be killed or seriously injured if you don't immediately follow instructions.

⚠ WARNING

You can be killed or seriously injured if you don't follow instructions.

All safety messages will tell you what the potential hazard is, tell you how to reduce the chance of injury, and tell you what can happen if the instructions are not followed.

DIMENSIONS

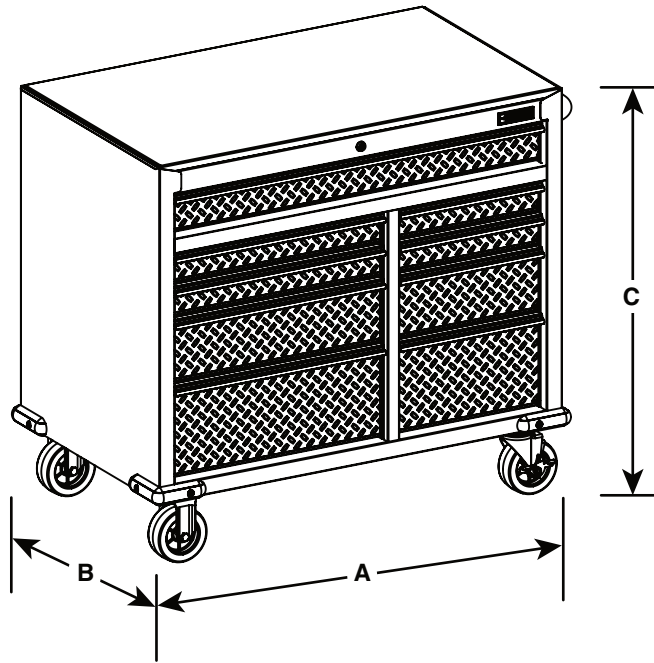

Model	GAMT41HWJG
A	41" (104 cm)
B	24.5" (62.3 cm)
C	38" (97 cm)

MOBILE WORKBENCH USE REQUIREMENTS

- Intended for garage use in a dry location.
- Use caster locks when not being moved.
- Maximum weight limit is 100 lbs (45 kg) for each drawer.
- Maximum weight limit for mobile workbench is 1500 lbs (682 kg).

ASSEMBLY INSTRUCTIONS

TOOLS AND PARTS



- Gather the required tools and parts before starting assembly. Parts are located inside tool cabinet.

TOOLS NEEDED

- Double-sided 10 mm / 12 mm wrench (included)
- Philips screwdriver
- Hex key

PARTS SUPPLIED

- Mobile workbench
- Cord storage hook (2)
- Cabinet handle
- Fixed casters (2)
- Swivel casters (2)
- Drawer and tray liners (9)
- Keys (2)
- Bumpers (4)
- F1 - M6 – 1.00 x 15 hex bolt (4)
- F2 - M8 – 1.25 x 25 hex bolt (16)
- F3 – M6 – 1.00 x 12 pan-head Philips screw (4)
- F4 - 6 mm washer (8)
- F5 - M6 hex-head bolt (8)

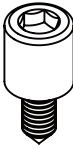
F3		M6 – 1.00 x 12 pan-head Philips screw (4)
F4		6 mm washer (8)
F5		M6 hex-head bolt (8)

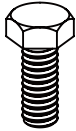
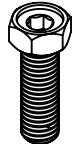
F1		M6 – 1.00 x 15 hex bolt (4)
F2		M8 – 1.25 x 25 hex bolt (16)

UNPACK THE MOBILE WORKBENCH

⚠ WARNING

Excessive Weight Hazard

Use two or more people to move and assemble workbench.

Failure to do so can result in back or other injury.

- Remove the packaging from the mobile workbench. Parts are located inside the cabinet drawer. Verify contents. See “Parts Supplied.”
- Set aside the outer cardboard package for use during assembly.
- After assembly, dispose of all packaging materials properly.

1. Attach the Handle

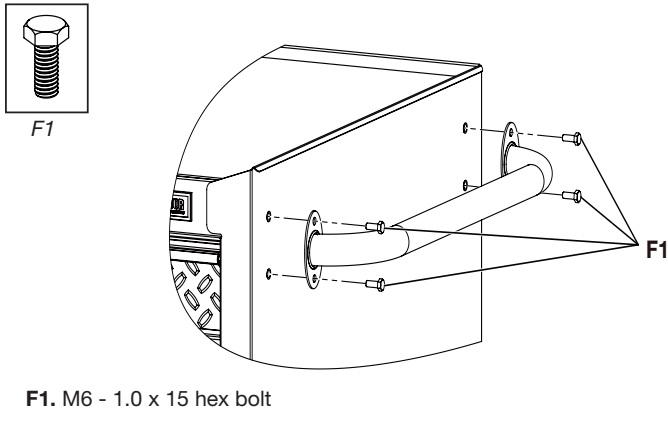

Position the handle over the threaded inserts on the side of the cabinet. Attach handle with M6-1.00 x 15 Hex bolts (F1) (4) and tighten with 10 mm wrench (provided).

2. Attach Cord Storage Hooks

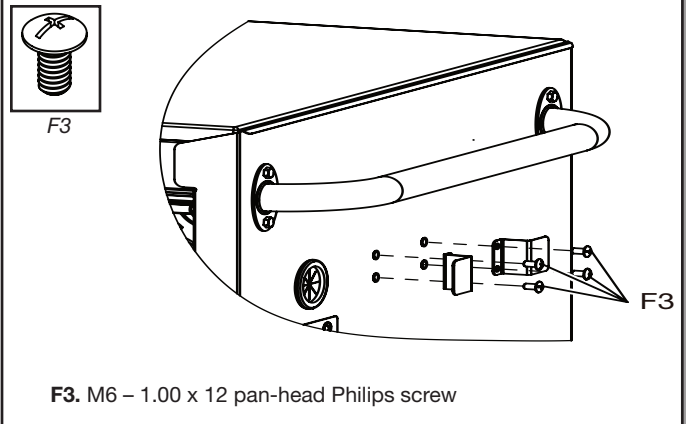

Position the cord storage hooks over the threaded inserts on handle side of the cabinet. Using M6-1.00 x 12 pan-head Philips screws (F3) (4) attach the hooks facing opposite of each other. Tighten the screws with a Philips screwdriver.

3. Attach the Casters

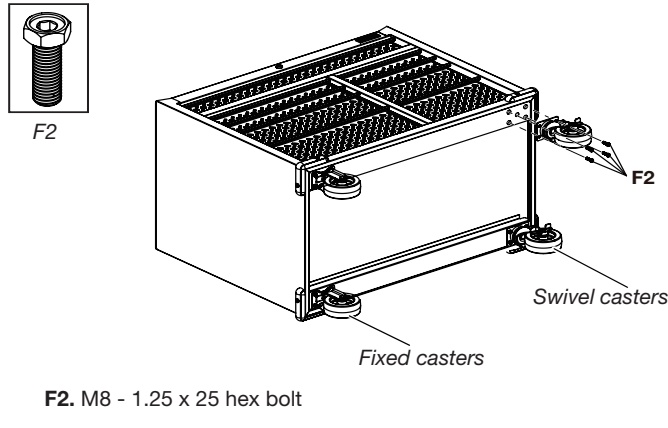

⚠ WARNING

Excessive Weight Hazard

Use two or more people to move and assemble workbench.

Failure to do so can result in back or other injury.

Push in all the cabinet drawers fully and lock using the key. Using two or more people, lay the cabinet down on its back with the drawers facing upward. Protect the cabinet back finish by laying it down on the saved cardboard packaging material. Attach the swivel casters to the cabinet, on the same side as the handle, using M8-1.25 x 25 hex bolts (F2) (8) and tighten with the provided 12 mm wrench. Attach the fixed casters to the cabinet, on the opposite side as the handle, using M8-1.25 x 25 hex bolts (F2) (8) and tighten with the provided 12 mm wrench.

FINAL ASSEMBLY

⚠ WARNING

Excessive Weight Hazard

Use two or more people to move and assemble workbench.

Failure to do so can result in back or other injury.

Using two or more people, lift the mobile workbench up and onto the casters.

1. Bumper Assembly

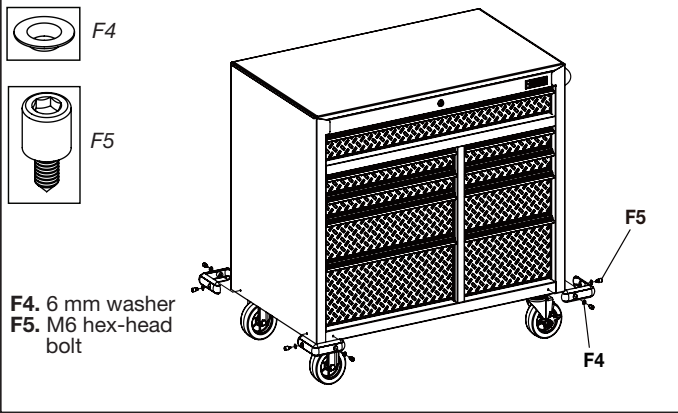

Using 6 mm hex head bolts (F5) (8) and 6 mm washers (F4) (8), fasten a bumper to each corner of the cabinet. Completely tighten all the fasteners.

NOTE: To keep from stripping the bolts, do not overtighten.

2. Use, Remove and Replace the Drawers

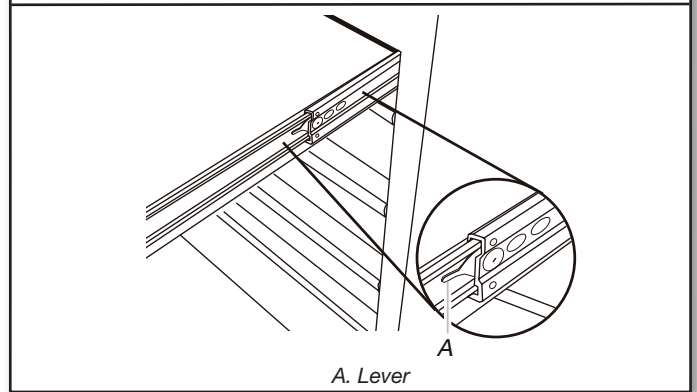

NOTE: The key locks all of the drawers. Use the drawer liners to avoid scratching or damaging the drawers.

REMOVING THE DRAWER

Unload the contents from the drawer. Slide out the drawer as far as it will go. Press the lever down on the right-hand track and lift the lever up on the left track to release the drawer. Pull the drawer out the rest of the way.

REPLACING THE DRAWER

Align the drawer guides with the receiving glides. Hold the receiving glides firmly and insert the drawer guide.

NOTE: It is normal for the drawer to close tightly the first time after it has been removed. Push the drawer in completely.

POWER OUTLET WITH USB

⚠ WARNING



Electrical Shock Hazard

Plug into a grounded 3 prong outlet.

Do not remove ground prong.

Do not use an adapter.

Do not use an extension cord.

Failure to follow these instructions can result in death, fire, or electrical shock.

- The powerstrip cord is shipped outside the right side and must be routed through the rubber grommet located above the powerstrip.
- Remove the power cord packaging material and pull the cord power plug through the grommet completely.
- Do not insert a cord through a hole without a grommet.
- Always unplug power cord when moving or cleaning the mobile workbench.
- The mobile workbench includes cord hooks that allow for cord storage.
- The powerstrip includes an on/off switch that has an overload protector rated at 15 A. Do not overload the powerstrip.
- The USB ports can be used to charge cell phones and power USB devices.

NOTE: This device complies with Part 15 of the FCC Rules. Operation is subject to the following two conditions:

1. This device may not cause harmful interference, and
2. This device must accept any interference received, including interference that may cause undesired operation.

NOTE: This equipment has been tested and found to comply with the limits for a Class B digital device, pursuant to Part 15 of the FCC Rules.

These limits are designed to provide reasonable protection against harmful interference in a residential installation. This equipment generates, uses, and can radiate radio frequency energy, and if not installed and used in accordance with the instructions, may cause harmful interference to radio communications. However, there is no guarantee that interference will not occur in a particular installation. If this equipment does cause harmful interference to radio or television reception, which can be determined by turning the equipment off and on, the user is encouraged to try to correct the interference by one or more of the following measures:

- Reorient or relocate the receiving antenna.
- Increase the separation between the equipment and receiver.
- Connect the equipment into an outlet on a circuit different from that to which the receiver is connected.
- Consult the dealer or an experienced radio/TV technician for help.

MOBILE WORKBENCH MAINTENANCE

- Always unplug and remove all cords before cleaning the mobile workbench.
- The mobile workbench may be cleaned with a mild detergent and water.
- The drawer slides and casters can be lubricated with high-quality bearing grease.
- Remove any grease or oil with a non-flammable cleaner.

REGISTERING YOUR PRODUCT

There are many benefits to registering your product. Find out more and register your product online at:

www.gladiatorgarageworks.com.

Consumers in Canada can call **1-800-807-6777**.

In the U.S.A. call **1-866-342-4089**.

GLADIATOR® MOBILE WORKBENCH WARRANTY

ATTACH YOUR RECEIPT HERE. PROOF OF PURCHASE IS REQUIRED TO OBTAIN WARRANTY SERVICE.

Please have the following information available when you call the Customer eXperience Center:

- Name, address and telephone number
- Model number and serial number
- A clear, detailed description of the problem
- Proof of purchase including dealer or retailer name and address

IF YOU NEED SERVICE:

1. Before contacting us to arrange service, please determine whether your product requires repair. Some questions can be addressed without service. Please take a few minutes to review the instructions or visit www.gladiatorgarageworks.com.
2. All warranty service is provided exclusively by our authorized Gladiator® Service Providers. In the U.S. and Canada, direct all requests for warranty service to:

Gladiator Customer eXperience Center

In the U.S.A., call 1-866-342-4089. In Canada, call 1-800-807-6777.

If outside the 50 United States or Canada, contact your authorized Gladiator dealer to determine whether another warranty applies.

ONE YEAR LIMITED WARRANTY

WHAT IS COVERED

ONE YEAR LIMITED WARRANTY ON WOOD TOP

For one year from the date of purchase, when this product is operated and maintained according to the instructions attached to or furnished with the product, Gladiator® will replace or repair the defective product or parts to correct defects in materials or workmanship.

THREE YEAR LIMITED WARRANTY ON POWERSTRIP

For three years from the date of purchase, when this product is operated and maintained according to the instructions attached to or furnished with the product, Gladiator® will replace or repair the defective product or parts to correct defects in materials or workmanship.

LIFETIME LIMITED WARRANTY ON MOBILE WORKBENCH

For the life of the product, when the Workbench is used and maintained according to the instructions attached to or furnished with the product, Gladiator will pay for repair or replacement of the defective product or parts to correct defects in materials or workmanship.

WHAT IS NOT COVERED

1. Service calls to correct the installation of any Gladiator® products or to instruct you on how to use or install them.
2. Damage resulting from improper handling or shipping of products, or products damaged by accident, misuse, abuse, fire, flood improper installation, acts of God, neglect, corrosion, modification or mishandling.
3. Shipping or freight fees to deliver replacement products or to return defective products.
4. Repairs or replacement when your product is used in other than normal, single-family household use, such as a commercial environment or handled in any way inconsistent with the installation instructions included with the product.
5. Cosmetic damage including scratches, dings, dents or cracks that do not affect the structural or functional capability of the product.
6. Replacement parts or product for Gladiator® products operated outside the United States and Canada.
7. In Canada, travel or transportation expenses for customers who reside in remote areas.
8. Any labor costs during the limited warranty period.
9. Damage resulting from improper loading beyond the specified maximum weight capacity outlined in the assembly instructions provided with the product.
10. Surfaces damaged due to chemical interaction resulting in corrosion of paint or metal.
11. Any damage, splitting, cracking or warping of the wooden top past the first year.

The cost of repair or replacement under these excluded circumstances shall be borne by the customer.

DISCLAIMER OF IMPLIED WARRANTIES; LIMITATION OF REMEDIES

IMPLIED WARRANTIES, INCLUDING TO THE EXTENT APPLICABLE WARRANTIES OF MERCHANTABILITY OR FITNESS FOR A PARTICULAR PURPOSE, ARE EXCLUDED TO THE EXTENT LEGALLY PERMISSIBLE. ANY IMPLIED WARRANTIES THAT MAY BE IMPOSED BY LAW ARE LIMITED TO ONE YEAR, OR THE SHORTEST PERIOD ALLOWED BY LAW. SOME STATES AND PROVINCES DO NOT ALLOW LIMITATIONS OR EXCLUSIONS ON HOW LONG AN IMPLIED WARRANTY OF MERCHANTABILITY OR FITNESS LASTS, SO THE ABOVE LIMITATIONS OR EXCLUSIONS MAY NOT APPLY TO YOU. THIS WARRANTY GIVES YOU SPECIFIC LEGAL RIGHTS, AND YOU MAY ALSO HAVE OTHER RIGHTS WHICH VARY FROM STATE TO STATE OR PROVINCE TO PROVINCE.

Outside the 50 United States and Canada, this warranty does not apply. Contact your authorized Gladiator dealer to determine if another warranty applies.

If you need service, call the Gladiator Customer eXperience Center, **1-866-342-4089** (toll-free), from anywhere in the U.S.A. In Canada, contact your Whirlpool Canada LP designated service company or call **1-800-807-6777**.

In the United States, Gladiator means Whirlpool Corporation, Benton Harbor, Michigan 49022. In Canada, Gladiator means Whirlpool Canada LP, Mississauga, ON L5N 3A7.

Keep this book and your sales slip together for future reference. You must provide proof of purchase or installation date for in-warranty service.

Write down the following information about your Workbench to better help you obtain assistance or service if you ever need it. You will need to know your complete model number and serial number. You can find this information on the model and serial label located on the back of the product.

Dealer name _____

Address _____

Phone number _____

Model number _____

Serial number _____

Purchase date _____