



**ALL REFRIGERATOR
AND UPRIGHT FREEZER**
Use and Care Guide

**TOUS LES
RÉFRIGÉRATEURS
ET CONGÉLATEURS
VERTICAUX**
Guide d'utilisation et
d'entretien

TABLE OF CONTENTS...2 / TABLE DES MATIÈRES...20

TABLE OF CONTENTS

REFRIGERATOR AND FREEZER SAFETY	3	CARING FOR YOUR REFRIGERATOR OR FREEZER	14
Proper Disposal of Your Old Refrigerator or Freezer	4	Registering Your Unit	14
INSTALLING YOUR REFRIGERATOR OR FREEZER	5	Refrigerator and Freezer Features	14
Unpacking.....	5	Cleaning Your Refrigerator or Auto-Defrosting Freezer	14
Cleaning Before Use.....	5	Changing the Light Bulb(s).....	15
Location Requirements.....	5	Power Interruptions	15
Tools.....	5	Vacation and Moving Care.....	15
Electrical Requirements.....	6	TROUBLESHOOTING	16
Removing the Unit Door	6	Refrigerator Operation	17
Replacing the Unit Door	6	Freezer Operation	18
Reversing the Unit Door.....	7	GLADIATOR® GARAGEWORKS	
Installing the Heavy Duty Casters and Silver Tread Foot Pedals	8	MAJOR APPLIANCE WARRANTY	19
OPERATING YOUR REFRIGERATOR OR FREEZER	11		
Normal Sounds	11		
Ensuring Proper Air Circulation.....	11		
Using the Refrigerator Control	12		
Using the Freezer Control.....	13		

REFRIGERATOR AND FREEZER SAFETY

Your safety and the safety of others are very important.

We have provided many important safety messages in this manual and on your appliance. Always read and obey all safety messages.



This is the safety alert symbol.

This symbol alerts you to potential hazards that can kill or hurt you and others.

All safety messages will follow the safety alert symbol and either the word "DANGER" or "WARNING." These words mean:

⚠ DANGER

You can be killed or seriously injured if you don't immediately follow instructions.

⚠ WARNING

You can be killed or seriously injured if you don't follow instructions.

All safety messages will tell you what the potential hazard is, tell you how to reduce the chance of injury, and tell you what can happen if the instructions are not followed.

IMPORTANT SAFETY INSTRUCTIONS

WARNING: To reduce the risk of fire, electric shock or injury to persons when using the appliance, follow basic precautions, including the following:

- Plug into a grounded 3-prong outlet.
- Do not remove the ground prong.
- Do not use an adapter.
- Do not use an extension cord.
- Disconnect power before servicing.
- Replace all parts and panels before operating.
- Remove doors from your old appliance.
- Use non-flammable cleaner.
- Keep flammable materials and vapors, such as gasoline, well away from the appliance.
- Use two or more people to move and install the appliance.
- Disconnect the power before installing the ice maker (on ice maker kit-ready models only).
- Ice maker kit ECKMF95 can be added to some models.
- A qualified service technician must install the water line and ice maker. See installation instructions supplied with ice maker kit ECKMF95 for complete details.
- Connect to a potable water supply only.
- This appliance is not intended for use by persons (including children) with reduced physical, sensory or mental capabilities, or lack of experience and knowledge, unless they have been given supervision or instruction concerning use of the appliance by a person responsible for their safety.
- Children should be supervised to ensure that they do not play with the appliance.
- If the supply cord is damaged, it must be replaced by the manufacturer, its service agent or similarly qualified person in order to avoid a hazard.
- Do not store explosive substances such as aerosol can with a flammable propellant in this appliance.
- This appliance is intended to be used in household and similar applications such as
 - Staff kitchen areas in shops, offices and other working environments;
 - Farm houses and by clients in hotels, motels and other residential type environments;
 - Bed and breakfast type environments;
 - Catering and similar non-retail applications.

PLEASE KEEP THESE INSTRUCTIONS

Proper Disposal of Your Old Refrigerator or Freezer

! WARNING

Suffocation Hazard

Remove doors from your old refrigerator.

Failure to do so can result in death or brain damage.

Important information to know about disposal of refrigerants:

Dispose of refrigerator in accordance with Federal and Local regulations. Refrigerants must be evacuated by a licensed, EPA certified refrigerant technician in accordance with established procedures.

IMPORTANT: Child entrapment and suffocation are not problems of the past. Junked or abandoned refrigerators and freezers are still dangerous – even if they will sit for “just a few days.” If you are getting rid of your old refrigerator or freezer, please follow these instructions to help prevent accidents.

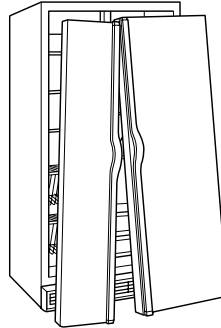

Before You Throw Away Your Old Refrigerator or Freezer:

- Take off the doors or lid.
- Leave the shelves in place so that children may not easily climb inside.

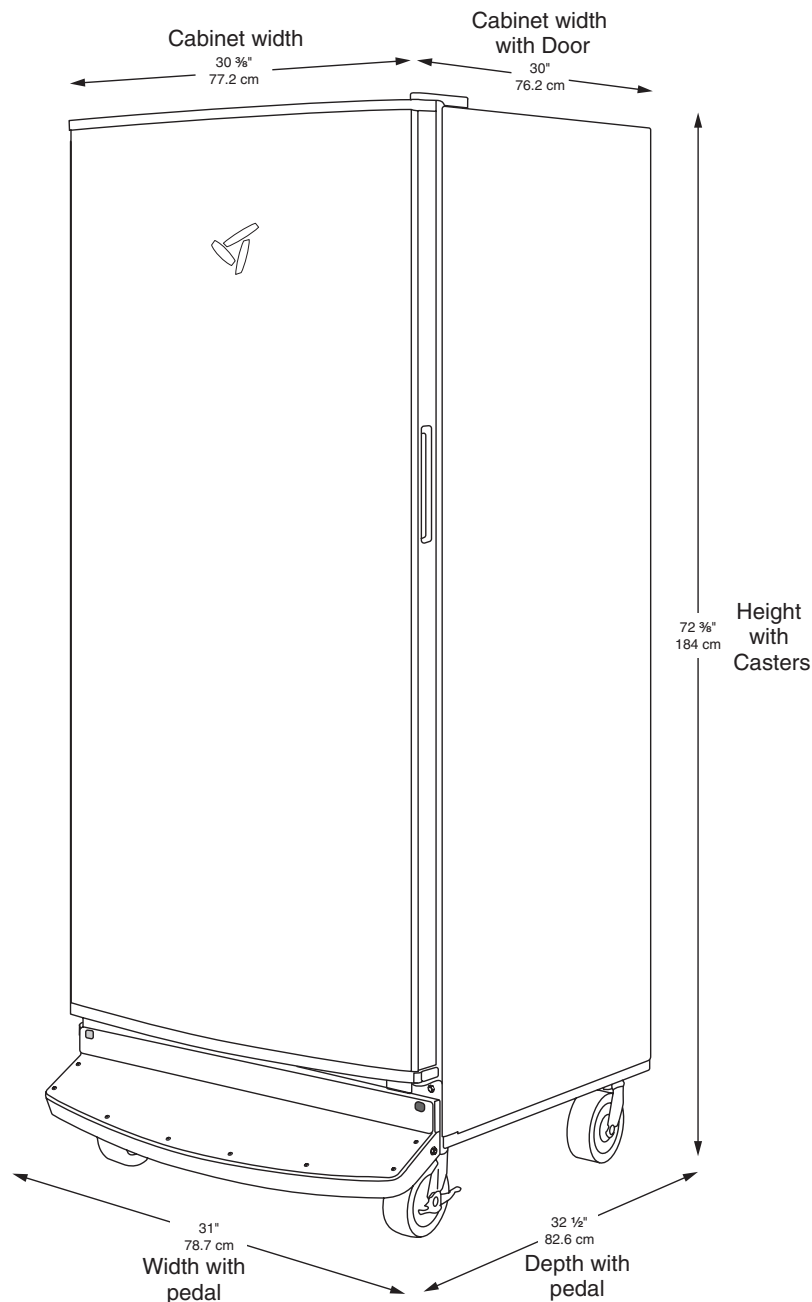

INSTALLING YOUR REFRIGERATOR OR FREEZER

Unpacking

⚠️ WARNING

Excessive Weight Hazard

Use two or more people to move and install refrigerator/freezer.

Failure to do so can result in back or other injury.

- Remove and recycle or discard all packaging materials except for the foam corner posts, which will be used for installation.
- Remove tape and glue residue from surfaces before turning on the refrigerator or freezer. Rub a small amount of liquid dish soap over the adhesive with your fingers. Wipe with warm water and dry.
- Do not use sharp instruments, rubbing alcohol, flammable fluids, or abrasive cleaners to remove tape or glue. These products can damage the surface of your refrigerator or freezer. For more information, see the "Safety" section.

When Moving Your Refrigerator:

Your refrigerator is heavy. When moving the refrigerator for cleaning or service, be sure to cover the floor with cardboard or hardboard to avoid floor damage. Always pull the refrigerator straight out when moving it. Do not wiggle or "walk" the refrigerator when trying to move it, as floor damage could occur.

Cleaning Before Use

After you remove all of the packaging materials, clean the inside of your refrigerator or freezer before using it. See the cleaning instructions in the "Caring For Your Refrigerator or Freezer" section.

Important information to know about glass shelves and covers:

Do not clean glass shelves or covers with warm water when they are cold. Shelves and covers may break if exposed to sudden temperature changes or impact, such as bumping. Tempered glass is designed to shatter into many small, pebble-size pieces. This is normal. Glass shelves and covers are heavy. Use both hands when removing them to avoid dropping.

Location Requirements

⚠️ WARNING



Explosion Hazard

Keep flammable materials and vapors, such as gasoline, away from refrigerator.

Failure to do so can result in death, explosion, or fire.

Ventilation and Clearance

Refrigerator

- Keep flammable materials and vapors, such as gasoline, away from refrigerator.
- Do not cover the refrigerator with items such as blankets, sheets, tablecloths, etc. This reduces air circulation.
- Allow at least 1" (25.4 mm) between the back of the refrigerator and the wall. If the refrigerator is to be next to a fixed wall, leave extra space on the hinge side so the door can open wider.

Freezer

- Keep flammable materials and vapors, such as gasoline, away from freezer.
- Do not cover the freezer with items such as blankets, sheets, tablecloths, etc. This reduces air circulation.
- Allow at least 3" (7.5 cm) of air space at the top and on both sides of the freezer and 1" (2.5 cm) between the back of the freezer and the wall. If the freezer is to be next to a fixed wall, leave extra space on the hinge side so the door can open wider.

Temperature

Your appliances operates most efficiently when located in an area where the temperature will not fall below 40°F (5°C). Place your appliances in a location where the temperature will not fall below this recommended temperature.

Upon Moving To Final Location

Refrigerator

NOTE: Allow for 1" (2.54 cm) space between the back of the refrigerator and the wall.

Freezer

NOTE: Allow for a 3" (7.5 cm) clearance at the top and sides and 1" (2.5 cm) between the back and wall.

Tools

Gather the required tools before assembly:

- 5/16" hex-head socket wrench
- 3/8" hex-head socket wrench
- 2" flat putty knife
- Phillips screwdriver
- 1/2" wrench
- TORX T25[†] screwdriver
- TORX T40[†] screwdriver
- 3/8" Combination wrench

Helpful Tools:

- Electric screwdriver
- 3/8" ratchet wrench

Electrical Requirements

⚠ WARNING



Electrical Shock Hazard

Plug into a grounded 3 prong outlet.

Do not remove ground prong.

Do not use an adapter.

Do not use an extension cord.

Failure to follow these instructions can result in death, fire, or electrical shock.

Before you move your refrigerator or freezer into its final location, it is important to make sure you have the proper electrical connection.

Recommended Grounding Method

A 115 V, 60 Hz, AC only, 15 or 20 A fused, grounded electrical supply is required. It is recommended that a separate circuit serving only your refrigerator or freezer be provided. Use an outlet that cannot be turned off by a switch. Do not use an extension cord.

NOTE: Before performing any type of installation, cleaning, or removing a light bulb, press and hold TEMP SETTING for 3 seconds to turn off cooling, and then disconnect the refrigerator or freezer from the electrical source.

Removing the Unit Door (optional)

This unit comes from the factory with a right swing door. If desired, follow these steps to reverse to a left-swing door.

IMPORTANT:

- Depending on the width of the opening, you may need to remove the handle or door to move the unit into the house.
- All graphics referenced in the following instructions are included later in this section after the “Final Steps” section. The graphic may be reversed if the door swing is reversed.
- Before you begin, turn the control off, remove food, and adjust the door or utility bins from door.

1. Remove Hinge Parts And Door

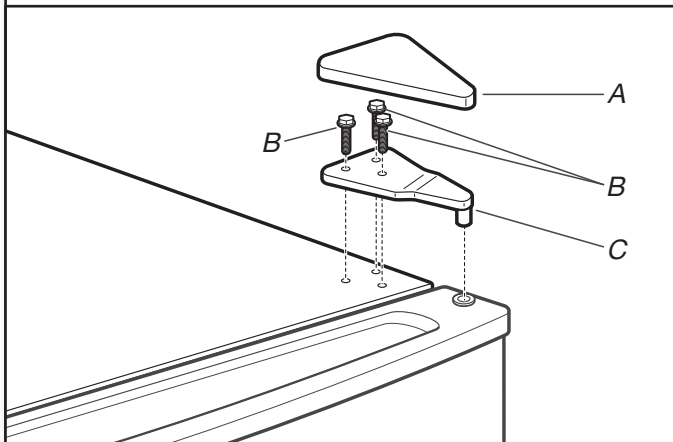

- A. Top Hinge Cover
- B. 5/16" Hex-Head Hinge Screws
- C. Top Hinge

Unplug the refrigerator or freezer or disconnect the power. Keep the unit door closed until you are ready to lift it free from the cabinet. Remove the parts for the top hinge. Lift the unit door free from the lower hinge and cabinet and set aside.

2. Remove Bottom Hinge Parts

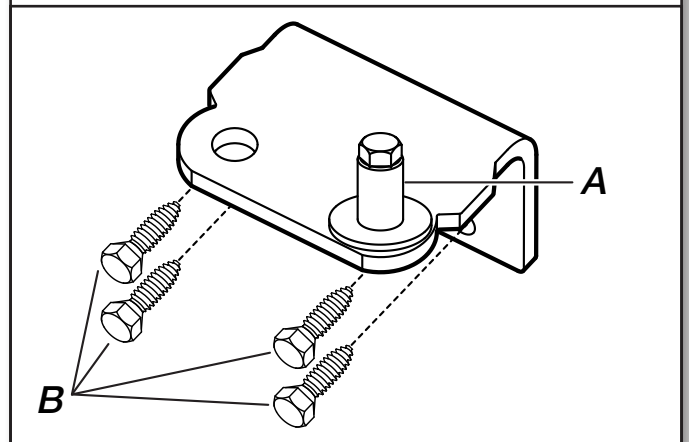

- A. Hinge Pin
- B. 3/8" Hex-Head Hinge Screws

Remove the four hex-head hinge screws and bottom hinge assembly.

NOTE: Provide additional support for the door while the hinges are being moved. Do not depend on the door magnets to hold the door in place while you are working.

Replacing the Unit Door (optional)

Replace the bottom hinge parts from step 2 onto the unit. Then replace the rest of the hinge parts and the door from step 1.

Reversing the Unit Door (optional)

Refer to step 1 and 2 from the "Removing the Unit Door" section.

3. Remove Cabinet Hinge Hole Plugs

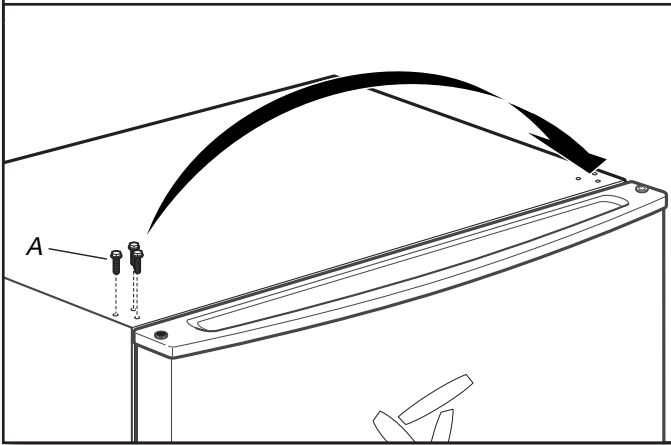

A. Cabinet Hinge Hole Plugs

Using the putty knife, remove cabinet hinge hole plugs from the cabinet top and move them to the opposite side hinge holes. If one breaks, there are replacement parts in your literature kit.

4. Remove Door Hole Plugs

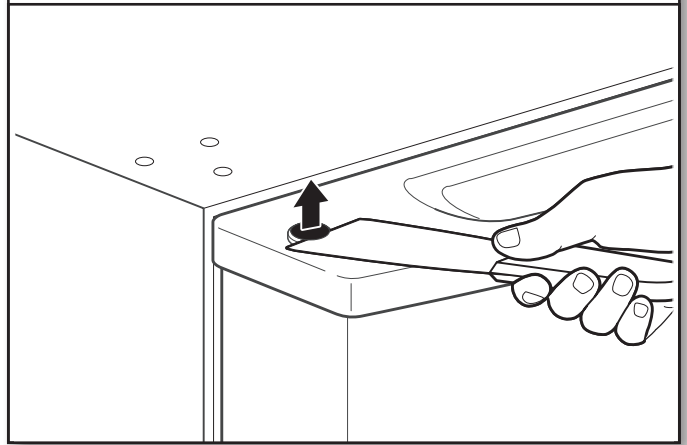

Using the putty knife, remove the door hole plugs from the door. Place the putty knife in between the black plug and clear base, and pry outwards, and place the plug in the hole on the opposite side of the door.

5. Replace Bottom Hinge

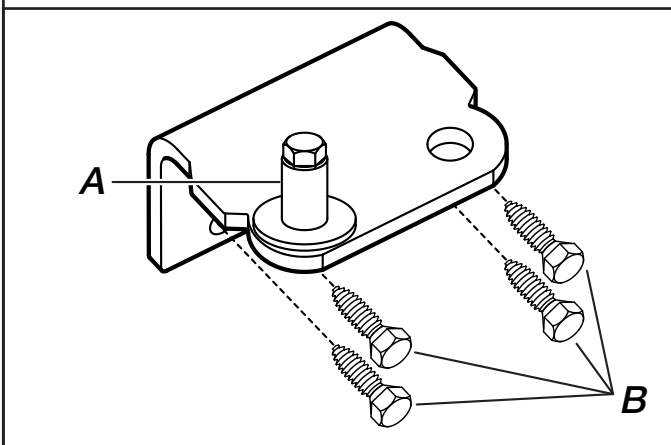

A. Bottom Hinge Pin
B. 3/8" Hex-Head Hinge Screws

Replace the four 3/8" hex head hinge screws on the opposite side, as shown, and tighten the screws.

NOTE: On the reversed door only, switch bottom hinge pin after the bracket side has been switched.

Using the 5/16" nut driver, switch the bottom hinge pin (A) to the opposite hole and tighten, as shown.

6. Replace Door And Top Hinge

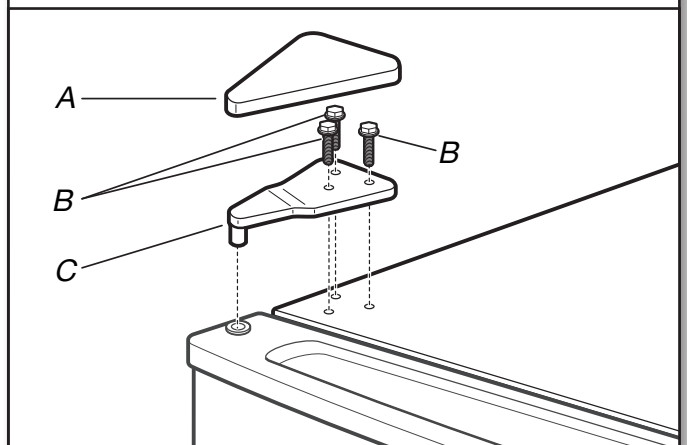

A. Top Hinge Cover
B. 5/16" Hex-Head Hinge Screws
C. Top Hinge

Replace door on bottom hinge pin from previous step.

NOTE: Provide additional support for the door while the hinges are being moved. Do not depend on the door magnets to hold the door in place while you are working.

Assemble the parts of the top hinge as shown above. Tighten the screws completely.

Check all holes to make sure that the hole plugs and screws are in place. Reinstall the top hinge cover.

Installing the Heavy Duty Casters and Silver Tread Foot Pedals

NOTE: Before installing the foot pedal, adjust the door swing direction, if desired.

⚠ WARNING

Excessive Weight Hazard

Use two or more people to move and install refrigerator/freezer.

Failure to do so can result in back or other injury.

1. Preparation

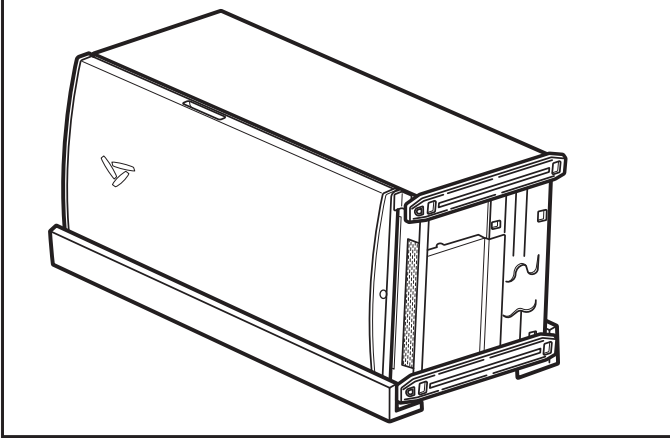

Replace the foam corner post on the non-hinged side, and then place the unit on its side on top of cardboard or other protective material. Make sure the door hinge is facing upward.

IMPORTANT: It is important that the door hinge face upward during the entire caster installation to make sure the door will not swing open during installation.

NOTE: If foam corner posts have been discarded, 2" x 4" boards may be used.

2. Remove Skid Bolts

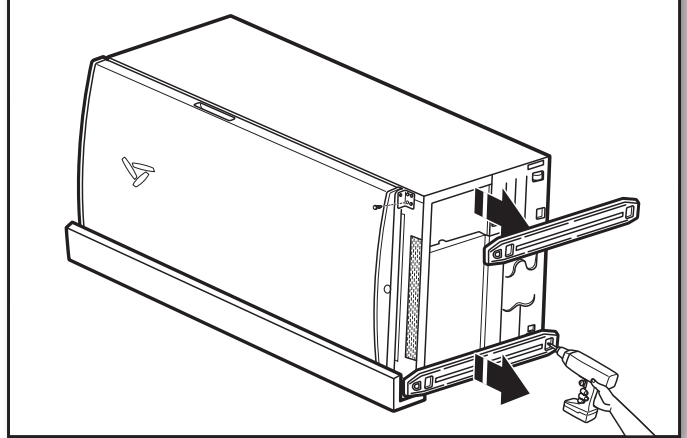

Using a 5/16" nut driver, remove the four skid bolts (two on each side) from the lower front and rear of the unit. Remove the skids.

3. Remove Rear Screws

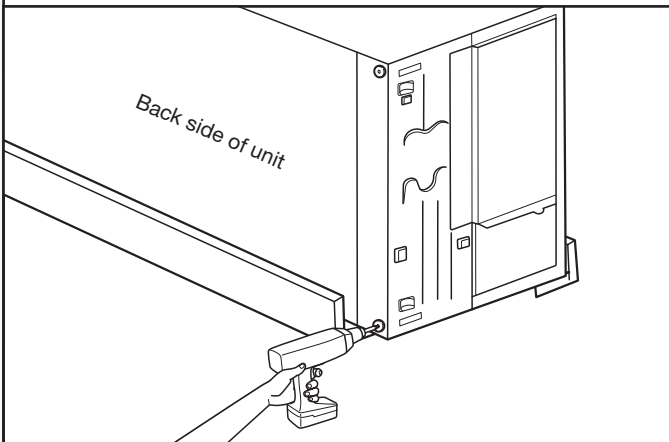

Break off the corners of the foam corner posts to gain access to the large caster bracket screws on the left and right rear of the unit. Remove the two rear caster bracket screws with a TORX T40 screwdriver.

4. Remove Upper And Lower Hex-Head Bracket Screws

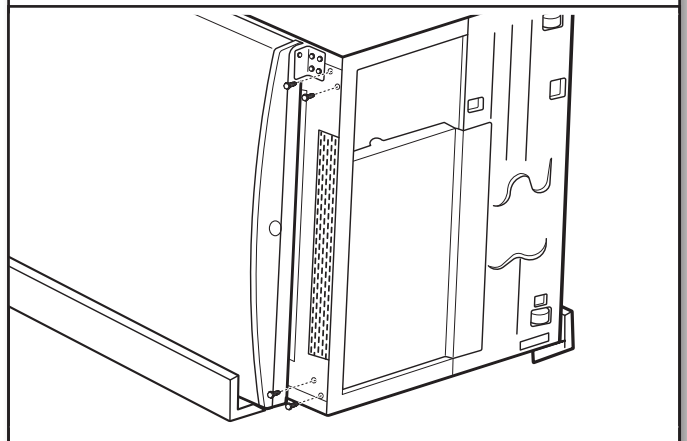

Remove the four 3/8" upper and lower hex-head bracket screws with a TORX T25 screwdriver or 3/8" nut driver.

5. Install Caster Brackets

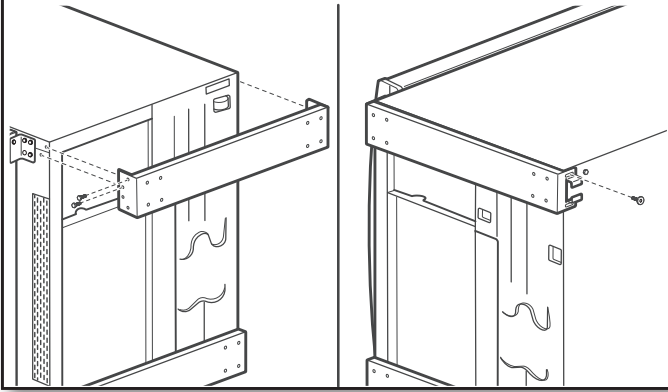

Align the right-hand caster brackets and drive in the rear bracket screws with the TORX T40 screwdriver from step 3. Pushing the brackets against the bottom of the refrigerator or freezer, reinstall the upper and lower hex-head bolts with a TORX T25 screwdriver or a 3/8" nut driver. Repeat on the left-hand side.

6. Attach Casters

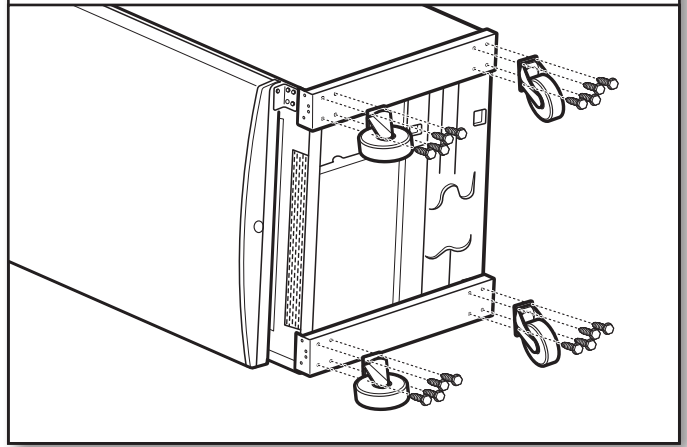

Align a front caster (with a brake) with the holes in the caster bracket. Make sure that the brake faces the outside of the product. Insert and hand-tighten 1/2" caster bolts into each of the four caster bracket holes. Once all four caster bolts are installed, tighten the bolts with a 1/2" wrench or ratchet with an extender. Repeat installation with the other front caster (brake) and the two rear casters (no brake).

Helpful Tip: Rotate the caster to gain access to bolt locations.

7. Lock Front Casters

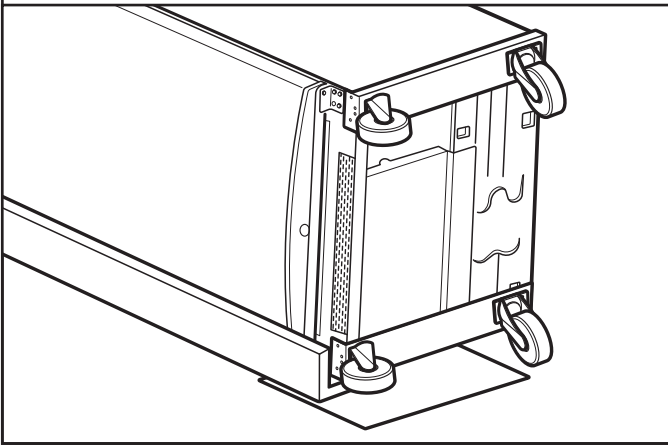

Lock the front casters and insert a small piece of cardboard between the caster brake and the floor. This will help prevent the brake from rubbing on the floor.

NOTE: Locking the casters will help prevent the refrigerator or freezer from moving while it is being lifted.

8. Stand Unit Upright

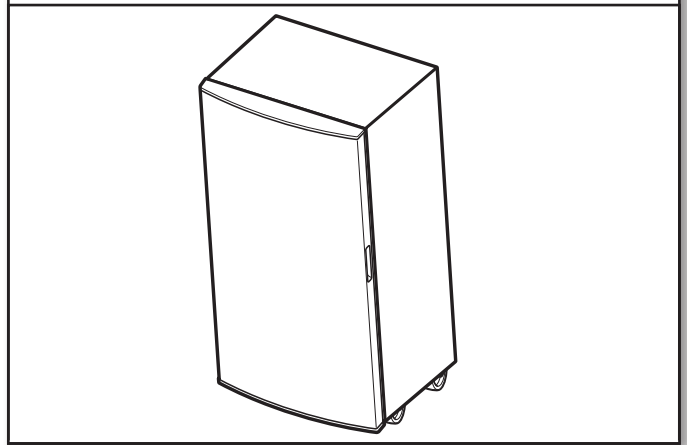

Stand the refrigerator or freezer upright.

9. Prepare For Foot Pedal Installation

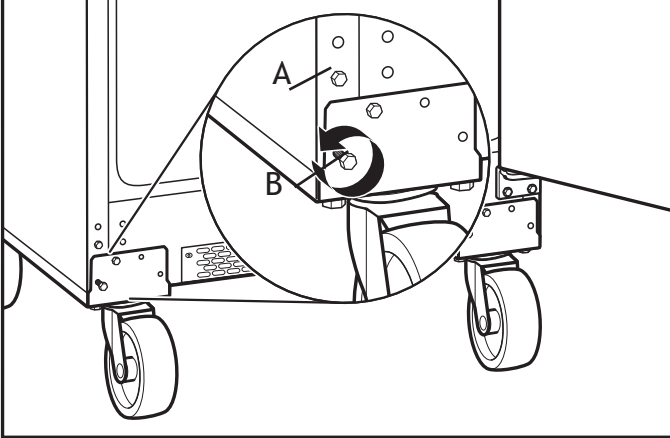

Open the product door for easier access to the foot pedal area. On both sides of the product, loosen the lower 3/8" hex-head bracket screw (B), exposing 1/4" of the thread, and fully withdraw the upper 3/8" hex-head foot pedal screw (A).

10. Align And Hang Foot Pedal

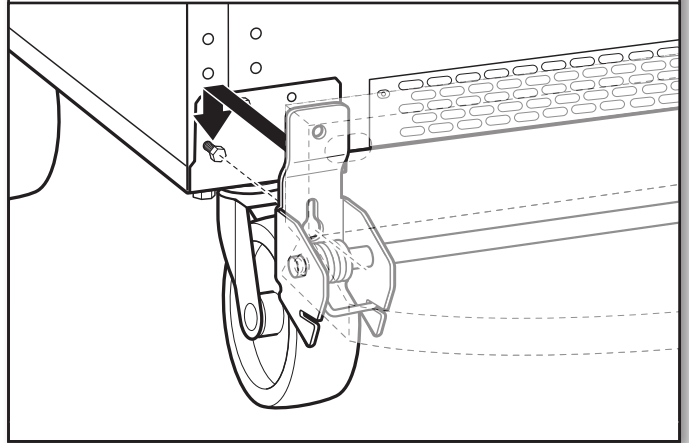

Align the circular parts of the foot pedal keyholes with the lower 3/8" hex-head bracket screws. Hang the pedal on the lower bracket screws. If the keyhole does not fully engage, loosen the bolt until engaged.

11. Reinstall The Foot Pedal Bolt

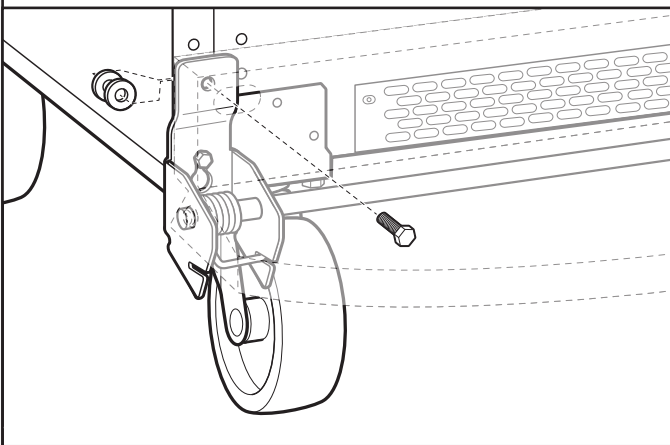

On the door hinge side, use a TORX T25 screwdriver or a 3/8" nut driver to feed the screw through the pedal bracket mounting hole and tighten to the cabinet.

On the non-hinged side, use a TORX T25 screwdriver or a 3/8" nut driver to feed the screw through the pedal bracket mounting hole and two spacers provided, and tighten to the cabinet.

Helpful Tip: If you are having trouble attaching the two spacers between the bracket and cabinet, tape the spacer to the back of the pedal bracket mounting hole with a strip of transparent tape before adding the screws.

Tighten the second screw with a 3/8" wrench or 3/8" Ratchet wrench.

12. Adjust Actuator Screw If Desired

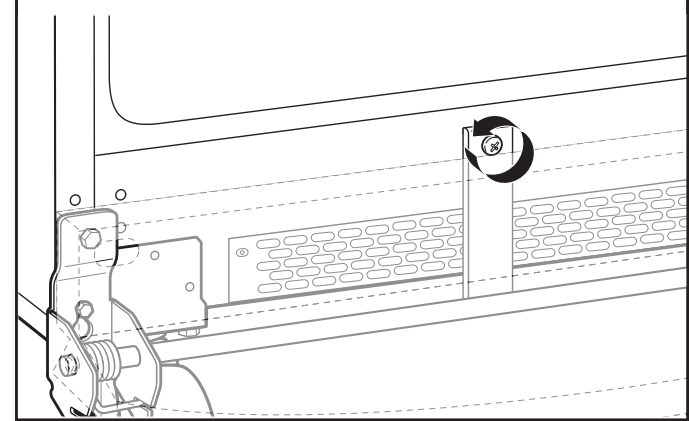

Use a Phillips screwdriver to make adjustments to the foot pedal actuator screw to adjust the foot pedal to your liking.

13. Place Unit In Final Location

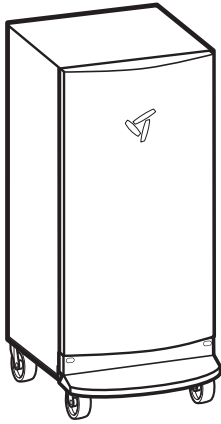

⚠ WARNING



Electrical Shock Hazard

Plug into a grounded 3 prong outlet.

Do not remove ground prong.

Do not use an adapter.

Do not use an extension cord.

Failure to follow these instructions can result in death, fire, or electrical shock.

Unlock the casters, roll the unit into the final position, and relock the casters. Plug the refrigerator or freezer into a 3 prong outlet.

NOTE: If installing your refrigerator or freezer on an unlevel floor, shims may be required to prevent the unit from rolling.

OPERATING YOUR REFRIGERATOR OR FREEZER

Normal Sounds

Your new refrigerator or freezer may make sounds that your old one did not make. You might be concerned about these sounds because they are new to you. Most of the new sounds are normal. Hard surfaces, like the floor, walls, and cabinets can make the sounds seem louder. The following describes the kinds of sounds and what may be making them.

- Your unit is designed to run more efficiently to keep your food items at the desired temperatures and to minimize energy usage. The high-efficiency compressor and fans may cause your unit to run longer than your old one. You may also hear a pulsating or high-pitched sound from the compressor or fans as they adjust to optimize performance.
- You may hear the evaporator fan motor circulating air through the refrigerator or freezer compartment. The fan speed may increase as you open the doors or add warm food.
- Rattling noises may come from the flow of refrigerant or items stored on top of the unit.
- Water dripping on the defrost heater during a defrost cycle may cause a sizzling sound.
- As each cycle ends, you may hear a gurgling sound due to the refrigerant flowing in your unit.
- Contraction and expansion of the inside walls may cause a popping noise.
- You may hear air being forced over the condenser by the condenser fan.
- You may hear water running into the drain pan during the defrost cycle.

Ensuring Proper Air Circulation

In order to ensure proper temperature, you need to permit proper airflow in the refrigerator or freezer. As shown in the illustration, cool air enters from the unit wall and moves down. The air then recirculates through the vent near the bottom.

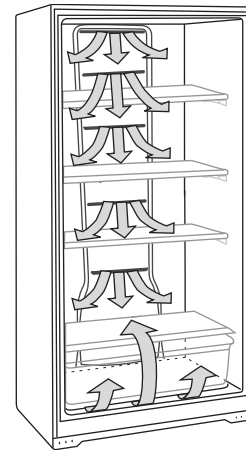

Do not block any of these vents with food packages. If the vents are blocked, airflow will be restricted, and temperature and moisture problems may occur.

IMPORTANT: To avoid odor transfer and drying out of food, wrap or cover foods tightly.

Using the Refrigerator Control

The temperature control is located at the top front of the refrigerator compartment.

Temperature Control

When you first install your refrigerator, check that the control is set to the temperature that is desired for your food items.

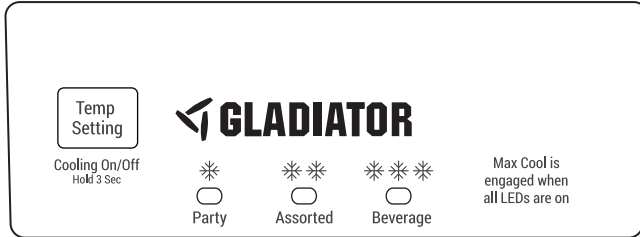

There are three pre-set temperature buttons to choose from on your refrigerator:

- **Party:** Sets refrigerator temperature at a level suitable for temporary loading of party platters or cold appetizers.
- **Assorted:** Multi-purpose setting accommodates a variety of refrigerated items.
- **Beverage:** Holds refrigerator at a lower temperature to keep beverages extra cold.

IMPORTANT:

- The Assorted setting is designed to maintain the temperature at or near 37°F (3°C) under normal operating conditions.
- Wait 24 hours before you put food into the refrigerator. If you add food before the refrigerator has cooled completely, your food may spoil.
NOTE: Adjusting the temperature set point to a colder than recommended setting will not cool the refrigerator any faster.
- If the temperature is too warm or too cold in the refrigerator, first check the air vents to be sure they are not blocked before adjusting the control.
- The control is set correctly when milk or juice is as cold as you like, but the Assorted setting should be correct for normal household usage.
- When the refrigerator is first started, the compressor will run constantly until the refrigerator is cooled. It may take up to 6 or 8 hours (or longer), depending on room temperature and the number of times the refrigerator door is opened. After the refrigerator is cooled, the compressor will turn on and off as needed to keep the refrigerator at the proper temperature.
- The outside of your refrigerator may feel warm. This is normal. The refrigerator's design and main function is to remove heat from packages and air space inside the refrigerator. The heat is transferred to the room air, making the outside of the refrigerator feel warm.

Adjusting Control

If you need to adjust the temperature in the refrigerator compartment, press TEMP SETTING to display the desired temperature setting. Choose from Party, Assorted, or Beverage.

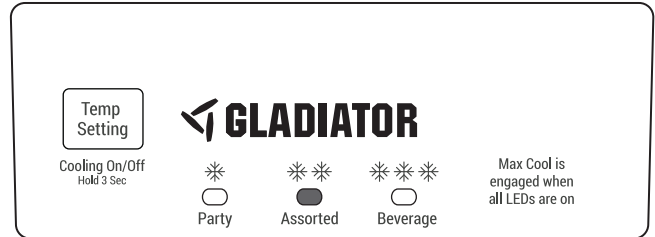

NOTE: When adjusting the control to a different setting, wait 24 hours between adjustments for the temperature to stabilize.

Cooling On/Off

Your refrigerator will not cool when cooling is turned off.

To turn cooling off, press and hold TEMP SETTING for 3 seconds. In the Off position, none of the lights on the control panel will be illuminated. The main refrigerator light bulb will still operate.

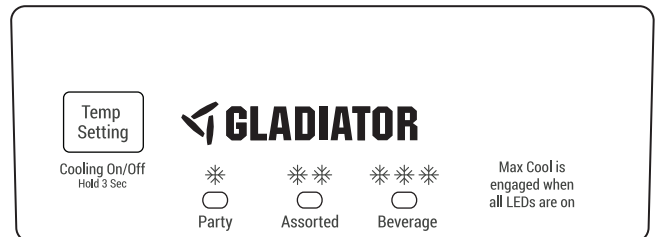

To turn cooling on, press and hold TEMP SETTING for 3 seconds. When cooling is on, the control panel lights will be illuminated.

Max Cool

Use this feature to assist with periods of high refrigerator use, such as full grocery loads or temporarily warm room temperature.

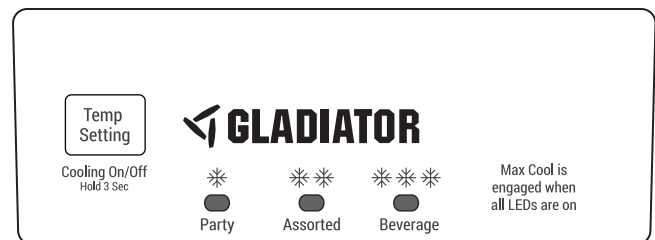

To activate Max Cool, press TEMP SETTING until all the snowflake icons are illuminated simultaneously.

The refrigerator will remain in the Max Cool setting for 24 hours after the extra-low temperature is reached. Once the time has expired, the refrigerator will return to the previous temperature setting. Max Cool may be manually turned off by pressing Temp Setting to select the desired temperature setting from the snowflake on the left (least cold) to the snowflake on the right (coldest).

Using the Freezer Control

The temperature control is located at the top front of the freezer compartment.

Temperature Control

When you first install your refrigerator, check that the control is set to the temperature that is desired for your food items.

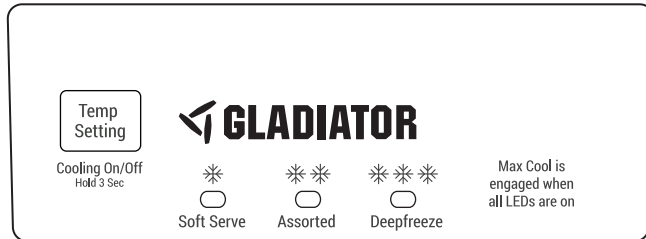

There are three pre-set temperature buttons to choose from on your freezer:

- **Soft Serve:** Raises freezer temperature slightly to create optimal conditions for serving ice cream.
- **Assorted:** Multi-purpose setting accommodates a variety of frozen items.
- **DeepFreeze:** Lowers freezer temperature for longer-term storage of frozen items.

IMPORTANT:

- The Assorted setting is designed to maintain the temperature at or near 0°F (-18°C) under normal operating conditions.
- Wait 24 hours before you put food into the freezer. If you add food before the freezer has cooled completely, your food may spoil.

NOTE: Adjusting the temperature set point to a colder than recommended setting will not cool the freezer any faster.

- If the temperature is too warm or too cold in the freezer, first check the air vents to be sure they are not blocked before adjusting the control.
- The Assorted setting should be correct for normal household usage. The control is set correctly when ice cream is firm.
- When the freezer is first started, the compressor will run constantly until the freezer is cooled. It may take up to 6 or 8 hours (or longer), depending on room temperature and the number of times the freezer door is opened. After the freezer is cooled, the compressor will turn on and off as needed to keep the freezer at the proper temperature.
- The outside of your freezer may feel warm. This is normal. The freezer's design and main function is to remove heat from packages and air space inside the freezer. The heat is transferred to the room air, making the outside of the freezer feel warm.

Adjusting Control

If you need to adjust the temperature in the freezer compartment, press TEMP SETTING to display the desired temperature setting. Choose from Soft Serve, Assorted, and Deepfreeze.

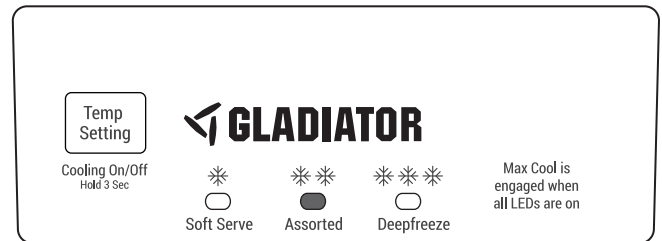

NOTE: When adjusting the control to a different setting, wait 24 hours between adjustments for the temperature to stabilize.

Cooling On/Off

Your freezer will not cool when cooling is turned off.

To turn cooling off, press and hold TEMP SETTING for 3 seconds. In the Off position, none of the lights on the control panel will be illuminated. The main freezer light bulb will still operate.

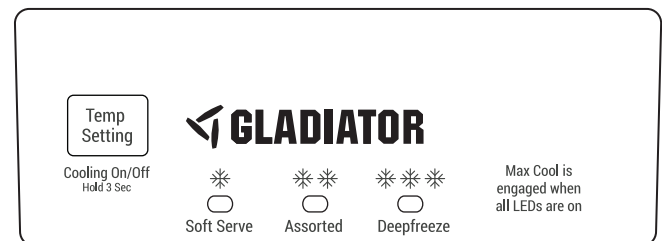

To turn cooling on, press and hold TEMP SETTING for 3 seconds. When cooling is on, the control panel lights will be illuminated.

Max Cool

Use this feature to assist with periods of high freezer use, such as full grocery loads or temporarily warm room temperature.

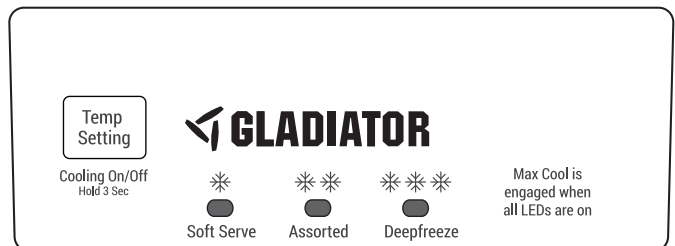

To activate Max Cool, press TEMP SETTING until all the snowflake icons are illuminated simultaneously.

The freezer will remain in the Max Cool setting for 24 hours after the extra-low temperature is reached. Once the time has expired, the freezer will return to the previous temperature setting. Max Cool may be manually turned off by pressing Temp Setting to select the desired temperature setting from the snowflake on the left (least cold) to the snowflake on the right (coldest).

CARING FOR YOUR REFRIGERATOR OR FREEZER

Registering Your Unit

There are many benefits of registering your product. Find out more and register your product online at www.gladiatorgarageworks.com. Consumers in Canada can call: 1-800-807-6777. Your product's model and serial numbers can be located on the serial sticker inside your unit.

Refrigerator and Freezer Features

Refrigerator and Freezer Shelves

The refrigerator will come with two deep, extra-thick glass shelves and one shallow solid metal shelf. Your freezer will come with two deep, heavy gauge wire shelves and one shallow heavy gauge wire shelf.

Store similar foods together and adjust the shelves to fit different heights. This reduces the time the refrigerator door is open and saves energy.

To Remove and Replace a Shelf:

1. Remove the shelf by lifting straight up, and pulling the shelf out.
2. Replace the shelf by lowering the shelf onto the supports on the side walls.

Half-Width and Full-Width Gallon Door Bins

To Remove and Replace a Bin:

1. Remove the bin by tipping the front of the bin forward and sliding out.
2. Replace the bin by sliding it in above the desired support, and then tilting it back into place.

Heavy Gauge Wire Baskets

The slide-out basket provides separate storage space for items that are difficult to store on freezer shelves. To remove the basket, pull out and lift up.

To Remove and Replace the Basket:

1. Remove the basket by tipping the front of the basket forward and sliding out.
2. Replace the basket by sliding it in above the desired support, and then tilting it back into place.

Pizza Zone (Freezer only)

To Remove and Replace the Gate:

1. Remove the gate by lifting the top of the gate up and out of the supports.
2. Replace the gate to original position by lowering it into the supports.

Silver Tread Door Bin (Refrigerator only)

To Remove and Replace the Bin:

1. Remove the bin by lifting the top of the gate up and out of the supports.
2. Replace the bin to original position by lowering it into the supports.

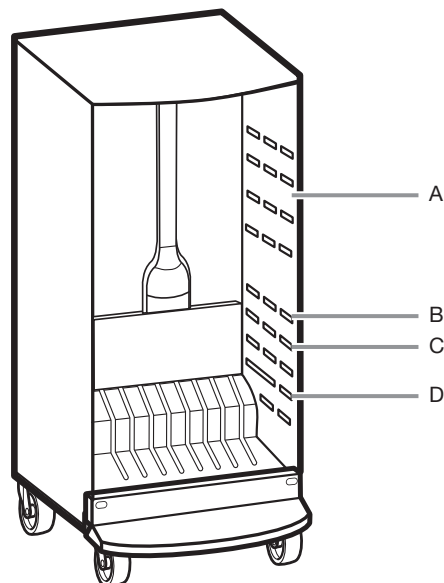

- A. Deep extra thick glass or deep heavy gauge wire shelves
B. Shallow solid metal shelf or shallow heavy gauge wire shelf
C. Short heavy gauge wire basket
D. Tall heavy gauge wire basket

Accessories

These units do not accept an ice maker kit. The Following accessories are available for your refrigerator or freezer. To order an accessory, contact us and ask for the part number.

In the U.S.A, call 1-866-342-4089

In Canada, call 1-800-807-6777

Extra Deep Shelf for Freezer: W11187306

Extra Deep Shelf for Refrigerator: W11187309

Affresh® Kitchen & Appliance Cleaner:

In U.S.A., order Part #W10355010

In Canada, order Part #W10355010B

Cleaning Your Refrigerator or Auto-Defrosting Freezer

⚠ WARNING



Explosion Hazard

Use nonflammable cleaner.

Failure to do so can result in death, explosion, or fire.

Clean the refrigerator or freezer about once a month to keep odors from building up. Wipe up spills immediately.

To Clean Your Refrigerator or Freezer:

1. Press and hold TEMP SETTING for 3 seconds to turn off cooling.

† Affresh® is a registered trademark of Whirlpool.

2. Unplug the refrigerator or freezer or disconnect power.
3. Remove all removable parts from inside, such as shelves, crispers, etc.
4. Hand wash, rinse, and dry removable parts and interior surfaces thoroughly. Use a clean sponge or soft cloth and a mild detergent in warm water.
 - Do not use abrasive or harsh cleaners such as window sprays, scouring cleansers, flammable fluids, cleaning waxes, concentrated detergents, bleaches, or cleansers containing petroleum products on plastic parts, interior and door liners or gaskets. Do not use paper towels, scouring pads, or other harsh cleaning tools. These can scratch or damage materials.
 - To help remove odors, you can wash interior walls with a mixture of warm water and baking soda (2 tbs to 1 qt [26 g to 0.95 L] of water).
5. Replace removable parts.
6. Use the appropriate cleaning method for your exterior finish.

Painted Metal: Wash exterior door with a microfiber cloth and a mild detergent in warm water. For all other exterior surfaces, wash with a clean sponge or soft cloth and a mild detergent in warm water. Do not use abrasive or harsh cleaners or cleaners designed for stainless steel. Dry thoroughly with a soft cloth.

7. Clean the condenser coils regularly. Coils may need to be cleaned as often as every other month. This may help save energy.
 - Open the refrigerator or freezer door and remove the base grille by removing two Phillips head screws and pulling the grille toward you.
 - Use a vacuum with an extended attachment to clean the condenser coils when they are dusty or dirty.
 - Replace the base grille by aligning the ends of the grille with the leveling assemblies on each side and snapping the grille into place. Reinstall the screws.
8. Plug in the refrigerator or freezer or reconnect the power.
9. Set the temperature control to desired setting. See the “Using the Controls” sections.

Auto Defrost Freezer

Auto-defrost means that you will not have to defrost your freezer. Frost is removed by air moving and collecting any moisture and depositing it on the cooling coil. The cooling coil periodically warms up enough to melt the frost, and it then flows down to the drain pan (located behind the base grille) where it is evaporated.

Changing the Light Bulb(s)

IMPORTANT: The lighting system in this appliance may consist of:

- Sealed LED modules
- LED Bulbs
- Incandescent Bulbs

Sealed LED module is an LED which does not need to be replaced. If a Sealed LED module(s) do not illuminate when the refrigerator and/or freezer door is opened, call for assistance or service. See “Warranty” for contact information.

If a LED Bulb does not illuminate when the refrigerator and/or freezer door is opened, replace with like bulb following this procedure:

1. Unplug the appliance or disconnect power.
2. Remove the light shield.
 - Remove the hardware holding the light shield in place.
 - Top of the appliance compartment - Slide the light shield toward the back of the compartment to release it from the light assembly.
3. Replace the burned-out bulb(s) with a LED bulb of the same size, shape and wattage.
 - Order Part Number W10805744 (3.6 W).

NOTE: Some LED replacement bulbs are not recommended for wet/damp environments. The refrigerator and freezer compartments are considered to be wet/damp environments. If using a brand of LED bulb other than the recommended LED bulb, before installation, read and follow all instructions on the LED packaging.

4. Replace the light shield by inserting the tabs on the shield into the liner holes on each side of the light assembly. Slide the shield toward the front until it locks into place.

NOTE: To avoid damaging the light shield, do not force the shield beyond the locking Point.

5. Replace the hardware that holds the shield in place.
6. Plug in the appliance or reconnect power.

If an incandescent bulb does not illuminate when the refrigerator and/or freezer door is opened, replace with like bulb using the same procedure outlined above. Replace burned out bulb with only incandescent bulb(s) of the same size, shape and wattage (maximum 40 W) designed for household appliances.

Power Interruptions

If the power will be out for 24 hours or less, keep the door closed to help food stay cold and frozen.

If the power will be out for more than 24 hours, consume or can perishable food at once.

REMEMBER: If the condition of the food is poor, dispose of it.

Vacation and Moving Care

Vacations

If you choose to leave the refrigerator or freezer on while you're away, use up any perishables and freeze other items.

If you choose to turn the refrigerator or freezer off before you leave, follow these steps:

1. Remove all food from the refrigerator or freezer.
2. Turn the control to the off position. See the “Using the Controls” section.
3. Clean the refrigerator or freezer, wipe it, and dry well.
4. Tape rubber or wood blocks to the tops of both doors to prop them open far enough for air to get in. This stops odor and mold from building up.

Moving

When you are moving your refrigerator or freezer to a new home, follow these steps to prepare it for the move.

1. Remove all food from the refrigerator or freezer.
2. Turn the control to the off position. See the “Using the Controls” section.
3. Unplug the refrigerator or freezer.
4. Empty water from the defrost pan.
5. Clean, wipe, and dry thoroughly.
6. Take out all removable parts, wrap them well, and tape them together so they don't shift and rattle during the move.
7. Tape the doors shut and tape the power cord to the unit cabinet.
8. Unlock the casters to roll away the unit.

When you get to your new home, put everything back and refer to the “Installing Your Refrigerator or Freezer” section for preparation instructions.

TROUBLESHOOTING

First try the solutions suggested here. If you need further assistance or more recommendations that may help you avoid a service call, refer to the warranty page in this manual, or visit www.whirlpool.com/product_help for recommendations that may help you avoid a service call. In Canada, visit <http://www.whirlpool.ca>.

Contact us by mail with any questions or concerns at the address below:

In the U.S.A.:

Whirlpool Brand Home Appliances
Customer eXperience Center
553 Benson Road
Benton Harbor, MI 49022-2692

In Canada:

Whirlpool Brand Home Appliances
Customer eXperience Centre
200 – 6750 Century Ave.
Mississauga ON L5N 0B7

Please include a daytime phone number in your correspondence.

Refrigerator Operation

⚠ WARNING



Electrical Shock Hazard

Plug into a grounded 3 prong outlet.

Do not remove ground prong.

Do not use an adapter.

Do not use an extension cord.

Failure to follow these instructions can result in death, fire, or electrical shock.

⚠ WARNING



Explosion Hazard

Use nonflammable cleaner.

Failure to do so can result in death, explosion, or fire.

PROBLEM	RECOMMENDED SOLUTIONS
Refrigerator Will Not Operate	Check that it is plugged into a grounded 3 prong outlet. Check that the temperature control is turned on. Check that the refrigerator is not running an automatic defrost cycle. Replace the fuse or reset the circuit breaker. NOTE: If problems continue, contact an electrician.
Lights Do Not Work	Check that it is plugged into a grounded 3 prong outlet. Check that the light bulb is tight in the socket and is not burned out.
Water in Defrost Drain Pan	It is normal for water to drip into the defrost drain pan when refrigerator is defrosting. When humidity is high, it is normal for water in the defrost pan to take longer to evaporate.
Motor Seems to Run Too Much	Check that the door closes properly. Adding a large amount of food warms the refrigerator, causing the unit to run longer to cool back down. If this is the situation, wait approximately 6 to 8 hours to allow the refrigerator to reach the correct temperature. Get all needed items out at one time, keep food organized, and close the door as soon as possible. Check that the condenser coils are clean. Check that space around refrigerator meets air circulation requirements. See the “Location Requirements” section. Warmer than normal room temperature will cause the motor to run longer. NOTE: If none of the above is true, your new refrigerator will run longer than your old one due to its high-efficiency motor.
Temperature is Too Warm	Check that air vents are clear. See the “Ensuring Proper Air Circulation” section for air vent locations. Get all needed items out at one time, keep food organized, and close the door as soon as possible. Adding a large amount of food warms the refrigerator, causing the refrigerator to run longer to cool back down. Check that the temperature control is set correctly for surrounding conditions.
The Door Will Not Close Completely or Is Difficult To Open	Check that there are no food packages blocking the door. On some models, check that the crisper covers, pans, shelves, bins, and baskets are in the correct position. Check that gaskets are clean. See the “Caring for Your Refrigerator or Freezer” section. Check that the refrigerator is stable.
Noisy	The sounds may be normal. See the “Normal Sounds” section.
Refrigerator Makes Loud Buzzing/Clicking Sound	Adding a large amount of food warms the refrigerator. It can take several hours for the refrigerator to return to normal temperature.

Freezer Operation

⚠️ WARNING



Electrical Shock Hazard

Plug into a grounded 3 prong outlet.
Do not remove ground prong.
Do not use an adapter.
Do not use an extension cord.
Failure to follow these instructions can result in death, fire, or electrical shock.

⚠️ WARNING



Explosion Hazard

Use nonflammable cleaner.
Failure to do so can result in death, explosion, or fire.

PROBLEM	RECOMMENDED SOLUTIONS
Freezer Will Not Operate	Check that it is plugged into a grounded 3 prong outlet. Check that the temperature control is turned on. Check that the freezer is not running an Automatic Defrost cycle. Replace the fuse or reset the circuit breaker. NOTE: If problems continue, contact an electrician.
Lights Do Not Work	Check that it is plugged into a grounded 3 prong outlet. Check that the light bulb is tight in the socket and is not burned out.
Water in Defrost Drain Pan	It is normal for water to drip into the defrost drain pan when the freezer is defrosting. When humidity is high, it is normal for water in the defrost pan to take longer to evaporate.
Motor Seems to Run Too Much	Check that the door closes properly. Defrost and clean the freezer to remove excessive frost. Adding a large amount of food warms the freezer, causing the freezer to run longer to cool back down. If this is the situation, wait approximately 6 to 8 hours to allow the freezer to reach the correct temperature. Get all needed items out at one time, keep food organized, and close the door as soon as possible. Check that the condenser coils are clean. Check that the door gasket is sealed all the way around. If not, contact a qualified technician. Check that space around freezer meets air circulation requirements. See the "Location Requirements" section. NOTE: If none of the above is true, your new freezer will run longer than your old one due to its high-efficiency motor.
Temperature Is Too Warm	Check that air vents are clear. See the "Ensuring Proper Air Circulation" section for air vent locations. Get all needed items out at one time, keep food organized, and close the door as soon as possible. Adding a large amount of food warms the freezer, causing the freezer to run longer to cool back down. Check that the temperature control is set correctly for surrounding conditions.
The Door Will Not Close Completely or Is Difficult to Open	Check that there are no food packages blocking the door. On some models, check that the shelves and baskets are in the correct position. Check that gaskets are clean. See the "Caring for Your Refrigerator or Freezer" section. Check that the freezer is stable.
Freezer Makes Loud Buzzing/ Clicking Sound	Adding a large amount of food warms the freezer. It can take several hours for the freezer to return to normal temperature.

GLADIATOR® MAJOR APPLIANCE LIMITED WARRANTY

ATTACH YOUR RECEIPT HERE. PROOF OF PURCHASE IS REQUIRED TO OBTAIN WARRANTY SERVICE.

Please have the following information available when you call the Customer eXperience Center:

- Name, address, and telephone number
- Model number and serial number
- A clear, detailed description of the problem
- Proof of purchase, including dealer or retailer name and address

IF YOU NEED SERVICE:

1. Before contacting us to arrange service, please determine whether your product requires repair. Some questions can be addressed without service. Please take a few minutes to review the Troubleshooting section of the Use and Care Guide or visit gladiatorgarageworks.com.
2. All warranty service is provided exclusively by our authorized Gladiator Service Providers. In the U.S. and Canada, direct all requests for warranty service to:

Gladiator Customer eXperience Center

In the U.S.A., call 1-800-253-1301. In Canada, call 1-800-807-6777.

If outside the 50 United States or Canada, contact your authorized Gladiator dealer to determine whether another warranty applies.

ONE YEAR LIMITED WARRANTY

WHAT IS COVERED

For one year from the date of purchase, when this major appliance is installed, operated, and maintained according to instructions attached to or furnished with the product, Whirlpool Corporation or Whirlpool Canada LP (hereafter "Gladiator") will pay for factory specified replacement parts and repair labor to correct defects in materials or workmanship that existed when this major appliance was purchased or, at its sole discretion, replace the product. In the event of product replacement, your appliance will be warranted for the remaining term of the original unit's warranty period.

YOUR SOLE AND EXCLUSIVE REMEDY UNDER THIS LIMITED WARRANTY SHALL BE PRODUCT REPAIR AS PROVIDED HEREIN. Service must be provided by a Gladiator designated service company. This limited warranty is valid only in the United States or Canada and applies only when the major appliance is used in the country in which it was purchased. This limited warranty is effective from the date of original consumer purchase. Proof of original purchase date is required to obtain service under this limited warranty.

WHAT IS NOT COVERED

1. Commercial, non-residential, multiple-family use, or use inconsistent with published user, operator, or installation instructions.
2. In-home instruction on how to use your product.
3. Service to correct improper product maintenance or installation, installation not in accordance with electrical or plumbing codes, or correction of household electrical or plumbing (e.g., house wiring, fuses, or water inlet hoses).
4. Consumable parts (e.g., light bulbs, batteries, air or water filters, preservation solutions).
5. Defects or damage caused by the use of non-genuine Gladiator parts or accessories.
6. Conversion of products from natural gas or propane gas.
7. Damage from accident, misuse, abuse, fire, floods, acts of God, or use with products not approved by Gladiator.
8. Repairs to parts or systems to correct product damage or defects caused by unauthorized service, alteration, or modification of the appliance.
9. Cosmetic damage including scratches, dents, chips, and other damage to the appliance finishes, unless such damage results from defects in materials and workmanship and is reported to Gladiator within 30 days.
10. Discoloration, rust, or oxidation of surfaces resulting from caustic or corrosive environments including, but not limited to, high salt concentrations, high moisture or humidity, or exposure to chemicals.
11. Food or medicine loss due to product failure.
12. Pickup or delivery. This product is intended for in-home repair.
13. Travel or transportation expenses for service in remote locations where an authorized Gladiator servicer is not available.
14. Removal or reinstallation of inaccessible appliances or built-in fixtures (e.g., trim, decorative panels, flooring, cabinetry, islands, countertops, drywall) that interfere with servicing, removal, or replacement of the product.
15. Service or parts for appliances with original model/serial numbers removed, altered, or not easily determined.

The cost of repair or replacement under these excluded circumstances shall be borne by the customer.

DISCLAIMER OF IMPLIED WARRANTIES

IMPLIED WARRANTIES, INCLUDING ANY IMPLIED WARRANTY OF MERCHANTABILITY OR IMPLIED WARRANTY OF FITNESS FOR A PARTICULAR PURPOSE, ARE LIMITED TO ONE YEAR OR THE SHORTEST PERIOD ALLOWED BY LAW. Some states and provinces do not allow limitations on the duration of implied warranties of merchantability or fitness, so this limitation may not apply to you. This warranty gives you specific legal rights, and you also may have other rights that vary from state to state or province to province.

DISCLAIMER OF REPRESENTATIONS OUTSIDE OF WARRANTY

Gladiator makes no representations about the quality, durability, or need for service or repair of this major appliance other than the representations contained in this warranty. If you want a longer or more comprehensive warranty than the limited warranty that comes with this major appliance, you should ask Gladiator or your retailer about buying an extended warranty.

LIMITATION OF REMEDIES: EXCLUSION OF INCIDENTAL AND CONSEQUENTIAL DAMAGES

YOUR SOLE AND EXCLUSIVE REMEDY UNDER THIS LIMITED WARRANTY SHALL BE PRODUCT REPAIR AS PROVIDED HEREIN. GLADIATOR SHALL NOT BE LIABLE FOR INCIDENTAL OR CONSEQUENTIAL DAMAGES. Some states and provinces do not allow the exclusion or limitation of incidental or consequential damages, so these limitations and exclusions may not apply to you. This warranty gives you specific legal rights, and you also may have other rights that vary from state to state or province to province.

