

DRYER INSTALLATION INSTRUCTIONS

乾衣機安裝說明

Table of Contents

DRYER SAFETY	2
INSTALLATION REQUIREMENTS.....	4
Tools and Parts	4
LOCATION REQUIREMENTS.....	5
GAS DRYER POWER HOOKUP	7
INSTALL LEVELING LEGS.....	9
MAKE GAS CONNECTION.....	10
VENTING.....	11
Venting Requirements	11
Plan Vent System	12
Install Vent System.....	13
CONNECT INLET HOSE	14
CONNECT VENT	15
LEVEL DRYER	16
COMPLETE INSTALLATION CHECKLIST.....	16
DOOR REVERSAL (OPTIONAL).....	17

目錄

乾衣機安全.....	23
安裝要求	25
工具與零件	25
地點要求	26
瓦斯型乾衣機電源連接.....	28
安裝水平支腳.....	30
進行瓦斯連接	31
排氣	32
排氣要求.....	32
設計排氣系統	33
安裝排氣系統	34
連接進水管（僅蒸氣機種）	35
連接排氣管.....	36
放平乾衣機.....	37
完成安裝檢核清單.....	37
把門裝至另一邊（選項）	38

INSTALLATION NOTES / 安裝備註

Date of purchase / 購買日期: _____

Date of installation / 安裝日期: _____

Installer / 安裝人員: _____

Model number / 型號: _____

Serial number / 序號: _____

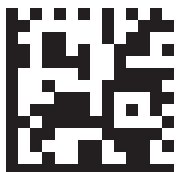

DRYER SAFETY

Your safety and the safety of others are very important.

We have provided many important safety messages in this manual and on your appliance. Always read and obey all safety messages.



This is the safety alert symbol.

This symbol alerts you to potential hazards that can kill or hurt you and others.

All safety messages will follow the safety alert symbol and either the word “DANGER” or “WARNING.”

These words mean:

 **DANGER**

You can be killed or seriously injured if you don't immediately follow instructions.

 **WARNING**

You can be killed or seriously injured if you don't follow instructions.

All safety messages will tell you what the potential hazard is, tell you how to reduce the chance of injury, and tell you what can happen if the instructions are not followed.



WARNING - “Risk of Fire”

- Clothes dryer installation must be performed by a qualified installer.
- Install the clothes dryer according to the manufacturer's instructions and local codes.
- Do not install a clothes dryer with flexible plastic venting materials or flexible metal (foil type) duct. If flexible metal duct is installed, it must be of a specific type identified by the appliance manufacturer as suitable for use with clothes dryers. Flexible venting materials are known to collapse, be easily crushed, and trap lint. These conditions will obstruct clothes dryer airflow and increase the risk of fire.
- To reduce the risk of severe injury or death, follow all installation instructions.
- Save these instructions.

WARNING

Fire Hazard

Failure to follow safety warnings exactly could result in serious injury, death, or property damage.

Do not install a booster fan in the exhaust duct.

Install all clothes dryers in accordance with the installation instructions of the manufacturer of the dryer.

DRYER SAFETY

 **WARNING:**

FIRE OR EXPLOSION HAZARD

Failure to follow safety warnings exactly could result in serious injury, death or property damage.

- Do not store or use gasoline or other flammable vapors and liquids in the vicinity of this or any other appliance.
- **WHAT TO DO IF YOU SMELL GAS:**
 - Do not try to light any appliance.
 - Do not touch any electrical switch; do not use any phone in your building.
 - Clear the room, building, or area of all occupants.
 - Immediately call your gas supplier from a neighbor's phone. Follow the gas supplier's instructions.
 - If you cannot reach your gas supplier, call the fire department.
- Installation and service must be performed by a qualified installer, service agency, or the gas supplier.

WARNING: Gas leaks cannot always be detected by smell.

Gas suppliers recommend that you use a gas detector approved by UL or CSA.

For more information, contact your gas supplier.

If a gas leak is detected, follow the "What to do if you smell gas" instructions.

IMPORTANT: The gas installation must conform with local codes, or in the absence of local codes, with the National Fuel Gas Code, ANSI Z223.1/NFPA 54, or the Natural Gas and Propane Installation Code, CSA B149.1.

The dryer must be electrically grounded in accordance with local codes, or in the absence of local codes, with the National Electrical Code, ANSI/NFPA 70, or the Canadian Electrical Code, Part 1, CSA C22.1.

In the State of Massachusetts, the following installation instructions apply:

- Installations and repairs must be performed by a qualified or licensed contractor, plumber, or gas fitter qualified or licensed by the State of Massachusetts.
- Acceptable Shut-off Devices: Gas Cocks and Ball Valves installed for use shall be listed.
- A flexible gas connector, when used, must not exceed 4 feet (121.9 cm).

IMPORTANT SAFETY INSTRUCTIONS

When discarding or storing your old clothes dryer, remove the door.

SAVE THESE INSTRUCTIONS

INSTALLATION REQUIREMENTS

Tools and Parts

Gather the required tools and parts before starting installation.

Tools needed for all installations:

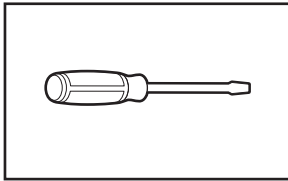

Flat-blade screwdriver

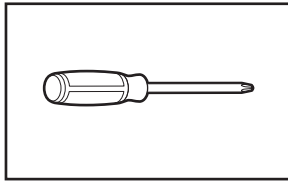

#2 Phillips screwdriver

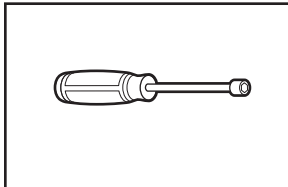

1/4" and 5/16" nut driver (recommended)

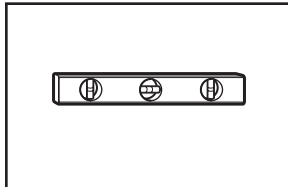

Level

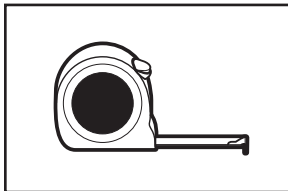

Tape measure

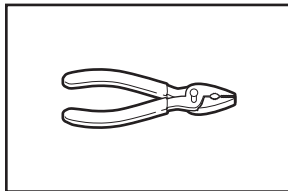

Pliers

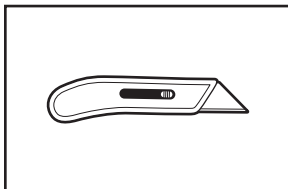

Utility knife

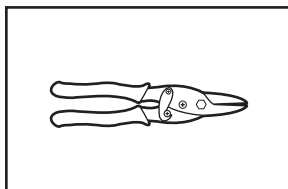

Tin snips (new vent installations)

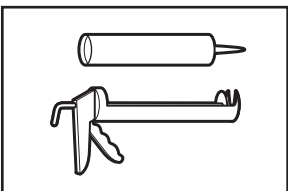

Caulking gun and compound (new vent installations)

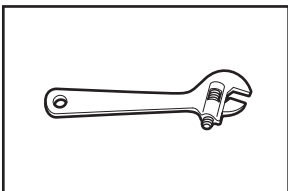

Adjustable wrench that opens to 1" or hex-head socket wrench

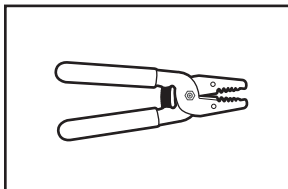

Wire stripper (direct wire installations)

Tools needed for gas installations:

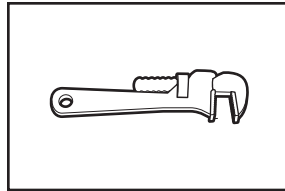

8" or 10" pipe wrench

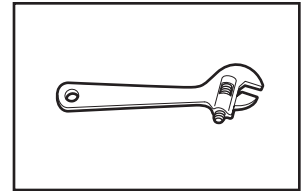

8" or 10" adjustable wrench (for gas connections)



Pipe-joint compound resistant to propane gas

Parts supplied (all models):

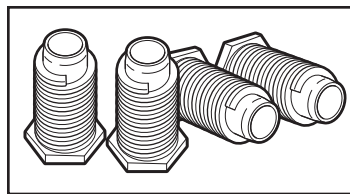

Leveling legs (4)

Parts needed (steam models):

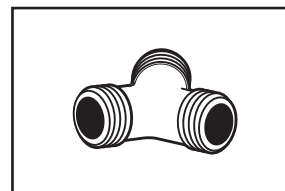

"Y" connector

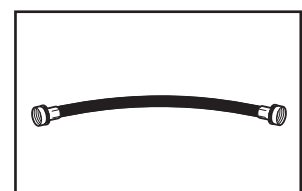

2' inlet hose

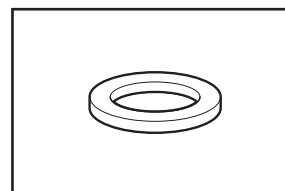

Rubber washer



5' inlet hose

Parts package is located in dryer drum. Check that all parts are included.

NOTE: Do not use leveling legs supplied with dryer if installing with a pedestal or a stack kit.

Parts needed (not supplied with dryer):

- Vent clamps
- Vent elbows and vent work

Additional parts may be required, depending on your installation. Check local codes. Check existing electrical supply and venting. Read "Electrical Requirements" and "Venting Requirements" before purchasing parts.

Optional Equipment (not supplied with dryer):

Refer to your Use and Care Guide for information about accessories available for your dryer.

LOCATION REQUIREMENTS

Check code requirements. Some codes limit, or do not permit, installing dryer in garages, closets, mobile homes, or sleeping quarters. Contact your local building inspector.

! WARNING



Explosion Hazard

Keep flammable materials and vapors, such as gasoline, away from dryer.

Place dryer at least 18 inches (460 mm) above the floor for a garage installation.

Failure to do so can result in death, explosion, or fire.

You will need:

- A location allowing for proper exhaust installation. See "Venting Requirements."
- A separate 15 or 20 A circuit for a gas dryer.
- If using power supply cord, a grounded electrical outlet located within 2 ft. (610 mm) of either side of dryer. See "Electrical Requirements."
- Floor must support dryer weight of 200 lbs. (90.7 kg). Also consider weight of companion appliance.
- Cold water faucets located within 4 ft. (1.2 m) of the water fill valves, and water pressure of 20–120 psi (138–827 kPa). You may use your washer's water supply by purchasing the necessary parts noted in "Parts needed."
- Level floor with maximum slope of 1" (25 mm) under entire dryer. If slope is greater than 1" (25 mm), install Extended Dryer Feet Kit, Part Number 279810. If not level, clothes may not tumble properly and automatic sensor cycles may not operate correctly.
- For garage installation, place dryer at least 18" (460 mm) above floor. If using a pedestal, you will need 18" (460 mm) to bottom of dryer.
- The dryer must not be installed or stored in an area where it will be exposed to water and/or weather.

IMPORTANT: Do not operate, install, or store dryer where it will be exposed to water, weather, or at temperatures below 40°F (4°C). Lower temperatures may cause dryer not to shut off at end of automatic sensor cycles, resulting in longer drying times.

DRYER DIMENSIONS

Front view:

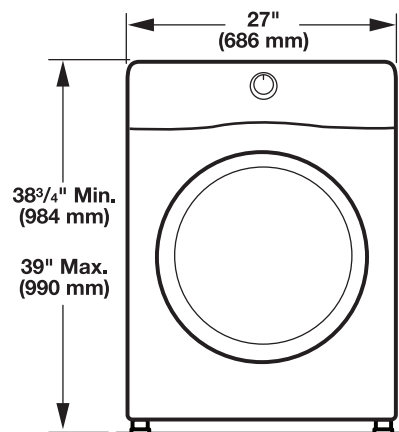

Side view:

Whirlpool Models

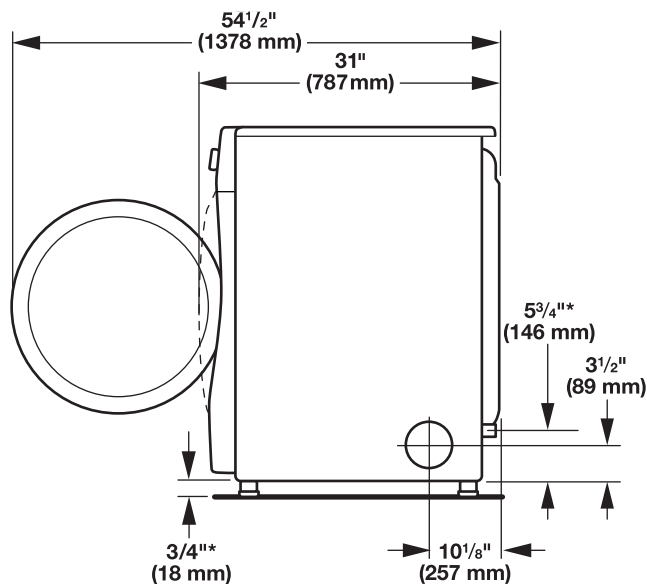

*Approx. measurement

Maytag Models

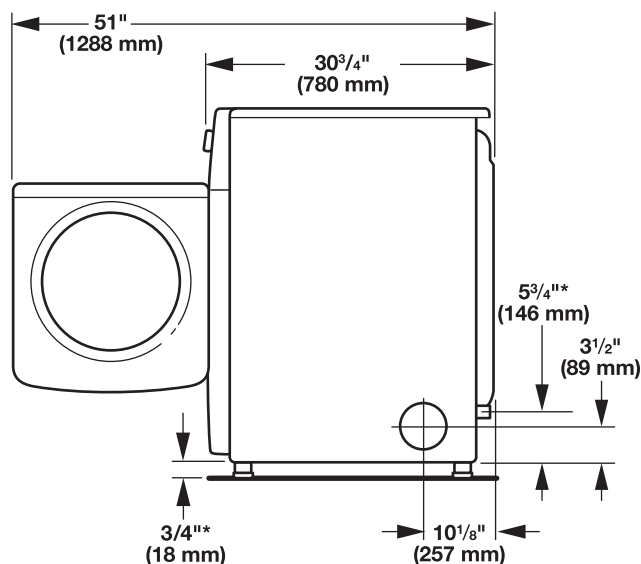

Back view:

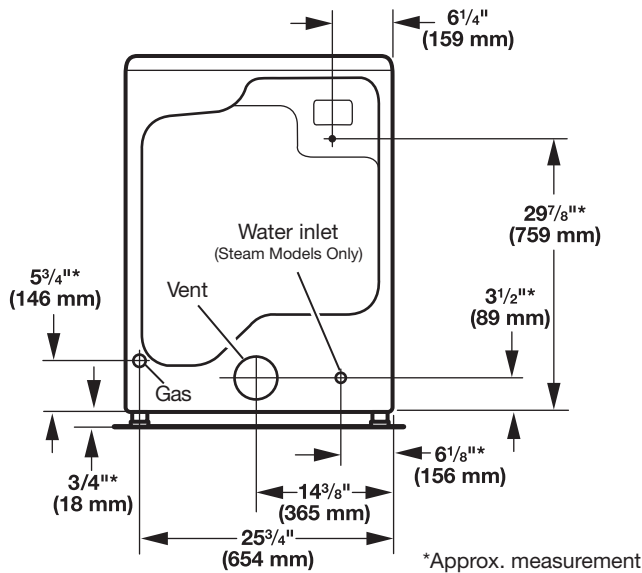

NOTE: Most installations require a minimum of 5" (127 mm) clearance behind dryer for exhaust vent with elbow. See "Venting Requirements."

Installation Clearances

For each arrangement, consider allowing more space for ease of installation and servicing, spacing for companion appliances, and clearances for walls, doors, and floor moldings. Space must be large enough to allow door to fully open. Add spacing on all sides of dryer to reduce noise transfer. If a closet door or louvered door is installed, top and bottom air openings in door are required.

Check code requirements. Some codes limit, or do not permit, installation of the dryer in garages, closets, mobile homes, or sleeping quarters. Contact your local building inspector.

NOTE: No other fuel-burning appliance can be installed in the same closet as a dryer.

Installation spacing for recessed area or closet installation

All dimensions show recommended and minimum spacing allowed.

- Additional spacing should be considered for ease of installation and servicing.
- Additional clearances might be required for wall, door, floor moldings, dryer venting, and gas line.
- Additional spacing should be considered on all sides of the dryer to reduce noise transfer.
- For closet installation with a door, minimum ventilation openings in the top and bottom of the door are required. Louvered doors with equivalent ventilation openings are acceptable.
- Companion appliance spacing should also be considered.

Recommended installation clearances (dryer only):

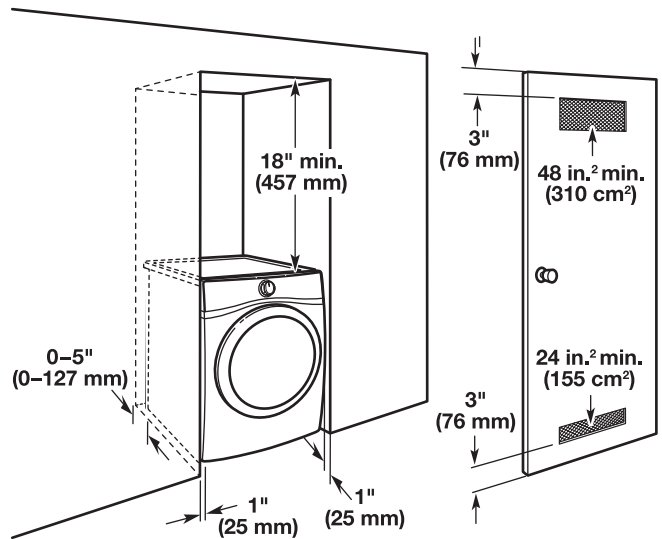

0" (0 mm) rear spacing is allowed for straight back venting only. For steam models only, inlet hose must not be kinked.

Custom under-counter installation:

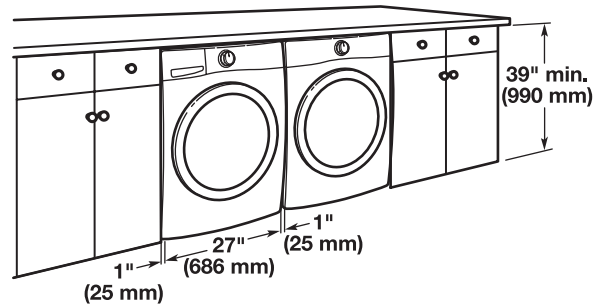

Mobile home – Additional installation requirements:

This dryer is suitable for mobile home installations. The installation must conform to the Manufactured Home Construction and Safety Standard, Title 24 CFR, Part 3280 (formerly the Federal Standard for Mobile home construction and Safety, Title 24, HUD Part 280) or Standard CAN/CSA-Z240 MH.

Mobile home installations require:

- Metal exhaust system hardware, available for purchase from your dealer. For further information, see "Assistance or Service" in your Use and Care Guide.
- Special provisions must be made in mobile homes to introduce outside air into dryer. Openings (such as a nearby window) should be at least twice as large as dryer exhaust opening.

For mobile home installation of gas dryers:

- Mobile Home Installation Hold-down Kit Part Number 346764 is available to order. For further information, see "Assistance or Service" in your Use and Care Guide.

GAS DRYER POWER HOOKUP

ELECTRICAL REQUIREMENTS

WARNING



Electrical Shock Hazard

Plug into a grounded 3 prong outlet.

Do not remove ground prong.

Do not use an adapter.

Do not use an extension cord.

Failure to follow these instructions can result in death, fire, or electrical shock.

- 120 V, 60 Hz, AC-only, 15 or 20 A fused electrical supply is required. A time-delay fuse or circuit breaker is recommended. It is also recommended that a separate circuit serving only this dryer be provided.

GROUNDING INSTRUCTIONS

- For a grounded, cord-connected dryer:
This dryer must be grounded. In the event of malfunction or breakdown, grounding will reduce the risk of electric shock by providing a path of least resistance for electric current. This dryer is equipped with a cord having an equipment-grounding conductor and a grounding plug. The plug must be plugged into an appropriate outlet that is properly installed and grounded in accordance with all local codes and ordinances.

WARNING: Improper connection of the equipment-grounding conductor can result in a risk of electric shock. Check with a qualified electrician or service representative or personnel if you are in doubt as to whether the dryer is properly grounded. Do not modify the plug provided with the dryer: if it will not fit the outlet, have a proper outlet installed by a qualified electrician.

SAVE THESE INSTRUCTIONS

GAS SUPPLY REQUIREMENTS

⚠ WARNING



Explosion Hazard

Use a new CNS approved gas supply line.

Install a shut-off valve.

Securely tighten all gas connections.

If connected to propane, have a qualified person make sure gas pressure does not exceed 13" (33 cm) water column.

Examples of a qualified person include:
licensed heating personnel,
authorized gas company personnel, and
authorized service personnel.

Failure to do so can result in death, explosion, or fire.

GAS TYPE

Natural Gas:

This dryer is equipped for use with natural gas. It is certified by UL for use with propane gas with appropriate conversion.

- Your dryer must have the correct burner for the type of gas in your home. Burner information is located on the rating plate in the door well of your dryer. If this information does not agree with the type of gas available, contact your dealer or call the phone numbers referenced in the "Assistance or Service" section of your Use and Care Guide.

Propane Gas Conversion:

IMPORTANT: Conversion must be made by a qualified technician.

No attempt shall be made to convert the appliance from the gas specified on the model/serial rating plate for use with a different gas without consulting your gas company.

GAS SUPPLY LINE

Option 1 (Recommended Method)

Flexible stainless steel gas connector:

- If local codes permit, use a new flexible stainless steel gas connector (Design Certified by the American Gas Association or CSA International) to connect your dryer to the rigid gas supply line. Use an elbow and a 3/8" flare x 3/8" NPT adapter fitting between the stainless steel gas connector and the dryer gas pipe, as needed, to prevent kinking.

Option 2 (Alternate Method)

Approved aluminum or copper tubing:

- Must include 1/8" NPT minimum plugged tapping accessible for test gauge connection, immediately upstream of the gas connection to the dryer. See illustration below.
- 1/2" IPS pipe is recommended.
- 3/8" approved aluminum or copper tubing is acceptable for lengths under 20 ft. (6.1 m) if local codes and gas supplier permit.
- If you are using natural gas, do not use copper tubing.
- Lengths over 20 ft. (6.1 m) should use larger tubing and a different size adapter fitting.
If your dryer has been converted to use propane gas, 3/8" propane compatible copper tubing can be used. If the total length of the supply line is more than 20 ft. (6.1 m), use larger pipe.
NOTE: Pipe-joint compounds that resist the action of propane gas must be used. Do not use TEFLON[†] tape.
- Must include shut-off valve.

In the U.S.A.:

An individual manual shut-off valve must be installed within six (6) ft. (1.8 m) of the dryer in accordance with the National Fuel Gas Code, ANSI Z223.1. The location should be easy to reach for opening and closing.

In Canada:

An individual manual shut-off valve must be installed in accordance with the B149.1, Natural Gas and Propane Installation Code. It is recommended that an individual manual shut-off valve be installed within six (6) ft. (1.8 m) of the dryer. The location should be easy to reach for opening and closing.

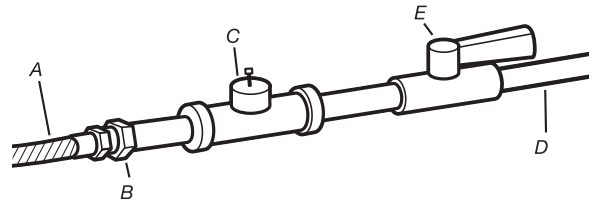

- A. 3/8" flexible gas connector
- B. 3/8" pipe to flare adapter fitting
- C. 1/8" NPT minimum plugged tapping
- D. 1/2" NPT gas supply line
- E. Gas shut-off valve

[†]TEFLON is a registered trademark of Chemours.

GAS SUPPLY CONNECTION REQUIREMENTS

- Use an elbow and a 3/8" flare x 3/8" NPT adapter fitting between the flexible gas connector and the dryer gas pipe, as needed to avoid kinking.
- Use only pipe-joint compound. Do not use TEFLON tape.
- This dryer must be connected to the gas supply line with a listed flexible gas connector that complies with the standard for connectors for gas appliances, ANSI Z21.24 or CSA 6.10.

BURNER INPUT REQUIREMENTS

Elevations above 2,000 ft. (610 m):

- When installed above 2,000 ft. (610 m) a 4% reduction of the burner Btu rating shown on the model/serial number plate is required for each 1,000 ft. (305 m) increase in elevation.

Gas supply pressure testing

- The dryer must be disconnected from the gas supply piping system during pressure testing at pressures greater than 1/2 psi.

DRYER GAS PIPE

- The gas pipe that comes out through the rear of your dryer has a 3/8" male pipe thread.

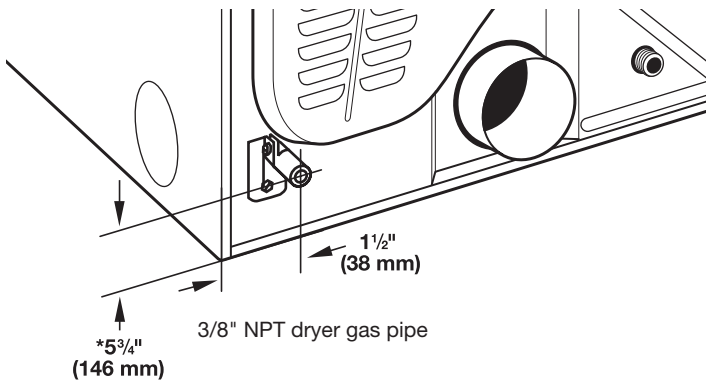

* **NOTE:** If the dryer is mounted on a pedestal, the gas pipe height must be an additional 10" (254 mm) or 15.5" (394 mm) from the floor, depending on the pedestal model. For a garage installation, the gas pipe height must be an additional 18" (460 mm) from the floor.

INSTALL LEVELING LEGS

⚠ WARNING

Excessive Weight Hazard

Use two or more people to move and install dryer.

Failure to do so can result in back or other injury.

1. Prepare dryer for leveling legs

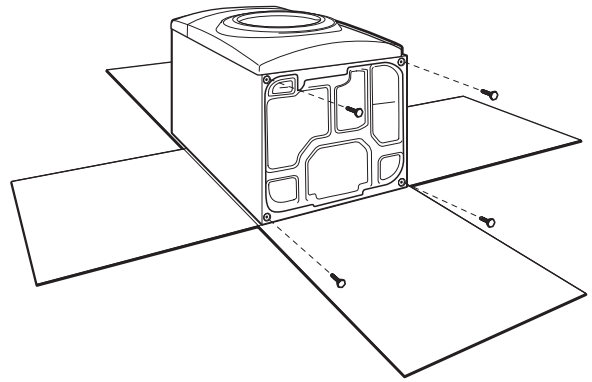

To avoid damaging floor, use a large flat piece of cardboard from dryer carton; place under entire back edge of dryer. Firmly grasp dryer body (not console panel) and gently lay dryer down on cardboard.

2. Screw in leveling legs

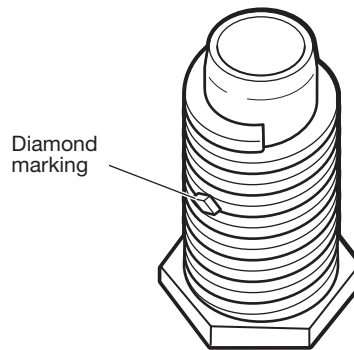

Examine leveling legs and locate the diamond marking. Screw legs into leg holes by hand – use a wrench to finish turning legs until diamond marking is no longer visible.

Place a carton corner post from dryer packaging under each of the two dryer back corners. Stand the dryer up. Slide the dryer on the corner posts until it is close to its final location. Leave enough room to connect the exhaust vent.

MAKE GAS CONNECTION

(Gas models only)

⚠ WARNING



Explosion Hazard

Use a new CNS approved gas supply line.

Install a shut-off valve.

Securely tighten all gas connections.

If connected to propane, have a qualified person make sure gas pressure does not exceed 13" (33 cm) water column.

Examples of a qualified person include:
 licensed heating personnel,
 authorized gas company personnel, and
 authorized service personnel.

Failure to do so can result in death, explosion, or fire.

1. Connect gas supply to dryer

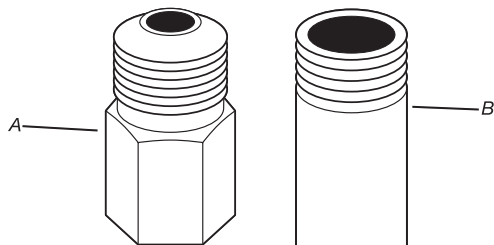

A. Flared male fitting
 B. Non-flared male fitting

Remove red cap from gas pipe. Using a wrench to tighten, connect gas supply to dryer. Use pipe-joint compound on threads of all non-flared male fittings. If flexible metal tubing is used, be sure there are no kinks.

NOTE: For propane gas connections, you must use pipe-joint compound resistant to action of propane gas. Do not use TEFLON tape.

2. Plan pipe fitting connection (Option 1)

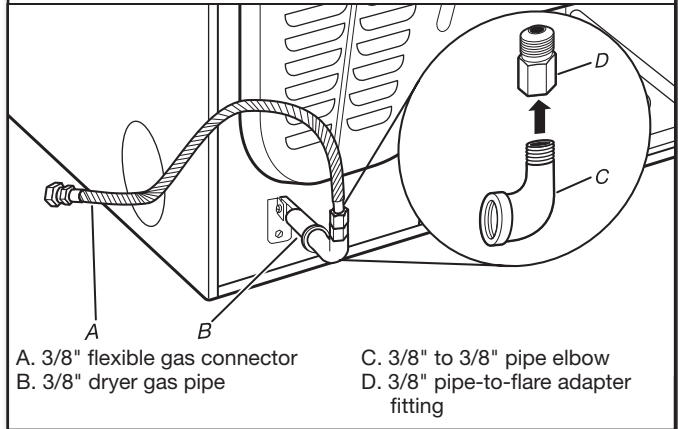

A. 3/8" flexible gas connector
 B. 3/8" dryer gas pipe
 C. 3/8" to 3/8" pipe elbow
 D. 3/8" pipe-to-flare adapter fitting

A combination of pipe fittings must be used to connect dryer to existing gas line. A recommended connection is shown. Your connection may be different, according to supply line type, size, and location.

3. Open shut-off valve

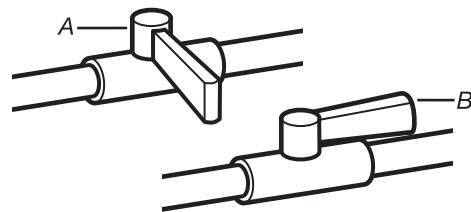

A. Closed valve
 B. Open valve

Open shut-off valve in supply line; valve is open when handle is parallel to gas pipe. Then, test all connections by brushing on an approved noncorrosive leak-detection solution. Bubbles will show a leak. Correct any leak found.

VENTING

Venting Requirements

⚠ WARNING



Fire Hazard

- Use a heavy metal vent.**
- Do not use a plastic vent.**
- Do not use a metal foil vent.**

Failure to follow these instructions can result in death or fire.

WARNING: To reduce the risk of fire, this dryer MUST BE EXHAUSTED OUTDOORS.

IMPORTANT: Observe all governing codes and ordinances. Dryer exhaust must not be connected into any gas vent, chimney, wall, ceiling, attic, crawlspace, or a concealed space of a building. Only rigid or flexible metal vent shall be used for exhausting.

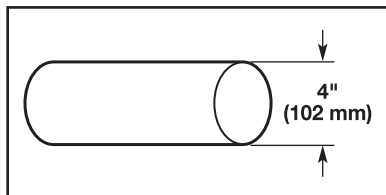

4" (102 mm) heavy metal exhaust vent

- Only a 4" (102 mm) heavy metal exhaust vent and clamps may be used.
- Do not use plastic or metal foil vent.

Rigid metal vent:

- Recommended for best drying performance and to avoid crushing and kinking.

Flexible metal vent: (Acceptable only if accessible to clean)

- Must be fully extended and supported in final dryer location.
- Remove excess to avoid sagging and kinking that may result in reduced airflow and poor performance.
- Do not install in enclosed walls, ceilings, or floors.
- The total length should not exceed 7¾ ft. (2.4 m).
- The length of flexible metal vent used must be included in the overall vent system design as shown in the "Vent System Charts."

NOTE: If using an existing vent system, clean lint from entire length of the system and make sure exhaust hood is not plugged with lint. Replace plastic or metal foil vents with rigid metal or flexible metal vents. Review "Vent System Charts" and, if necessary, modify existing vent system to achieve best drying performance.

Exhaust hoods:

- An exhaust hood should cap the vent to keep rodents and insects from entering the home.
- Must be at least 12" (305 mm) from ground or any object that may obstruct exhaust (such as flowers, rocks, bushes, or snow).
- Do not use an exhaust hood with a magnetic latch.

Recommended Styles:

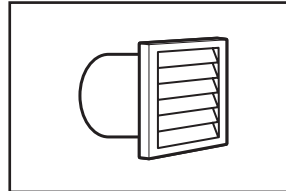

Louvered Hood

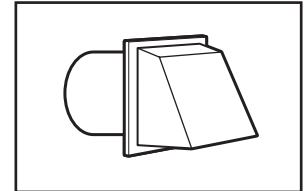

Box Hood

Acceptable Style:

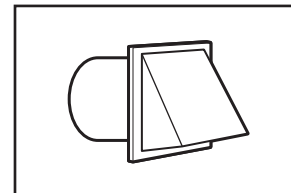

Angled Hood

Elbows:

45° elbows provide better airflow than 90° elbows.

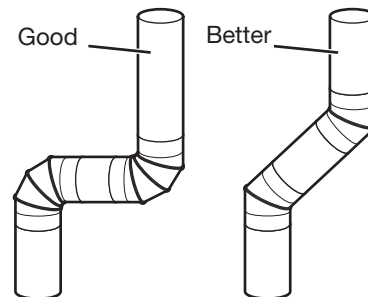

Clamps:

- Use clamps to seal all joints.
- Exhaust vent must not be connected or secured with screws or other fastening devices that extend into interior of duct and catch lint. Do not use duct tape.

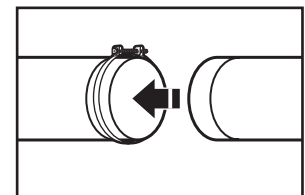
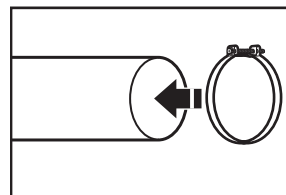

Plan Vent System

Recommended exhaust installation:

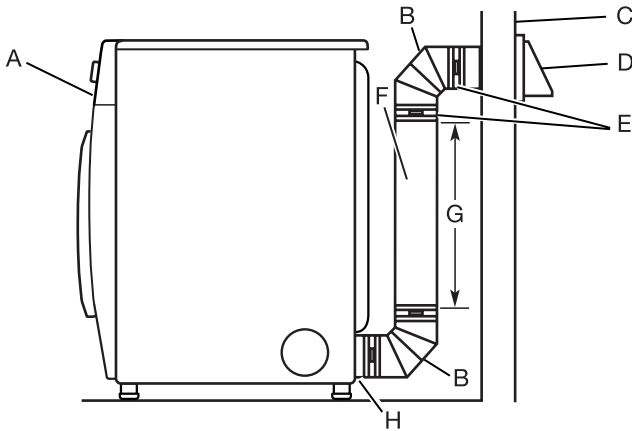

- A. Dryer
- B. Elbow
- C. Wall
- D. Exhaust hood
- E. Clamps
- F. Rigid metal or flexible metal vent
- G. Vent length necessary to connect elbows
- H. Exhaust outlet

Determine vent path:

- Select route that will provide straightest and most direct path outdoors.
- Plan installation to use fewest number of elbows and turns.
- When using elbows or making turns, allow as much room as possible.
- Bend vent gradually to avoid kinking.
- Use as few 90° turns as possible.

Determine vent length and elbows needed for best drying performance:

- Use the following “Vent System Charts” to determine type of vent material and hood combinations acceptable to use.

NOTE: Do not use vent runs longer than those specified in “Vent System Charts.”

Exhaust systems longer than those specified will:

- Shorten life of dryer.
- Reduce performance, resulting in longer drying times and increased energy usage.

The “Vent System Charts” provide venting requirements that will help achieve best drying performance.

Standard Vent System Chart

Number of 90° elbows	Type of vent	Angled hoods
0	Rigid metal	64 ft. (20 m)
1	Rigid metal	54 ft. (16.5 m)
2	Rigid metal	44 ft. (13.4 m)
3	Rigid metal	35 ft. (10.7 m)
4	Rigid metal	27 ft. (8.2 m)

⚠ WARNING



Fire Hazard

Cover unused exhaust holes with a manufacturer's exhaust cover kit.

Contact your local dealer.

Failure to follow these instructions can result in death, fire, electrical shock, or serious injury.

Optional exhaust installations:

This dryer can be converted to exhaust out the right side, left side (all models except long vent), or through the bottom. If you prefer, you may contact your local dealer to have the dryer converted.

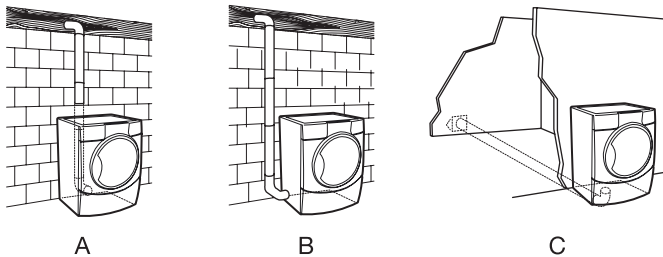

- A. Standard rear offset exhaust installation
- B. Left- or right-side exhaust installation
- C. Bottom exhaust installation

Long Vent System Chart

Number of 90° elbows	Type of vent	Angled hoods
0	Rigid metal	160 ft. (48.8 m)
1	Rigid metal	150 ft. (45.7 m)
2	Rigid metal	140 ft. (42.7 m)
3	Rigid metal	130 ft. (39.6 m)
4	Rigid metal	120 ft. (36.6 m)

To determine if your model has a long vent system, refer to the type code located on the serial number plate in the inner door well. Example: An electric model would be **DALV** – ELE – XXXXXXX-XXX. A gas model would be **DALV** – NAT – XXXXXXX-XXX.

NOTE: For long vent systems, use of box/louvered hoods will improve venting regardless of length.

Install Vent System

1. Install exhaust hood

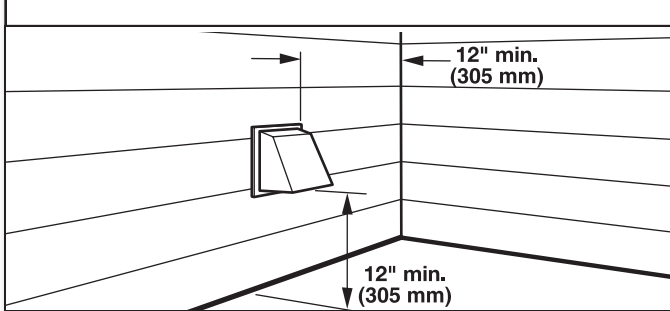

Install exhaust hood and use caulking compound to seal exterior wall opening around exhaust hood.

2. Connect vent to exhaust hood

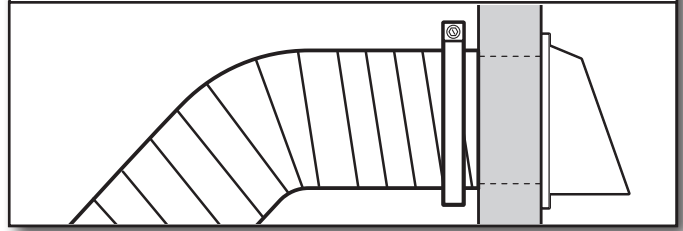

Vent must fit over the exhaust hood. Secure vent to exhaust hood with 4" (102 mm) clamp. Run vent to dryer location using straightest path possible. Avoid 90° turns. Use clamps to seal all joints. Do not use duct tape, screws, or other fastening devices that extend into interior of vent to secure vent, because they can catch lint.

CONNECT INLET HOSE (STEAM MODEL ONLY)

For non-steam models, skip to “Connect Vent.”

The dryer must be connected to the cold water faucet using the new inlet hoses (not supplied). Do not use old hoses.

NOTE: Replace inlet hoses after 5 years of use to reduce the risk of hose failure. Record hose installation or replacement dates on the hoses for future reference.

Periodically inspect and replace hoses if bulges, kinks, cuts, wear, or leaks are found.

1. Turn cold water off, remove hose, and replace rubber washer

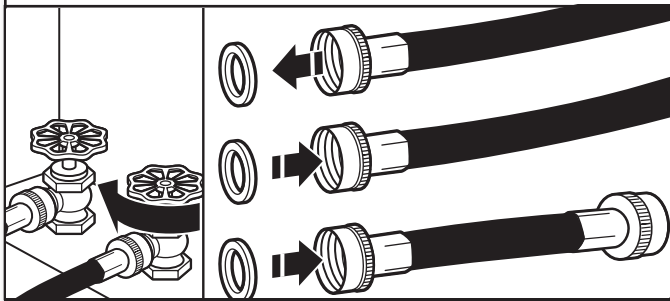

Turn cold water faucet off and remove washer inlet hose. Remove old rubber washer from inlet hose and replace with new rubber washer.

2. Attach short hose and “Y” connector

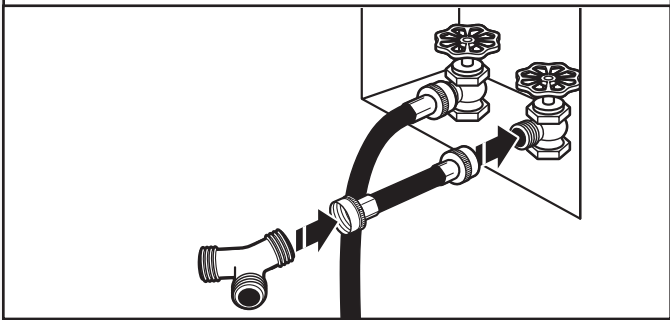

Attach 2 ft. (0.6 m) inlet hose to cold water faucet. Screw on coupling by hand until it is seated on faucet. Then attach “Y” connector to male end of the 2 ft. (0.6 m) inlet hose. Screw on coupling by hand until it is seated on connector.

3. Tighten couplings

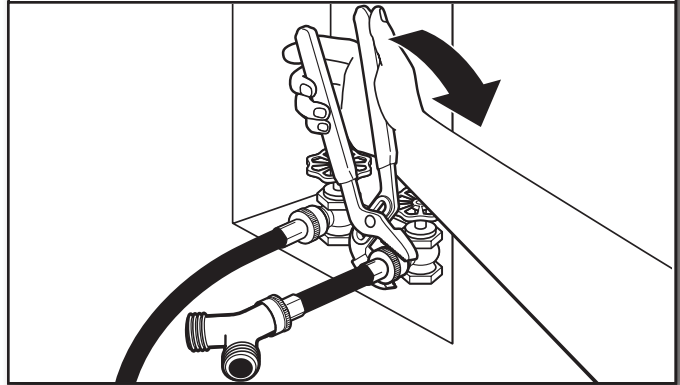

Using pliers, tighten the couplings with additional 2/3 turn. **NOTE:** Do not overtighten. Damage to the coupling can result.

4. Attach long hose to “Y” connector and tighten couplings

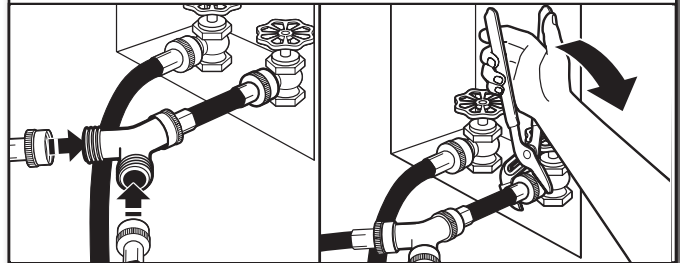

Attach one of the 5 ft. (1.5 m) inlet hose ends to the “Y” connector. Attach washer cold inlet hose to other side of “Y” connector. Screw on coupling by hand until it is seated on connector. Using pliers, tighten the couplings an additional 2/3 turn.

NOTE: Do not overtighten. Damage to the coupling can result.

5. Attach long hose to dryer fill valve and tighten coupling

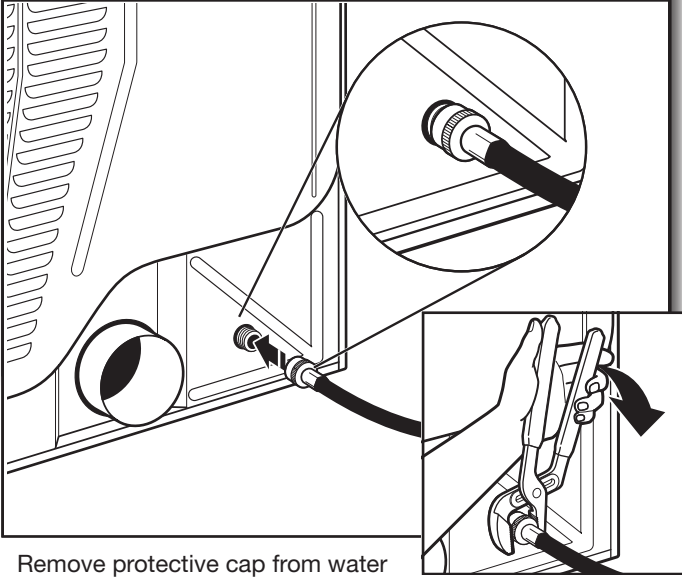

Remove protective cap from water inlet valve. Attach other end of long hose to fill valve at bottom of dryer back panel. Screw on coupling by hand until it is seated on fill valve connector. Using pliers, tighten the couplings an additional 2/3 turn.

NOTE: Do not overtighten. Damage to the coupling can result.

6. Turn on cold water faucet

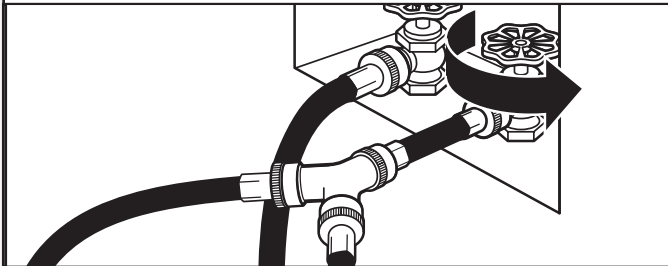

Check that the water faucets are turned on.

7. Check for leaks

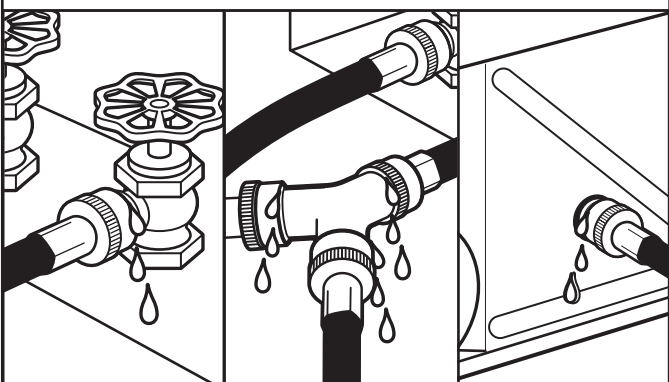

Check for leaks around "Y" connector, faucet, and hoses.

CONNECT VENT

1. Connect vent to exhaust outlet

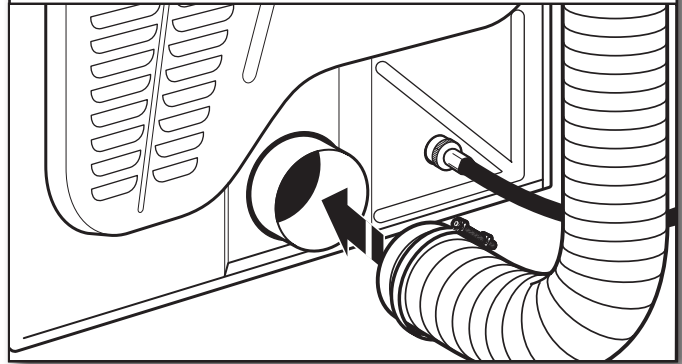

Using a 4" (102 mm) clamp, connect vent to exhaust outlet in dryer. If connecting to existing vent, make sure vent is clean. Dryer vent must fit over dryer exhaust outlet and inside exhaust hood. Check that vent is secured to exhaust hood with a 4" (102 mm) clamp.

2. Move dryer to final location

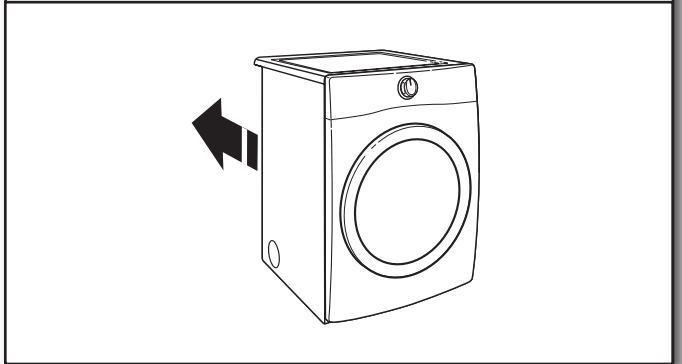

Move dryer to final location, taking care not to crush or kink vent or flexible gas line.

After dryer is in place, remove corner posts and cardboard from under dryer.

LEVEL DRYER

1. Level dryer

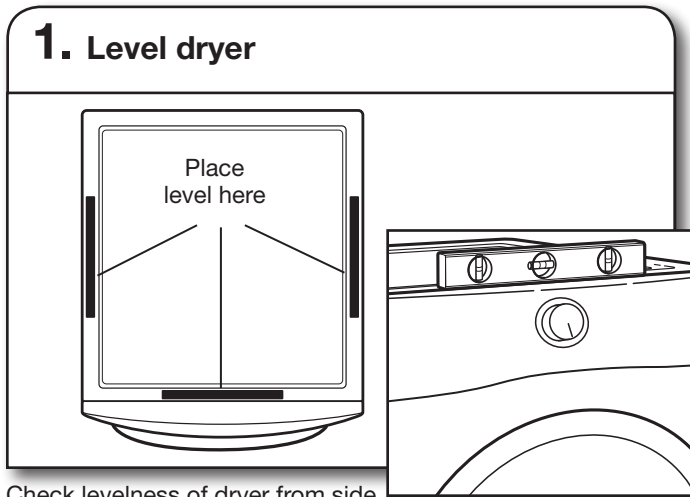

Check levelness of dryer from side to side. Repeat from front to back.

NOTE: The dryer must be level for the moisture sensing system to operate correctly.

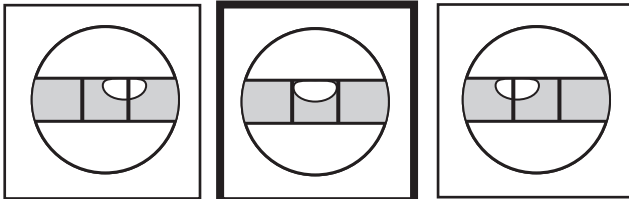

Not Level

LEVEL

Not Level

2. Adjust leveling legs

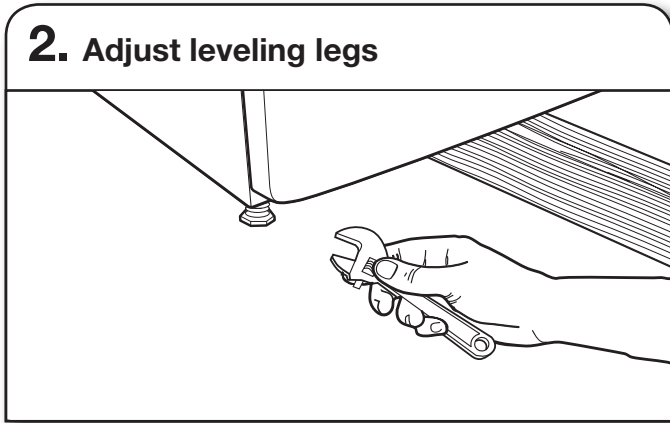

If dryer is not level, prop up using a wood block, use wrench to adjust legs up or down, and check again for levelness. Once dryer is level, make sure all four legs are snug against the floor and the dryer does not rock.

COMPLETE INSTALLATION CHECKLIST

- Check that all parts are now installed. If there is an extra part, go back through steps to see what was skipped.
- Check that you have all of your tools.
- Dispose of/recycle all packaging materials.
- Be sure the water faucets are on.
- Check for leaks around “Y” connector, faucet, and hoses.
- Check dryer’s final location. Be sure vent is not crushed or kinked.
- Check that dryer is level. See “Level Dryer.”
- Remove film on console and any tape remaining on dryer.
- Wipe dryer drum interior thoroughly with a damp cloth to remove any dust.
- Read “Dryer Use” in your Use and Care Guide.
- If you live in a hard water area, use of a water softener is recommended to control the build-up of scale through the water system in the dryer. Over time, the build-up of lime scale may clog different parts of the water system, which will reduce product performance. Excessive scale build-up may lead to the need for certain part replacement or repair.

Gas Models:

- Plug into a grounded outlet.
- Check that gas supply is on.
- Check for leaks.
- Check to be sure that the flexible gas line is not crushed or kinked.

All Models:

- Select a Timed Dry heated cycle and start dryer. Do not select Air Only Temperature setting.

If dryer will not start, check the following:

- Controls are set in a running or On position.
- Start button has been pressed firmly.
- Dryer is plugged into an outlet and/or electrical supply is connected.
- Household fuse is intact and tight, or circuit breaker has not tripped.
- Dryer door is closed.

This dryer automatically runs an installation diagnostic routine at the start of its first cycle.

NOTE: You may notice an odor when dryer is first heated. This odor is common when heating element is first used. The odor will go away.

DOOR REVERSAL (OPTIONAL)

The following instructions are for models with round and square-shaped doors.

Tools needed:

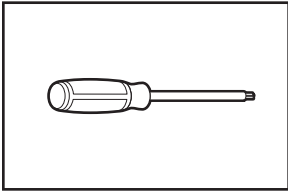

Min. 8" (203 mm) long
TORX, T20, and T25†
screwdrivers

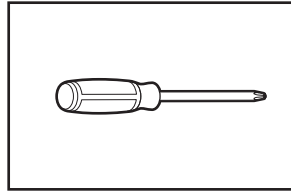

#2 Phillips screwdriver

REVERSE DOOR SWING: ROUND-SHAPED DOOR

DOORS WITH ELECTRICAL WIRING:

⚠ WARNING



Electrical Shock Hazard
Disconnect power before servicing.
Failure to do so can result in death or electrical shock.

1. Disconnect wiring from door

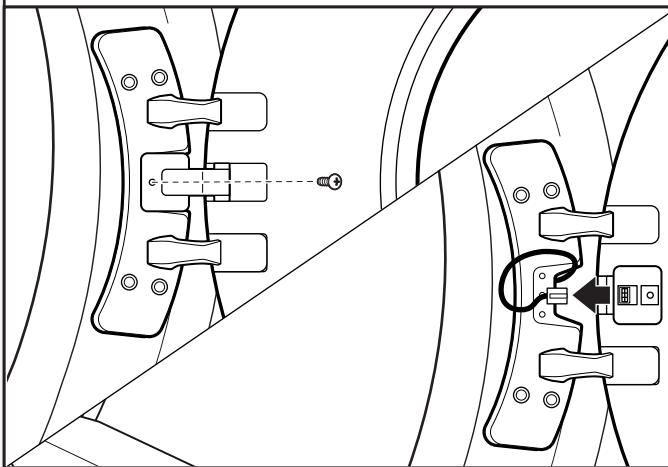

Using a Phillips screwdriver, remove middle screw in hinge. Disconnect wiring. Tuck wiring into opening.

ALL DOORS:

2. Remove door from dryer

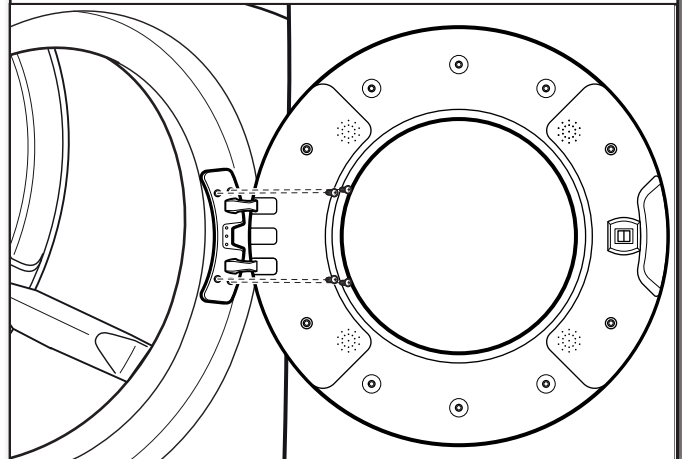

IMPORTANT: If the protective film has not yet been removed from the dryer, peel the film from the dryer door before proceeding. Using a T25 screwdriver, remove the four screws securing the door hinge to the dryer and lift the door up and out to remove. Place the door on a soft towel or other non-scratch surface.

3. Move the door strike

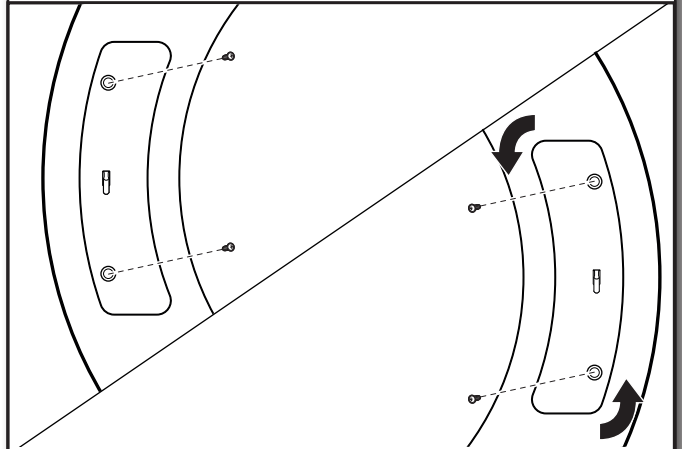

Using a T25 screwdriver, remove the two screws securing the door strike to the door frame of the dryer. Rotate the strike 180° and attach to the opposite side of dryer door frame with the two screws removed earlier, as shown.

†TORX, T20, and T25 are trademarks of Acument Intellectual Properties, LLC.

4. Remove inner door from outer door

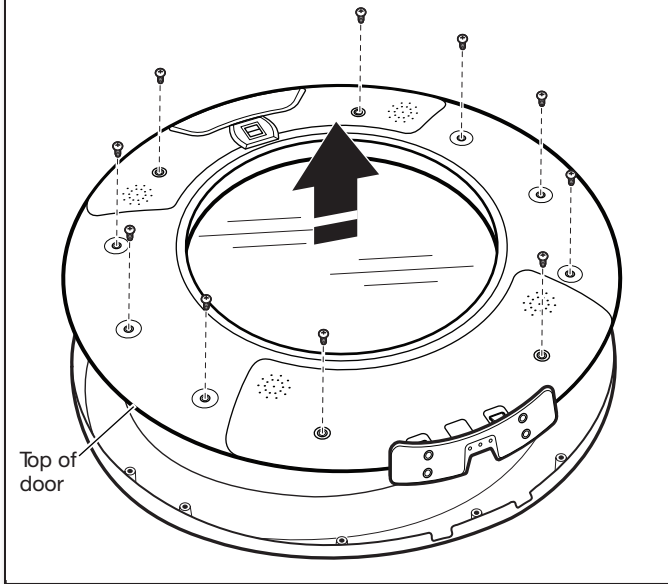

Position the door with the inside of the door facing up. Using a Phillips screwdriver, remove the 10 screws securing the inner door to the outer door.

5. Remove hinge

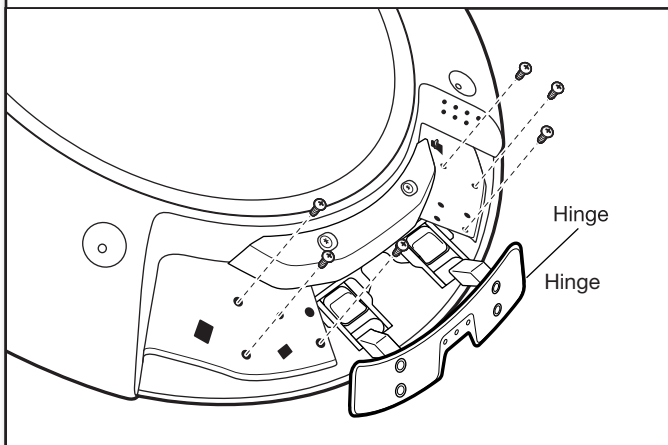

Using a T20 screwdriver, remove the six screws holding the hinge assembly in place.

6. Remove latch

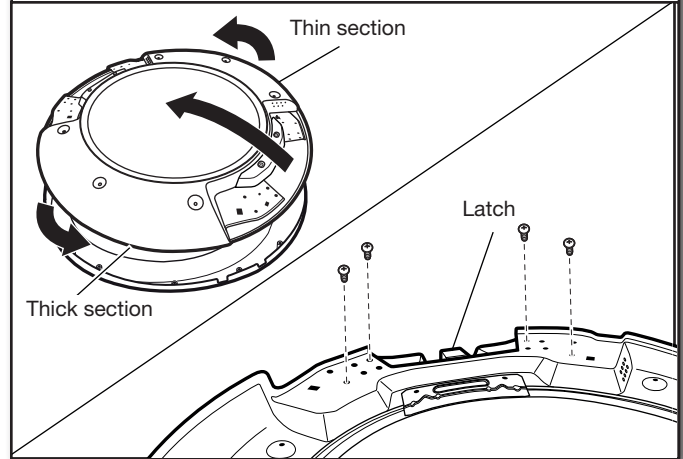

Flip and rotate the inner door 180° so that the thin section is at the top and the thick section is at the bottom. Using a T25 screwdriver, remove the four screws securing the latch plate in place.

7. Reinstall latch on opposite side

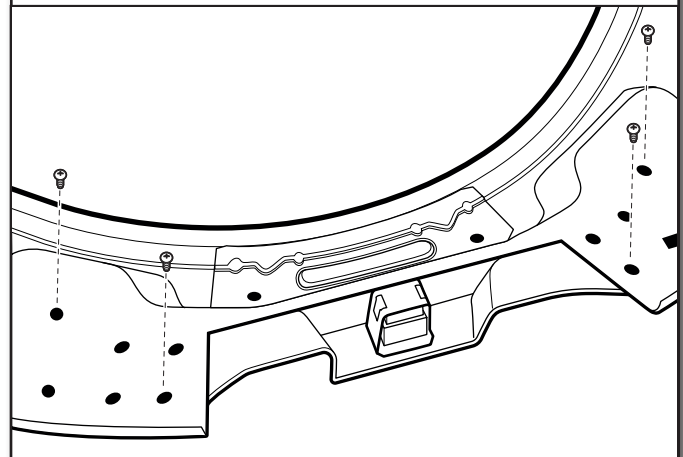

Using a T25 screwdriver, reinstall the latch plate on the opposite side from which it was removed with the four screws removed earlier.

8. Reinstall hinge assembly on opposite side

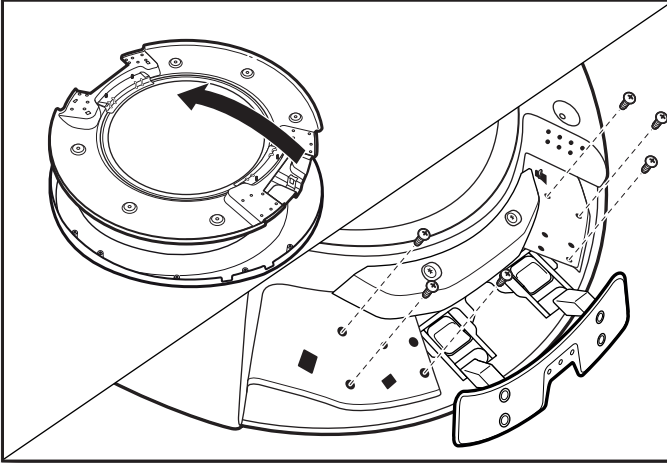

Flip over the inner door to the left. Using a T20 screwdriver, reinstall the hinge assembly on the opposite side from which it was removed.

10. Reposition rotating assembly and tubing

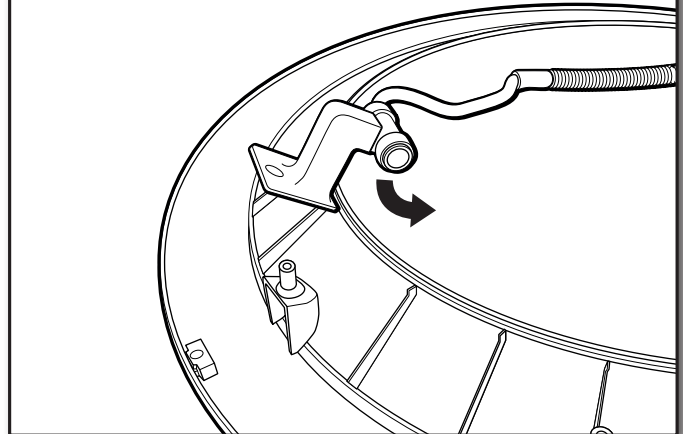

Reposition rotating assembly and tubing 180° to opposite side of the door.

DOORS WITH ELECTRICAL WIRING:

9. Remove rotating assembly

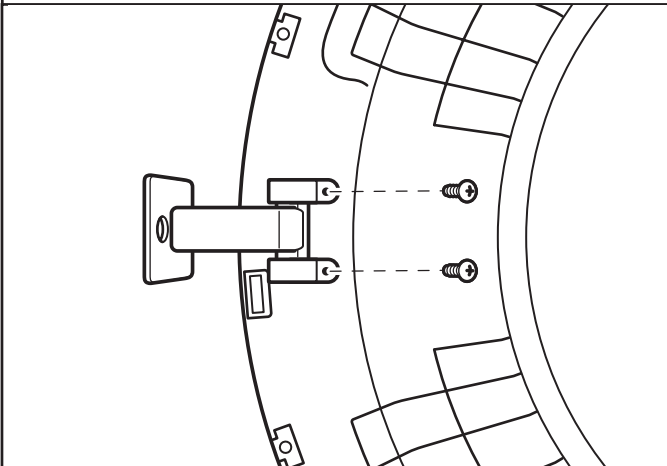

Lift off inner door assembly. Using a Phillips screwdriver, remove the two screws securing the rotating assembly to the door.

11. Rotate assembly bottom and fasten in place

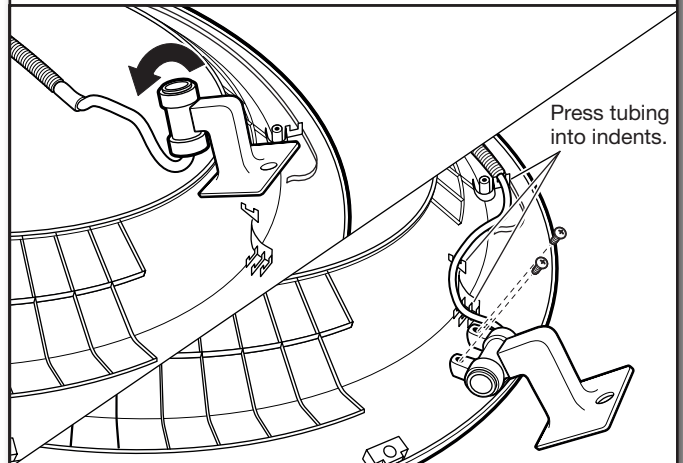

Rotate bottom of assembly 180° towards you and secure assembly with the two screws removed earlier, using a Phillips screwdriver. Press tubing into indents.

IMPORTANT: Make sure to swing hinge down in front of rotating assembly (see Step 12).

ALL DOORS:

12. Reinstall inner door assembly

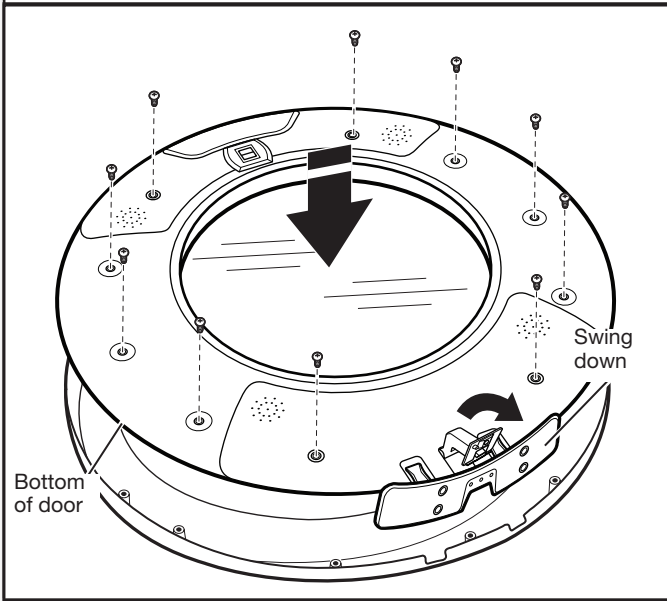

Position the door with the inside of the door facing up. Using a Phillips screwdriver, reinstall the 10 screws removed earlier, securing the inner door to the outer door.

DOORS WITH ELECTRICAL WIRING:

14. Reconnect wiring

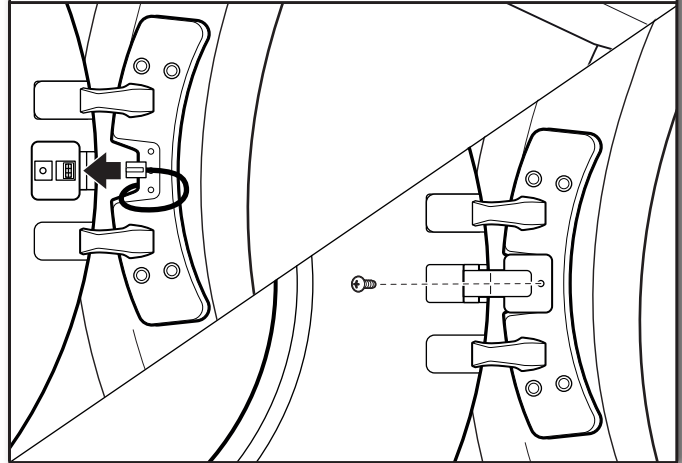

Plug in wire. Using a Phillips screwdriver, secure the rotating assembly to the hinge with the screw removed earlier.

13. Reinstall door on dryer

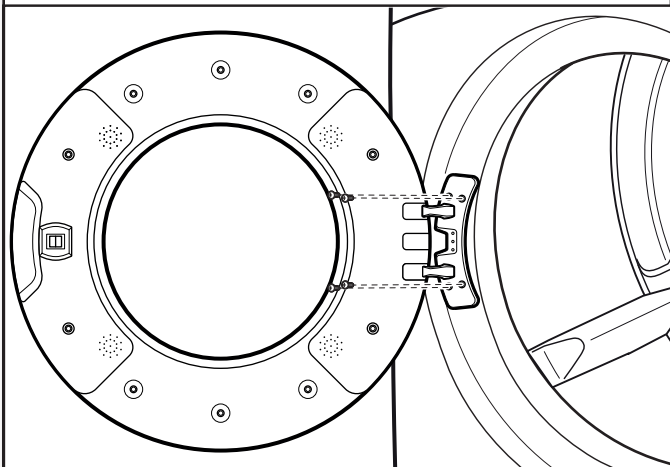

Doors with electrical wiring: Pull the wire through the front panel opening before reinstalling the door.

Insert the tabs on the hinge into the mounting slot and slide down to engage the top tab. Secure in place with the four T25 screws removed earlier.

REVERSE DOOR SWING: SQUARE-SHAPED DOOR

1. Remove door from dryer

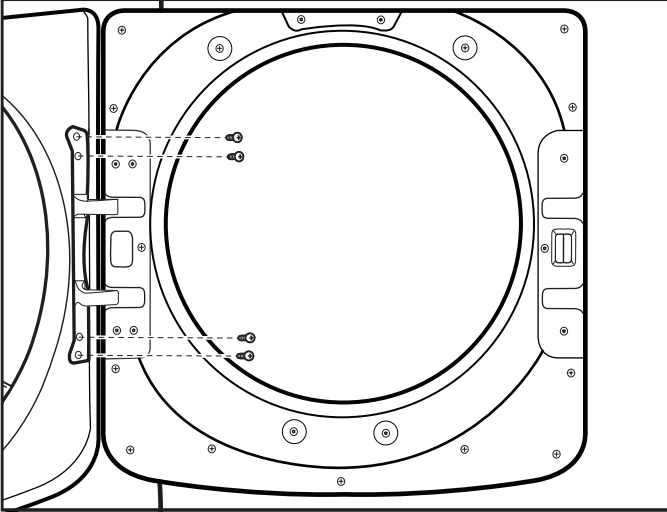

Using a T25 screwdriver, remove the four screws securing the door hinge to the dryer and lift up and out to remove the door. Place the door on a soft towel or other non-scratch surface. Retain or set aside the four screws.

2. Move the door strike

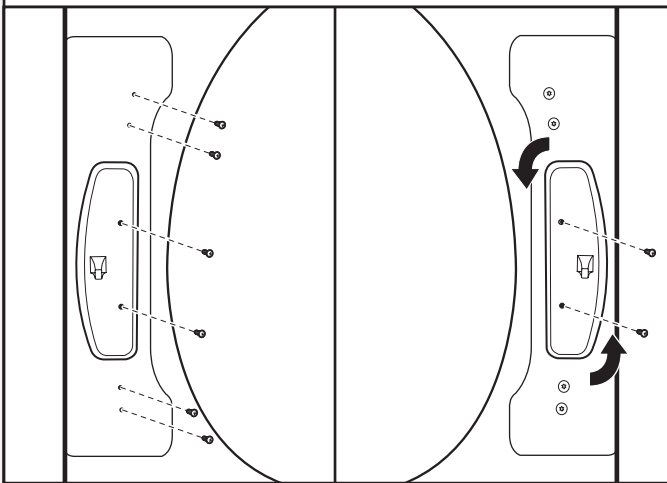

Using a T25 screwdriver, remove the two screws securing the door strike to the door frame of the dryer. Remove the four screws above and below the door strike and set aside for later use. Rotate the strike 180° and attach to the opposite side of dryer door frame, as shown.

3. Remove inner door from outer door

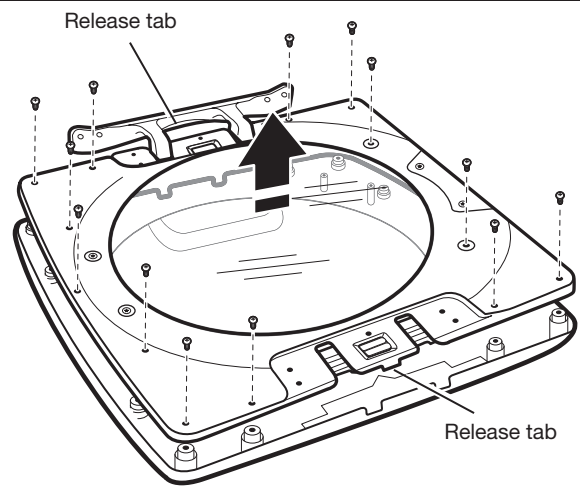

Position the door with the inside of the door facing up. Using a Phillips screwdriver, remove the 13 screws securing the inner door to the outer door. Lift off the inner door and set aside.

NOTE: There is a small release tab on each side of the door. If the inner and outer door do not separate easily, slide a credit card, putty knife, or similar flat object between the inner and outer doors at the locations shown to release the tab.

4. Remove hinge and latch from inner door

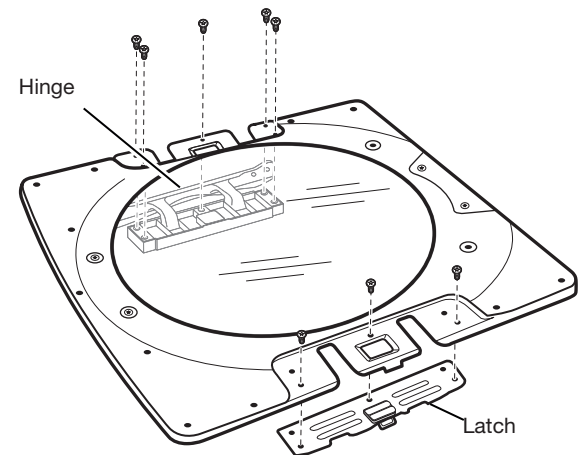

Using a T25 screwdriver, remove the three screws securing the latch plate and the five screws holding the hinge assembly in place.

5. Reinstall hinge and latch on opposite sides

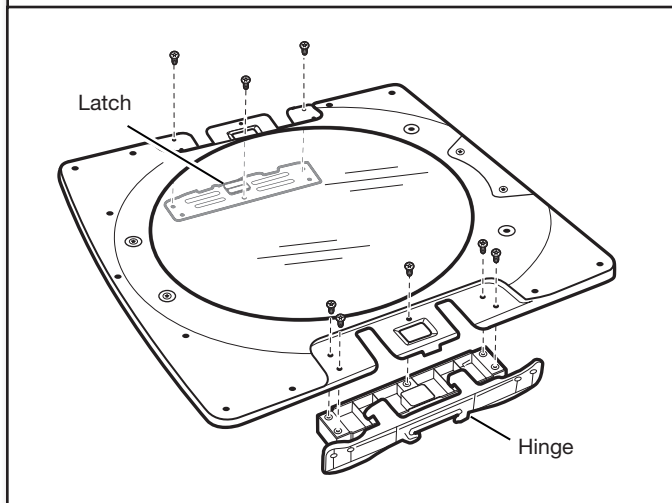

Using a T25 screwdriver, reinstall the latch plate and hinge assembly on the opposite sides from which they were removed.

7. Reattach door to dryer

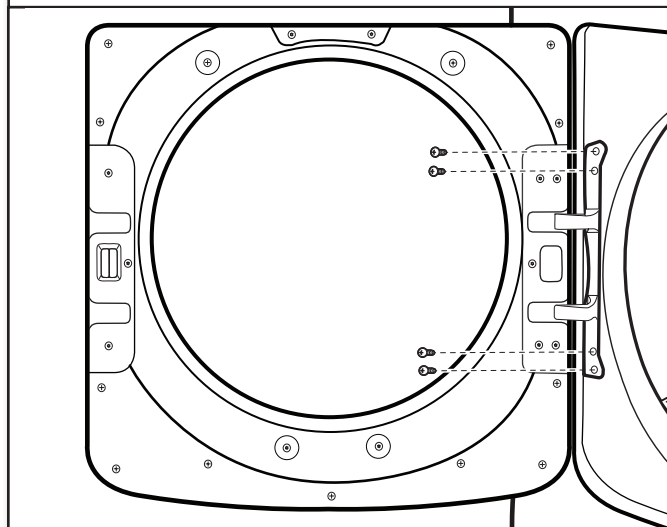

Using a T25 screwdriver, reinstall the four screws securing the door hinge to the dryer.

6. Reattach inner door to outer door

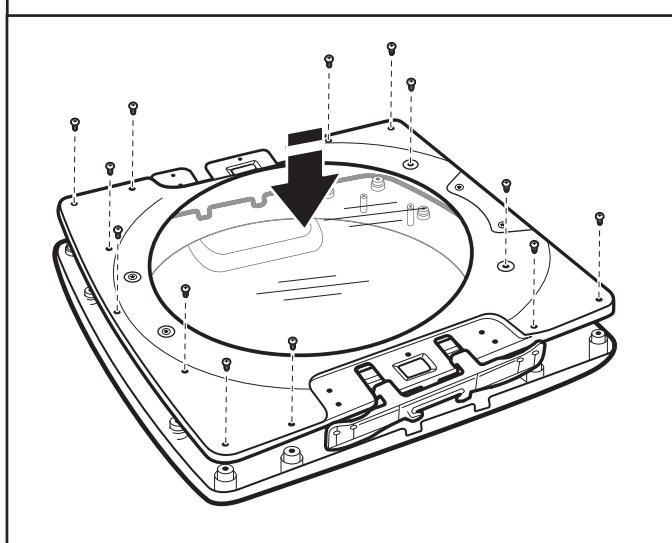

Position the inner door on the outer door assembly. Using a Phillips screwdriver, secure with the 13 screws removed earlier.

