



# WASHERS

**SAFETY INSTRUCTIONS** ..... 3

**USING THE WASHER**

Getting Started ..... 5

Loading ..... 15

Appliance Communication ..... 16

**CARE AND CLEANING** ..... 17

**INSTALLATION INSTRUCTIONS** ..... 18

**TROUBLESHOOTING TIPS** ..... 23

**LIMITED WARRANTY** ..... 27

**CONSUMER SUPPORT** ..... 28

## OWNER'S MANUAL & INSTALLATION INSTRUCTIONS

- GTW540
- GTW525
- GTW500
- GTW490
- GTW485
- GTW480
- GTW465
- GTW460
- GTW340
- GTW335
- GTW330
- GTW220
- HTW240
- HTW200

**ENGLISH/ESPAÑOL**

Write the model and serial numbers here:

Model # \_\_\_\_\_

Serial # \_\_\_\_\_

You can find them under the lid of the washer.

# GO33

**THANK YOU FOR MAKING GE APPLIANCES A PART OF YOUR HOME.**

---

Whether you grew up with GE Appliances, or this is your first, we're happy to have you in the family.

We take pride in the craftsmanship, innovation and design that goes into every GE Appliances product, and we think you will too. Among other things, registration of your appliance ensures that we can deliver important product information and warranty details when you need them.

Register your GE appliance now online. Helpful websites and phone numbers are available in the Consumer Support section of this Owner's Manual. You may also mail in the pre-printed registration card included in the packing material.



# IMPORTANT SAFETY INFORMATION

## READ ALL INSTRUCTIONS BEFORE USING THE APPLIANCE

### **▲ WARNING**

To reduce the risk of death, fire, explosion, electric shock, or injury to persons when using your appliance, follow basic precautions, including the following:

- Read all instructions before using the appliance.
- Follow all fabric care instructions and warnings to prevent melting of garments or damage to the appliance.
- **DO NOT** wash or dry articles that have been previously cleaned in, washed in, soaked in or spotted with gasoline, dry-cleaning solvents, or other flammable or explosive substances, as they give off vapors that could ignite or explode.
- **DO NOT** add gasoline, dry-cleaning solvents, or other flammable or explosive substances to the wash water. These substances give off vapors that could ignite or explode.
- Under certain conditions, hydrogen gas may be produced in a hot-water system that has not been used for 2 weeks or more. **HYDROGEN GAS IS EXPLOSIVE.** If the hot water system has not been used for such a period, before using a washing machine, turn on all hot-water faucets and let the water flow from each for several minutes. This will release any accumulated hydrogen gas. As the gas is flammable, **DO NOT** smoke or use an open flame during this time.
- **DO NOT** allow children to play on or in this appliance. Close supervision of children is necessary when this appliance is used near children. Before the washer is removed from service or discarded, remove the door or lid. Failure to follow these instructions may result in death or injury to persons.
- **DO NOT** reach into the appliance if the tub or agitator is moving to prevent accidental entanglement.
- For waterproof, water-resistant and bulky items, only use the **Bulky Items** (or **Delicates**) cycle. **DO NOT** use other cycles for these items. Using other cycles can cause excessive vibration and may result in injury or damage to the washer, walls, or floor. **DO NOT** mix waterproof and non-waterproof items.
- **DO NOT** install or store this appliance where it will be exposed to the weather.
- **DO NOT** tamper with controls, repair or replace any part of this appliance or attempt any servicing unless specifically recommended in the user maintenance instructions or in published user repair instructions that you understand and have the skills to carry out.
- **DO NOT** operate this appliance if it is damaged, malfunctioning, partially disassembled, or has missing or broken parts including a damaged cord or plug.
- Unplug the appliance or turn off the circuit breaker before servicing. Pressing the **Power** button **DOES NOT** disconnect power.
- **DO NOT** climb on or stand on this unit.
- See "ELECTRICAL REQUIREMENTS" located in the Installation Instructions for grounding instructions.

### **Proper Disposal of your Appliance**

- Dispose of or recycle your appliance in accordance with Federal and Local Regulations. Contact your local authorities for the environmentally safe disposal or recycling of your appliance.

# IMPORTANT SAFETY INFORMATION

## READ ALL INSTRUCTIONS BEFORE USING THE APPLIANCE

### PROPER INSTALLATION

This washer must be properly installed and located in accordance with the Installation Instructions before it is used.

- Ensure that the hot water hose is connected to the “H” valve and the cold water hose is connected to the “C” valve.
- Install or store where it will not be exposed to temperatures below freezing or exposed to the weather, which could cause permanent damage and invalidate the warranty.
- Properly ground washer to conform with all governing codes and ordinances. Follow details in the Installation Instructions.

#### **⚠ WARNING** - Electrical Shock Hazard

Plug into a grounded 3 prong outlet.

**DO NOT** remove ground prong.

**DO NOT** use an adapter.

**DO NOT** use an extension cord.

Failure to follow these instructions can result in death, fire or electrical shock.

- Ensure washer is properly leveled and washer legs are adjusted such that unit is stable.
- Optional drain hose extension recommended for discharging heights from 60” - 96”.
- GE Appliances strongly recommends the use of factory specified parts. A list of factory hoses available for purchase are listed. These hoses are manufactured and tested to meet GE Appliances specifications.
- GE Appliances strongly recommends the use of new water supply hoses. Hoses degrade over time and need to be replaced every 5 years to reduce the risk of hose failures and water damage.
- Consider recycling options for your appliance packaging material.

### START-UP SEQUENCE

- Any time the washer is being started or restarts after the washer lid has been opened and closed, the washer will turn on the cold water valve for two short periods followed by a 10 second pause before continuing. If the lid is opened during this period, the washer will pause. You will have to push the **Start** button again to restart the cycle.

### AUTOMATIC DRAIN SEQUENCE

- Machine will automatically drain any time the lid is left open for more than 15 minutes and water is present.
- Machine will automatically drain if left in a paused state with the lid closed for more than 24 hours and water is present.

### WHEN NOT IN USE

- Turn off water faucets to minimize leakage if a break or rupture should occur. Check the condition of the fill hoses; GE Appliances recommends changing the hoses every 5 years.

### PARTS AND ACCESSORIES

Order on-line at [GEApplianceparts.com](http://GEApplianceparts.com) today, 24 hours a day or by phone at 800.626.2002 during normal business hours. In Canada, visit your local GE Appliances parts distributor or call 800.661.1616.

Part Number	Accessory
PM14X10002	4 ft rubber water supply hoses
<b>Or</b>	
PM14X10005	4 ft braided water supply hoses
WH49X301	Drain hose extension
PM7X1	Washer Floor Tray

## READ AND SAVE THESE INSTRUCTIONS

# Getting started

**⚠ WARNING** To reduce the risk of fire, electric shock, or injury to persons, read the IMPORTANT SAFETY INFORMATION before operating this appliance.

Throughout this manual, features and appearance may vary from your model.

## Controls

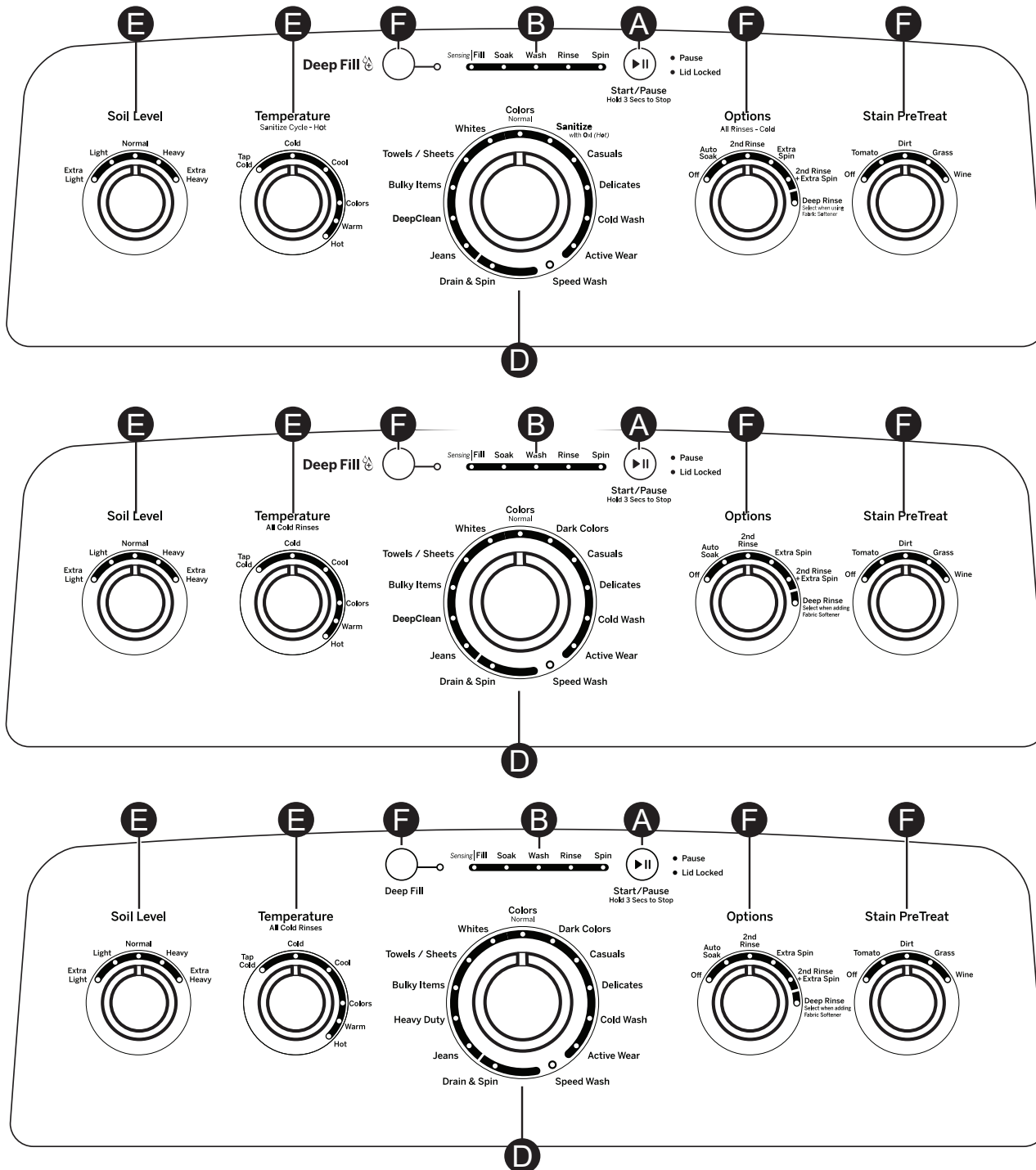

# Getting started

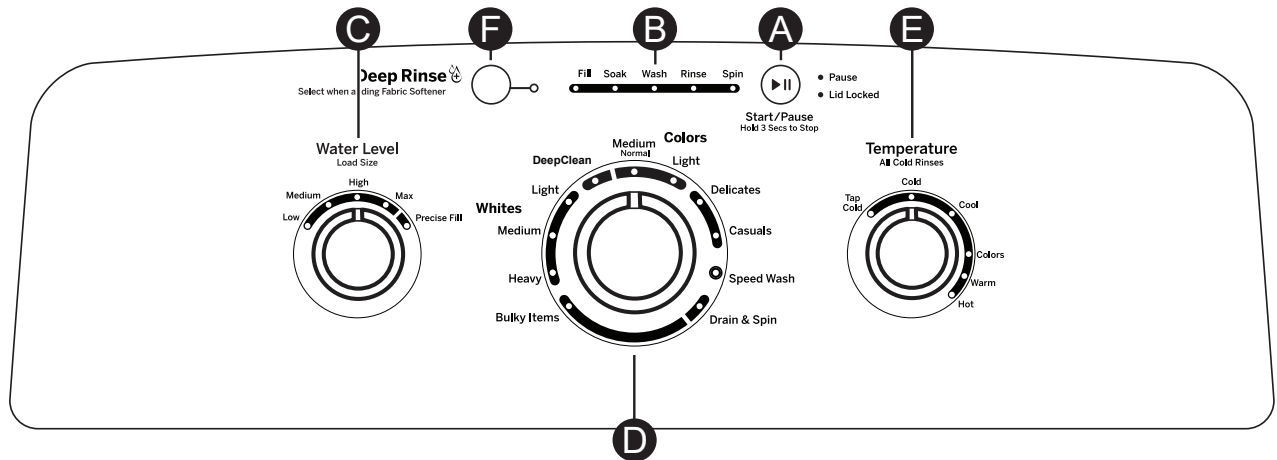
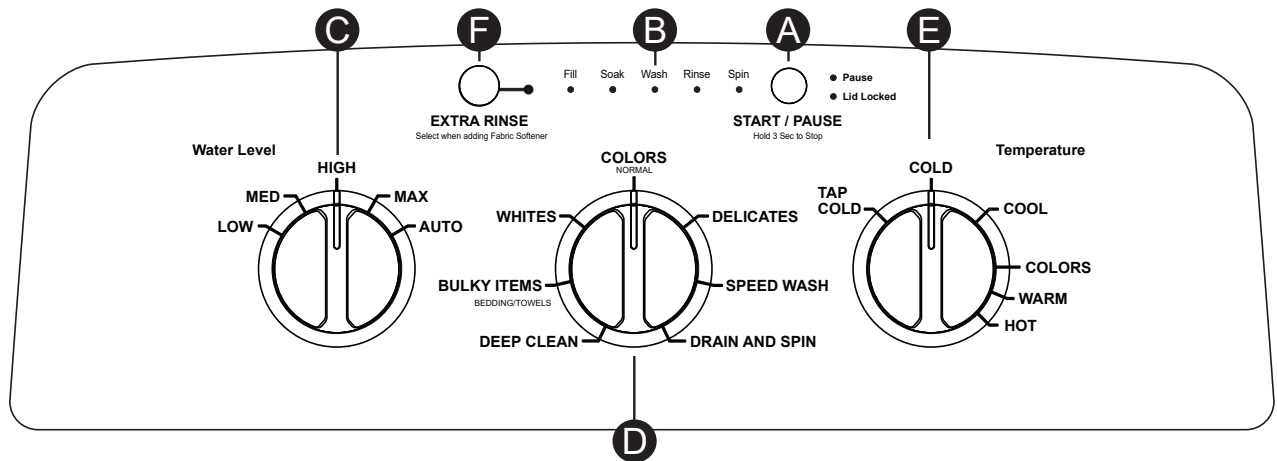
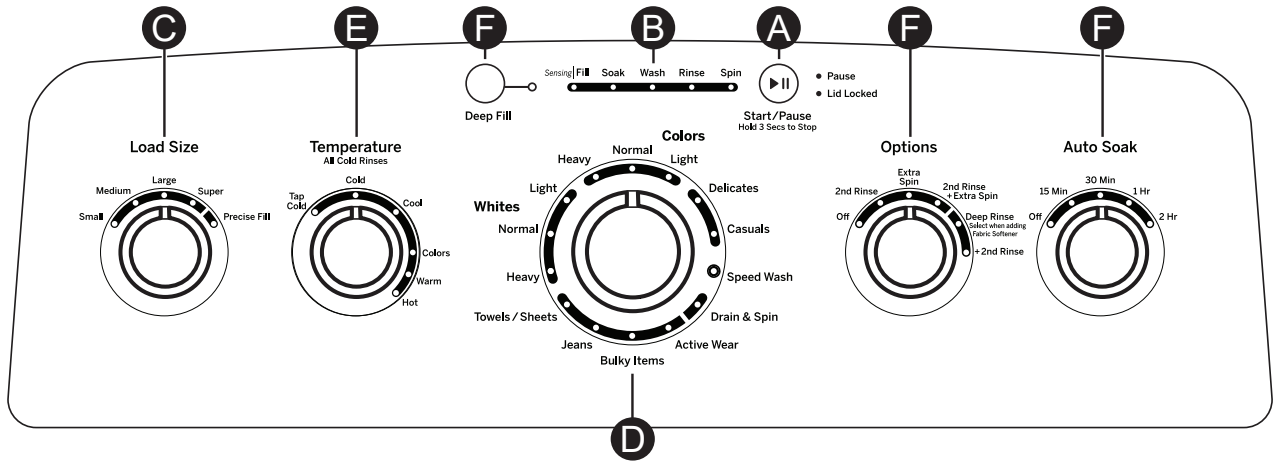
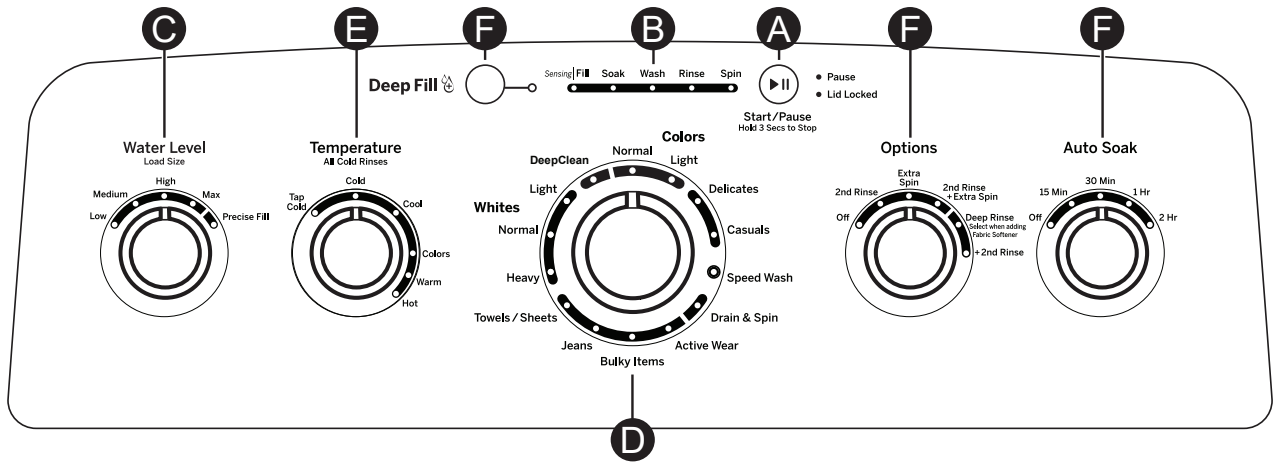

# Getting started

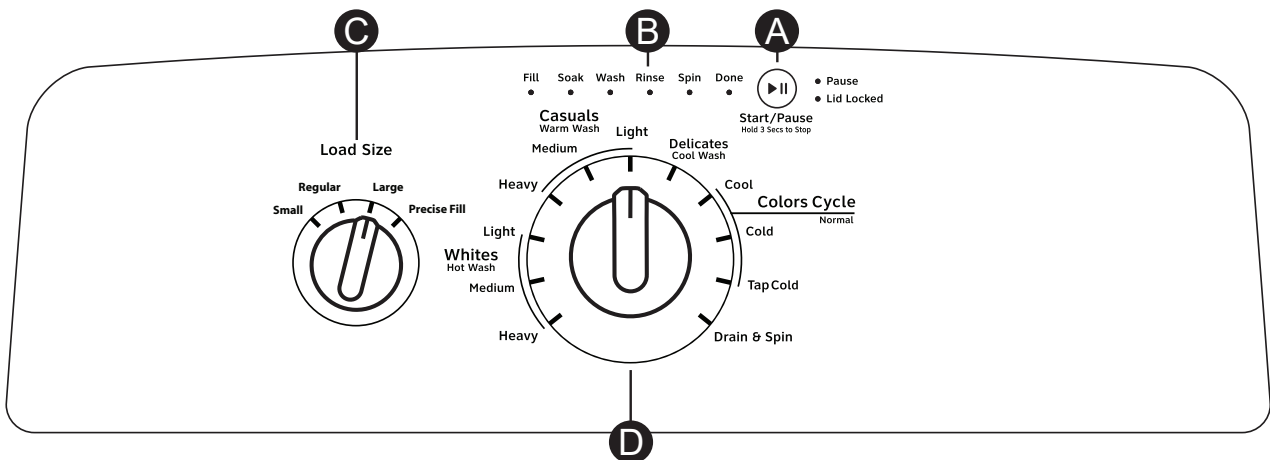
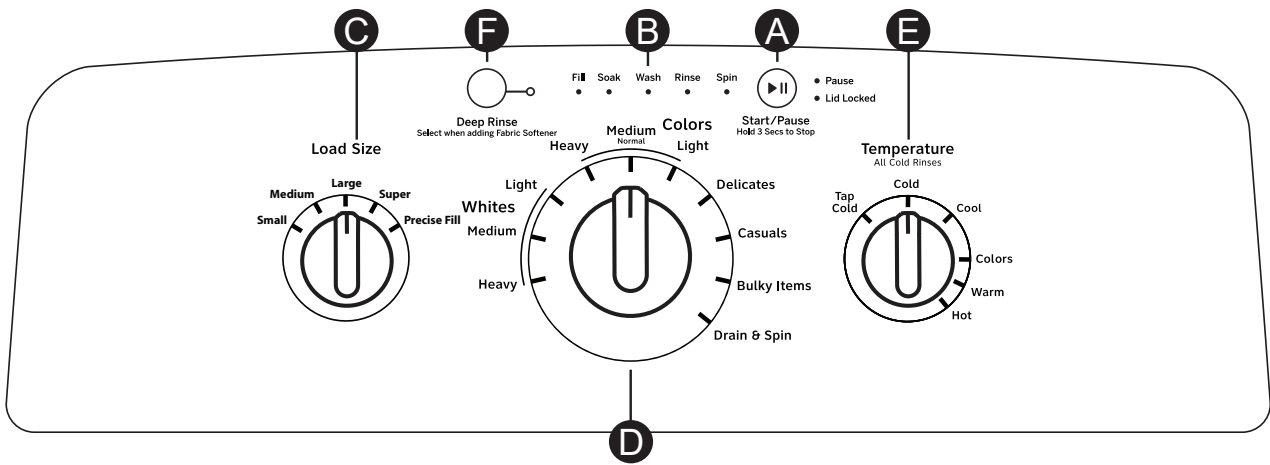
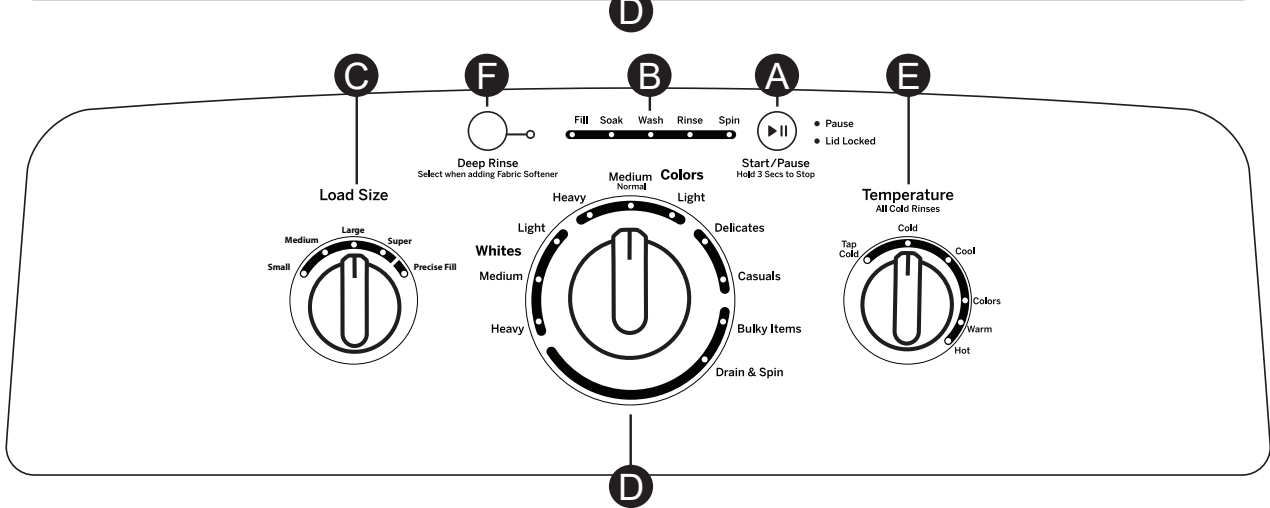
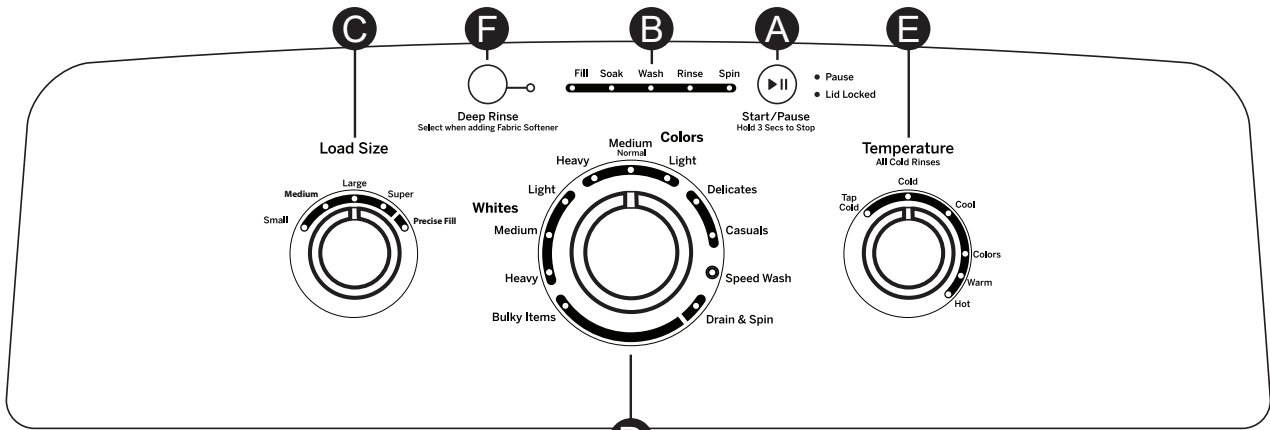

# Getting started

## Step 1



- Add fabric softener to the fabric softener dispenser (on some models); see page 14.
- If using detergent packets, add to the bottom of the wash basket before adding clothes.

## Step 2



- Loosely add items around agitator or Infusor. Overloading may negatively impact wash performance. See page 15 for suggested loading examples.
- Add the manufacturer's recommended amount of detergent to the top of the load after adding clothes. We recommend the use of High Efficiency detergents such as  in your energy efficient washer.

## Step 3



- Close lid.  
**NOTE:** Unit will not start with lid open if **Precise Fill/Auto** is selected except on **Bulky Items** cycle.
- Select wash cycle.
- Select wash options, including **Deep Rinse/Extra Rinse** option (on some models) when using fabric softener.
- Select options.
- Select load size (on some models).

## Step 4



- Press **Start**.

## A Start/Pause

Press **Start** to begin the cycle. **NOTE:** If the lid is closed, the lid will lock only during the load sensing portion of the cycle (when the **Precise Fill/Auto** selection is made or models which do not have a load size selection) and during spin portions of the cycle. Lid will unlock after load sensing and spin.

Pressing **Pause** will unlock the lid (if locked at that time), pause the cycle and the **Pause** indicator light will blink.

To continue the cycle, press **Start** again. If water remains in the machine, select the **Drain & Spin** cycle to drain basket and spin water out of the washer basket. **NOTE:** Machine will automatically cancel and drain when water is present and the lid is left open for 15 minutes or the unit is left in a paused state for 24 hours with the lid closed. Select cycle and press **Start** to begin new cycle.

## B Cycle Status Lights

Shows whether the washer is in the **Fill, Soak, Wash, Rinse** or **Spin** portion of the cycle.

If an out-of-balance condition is detected by the washer, the **Spin** light will blink during the remaining portion of the cycle and will stay illuminated for a short time after cycle completion. When this occurs, the washer is taking actions to correct the out-of-balance condition and complete the cycle normally. In some cases, the washer may not be able to balance the load and spin up to full speed. If you notice the load is more wet than normal at the end of the cycle, redistribute the load evenly in the wash basket and run a **Drain & Spin** cycle.

## C Load Size/Water Level (on some models)

Add  detergent to the bottom of the basket and fabric softener to the dispenser (on some models) prior to loading clothes.

Loosely load items in the washer basket. Overloading may negatively impact wash performance. Adjust the load size accordingly.

Make the load selection:

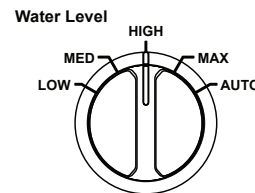
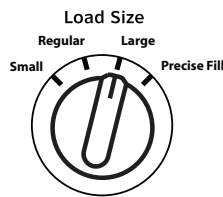
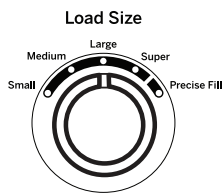
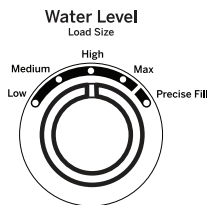

(features and appearance will vary by model)

### Precise Fill/Auto (on some models)

- For convenience, best performance and optimal efficiency, select **Precise Fill/Auto** for models so equipped. This selection automatically provides the correct amount of water suited to the size and type of load placed in the unit. Lid will be locked for the duration of the load sensing process, which includes a brief spin period and a portion of the water fill.
- If you prefer to manually select the water level, select **Low/Small** through **Max/Super** (or **Large** on some models). While **Precise Fill/Auto** is best for most loads and general washing, you may want to manually select the load size for specialty items such as bulky, lightweight comforters or pillows, where you want to ensure a larger water level is applied. Manual load size selections should be made for wet items placed in the washer, such as soaked towels or garments.
- The washer will not fill with water when **Precise Fill/Auto** is selected if the lid is opened. When the lid is closed the machine is able to begin filling with water in order to sense the load size.

**NOTE:** This is a high-efficiency washing machine. This system requires less water while providing effective cleaning action. You may notice that the water level is lower than on your previous washer. This is normal.



# Getting started

**D Wash Cycles-Cycle Selector Knob - For models GTW540, GTW525, GTW500, GTW490, GTW485, GTW480, GTW465, GTW460, GTW340, GTW335, GTW330, GTW220 & HTW240 only.**

The wash cycle controls the type of washing process. The cycle selector knob can be turned in either direction. Turning the knob after starting a cycle will stop the washer and change the cycle/options to the new selection. Press **Start** to begin the new cycle selection.

The chart below will help you match the items to be washed with the best wash cycle settings. For optimal performance, select the cycle that most closely matches the items being washed.

Selections and options shown in **bold** are the recommended settings for that cycle.

Some cycles and options may not be available on some models.

Items to Wash	Cycle	Wash Temp	Soil Level	Spin Selection (Duration)	Options Available	Cycle Details
Cycle for normal, regular, or typical use for washing up to a full load of normally soiled cotton clothing.	Colors	Hot <b>Warm</b> Colors Cool Cold Tap Cold	Ex. Heavy Heavy <b>Normal/</b> <b>Medium</b> Light Ex. Light	Max/Extra  <b>Normal</b>	Stain PreTreat Guide  Auto Soak Deep Rinse/Extra Rinse 2nd Rinse  On GTW460 Model <b>Only</b> : Deep Fill	Cycle for normal, regular, or typical use for washing up to a full load of normally soiled cotton clothing. Choose the Heavy or Extra Heavy soil level selection and Warm or Hot water temperature selection as appropriate for your clothes load for a higher degree of cleaning. Incorporates multi-stage fills and wash periods to provide optimal fabric care.
Dark colored items, linens, and mixed loads.	Dark Colors	Hot Warm Colors Cool <b>Cold</b> Tap Cold	Ex. Heavy Heavy <b>Normal/</b> <b>Medium</b> Light Ex. Light	Max/Extra  <b>Normal</b>	Stain PreTreat Guide Deep Fill Auto Soak <b>Deep Rinse/Extra Rinse</b> 2nd Rinse	Lower wash temperatures, a shorter wash period, and a deep fill rinse (on some models) minimizes fading and spotting of dark colored fabrics. Incorporates multi-stage fills and wash periods to provide optimal fabric care.
Casual clothes, lightly soiled office wear.	Casuals	Hot Warm <b>Colors</b> Cool Cold Tap Cold	Ex. Heavy Heavy <b>Normal/</b> <b>Medium</b> Light Ex. Light	Max/Extra  <b>Normal</b>	Stain PreTreat Guide Deep Fill Auto Soak Deep Rinse/Extra Rinse 2nd Rinse	Wash period tailored to care for casual clothes and office wear items. Incorporates multi-stage fills and wash periods to provide optimal fabric care.
Lingerie and special care fabrics with light soil.	Delicates	Hot Warm Colors Cool <b>Cold</b> Tap Cold	Ex. Heavy Heavy <b>Normal/</b> <b>Medium</b> Light Ex. Light	Max/Extra  <b>Normal</b>	Stain PreTreat Guide Deep Fill Auto Soak Deep Rinse/Extra Rinse 2nd Rinse	Utilizes a unique "tri-pulse" extra gentle agitate profile and a low spin speed to provide special care to delicate fabrics. It is recommended to place small or ultra delicate items in mesh bags before washing.
Dark colored fabrics and mixed loads.	Cold Wash	Hot Warm Colors Cool Cold <b>Tap Cold</b>	Ex. Heavy Heavy <b>Normal/</b> <b>Medium</b> Light Ex. Light	Max/Extra  <b>Normal</b>	Deep Fill Auto Soak Deep Rinse/Extra Rinse 2nd Rinse	Cycle combines multiple extended wash agitation periods with soak periods to provide enhanced cleaning performance and energy efficiency with colder water temperatures.
Medium to lightly soiled athletic wear items of technical or synthetic fabrics.	Active Wear	Hot <b>Warm</b> Colors Cool Cold Tap Cold	Ex. Heavy Heavy <b>Normal/</b> <b>Medium</b> Light Ex. Light	Max/Extra  <b>Normal</b>	Stain PreTreat Guide Deep Fill Auto Soak Deep Rinse/Extra Rinse 2nd Rinse	Cycle designed for care of medium to lightly soiled active wear, athletic wear, and technical fabrics. Incorporates a multi stage wash period with soak to effectively treat body soils and odors. Use the Heavy Duty cycle for heavily soiled sports clothing constructed of sturdy fabric.
Small loads of lightly soiled items that are needed in a hurry.	Speed Wash	Hot <b>Warm</b> Colors Cool Cold Tap Cold	Ex. Heavy Heavy <b>Normal/</b> <b>Medium</b> Light Ex. Light	Max/Extra  <b>Normal</b>	Stain PreTreat Guide Deep Fill Auto Soak Deep Rinse/Extra Rinse 2nd Rinse	Utilizes an expedited wash period and time saving continuous spray rinse to clean small lightly soiled loads in the fastest time possible.

# Getting started

**D** Wash Cycles-Cycle Selector Knob - Continued - For models GTW540, GTW525, GTW500, GTW490, GTW485, GTW480, GTW465, GTW460, GTW340, GTW335, GTW330, GTW220 & HTW240 only.

Items to Wash	Cycle	Wash Temp	Soil Level	Spin Selection (Duration)	Options Available	Cycle Details
Wet load of items. For items that need only to be rinsed, use this cycle with Deep Rinse/Extra Rinse option.	Drain & Spin			Max/Extra <b>Normal</b>	Deep Rinse/Extra Rinse 2nd Rinse	Utilizes a high speed spin to extract water from wet items. For items that need to be rinsed, select the Deep Rinse/Extra Rinse and/or 2nd Rinse option when using this cycle.
Jeans with medium to light soil. For heavily soiled work jeans, use the Heavy Duty Cycle.	Jeans	Hot Warm Colors Cool <b>Cold</b> Tap Cold	Ex. Heavy Heavy <b>Normal/</b> <b>Medium</b> Light Ex. Light	Max/Extra <b>Normal</b>	Stain PreTreat Guide Deep Fill Auto Soak Deep Rinse/Extra Rinse 2nd Rinse	Combines higher water levels, a specially designed agitation profile, and multi step wash and soak periods to care for jeans with medium to light soil. Use the Heavy Duty cycle for heavily soiled work jeans.
Sturdy fabrics with heavy soil.	Deep Clean	Hot <b>Warm</b> Colors Cool Cold Tap Cold	Ex. Heavy <b>Heavy</b> Normal/ Medium Light Ex. Light	Max/Extra <b>Normal</b>	Stain PreTreat Guide Deep Fill Auto Soak Deep Rinse/Extra Rinse 2nd Rinse	Incorporates multi-step wash and soak periods combined with extended wash periods to effectively clean heavily soiled sturdy fabrics.
Water-resistant, bedding and bulky items, such as large coats, mattress pads, and bath mats.	Bulky Items	Hot <b>Warm</b> Colors Cool Cold Tap Cold	Ex. Heavy Heavy <b>Normal/</b> <b>Medium</b> Light Ex. Light	Max/Extra <b>Normal</b>	Stain PreTreat Guide <b>Deep Fill</b> Auto Soak <b>Deep Rinse/Extra Rinse</b> 2nd Rinse	Provides a Deep Fill/max fill wash water level to wash bulky and waterproof items. Also incorporates a Deep Fill rinse to effectively rinse bulky items and a low spin speed appropriate for these items. <b>Only use this cycle for water-resistant, bedding or bulky items.</b>
Towels. Sheets.	Towels / Sheets	Hot <b>Warm</b> Colors Cool Cold Tap Cold	Ex. Heavy Heavy <b>Normal/</b> <b>Medium</b> Light Ex. Light	Max/Extra <b>Normal</b>	Stain PreTreat Guide Deep Fill Auto Soak Deep Rinse/Extra Rinse 2nd Rinse	Cycle designed washing towels or sheets, using a higher water level and a soak period to effectively clean these items. It is recommended that towels and sheets be washed separately for best care and washing performance. For waterproof bed covers use <b>Bulky Items</b> cycle.
Whites and household linens	Whites	<b>Hot</b> Warm Colors Cool Cold Tap Cold	Ex. Heavy Heavy <b>Normal/</b> <b>Medium</b> Light Ex. Light	Max/Extra <b>Normal</b>	Stain PreTreat Guide Deep Fill Auto Soak Deep Rinse/Extra Rinse 2nd Rinse	Cycle tailored to clean and brighten your whites.
Heavily soiled colorfast items.	Sanitize with Oxi*	<b>Hot</b>	<b>Ex. Heavy</b>	<b>Max/Extra</b>	Auto Soak Deep Rinse/Extra Rinse 2nd Rinse	Cycle uses an initial lower water fill for super concentrated, high temperature sanitization followed by a heavy wash step. A pump purge and deep rinse is incorporated to remove contaminants. See additional details below.

**\*Sanitize with Oxi**

The **Sanitize With Oxi** cycle, when using an Oxi additive along with your detergent, is designed to remove 99.9% of bacteria found in home laundry. Measure the detergent and the Oxi products carefully. Using the amounts appropriate for a large heavily soiled load in a top load washer, follow the detergent and the Oxi product label instructions. For the **Sanitize With Oxi** cycle only, add the clothes first and then place the detergent and Oxi product directly on top of the load. The washer hot water supply connection must provide a minimum of 120°F to ensure the effectiveness of this cycle.

**NOTE:** The **Sanitize with Oxi** cycle will use the HOT water and Extra Heavy soil setting regardless of the actual settings on the **Temperature** and **Soil Level** knobs. The lid will be locked during the wash cycle. **Pause** can be pressed to unlock the lid. The **Stain PreTreat** option is not available.

# Getting started

**D Wash Cycles-Cycle Selector Knob - Continued - For models GTW540, GTW525, GTW500, GTW490, GTW485, GTW480, GTW465, GTW460, GTW340, GTW335, GTW330, GTW220 & HTW240 only.**

**▲ WARNING** Failure to closely follow these instructions may result in an abnormal vibrating and out-of-balance condition that could result in physical injury, property damage, and/or appliance damage.

**For Waterproof, Water-Resistant, or Bulky:**

- Only use the **Bulky** (or **Delicates**) cycle.
- Using other cycles can cause excessive vibration and may result in injury or damage to the washer, walls, or floor.
- Do not mix waterproof and non-waterproof items.
- Read the **Owner's Manual** for wash cycle details.

**D Wash Cycles-Cycle Selector Knob - For model HTW200 only.**

The wash cycle controls the type of washing process. The cycle selector knob can be turned in either direction. Turning the knob after starting a cycle will stop the washer and change the cycle options to the new selection. Press **Start** to begin the new cycle selection.

The chart below will help you match the items to be washed with the best wash cycle settings. For optimal performance, select the cycle that most closely matches the items being washed.

Items to Wash	Cycle	Wash Temp	Soil Level	Spin Selection (Duration)	Cycle Details
Cycle for normal, regular, or typical use for washing up to a full load of normally soiled cotton clothing.	Colors	Cool Cold Tap Cold	Normal	Normal	Cycle for normal, regular, or typical use for washing up to a full load of normally soiled cotton clothing. Multiple wash temperature selections are available within this single cycle: Tap Cold: Coldest selection available, adds no hot water. Cold: Adds some hot water to aid dissolving detergents in colder climates. Cool: Adds more hot water to increase cleaning. The Normal cycle is identical in cycle steps, wash times, etc. for each wash temperature selection available. All rinses are cold.
Whites and household linens	Whites	Hot	Heavy Medium Light	Normal	Provides the hottest hot temperature available (based on your water heater setting) with longer wash periods to clean and brighten your whites. It is recommended that a Oxi or chlorine bleach product appropriate for items being washed be used with this cycle to maximize whitening performance. Note that three soil levels are available: Heavy, Regular, and Light. Rinse is cold.
Light colored items. More heavily soiled or items with body soils.	Casuals	Warm	Heavy Medium Light	Normal	Wash temperature and wash profile tailored for items that are more heavily soiled and/or contain body soils. Note that three soil levels are available: Heavy, Regular, and Light. Rinse is cold.
Lingerie and special care fabrics with light soil. Water-resistant, bedding and bulky items, such as large coats, mattress pads, and bath mats.	Delicates	Cool	Light	Normal	Utilizes a unique "tri-pulse" extra gentle agitate profile and a low spin speed to provide special care to delicate fabrics. It is recommended to place small or ultra delicate items in mesh bags before washing.
Wet load of items.	Drain & Spin			Normal	Utilizes a high speed spin to extract water from wet items.

**NOTE:** Water temperature selections are embedded within the wash cycles. For the **Colors Cycle Normal**, there are multiple temperature selections available. For other cycles, such as **Whites**, there is only one temperature available but there are multiple soil levels embedded. Select the cycle, temperature and soil level that best matches items being washed.

# Getting started

## **F** Settings

Select settings for agitation (**Soil**) and water temperature (**Temp**).

**NOTE:** Longer **Spin** times typically reduce dryer time/energy usage (i.e. reduces total energy when using both a washer and a dryer).

## **F** Cycle Options (on some models)

### Stain PreTreat

The **Stain PreTreat** feature allows you to indicate what stains are on the garments in your load. An initial water fill is performed at a temperature tailored to the stain type selected and to an amount which enables a concentrated cleaning step. A stain scrubbing period, followed by an active soak, is conducted to effectively treat the stain. Then additional water is added to the selected temperature and the wash phase is conducted for the cycle selected. For washing normally soiled cotton clothing the **Stain PreTreat** option should be in the **Off** position.

This feature can be applied to most wash cycles as described in the cycle guide.

#### To use **Stain PreTreat**:

1. Select the desired wash cycle.
2. Select the stain to be treated under the **Stain PreTreat** options.

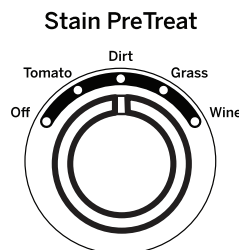

**Stain PreTreat Guide**

Category	Recommended Temperatures Treatment/Wash	Stain	For best results, before placing in washer:
Tomato	Cool/Warm	Sauce Catsup Salsa	Pretreat with liquid detergent or stain remover product; rinse with cool water.
Dirt	Cool/Warm	Dirt Clay Mud	Allow dirt to dry; remove loose dirt using a brush. Rinse with cool water.
Grass	Cold/Warm	Grass Lipstick Chocolate Gravy Mayonnaise BBQ Sauce	Pretreat with liquid detergent or stain remover product. Brush lightly; rinse with cold water.
Wine	Cool/Warm	Wine Soda Kool-Aid Tea Coffee Juice Beer	Pretreat with mixture of Oxi product and cool water. Add Oxi product along with detergent in the washer.

- Recommended temperatures are optimal for stain removal performance; adjust temperature selection to suit load being washed.
- Ensure stain is completely removed after wash cycle and before placing in dryer; very tough stains may require a second treatment.

# Getting started

## F Cycle Options - Continued

### Deep Fill

Select the **Deep Fill** feature for loads where extra water is needed. The **Deep Fill** feature is recommended for special case loads only, not for typical use.

Press the **Deep Fill** button once before starting the cycle to add an incremental amount of water to the wash load. Holding the **Deep Fill** button for 3 seconds will provide the deepest fill level possible; this will increase cycle time due to the additional time it takes to fill the washer.

To cancel the option if desired, press the **Deep Fill** button again.

**NOTE:** The **Deep Fill** button can also be pressed after the washer has completed filling and is in the wash phase if additional water is desired. To stop the extra fill, press the **Deep Fill** button again and the water will stop.

### Auto Soak

This option begins with a brief agitation, soaks for a specified period of time, then moves through the rest of the cycle automatically.

### 2nd Rinse

When you use extra detergent or bleach to clean heavily soiled clothes, use the **2nd Rinse** option to better remove additional residues.

### Extra Spin

Select to provide additional spin time, increasing energy efficiency through reducing drying times.

### 2nd Rinse + Extra Spin

Provides both a second rinse and an extra spin.

### Deep Rinse/Extra Rinse

Set this option to provide a deep rinse or when using fabric softener. This option may change other settings (e.g. **Spin** may go to a higher setting) to maximize performance.

**NOTE:** For models GTW340, GTW490 and GTW500 only. If liquid fabric softener is desired, wait until the **Rinse** cycle status light is lit and the final rinse fill is complete before adding the recommended amount of liquid fabric softener directly to the rinse bath. When adding liquid fabric softener, pour into deeper areas of rinse water while avoiding direct contact with fabric.

## Consumer Help Indicator

Your washer is equipped with Consumer Help Indicator (CHI). CHI is our way to communicate a simple remedy for some situations that you can perform without the need to call for service. The chart below describes the helpful lights you may notice flashing on the display.

<b>Spin</b> light blinking	If an out-of-balance condition is detected by the washer, the <b>Spin</b> light will blink during the remaining portion of the cycle and will stay illuminated for a short time after cycle completion. When this occurs, the washer is taking actions to correct the out-of-balance condition and complete the cycle normally. In some cases, the washer may not be able to balance the load and spin up to full speed. If you notice the load is more wet than normal at the end of the cycle, redistribute the load evenly in the wash basket and run a <b>Drain &amp; Spin</b> cycle.
<b>Fill</b> light (Water not entering washer)	Check your house water supply. Did you forget to turn on one or both supply valves after installation or coming back from vacation? As soon as the light starts to flash, the washer will initiate a 4 minute lock-out period. The washer controls won't respond/change during this time. After the 4 minutes, you can begin your cycle again. If you try to bypass the lock-out period by unplugging the washer, the 4 minute timer will start over again.
<b>Lid Locked</b> light	<b>Lid Locked</b> light will flash if 3 cycles have been started without opening the lid. The washer will not start another cycle until the lid is opened. Try opening, then closing the lid and starting a new cycle. If the problem persists, call GE Appliances at 800.GE.CARES (800.432.2737) for service.

# Getting started

## Automatic Load Sensing

This determines the correct agitate profile, agitate duration and amount of water suited to the size and type of load placed in the washer. The washer will not start the wash cycle or fill with water if the lid is open. When the lid is closed the machine is able to begin filling with water in order to sense the load size.

**NOTE: Automatic Load Sensing** initiates a spin at the beginning of the cycle and will take as much as 3 minutes to complete (significantly shorter for smaller loads); this is normal operation.

**NOTE:** This is a high efficiency washing machine. This system requires less water while providing effective cleaning action. You may notice that the water level is lower than on your previous washer. This is normal.

## Liquid Fabric Softener Dispenser (on some models)

The **agitator cap** fits into the top of the agitator. If it accidentally comes off, simply put it back on.

The **fabric softener dispenser** automatically releases liquid fabric softener at the proper time during the cycle.

**Do not stop the washer or raise the lid during the first spin. This will cause the dispenser to empty too soon.**

To use, follow these steps:

- 1 Make sure dispenser is securely attached to agitator.

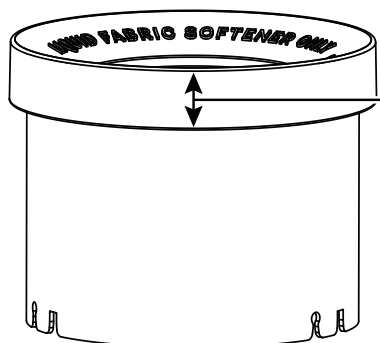
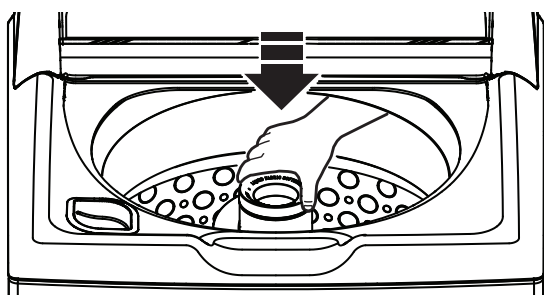

ONLY this portion of the dispenser is visible once installed into agitator

- 2 Use only liquid diluted fabric softener. Pour into dispenser, using amount recommended on package.

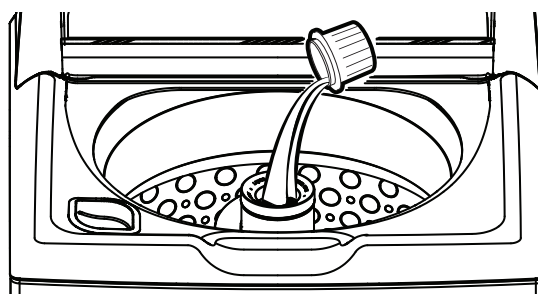

**Never pour fabric softener directly on clothes. It may stain them.**

- 3 Add water to dispenser until it reaches the maximum fill line.

Do not pour anything into the agitator if the agitator cap or dispenser is removed.



- 4 Select **Deep Rinse/Extra Rinse** option.

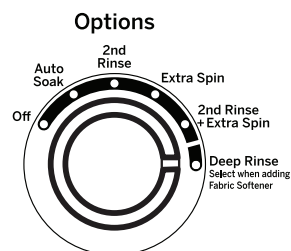

**NOTE:** Fabric softener may not dispense properly if the **Deep Rinse/Extra Rinse** option is not selected.

## Liquid Bleach

Liquid chlorine bleach should be added through the bleach dispenser in the **front left corner**. Follow bleach manufacturer's recommendations for the correct amount of liquid chlorine bleach based on load size, taking care to not apply or spill it directly on clothing.

**NOTE:** Do not use liquid chlorine bleach and laundry pretreatments such as an Oxi product in the same wash load.

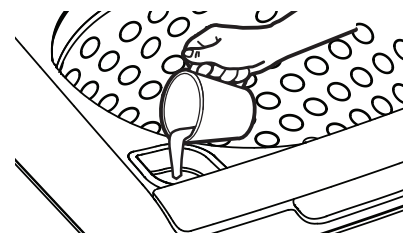

## Pretreatment

Place laundry pretreatments, such as an Oxi product, directly in the bottom of the wash basket before loading clothes.

**NOTE:** Do not use liquid chlorine bleach and laundry pretreatments such as an Oxi product in the same wash load.



# Loading

Always follow fabric manufacturer's care label when laundering.

## Proper Use of Detergent

Using too little or too much detergent is a common cause of laundry problems.

Use less detergent if you have soft water, a smaller load or a lightly soiled load.

For spots, apply pre-treatment to items as recommended on the product label. Application should be made in the basket to prevent overspray which may cause the coloring on the lid or graphics to fade.

Place detergent packets in the bottom of the wash basket before adding clothes.

GE Appliances recommends the use of High Efficiency detergents such as  in your energy efficient washer. HE detergents are formulated to work with low water wash and rinse systems. HE detergents reduce the oversudsing problems commonly associated with regular detergents.

When using high efficiency or concentrated detergents, consult the product label to determine amount required for optimum performance. Excessive detergent will negatively impact wash performance.

## Sorting Wash Loads

Sort by color (whites, lights, colors), soil level, fabric type (sturdy cottons, easy care, delicates) and whether the fabric produces lint (terry cloth, chenille) or collects lint (velveteen, corduroy). Wash lint producers such as cotton towels and socks separate from lint collectors including synthetic garments and dress pants.

### **⚠ WARNING** - Fire Hazard

**DO NOT** wash fabrics soiled with flammable liquids or cleaning solvents.

No washer can completely remove oil.

**DO NOT** dry anything that has been soaked in or spotted with any type of oil.

**DO NOT** reach into the washer until all moving parts have stopped.

Doing so can result in death, explosion, fire or amputation.

## Loading the Washer

Load dry items loosely in the washer basket. For best results, load items evenly and loosely around the outside of the basket, filling in towards the center on larger loads. To add items after washer has started, press **Start/Pause** if the lid is locked; wait until the **Lid Lock** indicator on the display is no longer illuminated before attempting to open the lid. Lift the lid and submerge additional items around the outside of the basket. Close the lid and press **Start** to resume. Adjust load size selection and/or use **Deep Fill** option if necessary.

- On Infusor models, do not place large items such as sheets, blankets and towels across the Infusor. Load them around the outside of the basket.
- Do not put lawn or sofa cushions into the washer as they are too big to move. Remove outer covers and **ONLY** wash them.

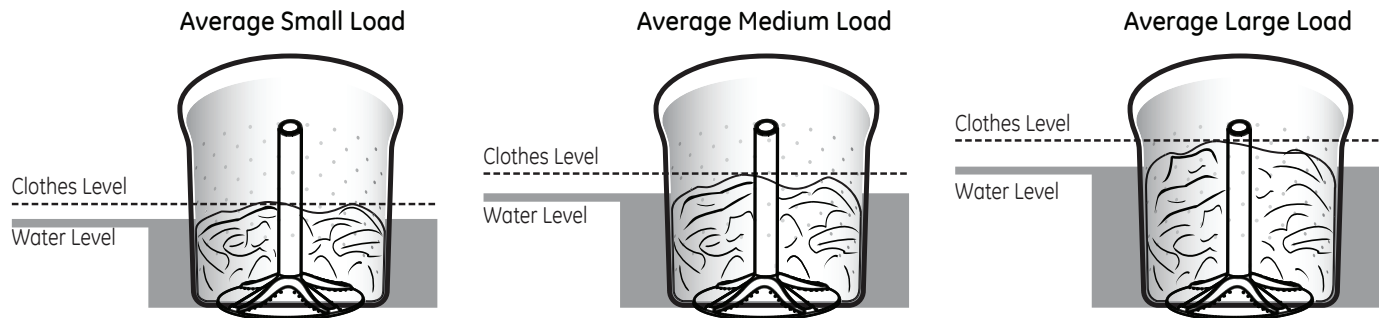

# Appliance communication

---

## WiFi Connect (For customers in the United States only - on some models)

Your washer may be **GE Appliances WiFi Connect** compatible using the optional **GE Appliances ConnectPlus** module.

**If compatible:** To connect this appliance to the internet you will need to purchase a **GE Appliances ConnectPlus** and attach the module to your appliance through the communication port in the appliance. The **GE Appliances ConnectPlus** will allow your appliance to communicate with your smartphone for remote appliance monitoring, control and notifications.

**WiFi Connectivity:** For assistance with the appliance or the **GE Appliances ConnectPlus** network connectivity, please call GE Appliances Connected Home Support at **800.220.6899**.

Please visit [www.GEAppliances.com/connect](http://www.GEAppliances.com/connect) to learn more about connected appliance features, to learn what connected appliance apps will work with your smartphone and to learn where you can purchase a **ConnectPlus** module.

The **ConnectPlus** module has the FCC/IC ID located on the back of the module.

<b>Part Number</b>	<b>Accessory</b>
<b>PBX10W00Y0</b>	<b>WiFi ConnectPlus</b> module



# Care and cleaning

## **⚠ WARNING** - Electrical Shock Hazard

Certain internal parts are intentionally not grounded and may present a risk of electric shock only during servicing. **Service personnel – DO NOT** contact the following parts while the appliance is energized: Drive Motor, Lid Lock, Water Valves, Drain Pump and Recirculation Pump.

## Exterior of the Washer

Immediately wipe off any spills with a damp cloth.

## Interior of the Washer

Leave the lid open after washing to allow moisture to evaporate. If you want to clean the basket, use a clean soft cloth dampened with liquid detergent; then rinse. (Do not use harsh or gritty cleaners.)

## Cleaning the Fabric Softener Dispenser (on some models)

- 1 Remove the dispenser from the top of the agitator.
- 2 Separate the dispenser cup from the cover by grasping the top and pushing down on the inside of the cup with your fingers. Dispenser cup will pop free from the cover.
- 3 To clean the dispenser, soak both the dispenser cup and the dispenser cover in the following solution:
  - 1 US gallon (3.8 liters) warm water
  - 1/4 cup (60 ml) heavy-duty liquid detergent
  - 1 cup (240 ml) bleach
- 4 If necessary, loosen buildup with a clean, soft cloth after soaking. Do not use a stiff brush; you may roughen the surface of the dispenser.
- 5 Rinse and reassemble dispenser. Place dispenser back on the agitator.

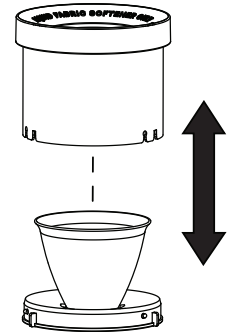

Separate for cleaning

## Water Supply Hoses

Hoses connecting washer to faucet should be replaced every 5 years.

## Moving and Storage

Ask the service technician to remove water from drain pump and hoses. Do not store the washer where it will be exposed to the weather.

## Long Vacations

Be sure water supply is shut off at faucets. Drain all water from hoses and water filter pump area if weather will be below freezing.

# Installation Instructions

# Washer

If you have any questions, call GE Appliances at 800.GE.CARES (800.432.2737) or visit our Website at: [GEAppliances.com](http://GEAppliances.com)  
In Canada, call 800.561.3344 or visit [www.GEAppliances.ca](http://www.GEAppliances.ca)

## BEFORE YOU BEGIN

Read these instructions completely and carefully.

- **IMPORTANT** – Save these instructions for local inspector's use.
- **IMPORTANT** – Observe all governing codes and ordinances.
- **Note to Installer** – Be sure to leave these instructions with the Consumer.
- **Note to Consumer** – Keep these instructions for future reference.
- **Skill level** – Installation of this appliance requires basic mechanical and electrical skills.
- **Completion time** – 1-3 hours
- Proper installation is the responsibility of the installer.
- Product failure due to improper installation is not covered under the Warranty.

## PARTS SUPPLIED

- Drain Hose
- Owner's Reference Guide



- Cable Tie
- Drain Hose Clip



- Clamp

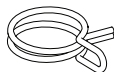

## TOOLS REQUIRED FOR WASHER INSTALLATION

- Pliers



- Level



## PARTS REQUIRED (Sold separately)

- Water Hoses (2)

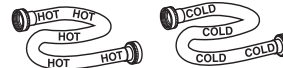

- Rubber Washers (2) and Strainer Screens (2)



- Drain Hose Extension (For discharge heights from 60" - 96")

### GE Appliances Parts and Accessories

Order on-line at [GEApplianceparts.com](http://GEApplianceparts.com) today, 24 hours a day or by phone at 800.626.2002 during normal business hours.

Part Number	Accessory
PM14X10002	4 ft Rubber Water Supply Hoses
Or	
PM14X10005	4 ft Braided Metal Water Supply Hoses
WH1X2267	Rubber Washer (1) and Screen (1)
WH49X301	Drain Hose Extension (For discharge heights from 60" - 96")

**NOTE:** We strongly recommend the use of new water supply hoses. Hoses degrade over time and need to be replaced every 5 years to reduce the risk of hose failures and water damage.

# Installation Instructions

## LOCATION OF YOUR WASHER

### DO NOT Install the Washer:

1. In an area exposed to dripping water or outside weather conditions. The ambient temperature should never be freezing or near freezing for proper washer operation.
2. In an area where it will come in contact with curtains or drapes.
3. On carpet. The floor **MUST** be a hard surface with a maximum slope of 1/2" per foot (1.27 cm per 30 cm). To make sure the washer does not vibrate or move, you may have to reinforce the floor.

**NOTE:** If floor is in poor condition, use 3/4" impregnated plywood sheet solidly attached to existing floor covering.

## IMPORTANT: Minimum Installation Clearances - Alcove or Closet

- If your washer is approved for installation in an alcove or closet, there will be a label on the back of the machine describing requirements.
- Minimum clearance between washer and adjacent walls or other surfaces: 0" either side, 2" front, 3" rear. Vertical space from floor to overhead shelving, cabinets, ceiling, etc. = 60".
- Closet doors must be louvered or otherwise ventilated and have at least 60 square inches of open area. If the closet contains both a washer and a dryer, doors must contain a minimum of 120 square inches of open area.

**NOTE:** The clearances stated on this label are minimums. Consideration must be given to providing adequate clearances for installing and servicing.

## WATER SUPPLY REQUIREMENTS

**WATER SUPPLY LINES** - Purge Hot and Cold water supply lines for 30 seconds prior to installation of hoses and washing machine. Ensure inlet hose screens are also clean and free of debris.

**WATER PRESSURE** - Must be 20 psi minimum to 120 psi maximum.

**WATER TEMPERATURE** - Household water heater should be set to deliver water at 120° to 150°F (50° to 66°C) TO THE WASHER when hot wash is selected.

**SHUTOFF VALVES** - Both hot and cold shutoff valves (faucets) should be supplied.

**DRAIN** - Water should be drained into standpipe. Discharge height **MUST NOT BE LESS THAN 30 INCHES**, and no more than 8 feet above the base of the washer. Standpipe must be 1-1/2 inches minimum inside diameter and must be open to atmosphere.

## 1 UNPACKING THE WASHER

After the machine is in the home, remove outside packing material/carton from washer.

Remove bag (containing clamp, cable tie and drain hose clip), drain hose and Owner's Reference Guide from tub.

**NOTE:** Leave foam shipping material inside tub opening to hold tub in place during the rest of installation.

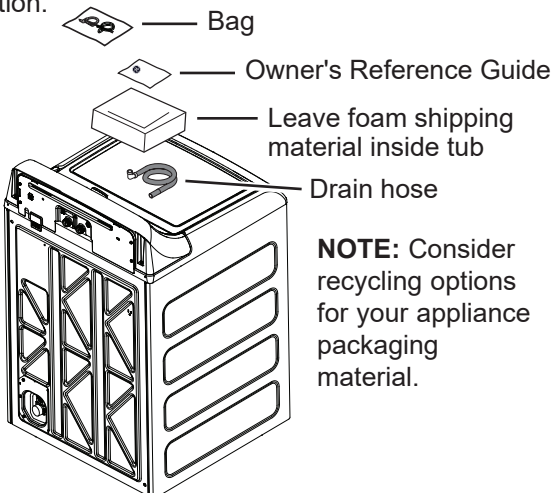

**NOTE:** Consider recycling options for your appliance packaging material.

## 2 REMOVE THE BASE

Remove base from unit by placing foot on side of base and tipping unit back on corner post. Remove base and bring the washer back upright.

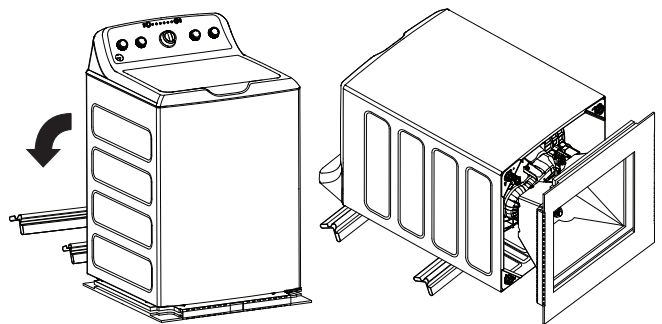

### ⚠ WARNING - Electrical Shock Hazard

Certain internal parts are intentionally not grounded and may present a risk of electric shock only during servicing.

**Service personnel – DO NOT** contact the following parts while the appliance is energized: Drive Motor, Lid Lock, Water Valves, Drain Pump and Recirculation Pump.

# Installation Instructions

## 3 CONNECT DRAIN HOSE TO WASHER

Remove the cap from the drain port, if present, before installing the drain hose. It is normal for a small amount of residual water from the factory quality test process to drain out of the port when removing the cap.

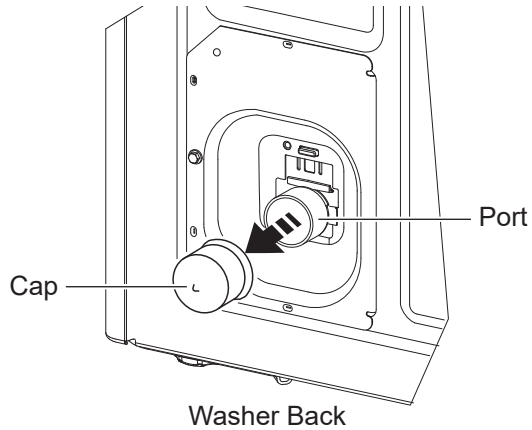

Connect drain hose to drain port on back of washer. Open clamp with pliers and slide onto hose end. Holding clamp open, push hose end onto drain port until fully seated. Release clamp between locating ribs on hose end. Outlet of hose end should be oriented vertically.

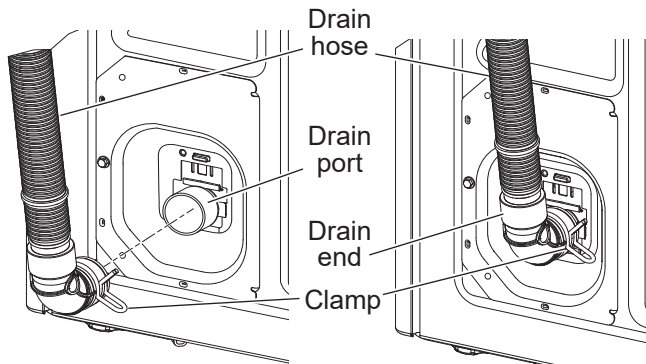

## 4 CONNECT WATER HOSES TO WASHER

Unplug electrical cord before installing water hoses. If not installed, install rubber washer in one end of hot water hose. Thread hot water hose onto connection labeled **H** at top rear of washer. Hand tighten and use pliers to tighten hoses between 1/8 and 1/4 turn beyond hand-tight.

If not installed, install rubber washer in one end of cold water hose. Thread cold water hose onto connection labeled **C** at top rear of washer. Hand tighten and use pliers to tighten hoses between 1/8 and 1/4 turn beyond hand-tight.

Move washer as close to final location as possible, leaving room for you to make water, drain, and electrical connections to your home.

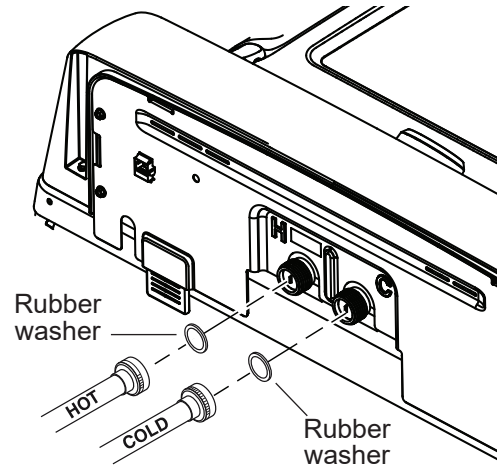

## 5 CONNECT WATER HOSES TO OUTLET VALVES

Determine which is HOT water line before attaching water hoses to faucets. Traditionally, HOT faucet is on left.

(If screen washers are not installed) With protruding part of screen toward you, install strainer screen/rubber washer into each of the free ends of two water hoses.

Connect hot water hose to hot water outlet valve of your home. Hand tighten and use pliers to tighten hoses between 1/4 and 1/2 turn beyond hand-tight. Open hot water valve.

Connect cold water hose to cold water outlet valve of your home. Hand tighten and use pliers to tighten hoses between 1/4 and 1/2 turn beyond hand-tight. Open cold water valve.

Check for leaks and drips at the hose couplings. Tighten as necessary.

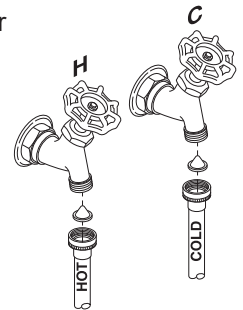

# Installation Instructions

## 6 CONNECT TO DRAIN

Install drain hose clip on rear panel of washer. Route drain hose through clip and insert free end into drain opening of your home.

**NOTE: If longer drain hose is required, order drain hose extension kit, GE Appliances part number WH49X301. Connect additional drain hose (contained in kit) to original hose with hose clamp (contained in kit).**

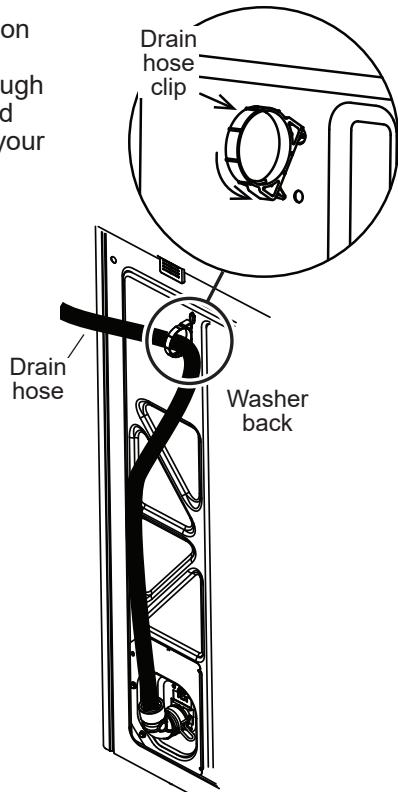

If water valves and drain are built into wall, fasten drain hose to one of the water hoses with cable tie provided.

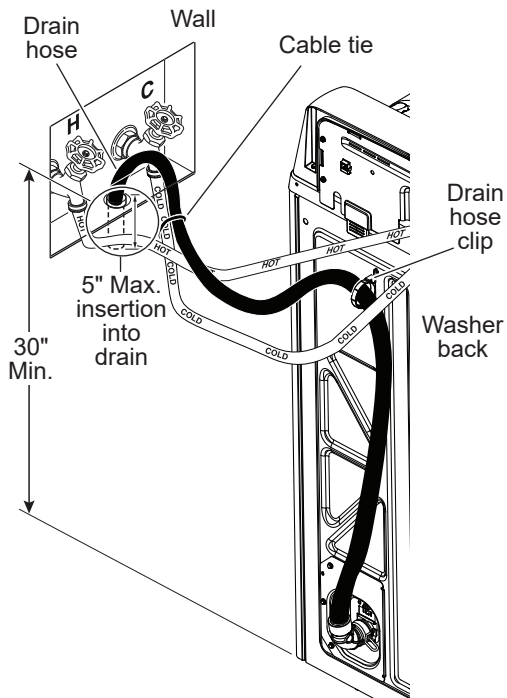

**NOTE: Placing the drain hose too far down the drain pipe can cause a siphoning action. No more than 5" of hose should be in the drain pipe. There must be an air gap around the drain hose. A snug fit can also cause a siphoning action.**

## 6 CONNECT TO DRAIN (Continued)

If your drain is a standpipe, fasten drain hose to standpipe with cable tie provided.

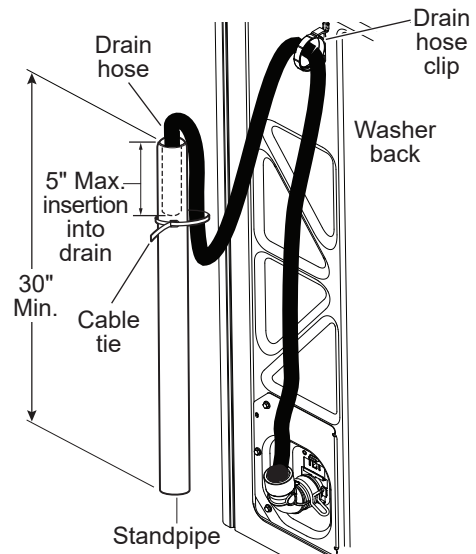

**NOTE: Placing the drain hose too far down the drain pipe can cause a siphoning action. No more than 5" of hose should be in the drain pipe. There must be an air gap around the drain hose. A snug fit can also cause a siphoning action.**

If drain discharge height does not meet 30" minimum height requirement, end of drain hose must be secured in drain opening of home by installer and have an air gap around hose to prevent siphoning.

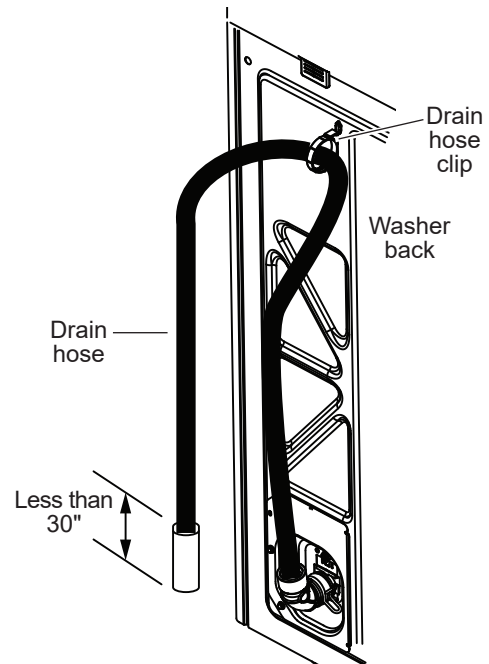

**NOTE: Placing the drain hose too far down the drain pipe can cause a siphoning action. No more than 5" of hose should be in the drain pipe. There must be an air gap around the drain hose. A snug fit can also cause a siphoning action.**



# Installation Instructions

## ELECTRICAL REQUIREMENTS

### **⚠ WARNING** - Electrical Shock Hazard

Plug into a grounded 3-prong outlet.

**DO NOT** remove ground prong.

**DO NOT** use an adapter.

**DO NOT** use an extension cord.

Failure to follow these instructions can result in death, fire or electrical shock.

**CIRCUIT** – Individual, properly polarized and grounded 15 or 20 amp circuit breaker or time-delay fuse.

**POWER SUPPLY** – 2 wire plus ground, 120 Volt, single phase, 60 Hz, alternating current.

**Outlet Receptacle** – Properly grounded 3-prong receptacle to be located so the power cord is accessible when the washer is in an installed position. If a 2-prong receptacle is present, it is the owner's responsibility to have a licensed electrician replace it with a properly grounded 3-prong grounding type receptacle.

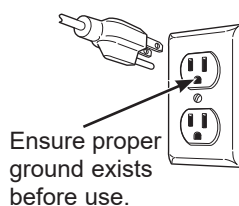

Washer must be electrically grounded in accordance with local codes and ordinances, or in the absence of local codes, with latest edition of the NATIONAL ELECTRICAL CODE, ANSI/NFPA NO. 70 or CANADIAN ELECTRICAL CODE, CSA C22.1. Check with a licensed electrician if you are not sure that the washer is properly grounded.

## **7** CONNECT POWER AND INSTALL

Make sure large dial control (on some models) on washer is pushed in to the OFF position.

Insert plug of electrical cord into a 115V, 15- or 20-amp wall receptacle. Move washer into final position. Place level on flat top side edges of washer. Adjust all four leveling legs until washer is level left-to-right and front-to-back. Remove level.

Open tub lid. Remove and discard tub shipping material (see Step 1).

Remove plastic protector sheet from control panel face.

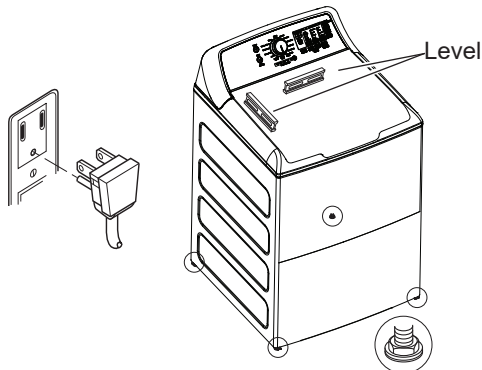

## GROUNDING INSTRUCTIONS

This appliance must be grounded. In the event of malfunction or breakdown, grounding will reduce the risk of electric shock by providing a path of least resistance for electric current. This appliance is equipped with a cord having an equipment-grounding conductor and a grounding plug. The plug must be plugged into an appropriate outlet that is properly installed and grounded in accordance with all local codes and ordinances.

**⚠ WARNING** Improper connection of the equipment-grounding conductor can result in a risk of electrical shock. Check with a qualified electrician, or service representative or personnel, if you are in doubt as to whether the appliance is properly grounded. **DO NOT** modify the plug on the power supply cord. If it will not fit the outlet, have a proper outlet installed by a qualified electrician.

If required by local codes, an external 18 gauge or larger copper ground wire (not provided) may be added. Attach to washer cabinet with a #10-16 x 1/2" sheet metal screw (available at any hardware store) to rear of washer as illustrated.

Attach ground wire and ground screw (obtain locally)

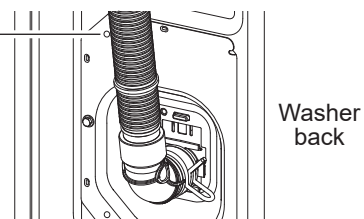

### **Mobile Home Installation:**

Installation must conform to Standard for Mobile Homes, ANSI A119.1 and National Mobile Home Construction and Safety Standards Act of 1974 (PL93-383).

## FINAL CHECKLIST



### **Before starting the washer, check to make sure:**

- Main power is turned on.
- The washer is plugged in.
- The water faucets are turned on.
- The unit is level and all four leveling legs are firmly on the floor.
- The shipping foam and cardboard are removed.
- The drain hose is properly tied up.
- There are no leaks at the faucet, drain line or washer.
- Remove the cap from the drain port, if present, before installing the drain hose.

### **Run the washer through a complete cycle.**

- Check for water leaks and proper operation.
- Place these instructions in a location near the washer for future reference.

# Troubleshooting Tips... Before you call for service

Problem	Possible Causes	What To Do
Short spray and delay after pushing the Start button	Lid was opened and closed between cycle selection and start	This is normal. See START-UP SEQUENCE in the <b>Safety Instructions</b> section.
Water level seems low	This is normal	Water may not cover the top level of the clothes. This is normal for this high efficiency washer.
Low water flow	Water valve screens are stopped up	Turn off the water source and remove the water connection hoses from the upper back of the washer and the water faucets. Clean both the hose screens (if so equipped) and the screens in the machine using a brush or a toothpick. Reconnect the hoses and turn the water back on. Check to ensure there are no leaks at the connections.
Water siphoning out of washer	Drain standpipe is too low or hose too far into standpipe	The drain hose must exceed 30" height at some point between the washer back and the drain pipe. Use anti-siphon clip. See the <b>Installation Instructions</b> .
Too many suds	Soft water	Try less detergent.
	Too much detergent	Measure your detergent carefully. Use less soap if you have soft water, a smaller load or a lightly soiled load.
	Type of detergent	Switch to High Efficiency detergent such as 
Water leaks	Type of detergent	Switch to High Efficiency detergent such as 
	Using too much detergent in washer	Use less detergent. Use less soap if you have soft water, a smaller load or a lightly soiled load.
	Fill hoses or drain hose is improperly connected	Make sure hose connections are tight at faucets and rubber washers are installed. Make sure end of drain hose is correctly inserted in and secured to drain facility.
	Household drain clogged	Check household plumbing. You may need to call a plumber.
	Drain hose rubs on wall	Make sure drain hose does not make contact with the wall. May cause excessive wear on the hose.
	Constant water pressure to fill hoses at water source	Tighten hoses at the faucets. Check condition of the fill hoses; they should be replaced every 5 years.
Water temperature seems incorrect	Cooler water temperatures provide improved energy efficiency	New laundry detergents have been formulated to work with cooler water temperatures without affecting wash performance.
	Water supply is turned off or improperly connected	Turn both hot and cold faucets fully on and make sure hoses are connected to correct faucets. <b>NOTE:</b> Water valves are marked "H" and "C".
	Water valve screens are stopped up	Turn off the water source and remove the water connection hoses from the upper back of the washer and the water faucets. Clean both the hose screens (if so equipped) and the screens in the machine using a brush or a toothpick. Reconnect the hoses and turn the water back on. Check to ensure there are no leaks at the connections.
	Cool/Cold Water when selecting Hot	This is normal. The washer senses water temperature (on some models) and optimizes for best results. Cold water is added periodically when hot is selected.
	House water heater is not set properly	Make sure house water heater is delivering water at 120°F–140°F (48°C–60°C).
Water pumped out before cycle is complete	Water was left in unit for 24 hours with lid closed or 15 minutes with lid open	Previous cycle has been cancelled. Close lid, select new cycle, and start machine.
Water won't drain	Drain hose is kinked or improperly connected	Straighten drain hose and make sure washer is not sitting on it. Top of drain outlet should be less than 8 ft (2.44 m) above floor.

## Troubleshooting Tips... Before you call for service

Problem	Possible Causes	What To Do
Washer spins and pauses at the beginning of cycles	This is normal	The washer is sensing the load.
Washer pauses during wash cycle	The Soak Option was chosen	This is normal. The washer alternates between agitate and soak during these cycles to get your clothes cleaner with less wear.
	This is normal	Many cycles incorporate a series of soaks within the agitation period to get your clothes clean with less wear.
Laundry additives dispensing too soon (Dispensers on some models)	Overfilling of dispensers	Do not overfill or add water to dispenser. Select <b>Deep Rinse/Extra Rinse</b> option when using fabric softener.
Washer pauses during spin cycle	This is normal	The washer may pause during the spin cycle to remove soapy water more efficiently.
Washer won't operate	Washer is unplugged	Make sure cord is plugged securely into a working outlet.
	Water supply is turned off	Turn both hot and cold faucets fully on.
	Lid is open—safety feature prevents agitation and spinning when lid is up	Close lid and press <b>Start</b> .
	Circuit breaker/fuse is tripped/blown	Check house circuit breakers/fuses. Replace fuses or reset breaker. Washer should have a separate outlet.
	Electronics need to be reset	Unplug washer, wait 2 minutes, plug back in and press <b>Start</b> .
	Start was not pressed	Press <b>Start</b> .
Detergent packets not dissolving	Laundry detergent packet placed in dispenser	Laundry detergent packets should not be used in the dispensers. They should only be added directly to the wash basket following the manufacturer's directions.
Unexplained time and/or settings changes	Changing options (on some models)	This is normal. Several options will change other options to maximize washer performance.
Basket seems loose	Basket moves or rotates freely	Washer basket does not have a traditional brake. Washer basket will move freely. This is normal.
Agitator seems loose (on some models)	Agitator top moves/has side-to-side movement	Agitator top is designed to be flexible to allow for care of large bulky items such as comforters; this is normal.
Colored spots	Incorrect use of fabric softener	Check fabric softener package for instructions and follow directions for using dispenser. Make sure you have selected the <b>Deep Rinse/Extra Rinse</b> option. (on some models) Pretreat stain and rewash using <b>Speed Wash</b> cycle before drying. (on some models)
	Dye transfer	Sort whites or lightly colored items from dark colors.
Grayed or yellowed clothes	Detergent amount	Be sure to follow detergent manufacturer's directions.
	Hard water	Use a water conditioner or install a water softener.
	Water is not hot enough	Make sure water heater is delivering water at 120°F–140°F (48°C–60°C).
	Washer is overloaded	Loosely load clothes no higher than the top row of holes in the washer basket. For best results, load items around the outside of the basket.
	Dye transfer	Sort clothes by color. If fabric label states wash separately, unstable dyes may be indicated.



# Troubleshooting Tips... Before you call for service

Problem	Possible Causes	What To Do
Lint or residue on clothes	<b>Clothes are air or line dried</b>	If you do not dry your clothes with a clothes dryer, your clothes may retain more lint.
	<b>Incorrect sorting</b>	Separate lint producers from lint collectors.
	<b>Washing too long</b>	Wash small loads for a shorter time using Light <b>Soil</b> setting.
	<b>Detergent not dissolving</b>	Rewash; next time: Try a liquid detergent Use warmer water temperature.
	<b>Overloading</b>	Loosely load clothes in the washer basket. For best results, load items around the outside of the basket.
	<b>Incorrect use of fabric softener</b>	Check fabric softener package for instructions and follow directions for using dispenser. Make sure you have selected the <b>Deep Rinse/Extra Rinse</b> option. (on some models)
Clothes too wet	<b>Incorrect cycle selected</b>	Make sure the cycle selected matches the load you are washing. Some fabrics will feel wetter when rinsed with cold water.
	<b>Wash load out of balance</b>	Redistribute load in washer and run through <b>Drain &amp; Spin</b> cycle.
<b>Blinking Spin light or Spin light on at end of cycle</b>	<b>Out of balance condition has been detected</b>	Allow cycle to continue and finish. If load is wet at the end of the cycle, even out load and run a <b>Drain &amp; Spin</b> cycle.
<b>Pilling</b>	<b>Result of normal wear on poly-cotton blends and fuzzy fabrics</b>	While this is not caused by the washer, you can slow the pilling process by washing garments inside out.
Snags, holes, tears, rips or excessive wear	<b>Pins, snaps, hooks, sharp buttons, belt buckles, zippers and sharp objects left in pockets</b>	Fasten snaps, hooks, buttons and zippers. Remove loose items like pins, objects in pockets and sharp buttons. Turn knits (which snag easily) inside out.
	<b>Undiluted chlorine bleach</b>	Check bleach package instructions for proper amount. Never add undiluted bleach to wash or allow clothes to come in contact with undiluted bleach.
	<b>Chemicals like hair bleach or dye, permanent wave solution</b>	Rinse items that may have chemicals on them before washing. Use <b>Speed Wash</b> cycle with <b>Extra Rinse</b> option. (on some models)
Wrinkling	<b>Incorrect wash and dry cycles</b>	Match Cycle selection to the type of fabric you are washing (especially for easy care loads).
	<b>Improper sorting</b>	Avoid mixing heavy items (like jeans) with light items (like blouses). Try a fabric softener.
	<b>Overloading</b>	Loosely load clothes in the washer basket.
	<b>Repeated washing in water that is too hot</b>	Wash in warm or cold water.

## Troubleshooting Tips... Before you call for service

Sounds	Possible Causes	Reason
“Clicking”	<b>Shifter mechanism is engaging or disengaging</b>	The drive system will engage at the start of agitate and disengage when agitate is complete. This occurs multiple times during the wash.
Back and forth “swoosh”	<b>Electric motor reversing direction</b>	This sound is the motor rotating back and forth to clean your laundry.
“Clicking” behind Control during fill	<b>Automatic Temperature Control Valve</b>	Two valves mix cold and hot water. The “clicking” is when either valve turns on or off to raise or lower the fill water temperature.
Water flow changes during fill	<b>Automatic Temperature Control Valve</b>	Two valves mix cold and hot water. The “clicking” is when either valve turns on or off to raise or lower the fill water temperature.
Motor sounds during spin	<b>Motor ramping up/down during spin cycle</b>	The motor will speed up incrementally during the spin cycle. When spin is complete, it will coast until it stops.
“Humming”	<b>Water drain pump</b>	The drain pump will make a humming sound when pumping out water after agitation stops and continue until spin is complete.
	<b>Drive motor</b>	The drive motor will make a “humming” sound during the wash and spin phases of the cycle.
“Gurgling”	<b>Water drain pump</b>	When the pump starts drawing in air, it starts to gurgle. The washer should then begin spinning and the sound will continue until it is done spinning.
Water “swishing”	<b>Washing process</b>	Water swishing while the unit is agitating is normal, especially with smaller loads.
Washer rocking/moving	<b>Washer leveling legs uneven</b>	To level the washer, adjust the leveling legs by rotating the individual leg in the proper direction for up or down.
“Squeaking” sound	<b>Washer not level and rubbing on cabinet</b>	To level the washer, adjust the leveling legs by rotating the individual leg in the proper direction for up or down.

### Washer sounds that may be different from your prior washer:

Clicks, water flowing, gear sounds followed by pauses, and electric hum sounds are all part of the normal wash cycle.

To listen and watch videos of normal washer operation, please go to <http://products.geappliances.com/appliance/gea-support-search-content?contentid=23061> or scan the QR code.



# GE Appliances/Hotpoint Washer Limited Warranty

**LIMITED WARRANTY**

## GEAppliances.com

All warranty service is provided by our Factory Service Centers, or an authorized Customer Care® technician. To schedule service online, visit us at [GEAppliances.com/service](http://GEAppliances.com/service), or call GE Appliances at 800.GE.CARES (800.432.2737). Please have your serial number and your model number available when calling for service.

Servicing your appliance may require the use of the onboard data port for diagnostics. This gives a GE Appliances factory service technician the ability to quickly diagnose any issues with your appliance and helps GE Appliances improve its products by providing GE Appliances with information on your appliance. If you do not want your appliance data to be sent to GE Appliances, please advise your technician not to submit the data to GE Appliances at the time of service.

**NOTE:** For non-residential or multi-housing applications (e.g., apartment complexes, hotels, multi-family housing, etc.), the **limited warranty** is **one-year** for **any part** of the washer which fails due to a defect in materials or workmanship only. You will be responsible for any labor and related service costs.

For the period of:	We will replace:
<b>One year</b> From the date of the original purchase	<b>Any part</b> of the washer which fails due to a defect in materials or workmanship. During this <b>limited one-year warranty</b> , we will also provide, <b>free of charge</b> , all labor and related service to replace the defective part.

### Warranties for GTW525 model only:

<b>Five years</b> From the date of the original purchase	<b>Any part</b> of the washer which fails due to a defect in materials or workmanship. During this <b>limited five-year warranty</b> , we will also provide, <b>free of charge</b> , all labor and related service to replace the defective part.
<b>Ten years</b> From the date of the original purchase	<b>The motor</b> , if it should fail due to a defect in materials or workmanship. During this <b>additional nine-year limited warranty</b> , you will be responsible for any labor and related service costs.
<b>Lifetime of Product</b> From the date of the original purchase	<b>The stainless steel basket</b> , if it should fail due to rust or corrosion of the stainless steel. During this <b>additional LIFETIME limited warranty</b> , you will be responsible for any labor and related service costs.

Staple your receipt here. Proof of the original purchase date is needed to obtain service under the warranty.

### What is not covered:

- Service trips to your home to teach you how to use the product.
- Improper installation, delivery or maintenance.
- Failure of the product if it is abused, misused, or used for other than the intended purpose or used commercially.
- Replacement of house fuses or resetting of circuit breakers.
- Products which are not defective or broken, or which are working as described in the Owner's Manual.
- Damage to the product caused by accident, fire, floods or acts of God.
- Incidental or consequential damage caused by possible defects with this appliance.
- Defects or damage due to operation in freezing temperatures.
- Damage caused after delivery.
- Product not accessible to provide required service.
- Damage to the stainless steel basket caused by misuse with chemicals in non-residential or multi-housing applications.

### EXCLUSION OF IMPLIED WARRANTIES

Your sole and exclusive remedy is product repair as provided in this Limited Warranty. Any implied warranties, including the implied warranties of merchantability or fitness for a particular purpose, are limited to one year or the shortest period allowed by law.

**In the United States:** This limited warranty is extended to the original purchaser and any succeeding owner for products purchased for home use within the USA. If the product is located in an area where service by a GE Appliances Authorized Servicer is not available, you may be responsible for a trip charge or you may be required to bring the product to an Authorized GE Appliances Service location for service. In Alaska, the limited warranty excludes the cost of shipping or service calls to your home.

Some states do not allow the exclusion or limitation of incidental or consequential damages. This limited warranty gives you specific legal rights, and you may also have other rights which vary from state to state. To know what your legal rights are, consult your local or state consumer affairs office or your state's Attorney General.

**Warrantor: GE Appliances, a Haier company Louisville, KY 40225**

**In Canada:** This limited warranty is extended to the original purchaser and any succeeding owner for products purchased in Canada for home use within Canada. If the product is located in an area where service by a GE Appliances Authorized Servicer is not available, you may be responsible for a trip charge or you may be required to bring the product to an Authorized GE Appliances Service location.

Some provinces do not allow the exclusion or limitation of incidental or consequential damages. This limited warranty gives you specific legal rights, and you may also have other rights which vary from province to province. To know what your legal rights are, consult your local or provincial consumer affairs office.

**Warrantor: MC Commercial Inc., Burlington, ON, L7R 5B6**

**Extended Warranties:** Purchase a GE Appliances extended warranty and learn about special discounts that are available while your warranty is still in effect. You can purchase it online anytime at

[GEAppliances.com/extended-warranty](http://GEAppliances.com/extended-warranty)

or call 800.626.2224 during normal business hours. GE Appliances Service will still be there after your warranty expires.

# Consumer Support

---

## GE Appliances Website

Have a question or need assistance with your appliance? Try the GE Appliances Website 24 hours a day, any day of the year! You can also shop for more great GE Appliances products and take advantage of all our on-line support services designed for your convenience. [GEAppliances.com](http://GEAppliances.com).

---

## Register Your Appliance

Register your new appliance on-line at your convenience! Timely product registration will allow for enhanced communication and prompt service under the terms of your warranty, should the need arise. You may also mail in the pre-printed registration card included in the packing material. [GEAppliances.com/register](http://GEAppliances.com/register).

---

## Schedule Service

Expert GE Appliances repair service is only one step away from your door. Get on-line and schedule your service at your convenience any day of the year. [GEAppliances.com/service](http://GEAppliances.com/service) or call 800.432.2737 during normal business hours.

---

## Extended Warranties

Purchase a GE Appliances extended warranty and learn about special discounts that are available while your warranty is still in effect. You can purchase it on-line anytime. GE Appliances Services will still be there after your warranty expires. [GEAppliances.com/extended-warranty](http://GEAppliances.com/extended-warranty) or call 800.626.2224 during normal business hours.

---

## Remote Connectivity

For assistance with wireless network connectivity (for models with remote enable), visit our website at [GEAppliances.com/connect](http://GEAppliances.com/connect) or call 800.220.6899.

---

## Parts and Accessories

Individuals qualified to service their own appliances can have parts or accessories sent directly to their homes (VISA, MasterCard and Discover cards are accepted). Order on-line today 24 hours every day.

[GEApplianceparts.com](http://GEApplianceparts.com) or by phone at 877.959.8688 during normal business hours.

**Instructions contained in this manual cover procedures to be performed by any user. Other servicing generally should be referred to qualified service personnel. Caution must be exercised, since improper servicing may cause unsafe operation.**

---

## Contact Us

If you are not satisfied with the service you receive from GE Appliances, contact us on our Website with all the details including your phone number, or write to:

General Manager, Customer Relations | GE Appliances, Appliance Park | Louisville, KY 40225

[GEAppliances.com/contact](http://GEAppliances.com/contact) or call 800.626.2000.