



WASHERS

SAFETY INFORMATION 3

USING THE WASHER

Getting Started 5

Consumer Help Indicator 14

Appliance Communication 14

Loading 15

CARE AND CLEANING 16

INSTALLATION INSTRUCTIONS 18

Reversing The Door Swing (Optional)..... 23

TROUBLESHOOTING TIPS..... 27

LIMITED WARRANTY 31

CONSUMER SUPPORT 32

OWNER'S MANUAL & INSTALLATION INSTRUCTIONS

- GFW850
- GFW650
- GFW550
- GFW510
- HFV350

ENGLISH/FRANÇAIS/ESPAÑOL

Write the model and serial numbers here:

Model # _____

Serial # _____

You can find them on a label inside the washer door.

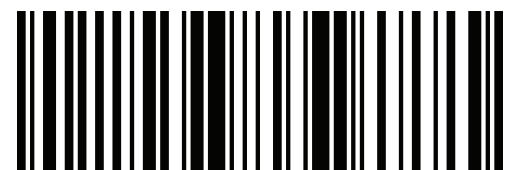

THANK YOU FOR MAKING GE APPLIANCES A PART OF YOUR HOME.

Whether you grew up with GE Appliances, or this is your first, we're happy to have you in the family.

We take pride in the craftsmanship, innovation and design that goes into every GE Appliances product, and we think you will too. Among other things, registration of your appliance ensures that we can deliver important product information and warranty details when you need them.

Register your GE appliance now online. Helpful websites and phone numbers are available in the Consumer Support section of this Owner's Manual. You may also mail in the pre-printed registration card included in the packing material.



GE APPLIANCES

IMPORTANT SAFETY INFORMATION

READ ALL INSTRUCTIONS BEFORE USING THE APPLIANCE

▲ WARNING

To reduce the risk of death, fire, explosion, electric shock, or injury to persons when using your appliance, follow basic precautions, including the following:

- Read all instructions before using the appliance.
- Follow all fabric care instructions and warnings to prevent melting of garments or damage to the appliance.
- **DO NOT** wash or dry articles that have been previously cleaned in, washed in, soaked in or spotted with gasoline, dry-cleaning solvents, or other flammable or explosive substances, as they give off vapors that could ignite or explode.
- **DO NOT** add gasoline, dry-cleaning solvents, or other flammable or explosive substances to the wash water. These substances give off vapors that could ignite or explode.
- Under certain conditions, hydrogen gas may be produced in a hot-water system that has not been used for 2 weeks or more. **HYDROGEN GAS IS EXPLOSIVE.** If the hot water system has not been used for such a period, before using a washing machine, turn on all hot-water faucets and let the water flow from each for several minutes. This will release any accumulated hydrogen gas. As the gas is flammable, **DO NOT** smoke or use an open flame during this time.
- **DO NOT** allow children to play on or in this appliance. Close supervision of children is necessary when this appliance is used near children. Before the washer is removed from service or discarded, remove the door or lid. Failure to follow these instructions may result in death or injury to persons.
- **DO NOT** reach into the appliance if the tub or agitator is moving to prevent accidental entanglement.
- **DO NOT** install or store this appliance where it will be exposed to the weather.
- **DO NOT** tamper with controls, repair or replace any part of this appliance or attempt any servicing unless specifically recommended in the user maintenance instructions or in published user repair instructions that you understand and have the skills to carry out.
- **DO NOT** climb or stand on this unit.
- **DO NOT** operate this appliance if it is damaged, malfunctioning, partially disassembled, or has missing or broken parts including a damaged cord or plug.
- Unplug the appliance or turn off the circuit breaker before servicing. Pressing the **Power** pad **DOES NOT** disconnect power.
- See “ELECTRICAL REQUIREMENTS” located in the Installation Instructions for grounding instructions.

READ AND SAVE THESE INSTRUCTIONS

IMPORTANT SAFETY INFORMATION

READ ALL INSTRUCTIONS BEFORE USING THE APPLIANCE

PROPER INSTALLATION

This washer must be properly installed and located in accordance with the Installation Instructions before it is used.

- Ensure that the hot water hose is connected to the “H” valve and the cold water hose is connected to the “C” valve.
- Install or store where it will not be exposed to temperatures below freezing or exposed to the weather, which could cause permanent damage and invalidate the warranty.
- Properly ground washer to conform with all governing codes and ordinances. Follow details in the Installation Instructions.
- Ensure washer is properly leveled and washer legs are adjusted such that unit is stable.
- Optional drain hose extension recommended for discharging heights from 60” - 96”.
- GE Appliances strongly recommends the use of factory specified parts. A list of factory hoses available for purchase are listed. These hoses are manufactured and tested to meet GE Appliances specifications.
- GE Appliances strongly recommends the use of new water supply hoses. Hoses degrade over time and need to be replaced every 5 years to reduce the risk of hose failures and water damage.

AUTOMATIC DRAIN SEQUENCE

- Machine will automatically drain any time the door is left open for more than 15 minutes and water is present.
- Machine will automatically drain if left in a paused state with the door closed for more than 24 hours and water is present.

WHEN NOT IN USE

- Turn off water faucets to minimize leakage if a break or rupture should occur. Check the condition of the fill hoses; GE Appliances recommends changing the hoses every 5 years.

PARTS AND ACCESSORIES

Order on-line at GEApplianceparts.com today, 24 hours a day or by phone at 877.959.8688 during normal business hours. In Canada, visit your local GE Appliances parts distributor or call 800.661.1616 or GEAppliances.ca/en/products/parts-filters-accessories.

Part Number	Accessory
WX14X10011	6 ft stainless steel washer hoses with 90° elbows; 2-pack
WH49X316	Washer drain hose extension kit
WX10X10011	Tide® Washing Machine Cleaner*
PM7X2	Universal low profile washer floor tray
GFA28KITN	Stack Bracket Kit (to stack dryer on top)
GFP1528S	28” width Pedestal with drawer – White
GFP1528P	28” width Pedestal with drawer – Colors
GFR0728S	28” width Riser without drawer – White
GFR0728P	28” width Riser without drawer – Colors

*Tide® is a registered trademark of Procter & Gamble

READ AND SAVE THESE INSTRUCTIONS

Getting started

⚠ WARNING To reduce the risk of fire, electric shock, or injury to persons, read the IMPORTANT SAFETY INFORMATION before operating this appliance.

Throughout this manual, features and appearance may vary from your model.

Quick Start:

Step 1

Load clothes into your washer and close the door.



Step 2

If the screen is dark, press the Power pad or turn the knob to “wake up” the display.



Step 3

Turn the knob to select the desired cycle.

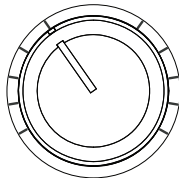

(cycle options vary by model)

Step 4

Open the dispenser and add detergent, bleach and fabric softener, as desired. Models with SmartDispense™ only require that you select the SmartDispense pad once the tank has been filled.

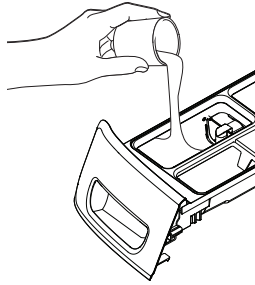

Step 5

Press Start to begin the wash cycle. The machine will weigh your clothes and add the proper amount of water. When the wash cycle is finished, the door will unlock.



Step 6 (on some models)

After the wash cycle is completed and the clothes unloaded, select **ULTRAFRESH VENT™** to help eliminate the excess moisture in your washer so you can close the door.



Display and Status Lights (Features and appearance will vary)



On some models, the display shows the approximate time remaining until the end of the cycle and the washer cycle status (**Fill, Wash, Rinse** and **Spin**).

NOTE: The cycle time is affected by how long it takes the washer to fill. This depends on the water pressure in your home. The “smart” timer “learns” the amount of time it takes to fill your washer and adjusts the total time accordingly.

On some models, if an out-of-balance condition is detected by the washer, the **Spin** status light or **Spin** option selection light will blink during the remaining portion of the cycle and will stay illuminated for a short time after cycle completion. When this occurs, the washer is taking actions to correct the out-of-balance condition and complete the cycle normally. In some cases, the washer may not be able to balance the load and spin up to full speed. If you notice the load is more wet than usual at the end of the cycle, redistribute the load evenly in the wash tub and run a **Rinse & Spin** cycle.

In addition, the display will show:

(WiFi) (on some models)	Will allow your appliance to communicate with your smartphone for remote appliance monitoring, control and notifications. It stays lit whenever the washer is on and is connected. It will blink during the commissioning process or if it loses connection to the network.
Venting (on some models)	Venting will blink to indicate that you can select the ULTRAFRESH VENT feature at the end of the cycle. It then stays illuminated once selected until venting is complete.
Control	The controls on the washer are locked when this icon is illuminated. You must press and hold the Control Lock pad to unlock the controls.
Door	This icon will illuminate while the door is locked and will blink while the washer is in the process of pausing and then unlocking.
Auto, More, Less (on some models)	The SmartDispense will automatically dose detergent according to the weight and soil level of the clothes. You can adjust this feature to dose 40% MORE or 40% LESS detergent or turn it OFF to manually dose detergent.
Tank Low (on some models)	Will display when the SmartDispense tank needs to be re-filled. Typically, this first lights up when there are approximately 8 - 10 loads of detergent remaining.
Loads Left (on some models)	Displays the estimated number of wash loads left for the amount of detergent in the SmartDispense tank.

Getting started

Features and appearance will vary.

**Model:
GFW850**

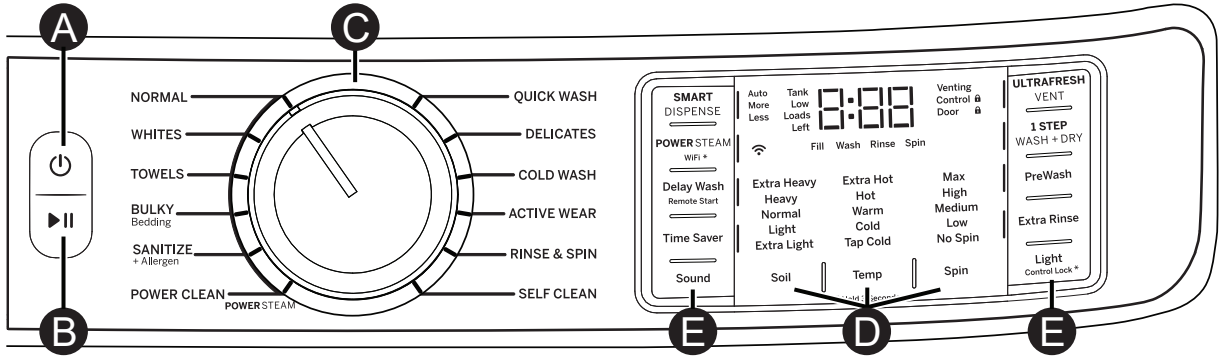

**Model:
GFW650**

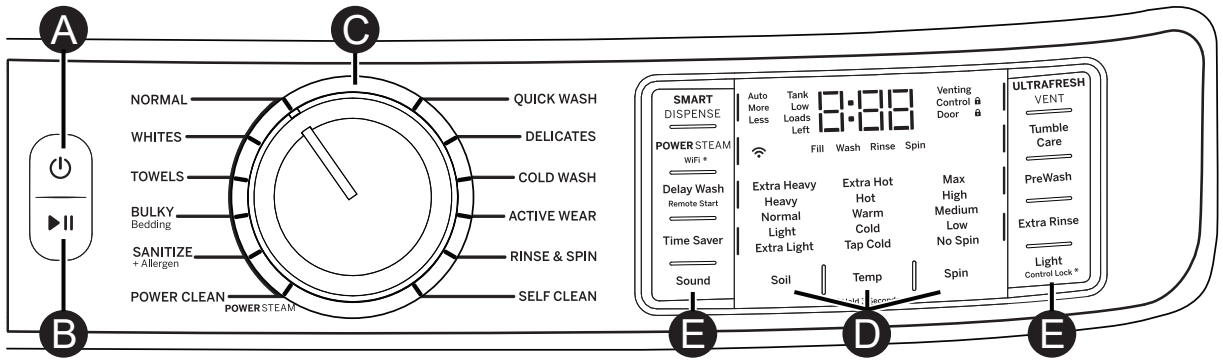

**Model:
GFW550**

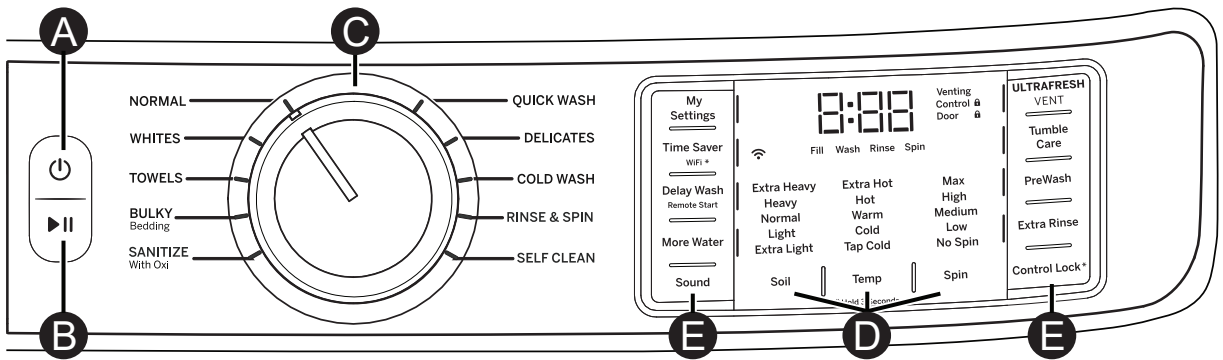

**Model:
GFW510**

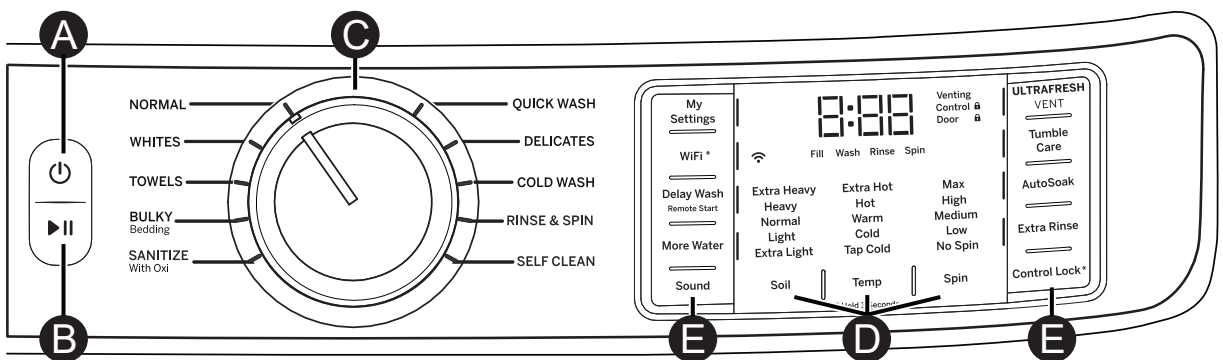

**Model:
HFW350**

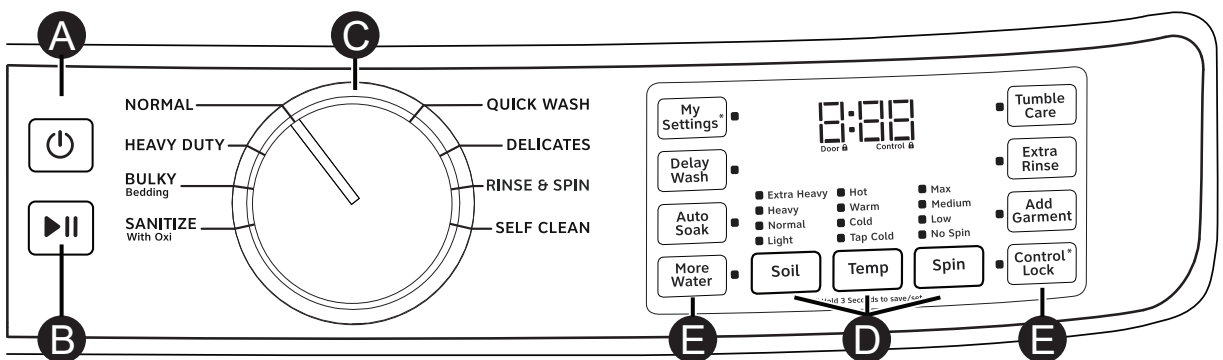

Getting started

A Power

Press to “wake up” the display. If the display is active, press to put the washer into standby “OFF” mode.

NOTE: Pressing **Power** does not disconnect the appliance from the power supply.

B Start and Pause

Press to start a wash cycle. If the washer is running, pressing it once will pause the washer and unlock the door. It will take a few seconds for the door to unlock after pressing **Pause**. Press again to restart the wash cycle.

NOTE: If washer is paused and cycle is not restarted within 15 minutes, the current wash cycle will be cancelled.

NOTE: The washer performs automatic system checks after pressing the **Start** pad. Water will flow in 45 seconds or less. You may hear the door lock and unlock and the pump activate before water flows.

C Wash Cycles

The wash cycles are optimized for specific types of wash loads. The chart below will help you match the items to be washed with the best wash cycle settings. For optimal performance, select the cycle that most closely matches the items being washed. Selections and options shown in **bold** are the suggested settings for that cycle.

Delay Wash/Remote Start is available on all cycles.

Wash Cycle	Items to Wash	Soil Level	Wash Temp	Spin Selection	Options Available
Normal	Cycle for normal, regular, or typical use for washing up to a full load of normally soiled cotton clothing.	Extra Heavy Heavy Normal Light Extra Light	Extra Hot Hot Warm Cold Tap Cold	Max High Medium	Prewash* or Autosoak* Power Steam* Time Saver* Extra Rinse Tumble Care* or 1 Step Wash + Dry*
Whites	Whites and household linens.	Extra Heavy Heavy Normal Light Extra Light	Extra Hot Hot Warm Cold Tap Cold	Max High Medium Low	Prewash* or Autosoak* Power Steam* Time Saver* More Water* Extra Rinse Tumble Care* or 1 Step Wash + Dry*
Towels	Towels, sheets, pillowcases and dish rags.	Extra Heavy Heavy Normal Light Extra Light	Hot Warm Cold Tap Cold	Max High Medium Low	Prewash* or Autosoak* Power Steam* Time Saver* More Water* Extra Rinse Tumble Care* or 1 Step Wash + Dry*
Bulky Bedding	Large coats, bed spreads, mattress covers, sleeping bags, and similar large bulky items.	Extra Heavy Heavy Normal Light Extra Light	Hot Warm Cold Tap Cold	Max High Medium Low	Prewash* or Autosoak* Power Steam* Time Saver* More Water* Extra Rinse Tumble Care* or 1 Step Wash + Dry*
Sanitize+ Allergen*	Heavily soiled colorfast items with the need for sanitization.	Extra Heavy Heavy	Extra Hot	Max High Medium Low	Prewash Power Steam* Extra Rinse Tumble Care* or 1 Step Wash + Dry*
Sanitize With Oxi*	Heavily soiled colorfast items with the need for sanitization.	Extra Heavy Heavy	Extra Hot	Max High Medium Low	Prewash* or Autosoak* Extra Rinse Tumble Care

*Some cycles and options may not be available on some models.

Getting started

Wash Cycles - Continued

The wash cycles are optimized for specific types of wash loads. The chart below will help you match the items to be washed with the best wash cycle settings. For optimal performance, select the cycle that most closely matches the items being washed. Selections and options shown in **bold** are the suggested settings for that cycle. **Delay Wash/Remote Start** is available on all cycles.

Wash Cycle	Items to Wash	Soil Level	Wash Temp	Spin Selection	Options Available
Power Clean*	For heavily soiled items which require extra cleaning power.	Extra Heavy Heavy Normal	Extra Hot Hot Warm Cold Tap Cold	Max High Medium Low	Prewash Power Steam Extra Rinse Tumble Care* or 1 Step Wash + Dry*
Heavy Duty*	For washing heavily soiled, sturdy colorfast items using extended wash motions and rinses to deliver extra cleaning.	Extra Heavy Heavy Normal Light	Hot Warm Cold Tap Cold	Max Medium Low	Autosoak More Water* Delay Wash Extra Rinse Tumble Care
Quick Wash	Small loads of lightly soiled items that are needed in a hurry.	Normal Light Extra Light	Hot Warm Cold Tap Cold	Max High Medium Low	More Water* Extra Rinse Tumble Care* or 1 Step Wash + Dry*
Delicates	Lingerie and special care fabrics with light soil.	Normal Light Extra Light	Warm Cold Tap Cold	Medium Low No Spin	Prewash* or Autosoak* Time Saver* More Water* Extra Rinse Tumble Care* or 1 Step Wash + Dry*
Cold Wash	Cycle for normal, regular, or typical use for washing up to a full load of normally soiled cotton clothing using only cold water.	Extra Heavy Heavy Normal Light Extra Light	Cold Tap Cold	Max High Medium Low	Prewash* or Autosoak* More Water* Extra Rinse Tumble Care* or 1 Step Wash + Dry*
Active Wear*	Medium to lightly soiled athletic wear items of technical or synthetic fabrics.	Extra Heavy Heavy Normal Light Extra Light	Warm Cold Tap Cold	Medium Low No Spin	Prewash Time Saver Extra Rinse Tumble Care* or 1 Step Wash + Dry*
Rinse & Spin	For items that need only to be rinsed, use this cycle.			Max High Medium Low No Spin	More Water* Extra Rinse Tumble Care* or 1 Step Wash + Dry*
Self Clean	Cleaning the basket of residue and odor. No clothes to be washed using this cycle.			Medium	

*Some cycles and options may not be available on some models.

NOTES:

The **SANITIZE + Allergen** cycle's water temperatures CANNOT be changed. This cycle utilizes elevated water temperature and a longer wash cycle to kill dust mites and reduce 99% of common bacteria from fabrics. A pump purge and extended rinse is incorporated for the purpose of removing contaminants and allergens, such as pet dander.

The **SANITIZE With Oxi** cycle's water temperatures CANNOT be changed. This cycle, when using an Oxi additive along with your detergent, is designed to remove 99% of bacteria found in home laundry. Measure the detergent and the Oxi products carefully. Using the amounts appropriate for a large heavily soiled load in a front load washer, follow the detergent and the Oxi product label instructions. The washer hot water supply connection must provide a minimum of 120°F to ensure the effectiveness of this cycle.

Only the **SANITIZE + Allergen** and **SANITIZE With Oxi** cycles have been designed to meet the requirements of sanitizing effectiveness.

Getting started

D Settings

Individual settings for soil level (**Level**), water temperature (**Temp**) and spin speed (**Spin**) can be set from the minimum to maximum. In general, the higher up the column, the more energy will be used.

Soil

Changing the **Soil** level increases or decreases the wash time to remove different amounts of soil.

To change the **Soil** level, press the **Soil** level pad until you have reached the desired setting. You can choose between Extra Light, Light, Normal, Heavy or Extra Heavy soil levels on most cycles.

Temp

Adjust to select the proper water temperature for the wash cycle. The **AutoSoak** and **PreWash** rinse water is always cold to help reduce energy usage and reduce setting of stains and wrinkles.

Follow the fabric manufacturer's care label when selecting the wash temperature.

To change the wash temperature, press the **Temp** pad until you have reached the desired setting. You can choose between Tap Cold, Cold, Warm, Hot or Extra Hot on most cycles. By design, to protect fabrics, not all wash temperatures are available for certain wash cycles. Extra Hot temperatures are enabled by the internal heater on models equipped with Steam capabilities.

NOTE: The first 10 seconds of the wash fill is always cold. This feature assists in conditioning the fabric and preventing stains from setting on garments.

Spin

Adjusting the **Spin** speed changes the final spin speed of the cycles. Always follow the garment manufacturer's care label when changing the **Spin** speed.

To change the **Spin** speed, press the **Spin** speed pad until you have reached the desired setting. You can choose between No Spin, Low, Medium, High or Max. Higher spin speeds are not available on certain cycles, such as **DELICATES** and **ACTIVE WEAR**.

Higher spin speeds remove more water from the clothes and will help reduce dry time, but may also increase the possibility of setting wrinkles on some fabrics.

NOTE: This washer features a **dBT™ (Dynamic Balancing Technology)** system. This patented onboard sensing technology enables real-time balancing of the spin cycle for each load, saving time and providing a quiet wash. This should lead to more consistent wash times and an overall reduction in noise and vibration. If the washer should experience any excessive noise, vibration or shaking, simply **Pause** the washer, open the door, and manually redistribute the load before restarting the cycle.

E Options

SMARTDISPENSE™ (on some models)

When selected, this feature will automatically add detergent to the wash, eliminating the need to add detergent for each load. See the **SmartDispense** section for details.

MY SETTINGS (on some models)

To save your favorite settings, set the desired settings for wash cycle, soil level, spin speed and wash temp settings and hold down the **My Settings** pad for 3 seconds. A beep will sound to indicate the cycle has been saved.

To use your custom settings, press the **My Settings** pad before washing a load.

To change the saved settings, set the desired settings and hold down the **My Settings** pad for 3 seconds.

POWER STEAM (on some models)

Power Steam adds steam into the washer before the wash cycle begins to assist with loosening stains on the **NORMAL, WHITES, TOWELS, BULKY Bedding, SANITIZE+Allergen** and **POWER CLEAN** cycles.

To use:

1. Press the **Power** pad to "wake up" the washer and select a wash cycle.
2. Press the **POWER STEAM** pad to activate steam.
3. Press the **Start/Pause** pad.

WiFi (may be a shared pad with other options)

Press and hold the **WiFi*** pad for 3 seconds to activate. See the **WiFi Connect** section for details on how to get started with WiFi connection.

Getting started

E Options

Delay Wash/Remote Start

You can delay the start of a wash cycle for up to 24 hours or remote start the washer by using the **Delay Wash/Remote Start** feature. Press to step by hours or hold to scroll the **Delay Wash** pad to set the amount of time you want to delay the start of the wash cycle. If you have connected your washer to WiFi, the first selection, "APP", can be selected to enable remote starting of your washer from the GE Appliance Smartphone app. Or, if you select a delay time in hours, the machine will count down and start automatically following this period. Press the **Start** pad once you have configured the **Delay Wash** to the proper setting to enable this feature. To cancel this option, simply power off and power on the controls.

NOTE: If you forget to fully close the door, a reminder signal will beep reminding you to do so.

NOTE: If you open the door when the delay is counting down, the machine will enter the pause state. You must close the door and press **Start** again in order to restart the countdown.

Time Saver (on some models)

This option reduces the overall washer cycle time by optimizing the wash, rinse and spin actions and/or gently raising the wash temperature to get clothes cleaned faster. Option is available on **NORMAL, WHITES, TOWELS, DELICATES, BULKY Bedding** and **ACTIVE WEAR** cycles. Total wash time will vary based on cycle chosen and options selected.

To use:

1. Turn power on and select a wash cycle which has **Time Saver** as an option.
2. Press the **Time Saver** pad to reduce the overall wash time.
3. Press the **Start/Pause** pad.

More Water (on some models)

This option adds approximately 3 gallons to the wash and rinse portions of the cycle. If the option is selected before the cycle starts, the water will be added from the beginning of the wash cycle and later to the rinse. If the option is selected during the wash portion, more water will be added at this point and later to the rinse. Likewise, if the **More Water** option is selected after the wash portion has completed, the washer will add more water to the rinse only. If wash and rinse have completed, the **More Water** pad will no longer be active.

ULTRAFRESH VENT System with ODORBLOCK™ (on some models)

The ULTRAFRESH VENT System with OdorBlock was designed to eliminate excess moisture in the washer following a wash cycle to help prevent odors from developing. This washer was designed to drain water at the end of the cycle more effectively. Following the wash cycle, the user can then choose to leave the door open or select the ULTRAFRESH VENT feature to assist with drying out the gasket and other areas of the washer. The OdorBlock system features multiple components which are manufactured with Microban® antimicrobial technology.* Microban is a safe and effective antimicrobial technology that will last the life of your washer. For more information, please visit www.microban.com/geappliances.

ULTRAFRESH VENT is available after the wash cycle is complete and you have removed your cleaned laundry. Once the door is closed, a notification tune will play and the **ULTRAFRESH VENT** pad LED will blink. Upon pressing the pad, ULTRAFRESH VENT will begin.

To select ULTRAFRESH VENT at any other point, power on the washer, ensure a cycle is not actively running, and remove any garments from the basket, then press and release the **ULTRAFRESH VENT** pad so that the notification tune plays and the **ULTRAFRESH VENT** pad LED begins to blink. Then press the **ULTRAFRESH VENT** pad again to start the feature.



During the operation of ULTRAFRESH VENT the door will remain locked and the washer will intermittently spin at low speeds for up to 8 hours.

If garments are detected in the basket during ULTRAFRESH VENT, the washer will instead run **TUMBLE CARE** or **1 STEP WASH + DRY**, based on option availability for your model.

The ULTRAFRESH VENT feature may be cancelled at any time by pressing the **POWER** pad, turning the cycle knob, or pressing the **ULTRAFRESH VENT** pad.

*Microban® is a registered trademark of Microban International, Ltd.

Getting started

E Options

1 STEP WASH + DRY (on some models)

This option is available on all cycles except **Self Clean**.

The **1 STEP WASH + DRY** is intended for small loads only. Use when clothes need to be washed, dried and ready to wear or finished the next morning. This feature will tumble clothes and introduce a constant stream of air into the washer compartment upon completion of select wash cycles. Although the drying portion is set to 8 hours, the clothes can be removed at any time by pressing **Pause** or **Power** to cancel the cycle.

Tumble Care (on some models)

Freshly tumbles your garments periodically for up to 8 hours after the wash cycle is complete to lessen the setting of wrinkles and creases when you are not able to move clothing to the dryer right away.

At the end of the cycle, the display will scroll "END" and after ten minutes the **Tumble Care** will begin. It can be stopped at any time by pressing the **Power** pad.

PreWash (on some models)

Prewash is an extra wash before the main wash. Use it for heavily soiled clothes or for clothes with a care label that recommends prewashing before washing. Be sure to add liquid or powder high-efficiency detergent, or the proper wash additive to the prewash dispenser. Washers equipped with **SmartDispense** will automatically add the proper amount of detergent for prewash based on the load size.

PreWash must be selected prior to pressing **Start**.

The **PreWash** feature will fill the washer (adding the prewash detergent), tumble the clothes, drain and spin. Then the washer will run the selected wash cycle.

NOTE: In some special cycles, the prewash is selected automatically as the default. You can turn off this selection at any time.

AutoSoak (on some models)

For soaking your garments prior to the wash cycle. This option begins with a brief tumble and then proceeds to soak the clothes with water and detergent for a specified period of time. Once complete, the cycle will continue automatically. **AutoSoak** must be selected prior to pressing the start pad. The **AutoSoak** time will add an additional 15 minutes, 30 minutes, 1 hour or 2 hours to the overall wash time. High-efficiency detergent from the main wash compartment in the dispenser is used for the **AutoSoak** period and main wash cycle.

Extra Rinse

This option allows for an extra rinse during a cycle to remove excess dirt and detergent from soiled loads.

Press the **Extra Rinse** pad to select.

NOTE: On **RINSE & SPIN** cycle, a **drain and spin** cycle can be achieved by pressing the **Extra Rinse** pad until the LED is no longer illuminated.

Light (on some models)

The basket light will turn on and remain on for 5 minutes when the door opens, **Start/Pause** pad is pressed, or by pressing the **Light** pad.

The basket light can be turned off by pressing the **Light** pad.

Add Garment (on some models)

If you need to add a garment after the cycle has started, press the **Add Garment** pad and the unit will unlock the door, allowing additional garments. The **Add Garment** feature is only available when the LED is lit on the pad. After a certain point in the cycle, the LED will not be lit any longer and adding a garment is not allowed.

Sound

To change the loudness of the end of cycle signal and the press pad volume, press the **Sound** pad as many times as needed to reach the desired volume. There are four sound levels including off.

Control Lock (Light-Control Lock pad) (depending on model)

You can lock the controls to prevent any selections from being made. Or you can lock or unlock the controls after you have started a cycle.

Children cannot accidentally start the washer by touching pads with this option selected.

To lock/unlock the washer, press and hold the **Control Lock/Light-Control Lock** pad for 3 seconds. A sound is made to indicate the lock/unlock status. The control lock icon on the display will light up when it is on.

NOTE: The **Power** pad can still be used when the machine is locked.

Getting started

Dispenser Drawer

Slowly open the dispenser drawer by pulling it out until it stops. After adding laundry products, slowly close the dispenser drawer. Closing the drawer too quickly could result in early dispensing of the bleach, fabric softener or detergent.

You may see water in the detergent, bleach and fabric softener compartments at the end of the cycle. This is a result of the flushing/siphoning action and is part of the normal operation of the washer.

Do **NOT** put detergent packets in the dispenser drawer.

NOTE: Use only liquid or powder HE detergents and additives in the dispenser drawer. Laundry detergent packets should only be added directly to the wash basket following the manufacturer's directions.

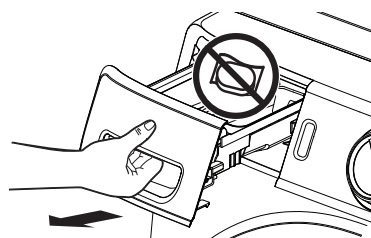

Use only HE High-Efficiency detergent



SmartDispense™ (on some models)

When selected, this feature will automatically add detergent to the wash, eliminating the need to add detergent for each load.

The detergent amount selection on the control panel will default to **AUTO** when first powering up the washing machine. When **AUTO** is selected, the amount of detergent needed for each laundry load will automatically be determined based on the size of the load the machine senses.

For **AUTO**, the washer will dispense approximately 1.5 oz of detergent for an 8 lb normal load. For other loads, it will adjust proportionally based on the size of load and garment type. If you select **LESS**, the amount of detergent will be reduced by 40%. This may be desired for higher concentrate detergents or if you have very soft water. For heavily soiled loads, you may want to select **MORE** to add 40% more detergent than the **AUTO** level.

NOTE: Not all cycles will allow the use of the SmartDispense feature. If the light is not illuminated and pressing the **SMART DISPENSE** pad results in a beeping tone, then SmartDispense is not allowed for the cycle that has been selected. Detergent will need to be added directly to the detergent compartment for these cycles.

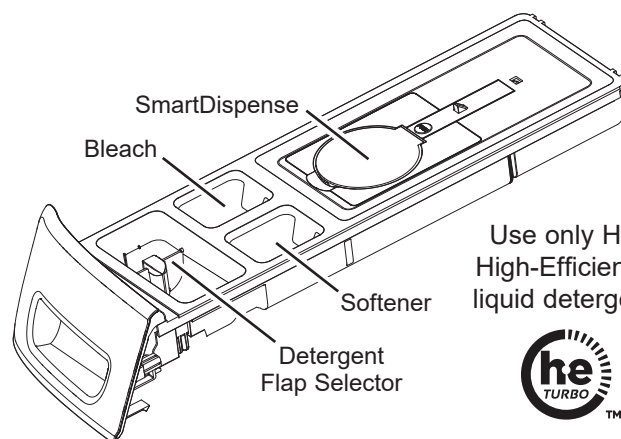

Use only HE High-Efficiency liquid detergent



If it is desired to manually add detergent for a particular load:

1. Press the **SMART DISPENSE** pad on the control panel until its light turns off which indicates the SmartDispense feature has been turned off.
2. Set the flap in the detergent compartment to the type of detergent to be used - Powder or Liquid. See the **Detergent Compartment** section.
3. Add the desired amount of detergent into the detergent compartment.

Prewash Compartment (on some models)

Only use the prewash compartment if you are selecting the **PreWash** cycle for heavily soiled clothes. Add measured detergent or prewash additive to the back left prewash compartment of the dispenser drawer.

- Detergent or prewash additive is flushed from the dispenser in the **PreWash** (if selected).
- Detergent usage may need to be adjusted for water temperature, water hardness, size and soil level of the load. Avoid using too much detergent in your washer as it can lead to over sudsing and detergent residue being left on the clothes.

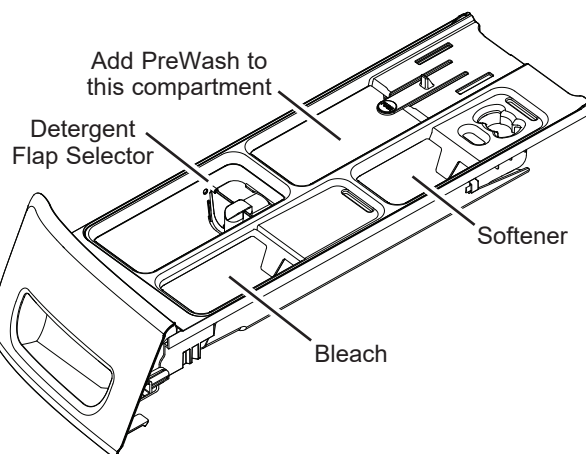

Getting started

On models with SmartDispense:

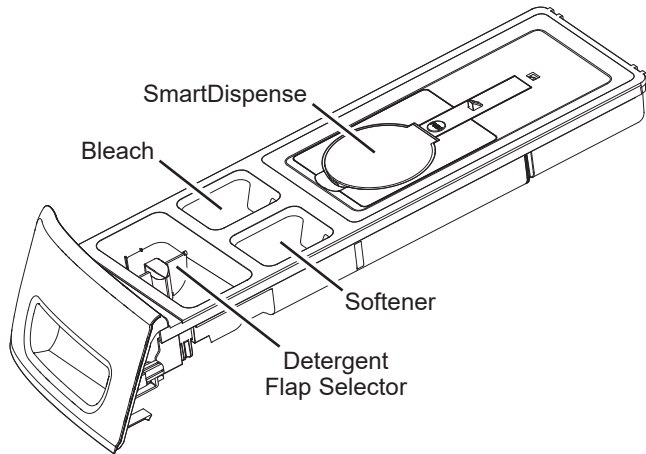

On models without SmartDispense:

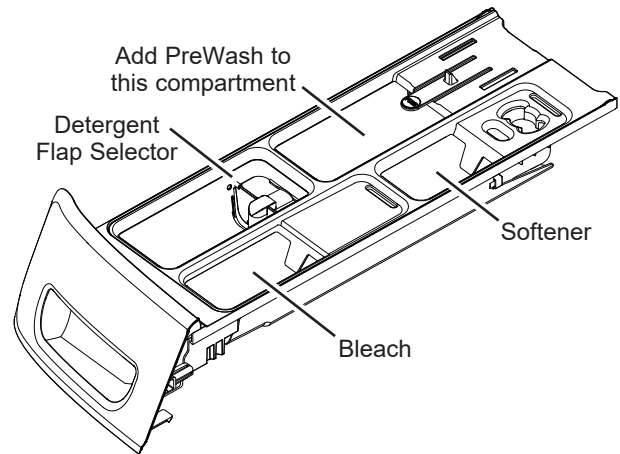

Detergent Compartment

Only use high-efficiency detergent in this washer. Do NOT fill high-efficiency detergent over the MAX line. Use detergent manufacturer's recommended amount.

- **Powder Detergent** – Lift the flap up for powder detergent. This must be done to dissolve and flush detergent properly. Follow the detergent manufacturer's instructions when measuring the amount of powder detergent to use.
- **Liquid Detergent** – Keep the flap down for liquid detergent. This retains the liquid detergent until it automatically flushes at the start of the wash cycle. Follow the detergent manufacturer's instructions when measuring the amount of liquid detergent to use.

Detergent usage may need to be adjusted for water temperature, water hardness, size and soil level of the load. Avoid using too much detergent in your washer as it can lead to oversudsing, detergent residue being left on the clothes, and could extend wash times.

Do not put clumped detergent in the dispenser. Clumped detergent can cause a leak.

Do **NOT** put detergent packets in the dispenser drawer.

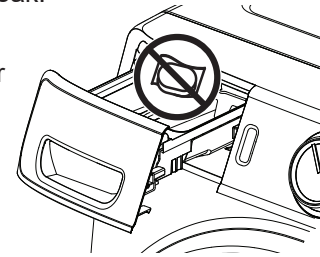

Liquid Bleach Compartment

If desired, measure out the recommended amount of liquid bleach, not to exceed 1/3 cup (80 ml) and pour into the compartment labeled "LIQUID BLEACH" marked with this symbol .

It is recommended to use High-Efficiency (HE) bleach in this front-load washer.

Do not exceed the maximum fill line. Overfilling can cause early dispensing of the bleach which could result in damaged clothes.

NOTE: Do not use powdered bleach or laundry detergent/additive packets in the dispenser.

Fabric Softener Compartment

If desired, pour the recommended amount of liquid fabric softener into the compartment labeled "FABRIC SOFTENER".

Use only liquid fabric softener in the dispenser.

Dilute with water to the maximum fill line.

Do not exceed the maximum fill line. Overfilling can cause early dispensing of the fabric softener, which could stain clothes.

NOTE: Do not pour fabric softener directly on the wash load.

Consumer Help Indicator

Your washer is equipped with Consumer Help Indicator (CHI). CHI is our way to communicate a simple remedy for some situations that you can perform without the need to call for service. The chart below describes the helpful messages you may notice scrolling on your display when you return to start another load. These messages will provide simple remedies you can quickly perform.

<p>Spin light blinking</p>	<p>If an out-of-balance condition is detected by the washer, the Spin light will blink during the remaining portion of the cycle and will stay illuminated for a short time after cycle completion. When this occurs, the washer is taking actions to correct the out-of-balance condition and complete the cycle normally. In some cases, the washer may not be able to balance the load and spin up to full speed. If you notice the load is more wet than normal at the end of the cycle, redistribute the load evenly in the wash basket and run a Drain & Spin cycle. (See Extra Rinse in the Getting Started - Options section for details.)</p>
<p>"H2O SUPPLY" (Water not entering washer)</p>	<p>Check your house water supply. Did you forget to turn on one or both supply valves after installation or coming back from vacation? As soon as the message starts to scroll, the washer will initiate a 4 minute lock-out period. The washer controls won't respond/change during this time. After the 4 minutes, you can begin your cycle again. If you try to bypass the lock-out period by unplugging the washer, the 4 minute timer will start over again.</p>
<p>"CAnCELEd"</p>	<p>"CAnCELEd" may scroll on the display if the machine was paused for longer than 24 hours or if the machine has stopped itself before the cycle completed due to certain errors. As soon as the message starts to scroll, the washer will initiate a 4 minute lock-out period. The washer controls won't respond/change during this time. After the 4 minute period, you can begin your cycle again. If you try to bypass the lock-out period by unplugging the washer, the 4 minute timer will start over again. If the problem persists, call GE Appliances at 800.GE.CARES (800.432.2737) for service.</p>
<p>"door"</p>	<p>"door" will be shown on the display if you try to start a cycle when the door is not fully closed. "door" will also be shown on display if 3 cycles have been started without opening the door. The washer will not start another cycle until the door is opened. In either circumstance, try opening and closing the door, and then starting a new cycle. If the problem persists, call GE Appliances at 800.GE.CARES (800.432.2737) for service.</p>

Appliance Communication

WiFi Connect (For customers in the United States only - on some models)

Your washer is **GE Appliances WiFi Connect** enabled.

Visit geappliances.com/connect and enter your model number to show you the proper steps to connect your appliance.

Please visit GEAppliances.com/connect to learn more about connected appliance features, to learn what connected appliance app's will work with your smartphone.

WiFi Connectivity: For assistance with the appliance or the **ConnectPlus** network connectivity, please call GE Appliances at **800.220.6899**.

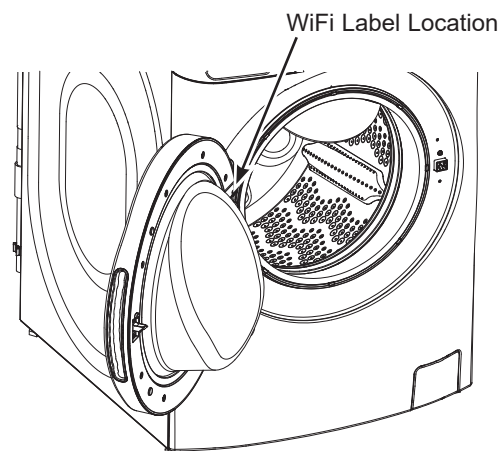

Loading

Always follow fabric manufacturer's care label when laundering.

Sorting Wash Loads

Sort by color (whites, lights, colors), soil level, fabric type (sturdy cottons, easy care, delicates) and whether the fabric produces lint (terry cloth, chenille) or collects lint (velveteen, corduroy). Wash lint producers such as cotton towels and socks separate from lint collectors including synthetic garments and dress pants.

⚠ WARNING  - Fire Hazard

DO NOT wash fabrics soiled with flammable liquids or cleaning solvents.

No washer can completely remove oil.

DO NOT wash or dry anything that has been soaked in or spotted with any type of oil (including cooking oils).

DO NOT reach into the washer until all moving parts have stopped.

Doing so can result in death, explosion, fire or amputation.

Loading the Washer

The wash drum may be fully loaded with loosely added items.

To add items after the washer has started, press **Start/Pause** and wait until the door is unlatched. The washer may take up to 30 seconds to unlock the door after pressing **Start/Pause**, depending on the machine conditions. Do not try to force open the door when it is locked. After the door unlocks, open gently. Add items, close the door and press **Start/Pause** to restart.

Loading Examples

WORKWEAR	LINENS	MIXED LOAD	DELICATES*	QUICK WASH (2-3 GARMENTS)
4 Jeans 5 Work Wear Shirts 3 Work Wear Pants	2 Bath Sheets 10 Bath Towels/ 12 Washcloths 7 Hand Towels/ 2 Terrycloth Bath Mats OR 2 Flat Queen-Sized Sheets 2 Fitted Queen-Sized Sheets 4 Pillowcases	4 Pillowcases 2 Hand Towels 2 Flat Sheets/ 2 Fitted Sheets 2 Bath Towels/ 4 Washcloths OR 6 Shirts (Men's or Women's) 4 Pair Pants (Khakis or Twills) 5 T-shirts 7 Pairs of Boxers 4 Pairs of Shorts OR 6 T-shirts 4 Pairs of Sweatpants 4 Sweatshirts 2 Hoodies 7 Pairs of Socks	7 Bras 7 panties 3 Slips 2 Camisole 4 Nightgowns *Using a nylon mesh bag for small items is recommended.	2 Casual Wear Work Shirts 1 Pair Casual Wear Work Pants OR 3 Soccer Uniforms

Care and cleaning

Water Supply Hoses

Hoses connecting washer to faucet should be replaced every 5 years.

Exterior

Immediately wipe off any spills. Wipe or dust spills or washing compounds with a damp cloth. Washer control panel and finishes may be damaged by some laundry pretreatment and stain remover products. Apply these products away from the washer. The fabric may then be washed and dried normally. Damage to your washer caused by these products is not covered by your warranty. Do not hit surface with sharp objects.

Interior

Dry around the washer door opening, flexible gasket (including attached hoses) and door glass. These areas should always be clean to ensure a watertight seal. You will notice if you regularly use the ULTRAFRESH VENT System that this will not be required as often. It is recommended to rinse the washer at least once per month with 1 cup of bleach (or other commercially available product manufactured for this purpose, such as Tide® Washing Machine Cleaner) poured directly into the basket without clothes and using the **Self Clean** Cycle.

Self Clean

To clean the interior of the washer, select the **SELF CLEAN** feature on the control panel. This **Self Clean** cycle should be performed, at a minimum, once per month or about every 30-40 wash cycles. This cycle will use more water, in addition to bleach, to control the rate at which soils and detergents may accumulate in your washer.

NOTE: Read the instructions below completely before starting **Self Clean** cycle.

1. Remove any garments or objects from the washer and ensure the washer basket is empty.
2. Open the washer door and pour one cup or 250 ml of liquid bleach or other washing machine cleaner into the basket.
3. Close the door and select the **SELF CLEAN** cycle. Push the **Start** pad.
4. When the **Self Clean** cycle is working, the display will show the estimated cycle time remaining. The cycle will complete in about 90 minutes. Do not interrupt the cycle.



5. After the cycle is complete (on some models), the washer will automatically start an ULTRAFRESH VENT operation so that the door can remain closed until the next time you use the washer.

If for any reason the cycle needs to be interrupted, the door will not open immediately. Forcing open the door at this stage may cause water to flood. The door will open after the water is drained to a level where it would not flood the floor.

Self Clean may be interrupted by pressing the **Start** pad in between cycles. A power outage in the house might also interrupt the cycle. When the power supply is back, the **Self Clean** cycle resumes where it had stopped. When interrupted, be sure to run a complete **Self Clean** cycle before using the washer. If the **Power** pad is pressed during **Self Clean**, the cycle will be lost.

IMPORTANT:

- Run **Self Clean** with one Cup (250 ml) of bleach once a month.
- After the completion of a **Self Clean** cycle, the interior of your washer may have a bleach smell.
- It is recommended to run a **RINSE & SPIN** or a light color load after the **Self Clean** cycle.

Door Gasket

Open the washer door. Using both hands, press down the door gasket.

While holding down the door gasket, inspect the interior fold. Remove any foreign objects if found trapped inside this gasket.

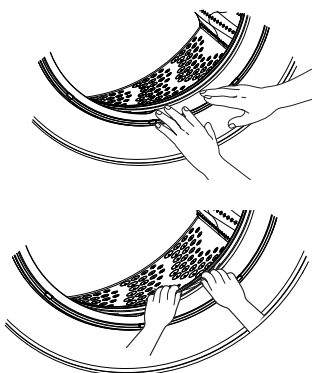

Make sure there is nothing blocking the holes behind the gasket.

When you are finished cleaning the door gasket, release it and the gasket will return to the operating position.



Care and cleaning

Dispenser Drawer Area

Detergent and fabric softener may build up in the dispenser drawer. Residue should be removed once or twice a month.

- Remove the drawer by first pulling it out until it stops. Then reach back into the rear of the drawer cavity and press down firmly on the lock tab, pulling out the drawer.
- Rinse the drawer with hot water to remove traces of accumulated laundry products.
- To clean the drawer opening, use a small brush to clean the recess. Remove all residue from the upper and lower parts of the recess.
- Replace the dispenser drawer.
- To reduce buildup in the Dispenser Drawer area:

Use only HE
High-Efficiency
detergent



On models with
SmartDispense:

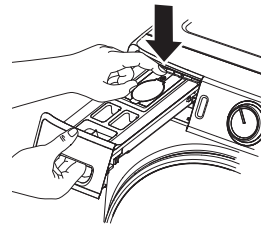

On models without
SmartDispense:

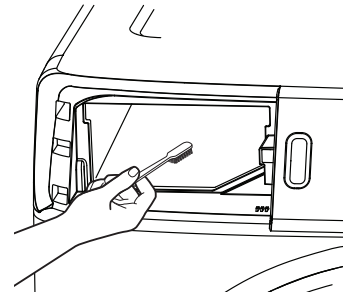
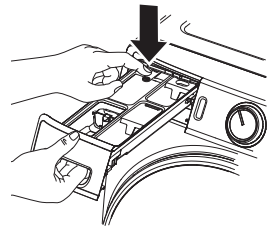

Pump Filter

Due to the nature of the front-load washer, it is sometimes possible for small articles to pass to the pump. The washer has a filter to capture lost items so they are not dumped to the drain. To retrieve lost items, clean out the pump filter.

1. Using a small flathead screwdriver or coin, open the access door.
2. Place a shallow pan or dish under the pump access door and towels on the floor in front of the washer to protect the floor. It is normal to catch about a cup of water when the filter is removed.
3. Pull down the pour spout.
4. Turn the pump filter counterclockwise and remove the filter slowly, controlling the flow of the draining water.
5. Remove the filter and clean the debris from the filter.
6. Replace the filter and turn clockwise. Tighten securely.
7. Flip up the pour spout.
8. Close the access door by hooking the bottom tabs first, then rotating the access door shut.

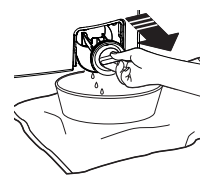
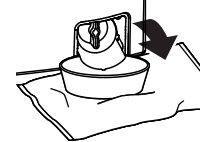
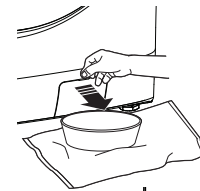

Video

Scan this code to watch a video on this topic.

Moving and Storage

Ask the service technician to remove water from drain pump and hoses. Do not store the washer where it will be exposed to the weather. When moving the washer, the tub should be kept stationary by using the shipping bolts removed during installation. See Installation Instructions in this manual. If these parts are not available, they can be ordered by visiting our Website at GEApplianceparts.com or by calling GE Appliances at 877.959.8688. In Canada, visit your local GE Appliances parts distributor or call 800.661.1616 or GEAppliances.ca/en/products/parts-filters-accessories.

Long Vacations

Be sure water supply is shut off at faucets. Drain all water from hoses and water filter pump area if weather will be below freezing.

Installation Instructions

Washer

If you have any questions, call GE Appliances at 800.GE.CARES (800.432.2737) or visit our Website at: GEAppliances.com
In Canada, call 800.561.3344 or visit GEAppliances.ca

BEFORE YOU BEGIN

Read these instructions completely and carefully.

- **IMPORTANT** — Save these instructions for local inspector's use.
- **IMPORTANT** — Observe all governing codes and ordinances.
- **Note to Installer** — Be sure to leave these instructions with the Consumer.
- **Note to Consumer** — Keep these instructions for future reference.
- **Skill level** — Installation of this appliance requires basic mechanical and electrical skills.
- **Completion time** — 1-3 hours
- Proper installation is the responsibility of the installer.
- Product failure due to improper installation is not covered under the Warranty.

LOCATION OF YOUR WASHER

DO NOT Install the Washer:

1. In an area exposed to dripping water or outside weather conditions. The ambient temperature should never be below 60°F (15.6°C) for proper washer operation.
2. In an area where it will come in contact with curtains or drapes.
3. On carpet. The floor **MUST** be a hard surface with a maximum slope of 1/2" per foot (1.27 cm per 30 cm). To make sure the washer does not vibrate or move, you may have to reinforce the floor.

NOTE: If floor is in poor condition, use 3/4" impregnated plywood sheet solidly attached to existing floor covering.

MOBILE HOME INSTALLATION:

Installation must conform to Standard for Mobile Homes, ANSI A119.1 and National Mobile Home Construction and Safety Standards Act of 1974 (PL93-383).

TOOLS REQUIRED

- Level
- Adjustable wrench



- Channel-lock adjustable pliers



- Phillips screwdriver



PARTS SUPPLIED

- Shipping Bolt Covers
- Drain Hose Guide

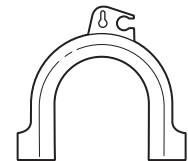

- Lock Bar (Retain for Reversing the Door Swing option)



- Cable Tie



PARTS REQUIRED (Sold separately or included with the GFW510 model)

- Water Hoses (2)
- Rubber Washers (2) and Strainer Screens (2)



GE Appliances Parts and Accessories

Order on-line at GEApplianceparts.com today, 24 hours a day or by phone at 877.959.8688 during normal business hours. In Canada, visit your local GE Appliances parts distributor or call 800.661.1616 or GEAppliances.ca/en/products/parts-filters-accessories.

Part Number Accessory

WX14X10011 6 ft stainless steel washer hoses with 90° elbows; 2-pack

WH1X2267 Rubber Washer (1) and Screen (1)

Installation Instructions

WASHER DIMENSIONS

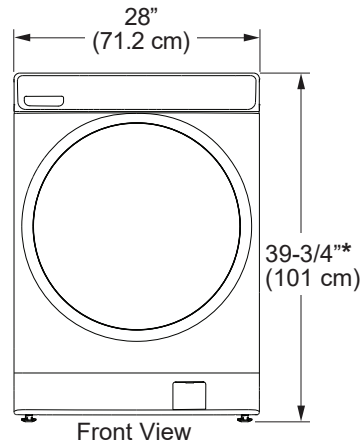

Model - GFW850:

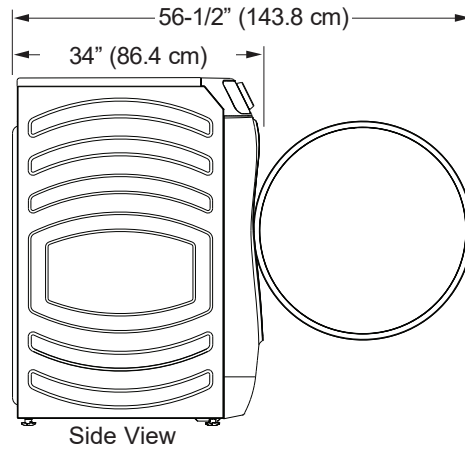

Models - GFW650, GFW550, GFW510, HFW350:

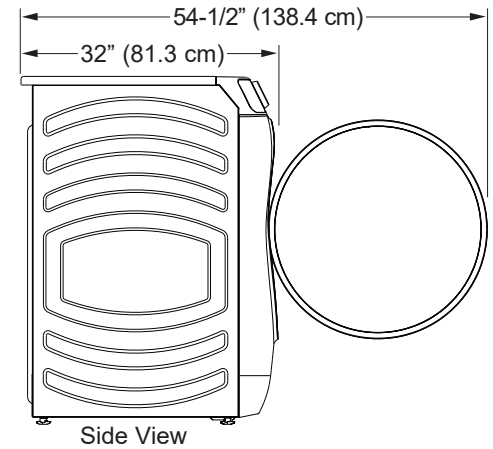

*With leveling legs retracted: 39-3/4 (101 cm). / With leveling legs fully extended: 40-5/8 (103.1 cm).

MINIMUM CLEARANCES

Alcove or Closet

- Rear = 0"*
- Sides = 0"
- Top = 0"
- Front = 0"

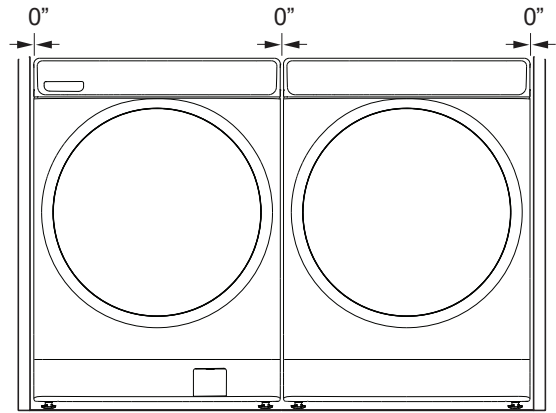
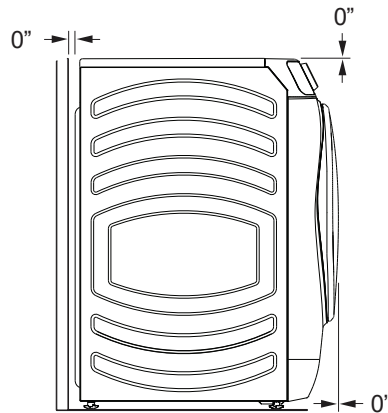

- Consideration must be given to provide adequate clearance for installation and service.
 - Closet doors must be louvered or otherwise ventilated and have at least 60 square inches (387.1 cm²) of open area. If the closet contains both a washer and a dryer, doors must contain a minimum of 120 square inches (774.2 cm²) of open area.
- *To enable 0" clearance on the back of the washer, you must use 90° elbow hoses. Otherwise you may require some additional clearance to avoid rubbing of the hoses against the back wall.

ACCESSORIES:

Order on-line at GEApplianceparts.com, 24 hours a day or by phone at **877.959.8688** during normal business hours.

Part Number	Accessory
GFR0728SNWW	White Riser
GFR0728PNSN	Satin Nickel Riser
GFR0728PNRS	Royal Sapphire Riser
GFR0728PNDG	Diamond Gray Riser
GFP1528SNWW	White Pedestal
GFP1528PNSN	Satin Nickel Pedestal
GFP1528PNRS	Royal Sapphire Pedestal
GFP1528PNDG	Diamond Gray Pedestal
GFA28KITN	Stacking Kit for Dryer over Washer

Riser:

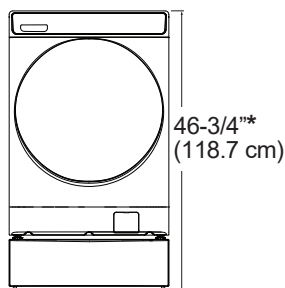

Pedestal:

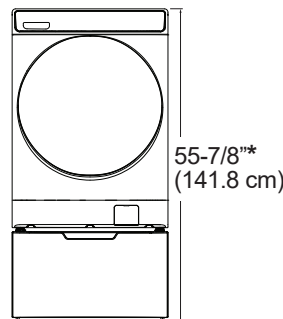

Stacked:

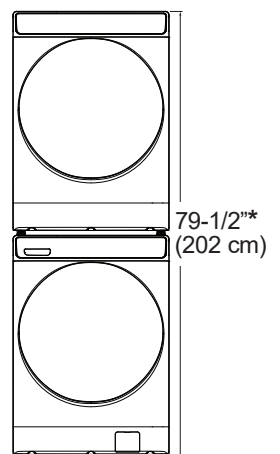

Follow the **Installation Instructions** included in the Kit for all clearances and installation requirements.

*With leveling legs retracted. See the **WASHER DIMENSIONS** section above for legs extension dimensions.

Installation Instructions

UNPACKING THE WASHER

▲ WARNING Recycle or destroy the carton and plastic bags after the washer is unpacked. Make materials inaccessible to children. Children might use them for play. Cartons covered with rugs, bedspreads or plastic sheets can become airtight chambers causing suffocation.

1. Cut and remove all packaging straps.
2. While it is in the carton, carefully lay the washer on its side. DO NOT lay the washer on its front or back.
3. Turn down the bottom flaps. Remove all base packaging including the styrofoam base.
4. Carefully return the washer to an upright position and remove the carton by lifting it upward.
5. Carefully move the washer to within 4 feet (122 cm) of the final location.
6. Remove the following from the back side of the washer:
 - 4 bolts
 - 4 plastic spacers (including power cord retainers and rubber grommets)
 - 1 bracket

NOTE: Do NOT remove the screw or clip holding the hose.

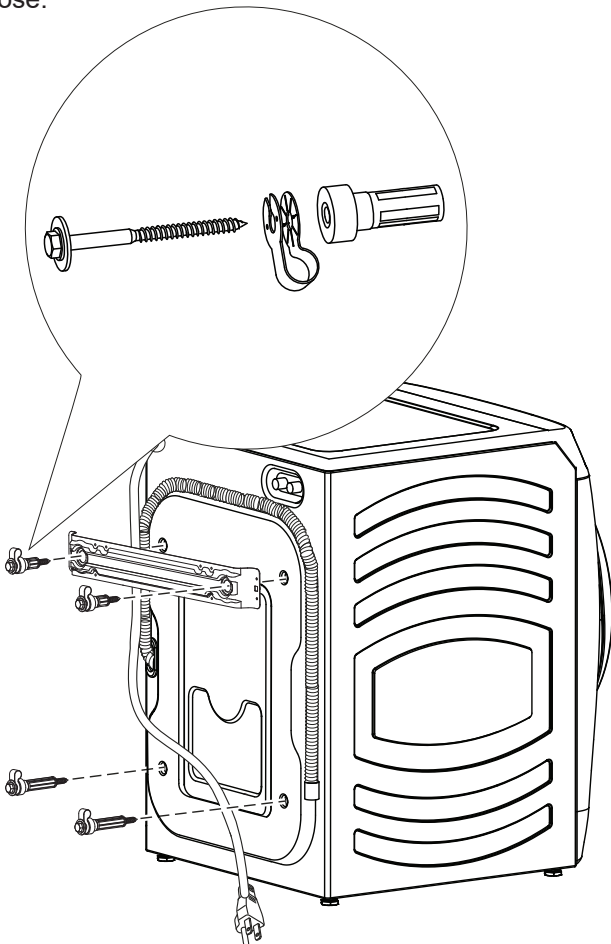

UNPACKING THE WASHER (cont.)

7. Insert shipping bolt hole covers into shipping bolt holes.

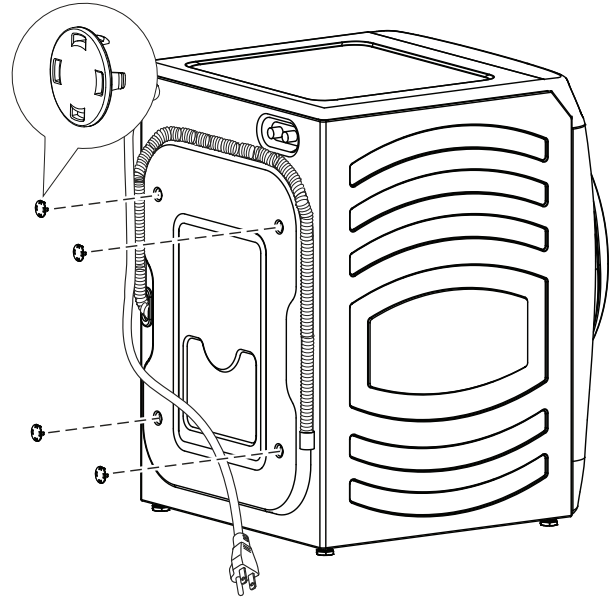

IMPORTANT:

- Failure to remove all shipping support hardware can cause the washer to become severely unbalanced.
- Save all shipping support hardware for future use. If you must transport the washer at a later date, you must reinstall all shipping support hardware to prevent shipping damage.

Installation Instructions

ELECTRICAL REQUIREMENTS

⚠ WARNING - Electrical Shock Hazard

Plug into a grounded 3-prong outlet.

DO NOT remove ground prong.

DO NOT use an adapter.

DO NOT use an extension cord.

Failure to follow these instructions can result in death, fire or electrical shock.

CIRCUIT – Individual, properly polarized and grounded 15 or 20 amp circuit breaker or time-delay fuse.

POWER SUPPLY – 2 wire plus ground, 120 Volt, single phase, 60 Hz, alternating current.

Outlet Receptacle – Properly grounded 3-prong receptacle to be located so the power cord is accessible when the washer is in an installed position. If a 2-prong receptacle is present, it is the owner's responsibility to have a licensed electrician replace it with a properly grounded 3-prong grounding type receptacle.

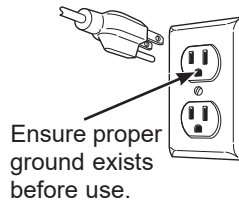

Washer must be electrically grounded in accordance with local codes and ordinances, or in the absence of local codes, with latest edition of the NATIONAL ELECTRICAL CODE, ANSI/NFPA NO. 70 or CANADIAN ELECTRICAL CODE, CSA C22.1. Check with a licensed electrician if you are not sure that the washer is properly grounded.

GROUNDING INSTRUCTIONS

This appliance must be grounded. In the event of malfunction or breakdown, grounding will reduce the risk of electric shock by providing a path of least resistance for electric current. This appliance is equipped with a cord having an equipment-grounding conductor and a grounding plug. The plug must be plugged into an appropriate outlet that is properly installed and grounded in accordance with all local codes and ordinances.

⚠ WARNING Improper connection of the equipment-grounding conductor can result in a risk of electrical shock. Check with a qualified electrician, or service representative or personnel, if you are in doubt as to whether the appliance is properly grounded. **DO NOT** modify the plug on the power supply cord. If it will not fit the outlet, have a proper outlet installed by a qualified electrician.

If required by local codes, an external 18 gauge or larger copper ground wire (not provided) may be added. Attach to washer cabinet with a #10-16 x 1/2" sheet metal screw (available at any hardware store) to rear of washer.

⚠ WARNING - Electrical Shock Hazard

Disconnect power supply before servicing.

Replace all parts and panels before operating.

Failure to do so can result in death or electrical shock.

⚠ WARNING - Shock Hazard

Certain internal parts are intentionally not grounded and may present a risk of electric shock only during servicing.

Service personnel – DO NOT contact the following parts while the appliance is energized: water valve, drain pump, NTC, heater, door lock, inverter board, motor and MC board.

WATER SUPPLY REQUIREMENTS

The faucets **MUST** be 3/4" (1.9 cm) garden hose-type so inlet hoses can be connected. Water pressure **MUST** be between 10 and 120 pounds per square inch. Your water department can advise you of your water pressure. The hot water temperature should be set to deliver water at 120° to 140°F (48°–60°C) to provide proper Automatic Temperature Control (ATC) performance.

DRAIN REQUIREMENTS

1. Drain capable of eliminating 10 gallons (38 L) per minute.
2. A standpipe diameter of 1-1/4" (3.18 cm) minimum.
3. The standpipe height above the floor should be:
Minimum height: 24" (61 cm)
Maximum height: 96" (244 cm)

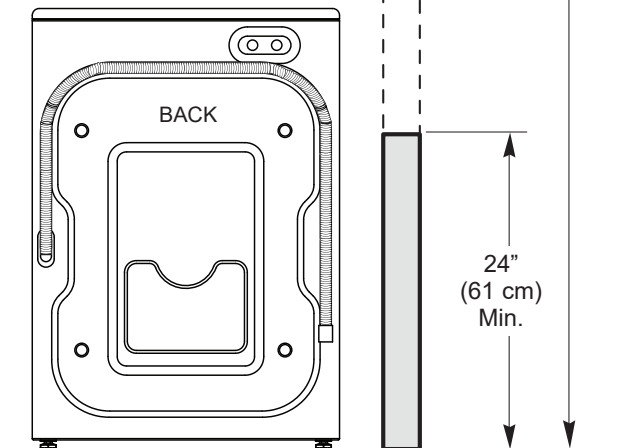

Installation Instructions

INSTALLING THE WASHER

1. Run some water from the hot and cold faucets to flush the water lines and remove particles that might clog the inlet hose and water valve screens.
2. Remove the inlet hoses from the packaging (whether supplied with the washer or sold separately).

3. (90° elbow end) Ensure there is a rubber washer in the 90° elbow end of the HOT and COLD hoses. Reinstall the rubber washer into the hose fitting if it has fallen out during shipment. Carefully connect the inlet hose marked HOT to the outside "H" outlet of the water valve. Tighten by hand, then tighten another 2/3 turn with pliers. Carefully connect the other inlet hose to the inside "C" outlet of the water valve. Tighten by hand; then tighten another 2/3 turn with pliers. **Do not crossthread or over-tighten these connections.**

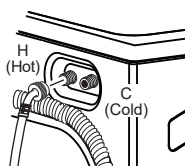

4. If inlet hose screen washers are not already inserted into the inlet hoses, install them by inserting into the free ends of the HOT and COLD inlet hoses with protruded side facing the faucet.
5. Connect the inlet hose ends to the HOT and COLD water faucets tightly by hand, then tighten another 2/3 turn with pliers. Turn the water on and check for leaks.

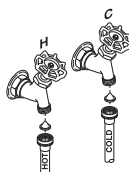

6. Carefully move the washer to its final location. Gently rock the washer into position. It is important not to damage the rubber leveling legs when moving your washer to its final location. Damaged legs can increase washer vibration. It may be helpful to spray window cleaner on the floor to help move your washer into its final position.

NOTE: To reduce vibration, ensure that all four rubber leveling legs are firmly touching the floor. Push and pull on the back right and then back left of your washer.

NOTE: Do not use the dispenser drawer or door to lift the washer.

NOTE: If you are installing into a drain pan, you can use a 24-inch long 2x4 to lever the washer into place.

7. With the washer in its final position, place a level on top of the washer (if the washer is installed under a counter, the washer should not be able to rock). Adjust the front leveling legs up or down to ensure the washer is resting solidly. Turn the lock nuts on each leg up toward the base of the washer and snug with a wrench.

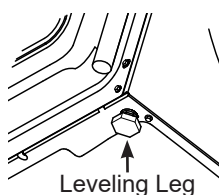

NOTE: Keep the leg extension at a minimum to prevent excessive vibration. The farther out the legs are extended, the more the washer will vibrate.

If the floor is not level or is damaged, you may have to extend the rear leveling legs.



INSTALLING THE WASHER (cont.)

8. Attach U-shaped hose guide to the end of the drain hose. Place the hose in a laundry tub or standpipe and secure it with the cable tie provided in the enclosure package.

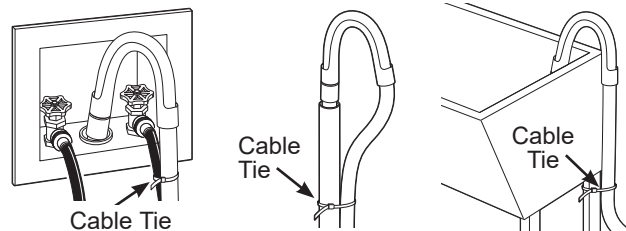

NOTE: Placing the drain hose too far down the drain pipe can cause a siphoning action. No more than 7 inches of hose should be in the drain pipe. There must be an air gap around the drain hose. A snug fit can cause a siphoning action.

9. Plug the power cord into a grounded outlet.
10. Turn on the power at the circuit breaker/fuse box.
11. Read the rest of this Owner's Manual. It contains valuable and helpful information that will save you time and money.

12. Before starting the washer, check to make sure:

- Main power is turned on.
- The washer is plugged in.
- The water faucets are turned on.
- The unit is level and all four leveling legs are firmly on the floor.
- The shipping support hardware is removed and saved.
- The drain hose is properly tied up.
- There are no leaks at the faucet, drain line or washer.

13. Run the washer through a complete cycle. Check for water leaks and proper operation.
14. If your washer does not operate, please review the Before You Call For Service section before calling for service.
15. Place these instructions in a location near the washer for future reference.

REPLACEMENT PARTS

If replacement parts are needed for your washer, they can be ordered in the United States by visiting our Website at GEApplianceparts.com or by calling GE Appliances at 877.959.8688. In Canada, visit GEAppliances.ca/en/products/parts-filters-accessories or call 800.661.1616.

Installation Instructions

REVERSING THE DOOR SWING (Optional)

⚠ WARNING

Unplug the appliance or turn off the circuit breaker before servicing. Pressing the **Power** pad **DOES NOT** disconnect power.

⚠ WARNING - Shock Hazard

Certain internal parts are intentionally not grounded and may present a risk of electric shock only during servicing.

Service personnel – DO NOT contact the following parts while the appliance is energized: water valve, drain pump, NTC, heater, door lock, inverter board, motor and MC board.

IMPORTANT NOTES

- Handle parts carefully to avoid scratching paint.
- Provide a non-scratching work surface for the door.
- Set screws down by their related parts to avoid using them in the wrong places.
- Once you begin, do not move the cabinet until door-swing reversal is completed.
- These instructions are for changing the hinges from the left side to the right side—if you ever want to switch them back to the right side, follow these same instructions and reverse all references to the left and right.

TOOL YOU WILL NEED

- Phillips-head screwdriver

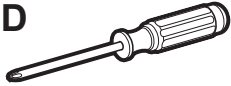

PART SUPPLIED

- Lock Bar

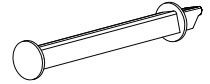

1 REMOVE THE DOOR ASSEMBLY

- Open the washer door.
- While supporting the door, remove the 4 screws from the hinge in the washer face.
- Lift the door assembly to remove it from the washer face and set it on a protective surface.

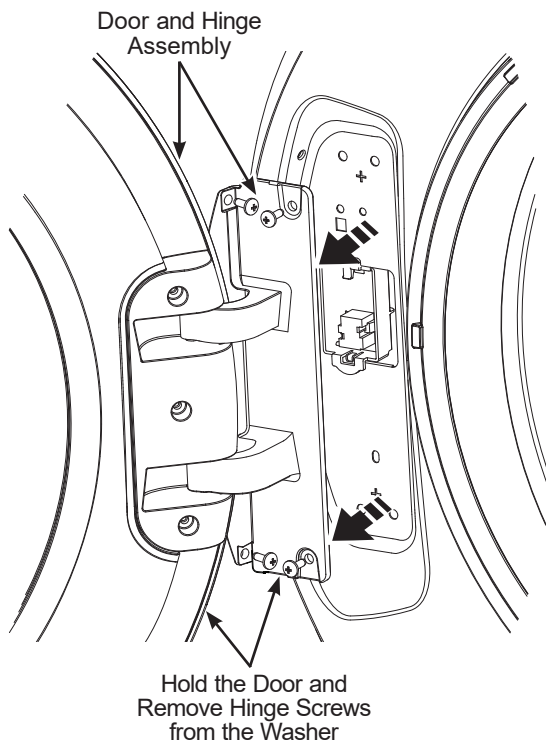

2 REMOVE THE DOOR HINGE COVER AND THE DOOR HINGE

- Remove the 3 screws from the hinge cover and remove the cover.
- Remove the 6 screws from the hinge and remove the hinge from the door.

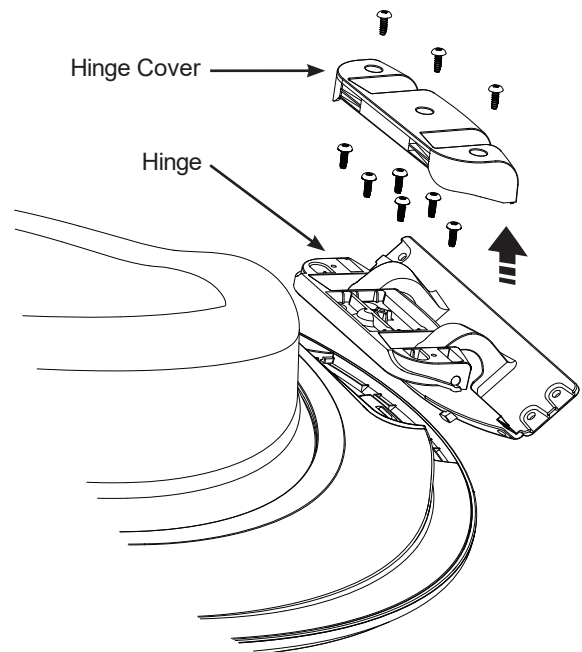

Installation Instructions

REVERSING THE DOOR SWING (Optional)

3 REMOVE, REVERSE AND REPLACE THE DOOR STRIKER

- Remove the 2 screws from the striker. Rotate the striker 180° and reinstall the striker with its screws.

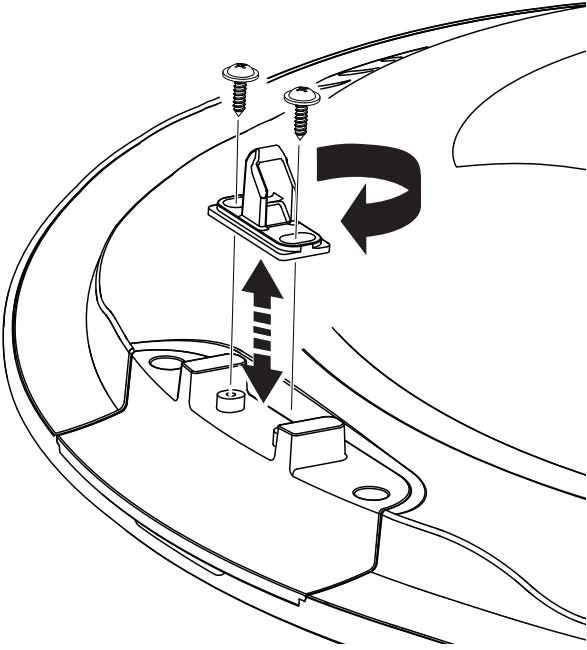

4 REMOVE THE DOOR STRIKER ASSEMBLY AND REPLACE ON THE OPPOSITE SIDE

- Remove the 2 screws from the striker assembly and remove the assembly by pulling it toward the center, pushing it up and pulling it out.

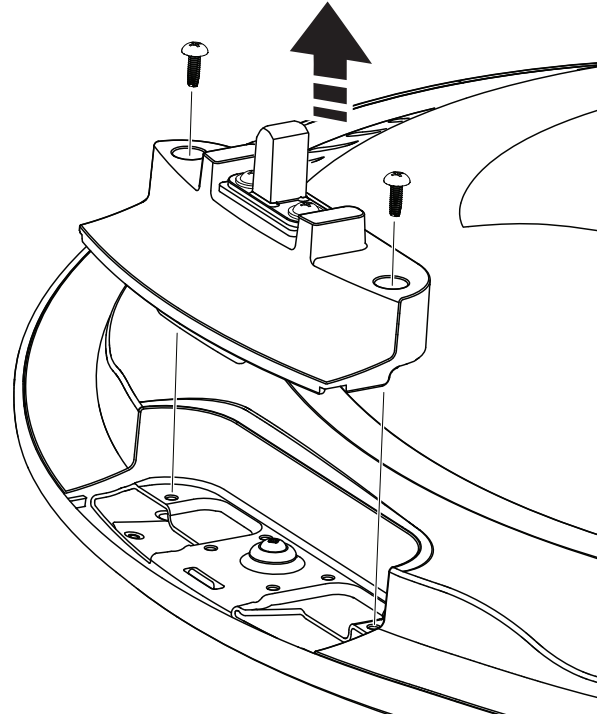

- Rotate the striker assembly and replace it on the opposite side with its screws.

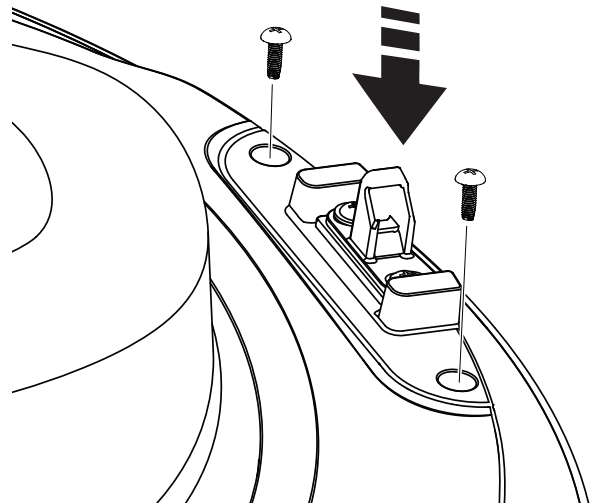

Installation Instructions

REVERSING THE DOOR SWING (Optional)

5 REPLACE THE DOOR HINGE AND THE DOOR HINGE COVER ON THE OPPOSITE SIDE

- Rotate the door hinge and replace it on the opposite side with its screws.
- Rotate the door hinge cover and replace it on the opposite side with its screws.

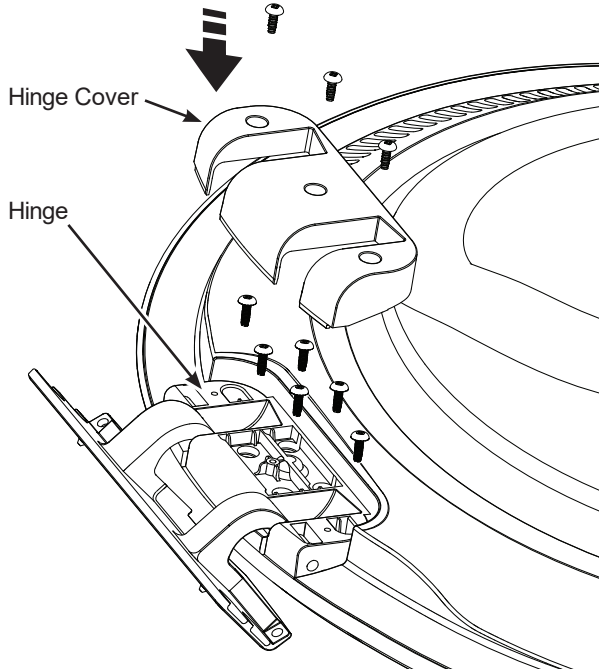

6 REMOVE THE TERMINAL HOLDER AND DISCONNECT THE PIN CONNECTOR FROM WASHER

- Using your fingers, pry the terminal holder from the washer face.
- Disconnect the pin connector.

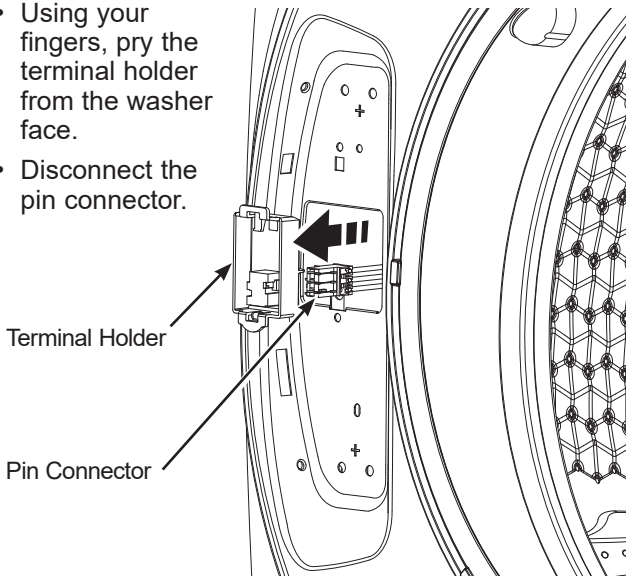

7 REMOVE LOCK ASSEMBLY AND INSTALL ON OPPOSITE SIDE OF WASHER

- Remove the 2 screws from the lock cover and remove it from the washer face.

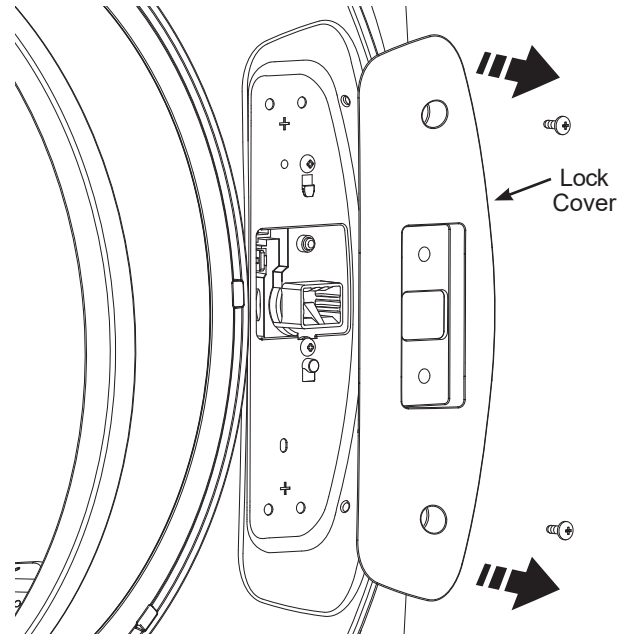

- Insert the provided lock bar into the lock mechanism in the washer face. Remove the lock assembly by removing its two screws, using the lock bar to lift it up to unhook, tilting and pulling it out of the washer face. Disconnect its pin connector by unsnapping its locks.

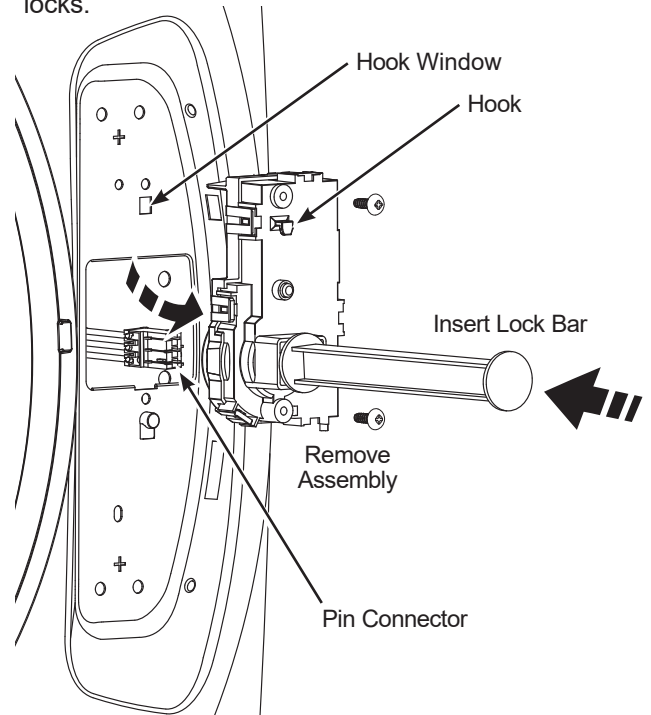

Installation Instructions

REVERSING THE DOOR SWING (Optional)

7 REMOVE LOCK ASSEMBLY AND INSTALL ON OPPOSITE SIDE OF WASHER (CONTINUED)

- Do **NOT** rotate lock assembly. Move it to the opposite side of the washer and connect the pin connector making sure it is fully snap locked together. Tilt and insert the lock assembly into the washer face, lift it up and latch its hook into its window. Replace its screws. Remove the lock bar from the assembly and retain for future use.

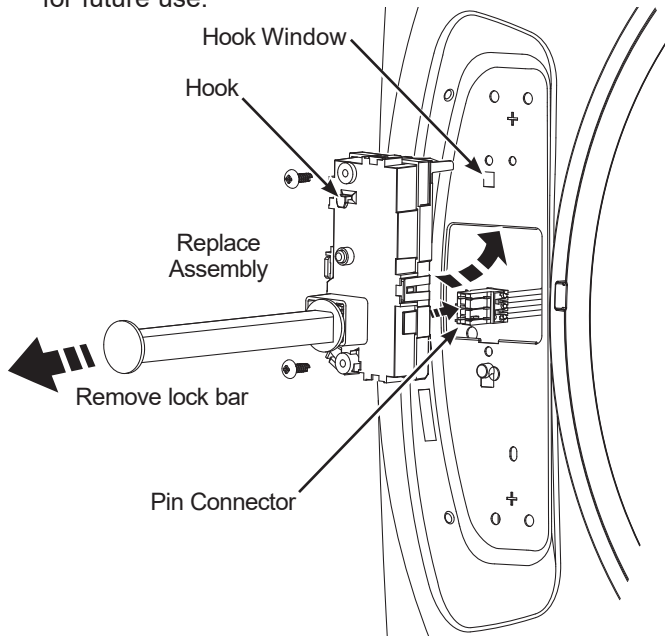

- Install the lock cover over the lock assembly, making sure the locating post fits into the locating hole and that the lock switch operates freely. Replace its screws.

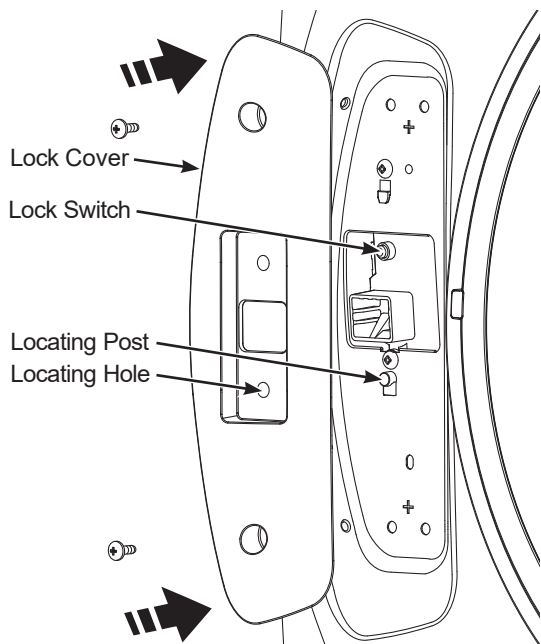

8 RECONNECT PIN CONNECTOR FROM THE WASHER AND REPLACE THE TERMINAL HOLDER

- Reconnect the pin connector and press the terminal holder back into the washer face on the opposite side.

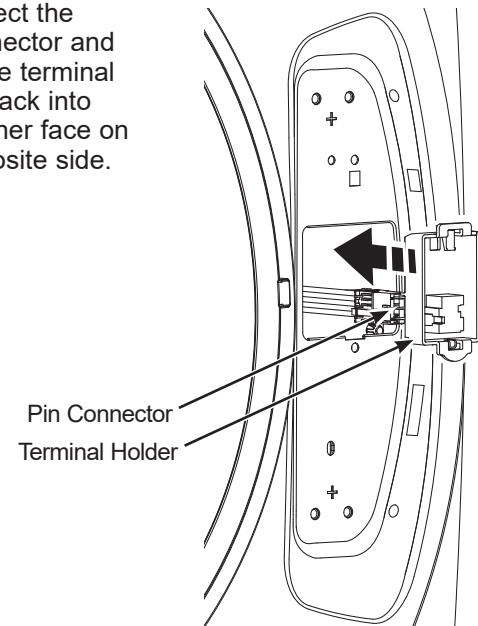

9 REPLACE THE DOOR ASSEMBLY

- Lift the door assembly into place and secure it onto the washer face with its 4 screws.

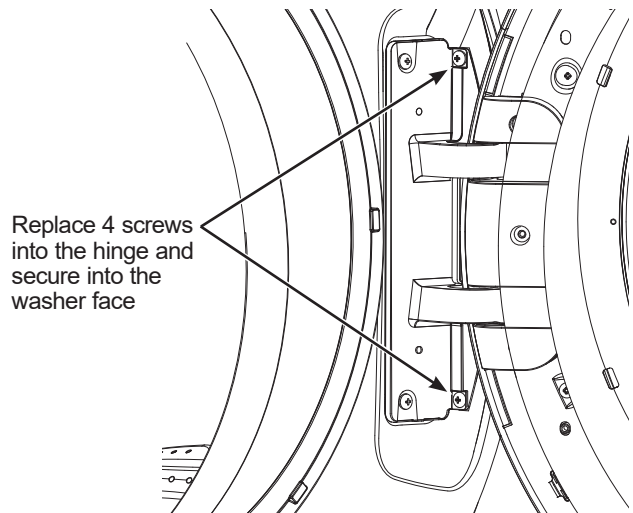

- Close the washer door.
NOTE: Make sure the door opens and closes correctly. If not, repeat all steps making sure all parts and screws are securely seated.
- Connect power cord and turn on the breaker.
- Run the washer through a complete cycle to verify proper operation.

Troubleshooting Tips... Before you call for service

Problem	Possible Cause	What To Do
Not draining Not spinning Not tumbling	Load is out of balance	Redistribute clothes and run Rinse & Spin . Increase load size if washing small load containing heavy and light items.
	Pump filter may be clogged	See the Care and Cleaning section on how to clean the Pump Filter .
	Drain hose is kinked or improperly connected	Straighten drain hose and make sure washer is not sitting on it.
	Household drain may be clogged	Check household plumbing. You may need to call a plumber.
	Drain hose siphoning; drain hose pushed too far down the drain	Ensure there is an air gap between hose and drain.
Leaking water	Door gasket is damaged	Check to see if gasket is seated and not torn. Objects left in pockets may cause damage to the washer (nails, screws, pens, pencils) Water may drip from the door when the door is opened. This is a normal operation. Carefully wipe off rubber door seal. Sometimes dirt or clothing is left in this seal and can cause a small leak
	Check back left of washer for water	If this area is wet, you have oversudsing condition. Use less detergent.
	Fill hoses or drain hose is improperly connected	Make sure hose connections are tight at washer and faucets and make sure end of drain hose is correctly inserted in and secured to drain facility.
	Household drain may be clogged	Check household plumbing. You may need to call a plumber.
	Dispenser clogged	Powder soap may cause clogs inside the dispenser and cause water to leak out the front of the dispenser. Remove drawer and clean both drawer and inside of dispenser box. Please refer to Care and Cleaning section.
	Incorrect use of detergent	Use only HE and correct amount of detergent.
	Dispenser box cracked	If new installation, check for crack on inside of dispenser box.
Clothes too wet	Load is out of balance	Redistribute clothes and run Rinse & Spin .
		Increase load size if washing small load containing heavy and light items.
		The machine will slow the spin speed down to 410 rpm if it has a hard time balancing the load. This speed is normal.
	Pump filter may be clogged	See the Care and Cleaning section on how to clean the Pump Filter .
	Overloading	The dry weight of the load should be less than 16 lbs.
	Drain hose is kinked or improperly connected	Straighten drain hose and make sure washer is not sitting on it.
	Household drain may be clogged	Check household plumbing. You may need to call a plumber.
Drain hose siphoning; drain hose pushed too far down the drain	Ensure there is an air gap between hose and drain.	

Troubleshooting Tips... Before you call for service

Problem	Possible Cause	What To Do
Incomplete cycle or timer not advancing	Automatic load redistribution	Timer adds up to 3 minutes to cycle for each rebalance. 11 or 15 rebalances may be done. This is normal operation. Do nothing; the machine will finish the wash cycle.
	Pump filter may be clogged	See the Care and Cleaning section on how to clean the Pump Filter .
	Drain hose is kinked or improperly connected	Straighten drain hose and make sure washer is not sitting on it.
	Household drain may be clogged	Check household plumbing. You may need to call a plumber.
	Drain hose siphoning; drain hose pushed too far down the drain	Ensure there is an air gap between hose and drain.
Loud or unusual noise; vibration or shaking	Cabinet moving	Washer is designed to move 1/4" to reduce forces transmitted to the floor. This movement is normal.
	All rubber leveling legs are not firmly touching the floor	Push and pull on the back right and then back left of your washer to check if it is level. If the washer is uneven, adjust the rubber leveling legs so they are all firmly touching the floor and locked in place.
	Unbalanced load	Pause unit, open door and manually redistribute load. To check machine, run rinse and spin with no load. If normal, unbalance was caused by load.
	Pump filter may be clogged	See the Care and Cleaning section on how to clean the Pump Filter .
No power/washer not working or dead	Washer is unplugged	Make sure cord is plugged securely into a working outlet.
	Water supply is turned off	Turn both hot and cold faucets fully on.
	Circuit breaker/fuse is tripped/blown	Check house circuit breakers/fuses. Replace fuses or reset breaker. Washer should have separate outlet.
	Automatic self system checks	First time the washer is plugged in, automatic checks occur. It may take up to 20 seconds before you can use your washer. This is normal operation.
"H2O SUPPLY" appears in display	Water not entering washer	See the Consumer Help Indicator section for details.
"CAnCELEd" appears in display	Washer paused or stopped	See the Consumer Help Indicator section for details.
"door" appears in display	Door not fully closed or 3 cycles started without opening door in between	See the Consumer Help Indicator section for details.
Snags, holes, tears, rips or excessive wear	Overloaded	Do not exceed maximum recommended load sizes. See recommended maximum load sizes in the Loading section.
	Pens, pencils, nails, screws or other objects left in pockets	Remove loose items from pockets.
	Pins, snaps, hooks, sharp buttons, belt buckles, zippers and sharp objects left in pockets	Fasten snaps, hooks, buttons and zippers.
Control time wrong or changes	This is normal	During spin the washer may need to rebalance the load sometimes to reduce vibrations. When this happens, the estimated time is increased causing time left to increase or jump.

Troubleshooting Tips... Before you call for service

Problem	Possible Cause	What To Do
Not enough water	This is normal	Horizontal washers do not require the tub to fill with water like top-load washers.
Washer pauses or has to be restarted, or washer door is locked and will not open	Pump filter may be clogged	See the Care and Cleaning section on how to clean the Pump Filter .
Door unlocks or press Start and machine doesn't operate	This is normal	Front-load washers start up differently than top-load washers, and it takes several seconds to check the system. The door will lock and unlock.
	Incorrect operation	Simply open and close the door firmly; then press Start .
Water does not enter washer or enters slowly	Automatic self system checks	After Start is pressed, the washer does several system checks. Water will flow several seconds after Start is pressed.
	Water valve screens are stopped up	Turn off the water source and remove the water connection hoses from the upper back of the washer. Use a brush or toothpick to clean the screens in the machine. Reconnect the hoses and turn the water back on.
	Inlet hose screen washers are stopped up	Turn off the water source and remove the inlet hoses from the wall faucets. Use a brush or toothpick to clean the screen washers in the end of the hoses. Reconnect the hoses and turn the water back on.
	Pump filter may be clogged	See the Care and Cleaning section on how to clean the Pump Filter .
	Fill hoses may be kinked	Check that fill hoses are not kinked or clogged.
	Water supply is turned off	Turn on both hot and cold faucets fully.
	Energy efficiency	This is an energy-efficient washer. As a result, the temperature settings for this washer may be different than for a non-energy-efficient washer.
	Insufficient water supply	Make sure that the water supply is turned on. Make sure that the water faucets are turned to their completely open position.
	The washer door is open	The washer door must be closed for all washer cycle operations. If the door is opened during the washer operation, all functions will stop, including water filling.
	Incorrect fill hose connection	Make sure that the fill hoses connect the hot water supply to the hot inlet on the washer and the cold water supply to the cold inlet on the washer (hot to hot, cold to cold).
Wrinkling	Improper sorting	Avoid mixing heavy items (like work clothes) with light items (like blouses).
	Overloading	Load your washer so clothes have enough room to move freely.
	Incorrect wash cycle	Match cycle selection to the type of fabric you are washing (especially for easy care loads).
	Repeated washing in water that is too hot	Wash in warm or cold water.

Troubleshooting Tips... Before you call for service

Problem	Possible Cause	What To Do
Grayed or yellowed clothes	Not enough detergent	Use correct amount of detergent.
	Not using HE (high efficiency) detergent	Use only HE detergent.
	Hard water	Use hottest water safe for fabric.
		Use a water conditioner like Calgon brand or install a water softener.
	Water is not hot enough	Make sure water heater is delivering water at 120°–140°F (48°–60°C).
	Detergent is not dissolving	Try a liquid HE detergent.
Dye transfer	Sort clothes by color. If fabric label states wash separately, unstable dyes may be indicated.	
Colored spots	Incorrect use of fabric softener	Check fabric softener package for instructions and follow directions for using dispenser.
	Dye transfer	Sort whites or lightly colored items from dark colors.
		Promptly remove wash load from washer.
Water temperature is incorrect	Water supply is improperly connected	Make sure hoses are connected to correct faucets.
	House water heater is not set properly	Make sure house water heater is delivering water at 120°–140°F (48°–60°C).
Bad odor inside your Washer	Washer unused for a long time, not using recommended quality of HE detergent or used too much detergent	Regularly use ULTRAFRESH VENT between uses.
		In case of strong odor, you may need to run the Self Clean cycle more than once.
		Use only the amount of detergent recommended or adjust SmartDispense to LOW .
		Use only HE (high efficiency) detergent.
		Always remove wet items from the washer promptly after it stops running or use 1 Step Wash + Dry or Tumble Care .
		If you choose to not use the ULTRAFRESH VENT System, leave the door slightly open for the washer to air dry. Close supervision is necessary if this appliance is used by or near children. Do not allow children to play on or in this appliance.
Detergent leak	This is normal	It is normal operation to see detergent leak on door gasket about 20 seconds after filling the dispenser.
Improper dispensing of softener or bleach	Dispenser clogged	Monthly clean the dispenser drawer to remove buildup of chemicals.
	Softener or bleach is filled above the max line	Make sure to have the correct amount of softener.
Dispenser drawer not dispensing properly	Laundry detergent packet placed in dispenser drawer	Laundry detergent packets should not be used in the dispenser. They should only be added directly to the wash tub following the manufacturer's directions.
Pump running while washer is not in use	Clog in sump drain	This is normal. Drain sump is detecting an undesired water fill level from a potential open faucet. Shut off water valve and inspect water valve for blockage.

GE Appliances Washer Limited Warranty

LIMITED WARRANTY

GEAppliances.com

All warranty service is provided by our Factory Service Centers, or an authorized Customer Care® technician. To schedule service online, visit us at GEAppliances.com/service, or call GE Appliances at 800.GE.CARES (800.432.2737). Please have your serial number and your model number available when calling for service.

Servicing your appliance may require the use of the onboard data port for diagnostics. This gives a GE Appliances factory service technician the ability to quickly diagnose any issues with your appliance and helps GE Appliances improve its products by providing GE Appliances with information on your appliance. If you do not want your appliance data to be sent to GE Appliances, please advise your technician not to submit the data to GE Appliances at the time of service.

For the period of:	We will replace:
One year From the date of the original purchase	Any part of the washer which fails due to a defect in materials or workmanship. During this limited one-year warranty , we will also provide, free of charge , all labor and related service to replace the defective part.
Ten years From the date of the original purchase	The motor , if it should fail due to a defect in materials or workmanship. During this additional nine-year limited warranty , you will be responsible for any labor and related service costs.

What is not covered:

- Service trips to your home to teach you how to use the product.
- Improper installation, delivery or maintenance.
- Failure of the product if it is abused, misused, or used for other than the intended purpose or used commercially.
- Replacement of house fuses or resetting of circuit breakers.
- Products which are not defective or broken, or which are working as described in the Owner's Manual.
- Damage to the product caused by accident, fire, floods or acts of God.
- Incidental or consequential damage caused by possible defects with this appliance.
- Defects or damage due to operation in freezing temperatures.
- Damage caused after delivery.
- Product not accessible to provide required service.

EXCLUSION OF IMPLIED WARRANTIES

Your sole and exclusive remedy is product repair as provided in this Limited Warranty. Any implied warranties, including the implied warranties of merchantability or fitness for a particular purpose, are limited to one year or the shortest period allowed by law.

In the United States:

This limited warranty is extended to the original purchaser and any succeeding owner for products purchased for home use within the USA. If the product is located in an area where service by a GE Appliances Authorized Servicer is not available, you may be responsible for a trip charge or you may be required to bring the product to an Authorized GE Appliances Service location for service. In Alaska, the limited warranty excludes the cost of shipping or service calls to your home.

Some states do not allow the exclusion or limitation of incidental or consequential damages. This limited warranty gives you specific legal rights, and you may also have other rights which vary from state to state. To know what your legal rights are, consult your local or state consumer affairs office or your state's Attorney General.

Warrantor: GE Appliances, a Haier Company, Louisville, KY 40225

In Canada:

This limited warranty is extended to the original purchaser and any succeeding owner for products purchased in Canada for home use within Canada. If the product is located in an area where service by a GE Appliances Authorized Servicer is not available, you may be responsible for a trip charge or you may be required to bring the product to an Authorized GE Appliances Service location.

Some provinces do not allow the exclusion or limitation of incidental or consequential damages. This limited warranty gives you specific legal rights, and you may also have other rights which vary from province to province. To know what your legal rights are, consult your local or provincial consumer affairs office.

Warrantor: MC Commercial Inc., Burlington, ON, L7R 5B6

Extended Warranties: Purchase a GE Appliances extended warranty and learn about special discounts that are available while your warranty is still in effect. You can purchase it online anytime at

GEAppliances.com/extended-warranty

or call 800.626.2224 during normal business hours. GE Appliances Service will still be there after your warranty expires.

Staple your receipt here. Proof of the original purchase date is needed to obtain service under the warranty.

Consumer Support

GE Appliances Website

Have a question or need assistance with your appliance? Try the GE Appliances Website 24 hours a day, any day of the year! You can also shop for more great GE Appliances products and take advantage of all our on-line support services designed for your convenience. In the US: GEAppliances.com.

In Canada: GEAppliances.ca.

Register Your Appliance

Register your new appliance on-line at your convenience! Timely product registration will allow for enhanced communication and prompt service under the terms of your warranty, should the need arise. You may also mail in the pre-printed registration card included in the packing material. In the US: GEAppliances.com/register.

In Canada: Prodsupport.mabe.ca/crm/Products/ProductRegistration.aspx.

Schedule Service

Expert GE Appliances repair service is only one step away from your door. Get on-line and schedule your service at your convenience any day of the year. In the US: GEAppliances.com/service or call 800.432.2737 during normal business hours.

In Canada: GEAppliances.ca/en/support/service-request or call 800.561.3344.

Extended Warranties

Purchase a GE Appliances extended warranty and learn about special discounts that are available while your warranty is still in effect. You can purchase it on-line anytime. GE Appliances Services will still be there after your warranty expires. In the US: GEAppliances.com/extended-warranty or call 800.626.2224 during normal business hours.

In Canada: GEAppliances.ca/en/support/purchase-extended-warranty or call 866.277.9842.

Remote Connectivity

For assistance with wireless network connectivity (for models with remote enable), in the US visit our website at GEAppliances.com/connect or call 800.220.6899.

In Canada: GEAppliances.ca/connect or call 800.220.6899.

Parts and Accessories

Individuals qualified to service their own appliances can have parts or accessories sent directly to their homes (VISA, MasterCard and Discover cards are accepted). Order on-line today 24 hours every day.

In the US: GEApplianceparts.com or by phone at 877.959.8688 during normal business hours.

In Canada: GEAppliances.ca/en/products/parts-filters-accessories or call 800.661.1616.

Instructions contained in this manual cover procedures to be performed by any user. Other servicing generally should be referred to qualified service personnel. Caution must be exercised, since improper servicing may cause unsafe operation.

Contact Us

If you are not satisfied with the service you receive from GE Appliances, contact us on our Website with all the details including your phone number, or write to:

In the US: General Manager, Customer Relations | GE Appliances, Appliance Park | Louisville, KY 40225
GEAppliances.com/contact or call 800.626.2000

In Canada: Director, Consumer Relations, MC COMMERCIAL INC. | Suite 310, 1 Factory Lane | Moncton, N.B. E1C 9M3
GEAppliances.ca/en/contact-us or call 877.994.5366
