



DISTINCT BY DESIGN™

Owner's Manual and Installation Instructions

Bottom Freezer Refrigerators

Models CVE and CQE

Contents

Safety Information	3	Troubleshooting	41
Using the Refrigerator		Normal Operating Conditions	41
Features	6	Troubleshooting Tips	42
Controls	9	Truth or Myth	44
Dispenser	12	Limited Warranty	46
AutoFill	12	Consumer Support	
WiFi	13	XWFE Water Filter Cartridge	
Demand Response	14	Limited Warranty	47
Water Filter	15	Performance Data Sheet	48
Refrigerator Storage	16	Consumer Support	50
Automatic Icemaker	21		
Care And Cleaning	22		
Replacing the Lights	23		
Installation Instructions			
Preparing to Install the Refrigerator	24		
Installing the Refrigerator	28		
Installing the Water Line	38		

Write the model and serial numbers here:

Model # _____

Serial # _____

Find these numbers on a label on the left side, near the middle of the refrigerator compartment.

ENGLISH/FRANÇAIS/ESPAÑOL

THANK YOU FOR MAKING CAFÉ A PART OF YOUR HOME.

We take pride in the craftsmanship, innovation and design that goes into every Café product, and we think you will too. Among other things, registration of your appliance ensures that we can deliver important product information and warranty details when you need them.

Register your Café appliance now online. Helpful websites are available in the Consumer Support section of this Owner's Manual. You may also mail in the pre-printed registration card included in the packing material.

C A F É

DISTINCT BY DESIGN™

IMPORTANT SAFETY INFORMATION

READ ALL INSTRUCTIONS BEFORE USING THE APPLIANCE

▲ WARNING To reduce the risk of fire, explosion, electric shock, or injury when using your refrigerator, follow these basic safety precautions:

- This refrigerator must be properly installed and located in accordance with the Installation Instructions before it is used.
- Unplug the refrigerator before making repairs or cleaning.
NOTE: Power to the refrigerator cannot be disconnected by any setting on the control panel.
NOTE: Repairs must be performed by a qualified Service Professional.
- Replace all parts and panels before operating.
- Do not use an extension cord.
- Keep flammable materials and vapors away from the refrigerator.
- Do not store explosive substances such as aerosol cans with a flammable propellant in this appliance.
- To prevent suffocation and entrapment hazards to children, remove the refrigerator and freezer doors from any refrigerator before disposing of it or discontinuing its use.
- To avoid serious injury or death, children should not stand on, or play in or with the appliance.
- Children and persons with reduced physical, sensory or mental capabilities or lack of experience and knowledge can use this appliance only if they are supervised or have been given instructions on safe use and understand the hazards involved.
- This appliance is intended to be used in household and similar applications such as: staff kitchen areas in shops, offices and other working environments; farm houses; by clients in hotels, motels, bed & breakfast and other residential environments; catering and similar non-retail applications.
- Connect to potable water supply only. A cold water supply is required for automatic icemaker operation. The water pressure must be between 40 and 120 psi (275-827 kilopascals).
- Do not apply harsh cleaners to the refrigerator. Certain cleaners will damage plastic which may cause parts such as the door or door handles to detach unexpectedly. See the Care and Cleaning section in your Owner's Manual for detailed instructions.

▲ CAUTION To reduce the risk of injury when using your refrigerator, follow these basic safety precautions.

- Do not clean glass shelves or covers with warm water when they are cold. Glass shelves and covers may break if exposed to sudden temperature changes or impact, such as bumping or dropping. Tempered glass is designed to shatter into many small pieces if it breaks.
- Keep fingers out of the "pinch point" areas; clearances between the doors and between the doors and cabinet are necessarily small. Be careful closing doors when children are in the area.
- Do not touch the cold surfaces in the freezer compartment when hands are damp or wet, skin may stick to these extremely cold surfaces.
- Do not refreeze frozen foods which have thawed completely.
- In refrigerators with automatic icemakers, avoid contact with the moving parts of the ejector mechanism, or with the heating element that releases the cubes. Do not place fingers or hands on the automatic ice making mechanism while the refrigerator is plugged in.

▲ WARNING FIRE OR EXPLOSION HAZARD

Keep flammable materials and vapors away from refrigerator. Failure to do so can result in fire, explosion, or death.

READ AND SAVE THESE INSTRUCTIONS

IMPORTANT SAFETY INFORMATION

READ ALL INSTRUCTIONS BEFORE USING THE APPLIANCE

⚠ WARNING FIRE OR EXPLOSION HAZARD Flammable Refrigerant

This appliance contains isobutane refrigerant, also known as R600a, a natural gas with high environmental compatibility. However, it is also combustible. Adhere to the warnings below to reduce the risk of injury or property damage.

1. When handling, installing and operating the appliance, care should be taken to avoid damage to the refrigerant tubing.
2. Service shall only be performed by authorized service personnel. Use only manufacturer-authorized service parts.
3. Dispose of refrigerator in accordance with Federal and Local Regulations. Flammable refrigerant and insulation material used require special disposal procedures. Contact your local authorities for the environmentally safe disposal of your refrigerator.
4. Keep ventilation openings in the appliance enclosures or in the built-in structure clear of obstruction.
5. To remove frost, scrape with a plastic or wood spatula or scraper. Do not use an ice pick, metal, or sharp-edged instrument as it may puncture the freezer liner and then the flammable refrigerant tubing behind it.
6. Do not use electrical appliances inside the food storage compartment of the appliance.
7. Do not use any electrical device in defrosting your freezer.

CONNECTING ELECTRICITY

⚠ WARNING ELECTRICAL SHOCK HAZARD

Plug into a grounded 3-prong outlet

Do not remove the ground prong

Do not use an adapter

Do not use an extension cord.

Failure to follow these instructions can result in death, fire, or electrical shock.

Do not, under any circumstances, cut or remove the third (ground) prong from the power cord. For personal safety, this appliance must be properly grounded.

The power cord of this appliance is equipped with a 3-prong (grounding) plug which mates with a standard 3-prong (grounding) wall outlet to minimize the possibility of electric shock hazard from this appliance.

Have the wall outlet and circuit checked by a qualified electrician to make sure the outlet is properly grounded.

Where a standard 2-prong wall outlet is encountered, it is your personal responsibility and obligation to have it replaced with a properly grounded 3-prong wall outlet. Do not use an adapter.

The refrigerator should always be plugged into its own individual electrical outlet which has a voltage rating that matches the rating plate.

A 115 Volt AC, 60 Hz, 15- or 20-amp fused, grounded electrical supply is required. This provides the best performance and also prevents overloading house wiring circuits which could cause a fire hazard from overheated wires.

Never unplug your refrigerator by pulling on the power cord. Always grip plug firmly and pull straight out from the outlet.

Immediately discontinue use of a damaged supply cord. If the supply cord is damaged, it must be replaced by a qualified service professional with an authorized service part from the manufacturer.

When moving the refrigerator away from the wall, be careful not to roll over or damage the power cord.

READ AND SAVE THESE INSTRUCTIONS

IMPORTANT SAFETY INFORMATION

READ ALL INSTRUCTIONS BEFORE USING THE APPLIANCE

PROPER DISPOSAL OF YOUR OLD REFRIGERATOR

⚠ DANGER SUFFOCATION AND ENTRAPMENT HAZARD

Failure to follow these disposal instructions can result in death or serious injury

IMPORTANT: Child entrapment and suffocation are not problems of the past. Junked or abandoned refrigerators are still dangerous even if they will sit for “just a few days.” If you are getting rid of your old refrigerator, please follow the instructions below to help prevent accidents.

Before You Throw Away Your Old Appliance

- Take off the refrigerator and freezer doors.
- Leave the shelves in place so that children may not easily climb inside.

Refrigerant and Foam Disposal:

Dispose of appliance in accordance with Federal and Local Regulations. Flammable refrigerant and insulation material used requires special disposal procedures. Contact your local authorities for the environmentally safe disposal of your refrigerator.

READ AND SAVE THESE INSTRUCTIONS

Features

Model CVE

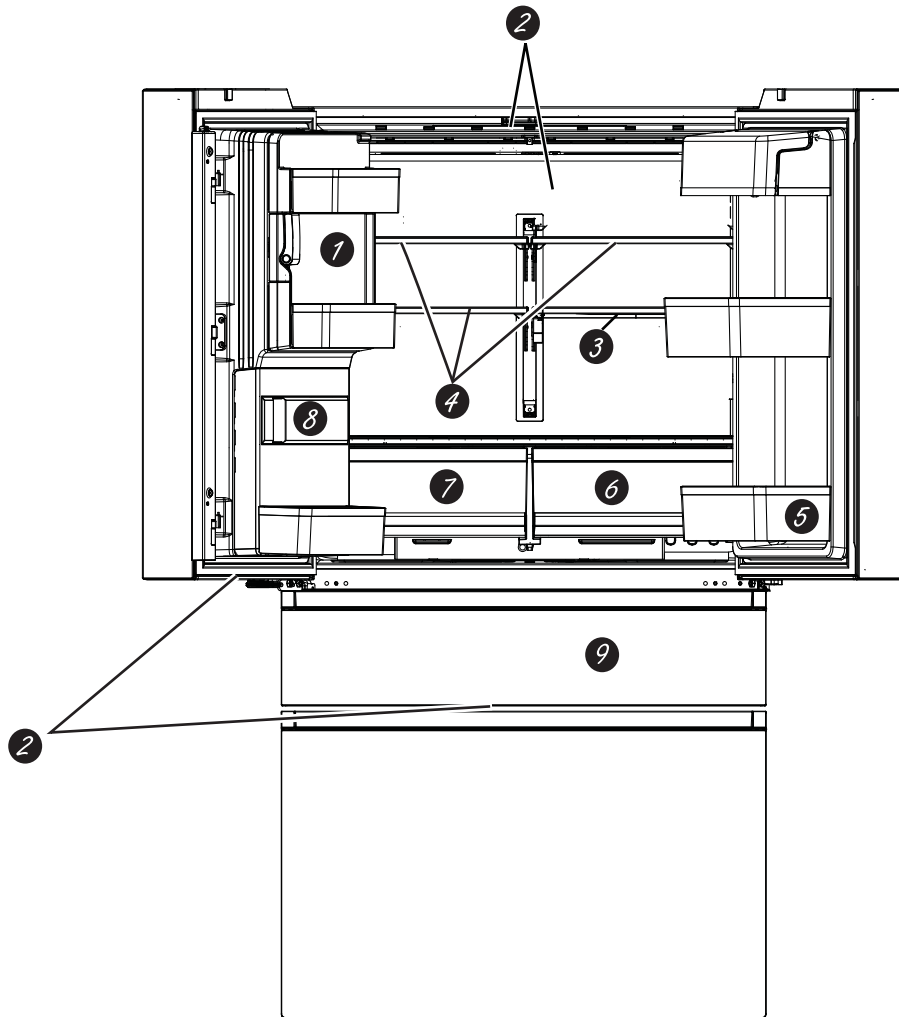

- 1 Space-saving ice maker**
Ice maker and bin are located on the door creating more usable storage space.
- 2 Showcase LED lighting**
LED lighting is positioned throughout the interior to spotlight areas in the refrigerator. LEDs are located under the fresh food door to light the convertible drawer, and LEDs are under the convertible drawer to light the freezer drawer.
- 3 QuickSpace™ shelf**
Functions as a normal full-sized shelf when needed and easily slides back to store tall items below.
- 4 Spillproof shelves**
Designed to capture your spills for easier clean up.
- 5 Removable door bin**
Can be removed for those with a wall limiting the door opening.
- 6 HCS (Humidity Control System)**
Sealed HCS bin prolongs produce preservation by maintaining humidity in the bin.
- 7 Vented Bin**
Vented bin for storing fruits and vegetables.
- 8 Water filter**
Filters water and ice.
- 9 Convertible drawer**
Select the best temperature to store your food.

Features

Model CQE

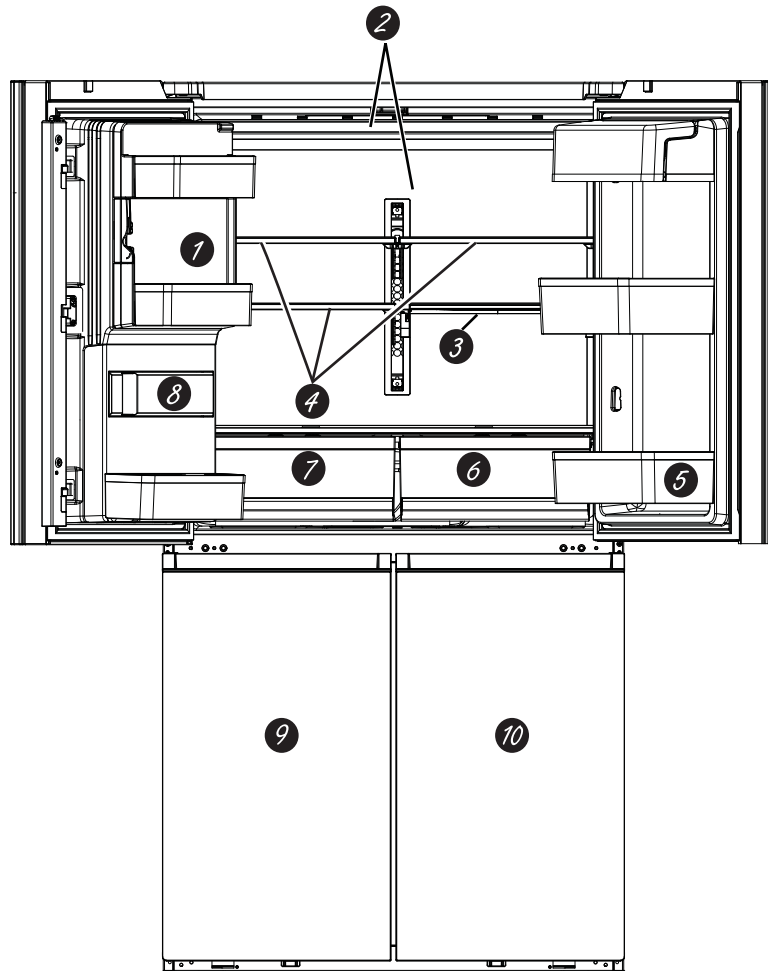

1 Space-saving ice maker

Ice maker and bin are located on the door creating more usable storage space.

2 Showcase LED lighting

LED lighting is positioned throughout the interior to spotlight areas in the refrigerator.

3 QuickSpace™ shelf

Functions as a normal full-sized shelf when needed and easily slides back to store tall items below.

4 Spillproof shelves

Designed to capture your spills for easier clean up.

5 Removable door bin

Can be removed for those with a wall limiting the door opening.

6 HCS (Humidity Control System)

Sealed HCS bin prolongs produce preservation by maintaining humidity in the bin.

7 Vented Bin

Vented bin for storing fruits and vegetables.

8 Water filter

Filters water and ice.

9 Freezer

Compartment for storing your frozen food. The middle and bottom door bins tilt-out for easy access.

10 Convertible Zone

Compartment that can store frozen food, fresh food, or wine.

Features

Door ice bin

1. Open left refrigerator door.
2. Pull down latch to release bin door.
3. Using handhold lift ice bucket up and out to clear locators in bottom of bin.
4. To replace the ice bucket, set it on the guide brackets and push until the ice bucket seats properly.
5. If bucket cannot be replaced, rotate the Ice Bucket Fork 1/4 turn clockwise.

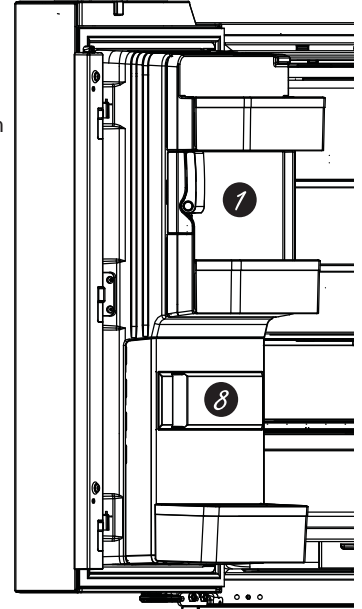
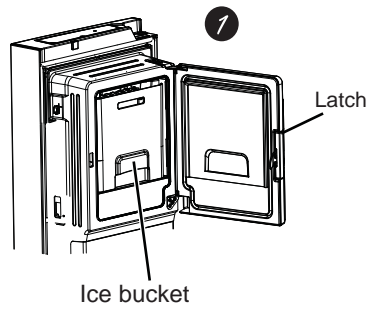

Ice/water filter

Certified to reduce chlorine-resistant cysts, lead, select pharmaceuticals, and more. For easy filter replacement instructions see page 10.

Freezer door bin

Middle and bottom bins on the freezer door can be tilted out for easy access.

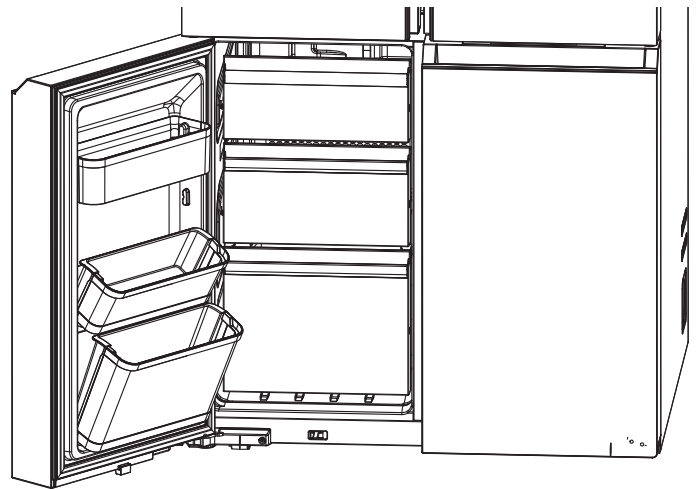

Controls

All Models

We are continuously updating our software. Please reference the full owner's manual online for the latest functionality at cafeappliances.com. In Canada, visit cafeappliances.ca.

The recommended temperature settings, preset from the factory, are 37°F (3°C) for the refrigerator and 0°F (-18°C) for the freezer.

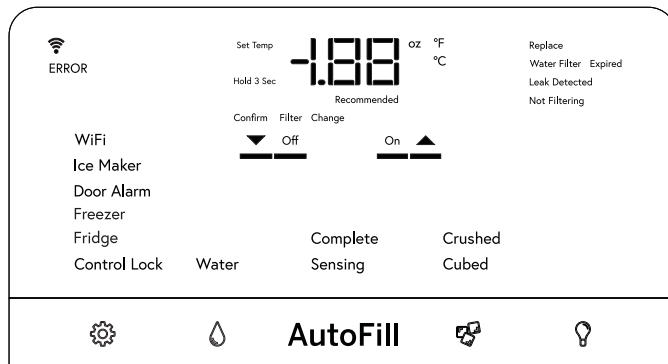

NOTE: The refrigerator is shipped with protective film covering the temperature controls. If this film was not removed during installation, remove it now.

The temperature controls are preset in the factory at 37°F (3°C) for the refrigerator compartment and 0°F (-18°C) for the freezer compartment. Allow 24 hours for the temperature to stabilize to the preset recommended settings.

To Change the Refrigerator Temperature:

Press the **Settings** button (⚙️) until “Fridge” is highlighted. Press the Up or Down arrow buttons to increase or decrease temperature settings.

To Change the Freezer Temperature:

Press the Settings button (⚙️) until “Freezer” is highlighted. Press the Up or Down arrow buttons to increase or decrease temperature settings.

The cooling system can be turned off by pressing the Settings button (⚙️) until either “Fridge” or “Freezer” is highlighted. Press and hold both the Up and Down arrow buttons for 3 seconds. “- -” will be displayed when the system is off. Turning the cooling system off stops the cooling to the refrigerator, but it does not shut off the electrical power. The cooling system can be turned on by returning to the “Fridge” or “Freezer” setting and pressing the On button.

Control Settings

Settings (⚙️) - Press the Settings symbol (⚙️) to scroll through the refrigerator functions.

- Control Lock - Press ON to lock out ice and water dispenser and all feature and temperature buttons. Press and hold OFF for 3 seconds to deactivate.
- Fridge - Press Up or Down button to increase or decrease temperature from 34°F (1°C) to 42°F (6°C).

- Freezer - Press Up or Down button to increase or decrease temperature from -6°F (-21°C) to 5°F (-15°C).
- Door Alarm - Sounds an alert when the freezer or refrigerator doors have been left open. Snooze the alert by pressing any key. Press On or Off to activate or deactivate Door Alarm while an alert is not active.
- Icemaker - Press On or Off to start/stop Icemaker.
- WiFi - Press **On** to start the WiFi connection process per the instructions on Page 13. Press **Off** to disable WiFi. Note that restarting WiFi requires repeating the WiFi connection process.

Water (💧) - Press to select Ice or Water to dispense when the paddle is pressed.

AutoFill - Press to initiate automatic sensing to fill from dispenser.

Ice (🧊) - Press to select crushed or cubed ice when the paddle is pressed.

Light (💡) - Press to illuminate dispenser. Chime will accompany each press.

Fahrenheit / Celsius:

Temperature display can be switched between Fahrenheit and Celsius. Press Settings button (⚙️) to navigate to “Fridge” or “Freezer”, then press and hold the Ice button and Light button for three seconds.

Volume Control:

Alert volume can be adjusted from High to Low and Off. Press Settings button (⚙️) to navigate to “Icemaker”, then press and hold the Ice button and Light button for three seconds.

Sabbath Mode:

Simultaneously hold the Settings (⚙️), Water, and Light buttons for three seconds to enter and exit Sabbath mode. Display will show “SA” and mode will automatically exit after 3 days.

Controls

Model CVE Convertible Drawer

Temperature in the Convertible Drawer is selected by pressing the food item to be kept in the drawer.

Soft Freeze	23°F (-5°C)
Meat	29°F (-2°C)
Beverages	33°F (1°C)
Snacks	37°F (3°C)
Wine	42°F (6°C)

The temperature setting is locked by default. Button must be pressed for 3 seconds to unlock.

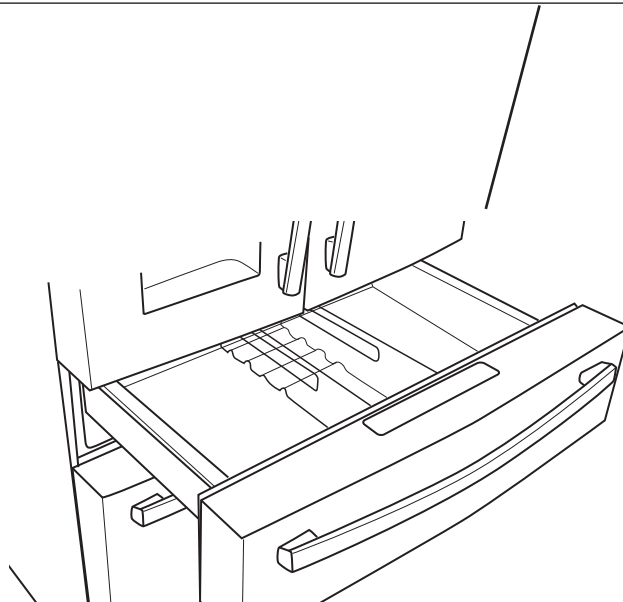
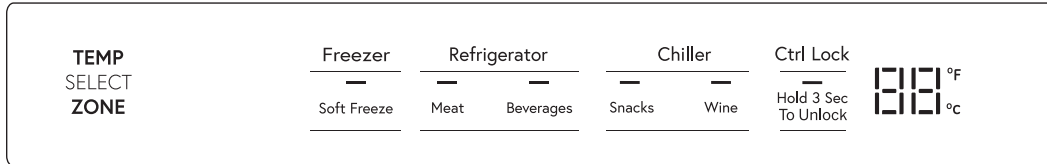

Controls

Model CQE Convertible Zone

The Convertible Zone control panel is in the top of the lower right-hand door. Select the desired temperature for the compartment.

- Freezer 0°F (-18°C)
- Refrigerator 37°F (3°C)
- Chiller 42°F (6°C)

The temperature setting is locked by default. Button must be pressed for 3 seconds to unlock.

The Warmer (+) and Cooler (-) buttons can be used to adjust the temperature of each setting.

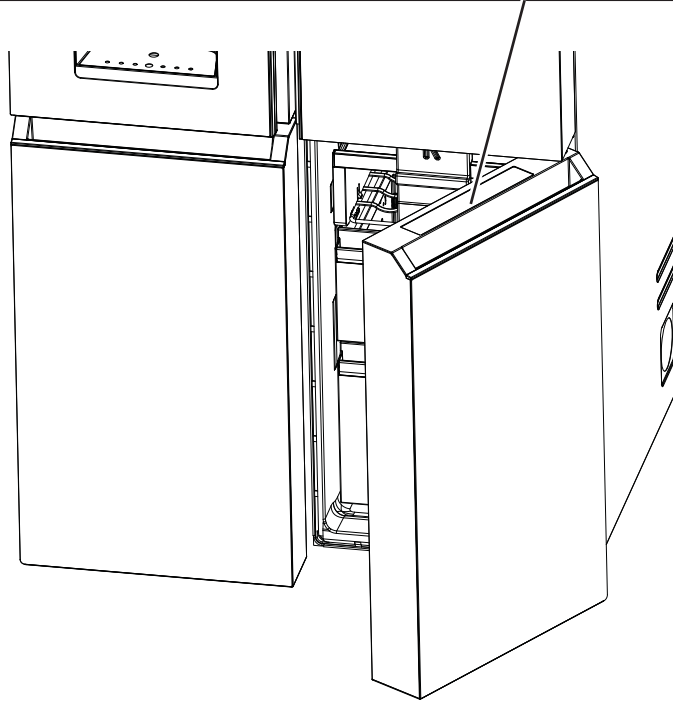
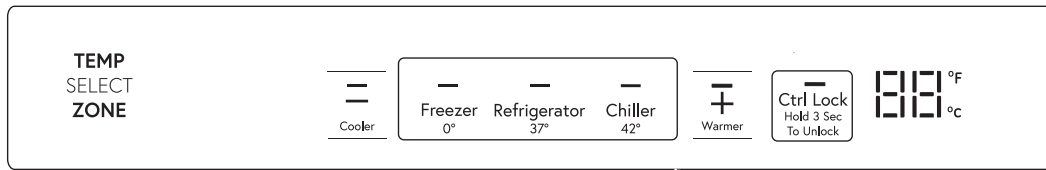

Dispenser

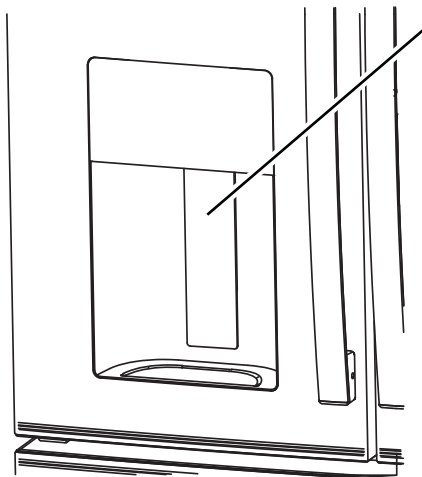

Water & Ice Dispenser
(See About the controls with temperature settings & About the control features)

▲ WARNING Laceration Hazard

- Never put fingers or any other object into ice crusher discharge opening. Doing so can result in contacting the ice crushing blades and lead to serious injury or amputation
- Use a sturdy glass when dispensing ice. A delicate glass may break and result in personal injury.

If no water is dispensed when the refrigerator is first installed, there may be air in the water line system. Press the dispenser paddle for at least five minutes to remove trapped air from the water line and to fill the water system. To flush out impurities in the water line, throw away the first six full glasses of water.

Important Facts About Your Dispenser

- Do not add ice from trays or bags to the door icemaker bucket. It may not crush or dispense.
- Avoid overfilling glass with ice and use of narrow glasses. Backed-up ice can jam the chute or cause the door in the chute to freeze shut. If ice is blocking the chute remove the ice bucket, poke it through with a wooden spoon.
- Beverages and foods should not be quick-chilled in the door icemaker bin. Cans, bottles or food packages in the storage drawer may cause the icemaker or auger to jam.
- To keep dispensed ice from missing the glass, put the glass close to, but not touching, the dispenser opening.
- Some crushed ice may be dispensed even though you selected **CUBED**. This happens occasionally when a few cubes accidentally get directed to the crusher.
- After crushed ice is dispensed, some water may drip from the chute.
- Sometimes a small mound of snow will form on the door in the ice chute. This condition is normal and usually occurs when you have dispensed crushed ice repeatedly. The snow will eventually evaporate.

AutoFill

To Use HANDS FREE AutoFill:

- Center container on Recess Dispenser Tray as far back as possible without activating paddle and remove hand from container
- Press **AutoFill**.

To Stop AutoFill

- Press ANY key, including **AutoFill**, to stop.

Important Facts about AutoFill

- For optimum results, use a uniform container between 4-8" (10-20 cm) tall and 2-6" (5-15 cm) wide.
- Fill level and functionality may vary on containers taller than 8" (20 cm) or wider than 6" (15 cm).
- Container volumes may vary. If "ERROR" message is given, try a different container.
- AutoFill will time out.
- Handles, straws, and garnishes on the rim of the container may cause overfilling or variation in fill volumes.
- Splashing may occur depending on the location of the container, water flow rate, container shape, and ice cubes.

- Keep sensors clean with a clean damp cloth, and do not spray liquid or cleaners directly on sensors
- AutoFill works best with household water pressure of 60 to 100 psi (414 to 689 kPa).
- Ice in container may affect fill volume. If issues are experienced, use less ice.

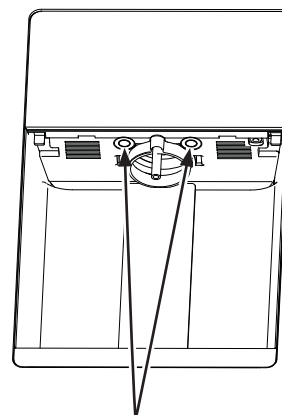

AutoFill Sensors

WiFi (for customers in the United States, its territories, and Canada)

- Download the **Café Appliances** app.
 - Available for iPhone from the Apple Store or from link at **GEAppliances.com**.
 - Available for Android from Google Play or from link at **GEAppliances.com**.
- Select **Create Account** on app.
 - Enter information, and select **Register**. An e-mail will be generated.
 - When you receive the e-mail, select **Verify Account**.
 - Sign in with your credentials and select **Authorize** to allow the app to communicate with your refrigerator.
- Set up the app.
 - Press the (+) on the bottom of the screen.
 - Choose **Fridge** (Cap Touch).
 - The info button will show a picture of the touch display on the appliance. Select **OK**.
 - Select **Next**.
- Select WiFi on the refrigerator display by pressing the **Settings symbol**.
 - Select **On**, the WiFi symbol will flash every second.
 - Select **Next** in the app.
- Find the password inside the refrigerator door on the “Connected Appliance Information” label.
 - Enter the password into the app.
- Connect to the refrigerator’s WiFi Module in the phone’s WiFi settings, then return back to the Kitchen App and select **Next**.
 - The WiFi will have the format “GE_MODULE_XXXX”. The module number can also be found on the Connected Appliance Information label inside the fridge door.
 - Connect to the home WiFi network and type in the home WiFi password.
 - If all check marks appear and the user gets a screen that says the device is connected, the device has been successfully connected.
 - If the app fails to connect, the user will also show an error on the refrigerator’s display where the LED will either be flashing or solid.
Select correct LED mode on the “Oops! Something Went Wrong” screen. The user will be given possible reasons why connection failed and the option to retry.

SOFTWARE UPDATES

One of the features of the Kitchen App is the ability to accept refrigerator software updates. When the user accepts the updates, refrigerator lights will appear to turn off, and all features are not be available during the update. This is normal behavior during software updates. Users are encouraged to check the refrigerator settings after an software update.

REGULATORY INFORMATION

FCC/IC Compliance Statement:

This device complies with Part 15 of the FCC Rules. Operation is subject to the following two conditions:

1. This device may not cause harmful interference, and
2. This device must accept any interference received, including interference that may cause undesired operation.

This equipment has been tested and found to comply with the limits for a Class B digital device, pursuant to Part 15 of the FCC Rules. These limits are designed to provide reasonable protection against harmful interference in a residential installation. This equipment generates uses and can radiate radio frequency energy and, if not installed and used in accordance with the instructions, may cause harmful interference to radio communications. However, there is no guarantee that interference will not occur in a particular installation. If this equipment does cause harmful interference to radio or television reception, which can be determined by turning the equipment off and on, the user is encouraged to try to correct the interference by one or more of the following measures:

- Reorient or relocate the receiving antenna.
- Increase the separation between the equipment and receiver.
- Connect the equipment into an outlet on a circuit different from that to which the receiver is connected.
- Consult the dealer or an experienced radio/television technician for help.

Labelling: Changes or modifications to this unit not expressly approved by the manufacturer could void the user’s authority to operate the equipment.

Demand Response (some models)

What is Demand Response?

Some utilities vary their electricity rates based on the time of day. Some utilities offer Demand Response programs to reduce energy usage during certain times of the day. Some utilities may do both things. This refrigerator has a Demand Response feature to help control energy usage.

Using Demand Response without a Utility Program

The Demand Response feature allows the user to shift high energy features, like defrost, for a 4-hour window. This window corresponds to the average peak energy usage. This feature is enabled or disabled with the Café Appliances app and requires the Café Appliances app to operate. It does not depend on the local utility, or whether it varies the electricity rates.

Demand Response with your Utility

If your utility has a compatible Demand Response program, and you are signed up with the utility, this refrigerator can modify its energy usage based on commands received from the utility. The Café Appliances app can be used to override the Demand Response program, if desired. Please note that there are many different Demand Response programs, and many are not compatible with kitchen appliances. Please check with your local utility.

The demand response level is displayed in the mobile app. Delay appliance load mode (DAL) reduces power consumption by delaying defrost and ice production for 4 hours. Temporary appliance load reduction (TALR) reduces the power consumption by delaying defrost, ice production, and stopping cooling for 10 minutes.

Estimated energy consumption in Watt-hour(Wh) is reported in the mobile app.

Installing Demand Response

Install the Café Appliances app per the instructions on the previous page. Select the Demand Response page, and choose from the available Demand Response options. The app provides more information on the operation of each Demand Response option.

Demand Response Communication Protocols

This refrigerator uses the following IETF open standard protocols for the WiFi communication. Consult the online user manual for the latest protocol updates:

- XMPP <https://tools.ietf.org/html/rfc6120>
- TLS <https://tools.ietf.org/html/rfc5246>

GEA API for demand response:

- Write demand respond status (Inactive, DAL, and TALR)
- Get demand response status (Inactive, DAL, TALR, or Delay Defrost)
- Get estimated energy consumption in Watt-hour.
- Get event for "Door Open"
- Get event for "High temperature alert"
- Write demand response (DAL or TALR) start time and duration time period.
- Get demand response (DAL or TALR) start time and duration time period.
- Delete demand response (DAL or TALR) schedule.

XWFE Water Filter

Water Filter Cartridge

The water filter cartridge is located in the left-hand refrigerator door behind the rectangular access panel.

When to Replace the Filter Cartridge

The **Replace Water Filter** message on the control panel will illuminate when the water filter cartridge needs to be replaced soon. The **Water Filter Expired** message will illuminate when the water filter cartridge needs to be replaced. The water filter can be replaced earlier if the flow of water to the dispenser or icemaker decreases. Once either message is illuminated, dispensing water will show **Confirm Filter Change**; do not confirm until the water filter is replaced

REMOVING THE FILTER

If you are replacing the filter, first remove the previous one by gently grasping the filter and slowly turning it to the left, about a ¼ turn. The filter should automatically release itself when you have rotated it far enough to the left. A small amount of water may drip down.

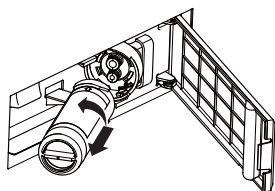
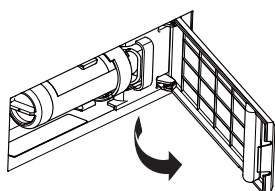

CAUTION

If air has been trapped in the system, the filter cartridge may be ejected as it is removed. Use caution when removing.

FILTER BYPASS PLUG

To reduce the risk of property damage due to water leakage, you **MUST** use the filter bypass plug when a replacement filter cartridge is not available. Some models do not come equipped with the filter bypass plug. To obtain a free bypass plug, visit cafeappliances.com. The dispenser and icemaker will not operate without either the filter or bypass plug installed. The bypass plug is installed in the same way as a filter cartridge.

INSTALLING THE FILTER IN A BOTTOM FREEZER REFRIGERATOR

1. Open the filter cartridge housing by pulling the door open.
2. Line up the ports on the filter with the ports on the filter cartridge holder, and gently insert the filter.
3. Slowly turn the filter to the right until it stops. **DO NOT OVERTIGHTEN**. As you turn the filter, it will automatically adjust itself into position. The filter will move about a ¼ turn or 90 degrees, until the filter cannot be turned, and the label faces outward.
4. Slowly push the filter up into the clips.
5. Close the filter cartridge housing by gently pushing the door closed until the tabs lock into place.
6. Run water from the dispenser for 2 gallons or approximately 5 minutes to clear the system. Water may spurt out and air bubbles may be visible during this process. If water is not flowing, check to make sure the filter has been fully rotated to the right.
7. When dispensing water, press the button underneath the **Confirm Filter Change** message. If replacing the water filter before the message appeared, press the Settings (⚙️) button until "Icemaker" is highlighted, then hold down the Water and Ice buttons simultaneously for 3 seconds.

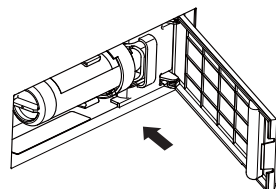
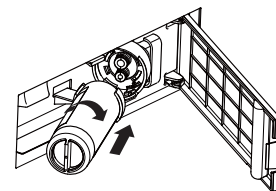

Application Guidelines/Water Supply

Service Flow	0.5 gpm (1.89 lpm)
Water Supply	Potable Water
Water Pressure	25-120 psi (172-827 kPa)
Water Temperature	33°F-100°F (0.6°C-38°C)
Capacity	170 gallons (643.5 liters)

Sign-up for **TEXT REMINDERS** by texting **REPLACE** to 70543.

WARNING

To reduce the risk associated with choking, do not allow children under 3 years of age to have access to small parts during the installation of this product. The disposable filter cartridge should be replaced every 6 months at the rated capacity, or sooner if a noticeable reduction in flow rate occurs.

For the maximum benefit of your filtration system, Café Appliances recommends the use of GE Appliances-branded filters only. Using GE Appliances-branded filters in Café refrigerators provides optimal performance and reliability. GE Appliances filters meet rigorous industry NSF standards for safety and quality that are important for products that are filtering your water. Café Appliances has not qualified non-GE Appliances-branded filters for use in Café refrigerators and there is no assurance that non-GE Appliances-branded filters meet Café standards for quality, performance and reliability.

If you have questions, or to order additional filter cartridges, visit our website at gewaterfilters.com. Customers in Canada should consult the yellow pages for the nearest Camco Service Center.

Refrigerator Storage Options

Rearranging the Shelves

Shelves in the refrigerator compartment are adjustable.

To remove:

- 1 Remove all items from the shelf.
- 2 Tilt the shelf up at the front.
- 3 Lift the shelf up at the back and bring the shelf out.

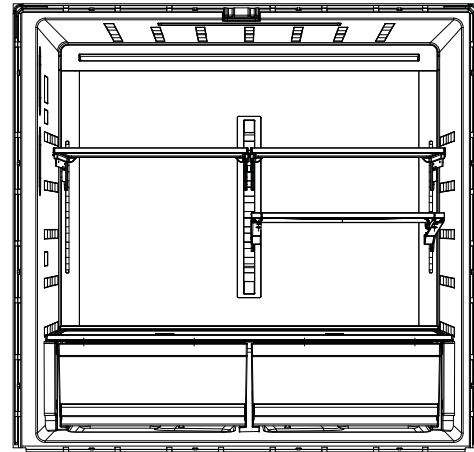
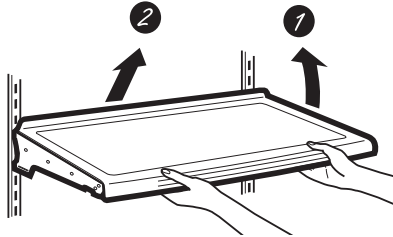

To replace:

- 1 While tilting the shelf up, insert the top hook at the back of the shelf in a slot on the track.
- 2 Lower the front of the shelf until the bottom of the shelf locks into place.

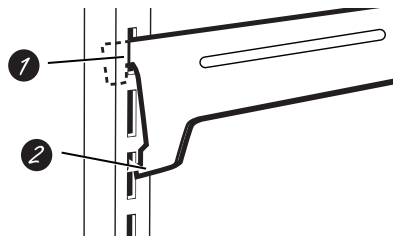

Spillproof Shelves

Spillproof shelves have special edges to help prevent spills from dripping to lower shelves.

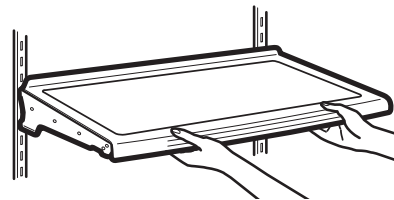

Quick Space Shelf

This shelf splits in half and slides under itself for storage of tall items on the shelf below.

This shelf can be removed and replaced or relocated (just like spillproof shelves).

NOTE: The back half of the Quick Space Shelf is not adjustable.

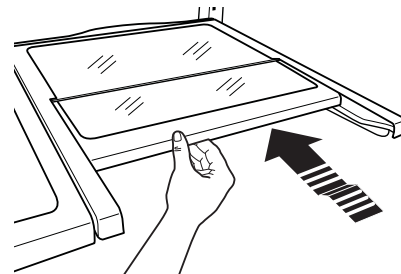

Refrigerator Storage Options

Door Bins

Fixed bins can easily be carried from refrigerator to work area.

To remove: Lift bin straight up, then pull out. The door bins are not interchangeable, note the location upon removal and replace the bin in its proper location.

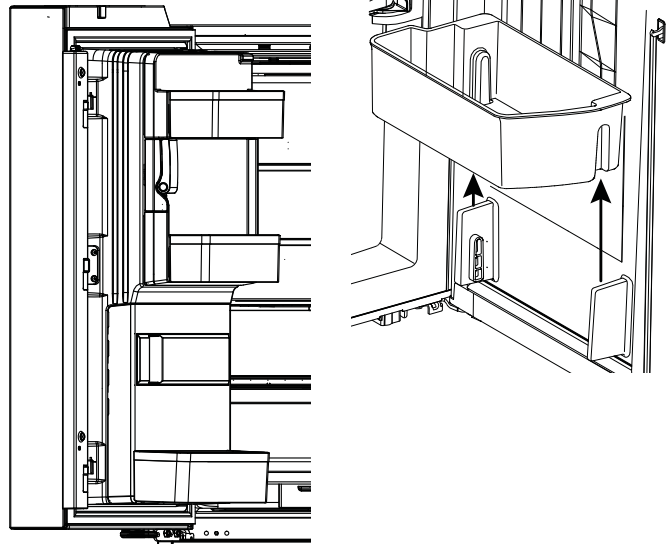

Climate Zone Bins

Keep fruits and vegetables organized in separate compartments for easy access.

Excess water that may accumulate in the bottom of the drawers or under the drawers should be wiped dry.

Vented bin for storing fruits and vegetables

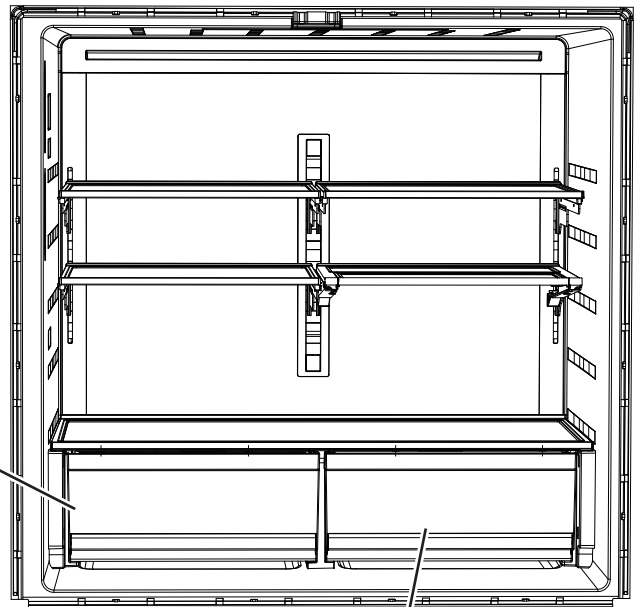

Sealed HCS bin prolongs produce preservation by maintaining humidity in the bin.

Refrigerator Storage Options

CONVERTIBLE DRAWER - Model CVE Only

How To Adjust Drawer Dividers

Grasp divider at the top and slide to the left or right.

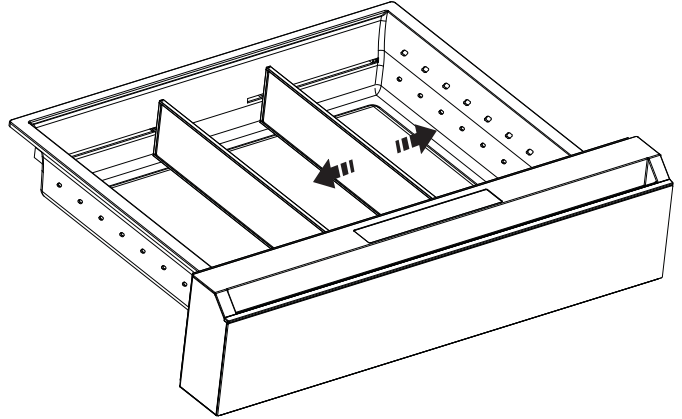

How to Remove and Replace Drawer

To remove:

1. Pull the drawer out to the stop position.
2. Remove the convertible drawer basket by lifting while rotating the basket upward

To replace:

1. Place drawer back in first and rotate drawer front down to seat on slide.
2. Push the drawer in to closed position.
Convertible drawer basket will be loose if re-installed backwards. Look for "FRONT" emboss to help with re-installation.

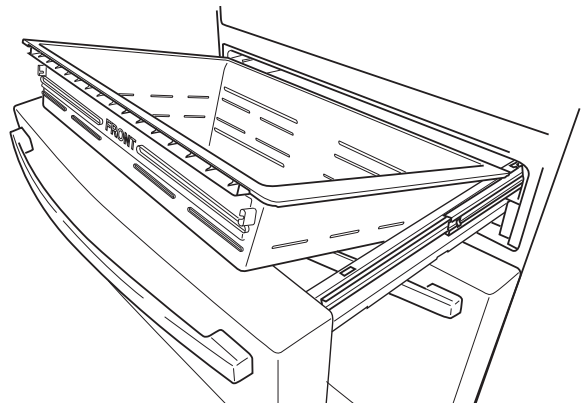

Refrigerator Storage Options

BASKETS, DRAWERS, AND BINS - Model CVE Only

Freezer Basket and Drawer

- ⑦ Basket.
- ② Pizza tray
- ③ Drawer

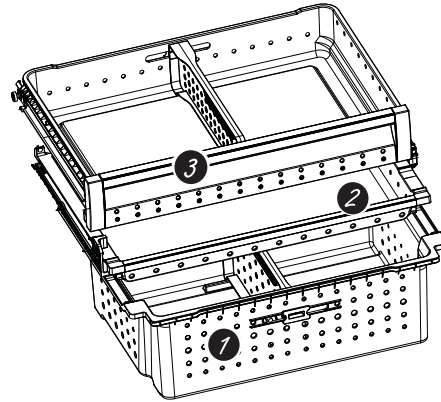

Tilt-Out Bin in the Freezer

To remove:

Press the tab on the right side bracket to remove the freezer drawer bin.

To replace:

Slide bin into location until it locks into place.

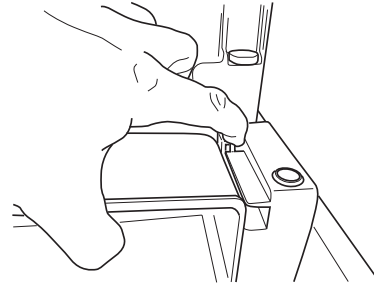

Basket Removal

To remove:

1. Push the top freezer drawer basket all the way inside the freezer compartment. Top drawer is NOT removeable.
2. Pull the pizza tray all the way out and lift up until the pizza tray is free to remove.
3. Press the tab on the right side bracket to remove the freezer door bin.
4. Lift the bottom freezer drawer basket slightly back, then up and out of the drawer.

To replace:

1. Place drawer back in first and rotate drawer front down to seat on slide.

Bottom freezer drawer basket must be in place before installing the pizza drawer.

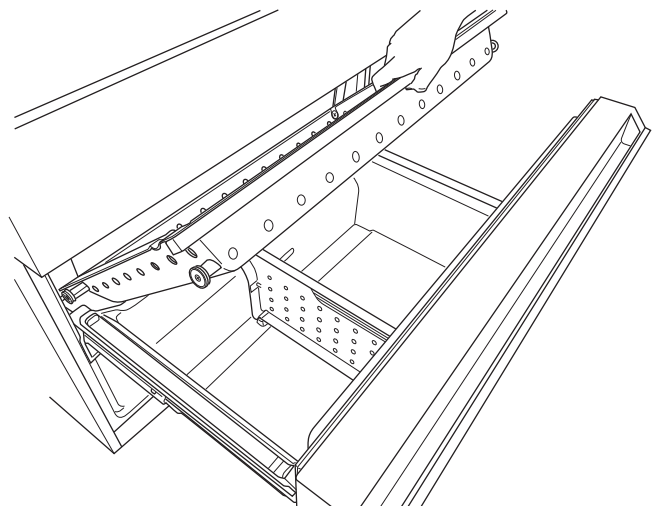

Refrigerator Storage Options

BASKETS, SHELF, AND BINS - Model CQE Only

Freezer Baskets

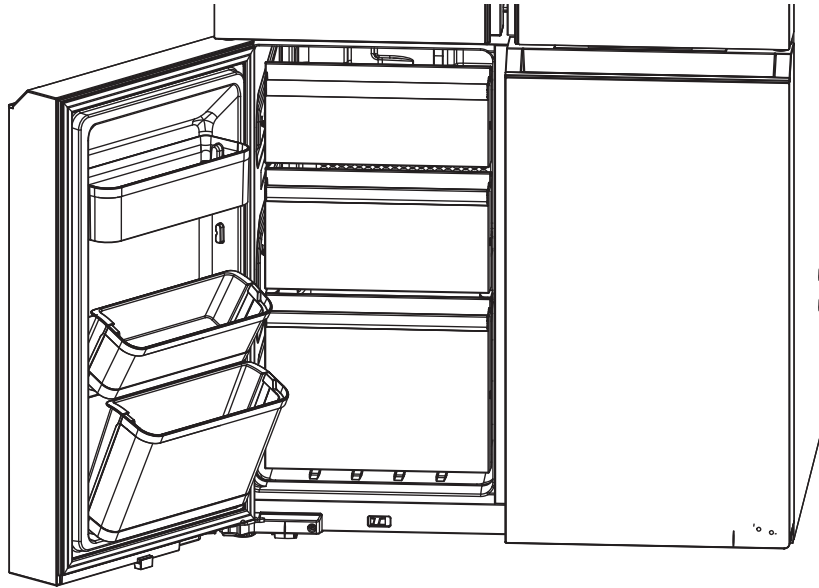

Select Zone Baskets, Shelf, and Wine Rack

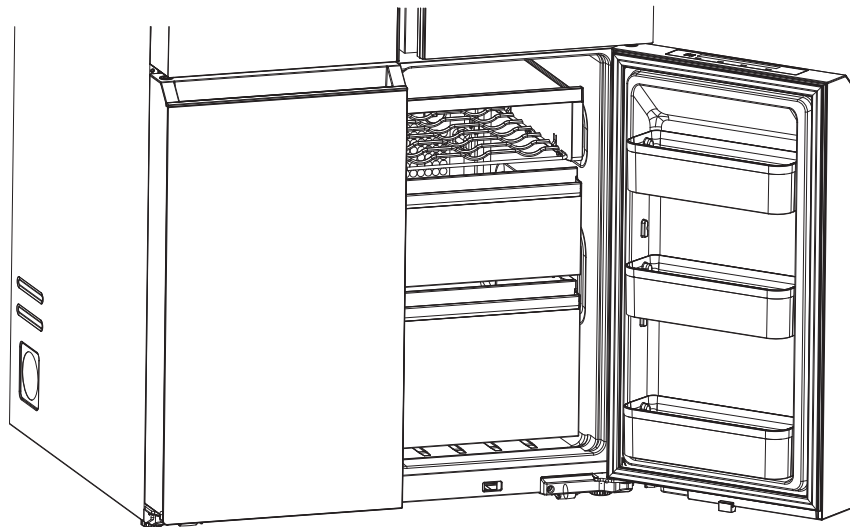

Basket or Shelf Removal

To remove:

1. Pull basket or shelf out all the way.
2. Slightly lift front of basket or shelf and pull out.

To replace:

1. Reverse the removal steps.

Automatic Icemaker

A newly installed refrigerator may take 12 to 24 hours to begin making ice.

⚠ WARNING Connect to potable water supply only.

A cold water supply is required for automatic icemaker operation. The water pressure must be between 40 and 120 psi (275-827 kilopascals).

Automatic Icemaker

The icemaker will produce seven cubes per cycle approximately 100–130 cubes in a 24-hour period, depending on freezer compartment temperature, room temperature, number of door openings and other use conditions.

The icemaker will fill with water when it cools to 15°F (-10°C). A newly installed refrigerator may take 12 to 24 hours to begin making ice cubes.

If the refrigerator is operated before the water line connection is made to the unit or if the water supply to an operating refrigerator is turned off, make sure that the icemaker is turned off. Once the water has been connected to the refrigerator, the icemaker may be turned on using the controls.

You may hear a buzzing sound each time the icemaker fills with water.

To fill the bucket to maximum capacity after installation, dispense 3-4 cubes at 12 hours and 18 hours. Allow 1-2 days for the bucket to completely fill with ice.

Throw away the first few batches of ice to allow the water line to clear.

Be sure nothing interferes with the sweep of the feeler arm.

When the bin fills to the level of the feeler arm, the icemaker will stop producing ice. It is normal for several cubes to be joined together.

If ice is not used frequently, old ice cubes will become cloudy, taste stale and shrink.

NOTE: In homes with lower-than-average water pressure, you may hear the icemaker cycle multiple times when making one batch of ice.

⚠ CAUTION To minimize the risk of personal injury, avoid contact with the moving parts of the ejector mechanism, or with the heating element that releases the cubes. Do not place fingers or hands on the automatic ice making mechanism while the refrigerator is plugged in.

To turn the icemaker **ON/OFF**, use the **Settings** button to navigate to the Icemaker selection. w

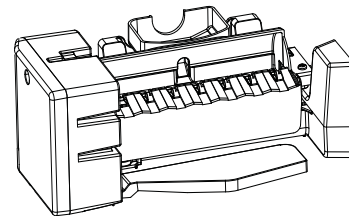

Ice Bucket and Dispenser

- Open the ice box door on inside of the left door.
- Pull up and out on the ice bucket in the left hand door to remove it from the compartment.
- To replace the ice bucket, set it on the guide brackets and push until the ice bucket seats properly.

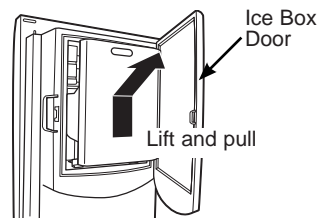

Care and Cleaning

Cleaning the Outside

FINGERPRINT RESISTANT STAINLESS STEEL*, BLACK STAINLESS, SLATE, DARK SLATE, PAINTED, GLASS - Outside surfaces, door handles, and trim

⚠ DO NOT use Stainless Steel cleaners on the door surfaces. ⚠

IMPORTANT: The use of incorrect products may damage the outer finish of Fingerprint Resistant Stainless and Black Stainless models. Please follow these instructions and use only the appropriate items below to clean your appliance surfaces.

- Clean interior/exterior surfaces with warm water, mild soap or detergent, and a soft or microfiber cloth to avoid damage.
- Wipe the appliance surface dry with a soft clean cloth or microfiber towel to avoid streaking or water spotting.

DO USE	DO NOT USE
Soft, clean cloth or sponge Microfiber cloth	Abrasive cloths, paper towels, scrubbing sponges (with or without soap), scouring or steel wool pads
Mild detergent mixed with warm water	Abrasive powders, liquids, or sprays Window sprays, ammonia, or bleach Citrus or plant oil-based cleaners Acidic or vinegar-based cleaners Oven cleaners Alkaline cleaners Stainless steel cleaners

*Easily wipe away smudges and fingerprints.

STAINLESS STEEL - Outside surfaces, door handles, and trim

NOTE: DO NOT allow stainless steel cleaner to come in contact with any plastic parts such as trim pieces, handle hardware and liners. If unintentional contact of cleaners with plastic parts does occur, clean plastic part with a sponge and mild detergent mixed with warm water.

DO USE	DO NOT USE
Soft, clean cloth or sponge	Abrasive cloths, scrubbing sponges (with or without soap), scouring or steel wool pads
Mild detergent mixed with warm water Approved stainless steel cleaners; For approved stainless steel cleaners, visit cafeappliances.com . Cleaners with oxalic acid such as Bar Keepers Friend Soft Cleanser™ can be used to remove surface rust, tarnish and small blemishes on stainless steel surfaces only.	Abrasive powders or sprays Window Sprays or Ammonia Citrus or plant oil-based cleaners Acidic or vinegar-based cleaners Oven cleaners Cleaners containing acetone (propanone) Any cleaner with WARNING about plastic contact

Cleaning the Inside

To help prevent odors, leave an open box of baking soda in the refrigerator and freezer compartments.

Unplug the refrigerator before cleaning.

If this is not practical, wring excess moisture out of sponge or cloth when cleaning around switches, lights or controls.

Use an appliance wax polish on the inside surface between the doors.

Use warm water and baking soda solution—about a tablespoon (15 ml) of baking soda to a quart (1 liter) of water. This both cleans and neutralizes odors. Rinse and wipe dry.

To clean the inside metal panel*, open the outer door using the Door in Door Latch. Clean the panel with a mild detergent and then wipe dry with a soft cloth. Do not use any stainless steel cleaner on the panel as it may damage the surrounding plastic.

⚠ CAUTION Do not clean glass shelves or covers with warm water when they are cold. Glass shelves and covers may break if exposed to sudden temperature changes or impact such as bumping or dropping. Tempered glass is designed to shatter into many small pieces if it breaks.

Do not wash any plastic refrigerator parts in the dishwasher.

Care and Cleaning

Behind the Refrigerator

Be careful when moving the refrigerator away from the wall. All types of floor coverings can be damaged, particularly cushioned coverings and those with embossed surfaces.

Raise the leveling legs located at the bottom front of the refrigerator.

Pull the refrigerator straight out and return it to position by pushing it straight in. Moving the refrigerator in a side direction may result in damage to the floor covering or refrigerator.

Lower the leveling legs until they touch the floor.

⚠ WARNING  **ELECTRICAL SHOCK HAZARD**

When pushing the refrigerator back, make sure you don't roll over the power cord or water supply line.

Preparing for Vacation

For long vacations or absences, remove food and unplug the refrigerator. Clean the interior with a baking soda solution of one tablespoon (15 ml) of baking soda to one quart (1 liter) of water. Leave the doors open.

If the temperature can drop below freezing, have a qualified service technician drain the water supply system to prevent serious property damage due to flooding.

1. Turn refrigerator off (see CONTROLS, page 9) or unplug the refrigerator.

2. Empty ice bucket
3. Turn water supply off

If you cut the water supply off, turn off the icemaker.

Upon returning from vacation:

1. Replace the water filter.
 2. Run 2 gallons (7.57 liters) of water through the cold water dispenser (about 5 minutes) to flush the system.
-

Preparing to Move

Secure all loose items such as shelves and drawers by taping them securely in place to prevent damage.

When using a hand truck to move the refrigerator, do not rest the front or back of the refrigerator against the hand truck. This could damage the refrigerator.

Handle only from the sides of the refrigerator.

Be sure the refrigerator stays in an upright position during moving.

Replacing the Lights

Refrigerator Lights (LEDs)

Appearance may vary by model.

There is LED lighting in the refrigerator compartment, the bottom of the left-hand refrigerator door, and the bottom of the convertible drawer.

An authorized technician will need to replace the LED light.

If this assembly needs to be replaced, visit cafeappliances.com/service to place a service call. In Canada, visit cafeappliances.ca/service.

Installation Instructions

Refrigerator

Questions? Visit our Website at: cafeappliances.com
 In Canada, visit cafeappliances.ca

BEFORE YOU BEGIN

Read these instructions completely and carefully.

⚠ WARNING  **Tip Over Hazard.**

Built-in style models are top heavy, especially with any doors open. These models must be secured with the anti-tip floor bracket to prevent tipping forward, which could result in death or serious injury. Read and follow the entire installation instructions for installing the anti-tip floor bracket packed with your refrigerator.

- **IMPORTANT** — Observe all governing codes and ordinances. Save these instructions for local inspector's use.
- **Note to Installer** – Be sure to leave these instructions with the Consumer.
- **Note to Consumer** – Keep these instructions for future reference.
- **Skill level** – Installation of this appliance requires basic mechanical skills.
- **Completion time** – Refrigerator Installation can vary
 Water Line Installation 30 minutes
- Proper installation is the responsibility of the installer.
- Product failure due to improper installation is not covered under the Warranty.

PREPARATION

MOVING THE REFRIGERATOR INDOORS

If the refrigerator will not fit through a doorway, the refrigerator doors and freezer drawer can be removed.

- To remove the refrigerator doors, see the Installing the Refrigerator section.
- To remove the freezer drawer, see the Removing the Freezer Drawer section.

WATER SUPPLY TO THE ICEMAKER AND DISPENSER

If the refrigerator has an icemaker, it will have to be connected to a cold water line. A GE Appliances water supply kit (containing tubing, shutoff valve, fittings and instructions) is available at extra cost from your dealer, by visiting our website at cafeappliances.com/parts (in Canada at cafeappliances.ca/parts).

TOOLS YOU MAY NEED



Adjustable Wrench

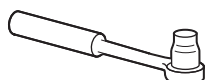

3/8", 5/16" Socket Ratchet/Driver



1/8", 3/32", 3/16", 1/4" & 5/32" Allen Wrenches

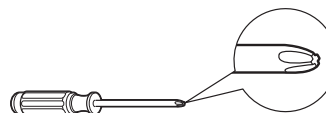

Phillips-Head Screwdriver

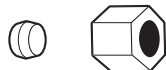

1/4" Outer Diameter Compression Nut and Ferrule (sleeve)



Pencil

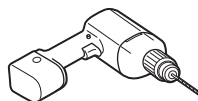

1/8" Drill Bit and Electric or Hand Drill



1/4" Nut Driver

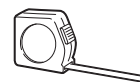

Tape Measure



Pliers



Flat-Head Screwdriver

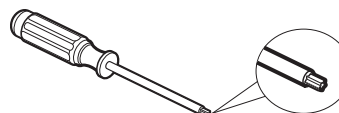

Torx T20, T25



Level

Installation Instructions

DIMENSIONS - CVE Models

NOTE: It is recommended that the floor be protected with a plastic covering throughout the installation process.

NOTE: Not recommended for installation on carpeted flooring.

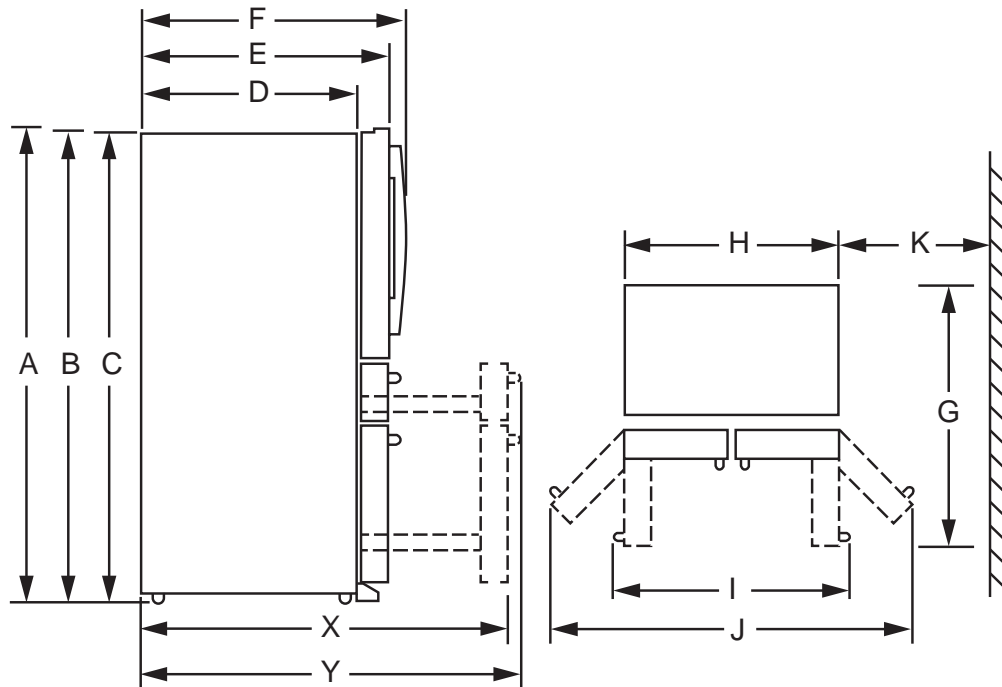

	Cafe Pro	Cafe Glass
Overall Height to Top of the Door (A)	70" (1775 mm)	70" (1775 mm)
Height to Top of Hinge Cover (B)	69-13/16" (1772 mm)	69-13/16" (1772 mm)
Height to Top of Case (C)	68-5/8" (1742 mm)	68-5/8" (1742 mm)
Case Depth without Door (D)	29-3/4" (755 mm)	29-3/4" (755 mm)
Case Depth with Door, less Door Handle (E)	34-9/16" (878 mm)	34-3/8" (872 mm)
Case Depth with Door and Handle (F)	37-1/8" (943mm)	34-3/8" (872 mm)
Depth with Refrigerator Door Open 90° (G)	48-11/16" (1236 mm)	48-11/16" (1236 mm)
Width (H)	35-3/4" (908 mm)	35-3/4" (908 mm)
Width with Door Open 90°, with Handle (I)	45-1/2" (1156 mm)	39-9/16" (1005 mm)
Width with Doors Fully Open (J)	64-1/2" (1638 mm)	60-1/8" (1527 mm)
Min. Distance Between Case and Wall to Allow Doors to Fully Open (K)	13-3/4" (350 mm)	13" (330 mm)
Depth with Freezer Door Completely Open, without Handle (X)	53-15/16" (1369 mm)	53-5/8" (1362 mm)
Depth with Freezer Door Completely Open, with Handle (Y)	56-3/8" (1433 mm)	53-5/8" (1362 mm)

Installation Instructions

DIMENSIONS - CQE Models

NOTE: It is recommended that the floor be protected with a plastic covering throughout the installation process.

NOTE: Not recommended for installation on carpeted flooring.

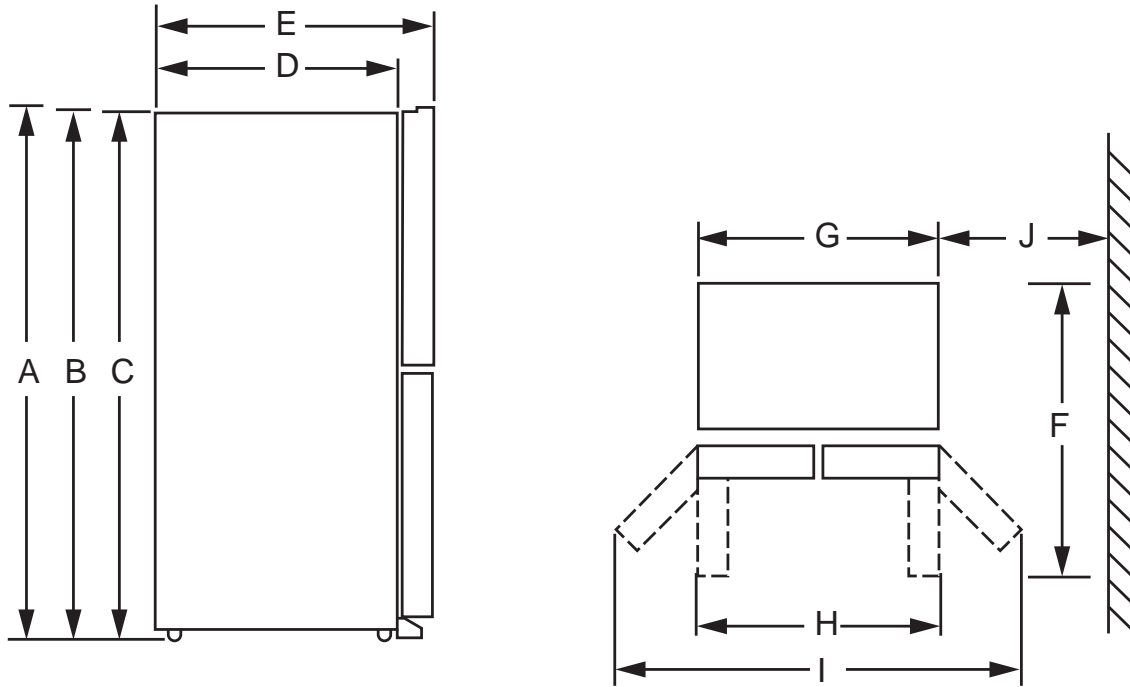

Overall Height to Top of the Door (A)	70" (1775 mm)
Height to Top of Hinge Cover (B)	69-13/16" (1772 mm)
Height to Top of Case (C)	68-5/8" (1742 mm)
Case Depth without Door (D)	29-3/4" (755 mm)
Case Depth with Door (E)	34-3/8" (872 mm)
Depth with Refrigerator Door Open 90° (F)	48-11/16" (1236 mm)
Width (G)	35-3/4" (908 mm)
Width with Door Open 90° (H)	39-9/16" (1005 mm)
Width with Doors Fully Open (I)	60-1/8" (1527 mm)
Min. Distance Between Case and Wall to Allow Doors to Fully Open (J)	13" (330 mm)

Doors must be fully open to get full access to the Freezer and Temp Select Zone drawers.

Installation Instructions

MOVING THE REFRIGERATOR

- Using the chart below determine if the width of your passageway can accommodate the depth of the refrigerator. Ensure you have clearance to prevent damage to the refrigerator before safely moving it to the final location.
- If passageways are large enough to accommodate the refrigerator without removing the handles skip to Step 6. Leave tape, film and all packaging on doors until the refrigerator is in the final location.
- **NOTE: Use a padded hand truck or moving straps to move this refrigerator. Place the refrigerator on the hand truck with a side against the truck. We strongly recommend that two people move and complete this installation.**

If your opening is less than the following dimensions, remove door parts in order until dimension is less than the opening.		
	CVE28DM	CQE
Fully Assembled	37-1/8" (943 mm)	34-7/8" (872 mm)
Remove Handles	34-9/16" (878 mm)	
Remove Doors	32-1/4" (819 mm)	32-1/4" (819 mm)
Remove Center Hinge	29-3/4" (755 mm)	29-3/4" (755 mm)

Installation Instructions

INSTALLING THE REFRIGERATOR

REFRIGERATOR LOCATION

- Do not install the refrigerator where the temperature will go below 60°F (16°C) because it will not run often enough to maintain proper temperatures.
- Do not install the refrigerator where the temperature will go above 100°F (37°C) because it will not perform properly.
- Do not install the refrigerator in a location exposed to water (rain, etc.) or direct sunlight.
- Install it on a floor strong enough to support it fully loaded.

CLEARANCES

Allow the following clearances for ease of installation, proper air circulation and plumbing and electrical connections.

Sides	1/8" (3 mm)	
Top	1" (25 mm)	Cabinet/Hinge Cover
Back	2" (50 mm)	

REMOVING THE REFRIGERATOR DOORS

- **IMPORTANT NOTE:** This refrigerator is 37-1/8" (943 mm) deep (refer to chart on previous page). Doors and passageways leading to the installation location must be at least 37-1/8" (943 mm) wide in order to leave the doors and handles attached to the refrigerator while transporting it into the installation location. If passageways are less than 37-1/8" (943 mm), the refrigerator doors and handles can easily be scratched and damaged. The top cap and doors can be removed to allow the refrigerator to be safely moved indoors. If passageways are less than 34-9/16" (878 mm), start with Step 1.
- If it is not necessary to remove doors, skip to Step 11. Leave tape and all packaging on doors until the refrigerator is in the final location.
- **NOTE:** Use a padded hand truck to move this refrigerator. Place the refrigerator on the hand truck with a side against the truck. We strongly recommend that **TWO PEOPLE** move and complete this installation.

1 REMOVE THE REFRIGERATOR AND FREEZER DOOR HANDLES (if necessary)

Handle design varies; however installation is the same.

1. Tighten/loosen the handle to/from the door by turning set screw with 1/8" Allen wrench. Leave film on door until installation is finished.
2. If handle mounting fasteners need to be tightened or removed, use a 3/16" Allen wrench.

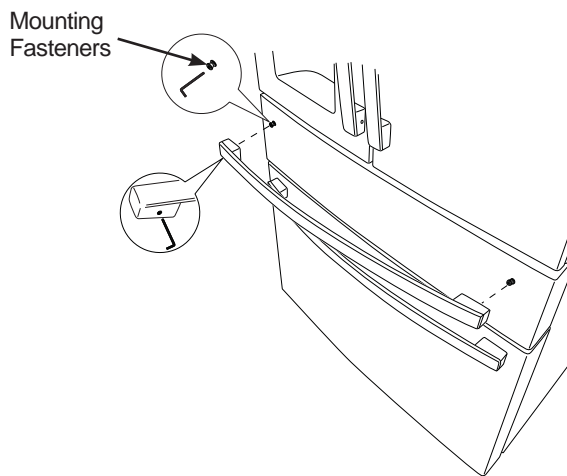
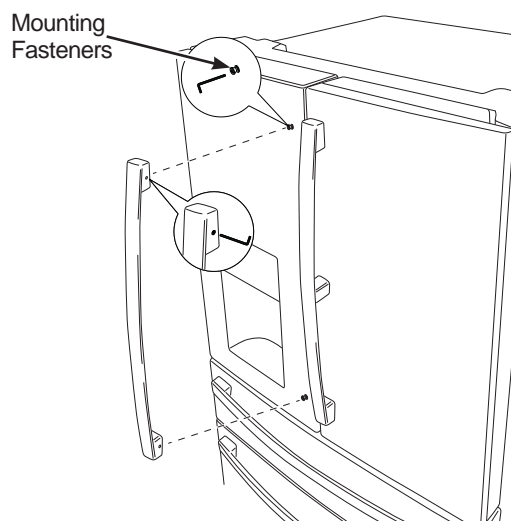

Installation Instructions

INSTALLING THE REFRIGERATOR (Cont.)

2 REMOVE LEFT-HAND DOOR

⚠ WARNING Follow all steps for removing and reinstalling the door. Failure to follow these instructions, leaving off parts, or overtightening screws, can lead to the door falling off and result in injury and property damage.

1. Loosen the icemaker water supply tube.

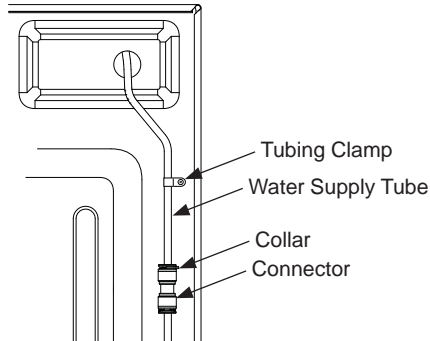

- Loosen and remove the tubing clamp which holds the water supply tube to the back of the refrigerator.
 - Remove the black collar from water supply tube connector at the top right back of the refrigerator.
 - Press the white flange down and separate the water supply line from the connector.
2. Remove the left hinge cover by removing 2 hinge cover screws with a Phillips head screwdriver and lifting from the left side. Disconnect electrical connectors and pull the water supply tube through the case.

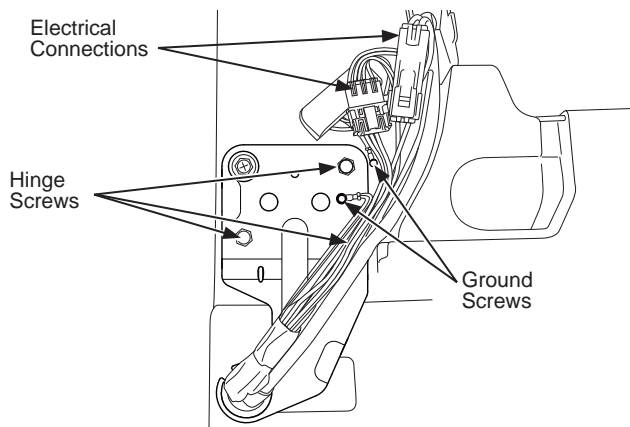

3. Securely tape the door shut with masking tape or have a second person support the door.
4. Remove screws holding hinge with a 5/16" socket. Lift hinge from refrigerator and door.

2 REMOVE LEFT-HAND DOOR (cont.)

For proper installation later, please follow these next steps carefully:

- Remove the tape keeping the door as straight as possible, then lift up to remove.

⚠ CAUTION Lifting Hazard.

A single person lift could cause injury. Gain assistance when handling, moving, or lifting refrigerator doors.

3 REMOVE RIGHT-HAND DOOR

- Remove right hinge cover.
- Securely tape the door shut with masking tape or have a second person support the door.
- Remove screws holding hinge with a 5/16" socket. Lift hinge from refrigerator and door.

For proper installation later, please follow these next steps carefully:

- Remove the tape keeping the door as straight as possible, then lift up to remove.

⚠ CAUTION Lifting Hazard.

A single person lift could cause injury. Gain assistance when handling, moving, or lifting refrigerator doors.

To reassemble doors, reverse removal steps.

4 REMOVE CENTER HINGE (if necessary)

Remove screws that secure hinge to the cabinet. Inner screws need a 5/16" socket. Outer screw needs a Phillips #2.

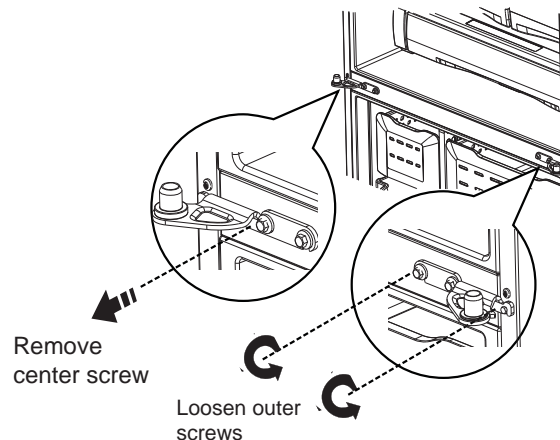

Installation Instructions

INSTALLING THE REFRIGERATOR (Cont.)

5 REMOVING CONVERTIBLE DRAWER (on some models)

1. Remove the convertible drawer basket by lifting while rotating the basket upward.

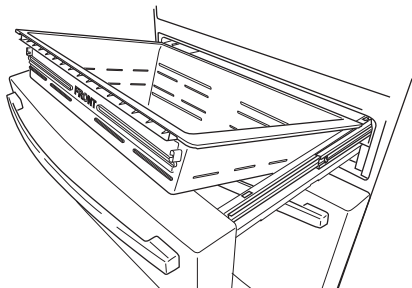

2. Disconnect the wiring control connection for the convertible drawer.
 - Using a flat-head screwdriver, remove cover over electric connectors on inside right of the drawer frame. The cover hooks through the drawer frame toward the inside of the refrigerator.

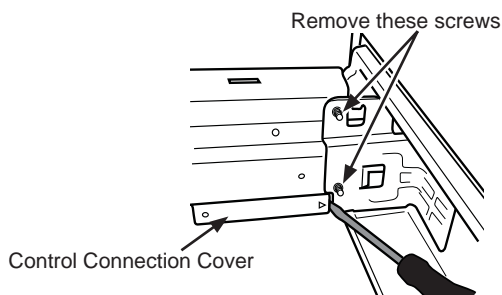

- Press the tab in the center of the connector to separate.

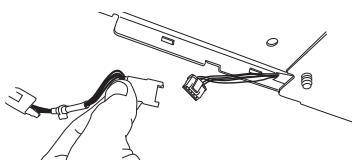

3. Remove 2 screws from each side of the frame with a 5/16" socket.
4. Remove door by lifting off hooks.

6 REMOVE PIZZA TRAY AND LOWER FREEZER BASKET (on some models)

1. Push the top freezer drawer basket all the way inside the freezer compartment.
2. Pull the pizza tray all the way out and lift up until the pizza tray is free to remove.

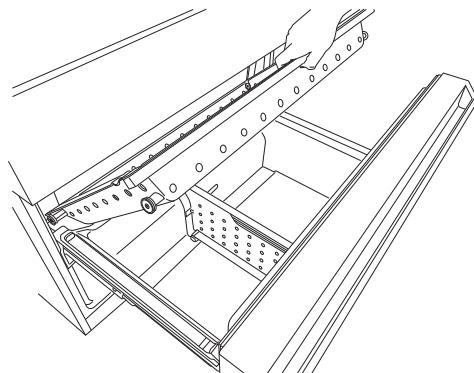

3. Press the tab on the right side bracket to remove the freezer drawer bin.

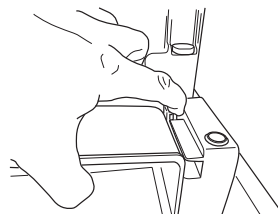

4. Lift the bottom freezer drawer basket slightly back, then up and out of the drawer.
5. Pull the lower basket and slide mechanism to full extension using both hands.
6. Remove the basket resting on the slides.

Installation Instructions

INSTALLING THE REFRIGERATOR (Cont.)

7 REMOVE THE FREEZER DRAWER (on some models)

1. Pull the freezer drawer open to full extension.
2. Remove two screw from each side of the frame with a 5/16" socket.

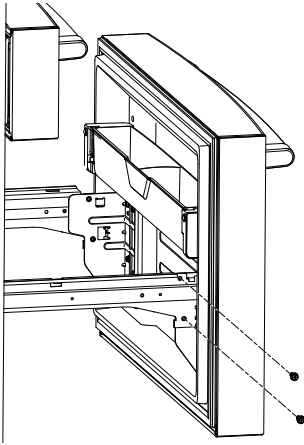

CAUTION Lifting Hazard
Freezer door is heavy Use both hands to secure the door before lifting.

3. Remove the door by lifting off hooks.

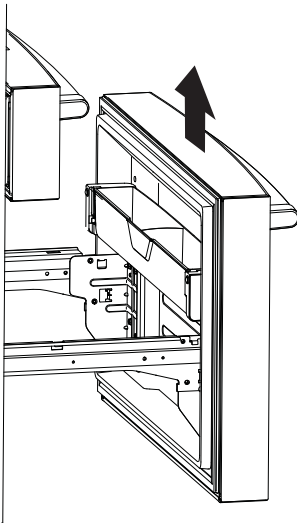

4. Push the bottom basket slides back until the slide mechanism self retracts.

8 REMOVE LOWER LEFT-HAND DOOR (on some models)

WARNING Follow all steps for removing and reinstalling the door. Failure to follow these instructions, leaving off parts, or overtightening screws, can lead to the door falling off and result in injury and property damage.

1. Securely tape the door shut with masking tape or have a second person support the door.
2. Remove the center hinge with a 5/16" socket and Phillips head screwdriver.

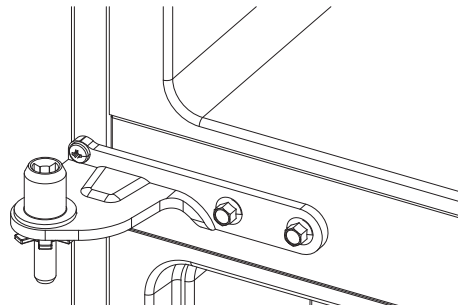

3. Remove the tape keeping the door as straight as possible, then lift up to remove.

CAUTION Lifting Hazard.
A single person lift could cause injury. Gain assistance when handling, moving, or lifting refrigerator doors.

Installation Instructions

INSTALLING THE REFRIGERATOR (Cont.)

9 REMOVE LOWER RIGHT-HAND DOOR (on some models)

1. Open lower right-hand door 90°.
2. Remove lower hinge cover by removing Phillips head screw and unsnapping cover from hinge.

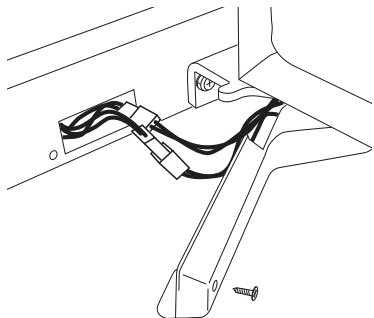

3. Disconnect 2 harnesses.
4. Securely tape the door shut with masking tape or have a second person support the door.
5. Remove the center hinge with a 5/16" socket and Phillips head screwdriver.

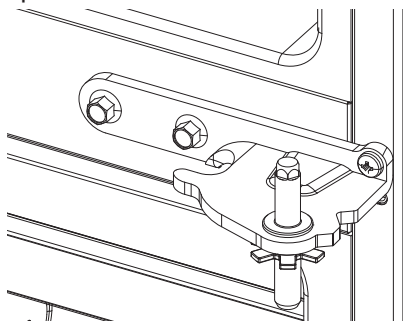

6. Remove the tape keeping the door as straight as possible, then lift up to remove.

CAUTION Lifting Hazard

Freezer door is heavy Use both hands to secure the door before lifting.

1. Pull the lower basket slide mechanism to full extension with both hands.
2. Lift the freezer door and align the hooks with the notches on the slide mechanisms. NOTE: Place one side in first, then align the other side.
3. Replace the attachment screws and torque the screws to 65 in-lb (7.34 N-m).

To reassemble doors, reverse removal steps. Be careful wires pass through bottom right-hand hinge.

10 REMOVE LOWER HINGE (if necessary) (on some models)

Remove screws that secure hinge to the cabinet. Inner screws need a 5/16" socket. Outer screw needs a Phillips #2."

11 RE-INSTALL CONVERTIBLE DRAWER (on some models)

To reassemble doors, reverse removal steps. Convertible drawer basket will be loose if re-installed backwards. Look for "FRONT" emboss to help with re-installation.

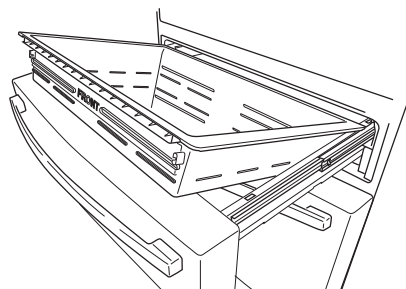

Installation Instructions

INSTALLING THE REFRIGERATOR (Cont.)

12 REPLACE FREEZER DRAWER (on some models)

▲ CAUTION Lifting Hazard

Freezer door is heavy. Use both hands to secure the door before lifting.

1. Pull the lower basket slide mechanism to full extension with both hands.
2. Lift the freezer door and align the hooks with the notches on the slide mechanisms.
NOTE: Place one side in first, then align the other side.

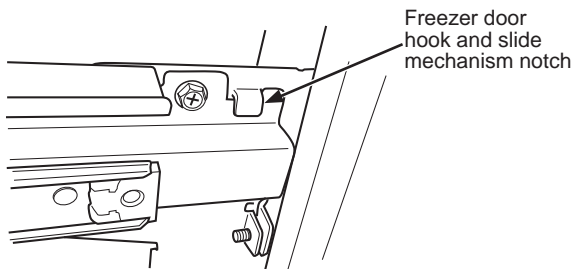

3. Replace the attachment screws and torque the screws to 65 in-lb (7.34 N-m).

13 RE-INSTALL PIZZA TRAY AND LOWER FREEZER BASKET (on some models)

1. Re-install lower freezer basket first, then re-install pizza drawer.

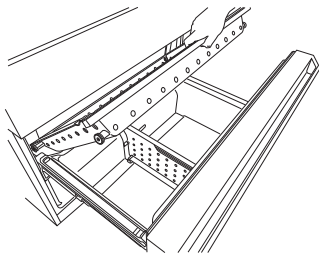

2. Check for smooth operation of baskets.
3. Re-install freezer drawer by placing the drawer wheels onto the top of the track mounted to the side of the freezer walls. The wheels on the freezer drawer should be on top of the bottom basket sides.

14 REINSTALL LOWER LEFT AND RIGHT-HAND DOORS (on some models)

▲ WARNING Follow all steps for removing and reinstalling the door. Failure to follow these instructions, leaving off parts, or overtightening screws, can lead to the door falling off and result in injury and property damage.

▲ CAUTION Lifting Hazard

A single person lift could cause injury. Gain assistance when handling, moving, or lifting refrigerator doors.

1. Reinstall lower hinges first (if necessary) and torque the 5/16" screws to 65 in-lb (7.35 N-m) and small screw to 25 in-lbs (2.82 N-m). Rotating the screw by 1/3 turn after it is flush with mating surface will achieve these torques.
2. With the door at 90° to the front of the case, lower the refrigerator door onto the lower hinge, carefully pulling the harness through the right-hand hinge. Close the door and tape closed.
3. Reinstall the center hinge per step #1 above.
4. Remove the tape.
5. Open the lower right-hand door 90°.
6. Connect the two harnesses.
7. Replace both lower hinge covers (if necessary).

Installation Instructions

INSTALLING THE REFRIGERATOR (Cont.)

15 REINSTALLING THE UPPER LEFT AND RIGHT-HAND DOORS

⚠ WARNING Follow all steps for removing and reinstalling the door. Failure to follow these instructions, leaving off parts, or overtightening screws, can lead to the door falling off and result in injury and property damage.

⚠ CAUTION **Lifting Hazard**

A single person lift could cause injury. Gain assistance when handling, moving, or lifting refrigerator doors.

1. Reinstall center hinge first and torque the 1/4" screw to 65 in-lbs (7.34 N-m) and small screw to 25 in-lbs (2.82 N-m). Rotating the screw by 1/3 turn after it is flush with mating surface will achieve these torques.

2. Lower the refrigerator door onto the center hinge.

3. **Securely tape the door shut with masking tape or have a second person support the door.**

4. Reinstallation is the reverse of the removal instructions.

5. Be sure to reinstall the ground wire and strain relief to the top hinge.

6. Reinstall hinge cover. **NOTE:** Ensure wires are not pinched or under screw bosses before tightening screws.

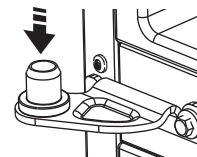

16 CONNECTING REFRIGERATOR TO THE HOUSE WATER LINE

A cold water supply is required for automatic icemaker operation. If there is not a cold water supply, you will need to provide one. See Installing the Water Line section.

NOTES:

- Before making the connection to the refrigerator, be sure the refrigerator power cord is not plugged into the wall outlet.
- If your refrigerator does not have a water filter, we recommend installing one if your water supply has sand or particles that could clog the screen of the refrigerator's water valve. Install it in the water line near the refrigerator. If using SmartConnect™ Refrigerator Tubing Kit, you will need an additional tube (WX08X10002) to connect the filter. Do not cut plastic tube to install filter.
- Before connecting the water line to the house, purge the house line for at least 2 minutes.

1. If you are using copper tubing, place a compression nut and ferrule (sleeve) onto the end of the tubing coming from the house cold water supply.
If you are using the SmartConnect™ tubing, the nuts are already assembled to the tubing.

2. If you are using copper tubing, insert the end of the tubing into the refrigerator connection, at the back of the refrigerator, as far as possible. While holding the tubing, tighten the fitting.

If you are using SmartConnect™ tubing, insert the molded end of the tubing into the refrigerator connection, at the back of the refrigerator, and tighten the compression nut until it is hand tight. Then tighten one additional turn with a wrench. Over tightening may cause leaks.

3. Fasten the tubing into the clamp provided to hold it in position. You may need to pry open the clamp.

⚠ WARNING Connect to potable water supply only. A cold water supply is required for automatic icemaker operation. The water pressure must be between 40 and 120 psi (275-827 kilopascals)

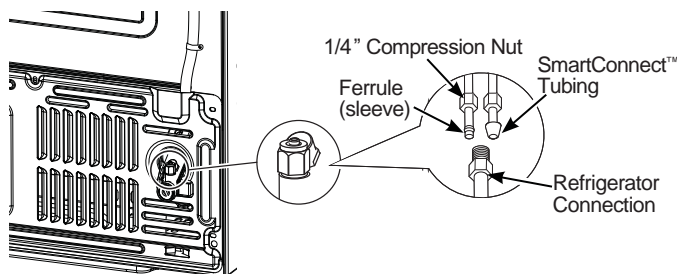

⚠ WARNING **Electrical Shock Hazard.** Attach tubing clamp using existing hole only. DO NOT drill into the refrigerator.

Installation Instructions

INSTALLING THE REFRIGERATOR (Cont.)

17 TURN ON THE WATER SUPPLY

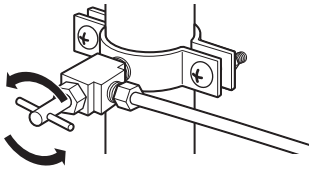

Turn the water on at the shutoff valve (house water supply) and check for any leaks.

18 PLUG IN THE REFRIGERATOR

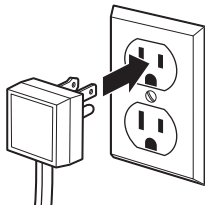

See the grounding information attached to the power cord.

19 LEVEL THE REFRIGERATOR

The leveling legs have 2 purposes:

1. Leveling legs adjust so the refrigerator is firmly positioned on the floor and does not wobble.
2. Leveling legs serve as a stabilizing brake to hold the refrigerator securely in position during operation and cleaning. The leveling legs also prevent the refrigerator from tipping.

- Turn the leveling legs clockwise to raise the refrigerator, counterclockwise to lower it.

NOTICE: To avoid possible property damage, the leveling legs must be firmly touching the floor.

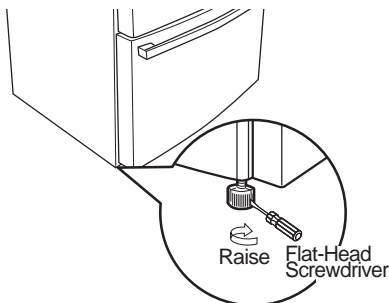

20 LEVEL THE REFRIGERATOR DOORS

Remember a level refrigerator is necessary for getting the doors perfectly even. If you need help, review the previous section on leveling the refrigerator.

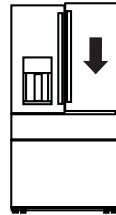

When the left door is lower than the right door.

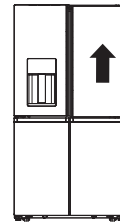

When the left door is higher than the right door.

For 2 drawer models:

1. Access the hinge screws by opening the convertible drawer.
2. Insert 1/4" Allen wrench into the shaft of the center hinge.
3. Adjust the height by turning clockwise or counterclockwise. When you turn counterclockwise, the door will move up.

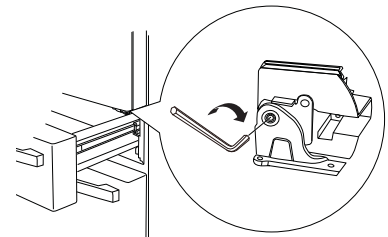
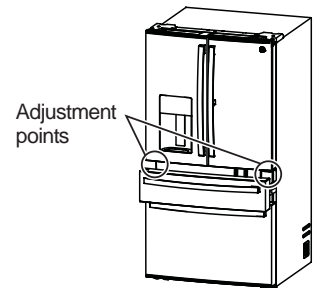

For 4 door models:

Using a 1/4" open end wrench or flat-head screwdriver, turn the slotted wheel to adjust doors up or down.

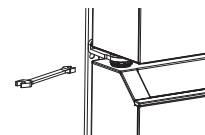
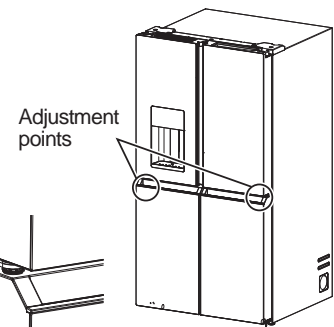

To adjust the height of the lower doors:

- Remove the left-hand and right-hand hinge covers with a Phillips head screwdriver, then use a 9/16" open end wrench to adjust the doors up or down.

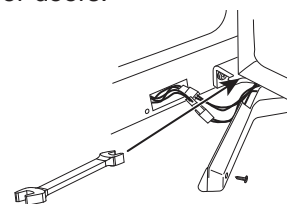

Installation Instructions

INSTALLING THE REFRIGERATOR (Cont.)

CVE Models

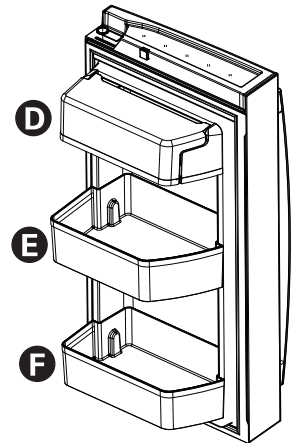
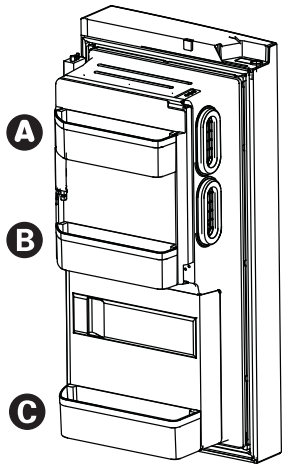
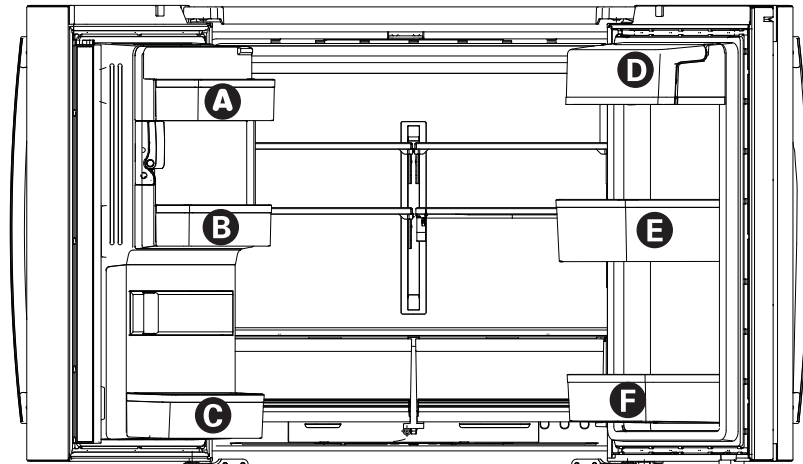

To place bins into doors:

- 1 Match your bin with the letter shown. Position the bins over the bin locator and push forward until inserted fully.
- 2 Push bin down until locked into position.

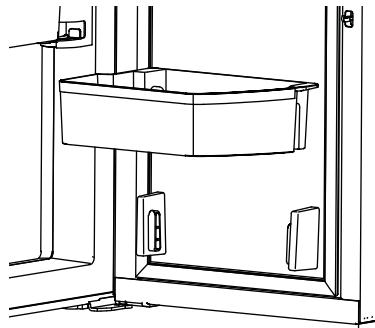

Installation Instructions

INSTALLING THE REFRIGERATOR (Cont.)

CQE Models

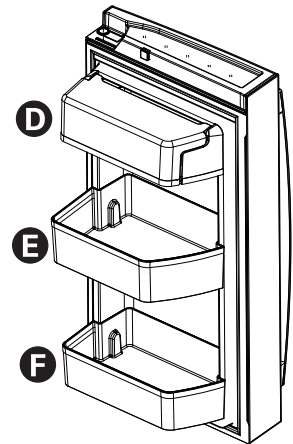
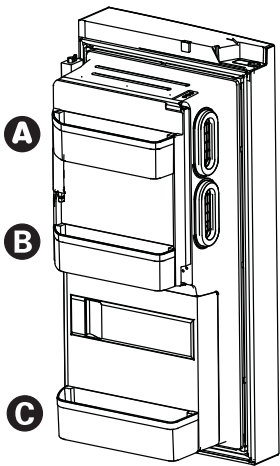
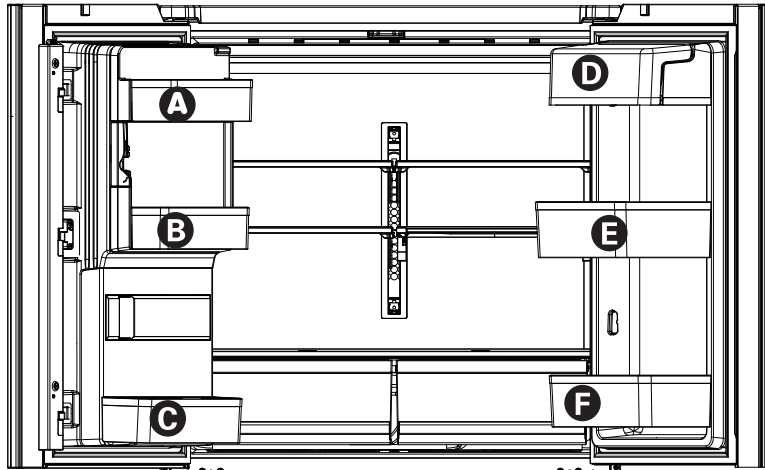

To place bins into doors:

- 1 Match your bin with the letter shown. Position the bins over the bin locator and push forward until inserted fully.
- 2 Push bin down until locked into position.

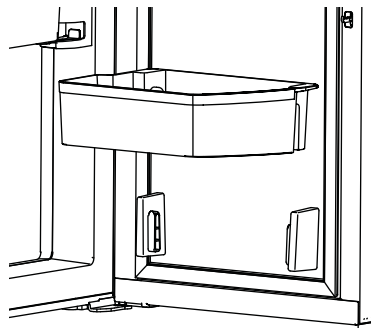

Installation Instructions

INSTALLING THE WATER LINE

BEFORE YOU BEGIN

Recommended copper water supply kits are WX8X2, WX8X3 or WX8X4, depending on the amount of tubing you need. Approved plastic water supply lines are SmartConnect™ Refrigerator Tubing (WX08X10006, WX08X10015 and WX08X10025).

When connecting your refrigerator to a GE Appliances Reverse Osmosis Water System, the only approved installation is with a GE Appliances RVKit. For other reverse osmosis water systems, follow the manufacturer's recommendations.

If the water supply to the refrigerator is from a Reverse Osmosis (RO) Water Filtration System AND the refrigerator also has a water filter, use the refrigerator's filter bypass plug. Using the refrigerator's water filtration cartridge in conjunction with the RO water filter can result in hollow ice cubes. Some models do not come equipped with the filter bypass plug. To obtain a free bypass plug, visit cafeappliances.com. In Canada, visit cafeappliances.ca.

This water line installation is not warranted by the refrigerator or icemaker manufacturer. Follow these instructions carefully to minimize the risk of expensive water damage.

Water hammer (water banging in the pipes) in house plumbing can cause damage to refrigerator parts and lead to water leakage or flooding. Call a qualified plumber to correct water hammer before installing the water supply line to the refrigerator.

To prevent burns and product damage, do not hook up the water line to the hot water line.

If the refrigerator is operated before the water connection is made to the icemaker, see **Controls** section on page 9 to turn icemaker off.

Do not install the icemaker tubing in areas where temperatures fall below freezing.

When using any electrical device (such as a power drill) during installation, be sure the device is double insulated or grounded in a manner to prevent the hazard of electric shock, or is battery powered.

All installations must be in accordance with local plumbing code requirements.

WHAT YOU WILL NEED

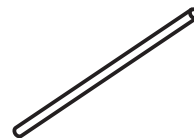

- Copper or SmartConnect™ Refrigerator Tubing kit, 1/4" outer diameter to connect the refrigerator to the water supply. If using copper, be sure both ends of the tubing are cut square.

To determine how much tubing you need: measure the distance from the water valve on the back of the refrigerator to the water supply pipe. Be sure there is sufficient extra tubing to allow the refrigerator to move out from the wall after installation.

SmartConnect™ Refrigerator Tubing Kits are available in the following lengths:

- 8' (2.4 m) – WX08X10006
- 15' (4.6 m) – WX08X10015
- 25' (7.6 m) – WX08X10025

⚠ WARNING

Connect to potable water supply only.

A cold water supply is required for automatic icemaker operation. The water pressure must be between 40 and 120 psi (275-827 kilopascals)

Installation Instructions

INSTALLING THE WATER LINE (Cont.)

WHAT YOU WILL NEED (Cont.)

NOTE: The only Café approved plastic tubing is that supplied in SmartConnect™ Refrigerator Tubing kits. Do not use any other plastic water supply line because the line is under pressure at all times. Certain types of plastic will crack or rupture with age and cause water damage to your home.

- A GE Appliances water supply kit (containing tubing, shutoff valve and fittings listed below) is available at extra cost from your dealer or by visiting cafeappliances.com (in Canada, cafeappliances.ca).
- A cold water supply. The water pressure must be between 20 and 120 p.s.i. (1.4–8.1 bar).

- Power drill.
- 1/2" or adjustable wrench.
- Straight and Phillips blade screwdriver.

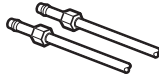
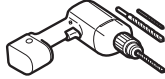

- Two 1/4" outer diameter compression nuts and 2 ferrules (sleeves)—to connect the copper tubing to the shutoff valve and the refrigerator water valve.
OR
- If you are using a SmartConnect™ Refrigerator Tubing kit, the necessary fittings are preassembled to the tubing.

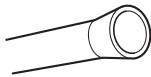

- If your existing copper water line has a flared fitting at the end, you will need an adapter (available at plumbing supply stores) to connect the water line to the refrigerator OR you can cut off the flared fitting with a tube cutter and then use a compression fitting. Do not cut formed end from SmartConnect™ Refrigerator tubing.

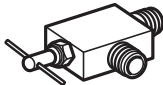

- Shutoff valve to connect to the cold water line. The shutoff valve should have a water inlet with a minimum inside diameter of 5/32" at the point of connection to the COLD WATER LINE. Saddle-type shutoff valves are included in many water supply kits. Before purchasing, make sure a saddle-type valve complies with your local plumbing codes.

Install the shutoff valve on the nearest frequently used drinking water line.

1 SHUT OFF THE MAIN WATER SUPPLY

Turn on the nearest faucet long enough to clear the line of water.

2 CHOOSE THE VALVE LOCATION

Choose a location for the valve that is easily accessible. It is best to connect into the side of a vertical water pipe. When it is necessary to connect into a horizontal water pipe, make the connection to the top or side, rather than at the bottom, to avoid drawing off any sediment from the water pipe.

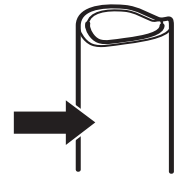

3 DRILL THE HOLE FOR THE VALVE

Drill a 1/4" hole in the water pipe (even if using a self-piercing valve), using a sharp bit. Remove any burrs resulting from drilling the hole in the pipe.

Take care not to allow water to drain into the drill.

Failure to drill a 1/4" hole may result in reduced ice production or smaller cubes.

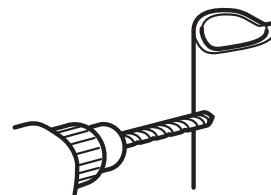

Installation Instructions

INSTALLING THE WATER LINE (Cont.)

4 FASTEN THE SHUTOFF VALVE

1. Fasten the shutoff valve to the cold water pipe with the pipe clamp.

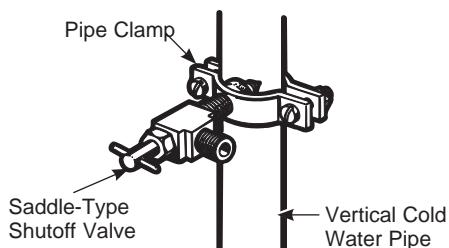

NOTE: Commonwealth of Massachusetts Plumbing Codes 248CMR shall be adhered to. Saddle valves are illegal and use is not permitted in Massachusetts. Consult with your licensed plumber.

5 TIGHTEN THE PIPE CLAMP

Tighten the clamp screws until the sealing washer begins to swell.

NOTE: Do not over tighten or you may crush the tubing.

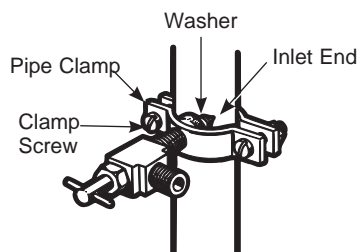

6 ROUTE THE TUBING

Route the tubing between the cold water line and the refrigerator.

Route the tubing through a hole drilled in the wall or floor (behind the refrigerator or adjacent base cabinet) as close to the wall as possible.

7 CONNECT THE TUBING TO THE VALVE

Place the compression nut and ferrule (sleeve) for copper tubing onto the end of the tubing and connect it to the shutoff valve.

Make sure the tubing is fully inserted into the valve. Tighten the compression nut securely.

For plastic tubing from a SmartConnect™ Refrigerator Tubing kit, insert the molded end of the tubing into the shutoff valve and tighten compression nut until it is hand tight, then tighten one additional turn with a wrench. Over tightening may cause leaks.

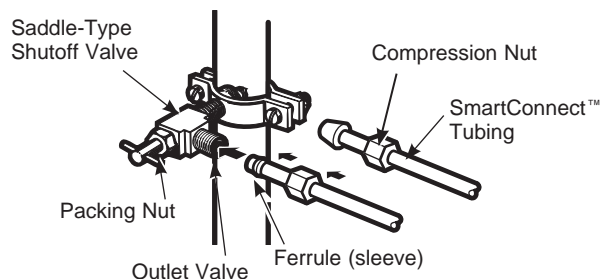

NOTE: Commonwealth of Massachusetts Plumbing Codes 248CMR shall be adhered to. Saddle valves are illegal and use is not permitted in Massachusetts. Consult with your licensed plumber.

8 FLUSH OUT THE TUBING

Turn the main water supply on and flush out the tubing until the water is clear.

Shut the water off at the water valve after about one quart (1 liter), or 2 minutes, of water has been flushed through the tubing.



To complete the installation of the refrigerator, go back to Step 12 in Installing the Refrigerator.

Normal Operating Conditions.

Newer refrigerators sound different from older refrigerators. Modern refrigerators have more features and use newer technology.

Do you hear what I hear? These conditions are normal.

HUMMM...

WHOOSH...

- The new high efficiency compressor may run faster and longer than your old refrigerator and you may hear a high-pitched hum or pulsating sound while it is operating.
- You may hear a whooshing sound when the doors close. This is due to pressure equalizing within the refrigerator.
- After dispensing ice, a motor will close the ice chute to keep warm room air from entering the ice bucket, maintaining ice at a freezing temperature. The hum of the motor closing the ice chute is normal, shortly after dispensing ice.



- You may hear the fans spinning at high speeds. This happens when the refrigerator is first plugged in, when the doors are opened frequently or when a large amount of food is added to the refrigerator or freezer compartments. The fans are helping to maintain the correct temperatures.
- The fans change speeds in order to provide optimal cooling and energy savings.

CLICKS, POPS, CRACKS and SNAPS

- You may hear cracking or popping sounds when the refrigerator is first plugged in. This happens as the refrigerator cools to the correct temperature.
- The compressor may cause a clicking or chirping sound when attempting to restart (this could take up to 5 minutes).
- Expansion and contraction of cooling coils during and after defrost can cause a cracking or popping sound.
- On models with an icemaker, after an ice making cycle, you may hear the ice cubes dropping into the ice bucket.
- After dispensing ice, a motor will close the ice chute to keep warm room air from entering the ice bucket, maintaining ice at a freezing temperature.

WATER SOUNDS



- The flow of refrigerant through the cooling coils may make a gurgling noise like boiling water.
- Water dropping on the defrost heater can cause a sizzling, popping or buzzing sound during the defrost cycle.
- A water dripping noise may occur during the defrost cycle as ice melts from the evaporator and flows into the drain pan.
- Closing the door may cause a gurgling sound due to pressure equalization.

START UP COOLING

It can take up to 24 hours for the refrigerator and freezer temperatures to match the display. During that time refrigerator and freezer door openings should be minimized.

TIPS

- Freezer cools first.
- Refrigerator compartment cools last; it may take several hours after the freezer.
- Turning off icemaker makes both refrigerator and freezer food cool faster.

Troubleshooting Tips... Before you call for service

Save time and money! Review the charts on the following pages first and you may not need to schedule service.

Problem	Possible Causes	What to Do
Not filtering	Filter bypass installed	Install correct water filter
Reset Water Filter Water Filter Expired	Water filter leaking or needs replacing	Replace water filter, or install filter bypass* To reset filter timer, press the Settings (⚙️) button until "Icemaker" is highlighted, then hold down the Water and Ice buttons simultaneously for 3 seconds."
Water filter indicator light is not lit	This is normal. This indicator will turn on to tell you that you need to replace the filter soon.	See Water Filter for more information.
Handle is loose/handle has a gap.	Handle needs adjusting	See Installing the Refrigerator section for detailed instructions.
Refrigerator beeping	The door alarm is beeping	-Turn off or disable with door closed -If door open and alarm is sounding, you can only snooze the alarm
Refrigerator lights off and "SA" shown in display	Unit is in Sabbath mode	Simultaneously hold the Settings (⚙️) button, Water , and Light buttons for three seconds to exit Sabbath mode
Not cooling	The cooling system is off	See Controls.
Water has poor taste/odor	Water dispenser has not been used for a long time	Dispense water, until all water in system is replenished.
Water in glass is warm	Normal when refrigerator is first installed	Wait 24 hours for the refrigerator to completely cool down.
	Water dispenser has not been used for a long time	Dispense water, until all water in system is replenished
	Water system has drained	Allow several hours for replenished supply to chill
Water dispenser does not work	Water supply line turned off or not connected	See Installing the Water Line
	Water filter clogged or filter/bypass plug not installed	Replace filter cartridge or remove filter and install bypass plug*
	Air may be trapped in the water system	Press the dispenser arm for at least 5 minutes.
	Water in reservoir is frozen because the controls are set too cold	Set the refrigerator control to a warmer setting and wait 24 hours. If the water does not dispense after 24 hours, call for service
Water spurting from dispenser	Newly installed filter cartridge	Run water from the dispenser for 5 minutes (about 2 gallons)
No water or ice cube production	Supply line or shutoff valve is clogged	Call a plumber
	Water filter is clogged	Replace filter cartridge or remove filter and install bypass plug*
	Filter cartridge not properly installed	Remove and reinstall filter cartridge, being certain that it locks in place.
	Icemaker is turned off	Check that the icemaker is turned on. See Controls

*Some models do not come equipped with the filter bypass plug. To obtain a free bypass plug, visit cafeappliances.com.

Troubleshooting Tips... Before you call for service

Problem	Possible Causes	What to Do
Water is leaking from dispenser	Air may be present in the water line system, causing water to drip after being dispensed	Dispense water for at least 5 minutes to remove air from system
AUTO FILL under fill/no fill	Not all containers work with AutoFill	Try different container
	Error message	See page 12
		Clean sensor. See page 12
AUTO FILL overfills	Not all containers work with AutoFill	Try different container Use less ice Ensure hands are away from the cup prior to pressing the AutoFill key
Freezer cooling, refrigerator not cooling	Normal, when refrigerator first plugged in or after extended power outage	Wait 24 hours for temperature in both compartments to reach selected temperatures.
Ice dispenser opens after closing freezer drawer	Normal	The ice dispenser door may open after closing freezer door to allow access
My refrigerator door squeaks	Diminished lubricant because of accidental cleaning of the lubricant on the hinge	It is best to order GEA lubricant service part number WR97X166 and apply on the hinge at specified location. It is possible to spray some non-toxic lubricant such as silicone based non-stick cooking spray, petroleum jelly or NSF approved food grade lubricants. IMPORTANT: Do not use WD-40 as it will remove any remaining grease in or around the hinge
	Improper leveling	Make sure the unit is leveled
	If doors were removed and re-assembled during installation process, waterline and/harness under Top Hinge cover may get out of position and rub against door while door swivels.	Remove the Top Hinge cover and make sure the waterline and harness that passes through the hinge pin has been properly seated and does not touch the any of the door parts during rotation. Applying some food grade lubricant around door thimble area will also help.

*Some models do not come equipped with the filter bypass plug. To obtain a free bypass plug, visit cafeappliances.com.

Truth or Myth

SERVICE

Save time and money! Review the charts on the following pages first and you may not need to schedule service.

Truth or Myth

Truth or Myth?	Answer	Explanation
The refrigerator water filter may require replacement, even though the filter indicator has not turned red, or reads "Filter Expired."	TRUE	The water filter indicator will indicate the need to replace the water filter every six months. Water quality varies from city to city; if water flow from the dispenser slows, or ice production decreases, the water filter should be replaced, even though the filter indicator may not indicate the need for replacement.
The automatic ice maker in my refrigerator will produce ice when the refrigerator is plugged in to a power receptacle.	MYTH	The refrigerator must be connected to water, and the ice maker must be turned on. Make sure the ice maker is turned on, only after the water line is connected and water is turned on. The ice maker can be turned on/off from the controls and ensure the ice maker is on, as indicated on the refrigerator control panel. See Automatic Ice Maker section in the full owner's manual available online.
After the refrigerator has been plugged in and connected to water, I will immediately have unlimited chilled water available from the water dispenser.	MYTH	The water dispenser tank located inside the refrigerator stores water for dispensing. The water in this tank requires 24 hours to chill after installation. High usage conditions will not allow time for the water to chill.
After water dispenses, a few drops of water are normal.	TRUE	A few drops of water may fall from the dispenser, after the dispenser paddle has been released. To minimize the drops, remove the glass slowly from the dispenser.
I will never see frost inside the freezer compartment.	MYTH	Frost inside the freezer typically indicates that the door is not properly sealed, or has been left open. If frost is found, clear the frost using a plastic spatula and towel, then check to ensure that no food packages or containers are preventing the freezer door from closing. Check the refrigerator control panel to ensure the door alarm is on.
When the refrigerator is installed, or after replacing the water filter, I must dispense water for five minutes.	TRUE	A newly installed refrigerator or water filter contains air in the water lines. Press the dispenser paddle and dispense cold water for at least 5 minutes to remove air from the water line, and flush the filter.
To fill the ice bucket to the maximum capacity, I should dispense 12 and 18 hours after installation.	TRUE	Dispensing 3-4 cubes 12 hours and 18 hours after installation, allows ice to disperse within the ice bucket, which in turns calls on the ice maker to produce additional ice. Normal ice production = 100 cubes in 24 hours.
I can use the water filter bypass plug to determine if the filter requires replacement.	TRUE	Decrease in flow from the water dispenser, or decreased ice production, may indicate the need to replace the water filter. Install the water filter bypass plug (provided with the refrigerator on some models*), and check flow from the dispenser. If water flow returns to normal with the bypass plug in place, replace the water filter.
The top of the refrigerator doors will always be aligned.	MYTH	Several things can affect the refrigerator door alignment, including the floor the refrigerator is installed on and loading of doors. If the top of the refrigerator doors are not aligned, use a 1/4" allen wrench to adjust the right/left hand door. The adjustment screw is located on the bottom right or left hand side of the door. Refrigerator doors should be open during height adjustment. Open the freezer door to access the screw. See Step 15.
Refrigerator door handles can be easily tightened.	TRUE	If door handles are loose or have a gap, the handle can be adjusted using a 1/8" allen wrench, on set screws located on the ends of the handles.
There may be odor and taste problems with your ice.	TRUE	After starting the ice maker throw away 24 hours of ice production to avoid odor and taste problems.
I can make fine adjustments to the refrigerator doors to align them.	TRUE	If the refrigerator doors are not aligned, use a 1/4" Allen wrench to adjust the right hand door. The adjustment screw is located on the bottom of the right door. Open the freezer door to access. See step 15.

Truth or Myth

SERVICE

Save time and money! Review the charts on the following pages first and you may not need to schedule service.

Truth or Myth

Truth or Myth?	Answer	Explanation
Door handles should always be removed for installation.	MYTH	Check chart on reverse side of this instruction. If the doors must be removed do not remove the handles, or if the refrigerator will fit easily through the passage way opening. Adjust handles that are loose or have a gap, by adjusting 1/8" set screws on either end of handles.
Door removal is always required for installation.	MYTH	Check chart on reverse side of this instruction. Doors should only be removed when necessary to prevent damage from passage way or access to final location.
Refrigerator doors will self-close if left open.	MYTH	Refrigerator doors need to be closed by consumer. A gentle bounce back is a designed feature on some models that gives a positive feedback to the user so that they can initiate and complete the door closing action.
There is an adjustment to rear wheels.	MYTH	Front leveling legs are adjustable and should be used to balance the refrigerator. Leveling legs are used to make initial refrigerator door adjustment.
Check for leaks after all water connections are made.	TRUE	While purging the air from the water system, check all water line connections for leaks. Check the connection to the household water supply at back of refrigerator, and door water line connect.
Any packaging residue can be cleaned off the refrigerator using any cleaner.	MYTH	Do not use wax, polish, bleach, or other products containing chlorine on Stainless Steel panels, door handles and trim. Check this instruction under "Cleaning the Outside" for full details.

*Some models do not come equipped with the filter bypass plug. To obtain a free bypass plug, visit cafeappliances.com.

Café Appliances Refrigerator Limited Warranty

cafeappliances.com

All warranty service is provided by our Factory Service Centers, or an authorized service technician. To schedule service online, visit us at **cafeappliances.com/service**. Please have your serial number and your model number available when scheduling service. In Canada, visit **cafeappliances.ca/service**.

Servicing your refrigerator may require the use of the onboard data port for diagnostics. This gives a Café Factory Service technician the ability to quickly diagnose any issues with your appliance and helps Café improve its products by providing Café with information on your appliance. If you do not want your appliance data to be sent to Café, please advise your technician NOT to submit the data to Café at the time of service.

For the Period of:	Café Will Replace
One Year From the date of the original purchase	Any part of the refrigerator which fails due to a defect in materials or workmanship. During the limited one-year warranty , Café will also provide, free of charge , all labor and related service to replace the defective part.
Thirty Days (Water filter, if included) From the original purchase date of the refrigerator	Any part of the water filter cartridge which fails due to a defect in materials or workmanship. During this limited thirty-day warranty , Café will also provide, free of charge , a replacement water filter cartridge.
Five Years From the date of the purchase	Any part of the sealed refrigerating system (the compressor, condenser, evaporator and all connecting tubing) which fails due to a defect in materials or workmanship. During this limited five-year sealed refrigerating system warranty , Café will also provide, free of charge , all labor and related service to replace the defective part in the sealed refrigerating system.

What Café Will Not Cover:

- Service trips to your home to teach you how to use the product.
- Improper installation, delivery or maintenance.
- Failure of the product if it is abused, misused, or used for other than the intended purpose or used commercially.
- Loss of food due to spoilage.
- Replacement of house fuses or resetting of circuit breakers.
- Damage to finish, such as surface rust, tarnish, or small blemishes not reported within 48 hours of delivery.
- Replacement of the water filter cartridge, if included, due to water pressure that is outside the specified operating range or due to excessive sediment in the water supply.
- Replacement of the light bulbs, if included, or water filter cartridge, if included, other than as noted above.
- Damage to the product caused by accident, fire, floods or acts of God.
- Incidental or consequential damage caused by possible defects with this appliance.
- Product not accessible to provide required service.
- Damage caused by a non-GE Appliances Brand water filter.

EXCLUSION OF IMPLIED WARRANTIES

Your sole and exclusive remedy is product repair as provided in this Limited Warranty. Any implied warranties, including the implied warranties of merchantability or fitness for a particular purpose, are limited to one year or the shortest period allowed by law.

For US Customers: This limited warranty is extended to the original purchaser and any succeeding owner for products purchased for home use within the USA. If the product is located in an area where service by a Café Authorized Servicer is not available, you may be responsible for a trip charge or you may be required to bring the product to an Authorized **Café** Service location for service. In Alaska, the limited warranty excludes the cost of shipping or service calls to your home.

Some states do not allow the exclusion or limitation of incidental or consequential damages. This limited warranty gives you specific legal rights, and you may also have other rights which vary from state to state. To know what your legal rights are, consult your local or state consumer affairs office or your state's Attorney General.

Warrantor: GE Appliances, a Haier company
Louisville, KY 40225

For Customers in Canada: This limited warranty is extended to the original purchaser and any succeeding owner for products purchased in Canada for home use within Canada. In-home warrant service will be provided in areas where it is available and deemed reasonable by Mabe to provide.

Warrantor Canada: MC Commercial, Inc., Burlington, Ontario, L7R 5B6

Staple your receipt here. Proof of the original purchase date is needed to obtain service under the warranty.

Performance Data Sheet

Model: GE Appliances XWFE

- System certified by IAPMO R&T against NSF/ANSI Standards 42, 53, 401, and P473 for the reduction of claims specified on the performance data sheet and at iapmort.org.
- Actual performance may vary with local water conditions.

Substance Tested for Reduction	Influent challenge concentration (mg/L)	Maximum permissible product water concentration (mg/L)	Avg % Reduction
Chlorine Taste and Odor	2.0 mg/L +/- 10%	N/A	96.9
Chloramine Taste and Odor	3.0 mg/L +/- 10%	0.5	96.9
Particulate, Class I	At least 10,000/mL	N/A	91.4
Cysts	50,000/L	N/A	>99.99
Lead	0.15	0.01	98.85
Mercury	0.006	0.002	96.3
Asbestos	107 to 108 fibers/ L	N/A	>99
Toxaphene	0.015 +/- 10%	0.003	86.95
VOC (Chloroform surrogate chemical)	0.300	0.015	99.7
Alachlor	0.050	0.001	> 98
Atrazine	0.100	0.003	> 97
Benzene	0.081	0.001	> 99
Carbofuran	0.190	0.001	> 99
carbon tetrachloride	0.078	0.0018	98
chlorobenzene	0.077	0.001	> 99
chloropicrin	0.015	0.0002	99
2,4-D	0.110	0.0017	98
dibromochloropropane (DBCP)	0.052	0.00002	> 99
o-Dichlorobenzene	0.08	0.001	> 99
p-Dichlorobenzene	0.040	0.001	> 98
1,2-dichloroethane	0.088	0.0048	95
1,1-dichloroethylene	0.083	0.001	> 99
cis-1,2-dichloroethylene	0.170	0.0005	> 99
trans-1,2-dichloroethylene	0.086	0.001	> 99
1,2-dichloropropane	0.080	0.001	> 99
cis-1,3-dichloropropylene	0.079	0.001	> 99
dinoseb	0.170	0.0002	99
Endrin	0.053	0.00059	99
Ethylbenzene	0.088	0.001	> 99
ethylene dibromide (EDB)	0.044	0.00002	> 99
bromochloroacetonitrile	0.022	0.0005	98
dibromoacetonitrile	0.024	0.0006	98
dichloroacetonitrile	0.0096	0.0002	98
trichloroacetonitrile	0.015	0.0003	98
1,1-dichloro-2-propanone	0.0072	0.0001	99
1,1,1-trichloro-2-propanone	0.0082	0.0003	96
heptachlor (H-34, Heptox)	0.025	0.00001	>99
heptachlor epoxide	0.0107	0.0002	98
hexachlorobutadiene	0.044	0.001	> 98
hexachlorocyclopentadiene	0.060	0.000002	> 99
Lindane	0.055	0.00001	> 99
methoxychlor	0.050	0.0001	> 99
pentachlorophenol	0.096	0.001	> 99
simazine	0.120	0.004	> 97
Styrene	0.150	0.0005	> 99
1,1,2,2-tetrachloroethane	0.081	0.001	> 99
Tetrachloroethylene	0.081	0.001	> 99
Toluene	0.078	0.001	> 99
2,4,5-TP (silvex)	0.270	0.0016	99
tribromoacetic acid	0.042	0.001	> 98
1,2,4-Trichlorobenzene	0.160	0.0005	> 99
1,1,1-trichloroethane	0.084	0.0046	95
1,1,2-trichloroethane	0.150	0.0005	> 99
trichloroethylene	0.180	0.0010	> 99
bromoform	0.300	0.015	95
bromodichloromethane	0.300	0.015	95
chlorodibromomethane	0.300	0.015	95
xylene	0.070	0.001	>99
Meprobamate	400 +/- 20%	60	95.5
Atenolol	200 +/- 20%	30	95.9
Carbamazepine	1400 +/- 20%	200	98.6
DEET	1400 +/- 20%	200	98.6
Metolachlor	1400 +/- 20%	200	98.7
Trimethoprim	140 +/- 20%	20	96.1
Linuron	140 +/- 20%	20	96.6
TCEP	5000 +/- 20%	700	98.1
TCPP	5000 +/- 20%	700	98.1
Phenytol	200 +/- 20%	30	96
Ibuprofen	400 +/- 20%	60	95.9
Naproxen	140 +/- 20%	20	96.5
Estrone	140 +/- 20%	20	97.1
Bisphenol A	2000 +/- 20%	300	99.1
Nonyl phenol	1400 +/- 20%	200	97.3

Application Guidelines/Water Supply Parameters

Service Flow	0.5 gpm (1.89 lpm)
Water Supply	Potable Water
Water Pressure	25-120 psi (172-827 kPa)
Water Temperature	33°F-100°F (0.6°C-38°C)
Capacity	170 gallons (643.5 liters)

It is essential that the manufacturer's recommended installation, maintenance and filter replacement requirements be carried out for the product to perform as advertised. See Installation Manual for Warranty information.

NOTE: While the testing was performed under standard laboratory conditions, actual performance may vary. Replacement Cartridge: XWFE. For estimated costs of replacement elements please visit our website at cafeappliances.com.

⚠ WARNING To reduce the risk associated with ingestion of contaminants:

- Do not use with water that is microbiologically unsafe or of unknown quality without adequate disinfection before and after the system. Systems certified for cyst reduction may be used on disinfected water that may contain filterable cysts.

NOTICE

To reduce the risk of water leakage or flooding, and to ensure optimal filter performance:

- Read and follow use instructions before installation and use of this system.
- Installation and use **MUST** comply with all state and local plumbing codes.
- Do not install if water pressure exceeds 120 psi (827 kPa). If your water pressure exceeds 80 psi (552 kPa), you **must** install a pressure-limiting valve. Contact a plumbing professional if you are uncertain how to check your water pressure.
- Do not install where water hammer conditions may occur. If water hammer conditions exist you **must** install a water hammer arrester. Contact a plumbing professional if you are uncertain how to check for this condition.
- Do not install on hot water supply lines. The maximum operating water temperature of this filter system is 100° F (38° C).
- Protect filter from freezing. Drain filter when temperatures drop below 33°F (0.6°C).
- Change the disposable filter cartridge every six months or sooner if you observe a noticeable reduction in water flow rate.
- Failure to replace the disposable filter cartridge at recommended intervals may lead to reduced filter performance and cracks in the filter housing, causing water leakage or flooding.
- This System has been tested according to NSF/ANSI 42, 53, 401, and P473 for the reduction of the substances listed below. The concentration of the indicated substances in water entering the system was reduced to a concentration less than or equal to the permissible limit for water leaving the system, as specified in NSF/ANSI 42, 53, 401, and P473.



XWFE System is certified by IAPMO R&T against NSF/ANSI Standards 42, 53, 401, and P473 for the reduction of claims specified on the performance data sheet and at iapmort.org.

Notes

Consumer Support

Café Website

Have a question or need assistance with your appliance? Try the Café website 24 hours a day, any day of the year! You can also shop for more great Café products and take advantage of all our on-line support services designed for your convenience. In the US: cafeappliances.com In Canada: cafeappliances.ca

Register Your Appliance

Register your new appliance on-line at your convenience! Timely product registration will allow for enhanced communication and prompt service under the terms of your warranty, should the need arise. You may also mail in the pre-printed registration card included in the packing material. In the US: cafeappliances.com/register
In Canada: cafeappliances.ca/registration

Schedule Service

Expert Café repair service is only one step away from your door. Get on-line and schedule your service at your convenience any day of the year. In the US: cafeappliances.com/service In Canada: cafeappliances.ca/service

Extended Warranties

Purchase a Café extended warranty and learn about special discounts that are available while your warranty is still in effect. You can purchase it on-line anytime. Café Service will still be there after your warranty expires.
In the US: cafeappliances.com/extended-warranty In Canada: cafeappliances.ca/extended-warranty

Parts and Accessories

Individuals qualified to service their own appliances can have parts or accessories sent directly to their homes (VISA, MasterCard and Discover cards are accepted). Order on-line today 24 hours every day.
In the US: cafeappliances.com/parts

Instructions contained in this manual cover procedures to be performed by any user. Other servicing generally should be referred to qualified service personnel. Caution must be exercised, since improper servicing may cause unsafe operation.

Customers in Canada should consult the yellow pages for the nearest Mabe service center, visit our website at cafeappliances.com/parts

Contact Us

If you are not satisfied with the service you receive from Café, contact us on our website with all the details including your phone number, or write to:

In the US: General Manager, Customer Relations | Café Appliances, Appliance Park | Louisville, KY 40225
cafeappliances.com/contact

In Canada: Director, Consumer Relations, Mabe Canada Inc. | Suite 310, 1 Factory Lane | Moncton, N.B. E1C 9M3
cafeappliances.ca/contact