



UNDER COUNTER BEVERAGE CENTER

Use and Care Guide and Installation Instruction

For questions about features, operation/performance, parts, accessories, or service, call: **1-800-422-1230**
or visit our website at... www.kitchenAid.com
In Canada, call: **1-800-807-6777**, or visit our website at... www.KitchenAid.ca

TABLE OF CONTENTS

BEVERAGE CENTER SAFETY	2
Proper Disposal of Your Old Beverage Center.....	3
INSTALLATION REQUIREMENTS	3
Tools and Parts	3
Location Requirements	3
Product Dimensions.....	4
Custom Overlay Panel	4
Handle (Optional)	5
Electrical Requirements	5
INSTALLATION INSTRUCTIONS	5
Unpack the Beverage Center	5
Custom Overlay Panel Installation	6
Installation and Door Closing.....	7
USING BEVERAGE CENTER	7
Controls	7
Normal Sounds	8
Stocking the Beverage Center	9
Wine Racks	9
Beverage Center Shelves	10
CARE AND CLEANING	10
Cleaning	10
Removing Base Grille	10
Vacation Care	11
Moving Care	11
TROUBLESHOOTING	11
ASSISTANCE	13
In the U.S.A.....	13
In Canada	13
Accessories	13

BEVERAGE CENTER SAFETY

Your safety and the safety of others are very important.

We have provided many important safety messages in this manual and on your appliance. Always read and obey all safety messages.



This is the safety alert symbol.

This symbol alerts you to potential hazards that can kill or hurt you and others.

All safety messages will follow the safety alert symbol and either the word "DANGER" or "WARNING." These words mean:

! DANGER

You can be killed or seriously injured if you don't **immediately** follow instructions.

! WARNING

You can be killed or seriously injured if you don't follow instructions.

All safety messages will tell you what the potential hazard is, tell you how to reduce the chance of injury, and tell you what can happen if the instructions are not followed.

IMPORTANT SAFETY INSTRUCTIONS

WARNING: To reduce the risk of fire, electric shock, or injury when using your beverage center, follow these basic precautions:

- Plug into a grounded 3 prong outlet.
- Do not remove ground prong.
- Do not use an adapter.
- Do not use an extension cord.
- Disconnect power before servicing.
- Replace all parts and panels before operating.
- Remove doors from your old beverage center.
- Use non flammable cleaner.
- Do not store or use petrol, flammable liquids or gas in the vicinity of this or other electrical appliances. The fumes can cause fires or explosions.
- Do not store explosive substances such as aerosol cans with a flammable propellant in this beverage center.
- Do not use or place electrical devices inside the beverage center compartments if they are not of the type expressly authorized by the manufacturer.
- Use two or more people to move and install beverage center.
- This appliance is not intended for use by persons (including children) with reduced physical, sensory or mental capabilities, or lack of experience and knowledge, unless they have been given supervision or instruction concerning use of the appliance by a person responsible for their safety.
- Children should be supervised to ensure that they do not play with the appliance.
- To avoid the risk of children becoming trapped and suffocating, do not allow them to play or hide inside the beverage center.
- If the power supply cord is damaged, it must be replaced by the manufacturer or its service agent or a similarly qualified person.
- Keep ventilation openings, in the appliance enclosure or in the built-in structure, clear of obstruction.
- Do not use mechanical devices or other means to accelerate the defrosting process, other than those recommended by the manufacturer
- Do not damage the refrigerant circuit.

SAVE THESE INSTRUCTIONS

Proper Disposal of your Old Beverage Center

WARNING: Risk of child entrapment. Before you throw away your old Beverage Center:

- Take off the door.
- Leave the shelves in place so that children may not easily climb inside.

⚠ WARNING

Suffocation Hazard

Remove doors or lid from your old appliance.

Failure to do so can result in death or brain damage.

IMPORTANT: Child entrapment and suffocation are not problems of the past. Junked or abandoned beverage centers are still dangerous – even if they will sit for “just a few days.” If you are getting rid of your old beverage centers, please follow these instructions to help prevent accidents.

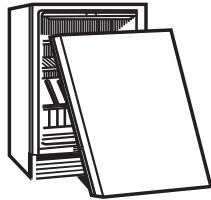

Important information to know about disposal of refrigerants:

Dispose of refrigerator in accordance with Federal and Local regulations. Refrigerants must be evacuated by a licensed, EPA certified refrigerant technician in accordance with established procedures.

INSTALLATION REQUIREMENTS

Tools and Parts

Gather the required tools and parts before starting installation.

Tools and parts needed:

- Phillips screwdriver.
- Custom Overlay Door Panel - Refer “Custom Overlay Panel Preparation”.
- Custom handle and mounting hardware (optional).

Parts supplied:

- M4 x 30 flathead screws (8).

Location Requirements

⚠ WARNING



Explosion Hazard

Keep flammable materials and vapors, such as gasoline, away from beverage center.

Failure to do so can result in death, explosion, or fire.

IMPORTANT: This appliance is intended to be used in household and similar applications such as:

- Staff kitchen areas in shops, office and other working environments;
- Farm houses and by clients in hotels, motels and other residential type environments;
- Bed and breakfast type environments;
- Catering and similar non-retail applications.

NOTES:

- For the beverage center to be flush with the front of the base cabinets, remove any baseboards or moldings from the rear of the opening. See “Product Dimensions” and later in this section, “Opening Dimensions”.
- It is recommended that you do not install the beverage center near an oven, radiator, or other heat source.
- Do not install in a location where the temperature will fall below 55 °F (13 °C). For best performance, do not install the beverage center behind a cabinet door or block the base grille.

Opening dimensions:

- Height dimensions are shown with the leveling legs extended to the minimum height.

NOTE: When leveling legs are fully extended, add 5/8” (15 mm) to the height dimensions. See “Product Dimensions.”

- If the floor of the opening is not level with the kitchen floor, shim the opening to make it level with the kitchen floor.

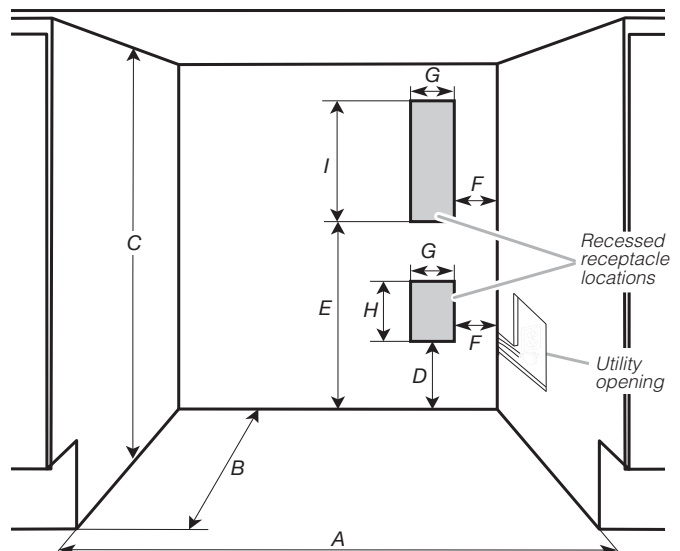

Opening and utility location dimensions	
Opening width - A	24" (60.96 cm) min.
Opening depth - B	24" (60.96 cm) min.
Opening height - C	34 ¹ / ₂ " (87.6 cm) min. 35" (88.9 cm) max.
Dimension - D	12 ¹ / ₁₆ " (30.64 cm)
Dimension - E	21 ³ / ₄ " (55.16 cm)
Dimension - F	1 ³ / ₄ " (4.44 cm)
Dimension - G	3" (7.55 cm)
Dimension - H	4 ¹ / ₂ " (11.37 cm)
Dimension - I	9 ¹ / ₄ " (23.47 cm)

For flush installation, the power outlet can be installed in adjacent cabinetry with a cutout on the power cord side for routing of the power cord.

The power outlet can also be recessed on the back wall behind the unit as per recommended receptacle locations in the above illustration.

Product Dimensions

Overall product	
Width (up to hinge cover)	23 ⁷ / ₈ " (60.72 cm)
Height (up to hinge cover)	34 ³ / ₈ " (87.32 cm)
Panel ready models depth (with 3/4" panel and no handle)	23 ¹³ / ₁₆ " (60.5 cm)
Raw Door Height	30 ⁵ / ₈ " (77.75 cm)
Depth (no handle)	23 ⁵ / ₈ " (60.01 cm)

NOTE: The power cord is 60" (152.4 cm) long.

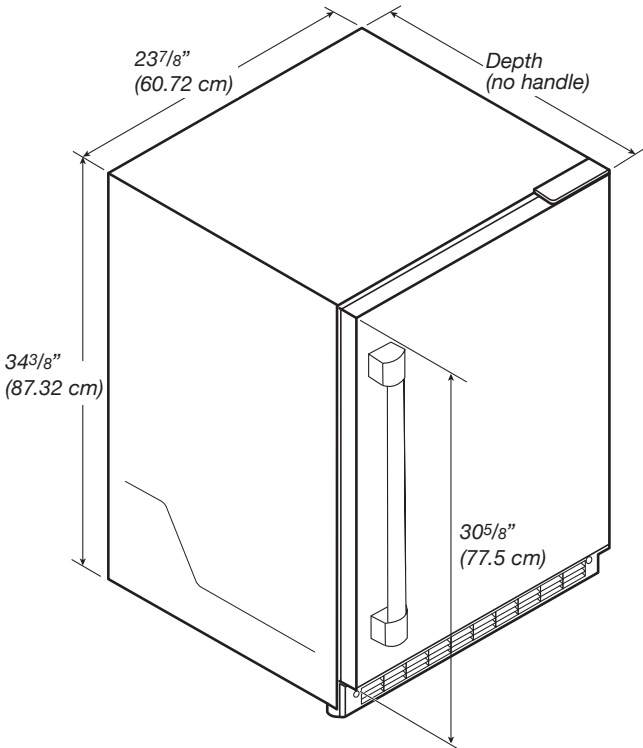

Custom Overlay Panel

NOTE: For standard stainless steel or glass door models, skip these instructions and go to "Electrical Requirements" section.

If you plan to install a custom overlay panel, you will need to create the panel yourself or consult a qualified cabinet maker or carpenter. Refer dimension drawings for panel specifications.

IMPORTANT:

- The thickness of the overlay panel must be 3/4" (19 mm).
- Custom solid door overlay panel must not weigh more than 20 lb (9.07 kg).
- Custom glass door overlay panel must not weigh more than 10 lb (4.54 kg).
- Overlay panels weighing more than recommended may cause damage to your appliance.

Solid door overlay panel - Preparation:

Create the custom overlay panel using the dimensions shown in the illustration "Solid door overlay panel and hinge routing dimensions". Route shaded areas to a 1/2" (12 mm) depth as shown.

IMPORTANT: The following graphic shows a custom panel for a door with the hinges installed on the right-hand side. If your beverage center has the hinges installed on the left-hand side, rotate the custom frame 180° so the hinge markings will be on the left.

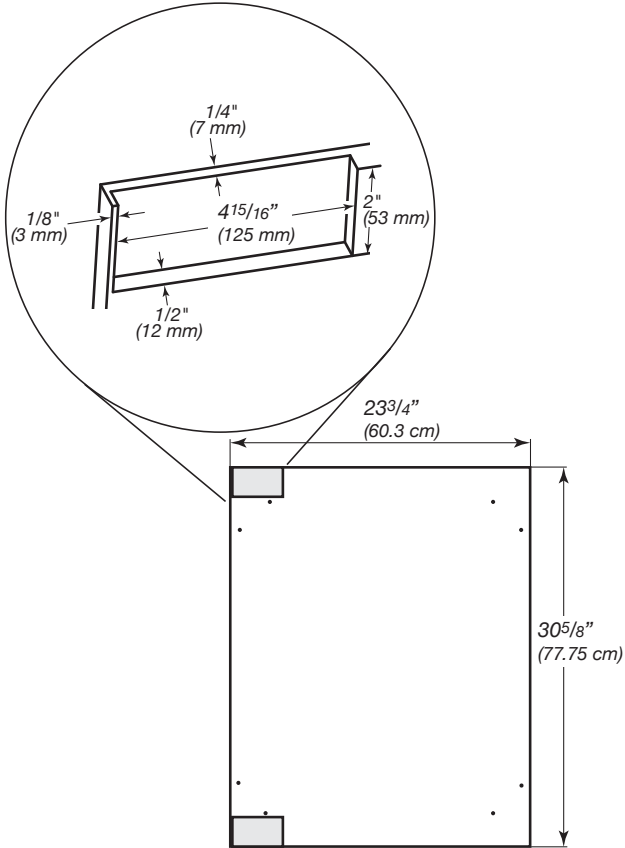

Solid door overlay panel and hinge routing dimensions

Glass door overlay panel - Preparation:

Create the custom overlay panel using the dimensions shown in the illustration "Glass door overlay panel and hinge routing dimensions". Route shaded areas to a 1/2" (12 mm) depth as shown.

IMPORTANT: The following graphic shows a custom panel for a door with the hinges installed on the right-hand side. If your beverage center has the hinges installed on the left-hand side, rotate the custom frame 180° so the hinge markings will be on the left.

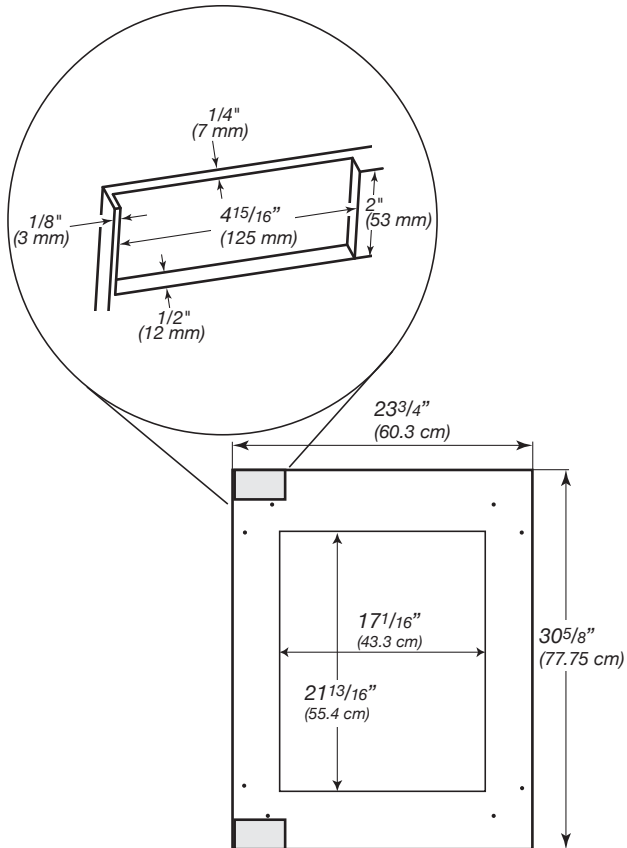

Glass door overlay panel and hinge routing dimensions

Handle (optional)

Custom handles are typically attached to the custom overlay door panel only.

Refer instructions received with KitchenAid handle kits to install these handles on custom wood panels.

Custom handle needs to be installed on the door panel with countersunk holes and installed before the custom overlay door panel has been installed on the beverage center door.

Electrical Requirements

⚠ WARNING



Electrical Shock Hazard

Plug into a grounded 3 prong outlet.

Do not remove ground prong.

Do not use an adapter.

Do not use an extension cord.

Failure to follow these instructions can result in death, fire, or electrical shock.

Before you move your beverage center into its final location, it is important to make sure you have the proper electrical connection.

Recommended grounding method:

A 115 V, 60 Hz, AC only, 15 A or 20 A fused, grounded electrical supply is required. It is recommended that a separate circuit serving only your beverage center be provided. Use an outlet that cannot be turned off by a switch. Do not use an extension cord.

NOTE: Before performing any type of installation, cleaning, or removing a light bulb, unplug beverage center or disconnect power.

INSTALLATION INSTRUCTIONS

Unpack the Beverage Center

⚠ WARNING

Excessive Weight Hazard

Use two or more people to move and install or uninstall appliance.

Failure to do so can result in back or other injury.

Before using your beverage center, all packaging materials should be removed and the interior should be cleaned.

- Remove tape and glue residue from surfaces before turning on the beverage center. With your fingers, rub a small amount of liquid dish soap over any adhesive and wipe with warm water to remove.
- Do not use sharp instruments, rubbing alcohol, flammable fluids, or abrasive cleaners to remove tape or glue. These can damage the surfaces of your beverage center. For more information, refer "Beverage Center Safety" section.

- Dispose of and/or recycle all packaging materials.
- After all packaging materials have been removed, clean the inside of your beverage center. Refer the cleaning instructions in "Cleaning" section.

NOTE: For standard stainless steel or glass door models, skip to "Door Closing" section.

Custom Overlay Panel Installation

IMPORTANT:

- Create custom overlay panel according to the specifications in the "Custom Overlay Panel" section.
- KitchenAid is not responsible for the removal or addition of molding or decorative panels that would not allow access to the beverage center for service.

1. Open the door completely to 115°.

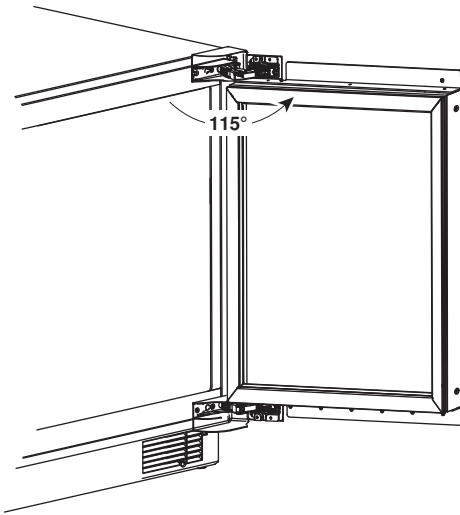

2. Remove the gasket from the corners of the door, pulling gently until the two screw holes in each corner of the door can be seen.

NOTE: The gasket does not have to be removed from the door, only the corners.

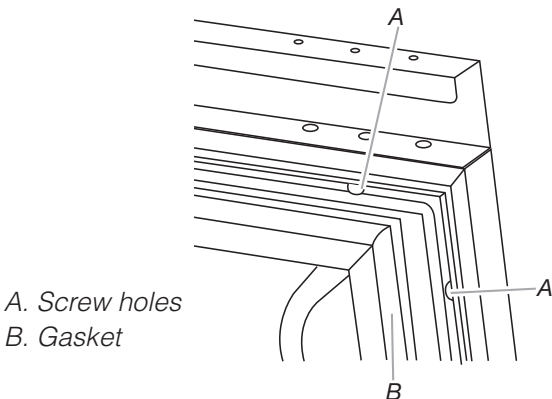

3. Using two people, hold the custom overlay panel against the door. Be sure that the top and bottom hinges fit accurately into the routing on back of the custom wood panel.

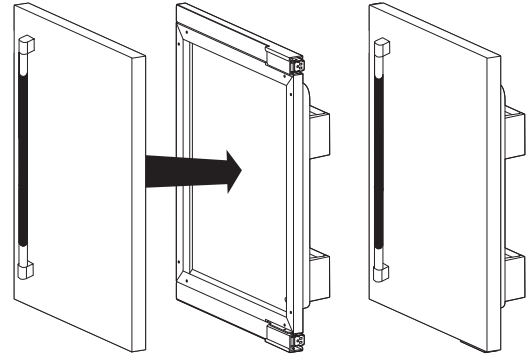

NOTE: Handle needs to be installed before the custom overlay door panel has been installed on the beverage center door.

4. Fasten the custom panel to the door using two wood screws (provided in installation kit) at each corner.

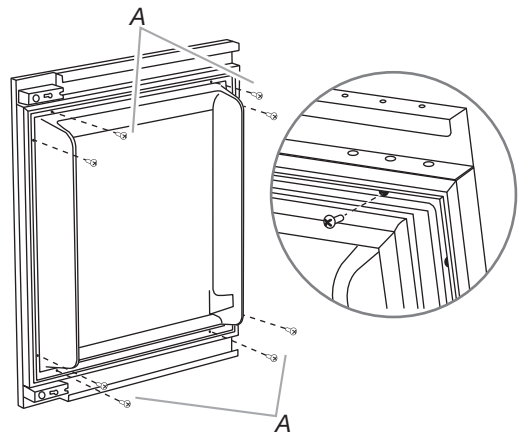

A. M4 x 30 flathead screws (provided in installation kit)

5. Press the gasket firmly back into its original position.

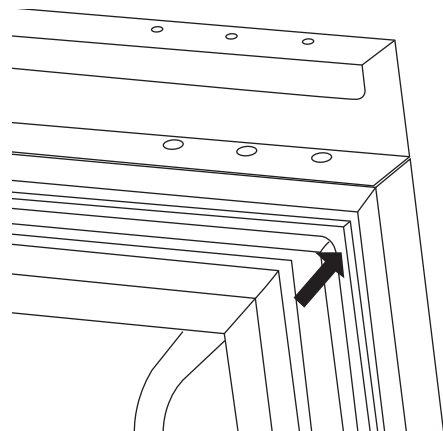

Installation and Door Closing

Your beverage center has four leveling legs. If your beverage center seems unsteady or you want the door to close more easily, adjust the beverage center's tilt using the instructions below.

⚠ WARNING



Electrical Shock Hazard

Plug into a grounded 3 prong outlet.

Do not remove ground prong.

Do not use an adapter.

Do not use an extension cord.

Failure to follow these instructions can result in death, fire, or electrical shock.

1. Plug into a grounded 3 prong outlet.

⚠ WARNING

Excessive Weight Hazard

Use two or more people to move and install or uninstall appliance.

Failure to do so can result in back or other injury.

When moving your Beverage Center:

Your beverage center is heavy. When moving the beverage center for cleaning or service, be sure to cover the door with cardboard or hardboard to avoid door damage. Always pull the beverage center straight out when moving it. Do not wiggle or "walk" the beverage center when trying to move it, as door damage could occur.

2. Move the beverage center into its final location.
3. Turn the leveling legs to the right to lower the beverage center, or turn the leveling legs to the left to raise it. It may take several turns of the leveling legs to adjust the tilt of the beverage center.

NOTE: Having someone push against the top of the beverage center takes some weight off the leveling legs. This makes it easier to adjust the leveling legs.

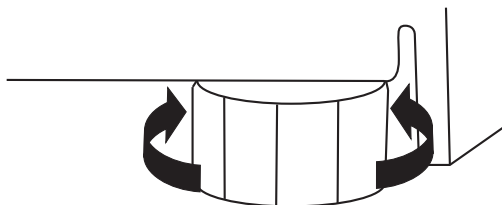

4. Open the door and check that it closes as easily as you like. If not, tilt the beverage center slightly more to the rear by turning both front leveling screws to the right. It may take several more turns, and you should turn both leveling legs the same amount.

USING BEVERAGE CENTER

Controls

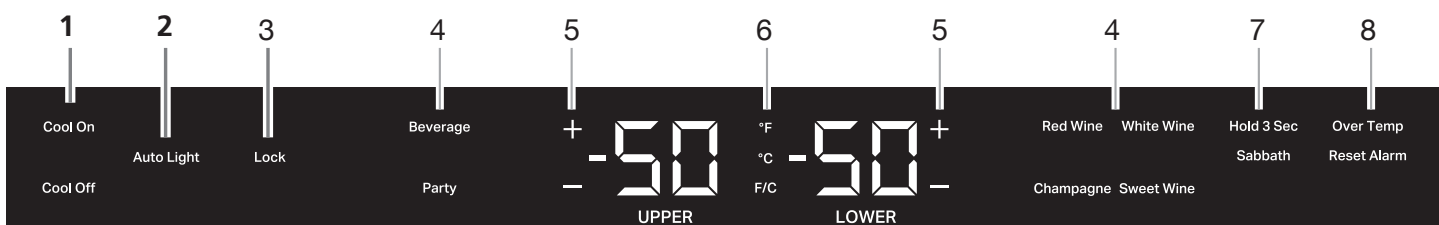

NOTES:

- When the beverage center is turned On for the first time, the temperature defaults to the recommended setting.
- There are two adjustable temperature controls, one for each compartment.
- The left temperature and preset touch pads control the temperature of the upper compartment.
- The right temperature and preset touch pads control the temperature of the lower compartment.

1. Turning Control On/Off

The first time that the beverage center is plugged in, the control will be in Cool Off mode. Cool On and Cool Off will be the only options that display.

Press COOL ON for 3 seconds to turn on the beverage center. All menus and recommended temperature settings will be displayed.

Cool On

Cool Off

2. Auto Light Option

Features a proximity sensor in the base grille that automatically ramps on the LED interior display lighting when motion is detected. When motion is no longer detected, the interior display light will turn off after 2 minutes.

Auto Light

- Press the AUTO LIGHT option to activate this feature.
- When the AUTO LIGHT is not activated, the interior display light will only turn on when the door is opened.

NOTE: Leaving the light on for an extended period of time will slightly increase the temperature of the beverage center.

3. Control Lock

A selectable feature that locks all controls except for Cool On and Cool Off.

To activate Lock Mode, press and hold LOCK for 3 seconds. After the countdown, all other displays will turn off and become unavailable except Cool On, Cool Off and Lock.

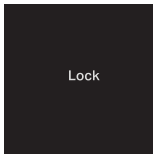

4. Using Presets



For your convenience, your beverage center also has controls that are preset to recommended storage temperature for specific beverages. Pressing any preset option will set the temperature to the recommended temperature for the specified beverage:

Beverage: 34 °F (1 °C)
Party: 37 °F (3 °C)
Red wine: 64 °F (17 °C)
White wine: 50 °F (10 °C)
Sweet wine: 42 °F (5 °C)
Champagne: 46 °F (7 °C)

5. Adjusting the Temperatures

To adjust set point temperatures, press “+” (plus) or “-” (minus) until the desired temperature setting is reached. The control is set correctly when the beverages are as cold as you like it.

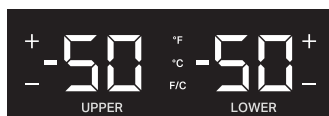

NOTES:

- The set point for the beverage center is 37 °F (3 °C) for the upper compartment and 50 °F (10 °C) for the lower compartment. The set point range for the upper compartment is 33 °F to 40 °F (0 °C to 4 °C) and 42 °F to 64 °F (5 °C to 17 °C) for the lower compartment.
- Wait at least 24 hours between adjustments for the product to acclimate. Recheck the temperatures before making further adjustments.

6. Viewing Celsius/Fahrenheit Temperatures

Press the F/C touch pad to toggle between displaying the temperature in degrees Fahrenheit and degrees Celsius. The corresponding indicator will illuminate.

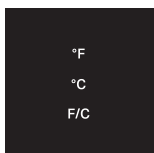

7. Sabbath Mode

Allows the door of the beverage center to be opened or closed during the Sabbath or other religious holidays without directly turning on or off any lights, digital

readouts, solenoids, fans, valves, icons, tones, alarms or the compressor. By selecting this feature, the temperature set points remain unchanged, but the control panel lights, interior lights, and control audio turn off. For most efficient beverage center operation, it is recommended to exit the Sabbath Mode when it is no longer required.

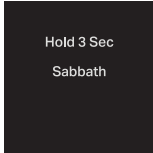

- Press and hold SABBATH for 3 seconds to turn on the feature. After the 3 second countdown, the feature will activate and all other displays will turn Off.
- Press and hold SABBATH for 3 seconds to turn off the feature and turn on the display.

8. Over Temperature Alarm

The Over Temperature feature is designed to let you know when the beverage center temperature rises above 70 °F (21 °C) for 4 hours or longer. The audio alarm will shut off automatically when the temperature returns to normal. To let you know an Over Temperature condition occurred, the indicator light will continue to flash until the Reset Alarm touch pad is pressed.

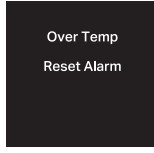

If the over temperature condition is still present when an Over Temp reset is performed, the indicator light will continue to reactivate every 4 hours until the beverage center temperature is below 70 °F (21 °C).

NOTE: These features will not appear on your control unless your beverage center is over temperature and the alarm requires a reset.

9. Max Cool

Plummets internal temperatures to their lowest point for 24 hours.

- Press “+” and “F/C” at the same time to turn on the feature. The feature will activate.
- Press “+” and “F/C” at the same time to turn off the feature. The feature will deactivate.

If it is not turned off as indicated, after 24 hrs it will be deactivated by itself.

10. Door Open Alarm

Helps avoid food and beverage spoilage by giving an audio and visual alert if the door is left open for 5 minutes.

If the door is open longer than 5 minutes, an alarm will sound every 2 minutes until the door is closed or any control is pressed.

11. Showroom Mode

This mode is used only when the beverage center is on display in a retail store. To activate Showroom Mode, press and hold both Cool On and Sabbath for 3 seconds. If you unintentionally turn on Showroom Mode, Cool Off will light up on the display, and the controls will appear to work. Exit Showroom Mode by pressing and holding COOL ON and SABBATH at the same time for 3 seconds.

Normal Sounds

Your new beverage center may make sounds that your old one didn't make. Because the sounds are new to you, you might be concerned about them. Most of the new sounds are normal. Hard surfaces, such as the flooring and surrounding

structures, can make the sounds seem louder. The following describes the kinds of sounds and what may be making them.

- Your beverage center is designed to run more efficiently to keep your beverages at the desired temperatures and to minimize energy usage. The high efficiency compressor and fans may cause your beverage center to run longer than your old one. You may also hear a pulsating or high-pitched sound from the compressor or fans adjusting to optimize performance.
- Rattling noises may come from the flow of refrigerant or items stored inside the beverage center.
- As each cycle ends, you may hear a gurgling sound due to the refrigerant flowing in your beverage center.
- You may hear water running into the drain pan when the beverage center is defrosting.
- You may hear clicking sounds when the beverage center starts or stops running.

Stocking the Beverage Center

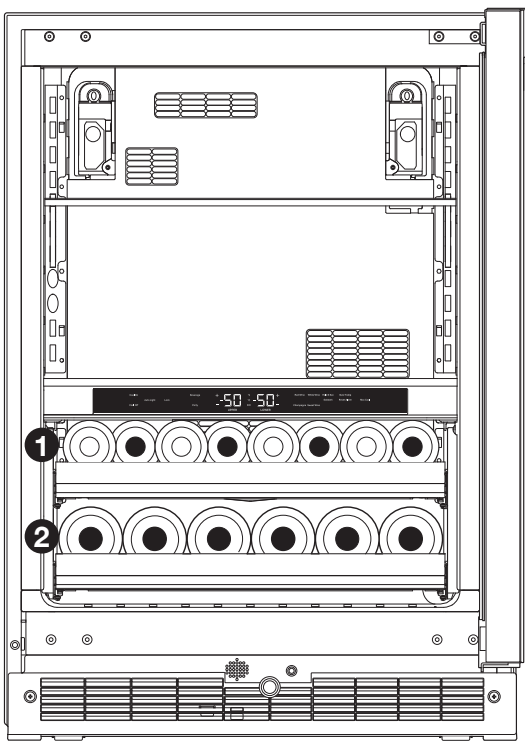

Rack 1: For storing up to eight 750 ml wine bottles [diameter less than or equal to 3¹/₈" (80 mm)].

Rack 2: For storing up to 6 wine bottles [diameter up to 3¹/₈" (80 mm)].

To stock the Beverage Center Shelves:

Place juices, sodas or other canned beverages on the glass shelves.

To stock the Beverage Center - Rack 1:

NOTE: The wine rack can be stocked with the bottles facing either direction, however, to optimize storage adjacent bottles should be facing in opposite.

1. Starting on the left-hand side, place the first bottle on the bottom of the rack with the neck of the bottle facing the front of the beverage center.
2. Place the next bottle on its side with the neck of the bottle facing the back of the beverage center. Alternate the direction of the bottles, in this manner, until the display rack is full.

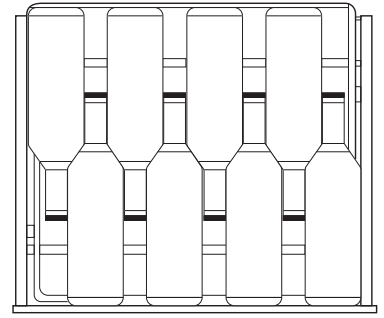

To stock the Beverage Center - Rack 2:

1. Starting from left-hand side of the bottom rack, place the first bottle with the neck of the bottle facing the front of the beverage center.
2. Continue to place the remaining bottles facing in the same direction.

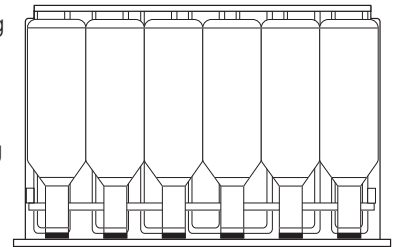

Wine Racks

Remove and replace the racks:

1. Pull the rack forward until it stops.
2. Press down on the left-hand lever while lifting up on the right-hand lever to release the rack. Pull the rack forward and lift it up and out of the rack supports.

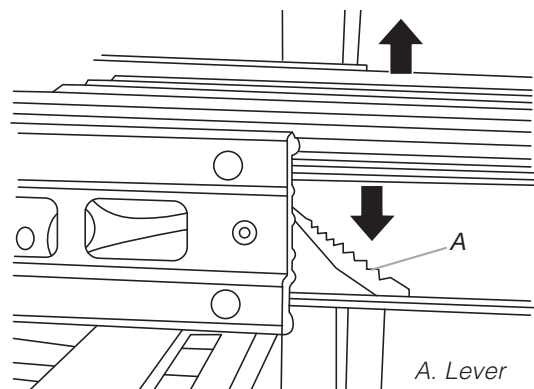

3. Replace the rack by inserting the rack into the supports and sliding it in until it locks.

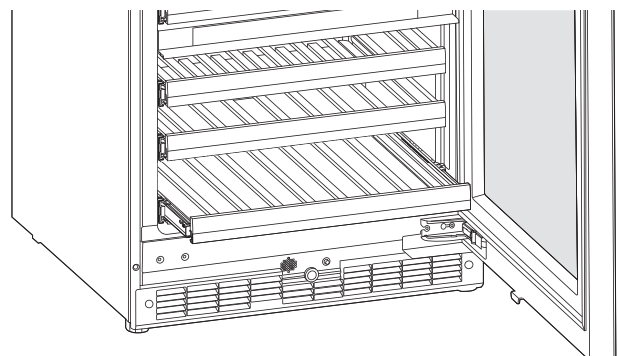

Beverage Center Shelves

Remove and replace the shelves:

1. Remove the shelf by lifting up the front and pulling it out of the shelf slots.
2. Replace the shelf by inserting it into the shelf slots and pushing it toward the back of the compartment.

Important information to know about glass shelves and covers:

Do not clean glass shelves or covers with warm water when they are cold. Shelves and covers may break if exposed to sudden temperature changes or impact, such as bumping. Tempered glass is designed to shatter into many small, pebble-size pieces. This is normal. Glass shelves and covers are heavy. Use both hands when removing them to avoid dropping.

CARE AND CLEANING

Cleaning

⚠ WARNING



Explosion Hazard

- Risk of fire or explosion.**
- Flammable refrigerant used.**
- Do not use mechanical devices to defrost refrigerator.**
- Do not puncture refrigerant tubing.**

Clean the beverage center once a month to avoid buildup of odors. Wipe up spills immediately.

To clean your Beverage Center:

1. Unplug beverage center or disconnect power.
2. Empty and remove all shelves and racks from inside the beverage center.
3. Hand wash, rinse, and dry removable parts and interior surfaces thoroughly. Use a clean sponge or soft cloth and a mild detergent in warm water.
 - To avoid damaging wooden tines and trim pieces, wipe them off with a clean sponge or soft cloth and warm water. Do not use detergent or immerse the entire rack into water when cleaning.
 - Do not use abrasive or harsh cleaners such as window sprays, scouring cleansers, flammable fluids, cleaning waxes, concentrated detergents, bleaches or cleansers containing petroleum products on plastic parts, interior and door liners or gaskets. Do not use paper towels, scouring pads, or other harsh cleaning tools. These can scratch or damage materials.

- To help remove odors, you can wash interior walls with a mixture of warm water and baking soda [2 tbs to 1 qt (26 g to 0.95 L) of water].
4. Wash stainless steel and painted metal exteriors with a clean sponge or soft cloth and a mild detergent in warm water. Do not use abrasive or harsh cleaners, or cleaners containing chlorine. These can scratch or damage materials. Dry immediately with a soft, dry cloth to absorb any remaining water.

NOTE: To keep your stainless steel beverage center looking like new and to remove minor scuffs or marks, it is recommended that you use the manufacturer's approved Stainless Steel Cleaner and Polish. To order the cleaner, refer "Accessories" section.

IMPORTANT:

- This cleaner is for stainless steel parts only!
 - Do not allow the Stainless Steel Cleaner and Polish to come into contact with any plastic parts such as the trim pieces, dispenser covers or door gaskets. If unintentional contact does occur, clean plastic part with a sponge and mild detergent in warm water. Dry immediately with a soft, dry cloth to absorb any remaining water.
5. Replace the racks.

Condenser cleaning

⚠ WARNING



Explosion Hazard

- Risk of fire or explosion due to puncture of refrigerant tubing.**
- Follow handling instructions carefully.**
- Flammable refrigerant used.**

1. Remove the base grille to access condenser for cleaning. Refer "Removing Base Grille" section.
2. Clean the condenser coils regularly. They are located behind the base grille. Coils may need to be cleaned as often as every other month. This may help save energy.

Removing Base Grille

You must remove the base grille to access the condenser coils for cleaning.

To remove the base grille:

1. Open the beverage center door.

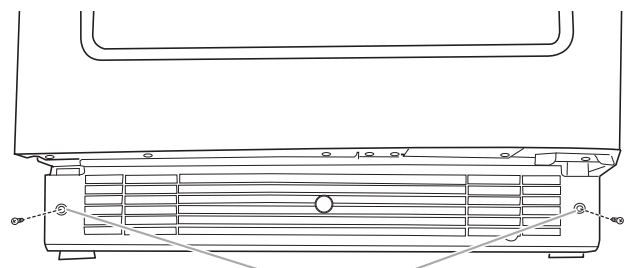

A. Screws

2. Using a Phillips screwdriver, remove the two screws.
3. Remove the base grille.

To replace the base grille:

1. Open the beverage center door.
 2. Position the base grille so that both tabs align and the base grille snaps into place. Replace two screws. Tighten the screws.
-

Vacation Care

If you choose to turn the beverage center off before you leave, follow these steps.

1. Remove all beverage contents from the beverage center.
2. Unplug the beverage center.
3. Clean the beverage center. Refer "Cleaning" section.
4. Tape a rubber or wood block to the top of the door to prop it open far enough for air to get in. This stops odor and mold from building up.

Moving Care

When you are moving your beverage center to a new home, follow these steps to prepare it for the move.

1. Remove all beverage contents from the beverage center.
2. Unplug the beverage center.
3. Clean, wipe, and dry it thoroughly.
4. Take out all removable parts, wrap them well, and tape them together so they don't shift and rattle during the move.
5. Tape the doors shut and tape the power cord to the beverage center.

When you get to your new home, put everything back and refer to the "Installation Instructions" received with the beverage center.

TROUBLESHOOTING

Try the solutions suggested here first in order to avoid the cost of an unnecessary service call.

⚠ WARNING



Electrical Shock Hazard

Plug into a grounded 3 prong outlet.

Do not remove ground prong.

Do not use an adapter.

Do not use an extension cord.

Failure to follow these instructions can result in death, fire, or electrical shock.

GENERAL OPERATION

Possible Causes and/or Recommended Solutions

Beverage center will not operate

- **Power supply cord unplugged?** Plug into a grounded 3 prong outlet.
- **Is outlet working?** Plug in a lamp to see if the outlet is working.
- **Household fuse blown, or a circuit breaker tripped?** Replace the fuse or reset the circuit. If the problem continues, call an electrician.
- **Are controls on?** Be sure that the beverage center controls are on. Refer "Controls" section.

The motor seems to run too much

- **Is the temperature outside hotter than normal?** Expect the motor to run longer under warm conditions. At normal temperatures, expect your motor to run about 40 % to 80 % of the time. Under warmer conditions, expect it to run even more of the time.
- **Is the door opened often?** Expect the motor to run longer when this occurs. In order to conserve energy, try to get everything you need out of the Beverage Center at once, keep food organized so it is easy to find, and close the door as soon as the food is removed.

GENERAL OPERATION**Possible Causes and/or Recommended Solutions**

The motor seems to run too much

- **Is the control set correctly for the surrounding conditions?** Refer “Controls” section.
- **Is the door closed completely?** Push the door firmly shut. If it will not shut all the way, refer “The door will not close completely” later in this section.
- **Are the condenser coils dirty?** This obstructs air transfer and makes the motor work harder. Clean the condenser coils. Refer “Cleaning” section.

TEMPERATURE AND MOISTURE**Possible Causes and/or Recommended Solutions**

Temperature is too warm

- **Is the door opened often?** Be aware that the Beverage Center will warm when this occurs. In order to keep the Beverage Center cool, try to get everything you need out of the Beverage Center at once, keep beverage contents organized so it is easy to find, and close the door as soon as the content is removed.
- **Is the control set correctly for the surrounding conditions?** Refer “Controls” section.
- **Is the base grille blocked?** For best performance, do not install the beverage center behind a cabinet door or block the base grille.

There is interior moisture buildup

- **Is the door opened often?** To avoid humidity buildup, try to get everything you need out of the Beverage Center at once, keep beverage contents organized so it is easy to find, and close the door as soon as the content is removed. When the door is opened, humidity from the room air enters the Beverage Center. The more often the door is opened, the faster humidity builds up, especially when the room itself is very humid.
- **Is it humid?** It is normal for moisture to build up inside the beverage center when the air is humid.
- **Is the control set correctly for the surrounding conditions?** Refer “Controls” section.

DOOR**Possible Causes and/or Recommended Solutions**

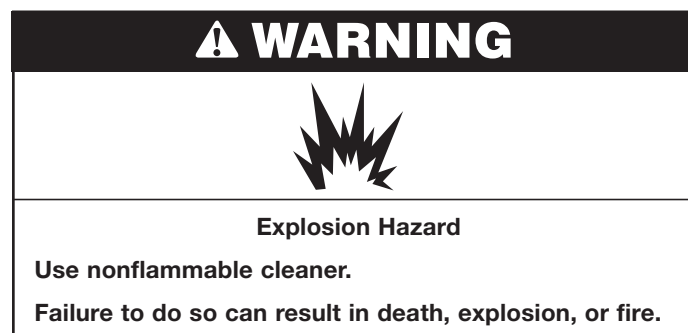
**The door is difficult to open**

- **Are beverage contents blocking the door open?** Rearrange beverage contents so that they fit more tightly and take up less space.
- **Are the shelves out of position?** Put the shelves back into their correct positions. See “Beverage Center Use” for more information.
- **Is the gasket dirty or sticky?** Clean the gasket and the surface that it touches. Rub a thin coat of paraffin wax on the gasket following cleaning.

The door will not close completely

- **Are the racks out of position?** Put the racks back into their correct positions. Refer “Wine Racks” section for more information.
- **Is the gasket sticking?** Clean the gasket and the surface that it touches. Rub a thin coat of paraffin wax on the gasket following cleaning.

ASSISTANCE

If you need service:

Before calling for assistance or service, please check "Troubleshooting." It may save you the cost of a service call. If you still need help, follow the instructions below.

When calling, please know the purchase date and the complete model and serial number of your appliance. This information will help us to better respond to your request. Please refer to the warranty page in this manual for more information on service.

If you need replacement parts:

Component parts should be replaced with like components and servicing should be done by factory authorized service personnel, so as to minimize the risk of possible ignition due to incorrect parts or improper service.

In the U.S.A.

Call the KitchenAid Customer eXperience Center toll free: **1-800-422-1230**.

Our Consultants Provide Assistance With:

- Features and specifications on our full line of appliances.
- Installation information.
- Use and maintenance procedures.
- Accessory and repair parts sales.
- Specialized customer assistance (Spanish speaking, hearing impaired, limited vision, etc.).
- Referrals to local dealers, repair parts distributors, and service companies. KitchenAid designated service technicians are trained to fulfill the product warranty and provide after-warranty service, anywhere in the United States.

To locate the KitchenAid designated service company in your area, you can also look in your telephone directory Yellow Pages.

For Further Assistance

If you need further assistance, you can write to KitchenAid with any questions or concerns at:

KitchenAid Brand Home Appliances
Customer eXperience Center
553 Benson Road
Benton Harbor, MI 49022-2692

Please include a daytime phone number in your correspondence.

In Canada

Call the KitchenAid Canada Customer eXperience Centre toll free: **1-800-807-6777**.

Our Consultants Provide Assistance With:

- Features and specifications on our full line of appliances.
- Use and maintenance procedures.
- Accessory and repair parts sales.
- Referrals to local dealers, repair parts distributors, and services companies. KitchenAid Canada designated service technicians are trained to fulfill the product warranty and provide after-warranty service, anywhere in Canada.

For Further Assistance

If you need further assistance, you can write to KitchenAid Canada with any questions or concerns at:

KitchenAid Canada
Customer eXperience Centre
200 – 6750 Century Ave.
Mississauga, Ontario L5N 0B7

Please include a daytime phone number in your correspondence.

Accessories

The following accessories are available for your beverage center.

To order an accessory, contact us and ask for the Part Number.

In the U.S.A., visit our webpage **www.kitchenaid.com/accessories** or call **1-800-442-9991**.

In Canada, visit our webpage **www.whirlpoolparts.ca** or call **1-800-807-6777**.

Stainless Steel Cleaner and Polish

Order Part #4396095

