



ROOM AIR CONDITIONER

SAFETY INFORMATION3

OPERATING INSTRUCTIONS....5

CARE AND CLEANING.....7

INSTALLATION INSTRUCTIONS .8

TROUBLESHOOTING TIPS.....13

WIFI SETUP14

LIMITED WARRANTY17

CONSUMER SUPPORT18

OWNER'S MANUAL & INSTALLATION INSTRUCTIONS

AHY08
 AHY10
 AHY12
 AHY14

ENGLISH/ESPAÑOL

Before you begin

Record the GE module number and password for wifi setup. To locate this information, see page 14.

GE Module Number # _____

Password # _____

Write the model and serial numbers here:

Model # _____

Serial # _____

You can find the rating label on the side of the air conditioner.

THANK YOU FOR MAKING GE APPLIANCES A PART OF YOUR HOME.

Whether you grew up with GE Appliances, or this is your first, we're happy to have you in the family.

We take pride in the craftsmanship, innovation and design that goes into every GE Appliances product, and we think you will too. Among other things, registration of your appliance ensures that we can deliver important product information and warranty details when you need them.

Register your GE appliance now online. Helpful websites and phone numbers are available in the Consumer Support section of this Owner's Manual. You may also mail in the pre-printed registration card included in the packing material.



IMPORTANT SAFETY INFORMATION

READ ALL INSTRUCTIONS BEFORE USING THE APPLIANCE

▲ WARNING

For your safety, the information in this manual must be followed to minimize the risk of fire, electric shock or personal injury.

- Use this appliance only for its intended purpose as described in this Owner's Manual.
- This air conditioner must be properly installed in accordance with the Installation Instructions before it is used.
- Never unplug your air conditioner by pulling on the power cord. Always grip plug firmly and pull straight out from the receptacle.
- Replace immediately all electric service cords that have become frayed or otherwise damaged. A damaged power supply cord must be replaced with a new power supply cord obtained from the manufacturer and not repaired. Do not use a cord that shows cracks or abrasion damage along its length or at either the plug or connector end.
- Turn the unit OFF and unplug your air conditioner before cleaning.
- For your safety...do not store or use combustible materials, gasoline or other flammable vapors or liquids in the vicinity of this or any other appliance.
- If the receptacle does not match the plug, the receptacle must be changed out by a qualified electrician.



WARNING

Risk of Fire or Explosion. This unit contains flammable refrigerant. Additional safety precautions must be followed.

- Do not use means to accelerate the defrosting process or to clean, other than those recommended by the manufacturer.
- The appliance shall be stored in a room without continuously operating ignition sources (for example: open flames, an operating gas appliance or an operating electric heater).
- Do not pierce or burn refrigerant tubing. Be aware that refrigerants may not contain an odor.
- Keep ventilation openings clear of obstruction.
- When handling, installing, and operating the appliance, care should be taken to avoid damage to the refrigerant tubing.
- Do not drill holes in the unit.
- Maintenance, cleaning, and service should only be performed by technicians properly trained and qualified in the use of flammable refrigerants.
- GE Appliances does not support any servicing of the air conditioner.
- Dispose of air conditioner in accordance with Federal and Local Regulations. Flammable refrigerants require special disposal procedures. Contact your local authorities for the environmentally safe disposal of your air conditioner.

READ AND SAVE THESE INSTRUCTIONS

IMPORTANT SAFETY INFORMATION

READ ALL INSTRUCTIONS BEFORE USING THE APPLIANCE

▲ WARNING USE OF EXTENSION CORDS

RISK OF FIRE. Could cause serious injury or death.

- DO NOT use an extension cord with this Window Air Conditioner.

- DO NOT use surge protectors or multi-outlet adaptors with this Window Air Conditioner.

HOW TO CONNECT ELECTRICITY

Do not, under any circumstances, cut or remove the third (ground) prong from the power cord. For personal safety, this appliance must be properly grounded.

DO NOT use an adapter plug with this appliance.

The power cord of this appliance is equipped with a 3-prong (grounding) plug which mates with a standard 3-prong (grounding) wall outlet to minimize the possibility of electric shock hazard from this appliance.

Power cord includes a current interrupter device. A test and reset button is provided on the plug case. The device should be tested on a periodic basis by first pressing the **TEST** button and then the **RESET** button while plugged into the outlet. If the **TEST** button does not trip or if the **RESET** button will not stay engaged, discontinue use of the air conditioner and contact a qualified service technician.

Have the wall outlet and circuit checked by a qualified electrician to make sure the outlet is properly grounded.

Where a 2-prong wall outlet is encountered, it is your personal responsibility and obligation to have it replaced with a properly grounded 3-prong wall outlet.

The air conditioner should always be plugged into its own individual electrical outlet which has a voltage rating that matches the rating plate.

This provides the best performance and also prevents overloading house wiring circuits which could cause a fire hazard from overheated wires.

See the Installation Instructions, **Electrical Requirements** section for specific electrical connection requirements.

▲ WARNING Chemical Burn Hazard. Keep batteries away from children.

- This product contains a lithium button/coin cell battery. If a new or used lithium button/coin cell battery is swallowed or enters the body, it can cause severe internal burns and can lead to death in as little as 2 hours. Always completely secure the battery compartment. If the battery compartment does not close securely, stop using the product, remove the batteries, and keep it away from children.
- If you think batteries might have been swallowed or placed inside any part of the body, seek immediate medical attention.
- The cells shall be disposed of properly, including keeping them away from children.
- Even used cells may cause injury.

READ AND SAVE THESE INSTRUCTIONS

Controls

Features and appearance will vary.

Lights beside the touch pads on the air conditioner control panel indicate the selected settings.

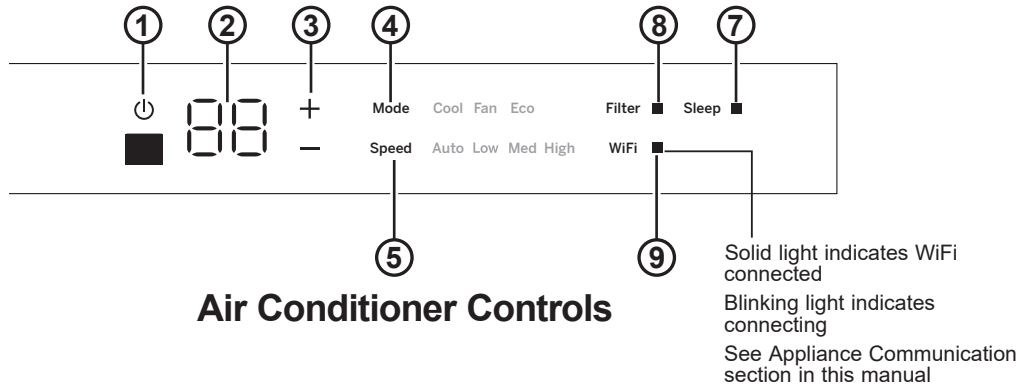

Air Conditioner Controls

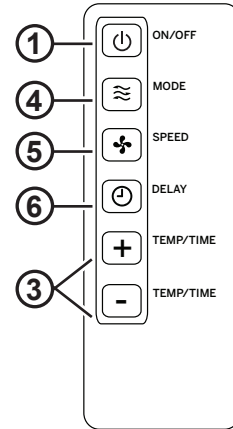

Remote Control

1. Power Pad

Turns air conditioner on and off. When turned on, the display will show the room temperature.

2. Display

Shows the room temperature or time remaining on the Delay timer. Shows the **Set** temperature while setting the temperature in **Cool** or **Eco** modes.

3. Temp and Delay Increase + /Decrease - Pads

Use to set temperature or delay time. Temperature can be set in **Cool** and **Eco** mode.

4. Mode Pad

Use to set the air conditioner to **Fan Only**, **Cool**, or **Eco** mode.

5. Fan Speed Pad

In **Cool** or **Eco** mode: Use to set the fan speed to **Auto**, **High**, **Med** or **Low** on the unit.

In **Fan Only** mode: Use to set the fan speed to **High**, **Med**, or **Low** on the unit.

6. Delay Pad (set by remote control only)

Delay ON—When the air conditioner is off, it can be set to automatically come on in 1 to 24 hours at its previous mode and fan settings.

Delay OFF—When the air conditioner is on, it can be set to automatically turn off in 1 to 24 hours.

How to set:

Press the **Delay** pad on the remote control. Each touch of the **Increase + / Decrease -** pads on the remote control will set the timer in 1-hour intervals.

To review the remaining time on the **Delay** timer, press the **Delay** pad on the remote control. Use the **Increase + / Decrease -** pads on the remote control to set a new time if desired.

To cancel the timer, press **Decrease -** pad on the remote control until the set time is zero.

7. Sleep Pad (set by air conditioner controls only)

The **SLEEP** mode sets the unit to gradually change settings over an 8 hour period to allow for some increased energy efficiency during sleep hours.

The **SLEEP** mode is available only in **COOL** and **FAN** only settings.

Press the **SLEEP** mode pad and its light will illuminate. The fan indicator will stay at the same setting but the air conditioner will automatically change the **FAN** speed to low in either **COOL** or **FAN** only mode.

In **FAN** only mode, the fan will stay in the **LOW** speed setting for 8 hours. After 8 hours, the air conditioner will resume the settings that were in place before the **SLEEP** mode pad was pressed.

In **COOL** mode, the fan will stay in the **LOW** speed setting for 8 hours from the time the **SLEEP** mode pad was pressed. The air conditioner will also raise the set point 2°F in 30 minutes and 2°F more in another 30 minutes where it will remain for the next 7 hours. After 8 hours, the air conditioner will resume the settings that were in place before the **SLEEP** mode pad was pressed.

While the unit is in **SLEEP** mode, pressing any pad will return it to the settings that were in place before the **SLEEP** mode pad was pressed.

8. Filter Reset Pad

This feature automatically notifies you that the air filter must be cleaned. The indicator light will come on after 250 hours of operation. Clean the air filter (refer to page 6), place it back in the front panel, and press the **Filter Reset** pad. The light will go off.

9. WiFi Connect Pad

Enables connection of the air conditioner to the home WiFi. Download App for details at: www.GEAppliances.com/connect.

Using the Air Conditioner

Do Not Operate in Freezing Outdoor Conditions

This cool-only air conditioner was not designed for freezing outdoor conditions.

It must not be used when the outdoor temperature is below freezing (32°F).

Control Panel Lights On/Off Feature

This air conditioner has a control panel lights on/off feature where its lights will turn off when there is no activity with the controls for over one minute. To wake up the controls, press any pad on the controls and the lights will come on to show the previous settings.

To turn this feature off, press and hold the **SLEEP** pad, on the unit, for 5 seconds. The unit will beep to signal the successful toggle of the feature on and off.

Remote Control

- To ensure proper operation, aim the remote control at the signal receiver on the air conditioner.
 - The remote control signal has a range of up to 20 feet.
 - Make sure nothing is between the air conditioner and the remote control that could block the signal.
 - Make sure batteries are fresh and installed correctly as indicated on the remote control.
-

Cool Mode

Use the Cool mode at **Low, Med, High** or **Speed** for cooling. Use the **Temperature Increase + / Decrease -** pads to set the desired temperature between 64°F and 86°F in 1°F increments.

An electronic thermostat is used to maintain the room temperature. The compressor will cycle on and off to keep the room at the set level of comfort. Set the thermostat at a lower number and the indoor air will become cooler. Set the thermostat at a higher number and the indoor air will become warmer.

NOTE: If the air conditioner is off and is then turned on while set to a **Cool** setting or if turned from a fan setting to a **Cool** setting, it may take approximately 3 minutes for the compressor to start and cooling to begin.

Cooling Descriptions

For Normal Cooling—Select the **Cool** mode and **High** or **Med** fan with a middle set temperature.

For Maximum Cooling—Select the **Cool** mode and **High** fan with a lower set temperature.

For Quieter and Nighttime Cooling—Select the **Cool** mode and **Low** fan with a middle set temperature.

Eco Mode

Controls the fan.

ON—The fan will cycle on and off with the compressor. This may result in wider variations of room temperature and humidity. **NOTE:** the fan may continue to run for a short time or may pulse intermittently after the compressor cycles off to sample the room air.

OFF—The fan runs all the time, while the compressor cycles on and off.

Fan Only Mode

Use the Fan Only Mode at Low, Med or High fan speed to provide air circulation and filtering without cooling. Since fan-only settings do not provide cooling, a Set temperature cannot be entered. The room temperature will appear in the display.

Auto Fan Mode

Set to **Auto** for the fan speed to automatically set to the speed needed to provide optimum comfort settings with the set temperature.

If the room needs more cooling, the fan speed will automatically increase. If the room needs less cooling, the fan speed will automatically decrease.

Using the Air Conditioner

Air Direction

Use the levers to adjust the air direction left or right. Tilt the louver bank to adjust up and down.

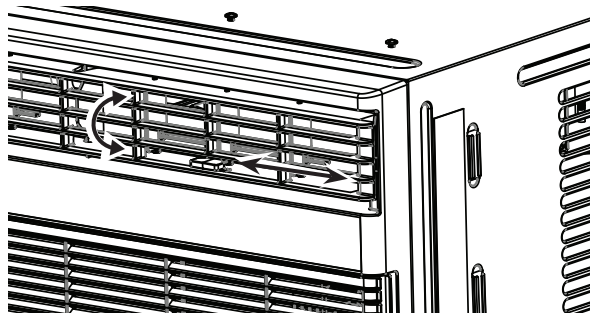

Care and Cleaning

Grille and Case

Turn the air conditioner off and remove the plug from the wall outlet before cleaning.

To clean, use water and a mild detergent. Do not use bleach or abrasives.

Air Filter

The air filter behind the front grille should be checked and cleaned at least every 30 days or more often if necessary.

To remove:

Open the inlet grille by pulling downward on the tabs at the top upper corners of the inlet grille until the grille is in a 45° position. Remove the filter.

Clean the filter with warm, soapy water. Rinse and let the filter dry before replacing it. Do not clean the filter in a dishwasher.

CAUTION DO NOT operate the air conditioner without a filter because dirt and lint will clog it and reduce performance.

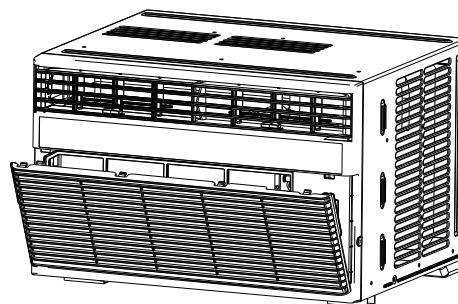

Outdoor Coils

The coils on the outdoor side of the air conditioner should be checked regularly. If they are clogged with dirt or soot, they may be professionally cleaned.

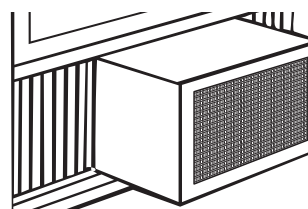

How to Insert the Battery in the Remote Control

1. Remove the screw on the back of the battery cover.
2. Pinch the slide lock and pull the battery tray out at the same time.
3. Insert new battery, making sure that the (+) and (-) of battery are installed correctly.
4. Reinsert the battery tray and reinstall the screw.

NOTES:

- Use one CR 2025 (3V) Lithium battery.
- Remove the battery from the remote control if the system is not going to be used for a long time.

Installation Instructions

Questions? Call 800.GE.CARES (800.432.2737) or Visit our Website at: GEAppliances.com

BEFORE YOU BEGIN

Read these instructions completely and carefully.

- **IMPORTANT** – Save these instructions for local inspector’s use.
- **IMPORTANT** – Observe all governing codes and ordinances.
- **Note to Installer** – Be sure to leave these instructions with the Consumer.
- **Note to Consumer** – Keep these instructions for future reference.
- **Skill level** – Installation of this appliance requires basic mechanical skills.
- **Completion time** – Approximately 1 hour
- We recommend that two people install this product.
- Proper installation is the responsibility of the installer.
- Product failure due to improper installation is not covered under the Warranty.
- You **MUST** use all supplied parts and use proper installation procedures as described in these instructions when installing this air conditioner.

ELECTRICAL REQUIREMENTS (cont)

Power cord includes a current interrupter device. A test and reset button is provided on the plug case. The device should be tested on a periodic basis by first pressing the **TEST** button and then the **RESET** button while plugged into the outlet. If the **TEST** button does not trip or if the **RESET** button will not stay engaged, discontinue use of the air conditioner and contact a qualified service technician.

ELECTRICAL REQUIREMENTS



These models require a 115/120-volt AC, 60-Hz grounded outlet protected with a 15-amp time-delay fuse or circuit breaker.

The 3-prong grounding plug minimizes the possibility of electric shock hazard. If the wall outlet you plan to use is only a 2-prong outlet, it is your responsibility to have it replaced with a properly grounded 3-prong wall outlet.

⚠ CAUTION

Do not, under any circumstances, cut or remove the third (ground) prong from the power cord.

Do not change the plug on the power cord of this air conditioner.

Aluminum house wiring may present special problems—consult a qualified electrician.

TOOLS YOU WILL NEED

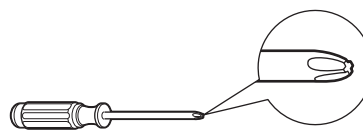

Phillips head screwdriver

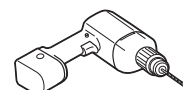

Drill and 1/8" drill bit



Pencil

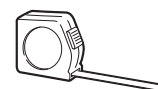

Ruler or tape measure



Level

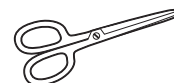

Scissors or knife

Installation Instructions

PARTS INCLUDED (Appearance may vary)

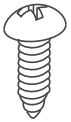
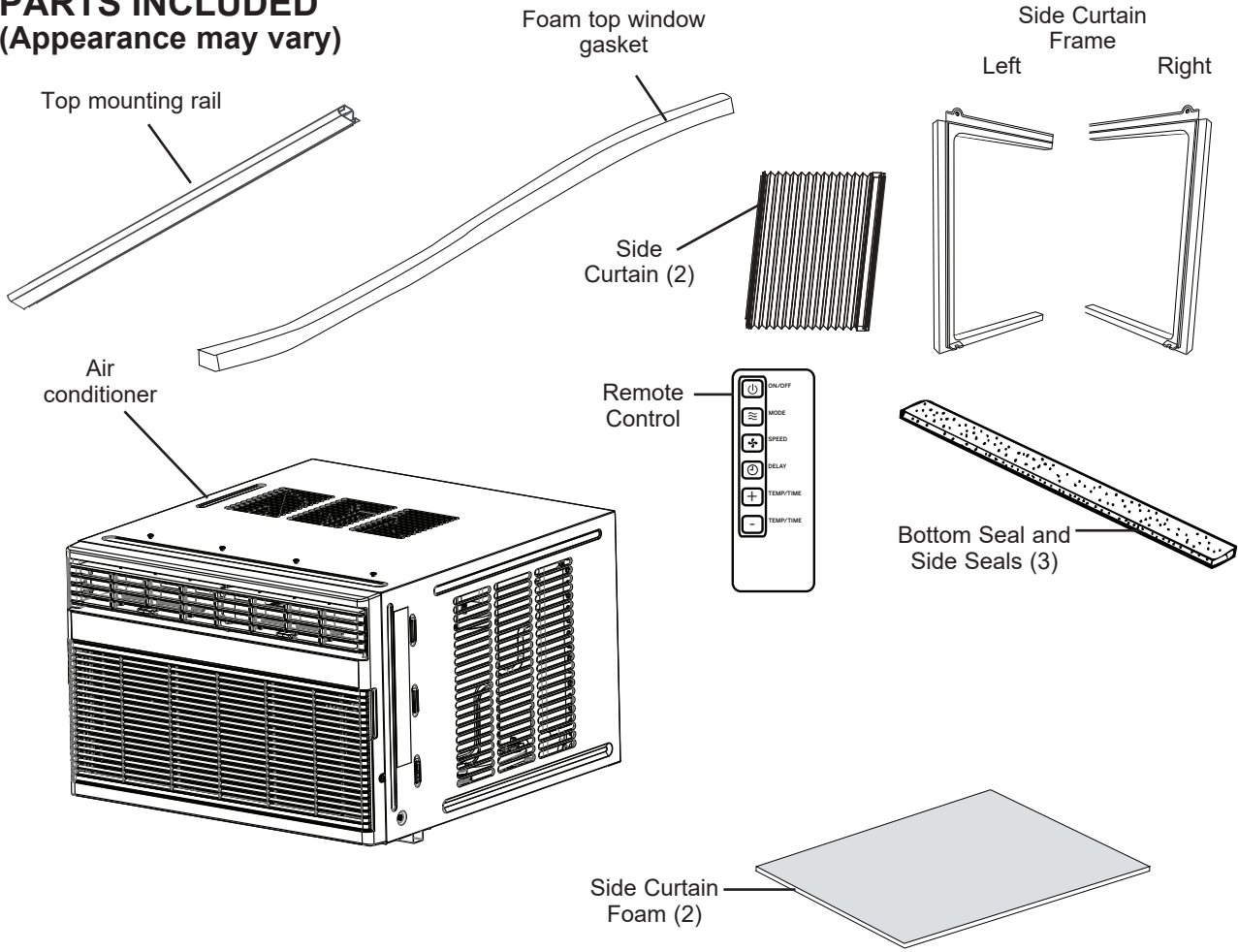

AHY10 / AHY12 / AHY14: Type A (4)
AHY08: Type A (3)

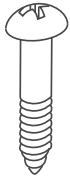

Type B (9)

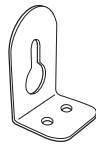

Side Brackets (2)



Window locking bracket (1)

Installation Instructions

1. WINDOW REQUIREMENTS

- These instructions are for a standard double-hung window. You will need to modify them for other types of windows.
- The air conditioner can be installed without the side curtain panels if needed to fit in a narrow window. See the window opening dimensions.
- All supporting parts must be secured to firm wood, masonry or metal.
- The electrical outlet must be within reach of the power cord.
- Follow the dimensions in the table and illustration for your model.

Models	A	B
AHY08	13 3/8" min	24 1/2"-36"
AHY10/AHY12	14 9/16" min	25" - 36 5/8"
AHY14	15 5/8"	26 1/8" - 37 3/4"

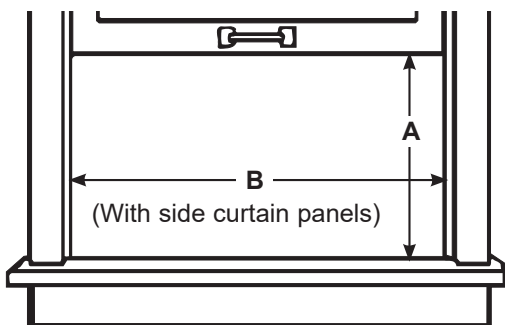

2. STORM WINDOW REQUIREMENTS

A storm window frame will not allow the air conditioner to tilt toward the outside, and will keep it from draining properly. To adjust for this, attach a piece of wood to the sill.

WOOD PIECES

WIDTH: 2"

LENGTH: Long enough to fit inside the window frame.

THICKNESS: To determine the thickness, place a piece of wood on the sill to make it 1/2" higher than the top of the storm window frame or the vinyl frame.

Attach securely with nails or screws provided by the installer.

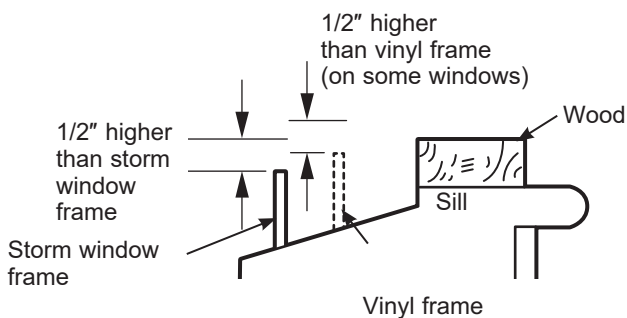

3. PREPARE THE AIR CONDITIONER

- A.** Install the top mounting rail with 4 Type A screws (AHY10 / AHY12 / AHY14) or 3 Type A screws (AHY08) from the outside of the case.

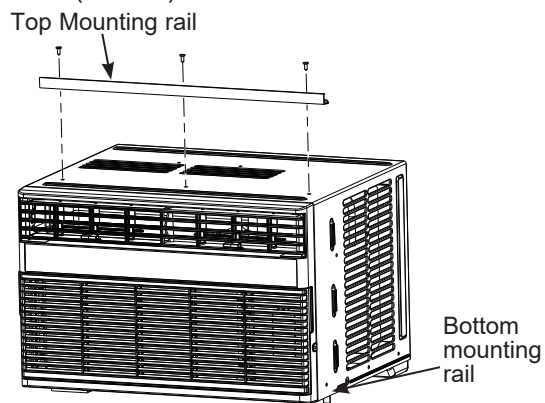

- B.** Apply the weather seals provided to the bottom, top and sides of the window to the seal around the perimeter of the air conditioner.

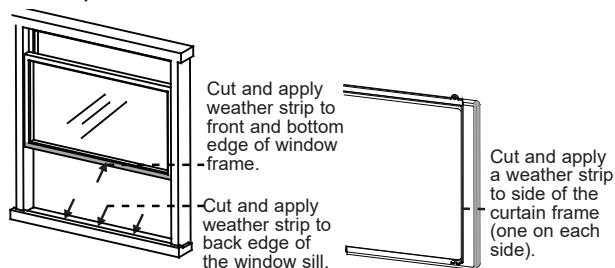

- C.** Slide the side curtain panels into the side panel rails.

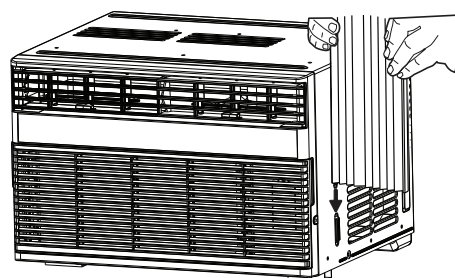

- D.** Slide left and right side curtain frames into top and bottom rails. Make sure that side curtains snap into side of the frames.

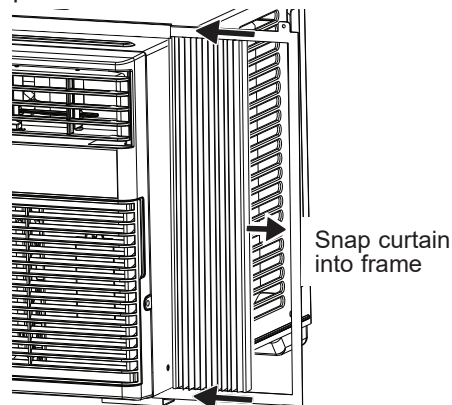

Installation Instructions

4. INSTALL THE AIR CONDITIONER IN THE WINDOW

- A. Mark the center of the window. Set the air conditioner in the window so that it is centered. Place the air conditioner so that front edge of the bottom mounting rail is against the back edge of the sill.
- B. Bring the window down so that the front edge of the top mounting is in front of the window. Make sure that the air conditioner is level or tilting slightly to the outside.

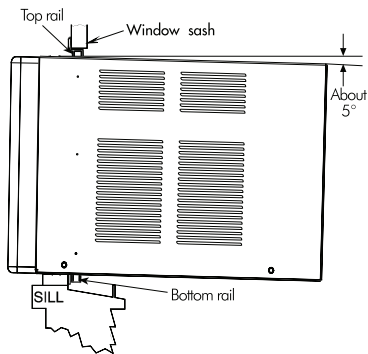

- C. Extend the curtain panels until they fill the window. Mark the location of the holes in each corner. Use the drill and 1/8" drill bit to drill pilot holes. Use 4 type B screws to secure the side panels in place.

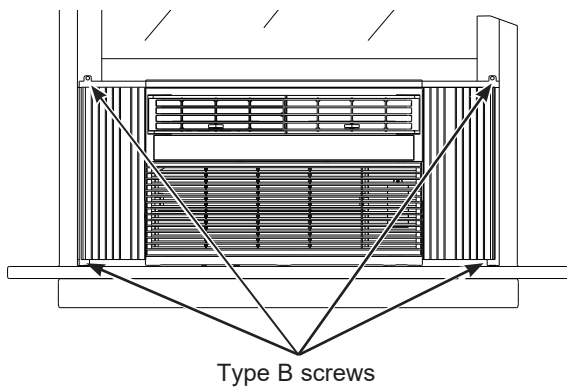

5. SECURE AIR CONDITIONER

- A. Loosen the screw on the right hand side of the air conditioner near the bottom.
- B. Slide a side bracket over the screw so that the bracket is resting on the window sill. Tighten the screw.

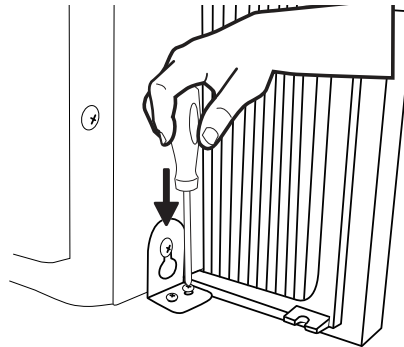

- C. Use a 1/8" drill bit to drill a starter hole into the window sill through the holes in the side bracket. Use 4 type B screws to attach the side bracket to the window sill.
- D. Repeat the side bracket installation on the left side.
- E. Measure and cut adhesive foam backed sheet. Apply over side curtain and frame.

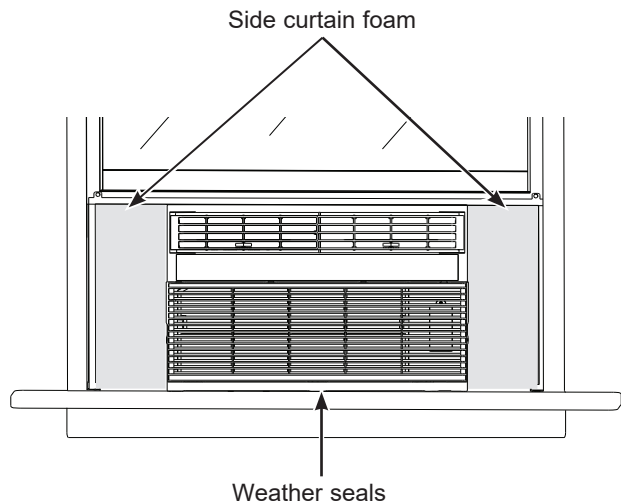

Installation Instructions

6. INSTALL WINDOW LOCK BRACKET AND FOAM TOP WINDOW GASKET

Use Type B Screw to install the window lock bracket on top of the bottom window.

A. CAUTION

To prevent broken glass or damage to windows, on vinyl or other similarly constructed windows, attach the window locking bracket to the window side jamb with one Type B screw.

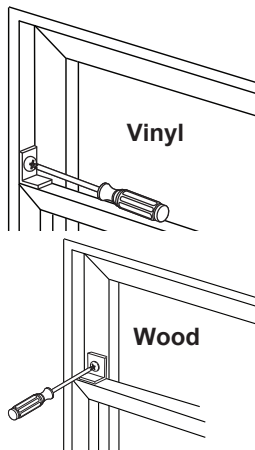

B. Cut the foam top window gasket to the window width.

C. Stuff the foam between the glass and the window to prevent air and insects from getting into the room.

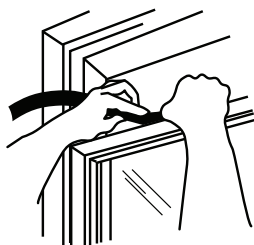

NOTE: If the gasket supplied does not fit your window, obtain appropriate material locally to provide a proper installation seal.

Troubleshooting Tips... Before you call for service

Save time and money! Review the charts on the following pages first and you may not need to call for service.

Problem	Possible Cause	What To Do
Air conditioner does not start.	The unit is unplugged.	Make sure the air conditioner plug is pushed completely into the outlet.
	The fuse is blown/circuit breaker is tripped.	Check the house fuse/circuit breaker box and replace the fuse or reset the breaker.
	Power Failure.	The unit will automatically restart in the setting last used after the power is restored. There is a protective time delay (approximately 3 minutes) to prevent tripping of the compressor overload. For this reason, the unit may not start normal cooling for 3 minutes after it is turned back on.
	The current interrupter device is tripped.	Press RESET button located on the power cord plug. If the RESET button will not stay engaged, discontinue use of the air conditioner and contact a qualified service technician.
Air conditioner does not cool as it should.	Indoor airflow is restricted.	Make sure there are not curtains, blinds or furniture blocking the front of the air conditioner.
	The temp control may not be set properly.	Turn the temperature control to a higher number.
	The air filter is dirty.	Clean the filter at least every 30 days. See Care and Cleaning section.
	The room may have been hot.	When the air conditioner is first turned on, you need to allow time for the room to cool down.
	Cold air is escaping.	Check for open furnace registers and cold air returns.
	Cooling coils have iced up.	See "Air conditioner freezing up" below.
Air conditioner freezing up	Ice blocks the air flow and stops the air conditioner from cooling the room.	Set the mode control to High Fan or High Cool with the temperature setting as high as it can be set.
Water drips outside	Hot, humid weather.	This is normal.
Water drips inside	The air conditioner is not tilted to the outside.	For proper disposal, make sure the air conditioner slants slightly from the case front to the rear.
Water collects in base pan	Moisture removed from air and drain into base pan.	This is normal for a short period in areas with little humidity; normal for a longer period in very humid areas.

Normal Operating Sounds

- You may hear a pinging noise caused by water being picked up and thrown against the condenser on rainy days or when the humidity is high. This design feature helps remove moisture and improve efficiency.
- You may hear the thermostat click when the compressor cycles on and off.
- Water will collect in the base pan during high humidity or on rainy days. The water may overflow and drip from the outdoor side of the unit.
- The fan may run even when the compressor does not.
- Water droplets being thrown against the outside coils can make a pinging noise. This helps cool the condenser. You can reduce this noise by removing the subbase water plug.

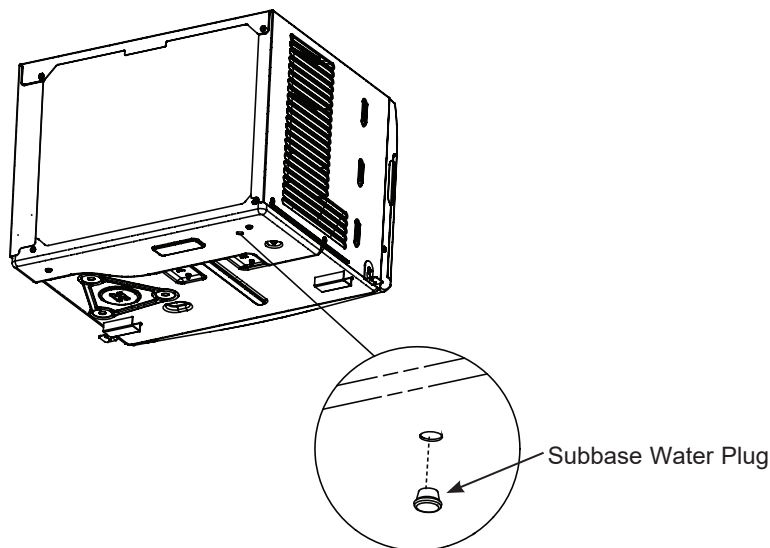

To ensure maximum efficiency it is recommended to check to ensure the rubber drain plug is properly inserted. This plug may be removed during operation to minimize water in the back of the unit; however, removing it will lower the efficiency of your unit.

NOTE: Do not drill hole in the base pan.

WiFi Setup

GE Appliances WiFi Connect (for customers in the United States)

GE Appliances WiFi Connect Enabled*. If your Air Conditioner (AC) has a Connected Appliance Information label located on the outside as shown below, your AC is **GE Appliances WiFi Connect Enabled**. A WiFi communication card is built into the product allowing it to communicate with your smart phone for remote monitoring, control and notifications. Please visit www.GEAppliances.com/connect to learn more about connected appliance features, and to learn what connected appliance apps will work with your smart phone.

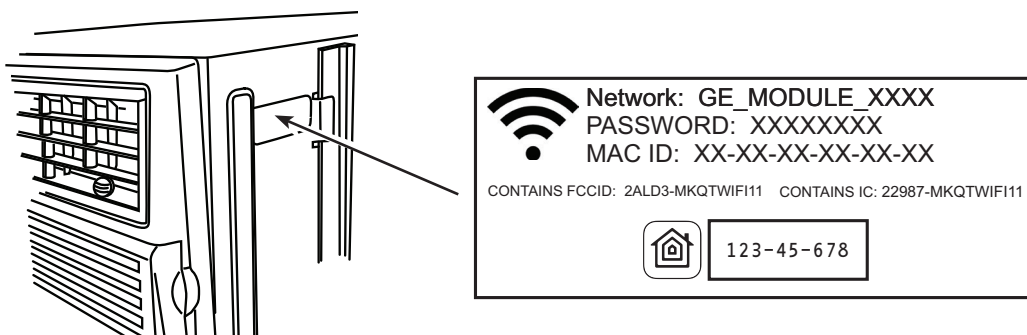

WiFi Connectivity: For assistance with the appliance or the **ConnectPlus** network connectivity (for models that are WiFi enabled or WiFi optional), please call **1-800-220-6899**.

WiFi Setup

How it Works

Download the GE Appliances App



Use the app to connect your room air conditioner to WiFi



Once connected, use the app to turn down your air conditioner as you leave work.

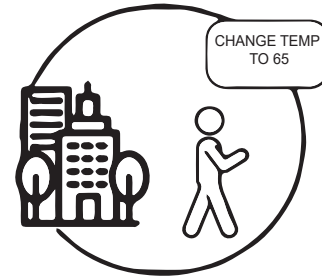

Getting Started

To connect your room air conditioner, you'll need the GE Appliances App. The app will walk you through the connection process. Download the app from iTunes or Google Play.



All connected appliance data is held in strict accordance with the GE Appliances Connected Data Privacy Policy. Visit geappliances.com/privacy/privacy_policy_connected to view this policy.

Questions about WiFi Connect

Get answers you need about setting up WiFi appliances and connecting to your home network in our support articles.

Visit products.geappliances.com/appliance/gea-support-search-content to view wifi connect room air conditioner support articles.

REGULATORY INFORMATION

FCC/IC Compliance Statement:

This device complies with Part 15 of the FCC Rules. Operation is subject to the following two conditions:

1. This device may not cause harmful interference.
2. This device must accept any interference received, including interference that may cause undesired operation.

This equipment has been tested and found to comply with the limits for a Class B digital device, pursuant to Part 15 of the FCC Rules. These limits are designed to provide reasonable protection against harmful interference in a residential installation. This equipment generates uses and can radiate radio frequency energy and, if not installed and used in accordance with the instructions, may cause harmful interference to radio communications. However, there is no guarantee that interference will not occur in a particular installation. If this equipment does cause harmful interference to radio or television reception, which can be determined by turning the equipment off and on, the user is encouraged to try to correct the interference by one or more of the following measures:

- Reorient or relocate the receiving antenna.
- Increase the separation between the equipment and receiver.
- Connect the equipment into an outlet on a circuit different from that to which the receiver is connected.
- Consult the dealer or an experienced radio/television technician for help.

Labelling: Changes or modifications to this unit not expressly approved by the manufacturer could void the user's authority to operate the equipment.

*Select Models Only

This product has Wi-Fi capability and requires Internet connectivity and a wireless router to enable interconnection with an Energy Management System, and/or with other external devices, systems or applications.

Use of the Works with Apple HomeKit™ logo means that an electronic accessory has been designed to connect specifically to iPod touch®, iPhone®, or iPad®, respectively, and has been certified by the developer to meet Apple® performance standards. Apple is not responsible for the operation of this device or its compliance with safety and regulatory standards.

Notes

GE Appliances Air Conditioner Limited Warranty

LIMITED WARRANTY

For The Period Of:	Will Replace:
One Year From the date of the original purchase	Replacement, repair, or refund of the original retail price for any product which fails due to a defect in materials or workmanship. If the unit is exchanged, the replacement unit is warranted for the remainder of your product's original one-year warranty period. GE Appliances will, at its sole discretion, replace the product with a product of the same or comparable functionality and quality or refund the original retail price.

In Order to Make a Warranty Claim During Your Retailer's Allowable Return Period:

- Properly pack your unit. We recommend using the original carton and packing materials.
- Return the product to the retail location where it was purchased.
- Include in the package a copy of the sales receipt or other evidence of date of original purchase. Also print your name and address and a description of the defect.

In Order to Make a Warranty Claim During the Remainder of the One-Year Warranty:

- Locate your original sales receipt and make a note of your model and serial number.
- Call 1-800-GE-CARES (1-800-432-2737) to initiate the product replacement process.
- You will be asked to provide your name, address, date of purchase, model and serial number.
- GE Appliances will arrange for a carton to be sent to your home to recover the product.
- Please return all requested materials (postage pre-paid) in the carton provided. Please include a description of the defect.
- You should receive your replacement product or refund within 7 to 10 business days after your package is received.

What Will Not Cover:

- Customer instruction. This owner's manual provides information regarding operating instructions and user controls.
- Improper installation. If you have an installation problem, or if the air conditioner is of improper capacity, contact your dealer or installer. You are responsible for providing adequate electrical connecting facilities.
- Failure of the product resulting from modifications to the product or due to unreasonable use including failure to provide reasonable and necessary maintenance.
- Replacement of house fuses or resetting of circuit breakers.
- Failure due to corrosion on models not corrosion-protected.
- Damage to the product caused by improper power supply voltage, accident, fire, floods or acts of God.
- Incidental or consequential damage caused by possible defects with this air conditioner.
- Damage caused after delivery.

EXCLUSION OF IMPLIED WARRANTIES - Your sole and exclusive remedy is product repair as provided in this Limited Warranty. Any implied warranties, including the implied warranties of merchantability or fitness for a particular purpose, are limited to one year or the shortest period allowed by law.

This limited warranty is extended to the original purchaser and any succeeding owner for products purchased for home use within the USA. If the product is located in an area where service by a GE Appliances Authorized Servicer is not available, you may be responsible for a trip charge or you may be required to bring the product to an Authorized GE Appliances Service location for service. In Alaska, the limited warranty excludes the cost of shipping or service calls to your home.

Some states do not allow the exclusion or limitation of incidental or consequential damages. This limited warranty gives you specific legal rights, and you may also have other rights which vary from state to state. To know what your legal rights are, consult your local or state consumer affairs office or your state's Attorney General.

Warrantor:
GE Appliances, a Haier company
Louisville, KY 40225

Staple your receipt here. Proof of the original purchase date is needed to obtain service under the warranty.

Consumer Support

GE Appliances Website

Have a question or need assistance with your appliance? Try the GE Appliances Website 24 hours a day, any day of the year! You can also shop for more great GE Appliances products and take advantage of all our on-line support services designed for your convenience. **GEAppliances.com**

Register Your Appliance

Register your new appliance on-line at your convenience! Timely product registration will allow for enhanced communication and prompt service under the terms of your warranty, should the need arise. You may also mail in the pre-printed registration card included in the packing material. **GEAppliances.com/register**

Parts and Accessories

Individuals qualified to service their own appliances can have parts or accessories sent directly to their homes (VISA, MasterCard and Discover cards are accepted). Order on-line today 24 hours every day. **GEApplianceparts.com** or by phone at 877.959.8688 during normal business hours.

Instructions contained in this manual cover procedures to be performed by any user. Other servicing generally should be referred to qualified service personnel. Caution must be exercised, since improper servicing may cause unsafe operation.

Contact Us

If you are not satisfied with the service you receive from GE Appliances, contact us on our Website with all the details including your phone number, or write to:

General Manager, Customer Relations | GE Appliances, Appliance Park | Louisville, KY 40225

GEAppliances.com/ge/service-and-support/contact.htm