



Top Freezer REFRIGERATORS

SAFETY INFORMATION3

USING THE REFRIGERATOR

Controls5

Storage Drawers.....5

Ice Service.....6

CARE AND CLEANING7

Cleaning the Outside.....7

Cleaning the Inside7

Replacing the LED Light.....8

Preparing for Vacation8

Preparing to Move8

INSTALLATION INSTRUCTIONS

Preparing to Install the Refrigerator.....9

Features.....10

Reversing the Door Swing 11

TROUBLESHOOTING

Normal Operating Sounds14

Troubleshooting Tips.....15

LIMITED WARRANTY17

ACCESSORIES.....18

CONSUMER SUPPORT 20

OWNER'S MANUAL & INSTALLATION INSTRUCTIONS

GPE12

**ENGLISH/FRANÇAIS/
ESPAÑOL**

Write the model and serial numbers here:

Model # _____

Serial # _____

Find these numbers on a label inside the fresh food compartment.

THANK YOU FOR MAKING GE APPLIANCES A PART OF YOUR HOME.

Whether you grew up with GE Appliances, or this is your first, we're happy to have you in the family.

We take pride in the craftsmanship, innovation and design that goes into every GE Appliances product, and we think you will too. Among other things, registration of your appliance ensures that we can deliver important product information and warranty details when you need them.

Register your GE appliance now online. Helpful websites and phone numbers are available in the Consumer Support section of this Owner's Manual. You may also mail in the pre-printed registration card included in the packing material.



IMPORTANT SAFETY INFORMATION

READ ALL INSTRUCTIONS BEFORE USING THE APPLIANCE

⚠ WARNING To reduce the risk of fire, explosion, electric shock, or injury when using your refrigerator, follow these basic safety precautions:

- This refrigerator must be properly installed and located in accordance with the Installation Instructions before it is used.
- Unplug the refrigerator before making repairs, replacing a light bulb, or cleaning.
NOTE: Power to the refrigerator cannot be disconnected by any setting on the control panel.
NOTE: Repairs must be performed by a qualified Service Professional.
- Replace all parts and panels before operating.
- Do not store or use gasoline or other flammable vapors and liquids in the vicinity of this or any other appliance.
- Do not store explosive substances such as aerosol cans with a flammable propellant in this appliance.
- Do not use an extension cord.
- To prevent suffocation and entrapment hazards to children, remove the fresh food and freezer doors from any refrigerator before disposing of it or discontinuing its use.
- To avoid serious injury or death, children should not stand on, or play in or with the appliance.
- Children and persons with reduced physical, sensory or mental capabilities or lack of experience and knowledge can use this appliance only if they are supervised or have been given instructions on safe use and understand the hazards involved.
- This appliance is intended to be used in household and similar applications such as: staff kitchen areas in shops, offices and other working environments; farm houses; by clients in hotels, motels, bed & breakfast and other residential environments; catering and similar non-retail applications.
- Do not apply harsh cleaners to the refrigerator. Certain cleaners will damage plastic which may cause parts such as the door or door handles to detach unexpectedly. See the Care and Cleaning section for detailed instructions.

⚠ CAUTION To reduce the risk of injury when using your refrigerator, follow these basic safety precautions.

- Do not clean glass shelves or covers with warm water when they are cold. Glass shelves and covers may break if exposed to sudden temperature changes or impact, such as bumping or dropping. Tempered glass is designed to shatter into many small pieces if it breaks.
- Keep fingers out of the “pinch point” areas; clearances between the doors and between the doors and cabinet are necessarily small. Be careful closing doors when children are in the area.
- Do not touch the cold surfaces in the freezer compartment when hands are damp or wet, skin may stick to these extremely cold surfaces.
- Do not refreeze frozen foods which have thawed completely.
- In refrigerators with automatic icemakers, avoid contact with the moving parts of the ejector mechanism, or with the heating element that releases the cubes. Do not place fingers or hands on the automatic ice making mechanism while the refrigerator is plugged in.

⚠ WARNING  **EXPLOSION HAZARD Flammable Refrigerant**

This appliance contains isobutane refrigerant, R600a, a natural gas with high environmental compatibility. However, it is also combustible. Adhere to the warnings below to reduce the risk of injury or property damage.

1. When handling, installing and operating the appliance, care should be taken to avoid damage to the refrigerant tubing.
2. Service shall only be performed by authorized service personnel. Use only manufacturer-authorized service parts.
3. Dispose of refrigerator in accordance with Federal and Local Regulations. Flammable refrigerant and insulation material used require special disposal procedures. Contact your local authorities for the environmentally safe disposal of your refrigerator.
4. Keep ventilation openings in the appliance enclosures or in the built-in structure clear of obstruction.
5. Do not use mechanical devices or other means to accelerate the defrosting process.
6. Do not damage refrigerant circuit.
7. Do not use electrical appliances inside the food storage compartment of the appliance.

READ AND SAVE THESE INSTRUCTIONS

IMPORTANT SAFETY INFORMATION

READ ALL INSTRUCTIONS BEFORE USING THE APPLIANCE

INSTALLATION

▲ WARNING EXPLOSION HAZARD

Keep flammable materials and vapors, such as gasoline, away from refrigerator. Failure to do so can result in fire, explosion, or death.

CONNECTING ELECTRICITY

▲ WARNING ELECTRICAL SHOCK HAZARD

Plug into a grounded 3-prong outlet
Do not remove the ground prong
Do not use an adapter
Do not use an extension cord.
Failure to follow these instructions can result in death, fire, or electrical shock.

Do not, under any circumstances, cut or remove the third (ground) prong from the power cord. For personal safety, this appliance must be properly grounded.

The power cord of this appliance is equipped with a 3-prong (grounding) plug which mates with a standard 3-prong (grounding) wall outlet to minimize the possibility of electric shock hazard from this appliance.

Have the wall outlet and circuit checked by a qualified electrician to make sure the outlet is properly grounded.

Where a standard 2-prong wall outlet is encountered, it is your personal responsibility and obligation to have it replaced with a properly grounded 3-prong wall outlet. Do not use an adapter.

The refrigerator should always be plugged into its own individual electrical outlet which has a voltage rating that matches the rating plate.

A 115 Volt AC, 60 Hz, 15- or 20-amp fused, grounded electrical supply is required. This provides the best performance and also prevents overloading house wiring circuits which could cause a fire hazard from overheated wires.

Never unplug your refrigerator by pulling on the power cord. Always grip plug firmly and pull straight out from the outlet.

Immediately discontinue use of a damaged supply cord. If the supply cord is damaged, it must be replaced by a qualified service professional with an authorized service part from the manufacturer.

When moving the refrigerator away from the wall, be careful not to roll over or damage the power cord.

PROPER DISPOSAL OF YOUR OLD REFRIGERATOR

▲ WARNING SUFFOCATION AND ENTRAPMENT HAZARD

Failure to follow these disposal instructions can result in death or serious injury

IMPORTANT: Child entrapment and suffocation are not problems of the past. Junked or abandoned refrigerators or freezers are still dangerous even if they will sit for “just a few days.” If you are getting rid of your old refrigerator or freezer, please follow the instructions below to help prevent accidents.

Before You Throw Away Your Old Appliance

- Take off the fresh food and freezer doors.
- Leave the shelves in place so that children may not easily climb inside.

Refrigerant and Foam Disposal:

Dispose of appliance in accordance with Federal and Local Regulations. Flammable refrigerant and insulation material used requires special disposal procedures. Contact your local authorities for the environmentally safe disposal of your appliance.

READ AND SAVE THESE INSTRUCTIONS

Controls

The temperature control is located in the fresh food compartment. Initially set the control to the recommended setting. Allow 24 hours for temperature to stabilize.

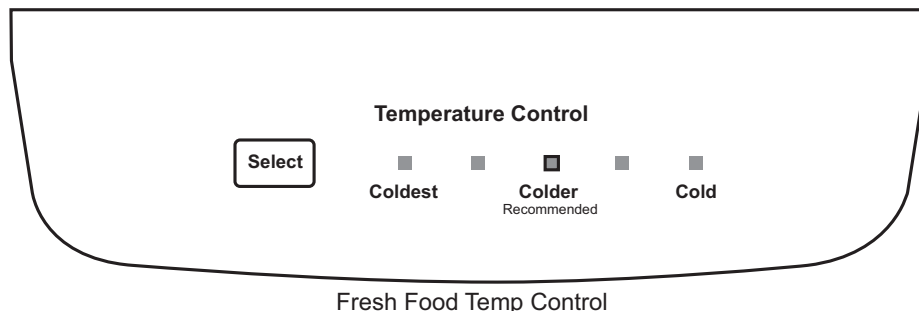

Control Settings

The control in the fresh food compartment should be adjusted one increment at a time. Allow 12 hours after each adjustment for the compartment to reach the temperature you have set. The freezer compartment will be colder when the fresh food compartment temperature is lower.

Control settings will vary based on personal preferences, usage and operating conditions and may require more than one adjustment. Factors that affect temperature include the amount of food in the fresh food and freezer compartments, frequency of door opening, and temperature of food when placed in either compartment.

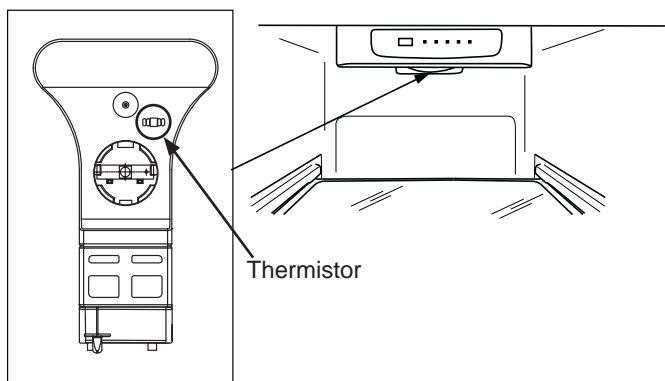

Thermistor

The thermistor located at the bottom of the fresh food control housing is one of the key elements for temperature control. Keep all items away from blocking the thermistor as this will reduce the sensitivity of the thermistor and cause temperature issues. Food may freeze or become too warm depending on the compressor cycle if the air flow is blocked.

Storage Drawers

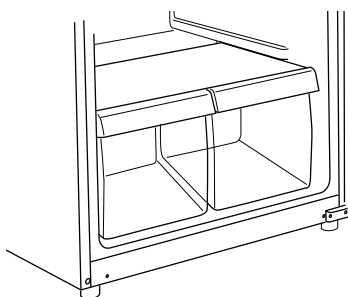

Fruit and Vegetable Drawers

These storage drawers provide space to store fruits, vegetables and meats.

To remove and replace the drawers and the cover above them, the door must be fully opened. In some installations, the refrigerator may have to be moved away from the wall for the door to be fully opened.

Ice Service

Ice Trays

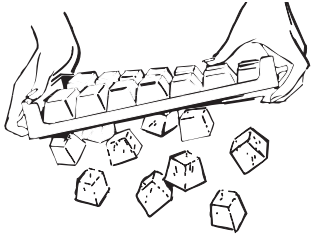

To make ice, fill the ice tray with water and set it on a level surface in the freezer compartment. Ice cubes will form in a few hours.

To release ice cubes, turn the tray upside down, hold it over a container and twist both ends.

For only one or two ice cubes, leave the tray right-side up, twist both ends slightly and remove as many cubes as you want.

Wash ice trays in lukewarm water only—do not put them in an automatic dishwasher.

Care And Cleaning

Cleaning the Outside

Directions for Cleaning Outside Surfaces, Door Handles, and Trim

DO USE	DO NOT USE
Soft, clean cloth or sponge	Abrasive cloths, scrubbing sponges, scouring or steel wool pads
Mild detergent mixed with warm water Approved stainless steel cleaners; Visit the Café Appliances parts store for approved stainless steel cleaners: geapplianceparts.com or call 877.959.8688 Cleaners with oxalic acid such as Bar Keepers Friend Soft Cleanser™ can be used to remove surface rust, tarnish and small blemishes on stainless steel surfaces only.	Abrasive powders or sprays Window Sprays or Ammonia Citrus or plant oil-based cleaners Acidic or vinegar-based cleaners Oven cleaners Cleaners containing acetone (propanone) Any cleaner with WARNING about plastic contact

NOTE: DO NOT allow stainless steel cleaner to come in contact with any plastic parts such as trim pieces, handle hardware and liners. If unintentional contact of cleaners with plastic parts does occur, clean plastic part with a sponge and mild detergent mixed with warm water.

Cleaning the Inside

To help prevent odors, leave an open box of baking soda in the fresh food and freezer compartments.

Unplug the refrigerator before cleaning.

If this is not practical, wring excess moisture out of sponge or cloth when cleaning around switches, lights or controls.

Use warm water and baking soda solution—about a tablespoon (15 ml) of baking soda to a quart (1 liter) of water. This both cleans and neutralizes odors. Rinse and wipe dry.

Other parts of the refrigerator—including door gaskets, fruit and vegetable drawers, and all plastic parts—can be cleaned the same way.

After cleaning the door gaskets, apply a thin layer of petroleum jelly to the door gaskets at the hinge side. This helps keep the gaskets from sticking and bending out of shape. Do not use cleansing powders or other abrasive cleaners.

⚠ CAUTION

Do not clean glass shelves or covers with warm water when they are cold. Glass shelves and covers may break if exposed to sudden temperature changes or impact such as bumping or dropping. Tempered glass is designed to shatter into many small pieces if it breaks.

Do not wash any plastic refrigerator parts in the dishwasher.

Care and Cleaning

Replacing the LED Light

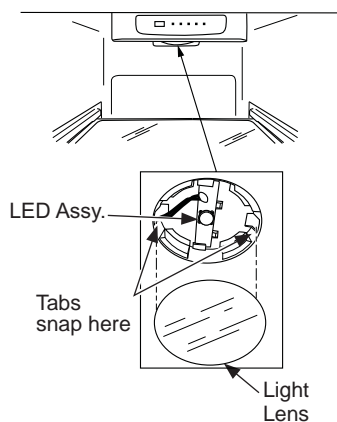

The LED light is located behind a light lens in the ceiling of the refrigerator section.

1. Remove the top shelf (if necessary).
2. Drop down the control housing assembly.
3. Remove the light lens by using a flat head screwdriver to push one of tabs down. The lens snaps in and out.
4. Slide the LED assembly from the mounting slot.
5. Gently pull the leads out and disconnect from the control housing assembly.
6. Replace with new LED assembly and slide assembly back into the mounting slot.
7. Replace the light lens by snapping it into place.
8. To order the LED assembly, please call GE Appliances at 800.GE.CARES (800.492.2737) during normal business hours.

Preparing for Vacation

For long vacations or absences, remove food and unplug the refrigerator. Clean the interior with a baking soda solution of one tablespoon (15 ml) of baking soda to one quart (1 liter) of water. Leave the doors open.

Preparing to Move

Remove food and unplug the refrigerator. Secure all loose items such as shelves and drawers by taping them securely in place to prevent damage.

Be sure the refrigerator stays in an upright position during moving.

Installation Instructions Model GPE12

If you have questions, call 800.GE.CARES or visit our Website at: GEAppliances.com.
In Canada, call 1.800.561.3344 or Visit our Website at: geappliances.ca

BEFORE YOU BEGIN

Read these instructions completely and carefully.

- **IMPORTANT** – Save these instructions for local inspector's use.
- **IMPORTANT** – Observe all governing codes and ordinances.
- **Note to Installer** – Be sure to leave these instructions with the Consumer.
- **Note to Consumer** – Keep these instructions for future reference.
- **Skill level** – Installation of this appliance requires basic mechanical skills.
- **Completion time**—Refrigerator Installation
15 minutes
Reversing the Door Swing
1 hour
- Proper installation is the responsibility of the installer.
- Product failure due to improper installation is not covered under the Warranty.

REFRIGERATOR LOCATION

- Do not install the refrigerator where the temperature will go below 55°F (12.7°C) because it will not run often enough to maintain proper temperatures.
- Do not install the refrigerator where the temperature will go above 100°F (37°C) because it will not perform properly.
- Do not install the refrigerator in a location exposed to water (rain, etc.) or direct sunlight.
- Install it on a floor strong enough to support it fully loaded.

CLEARANCES

Allow the following clearances for ease of installation, proper air circulation and plumbing and electrical connections.

Sides 1" (25.4 mm)
Top 4" (101.6 mm)
Back 0" (0 mm)

UNPACKING YOUR REFRIGERATOR

- Remove tape and any labels (except for the rating label) from your refrigerator. Tape or glue residue can also be removed by rubbing a small amount of liquid dish soap over the adhesive with your fingers. Wipe with warm water and dry.
- Do not use sharp instruments, rubbing alcohol, flammable fluids, or abrasive cleaners to remove tape or glue. These products can damage the surface of your refrigerator.
- When moving the refrigerator, do not tilt the refrigerator beyond 45° from upright position.

LEVELING LEGS

Adjustable legs at the front corners of the refrigerator should be set so the refrigerator is firmly positioned on the floor, and the front is raised just enough that the door closes easily when opened about halfway.

To adjust the leveling legs, turn the legs **clockwise** to raise the refrigerator, **counterclockwise** to lower it.

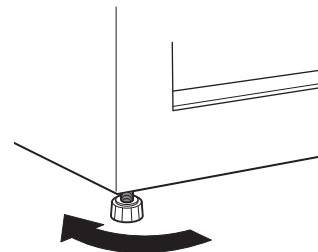

To raise the refrigerator

POWER CORD

- Plug the refrigerator power cord into its own properly grounded wall outlet with a voltage rating matching that on the refrigerator rating plate.
- Do not use an extension cord.
- Read all safety precautions on pages 3 and 4.

Installation Instructions

REFRIGERATOR FEATURES

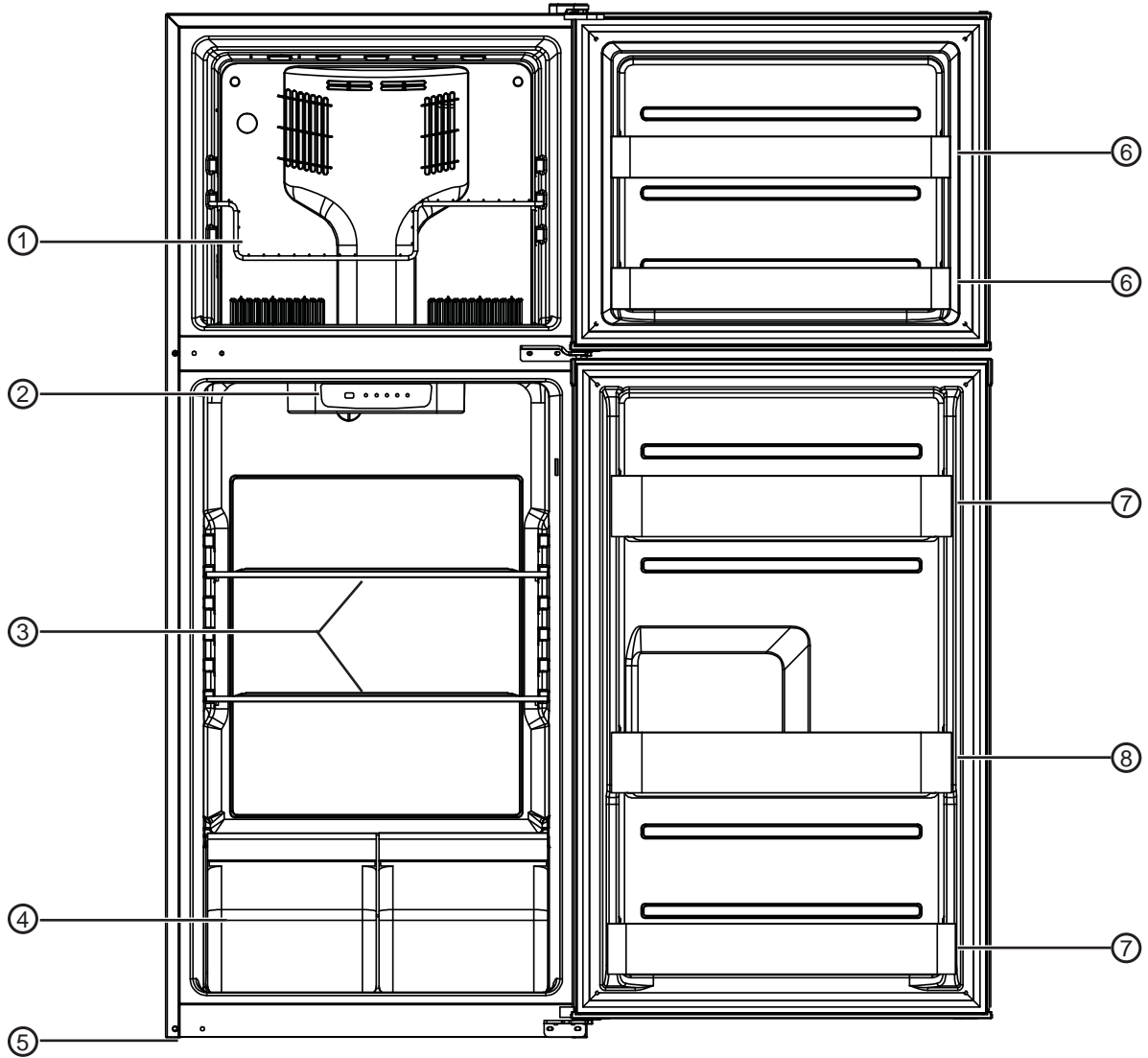

1	Freezer Shelf	5	Leveling Legs
2	Fresh Food and Freezer Controls	6	Freezer Door Bins
3	Fresh Food Shelves	7	Fresh Food Door Bin
4	Vegetable Crisper with Glass Cover and Humidity Control	8	Gallon/2-Liter Bottle Storage Door Bin

Installation Instructions

REVERSING THE DOOR SWING

⚠ WARNING Follow all steps when reversing the door swing. Failure to follow these instructions, leaving off parts, or overtightening screws, can lead to the door falling off and result in injury and property damage.

IMPORTANT NOTES

When reversing the door swing:

- Read the instructions all the way through before starting.
- Handle parts carefully to avoid scratching paint.
- Set screws down by their related parts to avoid using them in the wrong places.
- Provide a non-scratching work surface for the doors.
- It is recommended that 2 people perform this task.

IMPORTANT: Once you begin, do not move the cabinet until door-swing reversal is completed.

These instructions are for changing the hinges from the right side to the left side—if you ever want to change the hinges back to the right side, follow these same instructions and reverse all references to left and right.

Unplug the refrigerator from its electrical outlet.

Empty all door shelves.

TOOLS YOU WILL NEED

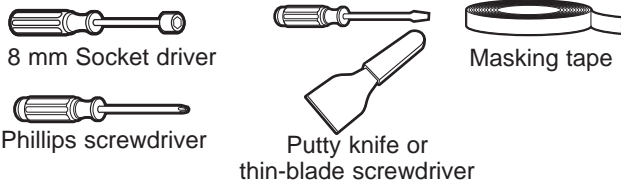

1 REMOVE THE FREEZER DOOR

Remove the hinge cover. Unscrew and remove the top hinge and shim.

Lift the freezer door up and away from the appliance.

Set the door on a non-scratching surface with the outside up.

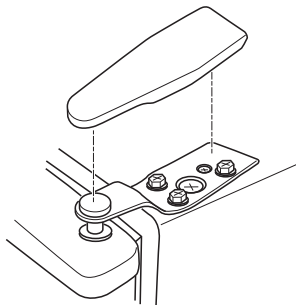

1 REMOVE THE FREEZER DOOR (CONT.)

NOTICE: Do not let door drop to the floor. Doing so could damage the door stop.

NOTE: When removing the top hinge, watch for shim between the bottom of the hinge and the top of the case that may stick to the case. Do not lose.

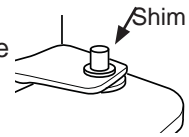

NOTE: When removing the door, watch for washer between the center hinge pin and the bottom of the freezer door that may stick to the door. Do not lose.

2 REMOVE THE FRESH FOOD DOOR

Tape the door shut with masking tape.

Remove the center hinge by removing the screws. Lift up the hinge to remove it.

NOTE: Some models have a shim between the center hinge and the case that may stick to the case. Do not lose. Also save the washers for the center hinge screws for future use.

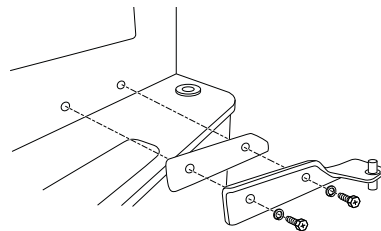

Remove the tape holding the door shut.

Lift the fresh food door up and off the bottom hinge.

Set the door outside-up on a non-scratching surface.

NOTE: When removing the door, watch for washer between the bottom hinge pin and the bottom of the fresh food door that may stick to the door. Do not lose.

NOTICE: Do not let door drop to the floor. Doing so could damage the door stop.

Installation Instructions

REVERSING THE DOOR SWING (CONT.)

3 BOTTOM HINGE

Remove the screws and bottom hinge with shim from the right side. Remove the screw covers from the left corner.

Using the left hinge included with the parts that came with your refrigerator along with the screws (and washers if applicable) removed earlier, install the left hinge onto the bottom left of your refrigerator. Make sure a shim is attached to your left hinge before installation.

Place the screw covers into the holes now vacant on the right.

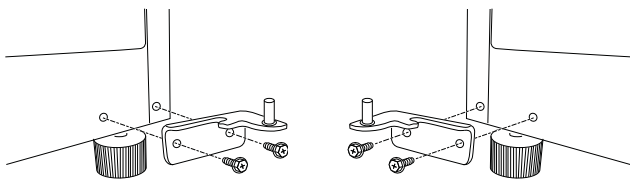

5 REHANG THE FRESH FOOD DOOR

Make sure the washer(s) are in place on the bottom hinge pin. Make sure the door is aligned horizontally and vertically. Place the fresh food door on the bottom hinge, close the door and tape it in place with masking tape.

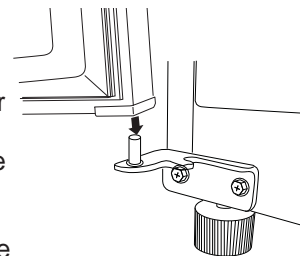

Remove the screw covers from the left edge of the door and insert it into the hole on the opposite side.

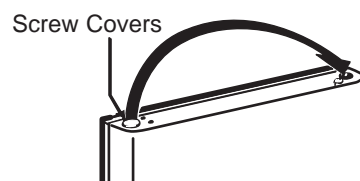

4 TRANSFER FRESH FOOD DOOR STOP TO THE LEFT

WARNING Follow all steps when reversing the door swing. Failure to follow these instructions, leaving off parts, or overtightening screws, can lead to the door falling off and result in injury and property damage.

Remove the door stop and hinge pin sleeve from the bottom of the right side of the door.

Using the left door stop included with the parts that came with your refrigerator, transfer the hinge pin sleeve to the left side and install the left door stop.

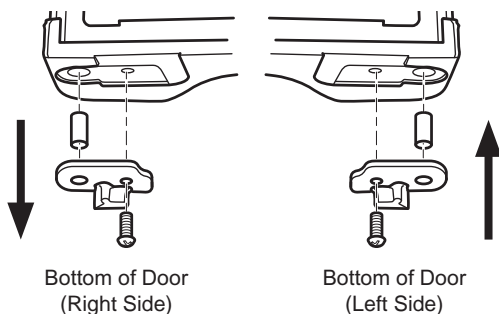

6 INSTALL CENTER HINGE ON THE LEFT

Remove the three screw covers on the left side and install two of them on the right.

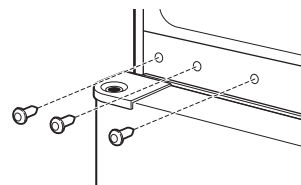

Using the middle hinge with shim and screws (and washers if applicable) removed earlier, install the middle hinge on the left side.

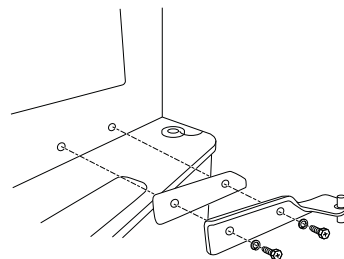

Remove the tape holding the door shut.

NOTICE: When assembled correctly, the hinge is tight against the cabinet.

ATTENTION: The screws must be properly tightened. Turn the screws until snug. Then tighten the screws a minimum of 1/2 turn using both hands.

Installation Instructions

REVERSING THE DOOR SWING (CONT.)

7 TRANSFER TOP HINGE TO THE LEFT

Using a putty knife with the edge covered with masking tape, remove the screw cover on the left. Be careful of the paint finish.

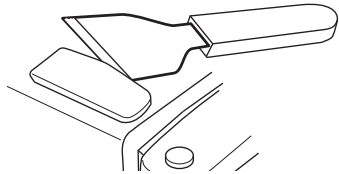

Reinstall the screw cover on the right side.

8 TRANSFER FREEZER DOOR STOP TO THE LEFT

WARNING Follow all steps when reversing the door swing. Failure to follow these instructions, leaving off parts, or overtightening screws, can lead to the door falling off and result in injury and property damage.

Remove the door stop and hinge pin sleeve from the bottom of the right side of the door.

Using the left door stop included with the parts that came with your refrigerator, transfer the hinge pin sleeve to the left side and install the left door stop.

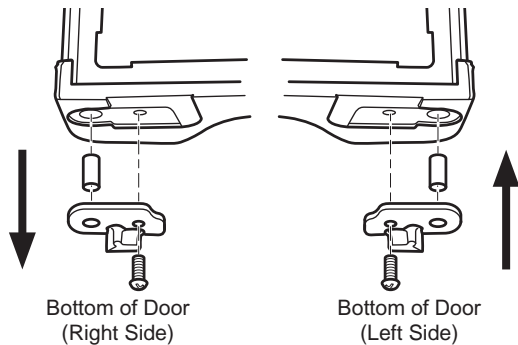

9 REHANG THE FREEZER DOOR

Transfer the screw cover on top of the door to the opposite side.

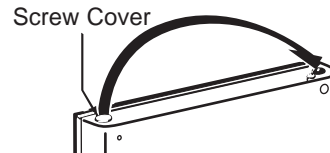

Make sure the washer (if applicable) is in place on the center hinge pin. Place the freezer door on the center hinge over the pin. Assure the door is aligned horizontally and vertically, and that the gasket seals on all sides.

Attach the top hinge removed earlier on the left side of your refrigerator and replace the hinge cover

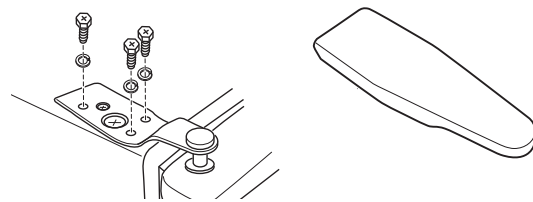

Normal Operating Sounds

Newer refrigerators sound different from older refrigerators. Modern refrigerators have more features and use newer technology.

Do you hear what I hear? These sounds are normal.

- The new high efficiency compressor may run faster and longer than your old refrigerator and you may hear a high-pitched hum or pulsating sound while it is operating.
- You may hear a whooshing sound when the doors close. This is due to pressure equalizing within the refrigerator.

HUMMM...
WHOOSH...



- You may hear the fans spinning at high speeds. This happens when the refrigerator is first plugged in, when the doors are opened frequently or when a large amount of food is added to the refrigerator or freezer compartments. The fans are helping to maintain the correct temperatures.

CLICKS, POPS, CRACKS and CHIRPS

- You may hear cracking or popping sounds when the refrigerator is first plugged in. This happens as the refrigerator cools to the correct temperature.
- The compressor may cause a clicking or chirping sound when attempting to restart (this could take up to 5 minutes).
- Expansion and contraction of cooling coils during and after defrost can cause a cracking or popping sound.
- On models with an icemaker, after an ice making cycle, you may hear the ice cubes dropping into the ice bucket.



WATER SOUNDS

- The flow of refrigerant through the freezer cooling coils may make a gurgling noise like boiling water.
- Water dropping on the defrost heater can cause a sizzling, popping or buzzing sound during the defrost cycle.
- A water dripping noise may occur during the defrost cycle as ice melts from the evaporator and flows into the drain pan.
- Closing the door may cause a gurgling sound due to pressure equalization.

Troubleshooting Tips... Before you call for service

Save time and money! Review the charts on the following pages first and you may not need to call for service. If needed, service can be scheduled by visiting us online GEAppliances.com or calling 800.GECARES 800.432.2737. In Canada visit GEAppliances.ca or call 800.561.3344.

Problem	Possible Causes	What To Do
Refrigerator does not operate	Refrigerator in defrost cycle.	Wait about 30 minutes for defrost cycle to end.
	Refrigerator is unplugged.	Push the plug completely into the outlet.
	The fuse is blown/circuit breaker is tripped.	Replace fuse or reset the breaker.
Vibration or rattling (slight vibration is normal)	Front leveling legs need adjusting.	See Leveling Legs.
Motor operates for long periods or cycles on and off frequently. (Modern refrigerators with more storage space and a larger freezer require more operating time. They start and stop often to maintain even temperatures.)	Normal when refrigerator is first plugged in.	Wait 24 hours for the refrigerator to completely cool down.
	Often occurs when large amounts of food are placed in refrigerator.	This is normal.
	Door left open.	Check to see if a package is holding door open.
	Hot weather or frequent door openings.	This is normal.
	Temperature control set at the coldest setting.	See About the control.
Fresh food or freezer compartment too warm	Temperature control not set cold enough.	See About the control.
	Warm weather or frequent door openings.	Set the temperature control one step colder. See About the control.
	Door left open.	Check to see if a package is holding door open.
Frost or ice crystals on frozen food (frost within package is normal)	Door left open.	Check to see if a package is holding door open.
	Too frequent or too long door openings.	
Ice cubes have odor/taste	Food transmitting odor/taste to ice cubes.	Wrap foods well.
	Interior of refrigerator needs cleaning.	See Care and cleaning.
Slow ice cube freezing	Door left open.	Check to see if package is holding door open.
	Temperature control not set cold enough.	See About the control.
Refrigerator has odor	Foods transmitting odor to refrigerator.	Foods with strong odors should be tightly wrapped. Keep an open box of baking soda in the refrigerator; replace every three months.
	Interior needs cleaning.	See Care and cleaning.
Moisture forms on outside of refrigerator	Not unusual during periods of high humidity.	Wipe surface dry.
Moisture collects inside (in humid weather, air carries moisture into refrigerator when doors are opened)	Too frequent or too long door openings.	

Troubleshooting Tips... Before you call for service

Problem	Possible Causes	What To Do
Interior light does not work	No power at outlet.	Replace fuse or reset the breaker.
	LED light burned out.	See Replacing the LED light
Food is freezing in the refrigerator	Food too close to the air vent at the back of the refrigerator.	Move the food away from the air vent.
	Refrigerator control is set too cold.	Move the refrigerator control to a warmer temperature setting one increment at a time. See About the controls.
	Food too close to the thermistor and blocks the air flow to the thermistor.	Move the food away from the thermistor.
Rust, tarnish, or grime on stainless steel doors	Moist environment or salt air.	Clean stainless steel with cleaners containing oxalic acid (e.g. Bar Keepers Friend Soft Cleanser) will remove rust, lime, and other tarnish. Do not wipe the refrigerator with a soiled dish cloth or wet towel. Do not use scouring pads, powdered cleaners, bleach or cleaners containing bleach because these products can scratch and ruin the brush finish of the stainless steel.

Refrigerator Limited Warranty

For US Customers, all warranty service provided by our Factory Service Centers, or an authorized Customer Care® technician. To schedule service, on-line, 24 hours a day, visit us at **GEAppliances.com**, or call 800.GE.CARES (800.432.2737). Please have serial number and model number available when calling for service.

In Canada, call 800.561.3344.

Servicing your refrigerator may require the use of the onboard data port for diagnostics. This gives a GE Appliances Factory Service technician the ability to quickly diagnose any issues with your appliance and helps improve its products by providing information on your appliance. If you do not want your appliance data to be sent to GE Appliances, please advise your technician NOT to submit the data at the time of service.

For the Period of:	GE Appliances Will Replace
One Year From the date of the original purchase	Any part of the refrigerator which fails due to a defect in materials or workmanship. During the limited one-year warranty , GE Appliances will also provide, free of charge , all labor and related service to replace the defective part.

What is Not Covered:

- Service trips to your home to teach you how to use the product.
- Improper installation, delivery or maintenance.
- Failure of the product if it is abused, misused, or used for other than the intended purpose or used commercially.
- Loss of food due to spoilage.
- Replacement of house fuses or resetting of circuit breakers.
- Damage caused after delivery.
- Replacement of the water filter cartridge, if included, due to water pressure that is outside the specified operating range or due to excessive sediment in the water supply.
- Replacement of the light bulbs, if included, or water filter cartridge, if included, other than as noted above.
- Damage to the product caused by accident, fire, floods or acts of God.
- Incidental or consequential damage caused by possible defects with this appliance.
- Product not accessible to provide required service.
- Damage caused by a non-GE Appliances Brand water filter.
- Damage to finish, such as surface rust, tarnish, or small blemishes not reported within 48 hours of delivery.
- Products which are not defective, broken, or which are working as described in the owner's manual.

EXCLUSION OF IMPLIED WARRANTIES—Your sole and exclusive remedy is product repair as provided in this Limited Warranty. Any implied warranties, including the implied warranties of merchantability or fitness for a particular purpose, are limited to one year or the shortest period allowed by law.

For US Customers: This limited warranty is extended to the original purchaser and any succeeding owner for products purchased for home use within the USA. If the product is located in an area where service by a GE Appliances Authorized Servicer is not available, you may be responsible for a trip charge or you may be required to bring the product to an Authorized GE Appliances Service location for service. In Alaska, the limited warranty excludes the cost of shipping or service calls to your home.

Some states do not allow the exclusion or limitation of incidental or consequential damages. This limited warranty gives you specific legal rights, and you may also have other rights which vary from state to state. To know what your legal rights are, consult your local or state consumer affairs office or your state's Attorney General.

Warrantor US: GE Appliances, a Haier company
Louisville, KY 40225

For Customers in Canada: This limited warranty is extended to the original purchaser and any succeeding owner for products purchased in Canada for home use within Canada. In-home warrant service will be provided in areas where it is available and deemed reasonable by Mabe to provide.

Warrantor Canada: MC Commercial, Burlington, Ontario, L7R 5B6

Staple your receipt here. Proof of the original purchase date is needed to obtain service under the warranty.

Accessories

Icemaker Accessory Kit IM4D:

An IM4D icemaker accessory kit is available at extra cost.

To order, go to GEApplianceparts.com or call 800.626.2002. In Canada call 800.661.1616. For installation, please follow instructions in the IM4D Icemaker Accessory Kit Owner's Manual.

NOTE: The step shelf in the freezer **MUST** be placed in the lowest position when the icemaker is installed.

The water valve cover assembly that came with the Owner's Manual must be installed when installing the optional icemaker kit. Please call 800.626.2002 and order part WR13X20070 if the water valve cover assembly is missing. In Canada, call 800.661.1616. Please follow instructions in the Water Valve Installation Procedure sheet attached to the back of the unit.

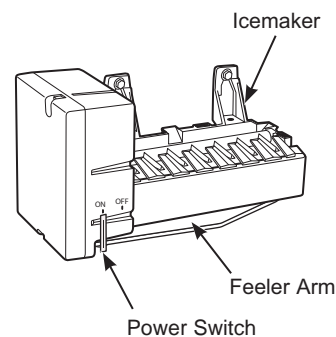

⚠ WARNING

Connect to potable water supply only.
A cold water supply is required for automatic icemaker operation. The water pressure must be between 40 and 120 psi (275-827 kilopascals)

Water Supply Kits

Kits containing copper tubing, shutoff valve, fittings and instructions needed to connect the icemaker to your cold water line are available at extra cost from your dealer or from Parts and Accessories. In the U.S., call 800.626.2002. In Canada, call 800.661.1616.

For water valve installation, please follow the instructions in the IM4D Icemaker Accessory Kit Owner's Manual and the Water Valve Installation Procedure sheet attached to the back of the unit.

Notes

Consumer Support

GE Appliances Website

Have a question or need assistance with your appliance? Try the GE Appliances Website 24 hours a day, any day of the year! You can also shop for more great GE Appliances products and take advantage of all our on-line support services designed for your convenience. In the US: GEAppliances.com In Canada: GEAppliances.ca

Register Your Appliance

Register your new appliance on-line at your convenience! Timely product registration will allow for enhanced communication and prompt service under the terms of your warranty, should the need arise. You may also mail in the pre-printed registration card included in the packing material.

In the US: GEAppliances.com/register

In the Canada: Prodsupport.mabe.ca/crm/Products/ProductRegistration.aspx

Schedule Service

Expert GE Appliances repair service is only one step away from your door. Get on-line and schedule your service at your convenience any day of the year. In the US: GEAppliances.com/service or call 800.432.2737 during normal business hours.

In Canada: GEAppliances.ca/en/support/service-request or call 800.561.3344

Extended Warranties

Purchase a GE Appliances extended warranty and learn about special discounts that are available while your warranty is still in effect. You can purchase it on-line anytime. GE Appliances Services will still be there after your warranty expires.

In the US: GEAppliances.com/extended-warranty or call 800.626.2224 during normal business hours.

In Canada: GEAppliances.ca/en/support/purchase-extended-warranty or call 800.290.9029

Remote Connectivity

For assistance with wireless network connectivity (for models with remote enable), visit our website at GEAppliances.com/connect or call 800.220.6899.

In Canada: [GEAppliances.ca/ connected-home-smart-appliances/](http://GEAppliances.ca/connected-home-smart-appliances/) or call 800.220.6899.

Parts and Accessories

Individuals qualified to service their own appliances can have parts or accessories sent directly to their homes (VISA, MasterCard and Discover cards are accepted). Order on-line today 24 hours every day.

In the US: GEApplianceparts.com or by phone at 877.959.8688 during normal business hours.

Instructions contained in this manual cover procedures to be performed by any user. Other servicing generally should be referred to qualified service personnel. Caution must be exercised, since improper servicing may cause unsafe operation.

Customers in Canada should consult the yellow pages for the nearest Mabe service center, visit our website at GEAppliances.ca/en/products/parts-filters-accessories or call 800.661.1616.

Contact Us

If you are not satisfied with the service you receive from GE Appliances, contact us on our Website with all the details including your phone number, or write to:

In the US: General Manager, Customer Relations | GE Appliances, Appliance Park | Louisville, KY 40225

GEAppliances.com/contact

In Canada: Director, Consumer Relations, Mabe Canada Inc. | Suite 310, 1 Factory Lane | Moncton, N.B. E1C 9M3

GEAppliances.ca/en/contact-us
