



WALL CHIMNEY VENT HOODS

SAFETY INFORMATION3

USING THE HOOD

Controls5

Filter 6

CARE AND CLEANING

Surfaces8

Lights8

TROUBLESHOOTING TIPS10

WARRANTY.....14

ACCESSORIES15

CONSUMER SUPPORT16

OWNER'S MANUAL

- JVW5301 (30" Pyramid)
- JVW5361 (36" Pyramid)
- PVW7301 (30" Glass)
- PVW7361 (36" Glass)

Write the model and serial numbers here:

Model # _____

Serial # _____

You can find them on a label on the inside of the hood.

ESPAÑOL

Para consultar una version en español de este manual de instrucciones, visite nuestro sitio de internet GEAppliances.com.

THANK YOU FOR MAKING GE APPLIANCES A PART OF YOUR HOME.

Whether you grew up with GE Appliances, or this is your first, we're happy to have you in the family.

We take pride in the craftsmanship, innovation and design that goes into every GE Appliances product, and we think you will too. Among other things, registration of your appliance ensures that we can deliver important product information and warranty details when you need them.

Register your GE appliance now online. Helpful websites and phone numbers are available in the Consumer Support section of this Owner's Manual. You may also mail in the pre-printed registration card included in the packing material.



GE APPLIANCES

IMPORTANT SAFETY INFORMATION

READ ALL INSTRUCTIONS BEFORE USING

⚠ WARNING TO REDUCE THE RISK OF FIRE, ELECTRIC SHOCK OR INJURY TO PERSONS, OBSERVE THE FOLLOWING:

- A. Use this unit only in the manner intended by the manufacturer. If you have questions, contact the manufacturer.
- B. Before servicing or cleaning unit, switch power off at service panel and lock the service disconnecting means to prevent power from being switched on accidentally. When the service disconnecting means cannot be locked, securely fasten a prominent warning device, such as a tag, to the service panel.
- C. Do not use this unit with any solid-state speed control device.
- D. This unit must be grounded.

⚠ CAUTION FOR GENERAL VENTILATING USE ONLY. DO NOT USE TO EXHAUST HAZARDOUS OR EXPLOSIVE MATERIALS AND VAPORS.

⚠ CAUTION TO REDUCE RISK OF FIRE AND TO PROPERLY EXHAUST AIR, BE SURE TO DUCT AIR OUTSIDE. DO NOT VENT EXHAUST AIR INTO SPACES WITHIN WALLS OR CEILINGS OR INTO ATTICS, CRAWL SPACES OR GARAGES.

⚠ WARNING TO REDUCE THE RISK OF INJURY TO PERSONS IN THE EVENT OF A RANGE TOP GREASE FIRE, OBSERVE THE FOLLOWING*:

- A. SMOTHER FLAMES with a close-fitting lid, cookie sheet or metal tray, then turn off the burner. BE CAREFUL TO PREVENT BURNS. If the flames do not go out immediately, EVACUATE AND CALL THE FIRE DEPARTMENT.
- B. NEVER PICK UP A FLAMING PAN—You may be burned.
- C. DO NOT USE WATER, including wet dishcloths or towels—a violent steam explosion will result.
- D. Use an extinguisher ONLY if:
 1. You know you have a Class ABC extinguisher, and you already know how to operate it.
 2. The fire is small and contained in the area where it started.
 3. The fire department is being called.
 4. You can fight the fire with your back to an exit.

*Based on "Kitchen Fire Safety" published by NFPA.

READ AND SAVE THESE INSTRUCTIONS

IMPORTANT SAFETY INFORMATION

READ ALL INSTRUCTIONS BEFORE USING

▲WARNING TO REDUCE THE RISK OF A RANGE TOP GREASE FIRE:

- A. Never leave surface units unattended at high settings. Boilovers cause smoking and greasy spillovers that may ignite. Heat oils slowly on medium settings.
- B. Always turn hood ON when cooking at high heat or when flambéing food (i.e. Crepes Suzette, Cherries Jubilee, Peppercorn Beef Flambé).
- C. Clean ventilating fans frequently. Grease should not be allowed to accumulate on fan or filter.
- D. Use proper pan size. Always use cookware appropriate for the size of the surface element.

▲WARNING TO REDUCE THE RISK OF FIRE, ELECTRIC SHOCK OR INJURY TO PERSONS, OBSERVE THE FOLLOWING:

- A. Installation work and electrical wiring must be done by qualified person(s) in accordance with all applicable codes and standards, including fire-rated construction.
- B. Sufficient air is needed for proper combustion and exhausting of gases through the flue (chimney) of fuel burning equipment to prevent back drafting. Follow the heating equipment manufacturer's guidelines and safety standards such as those published by the National Fire Protection Association (NFPA), the American Society for Heating, Refrigeration and Air Conditioning Engineers (ASHRAE) and the local code authorities.

- C. When cutting or drilling into wall or ceiling, do not damage electrical wiring and other hidden utilities.
- D. Ducted fans must always be vented to the outdoors.
- E. When applicable, install any makeup (replacement) air system in accordance with local building code requirements. Visit GEAppliances.com for available makeup air solutions.
- F. Turn off breaker to adjacent rooms while working.

▲WARNING TO REDUCE THE RISK OF FIRE, USE ONLY METAL DUCTWORK.

- Do not attempt to repair or replace any part of your hood unless it is specifically recommended in this manual. All other servicing should be referred to a qualified technician.

How to Remove Protective Shipping Film and Packaging Tape

Carefully grasp a corner of the protective shipping film with your fingers and slowly peel it from the appliance surface. Do not use any sharp items to remove the film. Remove all of the film before using the appliance for the first time.

To assure no damage is done to the finish of the product, the safest way to remove the adhesive from packaging tape on new appliances is an application of a household liquid dishwashing detergent. Apply with a soft cloth and allow to soak. **NOTE:** If surface is still not clean, see page 8 for more cleaning options.

NOTE: The adhesive must be removed from all parts.

READ AND SAVE THESE INSTRUCTIONS

Controls

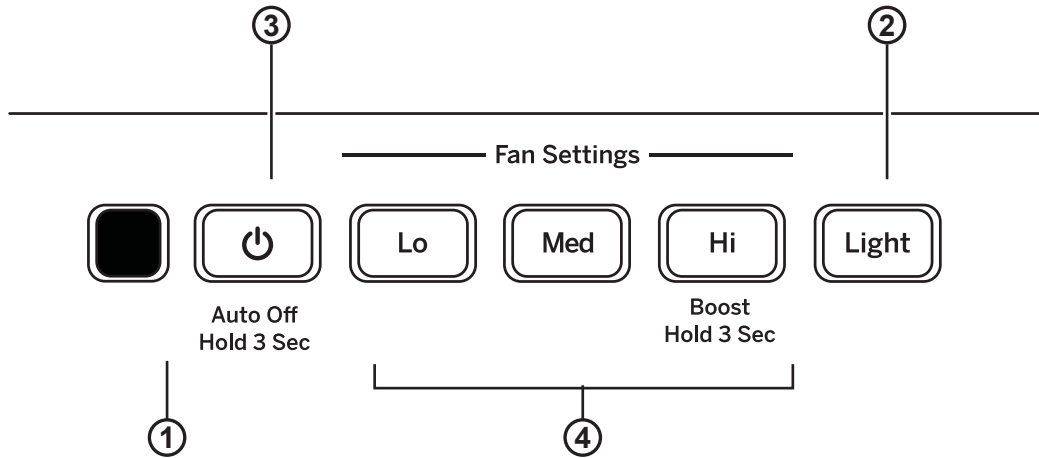

- 1. Rangehood Control Panel:** The control panel is located on the front of the canopy. The position and function of each control button are noted below.
- 2. Light Button:** On/Night/Off switch for the halogen lights. Press the **LIGHT** button to turn the lights on, again to set the lights to night setting, and again to turn off.
- 3. Fan Off Button:** Off switch for the fan. The fan can be operated by pressing any of the fan setting buttons. Hold for 2 seconds to activate auto off after 15 minutes.
- 4. Fan Settings Buttons:** Speed control for fan. Press the switch **Lo** for LOW speed, **Med** for MEDIUM speed and **Hi** for HIGH speed. Hold down the **Hi** button for 2 seconds to activate the BOOST SPEED that will run for 10 minutes.

Filters (Pyramid Models JVW5301, JVW5361)

Be sure the circuit breaker is off and all surfaces are cool before cleaning or servicing any part of the vent hood.

Metal Grease Filter

The metal filters trap grease during cooking.

The filters must ALWAYS be in place when the hood is in use. The grease filters are dishwasher-safe and should be cleaned every 6 months, or as needed.

To remove:

Pull downward on the filter lock to release the filter.

To replace:

Fit the tabs at the bottom of the filter into the slots in the back of the filter opening. Lift up the front side of the filter and push gently until the filter locks into place. Make sure the filter lock is in the closed position to secure the filter.

To clean, swish the filter in hot soapy water and rinse in clean water or wash it in the dishwasher. Do not use abrasive cleansers.

NOTE: Some discoloration may occur in the dishwasher.

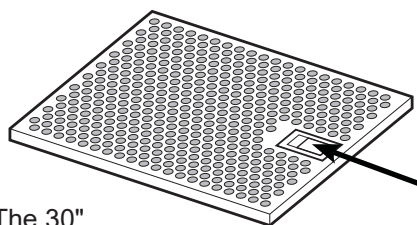

NOTE: The 30" models have 2 grease filters. The 36" models have 3 grease filters.

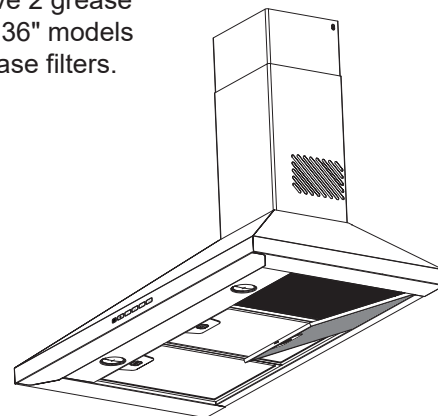

For Recirculation Installation Only

Charcoal Filter (Not Included)

If the model is not vented to the outside, the air needs to be recirculated through a disposable charcoal filter that helps remove smoke and odors.

NOTE: DO NOT rinse, or put charcoal filter in an automatic dishwasher.

The charcoal filter cannot be cleaned. It must be replaced. It is recommended that the charcoal filter be replaced every 6-12 months or if it is noticeably dirty or discolored.

Order Charcoal Filter JXCF72

To inquire about purchasing replacement charcoal filters or to find the location of a dealer nearest you, please call our toll-free number:

National Parts Center 800.626.2002

To install:

1. Remove the metal filters—see Metal grease filter section.
2. Place the side of the charcoal filter with the tabs against the side of the blower.
3. Align the double lines on the charcoal filter with the "unlocked" symbol on the blower.
4. Push and twist the charcoal filter downward until the double lines align with the "locked" symbol on the blower.
5. Repeat with second filter on the other side of the blower.
6. Replace the metal filters—see Metal grease filter section.

To remove:

1. Remove the metal filters—see Metal grease filter section.
2. Twist the charcoal filters upward on both sides of the motor to align the double lines with the "unlocked" symbol. The locks are now disengaged and the charcoal filters can be removed.

To remove:

1. Remove the metal filters—see Metal grease filter section.
2. Unclip the charcoal filter by pressing the release clip.
3. Carefully remove charcoal filter from tab.

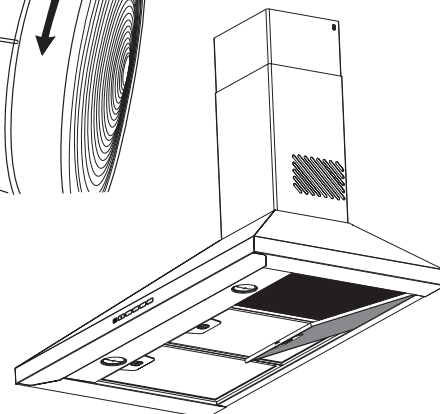
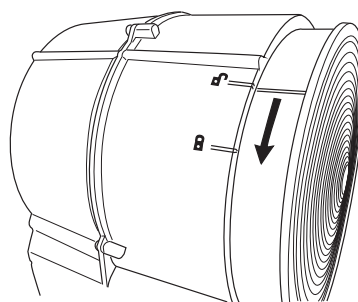

Filters (Glass Models PVW7301, PVW7361)

Be sure the circuit breaker is off and all surfaces are cool before cleaning or servicing any part of the vent hood.

Metal Grease Filter

The metal filter traps grease released by foods from cooking.

The filters must ALWAYS be in place when the hood is in use. The grease filters are dishwasher-safe and should be cleaned every 6 months, or as needed.

To remove:

Pull downward on the filter lock to release the filter.

To replace:

Fit the tabs at the bottom of the filter behind the ledge of the filter opening. Lift up the front side of the filter, push downward on the filter lock, and push gently until the filter is in place. Release the filter lock to secure the filter in place.

To clean, swish the filter in hot soapy water and rinse in clean water or wash it in the dishwasher. Do not use abrasive cleansers.

NOTE: Some discoloration may occur in the dishwasher.

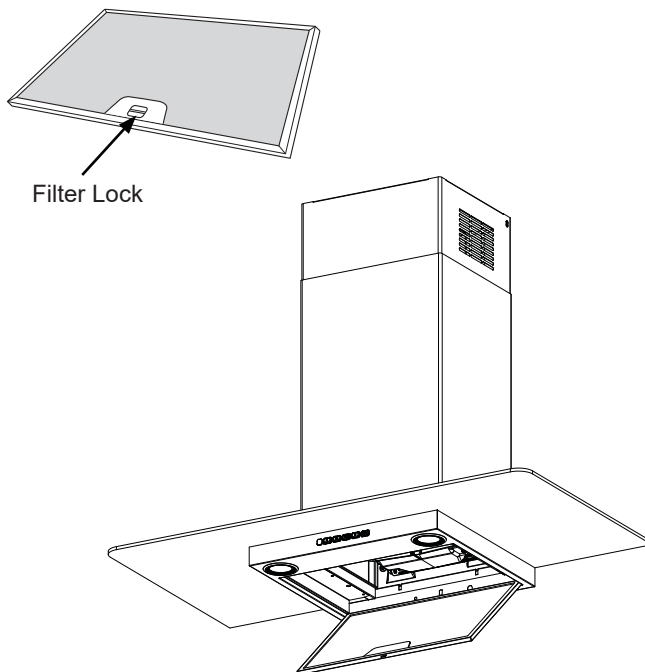

For Recirculation Installation Only

Charcoal Filter (Not Included)

If the model is not vented to the outside, the air needs to be recirculated through a disposable charcoal filter that helps remove smoke and odors.

NOTE: DO NOT rinse, or put charcoal filter in an automatic dishwasher.

The charcoal filter cannot be cleaned. It must be replaced. It is recommended that the charcoal filter be replaced every 6-12 months or if it is noticeably dirty or discolored.

Order Charcoal Filter JXCF71

To inquire about purchasing replacement charcoal filters or to find the location of a dealer nearest you, please call our toll-free number:

National Parts Center 800.626.2002

To install:

1. Insert the bottom tabs of the charcoal filter into the two slots at the back of the unit. Pivot filter upward into place while depressing the locking tabs.
2. Replace the metal filter—see Metal grease filter section.

To remove:

1. Remove the metal filter—see Metal grease filter section.
2. Press on the two tabs on the charcoal filter to disengage the lock and pivot to remove.

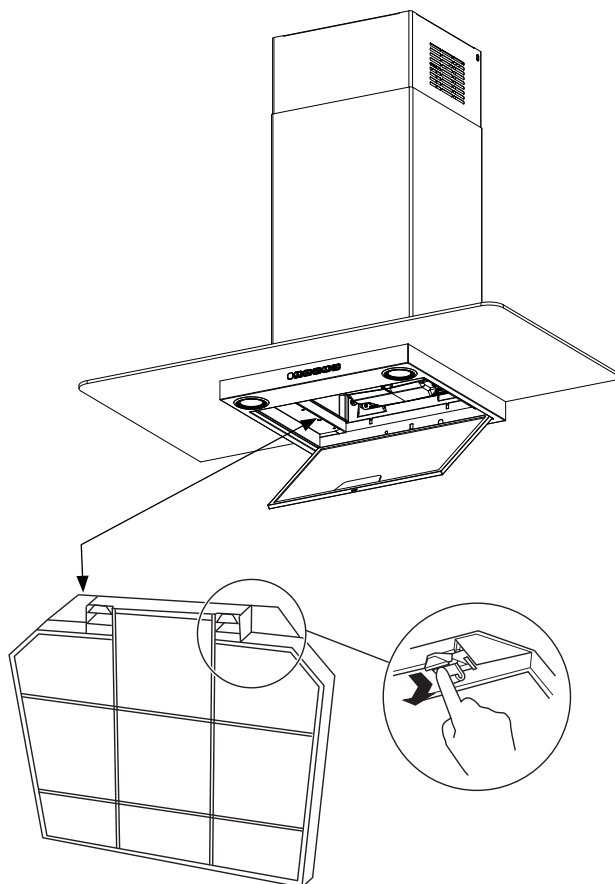

Surfaces

Stainless Steel Surfaces (on some models)

Do not use a steel wool pad; it will scratch the surface.

To clean the stainless steel surface, use warm sudsy water or a stainless steel cleaner or polish. Always wipe the surface in the direction of the brush line. Follow the cleaner instructions for cleaning the stainless steel surface. Cleaners with oxalic acid such as **Bar Keepers Friend Soft Cleanser™** will remove surface rust, tarnish, and small blemishes. Use only a liquid cleanser free of grit and rub in the direction of the brush lines with a damp soft sponge.

To inquire about purchasing stainless steel appliance cleaner or polish, or to find the location of a dealer nearest you, please call our toll-free number:

National Parts Center

800.626.2002

GEApplianceParts.com

Painted Surfaces (on some models)

Do not use a steel wool pads or other abrasive cleaners; they will scratch the surface.

Clean grease-laden surfaces of the hood frequently. To clean the hood surface, use a hot, damp cloth with a mild detergent suitable for painted surfaces. About one tablespoon of ammonia may be added to the water. Use a clean, hot, damp cloth to remove soap. Dry with a dry, clean cloth.

NOTE: When cleaning, take care not to come in contact with filters and other surfaces.

CAUTION When cleaning the hood surfaces, be certain that you do not touch the light with moist hands or cloth. A warm or hot light may break if touched with a moist surface. Always let the light cool completely before cleaning around it.

Lights (Pyramid Models JVV5301, JVV5361)

CAUTION Allow lights to cool before touching.

To change the lights:

1. Before attempting to replace the lights, make sure that the light switch is turned off.
2. Using a flathead screwdriver, unclip the wire lighting support and gently pull the support down from the hood.
3. While holding the socket, twist the light counter-clockwise to remove. Replace it with a new GU-10 light. Make sure the new light is locked in the socket.
4. Replace the new light and socket into the hood and engage into the light support.

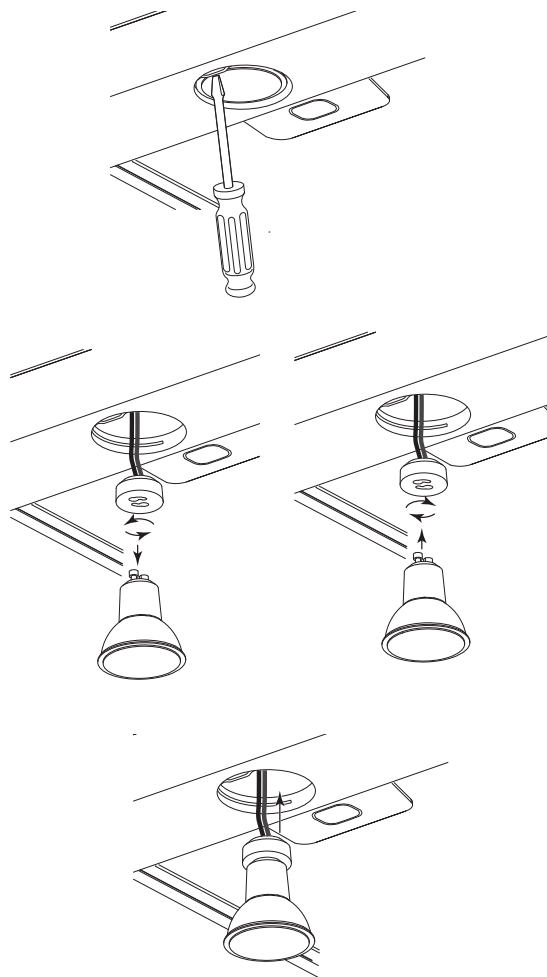

Lights (Glass Models PVW7301, PVW7361)

▲ CAUTION Allow lights to cool before touching.

To change the lights:

1. Before attempting to replace the lights, make sure that the light switch is turned off.
2. Wear gloves. Do not touch the light with your bare fingers. Skin oils can cause early light failure. Wear clean gloves or use a paper towel to handle the light.
3. Using a flathead screwdriver, unclip the metal trim ring from the lighting support.
4. Remove the light by pulling towards the front of the hood. Replace it with a new G4 20W Clear Halogen Capsule light by inserting the two stakes into the holes and pushing towards the back of the hood to secure the light.
5. Reinsert the metal trim ring by lining up the two side holes on the lighting support with the two tabs on the trim ring, and push upward.

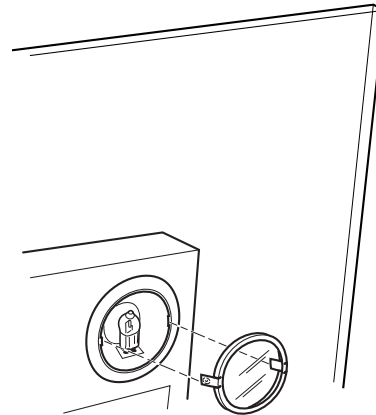
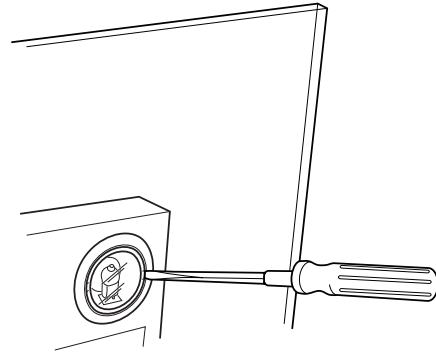

Troubleshooting Tips ... Before you call for service

Save time and money! Review the charts on the following pages first and you may not need to call for service.

Problem	Possible Cause	What To Do
Fan/Light does not operate when either button is pressed	A house fuse may be blown or a circuit breaker tripped.	Replace fuse or reset circuit breaker.
Fan does not operate when fan Lo, Med, Hight buttons are pressed	The blower connector is loose or not plugged into its mating connector.	Disconnect power to the unit. Remove the filters and look up at the blower. If the blower connector plug is loose or you see the connector dangling, the installer failed to plug it in securely. See the mini manual for the plug location and how to plug in the connector.
Loud or abnormal airflow noise	Wrong duct size used in installation.	This hood requires 6" ducting to perform optimally. Using smaller duct pipe will cause reduced venting. Minimize the duct run length and number of transitions and elbows. GE service technicians cannot correct this issue if installed improperly.
Fan fails to circulate air or moves air slower than normal and/or fan is making loud or abnormal airflow noise	Obstructions in duct work.	Make sure nothing is blocking the vent. Make sure your wall or roof cap has a blade or door.
	Damper blade on wall or roof cap may not be open.	Make sure damper swings freely. Damper blades may flip over and will not fully open when this happens. Adjust to original position.
	Metal grease filter and charcoal filter (if present) may be dirty.	Clean the metal grease filter and replace charcoal filter (if present). See Care and Cleaning of the Vent Hood.
	Insufficient makeup (replacement) air	Sufficient makeup (replacement) air is required for exhausting appliances to operate to rating. Check with local building codes, which may require or strongly advise the use of makeup air. Visit GEAppliances.com for available makeup air solutions.
The hood controls are not operating correctly	Control logic confused.	Disconnect power to the hood by resetting the circuit breaker. Wait 30 seconds to allow controls to reset.
Early light failure	Replacing lights with bare hands.	Replace lights while wearing gloves to keep skin oils off lights.
	Light wattage is too high.	Replace with correct wattage.

Notes

Notes

Notes

GE Appliances Vented Range Hood Warranty

GEAppliances.com

All warranty service is provided by our Factory Service Centers, or an authorized Customer Care® technician. To schedule service online, visit us at www.geappliances.com/service_and_support/, or call GE Appliances at 800.GE.CARES (800.432.2737). Please have your serial number and your model number available when calling for service.

Servicing your appliance may require the use of the onboard data port for diagnostics. This gives a GE Appliances factory service technician the ability to quickly diagnose any issues with your appliance and helps GE Appliances improve its products by providing GE Appliances with information on your appliance. If you do not want your appliance data to be sent to GE Appliances, please advise your technician not to submit the data to GE Appliances at the time of service.

For the period of	GE Appliances will replace
One year From the date of the original purchase	Any part of the cooking product which fails due to a defect in materials or workmanship. During this limited one-year warranty , GE Appliances will provide, free of charge , all labor and related service costs to replace the defective part.

What GE Appliances will not cover:

- Service trips to your home to teach you how to use the product.
- Improper installation, delivery, or maintenance.
- Failure of the product if it is abused, misused, modified, or used for other than the intended purpose or used commercially.
- Replacement of house fuses or resetting of circuit breakers.
- Damage to the product caused by accident, fire, floods, or acts of God.
- Damage to finish, such as surface rust, tarnish, or small blemishes not reported within 48 hours of delivery.
- Incidental or consequential damage caused by possible defects with this appliance.
- Damage caused after delivery.
- Product not accessible to provide required service.
- Service to repair or replace light bulbs, except for LED lamps.

EXCLUSION OF IMPLIED WARRANTIES

Your sole and exclusive remedy is product repair as provided in this Limited Warranty. Any implied warranties, including the implied warranties of merchantability or fitness for a particular purpose, are limited to one year or the shortest period allowed by law.

This warranty is extended to the original purchaser and any succeeding owner for products purchased for home use within the USA. If the product is located in an area where service by a GE Appliances Authorized Servicer is not available, you may be responsible for a trip charge or you may be required to bring the product to an Authorized GE Appliances Service location for service. In Alaska, the warranty excludes the cost of shipping or service calls to your home. Some states do not allow the exclusion or limitation of incidental or consequential damages. This warranty gives you specific legal rights, and you may also have other rights which vary from state to state. To know what your legal rights are, consult your local or state consumer affairs office or your state's Attorney General.

Warrantor: GE Appliances, a Haier company

Extended Warranties: Purchase a GE Appliances extended warranty and learn about special discounts that are available while your warranty is still in effect. You can purchase it online anytime at

www.geappliances.com/service_and_support/shop-for-extended-service-plans.htm

or call 800.626.2224 during normal business hours. GE Appliances Service will still be there after your warranty expires.

Staple your receipt here. Proof of the original purchase date is needed to obtain service under the warranty.

Accessories

Looking For Something More?

GE Appliances offers a variety of accessories to improve your cooking and maintenance experiences!

Refer to the Consumer Support page for phone numbers and website information.

The following products and more are available:

Parts

Charcoal Filter

High Ceiling Duct Cover Kit

Remote Control

Replacement Lights

Cleaning Supplies

CitruShine™ Stainless Steel Wipes

CERAMA BRYTE® Stainless Steel Appliance Cleaner

Bar Keepers Friend Soft Cleanser™

Consumer Support

GE Appliances Website

Have a question or need assistance with your appliance? Try the GE Appliances Website 24 hours a day, any day of the year! You can also shop for more great GE Appliances products and take advantage of all our on-line support services designed for your convenience. In the US: GEAppliances.com

Register Your Appliance

Register your new appliance on-line at your convenience! Timely product registration will allow for enhanced communication and prompt service under the terms of your warranty, should the need arise. You may also mail in the pre-printed registration card included in the packing material. In the US: GEAppliances.com/register

Schedule Service

Expert GE Appliances repair service is only one step away from your door. Get on-line and schedule your service at your convenience any day of the year. In the US: GEAppliances.com/ge/service-and-support/service.htm or call 800.432.2737 during normal business hours.

Extended Warranties

Purchase a GE Appliances extended warranty and learn about special discounts that are available while your warranty is still in effect. You can purchase it on-line anytime. GE Appliances Services will still be there after your warranty expires. In the US: GEAppliances.com/ge/service-and-support/shop-for-extended-service-plans.htm or call 800.626.2224 during normal business hours.

Remote Connectivity

For assistance with wireless network connectivity (for models with remote enable), visit our website at GEAppliances.com/ge/connected-appliances/ or call 800.220.6899 in the US.

Parts and Accessories

Individuals qualified to service their own appliances can have parts or accessories sent directly to their homes (VISA, MasterCard and Discover cards are accepted). Order on-line today 24 hours every day. In the US: GEApplianceparts.com or by phone at 877.959.8688 during normal business hours.

Instructions contained in this manual cover procedures to be performed by any user. Other servicing generally should be referred to qualified service personnel. Caution must be exercised, since improper servicing may cause unsafe operation.

Contact Us

If you are not satisfied with the service you receive from GE Appliances, contact us on our Website with all the details including your phone number, or write to:

In the US: General Manager, Customer Relations | GE Appliances, Appliance Park | Louisville, KY 40225
GEAppliances.com/ge/service-and-support/contact.htm