



Bottom-Freezer REFRIGERATORS

SAFETY INFORMATION3

USING THE REFRIGERATOR

Controls5

Shelves and Racks and Pans6

Door Bins.....7

Freezer Drawers.....7

CARE AND CLEANING8

INSTALLATION INSTRUCTIONS

Preparing to Install the Refrigerator.....10

Reversing the Door Swing 11

TROUBLESHOOTING

Normal Operating Sounds13

Troubleshooting Tips.....14

LIMITED WARRANTY16

ACCESSORY.....17

Icemaker Installation Instructions 18

CONSUMER SUPPORT28

OWNER'S MANUAL & INSTALLATION INSTRUCTIONS

GLE12HSLSS
GLE12HSPSS

ENGLISH/FRANÇAIS/
ESPAÑOL

Write the model and serial numbers here:

Model # _____

Serial # _____

Find these numbers on a label inside the fresh food compartment.

THANK YOU FOR MAKING GE APPLIANCES A PART OF YOUR HOME.

Whether you grew up with GE Appliances, or this is your first, we're happy to have you in the family.

We take pride in the craftsmanship, innovation and design that goes into every GE Appliances product, and we think you will too. Among other things, registration of your appliance ensures that we can deliver important product information and warranty details when you need them.

Register your GE appliance now online. Helpful websites and phone numbers are available in the Consumer Support section of this Owner's Manual. You may also mail in the pre-printed registration card included in the packing material.



IMPORTANT SAFETY INFORMATION

READ ALL INSTRUCTIONS BEFORE USING THE APPLIANCE

⚠ WARNING To reduce the risk of fire, explosion, electric shock, or injury when using your refrigerator, follow these basic safety precautions:

- This refrigerator must be properly installed and located in accordance with the Installation Instructions before it is used.
- Unplug the refrigerator before making repairs, replacing a light bulb, or cleaning.
NOTE: Power to the refrigerator cannot be disconnected by any setting on the control panel.
NOTE: Repairs must be performed by a qualified Service Professional.
- Replace all parts and panels before operating.
- Do not store or use gasoline or other flammable vapors and liquids in the vicinity of this or any other appliance.
- Do not store explosive substances such as aerosol cans with a flammable propellant in this appliance.
- Do not use an extension cord.
- To prevent suffocation and entrapment hazards to children, remove the fresh food and freezer doors from any refrigerator before disposing of it or discontinuing its use.
- To avoid serious injury or death, children should not stand on, or play in or with the appliance.
- Children and persons with reduced physical, sensory or mental capabilities or lack of experience and knowledge can use this appliance only if they are supervised or have been given instructions on safe use and understand the hazards involved.
- This appliance is intended to be used in household and similar applications such as: staff kitchen areas in shops, offices and other working environments; farm houses; by clients in hotels, motels, bed & breakfast and other residential environments; catering and similar non-retail applications.
- Do not apply harsh cleaners to the refrigerator. Certain cleaners will damage plastic which may cause parts such as the door or door handles to detach unexpectedly. See the Care and Cleaning section for detailed instructions.

⚠ CAUTION To reduce the risk of injury when using your refrigerator, follow these basic safety precautions.

- Do not clean glass shelves or covers with warm water when they are cold. Glass shelves and covers may break if exposed to sudden temperature changes or impact, such as bumping or dropping. Tempered glass is designed to shatter into many small pieces if it breaks.
- Keep fingers out of the “pinch point” areas; clearances between the doors and between the doors and cabinet are necessarily small. Be careful closing doors when children are in the area.
- Do not touch the cold surfaces in the freezer compartment when hands are damp or wet, skin may stick to these extremely cold surfaces.
- Do not refreeze frozen foods which have thawed completely.
- In refrigerators with automatic ice makers, avoid contact with the moving parts of the ejector mechanism, or with the heating element that releases the cubes. Do not place fingers or hands on the automatic ice making mechanism while the refrigerator is plugged in.

⚠ WARNING  **EXPLOSION HAZARD Flammable Refrigerant**

This appliance contains isobutane refrigerant, R600a, a natural gas with high environmental compatibility. However, it is also combustible. Adhere to the warnings below to reduce the risk of injury or property damage.

1. When handling, installing and operating the appliance, care should be taken to avoid damage to the refrigerant tubing.
2. Service shall only be performed by authorized service personnel. Use only manufacturer-authorized service parts.
3. Dispose of refrigerator in accordance with Federal and Local Regulations. Flammable refrigerant and insulation material used require special disposal procedures. Contact your local authorities for the environmentally safe disposal of your refrigerator.
4. Keep ventilation openings in the appliance enclosures or in the built-in structure clear of obstruction.
5. Do not use mechanical devices or other means to accelerate the defrosting process.
6. Do not damage refrigerant circuit.
7. Do not use electrical appliances inside the food storage compartment of the appliance.

READ AND SAVE THESE INSTRUCTIONS

IMPORTANT SAFETY INFORMATION

READ ALL INSTRUCTIONS BEFORE USING THE APPLIANCE

INSTALLATION

⚠ WARNING EXPLOSION HAZARD

Keep flammable materials and vapors, such as gasoline, away from refrigerator. Failure to do so can result in fire, explosion, or death.

CONNECTING ELECTRICITY

⚠ WARNING ELECTRICAL SHOCK HAZARD

Plug into a grounded 3-prong outlet
 Do not remove the ground prong
 Do not use an adapter
 Do not use an extension cord.
 Failure to follow these instructions can result in death, fire, or electrical shock.

Do not, under any circumstances, cut or remove the third (ground) prong from the power cord. For personal safety, this appliance must be properly grounded.

The power cord of this appliance is equipped with a 3-prong (grounding) plug which mates with a standard 3-prong (grounding) wall outlet to minimize the possibility of electric shock hazard from this appliance.

Have the wall outlet and circuit checked by a qualified electrician to make sure the outlet is properly grounded.

Where a standard 2-prong wall outlet is encountered, it is your personal responsibility and obligation to have it replaced with a properly grounded 3-prong wall outlet. Do not use an adapter.

The refrigerator should always be plugged into its own individual electrical outlet which has a voltage rating that matches the rating plate.

A 115 Volt AC, 60 Hz, 15- or 20-amp fused, grounded electrical supply is required. This provides the best performance and also prevents overloading house wiring circuits which could cause a fire hazard from overheated wires.

Never unplug your refrigerator by pulling on the power cord. Always grip plug firmly and pull straight out from the outlet.

Immediately discontinue use of a damaged supply cord. If the supply cord is damaged, it must be replaced by a qualified service professional with an authorized service part from the manufacturer.

When moving the refrigerator away from the wall, be careful not to roll over or damage the power cord.

PROPER DISPOSAL OF YOUR OLD REFRIGERATOR

⚠ WARNING SUFFOCATION AND ENTRAPMENT HAZARD

Failure to follow these disposal instructions can result in death or serious injury

IMPORTANT: Child entrapment and suffocation are not problems of the past. Junked or abandoned refrigerators or freezers are still dangerous even if they will sit for "just a few days." If you are getting rid of your old refrigerator or freezer, please follow the instructions below to help prevent accidents.

Before You Throw Away Your Old Appliance

- Take off the fresh food and freezer doors.
- Leave the shelves in place so that children may not easily climb inside.

Refrigerant and Foam Disposal:

Dispose of refrigerator in accordance with Federal and Local Regulations. Flammable refrigerant and insulation material used require special disposal procedures. Contact your local authorities for the environmentally safe disposal of your refrigerator.

READ AND SAVE THESE INSTRUCTIONS

Controls

The control location for GLE12HSLSS model is on the outside of the Fresh Food door. For GLE12HSPSS model, it is on the left side wall of the inside of the Fresh Food compartment.

Refrigerator Temperature Control

This refrigerator has 3 temperature zones: **Fridge**, **Freezer**, **TempZone**. Their temperature ranges are: Fridge 33°F (0.6°C) to 41°F (5°C), Freezer -6°F (-21°) to 6°F (-14.4°), TempZone 32°F (0°C), 34°F (1.1°C), 36°F (2.2°C). Your refrigerator will come with the recommended factory setting at 37°F (2.8°C) for Fresh Food, 0°F (-17.8°C) for Freezer and 32°F (0°C) for TempZone pan. Temperature display will show the actual set temperature and the zone light (**Fridge**, **Freezer** or **TempZone**) will be on.

To adjust the Temperature for each zone, press **Zone Select**. The selected zone light will be on. Keep pressing to toggle between 3 temperature zones. Zone will be set after 3 seconds. Adjust the temperature by pressing **Temp Control**. The temperature display will show the temperature moving up as you press it. Once you find the temperature you want, the control will automatically set the refrigerator to this setting. You don't need to press any button.

TurboCool and TurboFreeze

During TurboCool, refrigerator temperature can reach 33°F (0.6°C). During TurboFreeze, freezer temperature can reach 13°F (-10.6°) if room temperature is above 73°F (22.8°C), -7°F (-21.7°C) if room temperature is below 73°F (22.8°C).

To enter **TurboCool** or **TurboFreeze** or both, press **mode**. **TurboCool** will light up. If you leave without pressing any button, **TurboCool** will be set. Pressing mode a second time will light up **TurboFreeze**; leave without pressing any button, **TurboFreeze** will be set.

Pressing mode a third time will light up both **TurboCool** and **TurboFreeze**; leave without pressing any button, both functions will be set.

To exit Turbo functions, press **mode** again.

NOTE: During Turbo modes, the refrigerator or freezer temperature can be adjusted..

Lock

Press the lock symbol, hold for 3 seconds. The circle around the lock symbol with light up and the control display will be locked. Buttons will not be active.

To exit the lock, press the lock symbol again and hold for 3 seconds. The light around the lock will go off.

NOTE: The display will turn off after 30 seconds if the control display has not been touched. Touch any button on the control panel and it will display again.

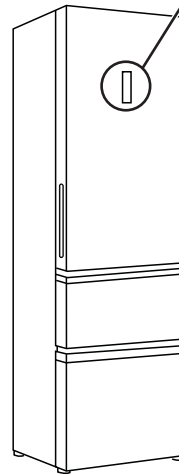
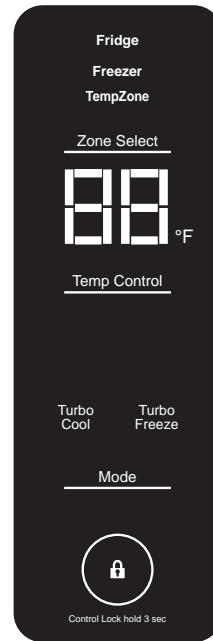

Model GLE12HSLSS

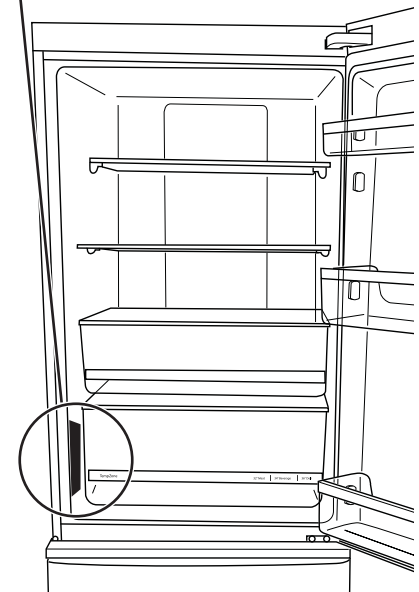

Model GLE12HSPSS

Sabbath Mode

Press the ZoneSelect and Temp Control simultaneously for 5 seconds to enter and exit Sabbath Mode. Activate Sabbath Mode to turn off interior lights, temperature control and advanced features. The compressor will run on a timed defrost when in Sabbath Mode. Sabbath Mode will last for 76 hours if you do not manually exit the mode.

Shelves and Racks and Pans

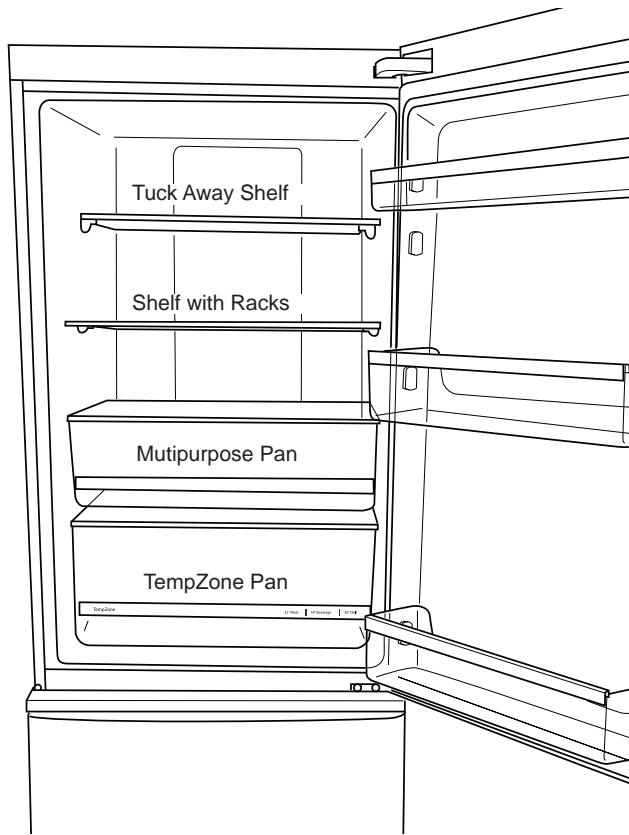

Tuck Away Shelf

To create space for large tall milk and drink bottles. Lift the back of the front shelf, pull out slightly and release the shelf. The back of the shelf will drop down automatically. Push the front shelf underneath the back shelf.

To remove the shelf, lift the front frame out of the clips and pull out.

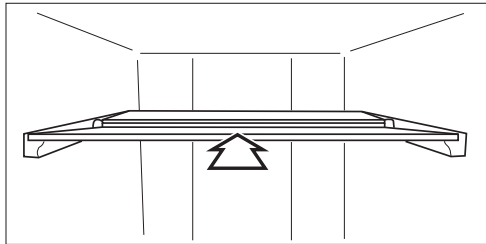

Shelf with Racks

Rotate both wine racks down as picture shown for wine storage. This shelf can be adjust to 2 locations

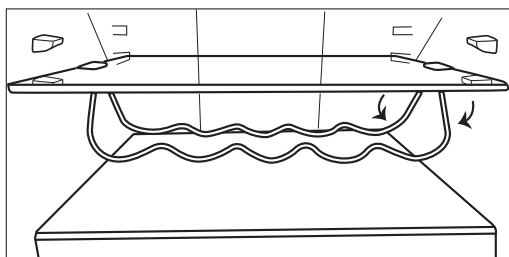

⚠ CAUTION

Do not clean glass shelves or covers with warm water when they are cold. Glass shelves and covers may break if exposed to sudden temperature changes or impact such as bumping or dropping. Tempered glass is designed to shatter into many small pieces if it breaks.

NOTE: Do not block air outlet by placing food items directly against it. Erratic temperatures may result.

Multipurpose Pan

This pan can use for storing vegetable, fruit, snack etc. To remove, pull the pan straight out.

TempZone Pan

Adjust the pan temperature through temperature control panel. This pan can have 3 temperature settings 32°F, 34°F, 36°F (0°C, 1.1°C, 2.2°C). It can be used as meat pan when it set at lowest temperature.

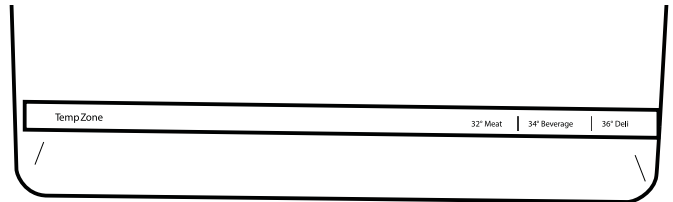

To remove TempZone pan, pull out pan (1), lift the pan cover slightly (2), tilt the pan up (3), pull the pan out (4).

To remove the pan cover, simply pull them straight out.

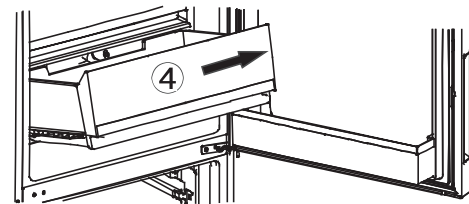
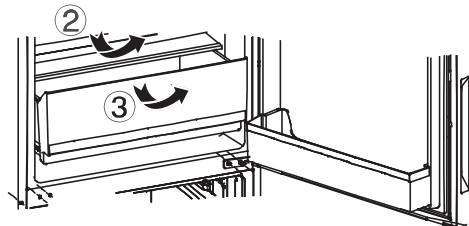
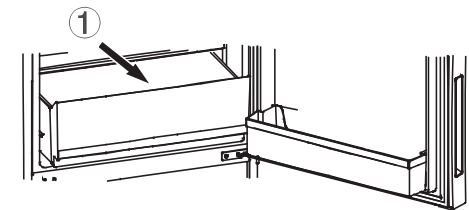

Door Bins

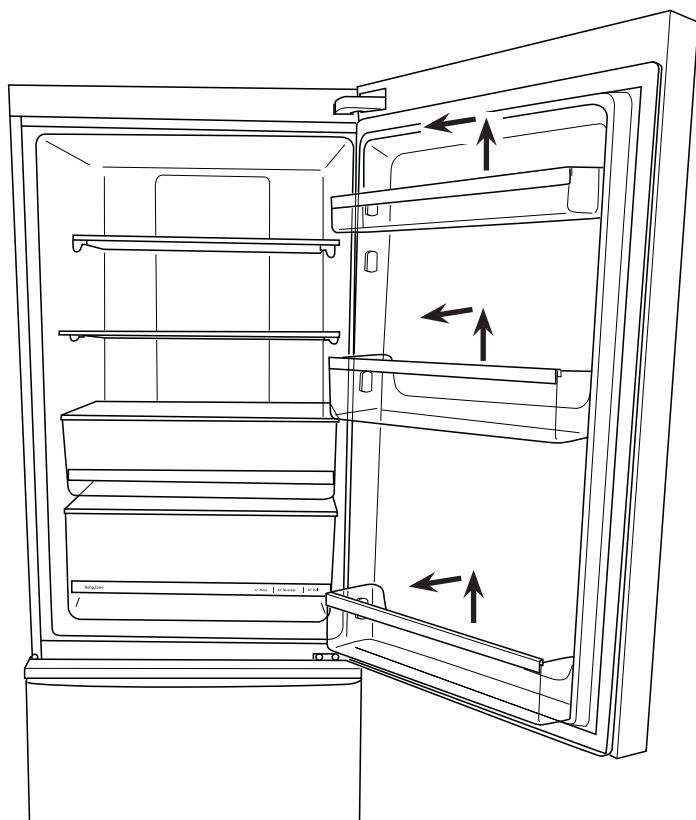

Fridge Door Bins

To remove door bins, slide bin up over the rib in the door and pull out.

To install door bins, slide the bin over the rib in the door. The small bin goes at the top on either set of ribs. Large bins go at the bottom and in the middle.

NOTE: Placing the door bins in the wrong locations will cause the Fresh Food door not to close.

Freezer Drawers

Upper Drawer

The divider can be placed in 2 positions for better organization of the drawer. Lift the divider out to remove it. Slip it over one of the 2 ribs in the drawer to install.

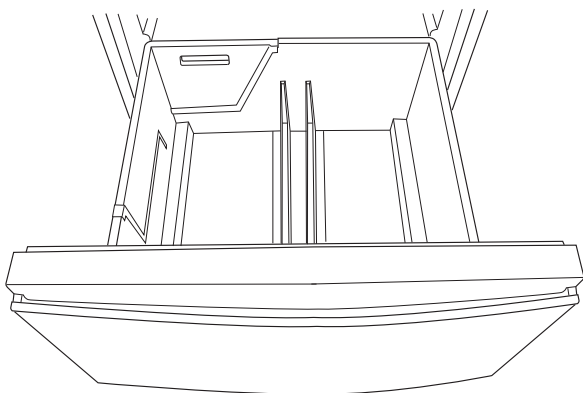

Lower Drawer

The lower drawer has a removable tray that slides back and forth to make more storage space. To remove the tray, lift it out of the drawer.

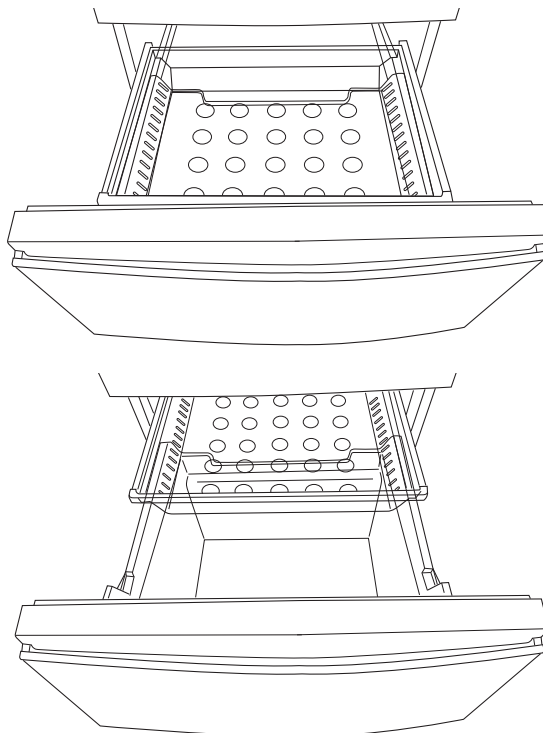

Care and Cleaning

Cleaning the Outside

Directions for Cleaning Outside Surfaces, Door Handles, and Trim

DO USE	DO NOT USE
Soft, clean cloth or sponge	Abrasive cloths, scrubbing sponges, scouring or steel wool pads
Mild detergent mixed with warm water Approved stainless steel cleaners; Visit the Café Appliances parts store for approved stainless steel cleaners: geapplianceparts.com or call 877.959.8688 Cleaners with oxalic acid such as Bar Keepers Friend Soft Cleanser™ can be used to remove surface rust, tarnish and small blemishes on stainless steel surfaces only.	Abrasive powders or sprays Window Sprays or Ammonia Citrus or plant oil-based cleaners Acidic or vinegar-based cleaners Oven cleaners Cleaners containing acetone (propanone) Any cleaner with WARNING about plastic contact

NOTE: DO NOT allow stainless steel cleaner to come in contact with any plastic parts such as trim pieces, handle hardware and liners. If unintentional contact of cleaners with plastic parts does occur, clean plastic part with a sponge and mild detergent mixed with warm water.

Cleaning the Inside

To help prevent odors, leave an open box of baking soda in the fresh food and freezer compartments.

Unplug the refrigerator before cleaning.

If this is not practical, wring excess moisture out of sponge or cloth when cleaning around switches, lights or controls.

Use warm water and baking soda solution—about a tablespoon (15 ml) of baking soda to a quart (1 liter) of water. This both cleans and neutralizes odors. Rinse and wipe dry.

After cleaning the door gaskets, apply a thin layer of petroleum jelly to the door gaskets at the hinge side. This helps keep the gaskets from sticking and bending out of shape.

⚠ CAUTION

Do not clean glass shelves or covers with warm water when they are cold. Glass shelves and covers may break if exposed to sudden temperature changes or impact such as bumping or dropping. Tempered glass is designed to shatter into many small pieces if it breaks.

Do not wash any plastic refrigerator parts in the dishwasher.

Moving the Refrigerator

Be careful when moving the refrigerator away from the wall. All types of floor coverings can be damaged, particularly cushioned coverings and those with embossed surfaces.

Pull the refrigerator straight out and return it to position by pushing it straight in. Moving the refrigerator in a side direction, or leaning the unit to the corner to pull or push, may result in damage to the floor covering or refrigerator.

When pushing the refrigerator back, make sure you don't roll over the power cord or ice maker supply line (on some models).

Adjust leveling legs and make sure the unit is leveled.

Light

This refrigerator has LED lighting. Call service if the light is broken or goes out.

The freezer light, located under the fresh food door, will only be on when the upper freezer drawer is open. No light will be on when the lower freezer drawer is open.

Care And Cleaning

Preparing for Vacation

For long vacations or absences, remove food and unplug the refrigerator. Unplug the refrigerator. This refrigerator will remember the current setting when you plug it in again. Clean the interior with a baking soda solution of one tablespoon (15 ml) of baking soda to one quart (1 liter) of water. Leave the doors open.

If an icemaker has been installed it must be turned off; move the switch to the OFF position on the power switch model. Shut off the water supply to the refrigerator.

If the temperature can drop below freezing, have a qualified servicer drain the water supply system (on some models) to prevent serious property damage due to flooding.

Preparing to Move

Secure all loose items, such as shelves and drawers, by taping them securely in place to prevent damage.

To prevent the doors from opening while moving, secure

them to the case with tape. Be sure the refrigerator stays in an upright position during moving.

Installation Instructions

If you have questions, call **1.800.GE.CARES** or visit our Website at: **GEAppliances.com**.
In Canada, call 1.800.561.3344 or Visit our Website at: **geappliances.ca**

BEFORE YOU BEGIN

Read these instructions completely and carefully.

- **IMPORTANT** – Save these instructions for local inspector's use.
- **IMPORTANT** – Observe all governing codes and ordinances.
- **Note to Installer** – Be sure to leave these instructions with the Consumer.
- **Note to Consumer** – Keep these instructions for future reference.
- **Skill level** – Installation of this appliance requires basic mechanical skills.
- **Completion time**—Refrigerator Installation
15 minutes
Reversing the Door Swing
15 minutes
- Proper installation is the responsibility of the installer.
- Product failure due to improper installation is not covered under the Warranty.

REFRIGERATOR LOCATION

- Do not install the refrigerator where the temperature will go below 55°F (12.7°C) because it will not run often enough to maintain proper temperatures.
- Do not install the refrigerator where the temperature will go above 100°F (37°C) because it will not perform properly.
- Do not install the refrigerator in a location exposed to water (rain, etc.) or direct sunlight.
- Install it on a floor strong enough to support it fully loaded.

CLEARANCES

Allow the following clearances for ease of installation, proper air circulation and plumbing and electrical connections.

Sides	1/8" (3 mm)
Top	1/8" (3 mm)
Back	1" (25 mm)

ROLLERS AND LEVELING LEGS

Leveling legs near each front corner of the refrigerator are adjustable. They firmly position the refrigerator and prevent it from moving when the doors are opened. Leveling legs should be set so the front of the refrigerator is raised just enough that the doors close easily when opened about halfway.

Turn the leveling legs **clockwise to raise** the refrigerator, **counterclockwise to lower it**.

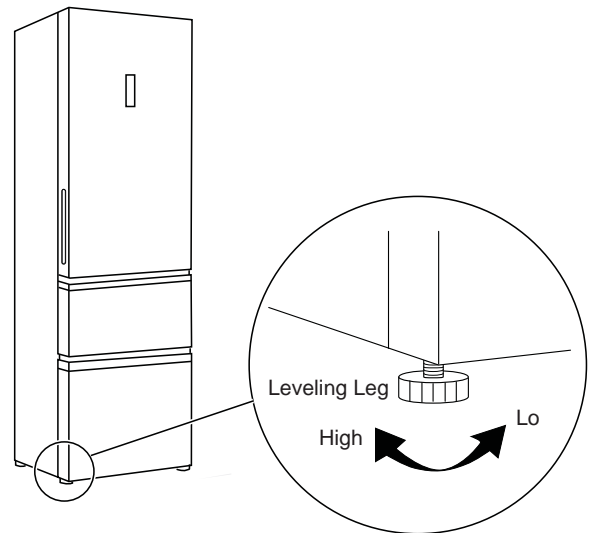

Installation Instructions

REVERSING THE DOOR SWING

⚠ WARNING Follow all steps when reversing the door swing. Failure to follow these instructions, leaving off parts, or overtightening screws, can lead to the door falling off and result in injury and property damage.

IMPORTANT NOTES

When reversing the door swing:

- Read the instructions all the way through before starting.
- Tighten all hinge screws but avoid over-tightening to prevent stripping.
- Handle parts carefully to avoid scratching paint.
- Set screws down by their related parts to avoid losing them.
- Provide a non-scratching work surface for the doors.

⚠ CAUTION **Lifting Hazard**

The Fresh Food and Freezer doors are heavy. Use both hands to secure the doors before lifting.

IMPORTANT: Once you begin, do not move the cabinet until door-swing reversal is completed.

These instructions are for changing the hinges from the right side to the left side—if you ever want to change the hinges back to the right side, follow these same instructions and reverse all references to left and right.

TOOLS REQUIRED



Phillips screwdriver



Masking tape



Pliers

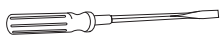

Flat head screwdriver

BEFORE YOU START

1. Unplug the refrigerator from its electrical outlet.
2. Empty all door shelves, including the dairy compartment.

IMPORTANT: Do not let door drop to the floor. To do so could damage the door stop.

1. Unscrew 4 screws on top of front case.
2. Remove top front case cover and cover insert. The cover insert slides out toward the bottom of the cover.

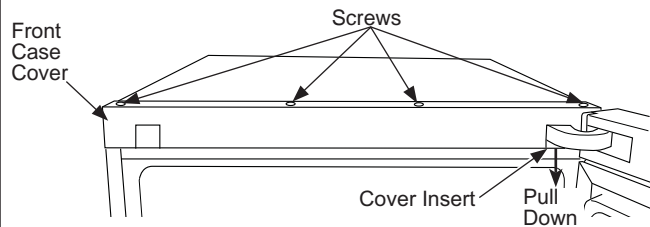

3. Remove the hinge cover. Carefully pull the wires free of the clips. Disconnect the wire.

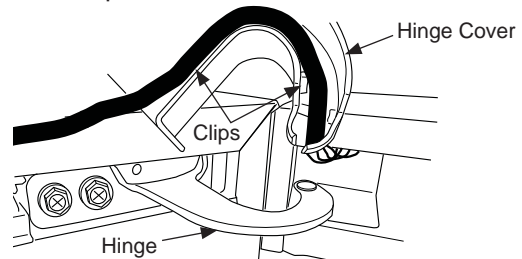

4. Remove the top door cap by inserting a flat head screw driver into the gap between the door cap and door case. Apply pressure to pop the door cap out.

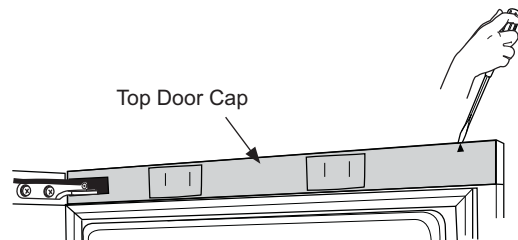

5. Unscrew the top hinge from the cabinet while holding the door.

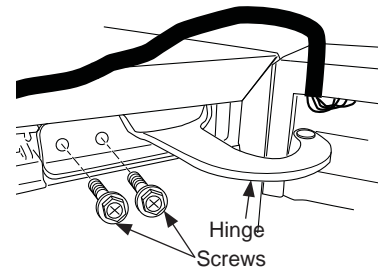

6. Lift the door straight off of the bottom hinge. Set the door aside.

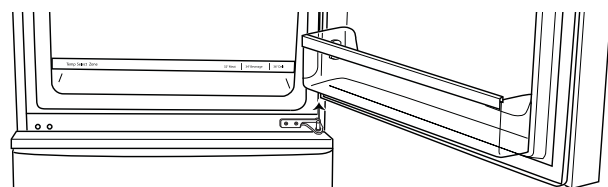

7. Unscrew and remove the bottom hinge from the cabinet.

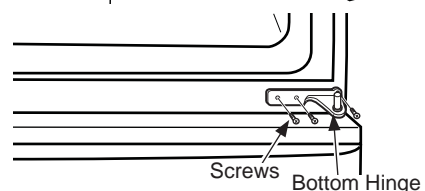

Installation Instructions

REVERSING THE DOOR SWING (CONT.)

⚠ WARNING Follow all steps when reversing the door swing. Failure to follow these instructions, leaving off parts, or overtightening screws, can lead to the door falling off and result in injury and property damage.

8. Remove the screw hole covers on the left side of the middle mullion where the new hinge will be installed. Place the screw hole covers over the holes where you removed the old hinge.

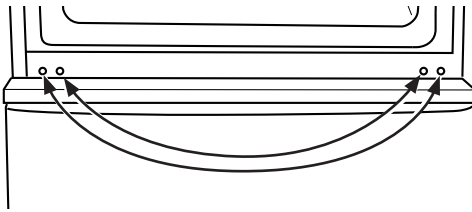

9. Install the new left bottom hinge that came with the unit into left side of the middle mullion. Place the door to new installed left bottom hinge.

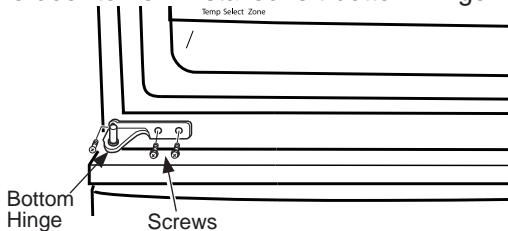

10. Remove the top hinge from the door. Set aside the right top and bottom hinges. Retain for returning door swing to original configuration.

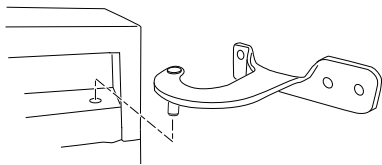

11. Unscrew the door stop from bottom right side of the door. Move the door stop to the bottom left side of the door. Line the door stop with locating pin, screw hole, and hinge pin hole at the bottom left side of door. Secure the stopper tightly using screw provided.

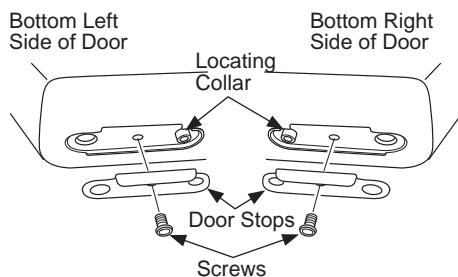

12. Install the top left hinge that came with the unit into the hinge hole on the top left of the door.

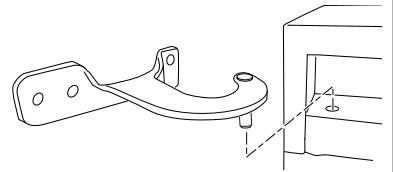

13. Using the screws provided, attach the top left hinge to the top of the case.

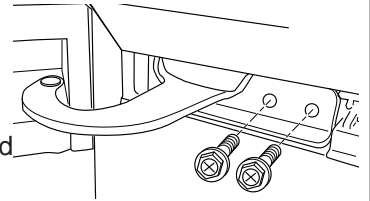

14. Connect the wire and redress wire around the hinge cover, top case and top of the door.

15. Place the new hinge cover on top of the hinge.

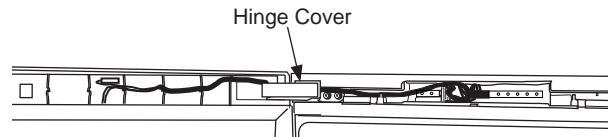

16. Turn the top door cap around and replace cap with the opening over the hinge cover. Press into place.

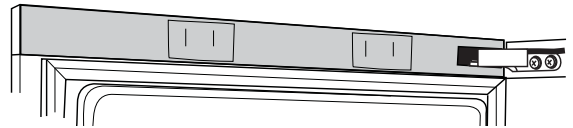

17. Pull down to remove the square insert on the left side of the front case cover. Slide this insert into the opening on the right side where the hinge cover was.

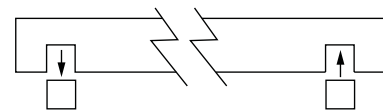

18. Replace the front case cover using the screws removed earlier. There are clips on the inside of the case cover that fit into notches on the case.

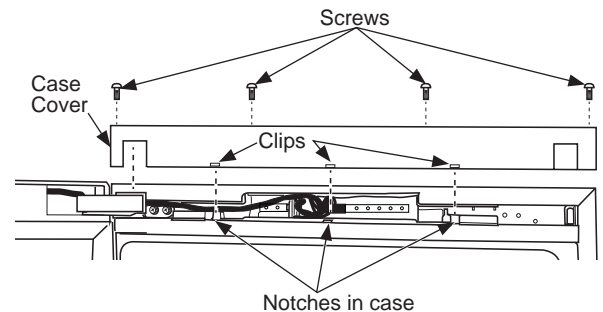

19. Install the cover insert under the hinge cover.

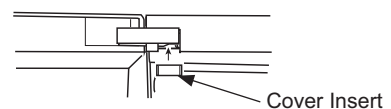

Normal Operating Sounds

Newer refrigerators sound different from older refrigerators. Modern refrigerators have more features and use newer technology.

Do you hear what I hear? These sounds are normal.

- The new high efficiency compressor may run faster and longer than your old refrigerator and you may hear a high-pitched hum or pulsating sound while it is operating.
- You may hear a whooshing sound when the doors close. This is due to pressure equalizing within the refrigerator.

HUMMM...
WHOOSH...



- You may hear the fans spinning at high speeds. This happens when the refrigerator is first plugged in, when the doors are opened frequently or when a large amount of food is added to the refrigerator or freezer compartments. The fans are helping to maintain the correct temperatures.

CLICKS, POPS, CRACKS and CHIRPS

- You may hear cracking or popping sounds when the refrigerator is first plugged in. This happens as the refrigerator cools to the correct temperature.
- The compressor may cause a clicking or chirping sound when attempting to restart (this could take up to 5 minutes).
- Expansion and contraction of cooling coils during and after defrost can cause a cracking or popping sound.
- On models with an ice maker, after an ice making cycle, you may hear the ice cubes dropping into the ice bucket.



WATER SOUNDS

- The flow of refrigerant through the freezer cooling coils may make a gurgling noise like boiling water.
- Water dropping on the defrost heater can cause a sizzling, popping or buzzing sound during the defrost cycle.
- A water dripping noise may occur during the defrost cycle as ice melts from the evaporator and flows into the drain pan.
- Closing the door may cause a gurgling sound due to pressure equalization.

Troubleshooting Tips... Before you call for service

Save time and money! Review the charts on the following pages first and you may not need to call for service. If needed, service can be scheduled by visiting us online GEAppliances.com or calling 800.GECARES 800.432.2737. In Canada visit GEAppliances.ca or call 800.561.3344.

Problem	Possible Causes	What to Do
Refrigerator does not operate	Refrigerator in defrost cycle.	Wait about 30 minutes for defrost cycle to end.
	Either or both controls set to OFF	Set the controls to a lower temperature setting.
	Refrigerator is unplugged.	Push the plug completely into the outlet.
	The fuse is blown/circuit breaker is tripped.	Replace fuse or reset the breaker.
Motor operates for long periods or cycles on and off frequently. (Modern refrigerators with more storage space and a larger freezer require more operating time. They start and stop often to maintain even temperatures.)	Normal when refrigerator is first plugged in.	Wait 24 hours for the refrigerator to completely cool down.
	Often occurs when large amounts of food are placed in refrigerator.	This is normal.
	Door left open.	Check to see if package is holding door open.
	Hot weather or frequent door openings.	This is normal.
	Temperature controls set at the coldest setting.	See Temperature Control section.
Refrigerator or freezer compartment too warm	Temperature control not set cold enough.	See Temperature Control section.
	Warm weather or frequent door openings.	Set the temperature control one step colder. See Temperature Control section.
	Door left open.	Check to see if package is holding door open.
Frost or ice crystals on frozen food (frost within package is normal)	Door left open.	Check to see if package is holding door open.
	Too frequent or too long door openings.	This is normal.
Divider between refrigerator and freezer compartments feels warm.	Automatic energy saver system circulates warm liquid around the front edge of the freezer compartment.	This helps prevent condensation on the outside.
Automatic ice maker does not work (if installed).	Ice maker power switch is in the OFF position.	Set the power switch to ON position.
	Water supply turned off or not connected.	See Installing the water line section of the ice maker installation instructions.
	Freezer compartment too warm.	Wait 24 hours for the refrigerator to completely cool down.
	Piled up cubes in the storage bin cause the ice maker to shut off.	Level cubes by hand.
	Ice cubes stuck in ice maker.	Turn off the ice maker, remove cubes, and turn the ice maker back on.
Ice cubes have bad odor/taste	Ice storage bin needs cleaning.	Empty and wash bin. Discard old ice.
	Food transmitting odor/taste to ice	Wrap foods well.
	Interior of refrigerator needs cleaning.	See Care and Cleaning section.
Slow ice cube freezing	Door left open.	Check to see if package is holding door open.

Troubleshooting Tips... Before you call for service

Problem	Possible Causes	What to Do
Frequent buzzing sound from the ice maker (if installed).	Ice maker power switch is in the ON position but the water supply to the refrigerator has not been connected.	Set the power switch to the OFF position. Keeping it in the ON position will damage the water valve.
No ice cube production (if ice maker is installed).	Supply line or shutoff valve is clogged.	Call a plumber.
Refrigerator has odor.	Foods transmitting odor to refrigerator.	Foods with strong odors should be tightly wrapped. Keep an open box of baking soda in the refrigerator; replace every 3 months.
	Interior needs cleaning.	See Care and Cleaning section.
Moisture forms on outside of refrigerator.	Not unusual during periods of high humidity.	Wipe surface dry.
Moisture collects inside (in humid weather, air carries moisture into refrigerator when doors are opened)	Due to the higher humidity in the refrigerator, you may on occasion experience fog or small amounts of moisture in the refrigerator compartment.	This is normal and may come and go as different food loads and environmental conditions change. Wipe dry with a paper towel if desired.
Interior light does not work	No power at the outlet.	Replace fuse or reset the breaker.
	Light bulb is burned out.	See Care and Cleaning section.
Hot air from the bottom of the refrigerator	Normal air flow cooling motor. In the refrigeration process, it is normal that heat be expelled in the area under the refrigerator. Some floor coverings are sensitive and will discolor at these normal and safe temperatures.	This is normal.
Refrigerator never shuts off but the temperatures are ok.	Adaptive defrost keeps compressor running during door openings.	This is normal. The refrigerator will cycle off after the door remains closed for 2 hours.
Door not closing properly.	Door gasket on hinge side sticking or folding over.	Apply paraffin wax to the face of the gasket.
Door does not close by itself	Leveling legs need adjusting.	See Rollers and Leveling Legs in the Installation instructions section.
Freezer door opens when refrigerator door is closed.	This is normal if the door closes after it pops open.	This indicates that there is a good seal on the freezer door. If the freezer door does not automatically close after popping open, then see Door does not close by itself , above.
Food freezing in the refrigerator.	Food too close to the air vent at the back of the refrigerator.	Move food away from the air vent.
	Refrigerator control is set too cold.	Move the refrigerator control to a warmer temperature.
Handle is loose/handle has a gap.	Handle needs to be adjusted.	See Reversing Door Handles in the Installation Instructions section.

Refrigerator Limited Warranty

For US Customers, all warranty service provided by our Factory Service Centers, or an authorized Customer Care® technician. To schedule service, on-line, 24 hours a day, visit us at **GEAppliances.com**, or call 800.GE.CARES (800.432.2737). Please have serial number and model number available when calling for service.

In Canada, call 800.561.3344.

For the Period of:	GE Appliances Will Replace
One Year From the date of the original purchase	Any part of the refrigerator which fails due to a defect in materials or workmanship. During the limited one-year warranty , GE Appliances will also provide, free of charge , all labor and related service to replace the defective part.

What is Not Covered:

- Service trips to your home to teach you how to use the product.
- Improper installation, delivery or maintenance.
- Failure of the product if it is abused, misused, or used for other than the intended purpose or used commercially.
- Loss of food due to spoilage.
- Replacement of house fuses or resetting of circuit breakers.
- Damage caused after delivery.
- Replacement of the water filter cartridge, if included, due to water pressure that is outside the specified operating range or due to excessive sediment in the water supply.
- Replacement of the light bulbs, if included, or water filter cartridge, if included, other than as noted above.
- Damage to the product caused by accident, fire, floods or acts of God.
- Incidental or consequential damage caused by possible defects with this appliance.
- Product not accessible to provide required service.
- Damage caused by a non-GE Appliances Brand water filter.
- Damage to finish, such as surface rust, tarnish, or small blemishes not reported within 48 hours of delivery.
- Products which are not defective, broken, or which are working as described in the owner's manual.

EXCLUSION OF IMPLIED WARRANTIES—Your sole and exclusive remedy is product repair as provided in this Limited Warranty. Any implied warranties, including the implied warranties of merchantability or fitness for a particular purpose, are limited to one year or the shortest period allowed by law.

For US Customers: This limited warranty is extended to the original purchaser and any succeeding owner for products purchased for home use within the USA. If the product is located in an area where service by a GE Appliances Authorized Servicer is not available, you may be responsible for a trip charge or you may be required to bring the product to an Authorized GE Appliances Service location for service. In Alaska, the limited warranty excludes the cost of shipping or service calls to your home.

Some states do not allow the exclusion or limitation of incidental or consequential damages. This limited warranty gives you specific legal rights, and you may also have other rights which vary from state to state. To know what your legal rights are, consult your local or state consumer affairs office or your state's Attorney General.

Warrantor US: GE Appliances, a Haier company
 Louisville, KY 40225

For Customers in Canada: This limited warranty is extended to the original purchaser and any succeeding owner for products purchased in Canada for home use within Canada. In-home warrant service will be provided in areas where it is available and deemed reasonable by Mabe to provide.

Warrantor Canada: MC Commercial, Burlington, Ontario, L7R 5B6

Staple your receipt here. Proof of the original purchase date is needed to obtain service under the warranty.

Accessory

Icemaker Accessory Kit IM4D:

An IM4D icemaker accessory kit is available at extra cost.

To order, call GE Appliances at 800.GECARES (800.432.2737) or visit **GEAppliances.com**. In Canada, visit **GEAppliances.ca** or call 800.561.3344.

Follow the installation instructions on the following pages. You will use these instead of the instructions that come with your icemaker.

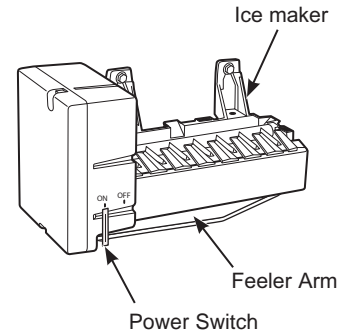

About the IM4D Icemaker

⚠ CAUTION

Do not place fingers or hands in the automatic icemaking mechanism while the refrigerator is plugged in. This will help protect you from possible injury.

It will also prevent interference with moving parts of the ejector mechanism and the heating element that releases the cubes, located on the bottom of the icemaker.

The icemaker will produce seven cubes per cycle—approximately 70-100 cubes in a 24-hour period, depending on freezer compartment temperature, room temperature, number of door openings and other use conditions.

If the refrigerator is operated before the water connection is made to the icemaker, set the power switch to **OFF**.

When the refrigerator has been connected to the water supply, set the power switch to **ON**.

The icemaker will fill with water when it cools to freezing. A newly-installed refrigerator may take 12 to 24 hours to begin making ice cubes.

You will hear a buzzing sound each time the icemaker fills with water.

Throw away the first few batches of ice to allow the water line to clear.

Be sure nothing interferes with the sweep of the feeler arm.

When the bin fills to the level of the feeler arm, the icemaker will stop producing ice.

It is normal for several cubes to be joined together.

If ice is not used frequently, old ice cubes will become cloudy, taste stale and shrink.

Preparing for Vacation

Set the icemaker power switch to **OFF** and shut off the water supply to the refrigerator.

If the temperature can drop below freezing, have a qualified servicer drain the water supply system (on some models) to prevent serious property damage due to flooding.

When you should set the icemaker power switch to OFF

- When the ice storage bin is removed for more than a minute or two.
- When the water supply will be shut off for several hours.
- When the refrigerator will not be used for several days.

Accessory Installation Instructions

If you have questions, call GE Appliances at **1.800.GE.CARES** or visit our Website at: **GEAppliances.com**. In Canada, call **1.800.561.3344** or visit our Website at: **geappliances.ca**

BEFORE YOU BEGIN







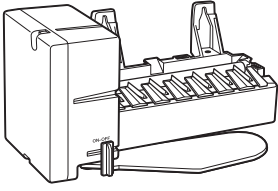
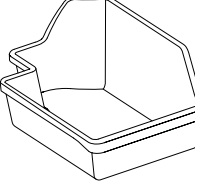

Read these instructions completely and carefully.

- **IMPORTANT** – Save these instructions for local inspector's use.
- **IMPORTANT** – Observe all governing codes and ordinances.
- **Note to Installer** – Be sure to leave these instructions with the Consumer.
- **Note to Consumer** – Keep these instructions for future reference.
- **Skill level** – Installation of this appliance requires basic mechanical skills.
- **Completion time** – 20–60 minutes
- Proper installation is the responsibility of the installer.
- Product failure due to improper installation is not covered under the Warranty.

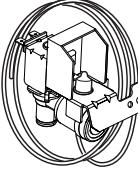
Damage – Shipment/Installation

- If the unit is damaged in shipment, return the unit to the store in which it was bought for repair or replacement.
- If the unit is damaged by the customer, repair or replacement is the responsibility of the customer.
- If the unit is damaged by the installer (if other than the customer), repair or replacement must be made by arrangement between customer and installer.

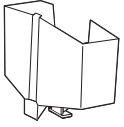
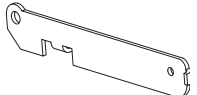
ITEMS NEEDED FROM IM4D KIT

- 
- 
- 
- 
- 
- 
- 
- 
- 
- 
- 
- 1 Icemaker
 - 2 Installation Instructions
 - 3 Water Valve and Tube Assembly
 - 4 Ice Bucket
 - 5 Hex-Head Screw for Water Line Clamp (3/4")*
 - 6 Water Line Clamp (strain relief), for house water line
 - 7 Warranty Label
 - 8 Ice Bucket
 - 9 Phillips Head Screws, for mounting icemaker (2) (7/8")*
 - 10 Phillips Head Screws, for mounting icemaker (2) (7/8")*
 - 11 Icemaker Fill Cup (side-mounted)
 - 12 Icemaker Fill Cup (side-mounted)
 - 13 Icemaker Fill Cup (side-mounted)
 - 14 Bracket Extension
 - 15 Bracket Extension
 - 16 Bracket Extension
 - 17 Hex-Head Screws, for bracket extension (1) (1/4")*

Accessory Installation Instructions

INSTALLING IM4D ICEMAKER KIT

BEFORE YOU BEGIN

Read these instructions completely and carefully.

⚠ WARNING  **ELECTRICAL SHOCK HAZARD** To eliminate the risk of electric shock or injury during installation, you must first unplug the refrigerator before proceeding.



YOU WILL NEED



Flat blade and Phillips screwdrivers



Pliers



Sharp knife

PREPARE THE REFRIGERATOR

Inside of the freezer, remove the cover for the icemaker power supply socket.

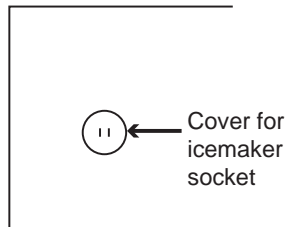

SET POWER SWITCH TO OFF

Set the icemaker power switch to **OFF**.

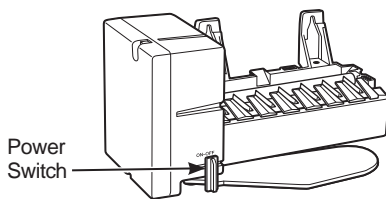

(Appearance may vary)

INSTALL THE ICEMAKER FILL CUP

Install the **icemaker fill cup** (13) into the icemaker as shown.

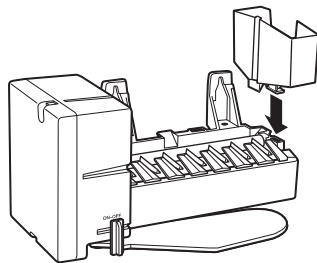

PLUG IN THE ICEMAKER

Plug the icemaker power cord into the socket making sure the prongs and holes are matched. Press the plug firmly into the socket. Lock the plug in place by clipping the restraints into each side of the plug. Make sure the restraints click into place. Make sure the power cord is still in the hook on back of the icemaker.

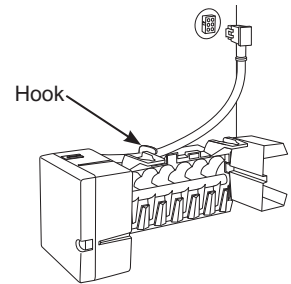

MOUNT THE ICEMAKER

- For easy installation, remove the upper freezer basket.
- Drive a mounting screw halfway into inside screw hole on the support bracket of the left side upper wall in the freezer. Lift the icemaker so the fill tube assembly fits in the fill cup opening. Hang the icemaker on the screw and on the L-shaped tab in front of the supporting bracket. Then drive the second mounting screw into the support bracket.

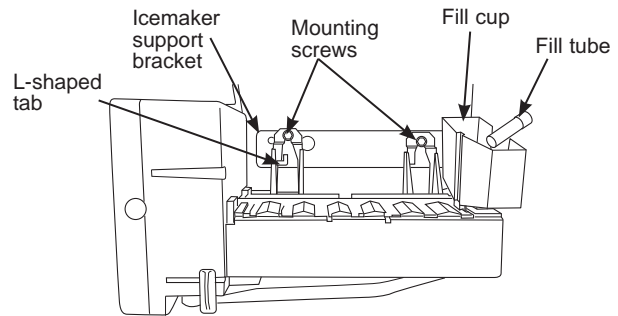

Make sure:

- The **power cord is still firmly in the socket.**
- The **fill tube assembly** extends into the fill cup opening at the back of the icemaker. (Check the rear of the refrigerator to make sure the fill tube has not been pushed out of the back of the refrigerator).
- The icemaker mounting screws should be located in the uppermost position of the mounting slots on the icemaker bracket.
- The icemaker is level.
- The icemaker power switch is in the **OFF** position.

SECURELY TIGHTEN THE ICEMAKER MOUNTING SCREWS.

Accessory Installation Instructions

INSTALLING ICEMAKER IM4D (CONT.)

INSTALL THE ICE BUCKET

- Remove the middle divider from the top freezer drawer.

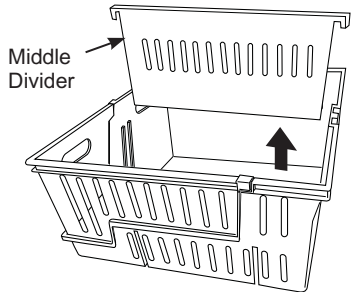

- Remove the L-shaped insert by unscrewing the 3 screws on each end. Insert the "buttons" provided into the holes in the ice bucket.

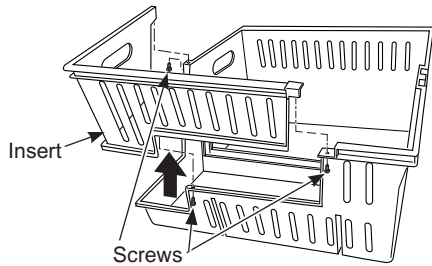

- Install the middle divider into the right slot.

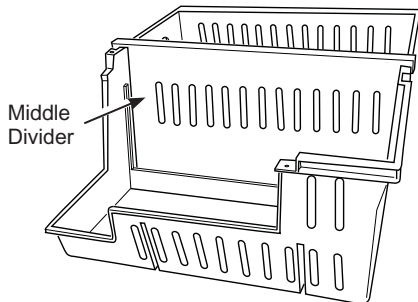

- Place the ice bucket on the 2 bottom ribs in the left side of the drawer.

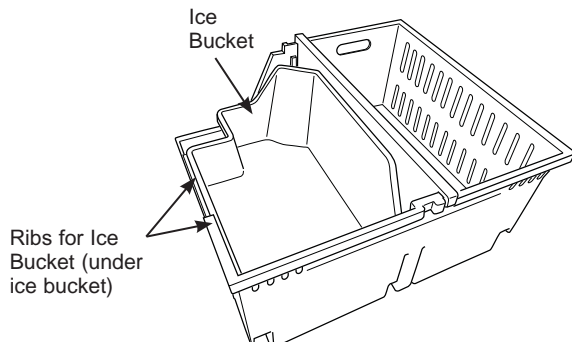

ATTACH WARRANTY LABEL

A **label** is provided with this kit to record the date of installation for warranty purposes. Apply it to the back of the refrigerator.

KEEP THE MANUAL

The warranty for the icemaker is printed in the manual that came with your icemaker kit. **Keep this manual with your Refrigerator Owner's Manual.**

The icemaker installation inside the freezer is now complete. Continue to the **Water Valve Assembly** section.

CAUTION

Do not place fingers or hands in the automatic icemaking mechanism while the refrigerator is plugged in. This will help protect you from possible injury.

It will also prevent interference with moving parts of the ejector mechanism and the heating element that releases the cubes, located on the bottom of the icemaker.

Accessory Installation Instructions

WATER VALVE ASSEMBLY

▲ WARNING To reduce the risk of death or electric shock, you must follow these instructions:

- Unplug the refrigerator before removing any panels.
- Do not contact or damage any wiring while the panel is removed.
- Replace all parts and panels before plugging the refrigerator back in.

REMOVE THE COVER

Remove the compressor compartment access cover. This requires removing Phillips head screws which attach the cover to the back of the refrigerator case. Be sure to save the screws as the access cover must be reinstalled later to ensure your refrigerator will function properly.

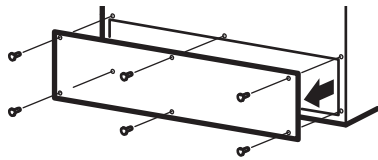

ATTACH THE WATER VALVE

- Use pre-installed water tube to connect to water valve. Do not use the water tube that came with the water valve. To remove the water tube from the water valve, push the white washer towards the water valve and pull out the water tube.
- Pull out the black water tube from right side of machine compartment. Remove the tape from the end or if you can not remove the tape completely, cut the end at 0.5". Make sure that you cut it straight. Make a mark at 0.5" from the cut end. Insert the water tube to the water valve all the way to the mark 0.5" from the end. Loop and tuck the rest of tube back to compartment.
- Locate the female connector plug. Plug the **female connector** onto the **male terminals** on the **water valve**. Either wire can go on either terminal.
- Fasten the water valve to the cabinet by driving one of access cover screw into the hole in the cabinet leg.

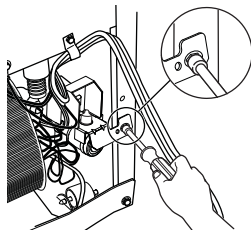
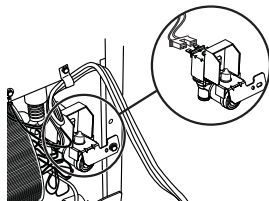

ATTACH THE WATER VALVE (Cont.)

- Open the outlet box cover, located on the right side of the back of the unit, with flat head screw driver.
- Check the water line connection. Make sure the water tube is fully inserted into the grommet. If not, loosen the hose clamp by squeezing the ends with pliers and insert the tube as far as it can go. Then release the clamp ends and make sure that the clamp captures the water tube. Otherwise, water may leak from this connection.

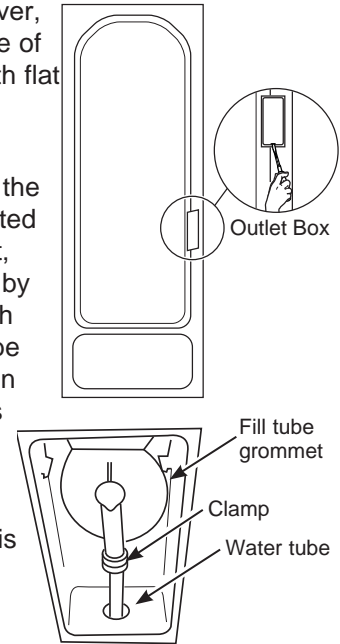

Accessory Installation Instructions

INSTALLING THE WATER LINE

BEFORE YOU BEGIN

Recommended copper water supply kits are WX8X2, WX8X3 or WX8X4, depending on the amount of tubing you need. Approved plastic water supply lines are SmartConnect™ Refrigerator Tubing (WX08X10002, WX08X10006, WX08X10015 and WX08X10025).

When connecting your refrigerator to a GE Appliances Reverse Osmosis Water System, the only approved installation is with a GE Appliances RVKit. For other reverse osmosis water systems, follow the manufacturer's recommendations.

If the water supply to the refrigerator is from a Reverse Osmosis Water Filtration System AND the refrigerator also has a water filter, use the refrigerator's filter bypass plug. Using the refrigerator's water filtration cartridge in conjunction with the RO filter can result in hollow ice cubes and slower water flow from the water dispenser.

This water line installation is not warranted by the refrigerator or icemaker manufacturer. Follow these instructions carefully to minimize the risk of expensive water damage.

Water hammer (water banging in the pipes) in house plumbing can cause damage to refrigerator parts and lead to water leakage or flooding. Call a qualified plumber to correct water hammer before installing the water supply line to the refrigerator.

To prevent burns and product damage, do not hook up the water line to the hot water line.

If you use your refrigerator before connecting the water line, make sure the icemaker power switch is in the **OFF** position.

Do not install the icemaker tubing in areas where temperatures fall below freezing.

When using any electrical device (such as a power drill) during installation, be sure the device is double insulated or grounded in a manner to prevent the hazard of electric shock, or is battery powered.

All installations must be in accordance with local plumbing code requirements.

⚠ WARNING

Connect to potable water supply only.

A cold water supply is required for automatic icemaker operation. The water pressure must be between 40 and 120 psi (275-827 kilopascals)

WHAT YOU WILL NEED

- Copper or SmartConnect™ Refrigerator Tubing kit, 1/4" outer diameter to connect the refrigerator to the water supply. If using copper, be sure both ends of the tubing are cut square.

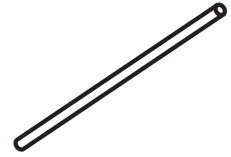

To determine how much tubing you need: measure the distance from the water valve on the back of the refrigerator to the water supply pipe. Then add 8 feet (2.4 m). Be sure there is sufficient extra tubing (about 8 feet [2.4 m] coiled into 3 turns of about 10" [25 cm] diameter) to allow the refrigerator to move out from the wall after installation.

SmartConnect™ Refrigerator Tubing Kits are available in the following lengths:

2' (.6 m) – WX08X10002

8' (2.4 m) – WX08X10006

15' (4.6 m) – WX08X10015

25' (7.6 m) – WX08X10025

Be sure that the kit you select allows at least 8 feet (2.4 m) as described above.

NOTE: The only GE Appliances approved plastic tubing is that supplied in SmartConnect™ Refrigerator Tubing kits. Do not use any other plastic water supply line because the line is under pressure at all times. Certain types of plastic will crack or rupture with age and cause water damage to your home.

- A **GE Appliances water supply kit** (containing tubing, shutoff valve and fittings listed below) is available at extra cost from your dealer or from Parts and Accessories, 877.959.8688.
- A **cold water supply**. The water pressure must be between 20 and 120 p.s.i. (1.4–8.2 bar) on models without a water filter and between 40 and 120 p.s.i. (2.8–8.2 bar) on models with a water filter.

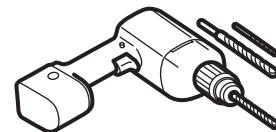

- Power drill.
- 1/2" or adjustable wrench.
- Straight and Phillips blade screwdriver.

Accessory Installation Instructions

INSTALLING THE WATER LINE (Continued)

WHAT YOU WILL NEED (Continued)

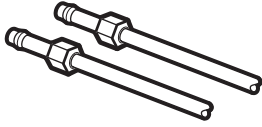

- Two 1/4" outer diameter compression nuts and 2 ferrules (sleeves)—to connect the copper tubing to the shutoff valve and the refrigerator water valve.

OR

- If you are using a SmartConnect™ Refrigerator Tubing kit, the necessary fittings are preassembled to the tubing.

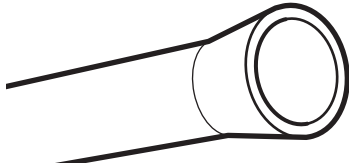

- If your existing copper water line has a flared fitting at the end, you will need an adapter (available at plumbing supply stores) to connect the water line to the refrigerator OR you can cut off the flared fitting with a tube cutter and then use a compression fitting. Do not cut formed end from SmartConnect™ Refrigerator tubing.

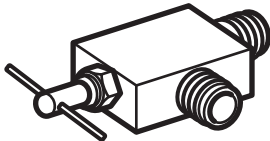

- Shutoff valve to connect to the cold water line. The shutoff valve should have a water inlet with a minimum inside diameter of 5/32" at the point of connection to the COLD WATER LINE. Saddle-type shutoff valves are included in many water supply kits. Before purchasing, make sure a saddle-type valve complies with your local plumbing codes.

Install the shutoff valve on the nearest frequently used drinking water line.

1 SHUT OFF THE MAIN WATER SUPPLY

Turn on the nearest faucet long enough to clear the line of water.

2 CHOOSE THE VALVE LOCATION

Choose a location for the valve that is easily accessible. It is best to connect into the side of a vertical water pipe. When it is necessary to connect into a horizontal water pipe, make the connection to the top or side, rather than at the bottom, to avoid drawing off any sediment from the water pipe.



3 CHOOSE THE VALVE LOCATION

Drill a 1/4" hole in the water pipe (even if using a self-piercing valve) using a sharp bit. Remove any burrs resulting from drilling the hole in the pipe. **Take care not to allow water to drain into the drill.** Failure to drill a 1/4" hole may result in reduced ice production or smaller cubes.

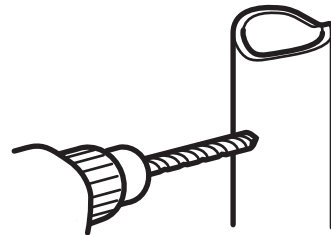

4 FASTEN THE SHUTOFF VALVE

Fasten the shutoff valve to the cold water pipe with the pipe clamp.

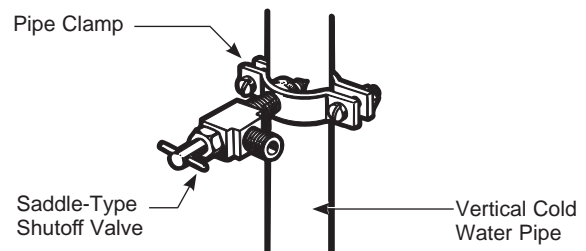

NOTE: Commonwealth of Massachusetts Plumbing Codes 248CMR shall be adhered to. Saddle valves are illegal and use is not permitted in Massachusetts. Consult with your licensed plumber.

Accessory Installation Instructions

INSTALLING THE WATER LINE (Continued)

5 TIGHTEN THE PIPE CLAMP

Tighten the clamp screws until the sealing washer begins to swell.

NOTE: Do not overtighten or you may crush the tubing.

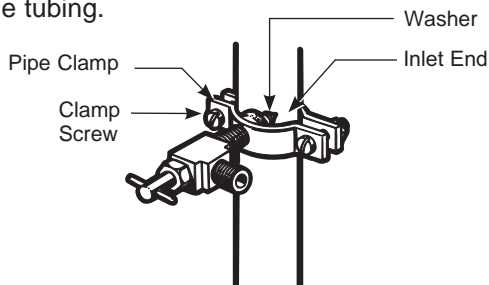

NOTE: Commonwealth of Massachusetts Plumbing Codes 248CMR shall be adhered to. Saddle valves are illegal and use is not permitted in Massachusetts. Consult with your licensed plumber.

6 ROUTE THE TUBING

Route the tubing between the cold water line and the refrigerator.

Route the tubing through a hole drilled in the wall or floor (behind the refrigerator or adjacent base cabinet) as close to the wall as possible.

NOTE: Be sure there is sufficient extra tubing (about 8 feet [244 cm] coiled into 3 turns of about 10" [25 cm] diameter) to allow the refrigerator to move out from the wall after installation.

7 CONNECT THE TUBING TO THE VALVE

Place the compression nut and ferrule (sleeve) for copper tubing onto the end of the tubing and connect it to the shutoff valve.

Make sure the tubing is fully inserted into the valve. Tighten the compression nut securely.

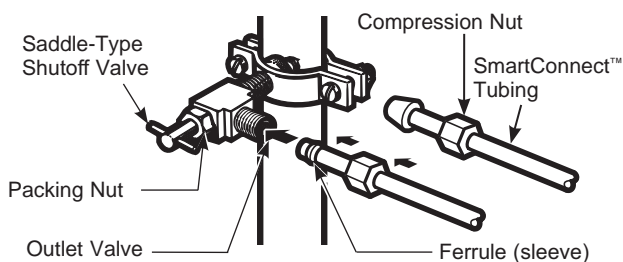

7 CONNECT THE TUBING TO THE VALVE (Continued)

For plastic tubing from a SmartConnect™ Refrigerator Tubing kit, insert the molded end of the tubing into the shutoff valve and tighten compression nut until it is hand tight, then tighten one additional turn with a wrench. Overtightening may cause leaks.

8 FLUSH OUT THE TUBING

Turn the main water supply on and flush out the tubing until the water is clear.

Shut the water off at the water valve after about one quart (1 liter) of water has been flushed through the tubing.



9 CONNECT THE TUBING TO THE REFRIGERATOR

NOTES:

- Before making the connection to the refrigerator, be sure the refrigerator power cord is not plugged into the wall outlet.
- If your refrigerator does not have a water filter, we recommend installing one if your water supply has sand or particles that could clog the screen of the refrigerator's water valve. Install it in the water line near the refrigerator. If using SmartConnect™ Refrigerator Tubing kit, you will need an additional tube (WX08X10002) to connect the filter. Do not cut plastic tube to install filter.

Remove the plastic flexible cap from the water valve (refrigerator connection).

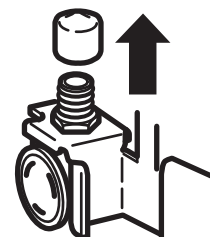

Accessory Installation Instructions

INSTALLING THE WATER LINE (Continued)

9 CONNECT THE TUBING TO THE REFRIGERATOR (Continued)

Place the compression nut and ferrule (sleeve) onto the end of the tubing as shown. On SmartConnect™ Refrigerator Tubing kit, the nuts are already assembled to the tubing.

Insert the end of the tubing into the water valve connection as far as possible. While holding the tubing, tighten the fitting.

For plastic tubing from a SmartConnect Refrigerator Tubing kit, insert the molded end of the tubing into the refrigerator connection and tighten compression nut until it is hand tight, then tighten one additional turn with a wrench. Overtightening may cause leaks.

Fasten the tubing into the clamp provided to hold it in a vertical position. You may need to pry open the clamp.

⚠ WARNING  **ELECTRIC SHOCK HAZARD**

Attach tubing clamp using existing hole only. DO NOT drill into the refrigerator.

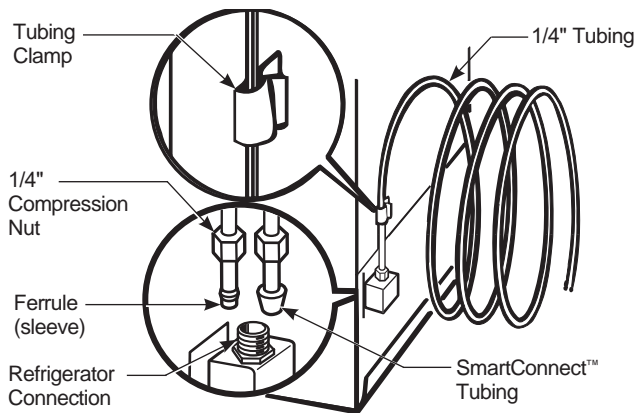

10 TURN THE WATER ON AT THE SHUTOFF VALVE

Tighten any connections that leak.

Reattach the compressor compartment access cover.

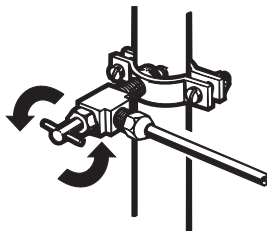

11 REINSTALL THE COVER

Reinstall the compressor compartment access cover. This requires using the screws you removed previously to reattach the cover to the back of the refrigerator case.

This must be reinstalled for your refrigerator to function properly. The water line should come out at the water relief slot at the right side, above the power line.

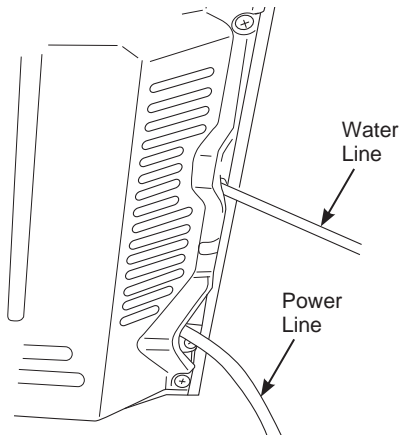

12 PLUG IN THE REFRIGERATOR

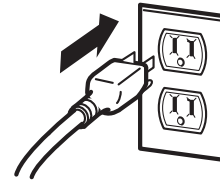

Arrange the coil of tubing so that it does not vibrate against the back of the refrigerator or against the wall. Push the refrigerator back to the wall.

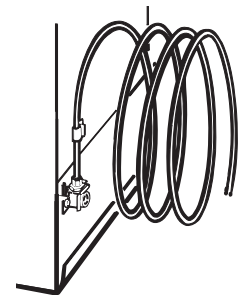

13 START THE ICEMAKER

Set the icemaker power switch to the ON position. The icemaker will not begin to operate until it reaches its operating temperature of 15°F (–9°C) or below. It will then begin operation automatically if the icemaker power switch is in the ON position.

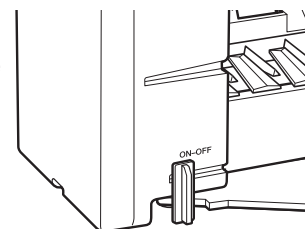

Accessory Installation Instructions

Troubleshooting Tips... Before you call for service

Save time and money! Review the charts on the following pages first and you may not need to call for service. If needed, service can be scheduled by visiting us online GEAppliances.com or calling 800.GECARES 800.432.2737. In Canada visit GEAppliances.ca or call 800.561.3344.

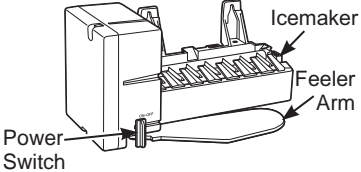
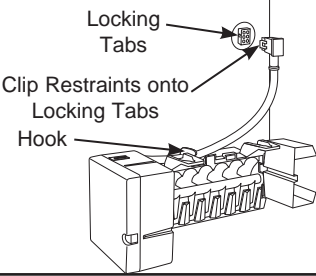
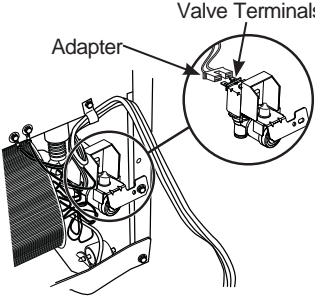
Problem	Possible Causes	What to Do
Automatic icemaker does not work	Freezer compartment too warm.	After installing the kit, allow the refrigerator to completely cool down for 24 hours. Once the compartment is cool, the icemaker will begin ice production.
	Icemaker is not turned on.	Move the icemaker power switch to the ON position.  The diagram shows a side view of the icemaker unit. A label 'Power Switch' points to a small rectangular switch on the left side of the unit. Other labels include 'Icemaker' pointing to the main body and 'Feeler Arm' pointing to a curved arm on the right side.
	Icemaker is not plugged in correctly.	Check that the icemaker cord plug is fully inserted into the socket. See "Plug in the icemaker" in the Installation Instructions.  The diagram shows the icemaker cord plug being inserted into a power outlet. Labels include 'Locking Tabs' pointing to the top of the plug, 'Clip Restraints onto Locking Tabs' pointing to the top of the outlet, and 'Hook' pointing to the bottom of the plug.
	Water line kinked.	Check that the plastic water line running from the valve to the water tube inlet is not kinked. See "Connect the water line" in the Installation Instructions. A kink in the water line will restrict flow to the water line.
	Water supply turned off or not connected.	After installing the kit, make sure the house water supply to the refrigerator has been turned on.
	Piled up cubes in the storage bin cause the icemaker to shut off.	Level cubes by hand.
	Water valve is not plugged in correctly.	Check that the valve wire adapter is completely plugged onto the terminals on the water valve. See "Attach the water valve" in the Installation Instructions.  The diagram shows a close-up of the valve wire adapter being plugged into the terminals of a water valve. Labels include 'Adapter' pointing to the wire harness and 'Valve Terminals' pointing to the electrical contacts on the valve.

Accessory Installation Instructions

Troubleshooting Tips... Before you call for service

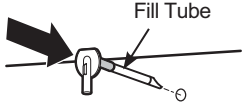
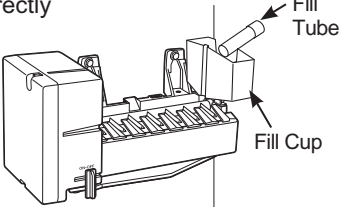
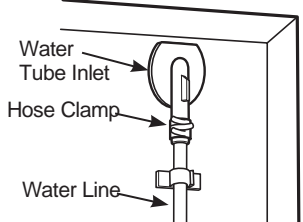
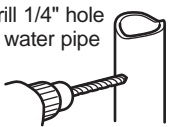
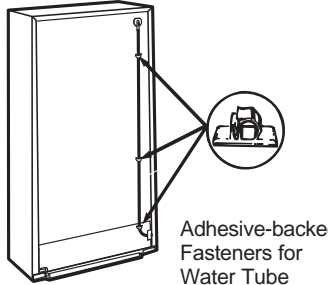
Problem	Possible Causes	What to Do
Leaking water around the fill cup	Foam in the fill cup from installing the fill tube.	If the fill tube was installed by sliding it through the back of the refrigerator, it may have picked up pieces of foam as it was pushed through. This foam can interfere with the water flow in the fill cup. Check the cup and make sure there are no foam pieces. 
	Fill tube not correctly seated in the fill cup.	Check that the fill tube is correctly inserted in the fill cup opening. See "Mount the icemaker" in the Installation Instructions. 
Leaking water behind the refrigerator	House supply not properly connected to the water valve.	Check that the house supply is firmly attached to the water valve. See Water line installation instructions.
	Water line not connected to the water tube inlet.	Check that the plastic water line running from the valve to the water tube inlet is firmly attached with the water line. 
Slow ice/freezer not cold enough	Door left open.	Check to see if package is holding door open.
	Temperature control not set cold enough.	See Controls on page 5.
Ice cubes too small/ slow ice	Water shutoff valve connecting refrigerator to house water line may be clogged.	We recommend drilling a 1/4" hole in the water pipe to connect the water shut-off valve. Failure to drill a 1/4" hole may result in reduced ice production or smaller cubes. See Installing the water line. 
	Water line kinked.	Check that the plastic water line running from the valve to the water tube inlet is not kinked. See "Connect the water line" in the Installation Instructions. A kink in the water line will restrict flow to the icemaker. 
Ice cubes not landing in bucket	Icemaker cord causing icemaker/ bucket misalignment	Be sure icemaker power cord is in the hook as stated in the Installation Instructions.
Ice cubes have odor/taste	Ice storage bin needs cleaning.	Empty and wash bin. Discard old cubes.
	Food transmitting odor/taste to ice cubes.	Wrap foods well.
	Interior of refrigerator needs cleaning.	See "Care and cleaning" in the Owner's Manual of the refrigerator.
Frequent "buzzing" sound	Normal operation.	During normal operation, the water valve will "buzz" when the icemaker fills with water.

Consumer Support

GE Appliances Website

Have a question or need assistance with your appliance? Try the GE Appliances Website 24 hours a day, any day of the year! You can also shop for more great GE Appliances products and take advantage of all our on-line support services designed for your convenience. In the US: GEAppliances.com In Canada: GEAppliances.ca

Register Your Appliance

Register your new appliance on-line at your convenience! Timely product registration will allow for enhanced communication and prompt service under the terms of your warranty, should the need arise. You may also mail in the pre-printed registration card included in the packing material.

In the US: GEAppliances.com/register

In the Canada: Prodsupport.mabe.ca/crm/Products/ProductRegistration.aspx

Schedule Service

Expert GE Appliances repair service is only one step away from your door. Get on-line and schedule your service at your convenience any day of the year. In the US: GEAppliances.com/service or call 800.432.2737 during normal business hours.

In Canada: GEAppliances.ca/en/support/service-request or call 800.561.3344

Extended Warranties

Purchase a GE Appliances extended warranty and learn about special discounts that are available while your warranty is still in effect. You can purchase it on-line anytime. GE Appliances Services will still be there after your warranty expires.

In the US: GEAppliances.com/extended-warranty or call 800.626.2224 during normal business hours.

In Canada: GEAppliances.ca/en/support/purchase-extended-warranty or call 800.290.9029

Remote Connectivity

For assistance with wireless network connectivity (for models with remote enable), visit our website at GEAppliances.com/connect or call 800.220.6899.

In Canada: GEAppliances.ca/connected-home-smart-appliances/ or call 800.220.6899.

Parts and Accessories

Individuals qualified to service their own appliances can have parts or accessories sent directly to their homes (VISA, MasterCard and Discover cards are accepted). Order on-line today 24 hours every day.

In the US: GEApplianceparts.com or by phone at 877.959.8688 during normal business hours.

Instructions contained in this manual cover procedures to be performed by any user. Other servicing generally should be referred to qualified service personnel. Caution must be exercised, since improper servicing may cause unsafe operation.

Customers in Canada should consult the yellow pages for the nearest Mabe service center, visit our website at GEAppliances.ca/en/products/parts-filters-accessories or call 800.661.1616.

Contact Us

If you are not satisfied with the service you receive from GE Appliances, contact us on our Website with all the details including your phone number, or write to:

In the US: General Manager, Customer Relations | GE Appliances, Appliance Park | Louisville, KY 40225

GEAppliances.com/contact

In Canada: Director, Consumer Relations, Mabe Canada Inc. | Suite 310, 1 Factory Lane | Moncton, N.B. E1C 9M3

GEAppliances.ca/en/contact-us