

- en **Operator's Manual** - Dual Stage Snowthrower
- es **Manual del operador** - Lanzanieve de dos etapas
- fr **Manuel de l'utilisateur** - Souffleuse à neige à deux phases

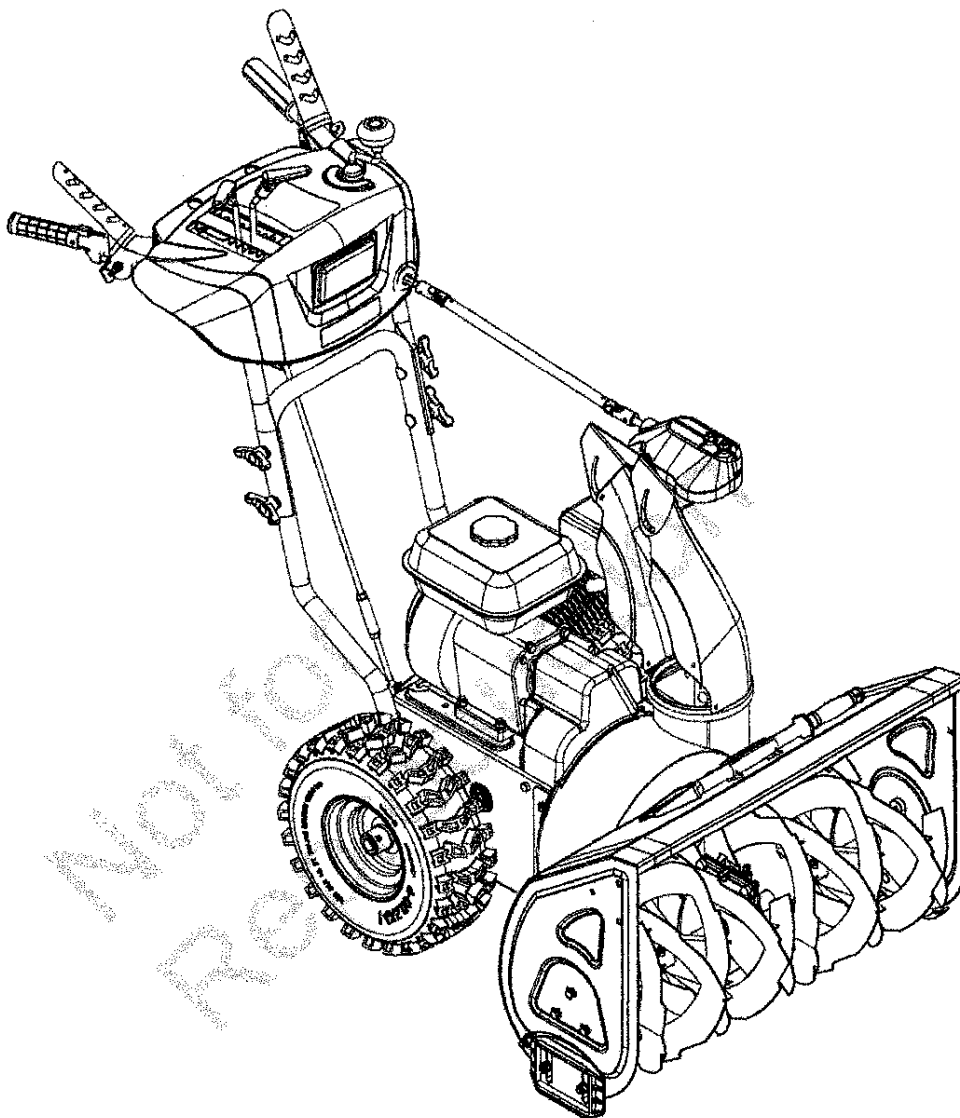

Manual Contents:

General Information.....	2
Operator Safety.....	2
Features and Controls.....	4
Operation.....	5
Maintenance and Adjustments.....	12
Storage.....	16
Troubleshooting.....	17
Specifications.....	18

General Information

For additional information, refer to the *Customer Contact Guide* included with the unit.

The illustrations in this document are representative. Your unit might look different from the images shown. *LEFT* and *RIGHT* are referenced from the operator's position.

The use of Important and Note in the text shows clarifications, exceptions, or alternatives to the procedures.

All language translations of this document derive from the initial English source file.



Recycle all packaging, used oil, and batteries according to applicable government regulations.

Operator Safety

Save these instructions

Save these instructions for future reference. This manual contains safety information to make you aware of the hazards and risks associated with the product and how to avoid them. It also contains important instructions that must be obeyed during the initial set-up, operation, and maintenance of the product.

The snowthrower is designed and intended only for snow removal from hard-surfaces, ground-level walkways, and driveways. It is not intended for any other purpose.

It is important that you read and understand these instructions before you attempt to start or operate this equipment.

Be thoroughly familiar with the controls and the correct use of the snowthrower.

Know how to stop the unit and disengage the controls quickly.

Safety Alert Symbol and Signal Words

The safety alert symbol  identifies safety information about hazards that can result in personal injury. A signal word (**DANGER**, **WARNING**, or **CAUTION**) is used with the alert symbol to indicate the likelihood and the potential severity of injury. In addition, a hazard symbol may be used to represent the type of hazard.

















 **DANGER** indicates a hazard which, if not avoided, will result in death or serious injury.

 **WARNING** indicates a hazard which, if not avoided, could result in death or serious injury.

 **CAUTION** indicates a hazard which, if not avoided, could result in minor or moderate injury.

NOTICE indicates information considered important but not hazard-related.

Snowthrower Hazard Symbols

	Safety information about hazards that can result in personal injury.		Read and understand the Operator's Manual before you operate or service the unit.
	Amputation hazard - rotating impeller.		Remove the key, and read the Operator's Manual before you service the unit.
	Amputation hazard - rotating impeller		Amputation hazard - rotating auger
	Amputation hazard - do not touch moving parts.		Thrown objects hazard
	Fire hazard		Explosion hazard
	Shock hazard		Toxic fume hazard
	Hot surface hazard		Kickback hazard
	Keep a safe distance		Keep children away
	Wear safety glasses	---	---

Safety Messages

WARNING

This product can expose you to chemicals including gasoline engine exhaust, which is known to the State of California to cause cancer and carbon monoxide, which is known to the State of California to cause birth defects or other reproductive harm. For more information go to www.P65Warnings.ca.go.

DANGER

This snowthrower is capable of amputating hands and feet, and throwing objects. Read and obey all the safety instructions in this manual. Failure to do so could result in death or serious injury.

Hand contact with the rotating auger inside the discharge chute is the most common cause of injury associated with snowthrowers.

WARNING

Read, understand, and obey all the instructions on the snowthrower and in the Operator's Manual before you operate this unit. Failure to obey the safety instructions in this manual could result in death or serious injury.

- Only let operators who are responsible, trained, familiar with the instructions and physically capable to operate the machine.

WARNING

Always wear safety glasses or eye shields during operation or while performing an adjustment or repair to protect eyes from foreign objects that may be thrown from the machine.



U.S.A. Models: It is a violation of California Public Resource Code Section 4442 to use or operate the engine on any forest-covered, brush-covered, or grass-covered land unless the exhaust system is equipped with a spark arrester, as defined in Section 4442, maintained in effective working order. Other states or federal jurisdictions may have similar laws. Contact the original equipment manufacturer, retailer, or dealer to obtain a spark arrester designed for the exhaust system installed on this engine.

Safety Decals

Before you operate the unit, read the safety decals. Compare Figure 1 to the decals shown in table that follows. The cautions and warnings are for your safety. To avoid personal injury or damage to the unit, understand and obey the safety decals.

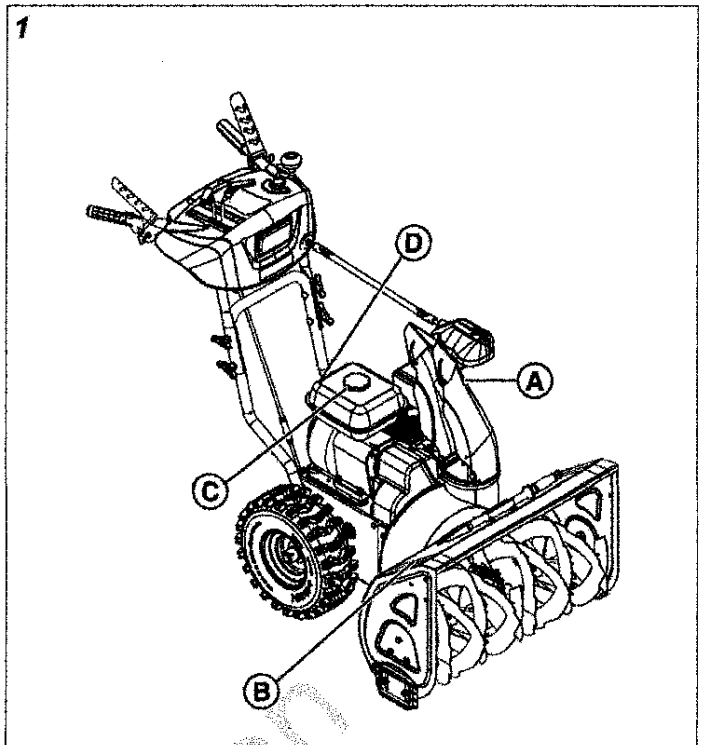
IMPORTANT: If the safety decals become worn or damaged, and cannot be read, order replacement decals from your local dealer.

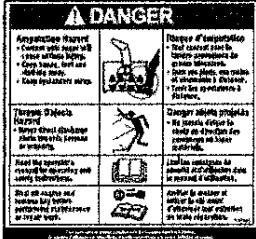

A	
B	
C	

WARNING / AVERTISSEMENT

 Read and follow Operating Instructions before running engine.

Lire et suivre le mode d'emploi avant de faire tourner le moteur.

 Gasoline is flammable. Allow engine to cool at least 2 minutes before refueling.

L'essence est inflammable. Laisser refroidir le moteur pendant au moins 2 minutes avant de faire le plein.

 Engines emit carbon monoxide, DO NOT run in enclosed area.

Les moteurs émettent du monoxyde de carbone. NE PAS faire tourner le moteur dans des espaces clos.

 Muffler area temperature may exceed 150°F. Do not touch hot parts.

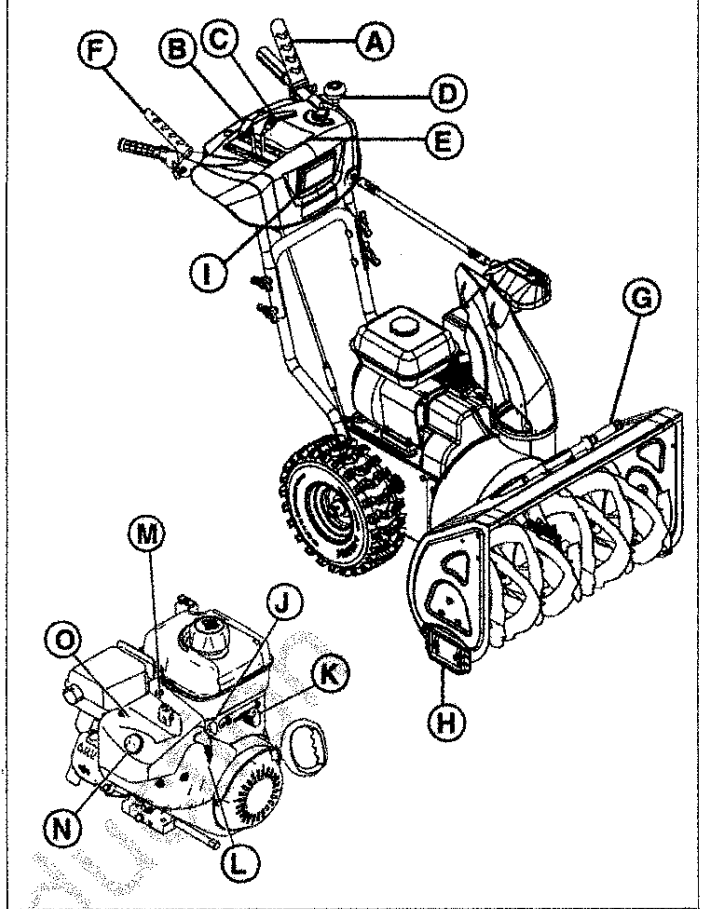

Autour du silencieux, la température peut dépasser 150° F. Ne pas toucher des pièces chaudes.









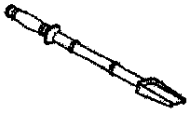
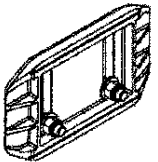
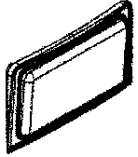

Features and Controls

Make sure that the callout letters in Figure 2 agree with the features and controls in the table that follows.

Control Symbols and Meanings

A		Auger Control Lever
B		Speed Selector Lever
C		Deflector Control - (In-Dash)
D		Chute Rotation Crank - (In-Dash)

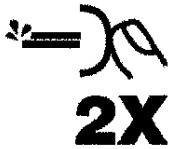
E		Free Hand™ Feature
F		Traction Control Lever
G		Clean-Out Tool
H		Skid Shoes
I		Headlight
J		Fuel Shut-Off Valve (if equipped)
K		Throttle Control (if equipped)
L		ON/OFF Switch
M		Choke CLOSED / Choke OPEN

N		Primer Button
O		Alternate Choke-Prime Instructions

Operation

WARNING

This snowthrower is only as safe as the operator. If it is misused, or not maintained correctly, it can be dangerous. Remember you are responsible for your safety and those around you.

- When leaving the operating position always disengage the auger, STOP the engine, and remove the key. DO NOT leave a running machine unattended.
- DO NOT operate the snowthrower without the correct guards, and other safety protective devices in place and working.
- Be careful when you operate the unit on gravel driveways, walkways, or roads. Stay alert for hidden hazards or traffic.
- DO NOT operate the snowthrower without good visibility or light. Always be sure of your footing, and keep a firm hold on the handles. Walk; never run.
- Be careful to avoid slipping or falling, especially when you operate the snowthrower in reverse.
- Be careful when you operate the snowthrower on slopes.
- If you strike a foreign object, stop the engine, remove the wire from the spark plug, thoroughly inspect the snowthrower for damage, and repair the damage before you start and operate the snowthrower.
- DO NOT operate the equipment without wearing adequate winter garments. Avoid loose fitting clothing that can get caught in moving parts. Wear footwear that will improve footing on slippery surfaces.
- DO NOT touch a hot muffler or engine. Let the muffler and engine cylinder to cool before touching.

Operating Area

1. Identify the walkways and driveways where you plan to operate the snowthrower.
2. Make sure that the area is free of debris or objects that the auger could pick-up and throw from the chute.

WARNING

This machine is capable of throwing objects that could injure bystanders or cause damage to buildings.

3. Before you start the engine, move the snowthrower outdoors and away from windows and doors.



WARNING

Engines give off carbon monoxide, an odorless, colorless, poison gas. Breathing carbon monoxide can cause nausea, fainting, or death.

- Start and operate the engine outdoors.
 - Do not operate the engine in an enclosed area, even if doors or windows are open.
4. Make sure that the operating area is clear of bystanders, especially children.



WARNING

This snowthrower is capable of amputating hands and feet, and throwing objects. Read and obey the safety instructions in this manual. Failure to do so could result in death or serious injury.

- Keep children out of the area during operation.
- Children are often attracted to the equipment. Be mindful of all persons present.
- Be alert and turn the unit off if bystanders enter the area.
- Use extra care when you approach blind corners, shrubs, trees, or other objects that can obscure vision.

Engine

Oil Recommendations

Oil Capacity: See the *Specifications* section.

NOTICE

This engine was shipped from Briggs & Stratton without oil. Equipment manufacturers or dealers may have added oil to the engine. Before you start the engine for the first time, make sure to check the oil level and add oil as specified by the instructions in this manual. If you start the engine without oil, it will be damaged beyond repair and will not be covered under warranty.

We recommend the use of Briggs & Stratton® Warranty Certified oils for best performance. Other high-quality detergent oils are permitted if classified for service SF, SG, SH, SJ or higher. Do not use special additives.

Outdoor temperatures determine the correct oil viscosity for the engine. Use the chart to select the best viscosity for the outdoor temperature range expected. Engines on most outdoor power equipment operate well with 5W-30 Synthetic oil. For equipment operated in hot temperatures, Vanguard® 15W-50 Synthetic oil gives the best protection.

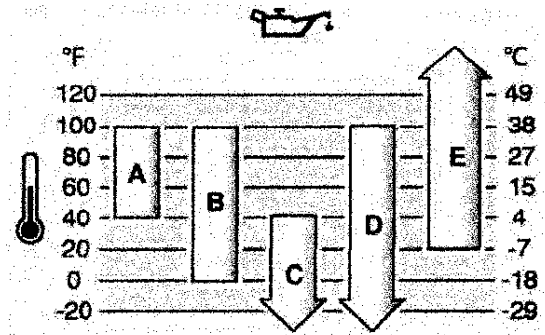

A	SAE 30 - Below 40 °F (4 °C) the use of SAE 30 will result in hard starting.
B	10W-30 - Above 80 °F (27 °C) the use of 10W-30 may cause increased oil consumption. Check the oil level frequently.
C	5W-30
D	Synthetic 5W-30
E	Vanguard® Synthetic 15W-50

Check and Add Oil

NOTICE

Some engines are shipped from Briggs & Stratton with or without oil. Always make sure that the engine has oil. If you start the engine without oil, it will be damaged beyond repair and will not be included under the warranty.

Use Briggs & Stratton® Synthetic 5W-30 Warranty Certified oil for best performance. Other high-quality detergent oils are permitted if classified for service SG, SH, SJ or higher. Do not use additives.

1. Put the unit on a level surface (Figure 3).

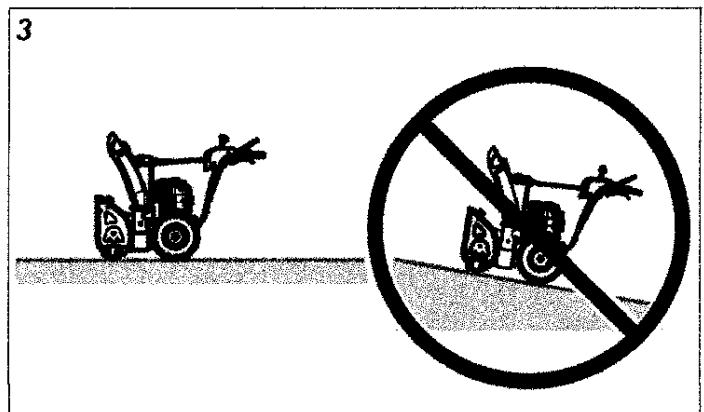

2. Clean the oil fill area.
3. Remove the dipstick (A, Figure 4). Use a clean cloth to remove oil from dipstick.
4. Install the dipstick, and check the oil level. Make sure that the oil level is at the top of the FULL indicator (C).
5. If the oil level is below the FULL indicator, carefully add oil into the engine oil fill tube (B). DO NOT add too much oil in the oil fill tube.
6. Wait one minute. Check the oil level again.

- When the oil level touches the top of the FULL indicator, install and tighten the dipstick.

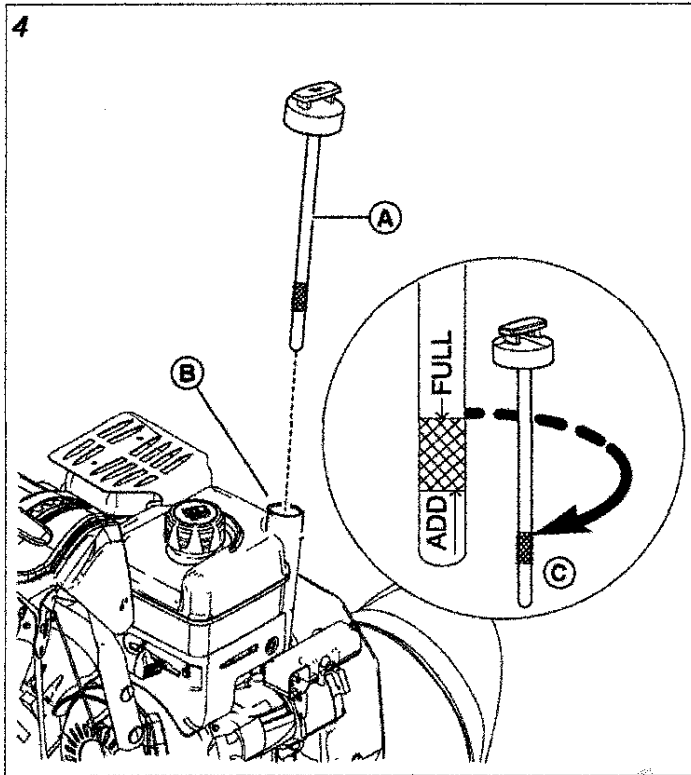

Fuel Recommendations

Fuel must meet these requirements:

- Clean, unleaded gasoline.
- A minimum of 87 octane / 87 AKI (91 RON). See *High Altitude Requirements*.
- Gasoline with up to 10% ethanol (gasohol).

NOTICE Do not use unapproved gasoline, such as E15 and E85. Do not mix oil in gasoline or change the engine to operate on alternative fuels. Use of unapproved fuels will cause damage to engine components, which will not be covered under the warranty.

To protect the fuel system from gum formation, mix a fuel stabilizer into the fuel. See *Storage*. All fuel is not the same. If start or performance problems occur, change fuel providers or change brands. This engine is certified to operate on gasoline. The emissions control system for this engine is EM (Engine Modifications).

High Altitude Requirements

- At altitudes over 5,000 feet (1,524 meters), a minimum 85 octane / 85 AKI (89 RON) gasoline is acceptable.
- For carbureted engines, high altitude adjustment is required to remain emissions compliant. Operation without this adjustment will cause decreased performance, increased fuel consumption, and increased emissions. Contact a Briggs & Stratton Authorized Service Dealer for high altitude adjustment information.

- Operation of the engine at altitudes below 2,500 feet (762 meters) with the high altitude adjustment is not recommended.
- For Electronic Fuel Injection (EFI) engines, high altitude adjustment is not necessary.

Add Fuel



Fuel and its vapors are extremely flammable and explosive. Always handle fuel with extreme care. Failure to obey these safety instructions can cause fire or explosion, which could result in severe burns or death.

When Adding Fuel

- Stop the engine and let the engine cool at least 3 minutes before you remove the fuel cap.
 - Extinguish cigarettes, cigars, pipes, and other sources of ignition.
 - Fill fuel tank outdoors or in well-ventilated area.
 - Do not overfill fuel tank. To allow for expansion of the fuel, do not fill above the bottom of the fuel tank neck.
 - Keep fuel away from sparks, open flames, pilot lights, heat, and other ignition sources.
 - Check fuel lines, tank, cap, and fittings frequently for cracks or leaks. Replace if necessary.
 - If fuel spills, wait until it evaporates before you start the engine. **DO NOT** create other ignition sources.
 - Use only an approved fuel container.
1. Remove unwanted material from the fuel cap area.
 2. Remove the fuel cap (A, Figure 5).
 3. Fill the fuel tank (B) with fuel. **DO NOT** fill above the bottom of the fuel tank neck (C).
 4. Install the fuel cap.

5

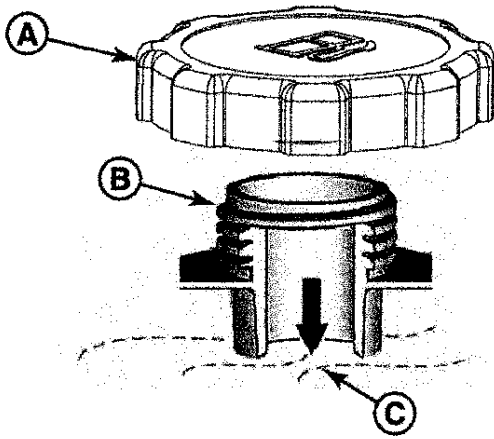

Start the Engine



Fuel and its vapors are extremely flammable and explosive. Always handle fuel with extreme care. Failure to obey these safety instructions can cause a fire or explosion which could result in severe burns or death.

- Make sure that spark plug, muffler, fuel cap, and air cleaner (if equipped) are installed correctly.
- Do not crank the engine without the spark plug.
- Do not use pressurized starting fluids because their vapors are flammable.
- Do not over-prime the engine. Read *Start the Engine* instructions in this manual.
- If the engine floods, set the choke to the OPEN/RUN position, move the throttle to FAST position, and crank the engine until it starts.

1. Make sure the auger control (J, Figure 6) and traction control (K) are disengaged.
2. Turn the fuel shut-off valve (A) (if equipped) to the OPEN position.
3. Move the throttle control lever (B) (if equipped) to the FAST position.
4. Turn the ignition key (C) to the ON position or push in the Push/Pull key.
5. Turn the choke control (D) to the CLOSED position.

Note: The choke and primer are usually not needed to start a warm engine.

6. Push the primer button (E) two times.

7. On rewind start models, hold the starter cord handle (F) tightly. Pull the handle slowly until resistance is felt, then pull rapidly.



Rapid retraction of the starter cord (kickback) will pull your hand and arm toward the engine faster than you can let go. Broken bones, fractures, bruises, or sprains could result.

6

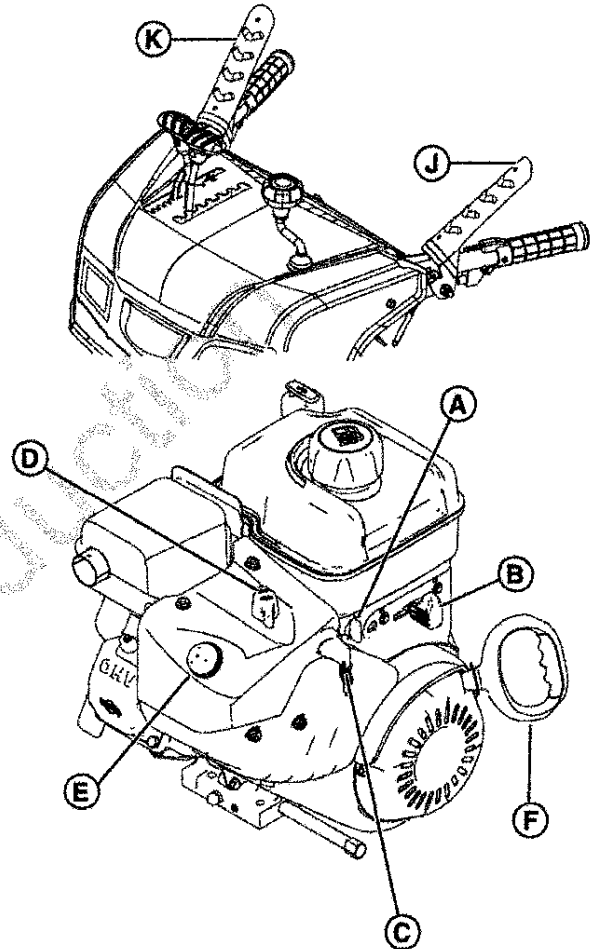

8. On electric start models, connect an extension cord, if included, to the starter box (H, Figure 7), and then to the wall receptacle. Push the starter box button (I). After the engine starts, disconnect the extension cord from the wall receptacle and then from the starter box.



Damaged or non-grounded power cords could cause electric shock. Electric shock could cause severe burns or death.

- Use only a three-conductor power cord that is correctly grounded to the power source.

- If the extension cord is damaged, it must be replaced.

Note: To extend the life of the starter, use short, start cycles at a maximum of five seconds. Wait one minute between start attempts.

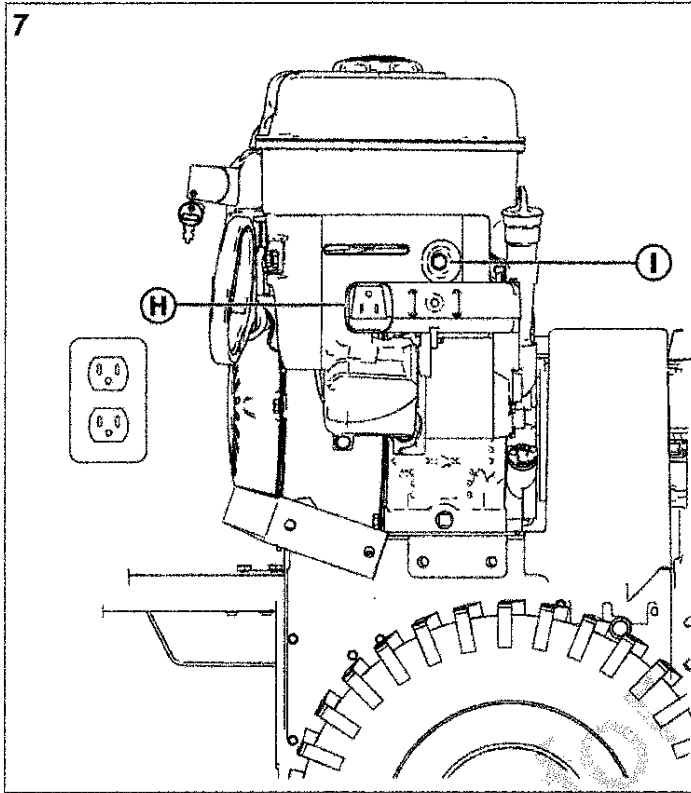

9. Let the engine warm for several minutes. Gradually move the choke control (D) to the OPEN position.

Stop the Engine

1. Turn the ignition key (A, Figure 8) to the OFF position. Remove the ignition key or the Push/Pull key, if equipped.
2. Keep the key in a safe location out of the reach of children. The engine cannot start without the key.

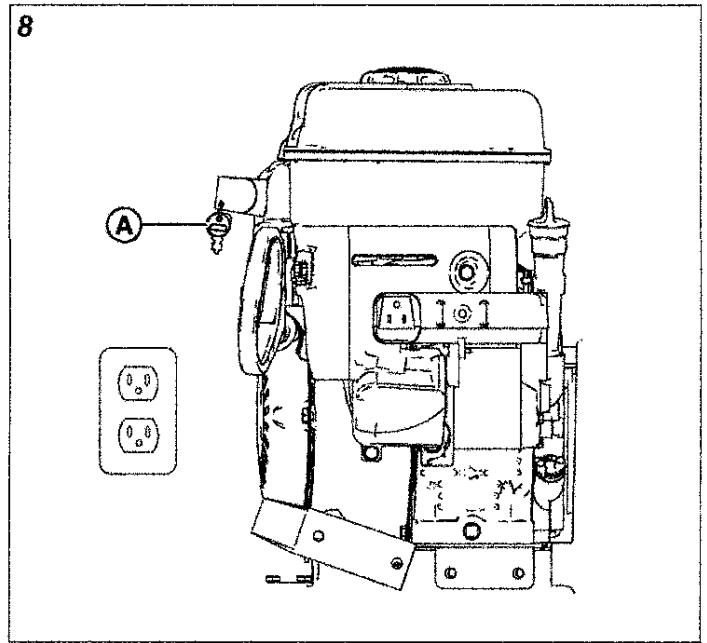

Adjust the Discharge Chute and Deflector



WARNING

Ice, gravel, or other unintended objects can be picked up by the auger and thrown from the chute with force. Objects thrown from the chute could cause death, serious injury, or property damage.

- Always be aware of the direction the snow is being thrown.
1. Turn the chute rotation crank (D, Figure 9) to set the direction of the discharge chute.
 2. Use the deflector wing knob (C) to move the deflector up or down. Raise the deflector to throw snow farther.
 3. Use the speed control lever (B) to select the forward or reverse drive speed. Use lower speeds to remove wet, heavy snow. Use higher speeds for light snow.

Note: Make sure to release the traction control lever (F) before you change speeds.

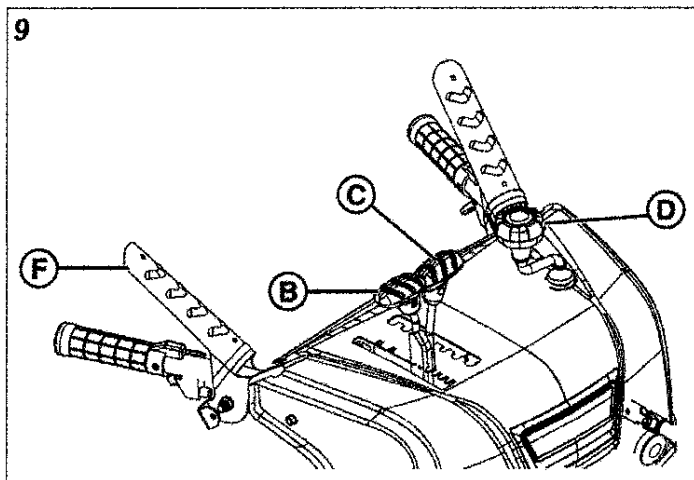

2. Select a lower number for heavy snow, a middle number for light snow, and a higher number to transport the snowthrower.
3. Push and hold down the traction control lever (F).
4. To move the snowthrower in reverse, set the speed control lever to R1 or R2.
5. Push and hold down the traction control lever.
6. To stop the snowthrower, release the traction control lever. The unit will stop immediately.
 - If the unit does not stop, adjust the control cable. See *Adjust the Traction Control Cable*.
 - If the unit still does not stop, see an Authorized Service Dealer.

Note: If you remove snow at too fast of a rate, it will overload the machine capacity.

Engage the Auger and Impeller



The snowthrower contains a rotating auger and impeller that throws snow. Fingers or feet can quickly become caught in the rotating auger or impeller, which can result in traumatic amputation or severe laceration.

1. Push and hold down the auger control lever (A, Figure 10) to engage the auger and impeller.
2. Release the auger control lever to disengage the auger and impeller.
 - If the auger and impeller does not stop in five seconds adjust the control cable. See *Adjust the Auger and Impeller Control Cables*.
 - If the auger and impeller still does NOT stop in five seconds, see an Authorized Service Dealer.

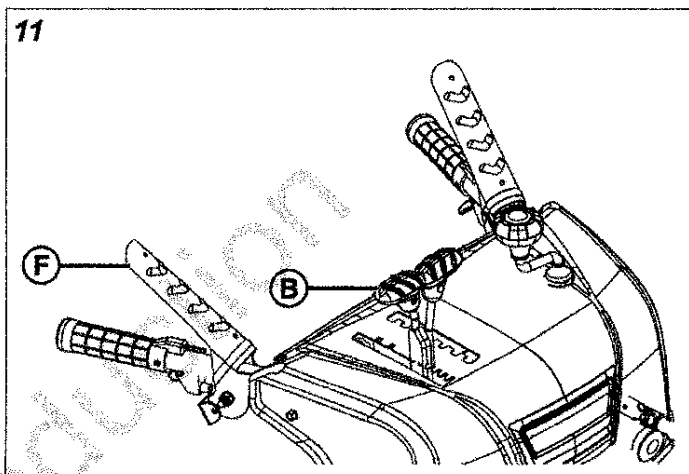
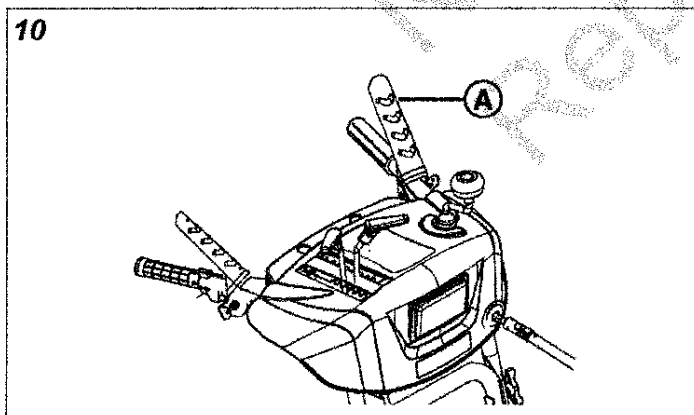

Use the Free Hand™ Feature

After the traction control and auger control is engaged, the operator can release the auger control lever to use other controls. If your model is equipped with this feature, it will have a decal (Figure 12) on the dash panel.

Engage the Drive Wheels

NOTICE DO NOT move the speed control lever while the traction control lever is engaged. This can result in damage to the drive system.

1. To move the snowthrower forward, set the speed control lever (B, Figure 11) to one of the forward positions.

12

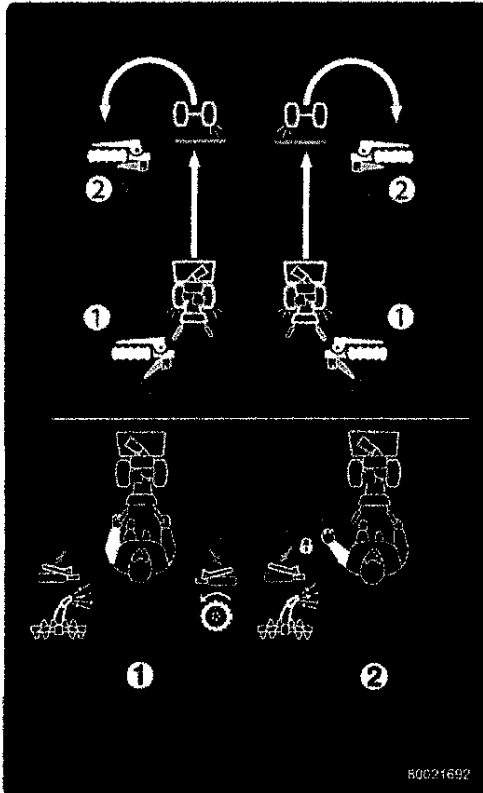

1. Push down and hold the auger control lever (A, Figure 13).
2. Push down and hold the traction control lever (F).
3. Release the auger control lever so that the left hand can reach other controls. If the auger stops, see an Authorized Service Dealer.

13

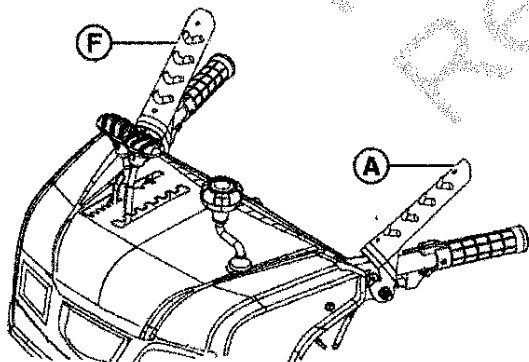

Clean a Clogged Discharge Chute



The rotating impeller in the discharge chute throws snow. Fingers can quickly become caught in the impeller and result in traumatic amputation or severe laceration. **DO NOT** use your hands to clean a clogged discharge chute! Always use a clean-out tool.

1. STOP the engine. Remove the ignition key or push/pull key.
2. Make sure that the impeller does not rotate.
3. Use a clean-out tool (G, Figure 14) to remove snow from the discharge chute. **DO NOT** use your hands to clean a clogged discharge chute!

14

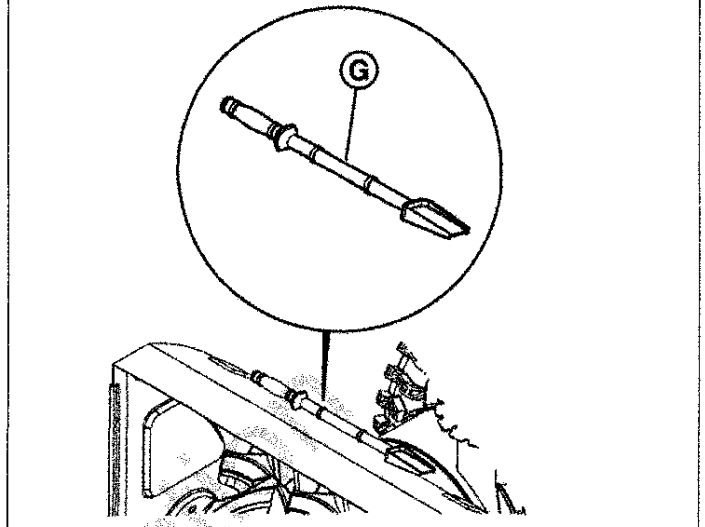

Headlight

Some models are equipped with a headlight that illuminates the area in front of the snowthrower. When you START the engine, the headlight turns ON. There is no switch.

Use the Wheel Release - Lock Pins (if equipped)

When you move the unit to a different location, you can temporarily disengage one or two wheels from the drive axles.

1. Open the pull-ring (A, Figure 15) over the wheel hub.

15

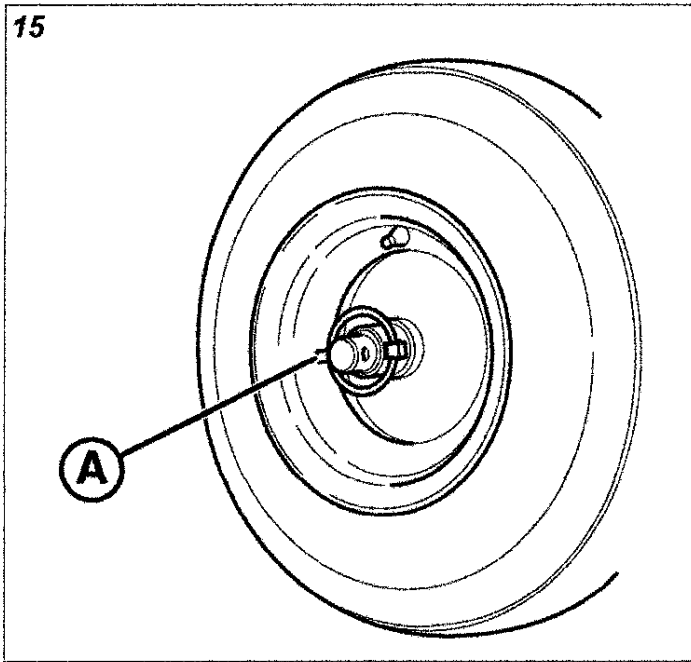

2. Put the retaining pin through the outer hole in the axle and close the pull-ring over the axle.
3. Align the wheel hub and the inner axle hole, then install the retaining pin fully and close the pull-ring over the wheel hub. This engages the wheel and axle.

Maintenance and Adjustments

We recommend you contact an Authorized Service Dealer for all maintenance, adjustments, and servicing of the unit. The owner can do some routine maintenance tasks. Refer to the maintenance schedule and procedures that follow.

CAUTION

All the components used to build this product must remain installed for correct operation. Replacement parts must be of the same design and installed in the same position as the original parts. Other parts may not do as well, damage the unit, and result in injury.

WARNING

This snowthrower must be correctly maintained to ensure safe operation and performance. Failure to obey the safety instructions in this manual could result in death or serious injury.

- Before you do maintenance or repairs on the snowthrower, STOP the engine. Remove the ignition key or pull out the PUSH/PULL key.

Maintenance Schedule

First 5 Hours
Change the oil.
Before Each Use

- Check the engine oil level.

- Check the auger stop time.

After Each Use

Remove accumulated snow and slush to prevent freezing of the controls, wheels, discharge chute, and auger.

Every 25 Hours or Annually

- Check the scraper bar for wear.
- Change the engine oil.
- Check the snowthrower for loose hardware.
- Check the auger control cable adjustment.
- Check the muffler and muffler guard.
- Replace the spark plug (dealer service).
- Check the valve clearance* (dealer service).

* Not required unless problems are noted with engine performance.

Emissions Control

Maintenance, replacement, or repair of the emissions control devices and systems can be serviced by a non-road engine repair establishment or individual. However, to obtain "no charge" emissions control service, the work must be serviced by a factory authorized dealer.

Change the Engine Oil

Discard used oil correctly. Do not discard with household waste. Check with your local authorities, service center, or dealer for safe disposal or recycling facilities.

Use Briggs & Stratton® Synthetic 5W-30 Warranty Certified oil for best performance. Other high-quality detergent oils are acceptable if classified for service SG, SH, SJ or higher. Do not use any additives.

1. STOP the engine. Turn the ignition key to the OFF position.
2. Remove the ignition key, or pull out the Push/Pull key (if equipped).

WARNING

Fuel and its vapors are extremely flammable, which could cause burns or fire that result in death or serious injury.

- When performing maintenance that requires the unit to be tipped, the fuel tank must be empty or fuel can leak out and result in a fire or explosion.
3. Remove the oil drain plug (D, Figure 16). Tilt the snowthrower a small distance rearward. Drain the oil into an approved container.
 4. Install and tighten the oil drain plug.

16

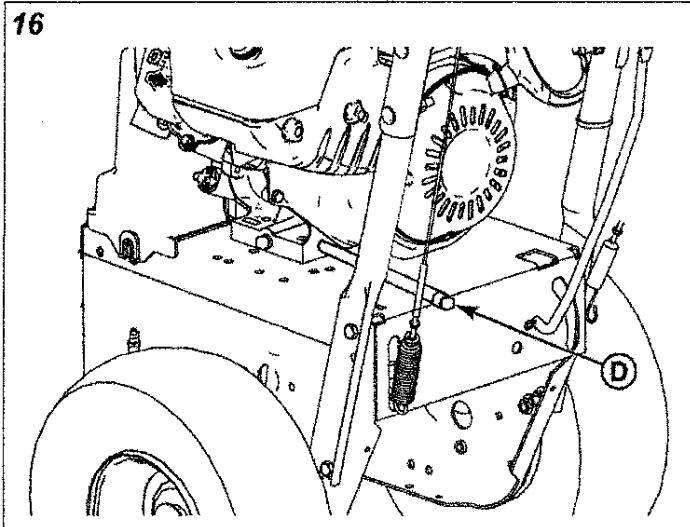

5. Put the unit on a level surface.
6. Clean the oil fill area.
7. Remove the dipstick (A, Figure 17).

17

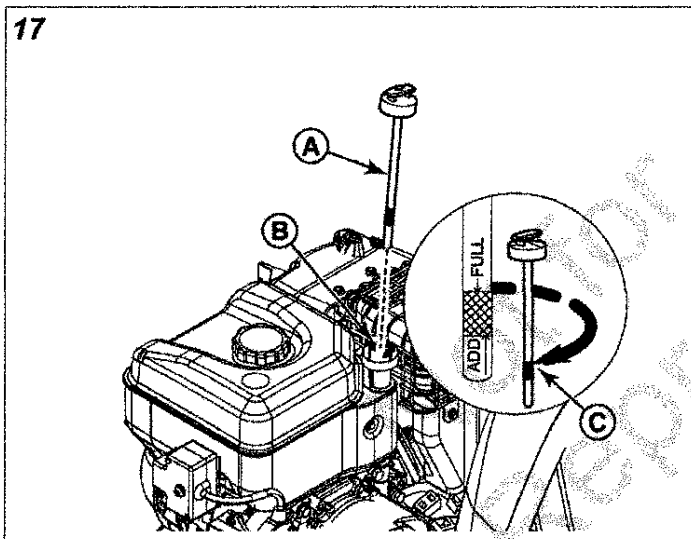

8. Slowly add oil into the oil fill tube (B). See Specifications for the oil capacity.
9. Wait one minute. Check the oil level again.
10. When the oil level touches the top of the full indicator (C), install and tighten the dipstick.

Adjust the Skid Shoe Height



This snowthrower contains a rotating auger that collects snow. Fingers can quickly become caught and can result in a traumatic amputation or a severe laceration.

- STOP the engine. Wait for all moving parts to stop. Remove the ignition key or push/pull key before maintenance or repairs.



If hit by the auger or impeller, objects such as gravel, rocks, or other unwanted material can be thrown with sufficient force and cause personal injury, property damage, or damage to the snowthrower.

The skid shoes are on each side of the auger housing. They can be adjusted to increase or decrease the distance between the scraper bar and the surface to be cleared.

Set the skid shoes at the correct height to maintain ground clearance for the type of surface being cleared.

1. STOP the engine. Remove the ignition key or push/pull key.
2. Find the scraper bar clearance needed for the surface to be cleared.
 - To remove snow from hard surface areas, adjust the skid shoes up to lower the scraper bar closer to the surface.
 - To remove snow from gravel-covered or uneven surfaces, adjust the skid shoes down to raise the scraper bar further from the surface. This will help prevent rocks and other unwanted materials from being picked up and thrown by the auger and impeller.
3. Put the unit on a level surface.
4. Loosen the mounting nuts (E, Figure 18) on the skid shoe (H).

18

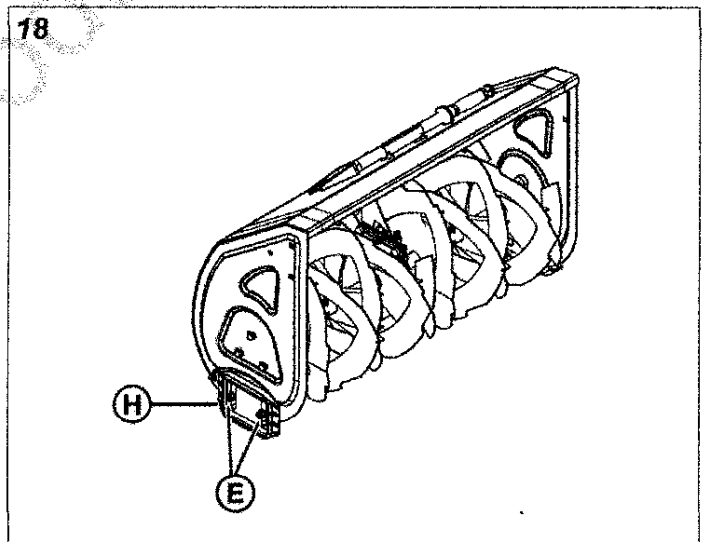

5. Under each end of the scraper bar, put a wooden block (y, z, Figure 19) of the same thickness at the desired clearance height.

19

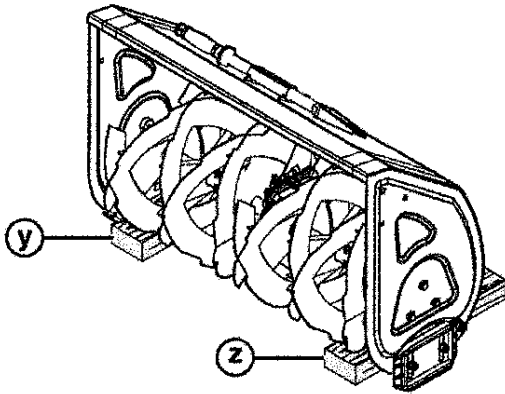

6. Make sure that each skid shoe firmly touches the surface. Then tighten the mounting nuts.

NOTICE To prevent contact with the auger, make sure that the mounting nuts are outside the auger housing.

Lubricate the Control Lever Linkage

Apply grease to the control lever linkage at the locations (A) as shown in Figure 20.

20

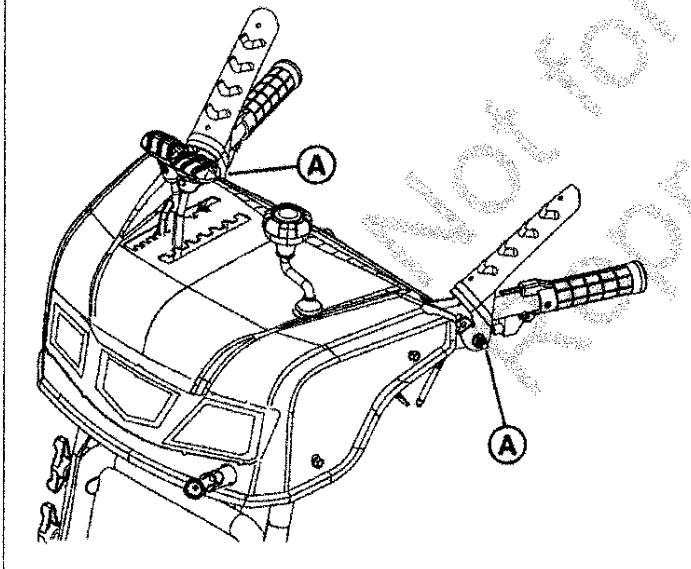

Lubricate the Discharge Chute, Deflector, and Wheel Axle

1. STOP the engine and remove the key.
2. Lubricate the discharge chute (A, Figure 21) with lithium grease.
3. Lubricate the deflector (B) with clean engine oil.
4. Lubricate the wheel axles (C) with lithium grease.

21

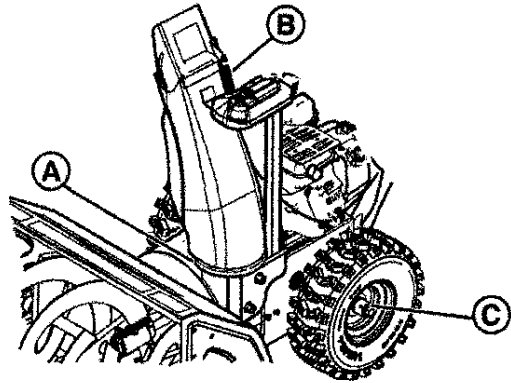

Lubricate the Auger Assembly

1. STOP the engine and remove the key.
2. Lubricate the auger shaft assembly (A, Figure 22) with grease at the grease fittings, (if equipped).

22

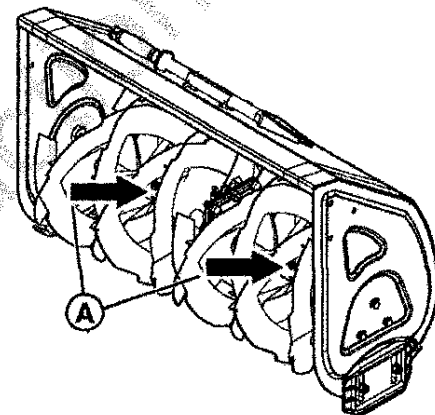

Lubricate the Hex Shaft and Gear

For friction drive systems only:

NOTICE Do not let grease or oil touch the rubber friction wheel or the disc drive plate. If grease or oil touches the friction wheel, replace it. Do not clean it. If grease or oil touches the disc drive plate, clean it thoroughly with an alcohol based solvent.

1. STOP the engine. Remove the ignition key or push/pull key.
2. Set the speed select lever to the first forward gear.



Fuel and its vapors are extremely flammable, which could cause burns or fire that result in death or serious injury.

- When performing maintenance that requires the unit to be tipped, the fuel tank must be empty or fuel can leak out and result in a fire or explosion.

3. Lift the snowthrower up on the auger housing end.
Note: When you fill the crankcase with oil, do not let the snowthrower stand on the auger housing for an extended period of time.

4. Remove the screws (A, Figure 23) and bottom panel (B).

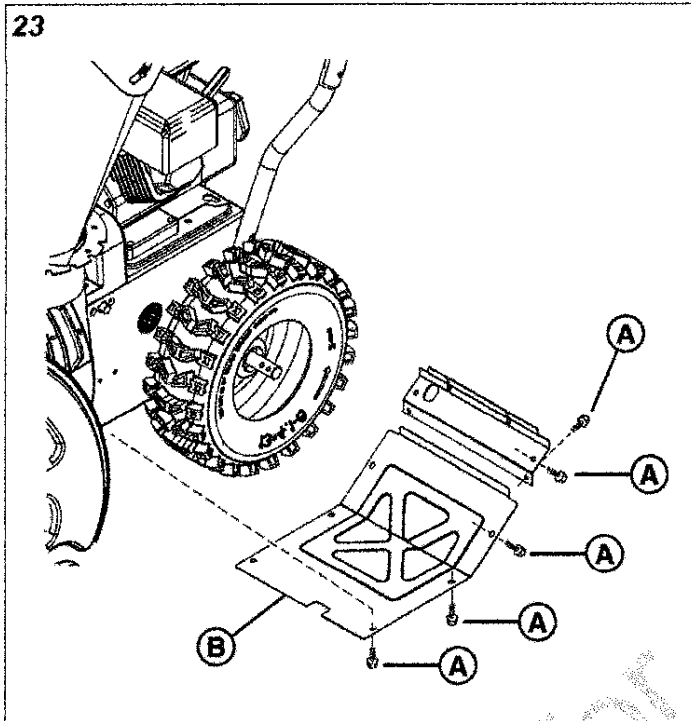

5. Apply a very thin layer of 50 weight synthetic motor oil to the hex shaft (C, Figure 24). Do this before storage and at the start of each season.

NOTICE Do not let grease or oil touch the rubber friction wheel or the disc drive plate. If grease or oil touches the friction wheel, replace it. Do not attempt to clean it. If grease or oil touches the disc drive plate, clean it fully with an alcohol based solvent.

6. Lightly, lubricate the sprocket (D) and chain (E) with motor oil, before storage and at the start of each season.

24

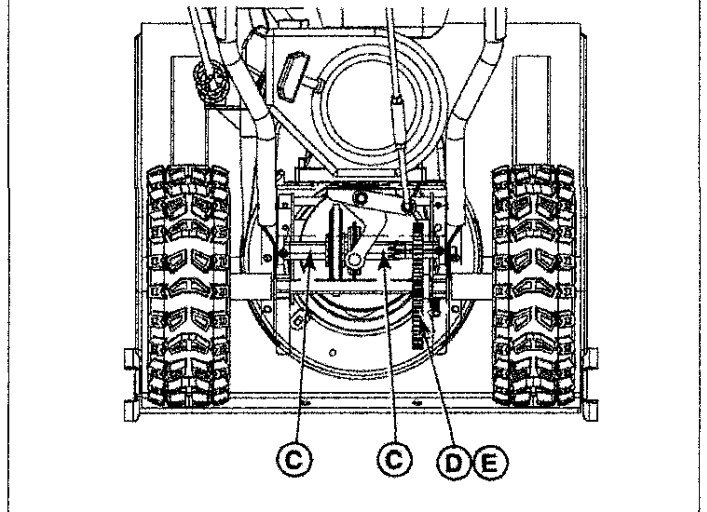

Adjust the Traction Control and Auger Cables

The traction cables and drive belt are adjusted at the factory. Adjustments are not necessary. However, if the cables are stretched, an adjustment might be necessary. Please see an Authorized Service Dealer for these adjustments.

Replace the Auger Shear Pins



The snowthrower contains a rotating auger and impeller that throws snow. Fingers or feet can quickly become caught in the auger or impeller and result in traumatic amputation or severe laceration.

- STOP the engine, wait for all moving parts to stop, and remove the engine key before maintenance or repairs.
1. STOP the engine. Remove the key.
 2. Remove the shear pins and clips.
 3. Apply grease to the auger grease fittings, (if equipped). Turn the auger quickly to lubricate the auger shaft.
 4. Align the bolt holes. Install the new shear pins (A, Figure 25) through the auger shaft (B). Install the clips (C) into the holes of the shear pins.

25

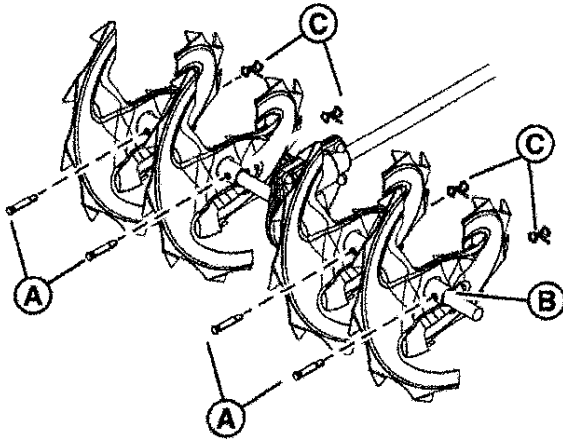

Tire pressure should be checked regularly. Recommended tire pressure changes by tire manufacturer. A good rule of thumb is to inflate the tire up to, but not more than, the "Max inflation" stamped on the side-wall of the tire.

Storage

Storage - Fuel System

Fuel can become stale when kept in a storage container for more than 30 days. Each time you fill the container with fuel, add STA-BIL 360[®] PROTECTION™ to the fuel as specified by the manufacturer's instructions. This keeps fuel fresh and decreases fuel-related problems or contamination in the fuel system.

It is not necessary to drain fuel from the engine when STA-BIL 360[®] PROTECTION™ is added as instructed. Before storage, turn the engine ON for 2 minutes to move the fuel and stabilizer through the fuel system.

Replace the Impeller Shear Bolts



The snowthrower contains a rotating auger and impeller that throws snow. Fingers or feet can quickly become caught in the auger or impeller resulting in traumatic amputation or severe laceration.

- STOP the engine, wait for all moving parts to stop, and remove the engine key before maintenance or repairs.
1. STOP the engine. Remove the engine key.
 2. Remove the shear bolts (A, Figure 26) and locknuts (C) from the impeller shaft (B).
 3. Align the bolt holes. Install the new shear bolts through the auger shaft. Tighten with the locknuts.

26

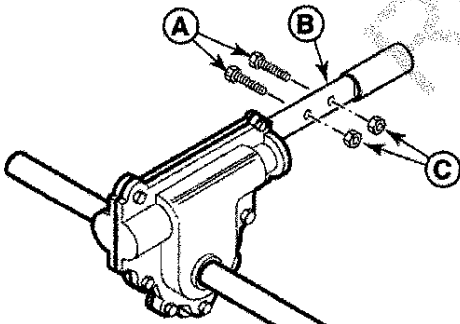

Check the Tire Pressure



Explosion hazard

Over-inflation of tires can cause them to explode, which could result in serious injury.

Do not inflate the tires above the maximum pressure.

Off-Season Storage

At the end of the season, or when the unit is in storage for more than 30 days, complete the steps that follow.



Gasoline is highly flammable and its vapors are explosive. Fumes can move to a distant ignition source and an explosion and/or fire can result.

- If fuel is in the tank, do not keep the unit indoors or in poorly ventilated areas where fumes could reach sparks, open flames, pilot lights, heat, and other ignition sources.

Snowthrower

- Clean the unit. Make sure that all nuts, bolts, and screws are tightened.
- Examine visible moving parts for damage, breakage, and wear. Replace if necessary.

- Lubricate the control lever linkages, chute and deflector, auger assembly, and drive wheel axles. See *Maintenance and Adjustments*.
- For rusted or chipped paint surfaces, sand lightly and apply touch-up paint.
- For unpainted or bare metal surfaces, apply a rust preventative product.
- Keep the unit indoors and cover it. If kept outdoors, cover it with a heavy tarpaulin.

Return the unit to Service

- Contact an Authorized Service Dealer for annual maintenance tasks. See *Maintenance Schedule*.
- Inspect engine oil level and add oil, if necessary.
- Fill the fuel tank with clean fuel.
- Check tire pressures.
- Make sure that all guards, shields, and covers are attached.
- Make sure that all fasteners are tightened.
- Inspect the auger and impeller control, and the traction drive control.

Troubleshooting

Problem	Cause	Solution
The auger does not stop when the auger control is released.	Adjust the auger control cable.	See <i>Adjust the Auger Control Cable</i> .
The auger does not turn when the auger control is engaged.	Adjust the auger control cable.	See <i>Adjust the Auger Control Cable</i> .
The engine does not start.	The ignition key is set to the OFF position or the PUSH/PULL key is not in the key slot.	Turn the ignition key to the ON position or put the PUSH/PULL key into the key slot.
	The primer button was not pushed 2-times before you pulled the starter rope.	Push the primer button 2-times before you pull the starter rope.
	The fuel tank is empty.	Fill the fuel tank with fresh fuel.
	The choke is open.	Turn the choke to the CLOSED position before you pull the starter rope.
	The engine is flooded.	Turn the choke to open position. Pull the starter rope until the engine starts.
	Water is in the fuel or if the fuel is used.	Fill the fuel tank with fresh fuel.
The chute rotation or deflector adjustment does not work.	The chute or deflector is frozen.	Keep the snowthrower in a warm area until the snow or ice melts.
The engine is hard to start or operation performance is unsatisfactory.	Incorrect oil.	Change oil to lighter viscosity. See <i>Oil Recommendations</i> .
	The choke control is set incorrectly.	As the engine warms, gradually open the choke control.
There is too much vibration.	Parts are loose or damaged.	Stop the snowthrower immediately. Contact an Authorized Service Dealer.
The snowthrower does not throw snow.	Adjust the auger control cable.	See <i>Adjust the Auger Control Cable</i> .
	Snow is in the discharge chute.	STOP THE ENGINE! Make sure that the auger STOPS. Use a clean-out tool to remove snow from the discharge chute. Do not clean a clogged discharge chute with your hands! See <i>Clean a Clogged Discharge Chute</i> .

For all other issues, please see an Authorized Service Dealer.

Specifications

Specification Chart

The spark ignition system on this snowthrower complies with Canadian standard ICES-002.

Item	Model 130000
Armature Air Gap	.010 - .014 inch (.25 - .36 mm)
Intake Valve Clearance	.004 - .006 inch (.10 - .15 mm)
Exhaust Valve Clearance	.006 - .008 inch (.15 - .20 mm)
Oil Capacity	18 - 20 oz (.54 - .59 L)
Spark Plug Gap	.030 inch (.76 mm)

Engine power will decrease 3.5% for every 1,000 feet (300 meters) above sea level and 1% for every 10 degrees F (5.6 degrees C) above 77 Degrees F (25 Degrees C). The engine will operate satisfactorily at an angle up to 15 degrees.

Power Ratings

The gross power rating for individual gasoline engine models is labeled in accordance with SAE (Society of Automotive Engineers) code J1940 Small Engine Power & Torque Rating Procedure, and is rated in accordance with SAE J1995. Torque values are derived at 2600 RPM for those engines with "rpm" called out on the label and 3060 RPM for all others; horsepower values are derived at 3600 RPM. The gross power curves can be viewed at www.BRIGGSandSTRATTON.COM. Net power values are taken with exhaust and air cleaner installed whereas gross power values are collected without these attachments. Actual gross engine power will be higher than net engine power and is affected by, among other things, ambient operating conditions and engine-to-engine variability. Given the wide array of products on which engines are placed, the gasoline engine may not develop the rated gross power when used in a given piece of power equipment. This difference is due to a variety of factors including, but not limited to, the variety of engine components (air cleaner, exhaust, charging, cooling, carburetor, fuel pump, etc.), application limitations, ambient operating conditions (temperature, humidity, altitude), and engine-to-engine variability. Due to manufacturing and capacity limitations, Briggs & Stratton may substitute an engine of higher rated power for this engine.

Not for
Reproduction