

AMANA®

Use and Care Guide Guide d'utilisation et d'entretien

Front-Loading Automatic Washer Laveuse automatique à chargement frontal

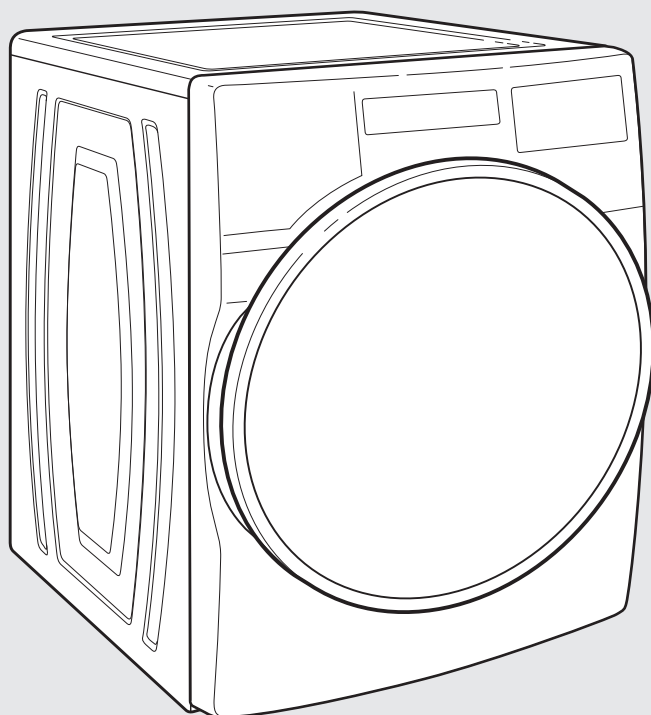

Para obtener acceso al Manual de uso y cuidado en español, o para obtener información adicional acerca de su producto, visite: www.amana.com

If you have any problems or questions, visit us at www.amana.com
Pour tout problème ou toute question, consulter www.amanacanada.ca

W11156981B
W11156982B – SP



Designed to use only HE High Efficiency detergents.

Conçue pour l'utilisation d'un détergent haute efficacité seulement.

TABLE OF CONTENTS

WASHER SAFETY	3
ACCESSORIES.....	4
CONTROL PANEL AND FEATURES	5
CYCLE GUIDE.....	7
CHOOSING THE RIGHT DETERGENT	9
USING THE DISPENSERS.....	9
USING YOUR WASHER.....	10
WASHER MAINTENANCE	14
TROUBLESHOOTING	17
WARRANTY	26
ASSISTANCE OR SERVICE.....	Back Cover

TABLE DES MATIÈRES

SÉCURITÉ DE LA LAVEUSE	27
ACCESSOIRES.....	28
TABLEAU DE COMMANDE ET CARACTÉRISTIQUES	29
GUIDE DES PROGRAMMES.....	32
CHOIX D'UN DÉTERGENT APPROPRIÉ.....	35
UTILISATION DES DISTRIBUTEURS.....	35
UTILISATION DE LA LAVEUSE	36
ENTRETIEN DE LA LAVEUSE	40
DÉPANNAGE	43
GARANTIE.....	55
ASSISTANCE OU SERVICE.....	Couverture arrière

WASHER SAFETY

Your safety and the safety of others are very important.

We have provided many important safety messages in this manual and on your appliance. Always read and obey all safety messages.



This is the safety alert symbol.

This symbol alerts you to potential hazards that can kill or hurt you and others.

All safety messages will follow the safety alert symbol and either the word "DANGER" or "WARNING." These words mean:

! DANGER

You can be killed or seriously injured if you don't immediately follow instructions.

! WARNING

You can be killed or seriously injured if you don't follow instructions.

All safety messages will tell you what the potential hazard is, tell you how to reduce the chance of injury, and tell you what can happen if the instructions are not followed.

IMPORTANT SAFETY INSTRUCTIONS

WARNING: To reduce the risk of fire, electric shock, or injury to persons when using the washer, follow basic precautions, including the following:

- Read all instructions before using the washer.
- Do not wash articles that have been previously cleaned in, washed in, soaked in, or spotted with gasoline, dry-cleaning solvents, other flammable, or explosive substances as they give off vapors that could ignite or explode.
- Do not add gasoline, dry-cleaning solvents, or other flammable, or explosive substances to the wash water. These substances give off vapors that could ignite or explode.
- Under certain conditions, hydrogen gas may be produced in a hot water system that has not been used for 2 weeks or more. **HYDROGEN GAS IS EXPLOSIVE.** If the hot water system has not been used for such a period, before using the washing machine, turn on all hot water faucets and let the water flow from each for several minutes. This will release any accumulated hydrogen gas. As the gas is flammable, do not smoke or use an open flame during this time.
- Do not allow children to play on or in the washer. Close supervision of children is necessary when the washer is used near children.
- Before the washer is removed from service or discarded, remove the door or lid.
- Do not reach into the washer if the drum, tub or agitator is moving.
- Do not install or store the washer where it will be exposed to the weather.
- Do not tamper with controls.
- Do not repair or replace any part of the washer or attempt any servicing unless specifically recommended in this manual or in published user-repair instructions that you understand and have the skills to carry out.
- See Installation Instructions for grounding instructions.

SAVE THESE INSTRUCTIONS

ACCESSORIES

INSTALLATION & MAINTENANCE ACCESSORIES

FACTORY CERTIFIED PARTS – these three words represent quality parts and accessories designed specifically for your appliance. Time tested engineering that meets our strict quality specifications.

FACTORY CERTIFIED PARTS

Accessories designed for your appliance:

Customize your new washer and dryer with the following genuine Amana accessories. For more information on options and ordering, call **1-800-843-0304** or visit us at: **www.amanaparts.com**. In Canada, call **1-800-807-6777** or visit us at **www.amanacanada.ca**.

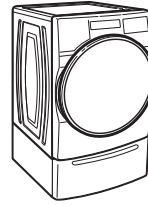

15" Pedestal

Color-matched pedestals raise the washer and dryer to a more comfortable working height. The large drawer provides convenient storage.

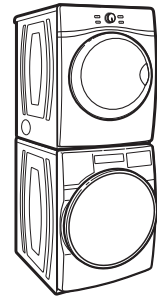

Stack Kit

If space is at a premium, the stack kit allows the dryer to be installed on top of the washer.

CONTROL PANEL AND FEATURES

NOTES:

- Not all features and cycles are on all models.
- If your model has a touch interface, the control panel features a sensitive surface that responds to a light touch of your finger. To ensure your selections are registered, touch the control panel with your fingertip, not your fingernail. When selecting a setting or option, simply touch its name.
- If your model has physical buttons, make sure to press the button firmly.
- At cycle completion, your setting and option choices will be remembered for the next cycle. However, if power to the washer is lost, the settings and options will go back to the factory defaults.

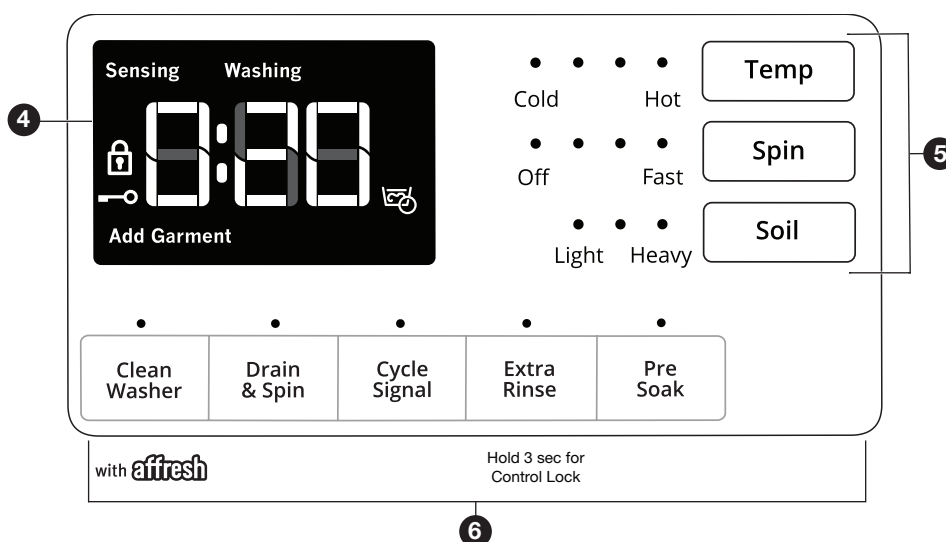
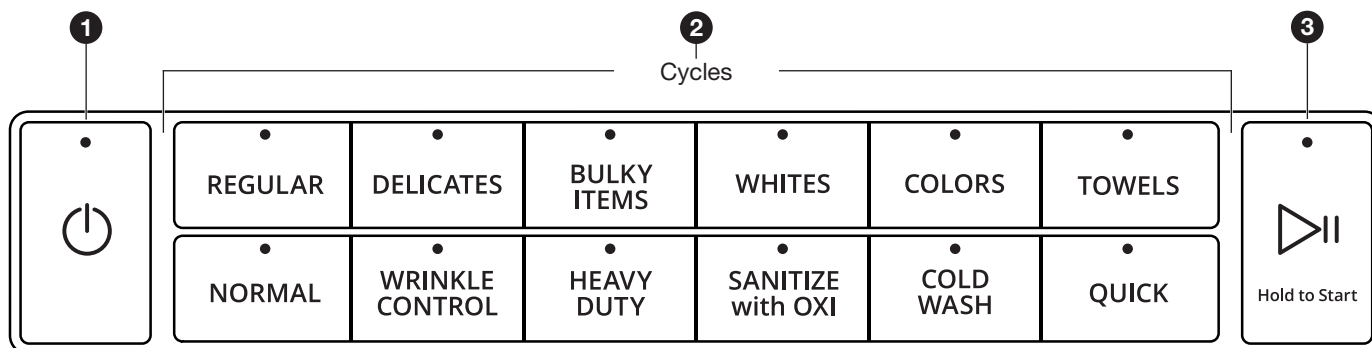

Cycles and settings vary by model.

1 POWER

Select to turn the washer on and off. Select to stop/cancel a cycle at any time.

2 CYCLES

At each stage of the process, you may notice sounds or pauses that are different from traditional washers.

Press to select a cycle for your load.

3 START/PAUSE

Touch and hold for 3 seconds until the light above START/PAUSE comes on to start a cycle, or touch once while a cycle is in process to pause it.

4 CYCLE STATUS DISPLAY

The CYCLE STATUS DISPLAY shows the progress of a cycle. At each stage of the process, you may notice sounds or pauses that are different from traditional washers.

Estimated Time Remaining

The Estimated Time Remaining shows the time required for the cycle to complete. Factors such as load size,

modifiers, options selected, and water pressure may affect the time shown in the display. Tightly packed loads, unbalanced loads, or excessive suds may cause the washer to lengthen the cycle time as well.

Sensing

When START/PAUSE is touched the washer will chime, indicating it is starting, and "Sensing" will display. The drum will make a partial turn. The door will click one more time when it locks.

Once the door has locked, the washer will start.

This sensing process will continue throughout the cycle. After the load is sensed, the estimated time based on load size will be displayed and water will be added. You may hear water flowing through the dispenser, adding detergent to the load.

The actual cycle time may be lengthened; however, the display will continue to show the estimated time.

In the display, "Sensing" may blink once a second at various times during the cycle, such as when the washer is reducing extra suds.

Washing

During the wash cycle, this will display to let you know the cycle is in progress.

Presoak

This symbol will be displayed to let you know a presoak is in progress.



Add Garment

When "Add Garment" is displayed, you may pause the washer, open the door, and add items. Touch and hold START/PAUSE to start the washer again.

Door Locked

The Door Locked symbol will display to indicate that the door is locked and cannot be opened without first pausing or canceling the cycle.



Control Lock

When the Control Lock symbol is displayed, the buttons are disabled. Touch and hold EXTRA RINSE for 3 seconds to enable the buttons.



End

Once the cycle is complete, "End" will display. Remove the load promptly for best results.

5 CYCLE MODIFIERS

When you select a cycle, its default settings will light up. Touch to adjust cycle modifiers on the washer before touching START/PAUSE. Additional wash modifiers or options selected after touching START/PAUSE may not activate.

Once a wash setting is selected, it is saved for the cycle selected. To return to factory default cycle settings, unplug washer for 30 seconds; then plug back in. See the "Cycle Guide" for default cycle settings.

NOTE: Some modifiers may increase or decrease the estimated time remaining.

Temp

The recommended wash temperature is preset for each cycle. Some preset temperatures can be changed. You may select a different wash temperature based on the level of soil and type of fabric being washed. For best results, use the warmest wash water safe for your fabric, following the garment label instructions. All wash temperatures feature a cold rinse.

Spin

The recommended spin speed is preset for each cycle. Some preset speeds can be changed.

- Faster spin speeds mean shorter dry times, but may increase wrinkling in your load.
- Slower spin speeds reduce wrinkling, but will leave your load more damp.

Soil

The recommended soil level is preset for each cycle. Some preset soil levels can be changed. For heavily soiled and sturdy fabrics, select the Heavy Soil Level setting. For lightly soiled and delicate fabrics, select the Light Soil Level setting. Lower soil level settings will help reduce tangling and wrinkling.

6 OPTIONS

You may add or remove options for each cycle. Not all options can be used with all cycles, and some are preset to work with certain cycles. Options vary by model.

UTILITY TOOLS

Clean Washer

Use this every 30 washes to keep the inside of your washer fresh and clean. This cycle uses a higher water level. Use with affresh® Washer Cleaner tablets or liquid chlorine bleach to thoroughly clean the inside of your washer. When using this cycle, the drum should be empty. This cycle should not be interrupted. See the "Washer Care" section.

Drain & Spin

This cycle removes excess water from the load or special-care items washed by hand. Use this cycle after a power failure. For some fabrics, you may choose to set a slower spin speed.

CYCLE OPTIONS

Extra Rinse

Activate this option to add an extra rinse to most cycles.

You can also touch and hold EXTRA RINSE for 3 seconds to disable/enable the Control Lock.

Presoak (on some models)

Touch to add a Presoak time of your choice to a wash cycle.



7 DISPENSERS

Single Load Dispenser Drawer

The single load dispenser drawer gives you the convenience of adding HE detergent, liquid chlorine bleach, and liquid fabric softener to the wash load at the proper time. See the "Using the Dispensers" section for information on using the dispenser drawer.

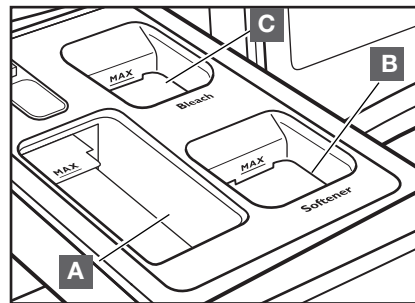

A High Efficiency (HE) detergent compartment

This compartment holds liquid or powdered HE detergent for your main wash cycle, and automatically dispenses detergent in the cycle.

B Liquid fabric softener compartment

This compartment holds liquid fabric softener. It automatically dispenses liquid fabric softener at the optimum time in the cycle.

C Liquid chlorine bleach compartment





This compartment automatically dilutes and dispenses liquid chlorine bleach at the optimum time during the first rinse after the wash cycle. It cannot dilute powdered bleach.









CYCLE GUIDE

Settings and options shown in **bold** are default settings for that wash cycle. For best fabric care, choose the cycle, options, and settings that best fit the load being washed. Always read and follow fabric care labels and laundry product instructions. Not all settings are available with each cycle, and some options cannot be used together. Not all options are available on all models.





Load Size Recommendations

For best results, follow the load size recommendations noted for each cycle.

- 
Small load: Fill the washer drum with 3–4 items, not more than ¼ full.
- 
Large load: Fill the washer drum up to about ¾ full.
- 
Medium load: Fill the washer drum up to about ½ full.
- 
Extra-large load: Fill the washer drum, but make sure clothes can tumble freely. For best results, avoid packing tightly.

Items to wash using default cycle settings:	Cycle:	Wash Temperature*	Spin Speed	Soil Level:	Options:	Cycle Details:
Normally soiled cottons, linens, sheets, and mixed garment loads	Normal	Cold Cool Warm Hot	Off Medium Fast	Light Normal Heavy	PreSoak Extra Rinse	 This cycle combines medium-speed tumbling and an extra-high-speed spin. This cycle is designed to provide the most energy efficiency.
Small loads of 2–4 lightly soiled garments	Quick	Cold Cool Warm Hot	Off Slow Medium Fast	Light Normal Heavy	PreSoak Extra Rinse	 For small loads (2–4 items) needed quickly. This cycle combines high-speed tumbling, a shortened wash time, and an extra-high speed spin for reduced drying times.
Lightly soiled shirts, blouses, trousers, pants, and dresses	Wrinkle Control	Cold Cool Warm Hot	Off Slow Medium Fast	Light Normal Heavy	PreSoak Extra Rinse	 This cycle combines low-speed tumbling and medium-speed spin for gentle fabric care and reduced wrinkling.
Sturdy colorfast fabrics and heavily soiled garments	Heavy Duty	Cold Cool Warm Hot	Off Slow Medium Fast	Light Normal Heavy	PreSoak Extra Rinse	 Fast-speed tumbling and an extra-fast-speed final spin help provide optimal cleaning and reduce drying times.
Bright or darkly colored cottons, linens, casual, and mixed loads	Cold Wash	Cold	Off Slow Medium Fast	Light Normal Heavy	PreSoak Extra Rinse	 This cycle uses a concentrated detergent solution along with cold water throughout the cycle to gently lift out stains and care for fabrics.
Clothing, bedding and towels requiring sanitization	Sanitize with Oxi	Hot	Off Slow Medium Fast	Light Normal Heavy	Extra Rinse	 This cycle eliminates 99.99% of the most common bacteria found in clothes, sheets, and towels. Using the highest wash temperature available and adding a powdered Oxi product in the drum ensures sanitization. Check recommended wash temperature of your items and use the amount of Oxi recommended by the manufacturer. Bacteria tested were K. pneumonia, P. aureginosa, and S. aureus.]
Moderately soiled cottons, linens, sheets, and mixed garment loads	Regular	Cold Cool Warm Hot	Off Slow Medium Fast	Light Normal Heavy	PreSoak Extra Rinse	 This cycle combines medium-speed tumbling and an extra-high-speed spin.
Bright or darkly colored cottons, linens, casual and mixed loads	Colors	Cold	Off Medium Fast	Light Normal Heavy	PreSoak Extra Rinse	 This cycle combines gentle tumbling and soaking to protect colors and provide a gentle cleaning.

*All temperature selections feature a Cold rinse.

Items to wash using default cycle settings:	Cycle:	Wash Temperature*	Spin Speed	Soil Level:	Options:	Cycle Details:
Moderately soiled white fabrics and garments	Whites	Cold Cool Warm Hot	Off Slow Medium Fast	Light Normal Heavy	PreSoak Extra Rinse	 Uses a longer wash time with fast-speed tumbling, extra rinsing, and an extra fast-speed spin to provide optimal cleaning and rinsing when bleach is used.
Sturdy towels and wash cloths	Towels	Cold Cool Warm Hot	Off Slow Medium Fast	Light Normal Heavy	PreSoak Extra Rinse	 Provides fast-speed tumbling, longer wash time, normal rinsing, and an extra fast-speed spin to shorten drying time.
Sheer fabrics, lingerie, sweaters, and lightly-soiled shirts, blouses, trousers, pants, and skirts	Delicates	Cold Cool Warm Hot	Off Slow Medium Fast	Light Normal Heavy	PreSoak Extra Rinse	 This cycle combines slow-speed tumbling and slow-speed spin for gentle fabric care and reduced wrinkling.
Normally soiled sheets, pillowcases, light blankets, or throws	Bulky Items	Cold Cool Warm Hot	Off Slow Medium Fast	Light Normal Heavy	PreSoak Extra Rinse	 The wash action of this cycle is designed to keep large items from tangling and balling up.

*All temperature selections feature a Cold rinse.

Government energy certifications for models WFW8620H and WFW862CH were based on the REGULAR (WHAT TO WASH), NORMAL (HOW TO WASH), FASTEST SELECTABLE SPIN SPEED, HOLDING "DRAIN & SPIN" for 3 SECONDS TO ACTIVATE TIMED DRY (4 HOURS - 1 TIME ONLY), DRYING TEMPERATURE SETTING NON - SELECTABLE. The as-shipped defaults of REGULAR (WHAT TO WASH), NORMAL (HOW TO WASH), WARM TEMP, SPIN SPEED FAST were not used for energy testing.

CHOOSING THE RIGHT DETERGENT

Use only High Efficiency detergents. The package will be marked "HE" or "High Efficiency." Low-water washing creates excessive sudsing with a non-HE detergent. Using non-HE detergent will likely result in longer cycle times and reduced rinsing performance. It may also result in component malfunction and, over time, buildup of mold or mildew. HE detergents should be low-sudsing and quick-dispersing to produce the right amount of suds for the best performance. They should hold soil in suspension so it is not redeposited onto clean clothes. Not all detergents labeled as High Efficiency are identical in formulation and their ability to reduce suds. For example, natural, organic, or homemade HE detergents may generate a high level of suds. If you use one of these and see a "SUD" error code appear in the display, consider using a different HE detergent. Always follow the detergent manufacturer's instructions to determine the amount of detergent to use.



Use only High Efficiency (HE) detergent.

About Detergent Concentration

Today's liquid HE detergents are concentrated. Most brands of concentrated HE detergent will show the level of concentration on the bottle.

However, if the detergent bottle does not give the concentration, it can be easily calculated. Just divide the package size in fluid ounces by the number of loads. Then refer to the chart below to find the concentration.

If you do not get your desired cleaning results, try using a lower concentration number. If you have excess suds, try using a higher concentration number.

Concentration	Number of ounces ÷ number of loads
2X	1.5–2.49 (44.4 mL–73.6 mL)
3X	0.9–1.49 (26.6 mL–44.1 mL)
4X	0.7–0.89 (20.7 mL–26.3 mL)
5X	0.5–0.69 (14.8 mL–20.4 mL)
6X	0.3–0.49 (8.9 mL–14.5 mL)
8X	< 0.29 (8.6 mL)

USING THE DISPENSERS (varies by model)

1. For a single load, open the single load dispenser drawer at the top left corner of the washer.
2. Add laundry products as described below.
3. Slowly close the dispenser drawer. Make sure it is completely closed.

NOTES:

- A small amount of water may remain in the single load dispenser from the previous wash cycle. This is normal.
- Add single-dose and Oxi-type boosters to the drum before loading items. See the "Using Your Washer" section.

Adding HE detergent to dispenser

Adding detergent for a single load

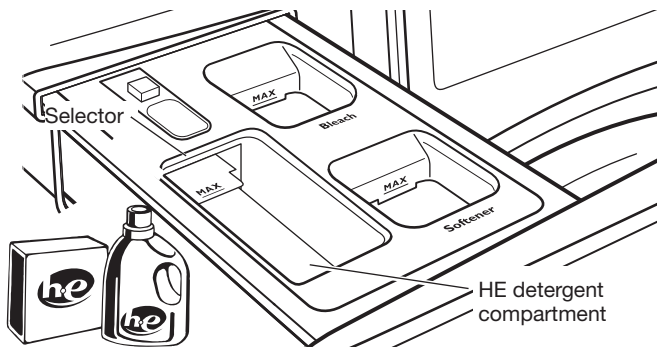

Use only High Efficiency (HE) detergent.

Pour a measured amount of HE detergent into detergent compartment. For powdered detergent, lift the selector to the high position. For liquid detergent, push down the selector to the low position.

Do not overfill; adding too much detergent may cause detergent to be dispensed into the washer too early.

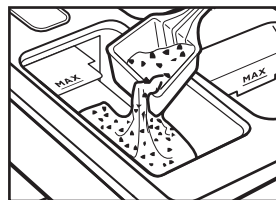

Powdered detergent:
Lift the selector to the high position. Add directly to the compartment.

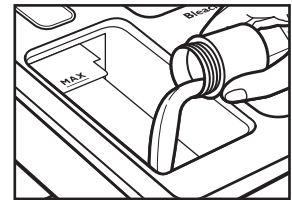

Liquid detergent:
Push down the selector to the low position. Add directly to the compartment.

IMPORTANT:

- Do not add single-dose laundry packet to dispenser drawer.

USING YOUR WASHER

⚠️ WARNING



Fire Hazard

Never place items in the washer that are dampened with gasoline or other flammable fluids.

No washer can completely remove oil.

Do not dry anything that has ever had any type of oil on it (including cooking oils).

Doing so can result in death, explosion, or fire.

First wash cycle without laundry

Before washing clothes for the first time, add detergent to the single-dose dispenser (see the “Using the Dispensers” section). Choose Quick cycle and run it without clothes. Use only HE detergent. This initial cycle serves to ensure the interior is clean.

1. Sort and prepare your laundry

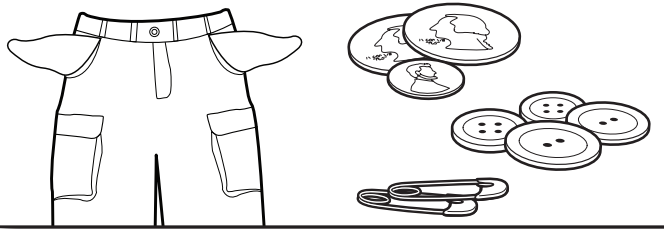

Sort items by recommended cycle, water temperature, and colorfastness. Separate heavily soiled items from lightly soiled. Separate delicate items from sturdy fabrics. Treat stains promptly and check for colorfastness by testing stain remover products on an inside seam.

IMPORTANT:

- Empty pockets. Loose change, buttons, or any small object can plug pumps and may require a service call.
- Close zippers, fasten hooks, tie strings and sashes, and remove non-washable trim and ornaments.
- Mend rips and tears to avoid further damage to items during washing.

⚠️ WARNING



Electrical Shock Hazard

Plug into a grounded 3 prong outlet.

Do not remove ground prong.

Do not use an adapter.

Do not use an extension cord.

Failure to follow these instructions can result in death, fire, or electrical shock.

- Turn knits inside out to prevent pilling. Separate lint-takers from lint-givers. Synthetics, knits, and corduroy fabrics will pick up lint from towels, rugs, and chenille fabrics.
- Do not dry garments if stains remain after washing because heat can set stains into fabric.
- Always read and follow fabric care labels and laundry product instructions. Improper usage may cause damage to your garments.

2. Add laundry products, if desired

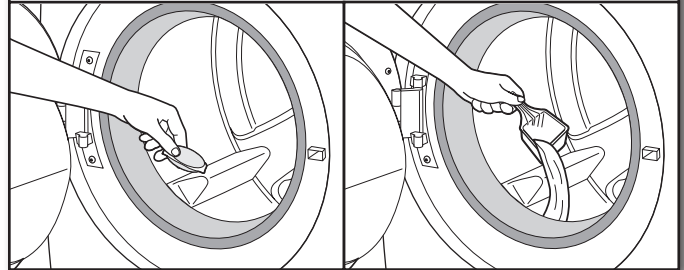

Single-dose laundry packets, Oxi-type boosters, color-safe bleach, or scented crystals can be added to the drum prior to adding laundry.

NOTE: Always follow manufacturer's instructions.

3. Load laundry into washer

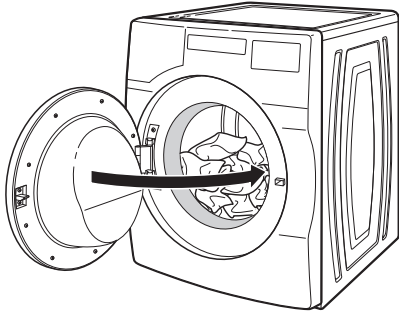

Place a load of sorted items loosely in the washer. Items need to move freely for best cleaning and to reduce wrinkling and tangling. Close the washer door by pushing it firmly until the latch clicks.

- Push load fully into the washer. Make sure no items are resting on the rubber seal to avoid trapping them between the seal and the door window.
- Mix large and small items and avoid washing single items. Load evenly.
- Wash small items in mesh garment bags. For multiple items, use more than one bag and fill bags equally.

4. Add HE detergent

Single Load Dispenser Drawer

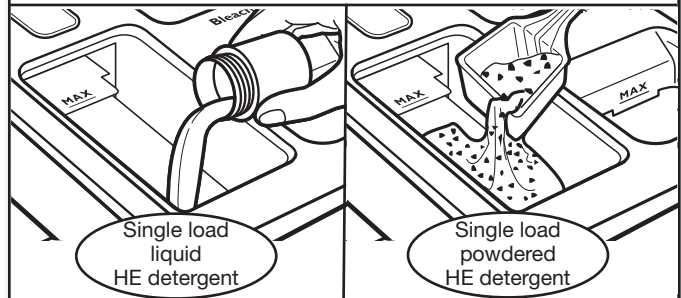

Adjust the selector, based on type of HE detergent used (either liquid or powdered). Add a measured amount of detergent directly into the detergent compartment. See the "Using the Dispensers" section.

NOTE: Do not add single-dose laundry packets, Oxi-type boosters, color-safe bleach, or scented crystals to dispensers. They will not dispense correctly.

5. Add liquid fabric softener to single load dispenser, if desired

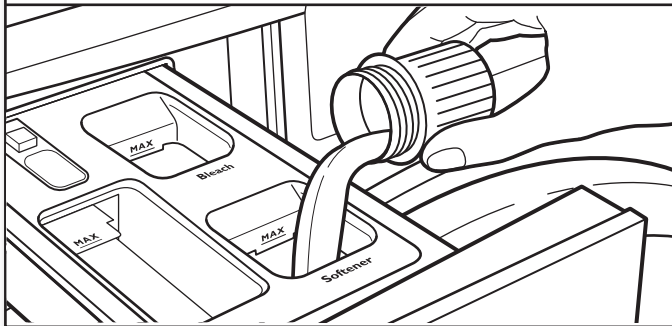

Pour a measured amount of liquid fabric softener into liquid fabric softener compartment. Always follow manufacturer's directions for correct amount of fabric softener, based on your load size.

Fabric softener is always dispensed in the last rinse, even if Extra Rinse is selected.

IMPORTANT: Do not overfill, dilute, or use more than the manufacturer-recommended quantity of fabric softener. Do not fill past the "MAX" line. Overfilling dispenser will cause fabric softener to immediately dispense into washer.

- Do not spill or drip any fabric softener onto the clothes.
- Do not use liquid fabric softener dispenser balls in this washer. They will not dispense correctly.
- Do not use fabric softener sheets, as they can stain the load.

6. Add liquid chlorine bleach to single load dispenser, if desired

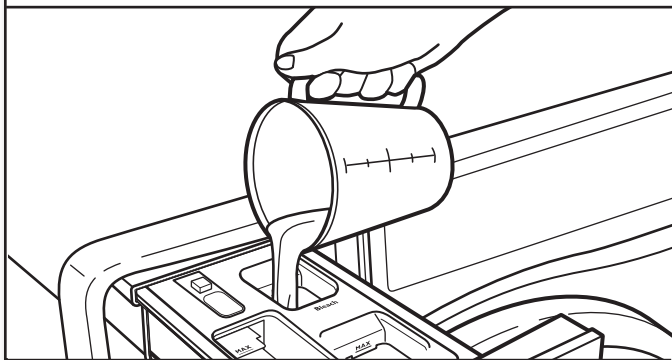

Add liquid chlorine bleach to the bleach compartment. Do not overfill, dilute, or use more than 2/3 cup (165 mL). Do not use color-safe bleach or Oxi in the same cycle with liquid chlorine bleach.

IMPORTANT:

- Always measure liquid chlorine bleach. Use a measuring cup with a pour spout; do not guess.
- Do not fill beyond the "MAX" line. Overfilling could cause garment damage.
- Do not use thickened, easy-pour, or no-splash bleach when running the Clean Washer with affresh® cycle, as excess suds may occur.
- Do not add liquid chlorine bleach to the bulk dispenser.
- Slowly close dispenser drawers. Make sure the drawers are closed completely.

7. Touch POWER to turn on washer

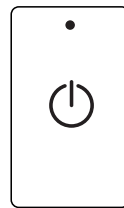

8. Select a wash program/cycle

REGULAR	DELICATES	BULKY ITEMS	WHITES	COLORS	TOWELS
NORMAL	WRINKLE CONTROL	HEAVY DUTY	SANITIZE with OXI	COLD WASH	QUICK

See the Cycle Guide for details on cycles features.

9. Adjust cycle modifiers, if desired*

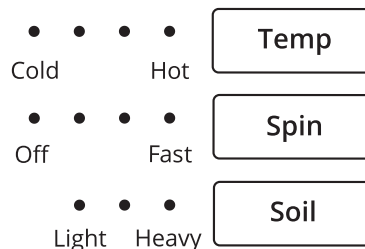

The led indicator lights will show the default settings for the selected cycle. To adjust a setting, touch its name – Temp, Spin, or Soil. Adjusting settings may change the Estimated Time Remaining. Tightly packing the load, unbalanced loads, or excessive suds may also cause the washer to increase the cycle time.

10. Select any additional options*

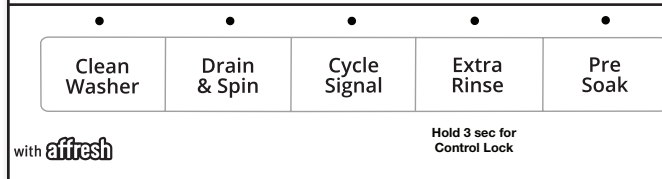

To add an option to the cycle, touch its name – Extra Rinse. To remove an option from the selected cycle, touch that button again.

* Not all options and settings are available with all cycles. See "Cycle Guide" for available options and settings.

11. Touch and hold START/PAUSE to begin wash cycle



Touch and hold START/PAUSE for 3 seconds to start the wash cycle. To pause a cycle in progress, touch START/PAUSE once; then touch and hold again to continue the cycle. To cancel a cycle, touch and hold POWER.

Once you touch and hold START/PAUSE, you will hear the door lock. The washer door will remain locked during the wash cycle.

Unlocking the door to add garments:

If you need to open the door to add one or two missed garments, you may do so while the “Add Garment” light is lit. The time allowed to add a garment will vary based on cycle selection and load size.



Touch START/PAUSE once; the door will unlock once the washer movement has stopped. This may take several minutes. Then close door and touch and hold START/PAUSE again to restart the cycle.

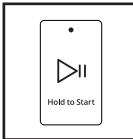

Adding items after “Add Garment” light is off:

Cancel current cycle. Water will drain and you will need to reselect cycle and restart.

For best wash performance and optimal energy savings, add garments only when the “Add Garment” light is on.

12. Remove garments promptly after cycle is finished

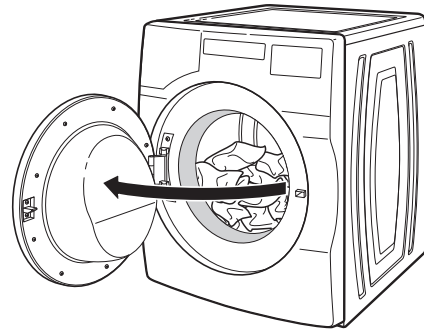

Promptly remove garments after cycle has completed to avoid odor and rusting of metal objects on garments. When unloading garments, pull back the door seal and check for small items between the tub and the washer drum.

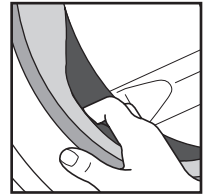

NOTES:

- A small amount of water may remain in the single load dispenser after the wash cycle is complete. This is normal.
- This washer has a tight seal to avoid water leaks. To avoid odors, leave the door open to allow the washer to dry between uses.

WASHER MAINTENANCE

WATER INLET HOSES

Replace inlet hoses after five years of use to reduce the risk of hose failure. Periodically inspect and replace inlet hoses if bulges, kinks, cuts, wear, or leaks are found.

When replacing your inlet hoses:

Mark the date of replacement on the label with a permanent marker.

Check that the old washers are not stuck on the washer inlet valves.

Use new washers in the new inlet hoses to ensure a proper seal.

WASHER CARE

Recommendations to Help Keep Your Washer Clean and Performing at Its Best

1. Always use High Efficiency (HE) detergents and follow the HE detergent manufacturer's instructions regarding the amount of HE detergent to use. Never use more than the recommended amount because that may increase the rate at which detergent and soil residue accumulate inside your washer which, in turn, may result in undesirable odor.
2. Use warm or hot water washes sometimes (not exclusively cold water washes) because they do a better job of controlling the rate at which soils and detergent accumulate.
3. Always leave the washer door slightly ajar between uses to help dry out the washer and avoid the buildup of odor-causing residue.
4. Periodically clean residue from all interior surfaces of the glass window. For better care, wipe the entire inside of the glass door with a damp cloth.

Cleaning Your Front Loading Washer

Read these instructions completely before beginning the routine cleaning processes recommended below. This washer maintenance procedure should be performed, at a minimum, once per month or every 30 wash cycles, whichever occurs sooner, to control the rate at which soils and detergent may otherwise accumulate in your washer.

Cleaning the Door Seal

1. Open the washer door and remove any clothing or items from the washer.
2. Inspect the gray-colored seal between the door opening and the drum for stained areas or soil buildup or lint. Pull back the seal to inspect all areas under the seal and to check for foreign objects or lint.
3. If stained areas or soil buildup, or lint are found, wipe down these areas of the seal using either of the following two procedures:
 - a. **affresh® Machine Cleaning Wipes Procedure:**
 - i. When the cycle is complete, gently pull back the rubber door seal and clean the entire surface with the textured side of an affresh® Machine Cleaning Wipe.
 - b. **Dilute Liquid Chlorine Bleach Procedure:**
 - i. Mix a dilute bleach solution, using 3/4 cup (177 mL) of liquid chlorine bleach and 1 gallon (3.8 L) of warm tap water.
 - ii. Wipe the seal area with the dilute solution, using a damp cloth.

WASHER CARE (cont.)

iii. Let stand 5 minutes.

iv. Wipe down area thoroughly with a dry cloth and let washer interior air dry with door open.

IMPORTANT:

- Wear rubber gloves when cleaning with bleach.
- Refer to the bleach manufacturer's instructions for proper use.

Cleaning the Inside of the Washer

This washer has a special cycle that uses higher water volumes in combination with affresh® Washer Cleaner or regular liquid chlorine bleach to thoroughly clean the inside of the washer. Steam washer models also utilize steam to enhance cleaning in this special cycle.

IMPORTANT: Do not use thickened, easy-pour, or no-splash bleach when running the Clean Washer with affresh® cycle as excess suds may occur.

NOTE: Read these instructions completely before beginning the cleaning process.

Begin procedure

1. Clean Washer with affresh® Cycle Procedure (Recommended for best performance):

- a. Open the washer door and remove any clothing or items.
 - b. Use an affresh® Machine Cleaning Wipe or a soft, damp cloth or sponge to clean the inside door window.
 - c. Add an affresh® Washer Cleaner tablet to the washer drum.
 - d. Do not add the affresh® Washer Cleaner tablet to the dispenser drawer.
 - e. Do not add any detergent or other chemical to the washer when following this procedure.
 - f. Close the washer door.
 - g. Select the Clean Washer with affresh® cycle.
- NOTE:** The washer remembers your last option selection and will use it for future wash cycles until you deselect that option.
- h. Touch and hold START to begin the cycle.
The Clean Washer with affresh® cycle operation is described below.

2. Chlorine Bleach Procedure:

- a. Open the washer door and remove any clothing or items.
- b. Open the single load dispenser drawer and add regular liquid chlorine bleach to the "MAX" line in both the bleach compartment and the fabric softener compartment. Either traditional or HE chlorine bleach can be used.

IMPORTANT: Do not use thickened, easy-pour, or no-splash bleach as excess suds may occur.

NOTE: Use of more liquid chlorine bleach than is recommended above could cause washer damage over time.

WASHER CARE (cont.)

- c. Close the washer door and the dispenser drawer.
- d. Do not add any detergent or other chemicals to the washer when following this procedure.
- e. Select the Clean Washer with affresh® cycle.
NOTE: The washer remembers your last option selection and will use it for future wash cycles until you deselect that option.
- f. Touch and hold START/PAUSE to begin the cycle. The Clean Washer with affresh® cycle operation is described below.

NOTE: For best results, do not interrupt cycle.

Description of Clean Washer with affresh® Cycle Operation:

1. The Clean Washer with affresh® cycle will determine whether clothing or other items are in the washer.
2. If no items are detected in the washer, it will proceed with the cycle.
 - a. If any items are detected in the washer, “rL” (remove load) will be displayed. The door will unlock. Open washer and remove any garments from the washer drum.
 - b. Touch POWER to clear the “rL” code.
 - c. Touch and hold START/PAUSE to restart the cycle.
3. **Steam models only:** During the first 20 minutes of the cycle, it will activate the steamer but the drum will not spin or fill with water. You may see condensation on the door window during this initial phase. If you are using an affresh® Washer Cleaner tablet, it will not dissolve completely during the steam phase. This is normal.

After the cycle is complete, leave the door open slightly to allow for better ventilation and drying of the washer interior.

Cleaning the Dispensers

After using the Clean Washer with affresh® cycle, you may find some residue buildup in the washer's dispensers.

To remove residue from the single load dispenser, remove the drawer and wipe the surfaces with an affresh® Machine Cleaning Wipe or a damp cloth and towel dry either before or after you run the Clean Washer with affresh® cycle. Use an all-purpose surface cleaner, if needed.

Replace the dispenser in the washer cabinet and make sure that it is correctly seated.

IMPORTANT: Dispensers are not dishwasher-safe.

Cleaning the Outside of the Washer

Use an affresh® Machine Cleaning Wipe or a soft, damp cloth or sponge to wipe up any spills. Occasionally wipe the outside of your washer to help keep it looking new. Use an affresh® Machine Cleaning Wipe or mild soap and water.

IMPORTANT: To avoid damaging the washer's finish, do not use abrasive products.

CLEAN WASHER CYCLE REMINDER

NOTE: Not all models have the Clean Washer with affresh® cycle reminder light.

The Clean Washer with affresh® LED will flash at the end of a wash cycle when the washer has run 30 wash cycles. This is a reminder to run the Clean Washer with affresh® cycle.

If the Clean Washer with affresh® cycle is not turned on, the LED will stop flashing at the end of a wash cycle after running three more regular wash cycles. After 30 more wash cycles are completed, the Clean Washer with affresh® LED will again flash at the end of a wash cycle as a reminder.

REMOVING THE DISPENSER (cont.)

Single Load Dispenser Drawer

Removing the Dispenser

To remove:

1. Pull dispenser drawer out until it stops.
2. Press down on the release tab and pull straight out to remove the dispenser.

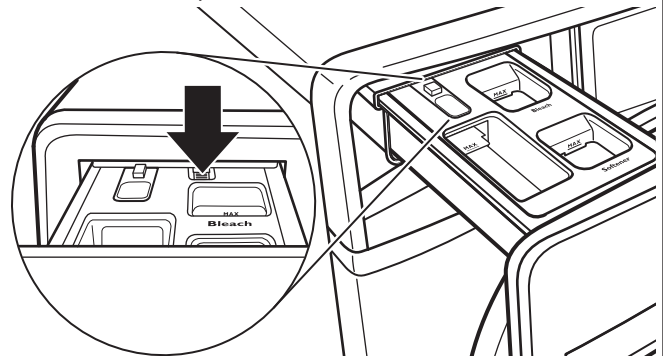

3. Lift off cover panel by pulling straight up.

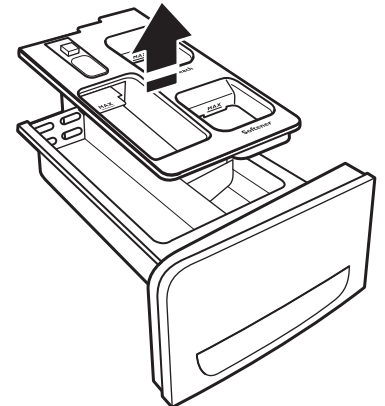

To replace:

1. Position cover panel back onto posts on dispenser. Apply slight pressure on cover panel to seat it.
2. Align edges of dispenser with guides in washer; then slide dispenser back into slot.

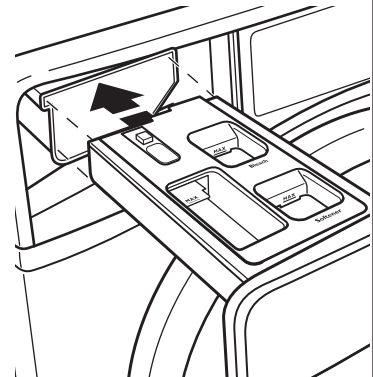

NON-USE AND VACATION CARE

Operate your washer only when you are home. If moving or not using your washer for a period of time, follow these steps:

1. Unplug or disconnect power to washer.
2. Turn off water supply to washer to avoid flooding due to water pressure surges.

HELPFUL TIP: Attach a reminder note to the washer to turn the water back on before washer's next use.

3. Clean the dispensers. See "Cleaning the Dispensers."

WINTER STORAGE CARE

IMPORTANT: To avoid damage, install and store washer where it will not freeze. Because some water may stay in hoses, freezing can damage washer. If storing or moving during freezing weather, winterize your washer.

To winterize washer:

1. Shut off both water faucets; then disconnect and drain water inlet hoses.

HELPFUL TIP: Attach a reminder note to the washer to turn the water back on before washer's next use.

2. Put 1 qt. (1 L) of R.V.-type antifreeze in washer drum and run washer on Normal cycle for about 2 minutes to mix antifreeze and remaining water.
3. Unplug washer or disconnect power.

TRANSPORTING YOUR WASHER

1. Shut off both water faucets. Disconnect and drain water inlet hoses.
2. If washer will be moved during freezing weather, follow "Winter Storage Care" directions before moving.
3. Disconnect drain hose from drain system and from back of washer.
4. Unplug power cord.
5. Place inlet hoses and drain hose inside washer drum.
6. Bundle power cord with a rubber band or cable tie to keep it from hanging to the ground.

IMPORTANT: Call for service to install new transport bolts. Do not reuse transport bolts. Washer must be transported in the upright position. To avoid structural damage to your washer, it must be properly set up for relocation by a certified technician.

⚠ WARNING



Electrical Shock Hazard

Plug into a grounded 3 prong outlet.

Do not remove ground prong.

Do not use an adapter.

Do not use an extension cord.

Failure to follow these instructions can result in death, fire, or electrical shock.

REINSTALLING/USING WASHER AGAIN

To reinstall washer after non-use, vacation, winter storage, or moving:

1. Refer to Installation Instructions to locate, level, and connect washer.
2. Before using again, run washer through the following recommended procedure:

To use washer again:

1. Flush water pipes and hoses. Reconnect water inlet hoses. Turn on both water faucets.
2. Plug in washer or reconnect power.
3. Run washer through Heavy Duty cycle to clean washer and remove antifreeze, if used. Use only HE detergent. Use half the manufacturer's recommended amount for a medium-size load.

ADDITIONAL CLEANING

Gently pull back the rubber door seal and clean any stained areas, soil buildup, or lint with the textured side of an affresh® Machine Cleaning Wipe.

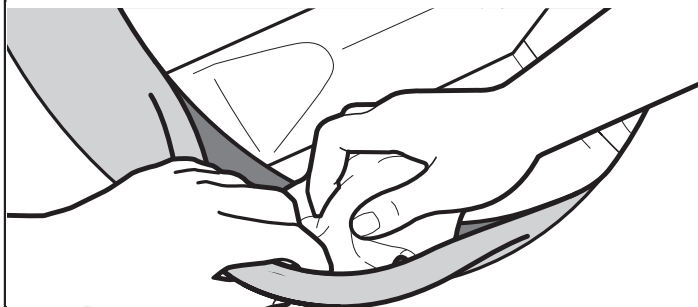

TROUBLESHOOTING

First try the solutions suggested here or visit our website at www.amana.com
(in Canada www.amanacanada.ca) for assistance and to possibly avoid a service call.

If you experience	Possible Causes	Solution
Error Code Appears in Display (for 2- and 3-digit displays)		
Once any possible issues are corrected, touch POWER once to clear the code. Reselect and restart the cycle.		
"Sd" or "SUD" (excess suds) appears in display	Excessive suds in washer. Washer is running a suds reduction routine.	Allow the washer to continue. Use only HE detergent. Always follow the detergent manufacturer's instructions to determine the amount of detergent to use, and base detergent quantity on load size. Not all detergents labeled as High Efficiency are identical in formulation and their ability to reduce suds. For example, natural, organic, or homemade HE detergents may generate a high level of suds. If you use one of these and see a "SUD" error code appear in the display, consider using a different HE detergent.
"Lo" "FL" appears on display, or F8 E1 or "Lo" "FL" appears on display, or F08 E01 (water supply error) appears in display	Check for proper water supply.	Unit will drain for 8 minutes while door remains locked. The drain cycle must be allowed to complete, or the error code cannot reset. When complete, touch POWER once to clear the code. Then touch POWER again and restart the washer. If code appears again, call for service.
		Both hoses must be attached and have water flowing to the inlet valve.
		Both hot and cold water faucets must be on.
F9 followed by E1 or F09 followed by E01 (drain pump system error) appears in display	Check for proper inlet hoses.	Use only manufacturer's recommended inlet hoses.
	Check plumbing for correct drain hose installation. Drain hose extends into standpipe farther than 4½" (114 mm).	Ensure top of drain pipe is installed at least 39" above the floor. Ensure drain hose extends no farther than 4½" into standpipe.
		Check drain hose for proper installation.
		Make sure the drain hose is not kinked, pinched, or blocked.
		Remove any clogs from drain hose.
		Use drain hose form and securely attach to drainpipe or tub.
Lower drain hose if the end is higher than 96" (2.4 m) above the floor.		
Ensure drain hose extends no farther than 4½" into standpipe.		
Not using HE detergent or using too much HE detergent.	Use only HE detergent. Always measure detergent and follow manufacturer's directions based on load size and soil level.	
F5 followed by E2 or F05 followed by E02 (door will not lock) appears in display	Washer door not locking.	Touch POWER to cancel the cycle. Check that the door is closed completely and latching. Check for items in the washer drum that may be keeping the door from closing completely.
Err	Invalid action performed.	This error code will be shown in the following conditions: 1. Trying to start a cycle with the door open. 2. Trying to select a different cycle while you're already running one. No further action is needed to correct this.

TROUBLESHOOTING

First try the solutions suggested here or visit our website at www.amana.com
(in Canada www.amanacanada.ca) for assistance and to possibly avoid a service call.

If you experience	Possible Causes	Solution
Error Code Appears in Display (for 2- and 3-digit displays) (cont.)		
"rL" (remove load) appears in display	Load detected in drum during Clean Washer with affresh® cycle.	Remove items from washer drum and restart Clean Washer with affresh® cycle.
Loc	Control is locked.	This is not an error code but just an indication that the control is locked. Press and hold the control lock key for three seconds to unlock.

⚠ WARNING



Electrical Shock Hazard

Plug into a grounded 3 prong outlet.

Do not remove ground prong.

Do not use an adapter.

Do not use an extension cord.

Failure to follow these instructions can result in death, fire, or electrical shock.

F# E# or F## E## code other than as described above appears in display	System error code.	Touch POWER once to clear the code. Then touch POWER again and restart the washer. If code appears again, call for service. Unplug washer for 30 seconds; then plug back in.
Washer making error beeps	Door has not been opened and closed for at least three cycles.	This code may occur when the washer is first turned on. Open and close the door to clear the display.
Washer beeps when Start/ Pause is touched	Door not closed.	Close the door completely.
CL appears on display, or Clean Washer LED flashing at end of wash cycle (on some models)	The washer has run 30 wash cycles and is indicating a reminder to run the Clean Washer with affresh® cycle.	Run the Clean Washer with affresh® cycle. If the Clean Washer with affresh® cycle is not turned on, the LED will stop flashing at the end of a wash cycle after running three more regular wash cycles. After 30 more wash cycles are completed, the Clean Washer with affresh® LED will again flash at the end of a wash cycle as a reminder.
Washer won't start	Control lock could be enabled.	To check whether the unit is in control lock, try powering On the unit. On doing that if you see the code 'Loc' displayed in the seven segment display, then you know that control is locked. To unlock controls press and hold the 'control lock' key for three seconds. Be sure the door is closed. Make sure you press and hold the start button for 1 full second. Make sure the door has been opened and closed since the last cycle was run.
"PF"	Appears upon recovery from power loss, if power was lost while running a cycle.	Touch POWER once to clear the code. Then touch POWER again and restart the washer.
F0 E5 or "ob"	Off balance load detected. This means that your washer detected an off balance load and that caused the cycle to take longer than usual or the clothes to be more wet than usual.	Touch POWER once to clear the code. Then touch POWER again and restart the washer.
"dr" or F5 E4	Door not opened between cycles.	Open and close the door. Touch POWER once to clear the code. Then touch POWER again and restart the washer.

TROUBLESHOOTING

First try the solutions suggested here or visit our website at www.amana.com
(in Canada www.amanacanada.ca) for assistance and to possibly avoid a service call.

If you experience	Possible Causes	Solution
Vibration or Off-Balance		
Vibration, rocking, or "walking"	Feet may not be in contact with the floor and locked.	Front and rear feet must be in firm contact with floor, and washer must be level to operate properly. Jam nuts must be tight against the bottom of the cabinet.
	Washer may not be level.	Check floor for flexing or sagging. If flooring is uneven, a 3/4" (19 mm) piece of plywood under your washer will reduce sound. Do not install washer on a raised wooden platform. See "Level the Washer" in Installation Instructions.
	Load could be unbalanced or too large.	Avoid tightly packing the load. Avoid washing single items. Balance a single item such as a rug or jeans jacket with a few extra items. Item or load not suitable for selected cycle. See "Cycle Guide" and "Using Your Washer."
	The shipping bolts are still in the back of the washer.	See "Remove transport bolts from washer" in the Installation Instructions.
Noises		
Clicking or metallic noises	Door locking or unlocking.	After starting a cycle the drum will make a partial turn and the door will lock. The door will remain locked until the end of the cycle. This is normal.
	Objects caught in washer drain system.	Empty pockets before washing. Loose items such as coins could fall between washer drum and tub or may block pump. It may be necessary to call for service to remove items. It is normal to hear metal items on clothing such as metal snaps, buckles, or zippers touch against the stainless steel drum.
Gurgling or humming	Washer may be draining water.	The pump may make a humming sound with periodic gurgling or surging as final amounts of water are removed during the spin/drain cycles. This is normal at certain stages of the cycle.
Rolling or sloshing and occasional clicking (on slow-speed spin)	Steel balls in the balancing system are balancing the load.	This is normal at certain stages of the cycle.
Water Leaks		
Check the following for proper installation	Fill hoses not attached tightly.	Tighten fill-hose connection.
	Fill hose washers.	Properly seat all four fill-hose flat washers.
	Drain hose connection.	Check that the drain hose is properly secured to drainpipe or laundry tub.
	One some models: Drain pump filter is not properly seated.	One some models: Make sure filter is correctly placed in the housing. See "Cleaning the Drain Pump Filter/Draining Residual Water."
	Check household plumbing for leaks or clogged sink or drain.	Water can back up out of a clogged sink or drainpipe. Check all household plumbing for leaks (laundry tubs, drain pipe, water pipes, and faucets.)
Strainer (or nylon stocking) on end of drain hose is clogged.	Remove strainer/stocking from drain hose.	

TROUBLESHOOTING

First try the solutions suggested here or visit our website at www.amana.com
(in Canada www.amanacanada.ca) for assistance and to possibly avoid a service call.

If you experience	Possible Causes	Solution
Water Leaks (cont.)		
Water or suds leaking from door or rear of cabinet	Not using HE detergent or using too much HE detergent.	Only use HE detergent. Suds from regular detergents can cause leaking from the door or rear of cabinet. Always measure detergent and follow manufacturer's directions based on your load requirements.
	Using thickened, easy-pour, or no-splash bleach when running the Clean Washer with affresh® cycle.	Use affresh® tablet or regular, non-thickened chlorine bleach when running the Clean Washer with affresh® cycle.
	Residue on door window.	Periodically clean the underside of the window to avoid potential leaks.
	Door opened during "Add Garment."	Water can drip off the inside of the door when the door is opened after the start of a cycle.
Leaking around door	Hair, lint, or other debris on inner door window preventing proper seal with rubber door seal.	Clean inner door window and seal. See "Cleaning the Door Seal" in the "Washer Maintenance" section.
Washer Not Performing As Expected		
Load not completely covered in water	Water level not visible on door or does not cover clothes.	This is normal for an HE front-load washer. The washer senses load sizes and adds the correct amount of water for optimal cleaning.
Washer won't run or fill; washer stops working	Check for proper water supply.	Both hoses must be attached and have water flowing to the inlet valve.
		Both hot and cold water faucets must be turned on.
		Check that inlet valve screens have not become clogged.
		Check for any kinks in inlet hoses, which can restrict water flow.

⚠ WARNING



Electrical Shock Hazard

Plug into a grounded 3 prong outlet.

Do not remove ground prong.

Do not use an adapter.

Do not use an extension cord.

Failure to follow these instructions can result in death, fire, or electrical shock.

Washer won't run or fill; washer stops working (cont.)	Check proper electrical supply.	Plug power cord into a grounded 3 prong outlet.
		Do not use an extension cord.
		Ensure there is power to outlet.
		Do not plug into a GFCI (Ground Fault Circuit Interrupter).
		Check electrical source or call an electrician to check if voltage is low.
		Reset a tripped circuit breaker. Replace any blown fuses.
		NOTE: If problems continue, contact an electrician.

TROUBLESHOOTING

First try the solutions suggested here or visit our website at www.amana.com
(in Canada www.amanacanada.ca) for assistance and to possibly avoid a service call.

If you experience	Possible Causes	Solution
Washer Not Performing As Expected (cont.)		
Washer won't run or fill; washer stops working (cont.)	Normal washer operation.	Door must be completely closed and latched for washer to run.
		The washer pauses for about 2 minutes during certain cycles. Allow the cycle to continue. Some cycles feature periods of tumbling and soak.
		Washer may be stopped to reduce suds. Use only a proper amount of HE detergent.
		Cold Wash uses less water in the beginning of the cycle to provide a high concentration of detergent for optimal cleaning action. Following this concentrated tumbling, more water is used to complete the wash.
		During the first 20 minutes of the Clean Washer with affresh® cycle, it will activate the steamer but the drum will not spin or fill with water. You may see condensation on the door window during this initial phase. If you are using an affresh® Washer Cleaner tablet, it will not dissolve completely during the steam phase. This is normal.
	The washer door is not firmly shut.	The door must be closed during operation.
	Washer not loaded as recommended.	Remove several items and rearrange load evenly in washer drum. Close door; then touch and hold START/PAUSE.
		Do not add more than one or two additional items after cycle has started to avoid tightly packing or unbalancing.
Do not add more water to the washer.		
Not using HE detergent or using too much HE detergent.	Only use HE detergent. Suds from regular detergents can slow or stop the washer. Always measure detergent, following manufacturer's directions based on your load requirements.	
	To remove suds, cancel cycle. Select DRAIN & SPIN with EXTRA RINSE. Touch START/PAUSE. Do not add more detergent.	
Door not opened between cycles.	After any wash cycle is completed, the door must be opened and then closed before a new cycle can begin.	
Washer not draining/spinning; loads are still wet	Drain hose extends into standpipe farther than 4.5" (114 mm).	Check drain hose for proper installation. Use drain hose form and securely attach to drainpipe or tub. Do not tape over drain opening.
	The drain hose is clogged, or the end of the drain hose more than 96" (2.4 m) above the floor.	Lower drain hose if the end is higher than 96" (2.4 m) above the floor. Remove any clogs from drain hose. See "Installation Requirements" in Installation Instructions.
	Strainer/stocking on end of drain hose.	Remove strainer/stocking from drain hose.
	The drain hose fits too tightly in the standpipe, or it is taped to the standpipe.	The drain hose should be loose yet fit securely. Do not seal the drain hose with tape. The hose needs an air gap. See "Secure the Drain Hose" in Installation Instructions.

TROUBLESHOOTING

First try the solutions suggested here or visit our website at www.amana.com
(in Canada www.amanacanada.ca) for assistance and to possibly avoid a service call.

If you experience	Possible Causes	Solution
Washer Not Performing As Expected (cont.)		
Washer not draining/spinning; loads are still wet (cont)	Using cycles with a slower spin speed.	Cycles with slower spin speeds remove less water than cycles with fast spin speeds. Use the recommended cycle/speed spin for your garment.
	Washer not loaded as recommended.	A tightly packed or unbalanced load may not allow the washer to spin correctly, leaving the load wetter than normal. See the Cycle Guide for load size recommendation for each cycle.
	The load may be out of balance.	Avoid washing single items. Balance a single item, such as a rug or jeans jacket with a few extra items.
	Not using HE detergent or using too much HE detergent.	Use only HE detergent. Suds from regular detergent or using too much detergent can slow or stop draining or spinning. Always measure and follow manufacturer's directions for your load. To remove extra suds, select DRAIN & SPIN with EXTRA RINSE. Do not add detergent.
	Small items may have been caught in the pump or stuck between the washer drum and the outer tub.	Check the drum for any items sticking through the drum holes. Empty pockets and use garment bags when washing small items.
	There are too many clothes in the Wash & Dry cycle.	Only use the Wash & Dry cycle for two to four lightly soiled synthetic garments, athletic uniforms, or workout wear.
	One some models: Drain pump filter is dirty.	One some models: Clean drain pump filter. See "Cleaning the Drain Pump Filter/Draining Residual Water."
Washer is spinning clothes without water	The washer is measuring the mass of the dry load.	This measurement is normal and ensures the best cycle time for your load.
Door locked at end of wash cycle	Water remaining in washer after cycle.	Select DRAIN & SPIN to remove any water remaining in the washer. The washer door will unlock at the end of the drain.
Door will not unlock	Door locks when cycle has started.	If the "Add Garment" light is lit, touch START/PAUSE once. The door will unlock.
Incorrect or wrong wash or rinse temperatures	Check for proper water supply.	Make sure hot and cold inlet hoses are not reversed.
		Both hoses must be attached to both washer and faucet, and have both hot and cold water flowing to inlet valve.
		Check that inlet valve screens are not clogged.
	Remove any kinks in hoses.	
Washing many loads.	Your hot water tank may not have enough hot water to keep up with the number of hot or warm washes. This is normal.	
Desired setting or option does not light	For best performance, not all settings are available with each cycle, and some options cannot be used together.	See the "Cycle Guide" for the available settings and options for each cycle.
Load not rinsed	Check for proper water supply.	Make sure hot and cold inlet hoses are not reversed.
		Both hoses must be attached and have water flowing to the inlet valves.
		Both hot and cold water faucets must be on.
		Inlet valve screens on washer may be clogged.
		Remove any kinks in the inlet hoses.
	Not using HE detergent or using too much HE detergent.	The suds from non-HE detergent can cause the washer to operate incorrectly. Use only HE detergent. Always measure detergent and follow manufacturer's directions based on load size and soil level.

TROUBLESHOOTING

First try the solutions suggested here or visit our website at www.amana.com
(in Canada www.amanacanada.ca) for assistance and to possibly avoid a service call.

If you experience	Possible Causes	Solution
Washer Not Performing As Expected (cont.)		
Load not rinsed (cont.)	Washer not loaded as recommended.	<p>Avoid tightly packing the washer. The washer will not rinse well if tightly packed. Load with dry items only. See the “Cycle Guide” for load size recommendations for each cycle.</p> <p>Use cycle designed for the fabrics being washed.</p> <p>Add only one or two garments after washer has started.</p>
	The load may be out of balance.	When load imbalance occurs, a washing process will start to redistribute the load. This may lengthen the cycle time. Avoid washing single items. Balance a single item, such as a rug or jeans jacket, with a few extra items.
Load is wrinkled, twisted, or tangled	Washer not loaded as recommended.	<p>Add load loosely. Items need to move freely to reduce wrinkling and tangling. See “Cycle Guide” for load size recommendations for each cycle.</p> <p>Reduce tangling by mixing types of load items. Use the recommended cycle for the type of garments being washed.</p>
	Wash action too long for load.	Select a lower soil level. Note that items will not be cleaned as deeply as when using a higher soil level.
	Spin speed too fast for load.	Select a slower spin speed. Note that items will be wetter than when using a faster spin speed.
	The washer is not unloaded promptly.	Unload the washer as soon as it stops.
	Not choosing the right cycle for the load being washed.	Use the Delicates cycle or another cycle with a slow spin speed to reduce wrinkling.
	The wash water was not warm enough to relax wrinkles.	If safe for load, use warm or hot wash water.
Not cleaning or removing stains	Washer not loaded as recommended.	<p>Add load loosely. Items need to move freely for best cleaning. “Cycle Guide” for load size recommendations for each cycle.</p> <p>Add only one or two garments after washer has started.</p>
	Not using HE detergent or using too much HE detergent.	Use only HE detergent. Always measure detergent and follow manufacturer’s directions based on load size and soil level.
	Hard water or high level of iron (rust) in water.	You may need to install a water softener and/or iron filter.
	Fabric softener dispensing ball used.	Dispensing balls will not operate correctly with this washer. Add liquid fabric softener to the fabric softener compartment.
	Powdered detergent used for slow-speed cycle.	Consider using liquid detergent.

TROUBLESHOOTING

First try the solutions suggested here or visit our website at www.amana.com
(in Canada www.amanacanada.ca) for assistance and to possibly avoid a service call.

If you experience	Possible Causes	Solution
Washer Not Performing As Expected (cont.)		
Not cleaning or removing stains (cont.)	Not using correct cycle for fabric type.	Use a higher soil level setting and warmer wash temperature to improve cleaning.
		If using Quick Wash cycle, wash only a few items.
		Use Whites and Heavy Duty cycles for tough cleaning.
		Add an extra rinse for heavily soiled loads.
	Not using dispensers.	Use dispensers to avoid chlorine bleach and fabric softener staining.
		Load dispensers before starting a cycle.
		Avoid overfilling.
Do not add products other than those specified directly to load.		
Dispense cartridge is empty.	Fill dispense cartridge to the "MAX" line with HE liquid detergent.	
Detergent dispenser is not securely in place.	Pull out the dispenser, fill with detergent, and slide it back in place.	
Not washing like colors together.	Wash like colors together and remove promptly after the cycle is complete to avoid dye transfer.	
Not enough detergent used, or hard water.	Use more detergent for washing heavy soils in cold or hard water.	
Odors	Monthly maintenance not done as recommended.	Run the Clean Washer with affresh® cycle monthly or every 30 wash cycles. See "Washer Care" in the "Washer Maintenance." section.
		Unload washer as soon as cycle is complete.
	Not using HE detergent or using too much HE detergent.	Use only HE detergent. Be sure to measure correctly. Always follow the manufacturer's directions. See the "Washer Care" section.
Door not left open after use.	This washer has a tight seal to avoid water leaks. To avoid odors, leave the door open to allow the washer to dry between uses.	
Fabric damage	Sharp items were in pockets during wash cycle.	Empty pockets, zip zippers, and snap or hook fasteners before washing to avoid snags and tears.
	Strings and straps could have tangled.	Tie all strings and straps before starting wash load.
	Items may have been damaged before washing.	Mend rips and broken threads in seams before washing.
	Fabric damage can occur if washer is tightly packed.	Avoid tightly packing the washer. Load with dry items only.
		Use cycle designed for the fabrics being washed.
		Add only one or two garments after washer has started.
	Fabric damage can occur if washer door is closed on an item, trapping it between the door window and the rubber seal.	Do not overfill the washer.
		Push wash load fully into the washer.
Liquid chlorine bleach may have been added incorrectly.	Do not pour liquid chlorine bleach directly onto load. Wipe up bleach spills.	
	Undiluted bleach will damage fabrics. Do not use more than recommended by manufacturer.	

TROUBLESHOOTING

First try the solutions suggested here or visit our website at www.amana.com
(in Canada www.amanacanada.ca) for assistance and to possibly avoid a service call.

If you experience	Possible Causes	Solution
Washer Not Performing As Expected (cont.)		
Gray whites, dingy colors	Load not sorted properly.	The transfer of dye can occur when mixing whites and colors in a load. Sort dark clothes from whites and lights.
	Wash temperatures too low.	Use hot or warm temperatures if safe for the load. Make sure your hot water system is adequate to provide a hot water wash.
	Not enough detergent used, or hard water.	Use more detergent for washing heavy soils in cold or hard water.
Incorrect dispenser operation	Clogged dispensers or laundry products dispensing too soon.	Do not overfill dispenser. Overfilling causes immediate dispensing.
		Load dispensers before starting a cycle.
		Homes with low water pressure may result in residual powder in the dispenser. To avoid, select a warmer wash temperature if possible, depending on your load.
	Liquid chlorine bleach not used in bleach compartment.	Use only liquid chlorine bleach in the bleach compartment.
	Water in dispenser after cycle has finished.	It is normal for small amounts of water to remain in dispenser at the end of the cycle.
Single-dose laundry packet not dissolving	Adding laundry packet incorrectly.	Be sure laundry packet is added to washer drum before adding clothes. Do not add packet to dispenser. Follow the manufacturer's instructions to avoid damage to your garments.
Cycle time changes or cycle time too long	Normal washer operation.	The cycle times vary automatically based on your water pressure, water temperature, detergent, and clothes load. The options you select will also affect the cycle times.
	Excessive suds in washer.	When excessive suds are detected, a special suds routine automatically starts to remove extra suds and ensure proper rinsing of your garments. This routine will add time to the original cycle.
	Load may be out of balance.	When load unbalance occurs, a washing process will start to redistribute the load. This extends the cycle time. Avoid washing single items. Balance a single item such as a rug or jeans jacket with a few extra items.
	Not using correct cycle for load type.	The Quick Wash cycle is designed for smaller load sizes (2-4 items) of lightly soiled garments. If larger loads are washed in this cycle, cycle time will be increased.
When using the Quick Wash or Delicates cycle, you should wash small loads. This ensures a gentle wash for your garments without increasing cycle time.		
The controls are not responding	Control Lock is On.	Touch and hold CONTROL LOCK for 3 seconds to turn off Control Lock. For each second Control Lock is held down, the display will count down one second: you will see "3," then "2," then "1."

AMANA® MAJOR APPLIANCE LIMITED WARRANTY

ATTACH YOUR RECEIPT HERE. PROOF OF PURCHASE IS REQUIRED TO OBTAIN WARRANTY SERVICE.

Please have the following information available when you call the Customer eXperience Center:

- Name, address, and telephone number
- Model number and serial number
- A clear, detailed description of the problem
- Proof of purchase, including dealer or retailer name and address

IF YOU NEED SERVICE:

1. Before contacting us to arrange service, please determine whether your product requires repair. Some questions can be addressed without service. Please take a few minutes to review the Troubleshooting section of the Use and Care Guide or visit producthelp.amana.com.
2. All warranty service is provided exclusively by our authorized Amana Service Providers. In the U.S. and Canada, direct all requests for warranty service to:

Amana Customer eXperience Center

In the U.S.A., call 1-800-843-0304. In Canada, call 1-800-807-6777.

If outside the 50 United States or Canada, contact your authorized Amana dealer to determine whether another warranty applies.

ONE YEAR LIMITED WARRANTY

WHAT IS COVERED

For one year from the date of purchase, when this major appliance is installed, operated, and maintained according to instructions attached to or furnished with the product, Amana brand of Whirlpool Corporation or Whirlpool Canada LP (hereafter "Amana") will pay for factory specified replacement parts and repair labor to correct defects in materials or workmanship that existed when this major appliance was purchased or, at its sole discretion, replace the product. In the event of product replacement, your appliance will be warranted for the remaining term of the original unit's warranty period.

YOUR SOLE AND EXCLUSIVE REMEDY UNDER THIS LIMITED WARRANTY SHALL BE PRODUCT REPAIR AS PROVIDED HEREIN. Service must be provided by a Amana designated service company. This limited warranty is valid only in the United States or Canada and applies only when the major appliance is used in the country in which it was purchased. This limited warranty is effective from the date of original consumer purchase. Proof of original purchase date is required to obtain service under this limited warranty.

WHAT IS NOT COVERED

1. Commercial, non-residential, multiple-family use, or use inconsistent with published user, operator, or installation instructions.
2. In-home instruction on how to use your product.
3. Service to correct improper product maintenance or installation, installation not in accordance with electrical or plumbing codes, or correction of household electrical or plumbing (e.g., house wiring, fuses, or water inlet hoses).
4. Consumable parts (e.g., light bulbs, batteries, air or water filters, preservation solutions).
5. Defects or damage caused by the use of non-genuine Amana parts or accessories.
6. Conversion of products from natural gas or propane gas.
7. Damage from accident, misuse, abuse, fire, floods, acts of God, or use with products not approved by Amana.
8. Repairs to parts or systems to correct product damage or defects caused by unauthorized service, alteration, or modification of the appliance.
9. Cosmetic damage including scratches, dents, chips, and other damage to the appliance finishes, unless such damage results from defects in materials and workmanship and is reported to Amana within 30 days.
10. Discoloration, rust, or oxidation of surfaces resulting from caustic or corrosive environments including, but not limited to, high salt concentrations, high moisture or humidity, or exposure to chemicals.
11. Food or medicine loss due to product failure.
12. Pickup or delivery. This product is intended for in-home repair.
13. Travel or transportation expenses for service in remote locations where an authorized Amana servicer is not available.
14. Removal or reinstallation of inaccessible appliances or built-in fixtures (e.g., trim, decorative panels, flooring, cabinetry, islands, countertops, drywall) that interfere with servicing, removal, or replacement of the product.
15. Service or parts for appliances with original model/serial numbers removed, altered, or not easily determined.

The cost of repair or replacement under these excluded circumstances shall be borne by the customer.

DISCLAIMER OF IMPLIED WARRANTIES

IMPLIED WARRANTIES, INCLUDING ANY IMPLIED WARRANTY OF MERCHANTABILITY OR IMPLIED WARRANTY OF FITNESS FOR A PARTICULAR PURPOSE, ARE LIMITED TO ONE YEAR OR THE SHORTEST PERIOD ALLOWED BY LAW. Some states and provinces do not allow limitations on the duration of implied warranties of merchantability or fitness, so this limitation may not apply to you. This warranty gives you specific legal rights, and you also may have other rights that vary from state to state or province to province.

DISCLAIMER OF REPRESENTATIONS OUTSIDE OF WARRANTY

Amana makes no representations about the quality, durability, or need for service or repair of this major appliance other than the representations contained in this warranty. If you want a longer or more comprehensive warranty than the limited warranty that comes with this major appliance, you should ask Amana or your retailer about buying an extended warranty.

LIMITATION OF REMEDIES: EXCLUSION OF INCIDENTAL AND CONSEQUENTIAL DAMAGES

YOUR SOLE AND EXCLUSIVE REMEDY UNDER THIS LIMITED WARRANTY SHALL BE PRODUCT REPAIR AS PROVIDED HEREIN. AMANA SHALL NOT BE LIABLE FOR INCIDENTAL OR CONSEQUENTIAL DAMAGES. Some states and provinces do not allow the exclusion or limitation of incidental or consequential damages, so these limitations and exclusions may not apply to you. This warranty gives you specific legal rights, and you also may have other rights that vary from state to state or province to province.

05/17

ASSISTANCE OR SERVICE

Before calling for assistance or service, please check "Troubleshooting" or visit www.whirlpool.com/product_help. It may save you the cost of a service call. If you still need help, follow the instructions below.

When calling, please know the purchase date and the complete model and serial number of your appliance. This information will help us to better respond to your request.

If you need replacement parts or to order accessories

We recommend that you use only FSP® Factory Specified Parts.

These parts will fit right and work right because they are made with the same precision used to build every new Amana, Admiral, Estate, Inglis, or Roper brands of Whirlpool Corporation or Whirlpool Canada LP appliance.

To locate FSP® replacement parts, assistance in your area, or accessories:

Whirlpool Corporation Customer eXperience Center
**800-843-0304 for Amana, 800-688-9920 for Admiral,
800-253-1301 for Estate, or 800-447-6737 for Roper**
800-442-9991 (Accessories)
www.whirlpool.com/accessories

Whirlpool Canada LP
Customer eXperience Centre
**800-807-6777 for
Amana, Admiral, Estate, Inglis, & Roper**
www.whirlpoolappliances.ca

or call your nearest designated service center or refer to your Yellow Pages telephone directory.

Our consultants provide assistance with

In the U.S.A.

- Features and specifications on our full line of appliances.
- Installation information.
- Specialized customer assistance (Spanish speaking, hearing impaired, limited vision, etc.).

In the U.S.A. and Canada

- Use and maintenance procedures.
- Accessory and repair parts sales.
- Referrals to local dealers, repair parts distributors, and service companies. Whirlpool designated service technicians are trained to fulfill the product warranty and provide after-warranty service, anywhere in the United States and Canada.

You can write with any questions or concerns at:

Whirlpool Corporation
Customer eXperience Center
553 Benson Road
Benton Harbor, MI 49022-2692

Customer eXperience Centre
Whirlpool Canada LP
Unit 200-6750 Century Ave
Mississauga, Ontario L5N 0B7

Please include a daytime phone number in your correspondence.

ASSISTANCE OU SERVICE

Avant de faire un appel pour assistance ou service, veuillez vérifier la section "Dépannage" ou consulter www.whirlpool.com/product_help. Cette vérification peut vous faire économiser le coût d'une visite de réparation.

Si vous avez encore besoin d'aide, suivre les instructions ci-dessous.

Lors d'un appel, veuillez connaître la date d'achat et les numéros au complet de modèle et de série de votre appareil. Ces renseignements nous aideront à mieux répondre à votre demande.

Si vous avez besoin de pièces de rechange ou pour commander des accessoires

Si vous avez besoin de commander des pièces de rechange ou des accessoires, nous vous recommandons d'utiliser seulement des pièces FSP® spécifiées par l'usine. Ces pièces conviendront et fonctionneront bien parce qu'elles sont fabriquées avec la même précision que celle utilisée dans la fabrication de chaque nouvel appareil de marque Amana, Admiral, Estate, Inglis, ou Roper de Whirlpool Corporation ou Whirlpool Canada LP. Pour localiser des pièces de rechange FSP® ou des accessoires ou pour obtenir de l'aide dans votre région :

Pour trouver des pièces de rechange FSP®, de l'aide ou des accessoires dans votre région :

Whirlpool Canada LP Centre pour l'eXpérience de la clientèle **800-807-6777** www.whirlpoolappliances.ca

ou contacter votre centre de réparation désigné le plus proche, ou encore consulter les Pages Jaunes.

Nos consultants fournissent l'assistance pour :

- Procédés d'utilisation et d'entretien.
- Vente d'accessoires et de pièces de rechange.
- Les références aux concessionnaires, compagnies de service de réparation et distributeurs de pièces de rechange locaux. Les techniciens de service désignés par Whirlpool sont formés pour remplir la garantie des produits et fournir un service après la garantie, partout au Canada.

Pour plus d'assistance

Vous pouvez nous soumettre toute question ou problème en écrivant à l'adresse ci-dessous :

Centre pour l'eXpérience de la clientèle
Whirlpool Canada LP
Unit 200-6750 Century Ave
Mississauga, Ontario L5N 0B7

Dans votre correspondance, veuillez indiquer un numéro de téléphone où on peut vous joindre dans la journée.