

# Haier

Owner's Manual &  
Installation Instructions

Manuel d'utilisation et  
Instruction d'installation

Manual del propietario y  
Instrucciones de instalación

Washers  
Laveuses  
Lavadoras

QFW150 Series/Séries/Serie

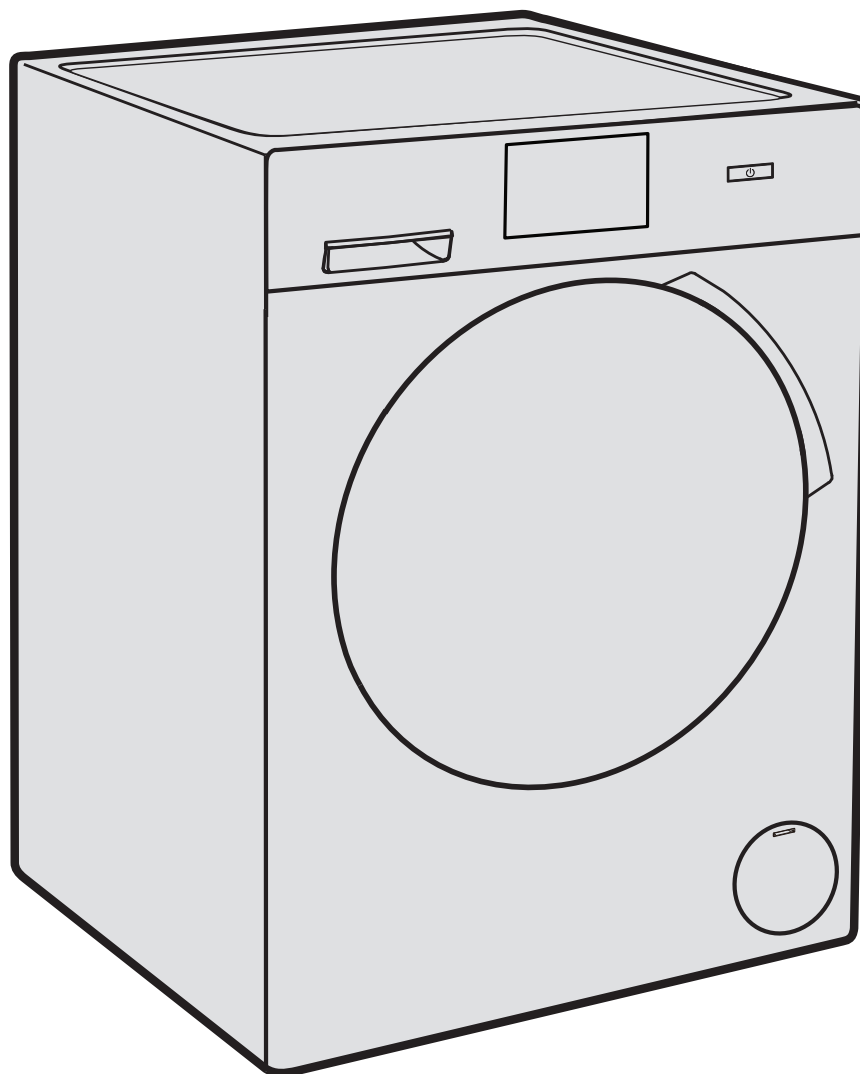

# TABLE OF CONTENTS

**SAFETY INFORMATION** ..... **3**

**USING THE WASHER** ..... **5**

    Getting started ..... 5

    Dispensers ..... 12

    Loading ..... 13

**CARE AND CLEANING** ..... **14**

**INSTALLATION INSTRUCTIONS** ..... **16**

**TROUBLESHOOTING TIPS** ..... **21**

**LIMITED WARRANTY** ..... **27**

**CONSUMER SUPPORT** ..... **28**

## RECORD KEEPING

Thank you for purchasing this Haier Appliances product. This Owner's Manual will help you get the best performance from your new washer.

For future reference, record the model and serial number located on a label inside the door.

Staple your proof of purchase to this manual to aid in obtaining warranty service if needed.

---

Model number

---

Serial number

---

Date of purchase

## SAFETY INFORMATION

# IMPORTANT SAFETY INFORMATION READ ALL INSTRUCTIONS BEFORE USING THE APPLIANCE

### **⚠ WARNING**

To reduce the risk of death, fire, explosion, electric shock, or injury to persons when using your appliance, follow basic precautions, including the following:

- Read all instructions before using the appliance.
- Follow all fabric care instructions and warnings to prevent melting of garments or damage to the appliance.
- **DO NOT** wash or dry articles that have been previously cleaned in, washed in, soaked in or spotted with gasoline, dry-cleaning solvents, or other flammable or explosive substances, as they give off vapors that could ignite or explode.
- **DO NOT** add gasoline, dry-cleaning solvents, or other flammable or explosive substances to the wash water. These substances give off vapors that could ignite or explode.
- Under certain conditions, hydrogen gas may be produced in a hot-water system that has not been used for 2 weeks or more. **HYDROGEN GAS IS EXPLOSIVE.** If the hot water system has not been used for such a period, before using a washing machine, turn on all hot-water faucets and let the water flow from each for several minutes. This will release any accumulated hydrogen gas. As the gas is flammable, **DO NOT** smoke or use an open flame during this time.
- **DO NOT** allow children to play on or in this appliance. Close supervision of children is necessary when this appliance is used near children. Before the washer is removed from service or discarded, remove the door or lid. Failure to follow these instructions may result in death or injury to persons.
- **DO NOT** reach into the appliance if the tub or agitator is moving to prevent accidental entanglement.
- **DO NOT** install or store this appliance where it will be exposed to the weather.
- **DO NOT** tamper with controls, repair or replace any part of this appliance or attempt any servicing unless specifically recommended in the user maintenance instructions or in published user repair instructions that you understand and have the skills to carry out.
- **DO NOT** climb or stand on this unit.
- **DO NOT** operate this appliance if it is damaged, malfunctioning, partially disassembled, or has missing or broken parts including a damaged cord or plug.
- Unplug the appliance or turn off the circuit breaker before servicing. Pressing the **Power** button (⏻) **DOES NOT** disconnect power.
- See "ELECTRICAL REQUIREMENTS" located in the Installation Instructions for grounding instructions.

## READ AND SAVE THESE INSTRUCTIONS

## SAFETY INFORMATION

### IMPORTANT SAFETY INFORMATION READ ALL INSTRUCTIONS BEFORE USING THE APPLIANCE

#### PROPER INSTALLATION

This washer must be properly installed and located in accordance with the Installation Instructions before it is used.

- Ensure that the hot water hose is connected to the "H" valve and the cold water hose is connected to the "C" valve.
- Install or store where it will not be exposed to temperatures below freezing or exposed to the weather, which could cause permanent damage and invalidate the warranty.
- Properly ground washer to conform with all governing codes and ordinances. Follow details in the Installation Instructions.
- Ensure washer is properly leveled and washer legs are adjusted such that unit is stable.
- Optional drain hose extension recommended for discharging heights from 60" - 96".
- Haier Appliances strongly recommends the use of factory specified parts. A list of factory hoses available for purchase are listed. These hoses are manufactured and tested to meet Haier Appliances specifications.
- Haier Appliances strongly recommends the use of new water supply hoses. Hoses degrade over time and need to be replaced every 5 years to reduce the risk of hose failures and water damage.

#### WHEN NOT IN USE

- Turn off water faucets to minimize leakage if a break or rupture should occur. Check the condition of the fill hoses; Haier Appliances recommends changing the hoses every 5 years.

#### PARTS AND ACCESSORIES

Visit our website at [haierappliances.com/parts](http://haierappliances.com/parts) or in Canada visit [haiercanada.ca/parts](http://haiercanada.ca/parts).

Part Number	Accessory
PM14X10002	4 ft rubber water supply hoses
<b>Or</b>	
PM14X10005	4 ft braided water supply hoses
WX10X10011	Tide® Washing Machine Cleaner*
PM7X1	Washer Floor Tray

\*Tide® is a registered trademark of Procter & Gamble

## READ AND SAVE THESE INSTRUCTIONS

# USING THE WASHER

Features and appearance will vary throughout this manual

## ⚠ WARNING

To reduce the risk of fire, electric shock, or injury to persons, read the IMPORTANT SAFETY INFORMATION before operating this appliance.

### Step 1

(Appearance will vary)



- Add fabric softener to the fabric softener dispenser; see page 10.
- Add the manufacturer's recommended amount of detergent. Haier Appliances recommends the use of High Efficiency detergents such as in your energy efficient washer. Place detergent pods in the bottom of the wash basket before adding clothes.

### Step 2



- Loosely add items. Overloading may negatively impact wash performance. See page 11 for suggested loading examples.
  - Close door.
- NOTE:** Washer will not start with door open.

### Step 3



- If the screen is dark, press and hold the Power button for 2 seconds to "wake up" the display.

### Step 4



- Select a wash cycle. (Defaults are set for each wash cycle. These default settings can be changed. See Control settings for more information.)
- Press the Start button for 1 second.

\*Instructions can also be found by touching the document (📄) icon, on the cycle selection screen, in the top right corner.

## Controls

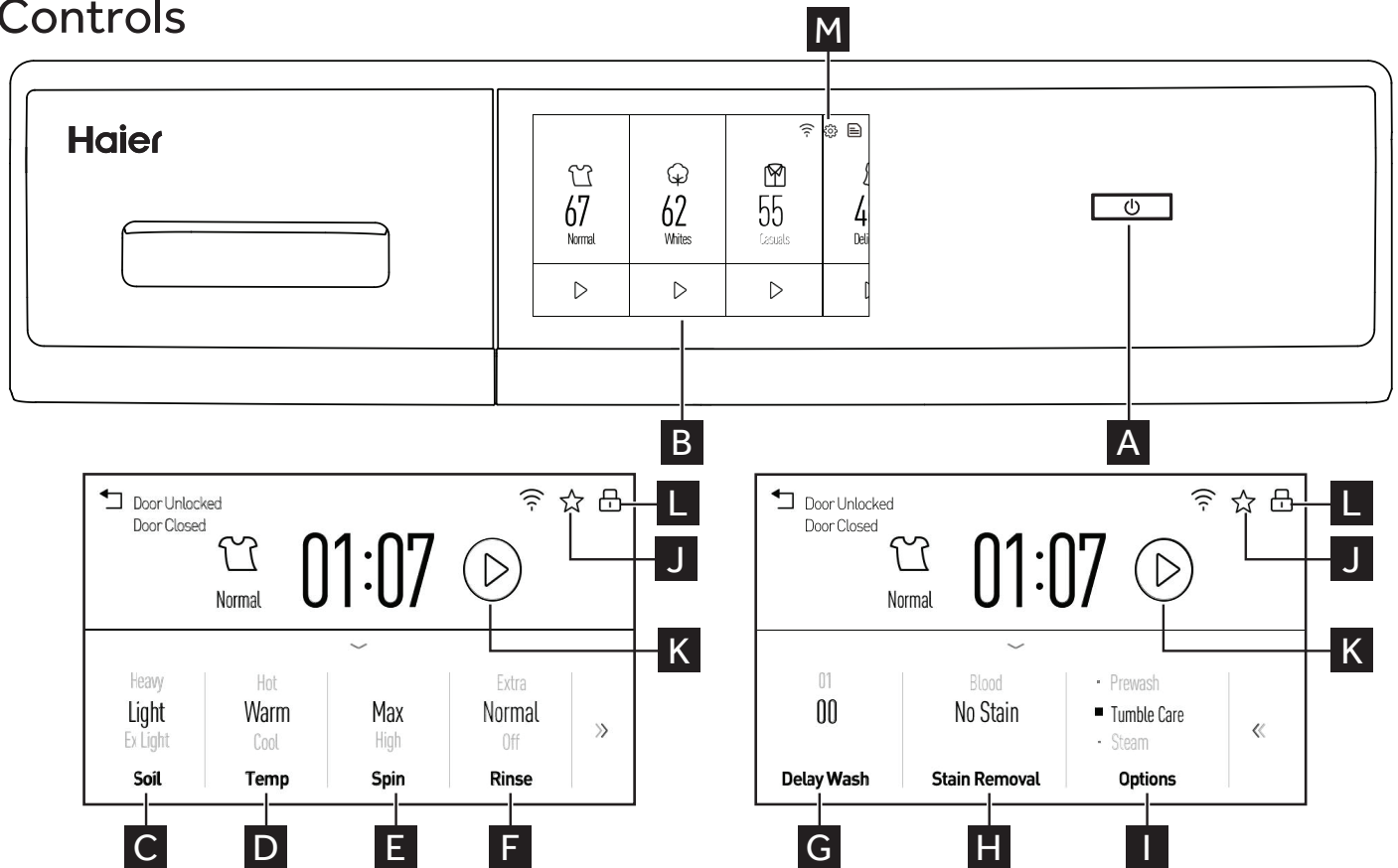

# USING THE WASHER

## Display and Status Lights

The display shows the approximate time remaining until the end of the cycle.

**In addition, this display will show the washer status:**

Status	Fill >> Wash >> Rinse >> Spin
Lock Symbol	Controls lock feature.
Estimated Time Remaining	Display shows the estimated time remaining until set cycle is completed.
Ext Tumble	Indicates the Extended Tumble feature is set.
Delay Wash	Indicates Delay Wash set time is selected.
PreWash	Indicates PreWash is selected.
Steam	Indicates Steam is selected.
Tumble Care	Indicates Tumble Care is selected.

**NOTE:** If an out-of-balance condition is detected by the washer, an **Out-of-Balance indicator** will appear and blink during the remaining portion of the cycle. It will stay illuminated for a short time after cycle completion. When this occurs, the washer is taking actions to correct the out-of-balance condition and complete the cycle normally. In some cases, the washer may not be able to balance the load and spin up to full speed. If you notice the load is more wet than usual at the end of the cycle, redistribute the load evenly in the wash tub and run a **Drain+Spin** cycle.

### A Power

Press and hold for 2 seconds to "wake up" the display. If the display is active, press and hold for 2 seconds to turn the washer off.

**NOTE:** Pressing **Power** does not disconnect the appliance from the power supply.

### B Wash Cycles

The wash cycles are optimized for specific types of wash loads. The chart below will help you match the wash setting with the loads. The Gentle Wash™ lifters lightly tumble the clothes into the water and detergent solution to clean the load.

Items to Wash	Cycle	Soil Level	Wash Temp	Spin Selection	Options Available	Cycle Details
Cycle for normal, regular, or typical use for washing up to a full load of normally soiled cotton clothing.	Normal	Ex. Heavy Heavy <b>Normal</b> Light Ex. Light	Extra Hot Hot <b>Warm</b> Cool Cold	<b>Max</b> High Medium No Spin	Extra Rinse Delay Wash Stain Removal Guide Time Saver Prewash Tumble Care Steam My Cycle	Cycle for normal, regular, or typical use for washing up to a full load of normally soiled cotton clothing. Choose the Heavy or Extra Heavy soil level selection and Warm or Hot water temperature selection as appropriate for your clothes load for a higher degree of cleaning.
Whites and household linens.	Whites	Ex. Heavy Heavy <b>Normal</b> Light Ex. Light	Extra Hot Hot <b>Warm</b> Cool Cold	<b>Max</b> <b>High</b> <b>Medium</b> <b>Low</b> <b>No Spin</b>	Extra Rinse Delay Wash Stain Removal Guide Time Saver Prewash Tumble Care Steam My Cycle	Cycle tailored to clean and brighten your whites.
Casual clothes, lightly soiled office wear.	Casuals	Ex. Heavy Heavy <b>Normal</b> Light Ex. Light	Extra Hot Hot <b>Warm</b> Cool Cold	<b>Max</b> <b>High</b> Medium Low No Spin	Extra Rinse Delay Wash Stain Removal Guide Time Saver Prewash Tumble Care Steam My Cycle	Wash cycle tailored to care for casual clothes and office wear items.

# USING THE WASHER

## B Wash Cycles - Continued

Items to Wash	Cycle	Soil Level	Wash Temp	Spin Selection	Options Available	Cycle Details
Lingerie and special care fabrics with light soil.	Delicates	Ex. Heavy Heavy <b>Normal</b> Light Ex. Light	Warm Cool <b>Cold</b>	High <b>Medium</b> Low No Spin	Extra Rinse Delay Wash Stain Removal Guide Time Saver Prewash Tumble Care  My Cycle	For lightly soiled items labeled handwashable. Provides gentle tumbling and soak during wash and rinse.
Sturdy fabrics with heavy to medium soil.	Bulky Items	Ex. Heavy <b>Heavy</b> Normal Light Ex. Light	Extra Hot Hot <b>Warm</b> Cool Cold	<b>Max</b> High Medium Low No Spin	Extra Rinse Delay Wash Stain Removal Guide Time Saver Prewash Tumble Care Steam My Cycle	Incorporates multi-step wash and soak periods combined with extended wash periods to effectively clean heavily to medium soiled sturdy fabrics.
Towels, sheets, pillowcases and dish rags.	Towels & Sheets	Ex. Heavy Heavy <b>Normal</b> Light Ex. Light	Extra Hot Hot <b>Warm</b> Cool Cold	<b>Max</b> High Medium Low No Spin	Extra Rinse Delay Wash Stain Removal Guide Time Saver Prewash Tumble Care Steam My Cycle	Cycle designed for washing towels, sheets, pillowcases and dish rags. It is recommended that towels and sheets be washed separately for best care and washing performance.
Denim or heavy cotton canvas textiles.	Jeans	Ex. Heavy Heavy <b>Normal</b> Light Ex. Light	Extra Hot Hot <b>Warm</b> Cool Cold	<b>Max</b> High Medium Low No Spin	Extra Rinse Delay Wash Stain Removal Guide Time Saver Prewash Tumble Care Steam My Cycle	Incorporates multi-step wash and soak periods intended to optimize the washing of denim and heavy canvas textiles.
Medium to lightly soiled athletic wear items of technical or synthetic fabrics.	Active Wear	Ex. Heavy <b>Heavy</b> Normal Light Ex. Light	Extra Hot Hot Warm <b>Cool</b> Cold	Max <b>High</b> Medium Low No Spin	Extra Rinse Delay Wash Stain Removal Guide Time Saver Prewash Tumble Care Steam My Cycle	Cycle designed for care of medium to lightly soiled active wear, athletic wear and technical fabrics.
Garments with wool contents.	Wool	Ex. Heavy <b>Heavy</b> Normal Light Ex. Light	<b>Cool</b> Cold	<b>Low</b> No Spin	Extra Rinse Delay Wash  Time Saver Prewash Tumble Care  My Cycle	Balances cool water with gentle agitation and low spin intended to safely clean wool fabrics.
Small garments such children's clothes.	Baby Care	Ex. Heavy Heavy Normal <b>Light</b> Ex. Light	Extra Hot Hot <b>Warm</b> Cool Cold	Max High <b>Medium</b> Low No Spin	Extra Rinse Delay Wash Stain Removal Guide Time Saver Prewash Tumble Care Steam My Cycle	Wash cycle tailored to care for children's clothes and other small items.

# USING THE WASHER

## B Wash Cycles - Continued

Items to Wash	Cycle	Soil Level	Wash Temp	Spin Selection	Options Available	Cycle Details
Small loads of lightly soiled items that are needed in a hurry.	Quick Wash	Ex. Heavy Heavy Normal Light <b>Ex. Light</b>	Hot <b>Warm</b> Cool Cold	<b>Max</b> High Medium Low No Spin	Extra Rinse Delay Wash Stain Removal Guide  Prewash Tumble Care  My Cycle	For cleaning lightly soiled loads in the fastest time possible. Cycle time is approximately 33 minutes, depending on selected options.
Heavily soiled colorfast items with the need for sanitization.	Sanitize	Ex. Heavy Heavy <b>Normal</b> Light Ex. Light	<b>Extra Hot</b>	<b>Max</b> High Medium Low No Spin	Extra Rinse Delay Wash Stain Removal Guide  Prewash Tumble Care  My Cycle	Use this cycle to eliminate 99.9% of bacteria from fabrics. Cycle uses an increased water temperature and a longer wash cycle to provide the sanitization benefit. A longer rinse is incorporated to remove contaminants. For best results, select the Extra Heavy soil selection if available. See NOTE.
For removing common allergens such as dust mites and pet dander.	Allergen	Ex. Heavy Heavy <b>Normal</b> Light Ex. Light	<b>Extra Hot</b>	<b>Max</b> High Medium Low No Spin	Extra Rinse Delay Wash Stain Removal Guide  Prewash Tumble Care  My Cycle	Use this cycle to remove common allergens such as dust mites and pet dander. Cycle uses an increased water temperature and a longer wash cycle to provide the sanitization benefit. A pump purge and longer rinse is incorporated to remove contaminants. For best results, select the Extra Heavy soil selection if available. Extra Rinse is on by default. See NOTE below for more details. Extra Rinse is Default
For items that need only to be rinsed, use this cycle.	Rinse+Spin			<b>Max</b> High Medium Low No Spin	Extra Rinse Delay Wash	To quickly rinse and spin out any items at any time. Utilizes a high speed spin to extract water from wet items.
For items that need to quickly drain and spin out, use this cycle.	Drain+Spin			<b>Max</b> High Medium Low No Spin	Delay Wash	To quickly drain and spin out any items at any time. Utilizes a high speed spin to extract water from wet items.
Cleaning the tub of residue and odor. No clothes to be washed using this cycle.	Tub Clean					Recommended use of at least once per month to clean the basket of residue and odor. Never load laundry when using this cycle; laundry may become damaged. Cycle incorporates a hot extended wash, intense agitation action and a flush out of the pump.

**NOTE:** The **Sanitize** and **Allergen** cycle water temperatures CANNOT be changed. The **Sanitize** cycle is certified by NSF International, an independent third party testing and certification organization.

The **Sanitize** certification verifies that the cycle reduced 99.9% of bacteria typically found in residential laundry and that no significant contamination is transferred to subsequent washer loads. Only the **Sanitize** cycle has been designed to meet the requirements of NSF Protocol P172 for sanitizing effectiveness.



NSF Protocol P172  
Sanitization Performance of Residential and Commercial, Family-Sized Clothes Washers

The **Allergen** certification verifies that the cycle reduced at least 95% of dust mites and pet dander. Only the **Allergen** cycle has been designed to meet the requirements of NSF Protocol P351 for allergen reducing effectiveness.



NSF Protocol P351  
Allergen Reduction Performance of Residential and Commercial, Family-Sized Clothes Washers



# USING THE WASHER

C

## Soil

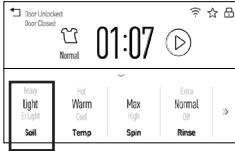

Changing the **Soil** level increases or decreases the wash time to remove different amounts of soil. To change the **Soil** level, locate the **Soil** level section on the cycle screen and scroll up or down until you have reached the desired setting. You can choose between Extra Light, Light, Normal, Heavy or Extra Heavy soil.

D

## Temp



Adjust to select the proper water temperature for the wash cycle. The rinse water is always cold to help reduce energy usage and reduce setting of stains and wrinkles.

Follow the fabric manufacturer's care label when selecting the wash temperature.

To change the wash temperature, locate the **Temp** section on the cycle screen and scroll up or down until you have reached the desired setting. You can choose between Cold, Cool, Warm, Hot or Extra Hot.

E

## Spin



Changing the **Spin** setting changes the final spin speed of the cycles. Always follow the garment manufacturer's care label when changing the **Spin** setting.

To change the **Spin** setting, locate the spin section on the cycle screen and scroll up or down until you have reached the desired setting. You can choose between No Spin, Low, Medium, High or Max.

Higher spin speeds remove more water from the clothes and will help reduce dry time, but may also increase the possibility of setting wrinkles on some fabrics.

F

## Rinse



Changing **Rinse** will change the number of rinses the cycle will use. To change the rinse option, locate the Rinse section on the cycle screen and scroll up or down until you have reached the desired setting. You can choose between Normal, Extra and no rinse.

G

## Delay Wash



Use to delay the start of your washer.

1. Choose your wash cycle and any options.
2. In the **Delay Wash** section you can change the delay time in 1 hour increments up to 24 hours.
3. Press and hold the **Start** button for 1 seconds to start the countdown. The selected delay time will not be shown on the screen. Only the estimated cycle time will be visible. Once the delayed time period has been completed, the selected dry cycle will start.

**NOTE:** If the door is opened while the dryer is in **Delay Wash**, the countdown time will not restart unless the door is closed and **Start** button has been pressed again.

# USING THE WASHER

H

## Stain Removal Guide



The Stain Removal guide is pre-programmed with the ideal wash and rinse settings to tackle five common stains. To use this feature, select the desired wash cycle and locate the **Stain Removal** guide menu and select the stain you want to remove. Next, press **Start**.

For some stains, a prewash will be selected automatically. If desired, add detergent or wash additive to the prewash dispenser. **Add Steam** cannot be selected along with this feature.

I

## Options

### Prewash

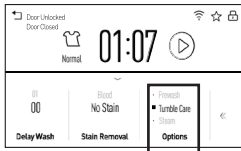

Prewash is an extra wash before the main wash. Use it for heavily soiled clothes or for clothes with a care label that recommends prewashing before washing. Be sure to add liquid or powder high efficiency detergent, or the proper wash additive to the prewash dispenser. The **PreWash** feature will fill the washer with water (adding the prewash detergent), tumble the clothes, drain and spin. Then the washer will run the selected wash cycle. **NOTE:** The **PreWash** is not selected automatically and must be selected before starting the cycle.

### Tumble Care

Freshly tumbles your garments periodically for up to 8 hours after the wash cycle is complete to lessen the setting of wrinkles and creases when you are not able to move clothing to the dryer right away. At the end of the cycle, the display will scroll "END" and after ten minutes the **Tumble Care** will begin. It can be stopped at any time by pressing the **Power** button. **NOTE:** The **Tumble Care** option cannot be added to the **My Cycle** feature.

### Steam

Steam adds steam into the washer early in the cycle to assist with loosening stains on the **Whites, Normal, Casuals, Bulky Items, Jeans, Towels/Sheets, Active Wear, and Baby Care** cycles.

To use:

1. Turn power **ON** and select a wash cycle which has **Steam** as an option.
2. Select the **Add Steam** button to activate steam.
3. Press the **Start/Pause** button.

### Time Saver

Use this option to reduce the overall wash cycle by at least 20% without sacrificing wash performance. This feature is available on all cycles except **Quick Wash, Sanitize, Allergen, Rinse+Spin, Drain+Spin, and TubClean**. This option will modify the wash cycle, slightly raising the wash temperature and using more water to deliver equal wash performance as the basic cycle. All other features, such as **Prewash, Extra Rinse, Add Steam, etc.** can be used with **Time Saver** but may adjust the total wash time.

To use:

1. Turn power on and select a wash cycle which has **Time Saver** as an option.
2. Make any adjustments to **Soil, Temp** and **Spin** as desired.
3. Press the **Time Saver** button to reduce the overall wash time.
4. Press the **Start/Pause** button.

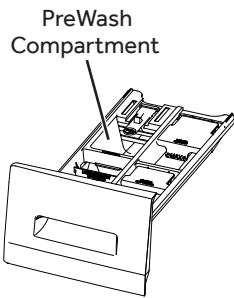

J

## My Cycle

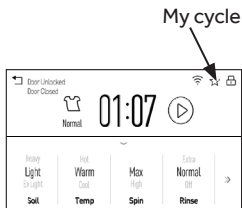

Set up your favorite combination of settings for each cycle and save them here for one touch recall. These custom settings can be set while a cycle is in progress.

**NOTE:** You can store 1 **My Cycle** combination of settings for each cycle.

### To store a My Cycle combination of settings:

1. Select your washing cycle.
2. Change **Temp** and **Level** settings to fit your needs.
3. Select any washing options you want.
4. Press and hold the ☆ for 3 seconds to store your selection. A beep will sound and the button will light up.

### To recall your stored My Cycle combination:

Select the cycle and press the ☆ before washing a load.

### To change your stored My Cycle combination:

Repeat steps 1–4.

# USING THE WASHER

K

Start cycle



## Start/Pause

Press to start a wash cycle. If the washer is running, pressing it once will pause the washer and unlock the door. This function can be used to add garments during a cycle. Press again to restart the wash cycle.

### Start

Press and hold for 1 second to start or restart a cycle.

### Pause

If the washer is running, press and hold for 1 second to pause the cycle. This function can be used to add garments during a cycle.

**NOTE:** If the washer is paused and the cycle is not restarted within 15 minutes, the current wash cycle will be cancelled.

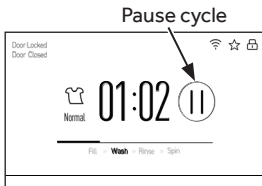

L

Lock Symbol



## Lock

You can lock the controls to prevent any selections from being made. Or you can lock or unlock the controls after you have started a cycle.

Children cannot accidentally start the washer by touching pads with this option selected.

**To lock the washer controls,** press and hold the lock symbol (🔒) in the top right corner for 3 seconds and a lock screen will appear asking if you want to lock the machine.

To unlock the washer controls, press and hold the unlock symbol (🔓) for 3 seconds and the lock screen will disappear.

**NOTE:** The **Power** button can still be used when the machine is locked.

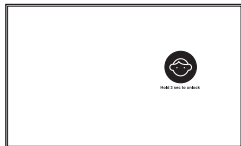
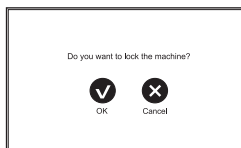

M

Gear Symbol

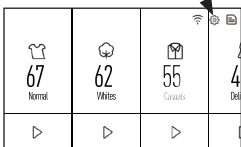

## Settings

Select the gear symbol (⚙️) in the top right corner to enter the **Settings** screen.

### Volume

When the control panel is powered on, the washer will beep at the end of the cycle and every time you press a button on the control panel.

Use the options pad to select either High, Med, Low, or Off.

**NOTE:** The selected volume is for both end of cycle and pad sounds.

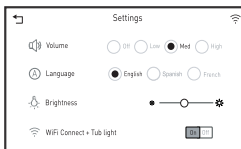

### Language

Use the **Option** pad to select either English, Spanish, or French.

### Brightness

To change the brightness of the screen, use the brightness slider to change from darker to brighter.

### WiFi Connect + Tub Light

Use the **WiFi Connect + Tub Light** toggle button to turn this feature on or off. Toggling this feature on will enable the WiFi Connect function and enable the usage of the tub light when the door is opened & closed. Follow the directions on the Wifi Connect screen using the information provided to connect with the GEA Laundry App. Toggling this feature off will disable the Wifi Connect function and disable the tub light.

**NOTE:** When the washer to set up with the GEA Laundry App, new software may be available to install. After approving the installation of the new software through the GEA Laundry App, the washer tub light will flash on and off during the software installation. The washer tub light will stop flashing and turn off after the software is done installing.

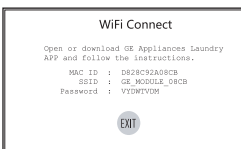

# USING THE WASHER

## Dispenser Drawer

Slowly open the dispenser drawer by pulling it out until it stops.

After adding laundry products, slowly close the dispenser drawer. Closing the drawer too quickly could result in early dispensing of the fabric softener or detergent.

You may see water in the fabric softener compartment at the end of the cycle. This is a result of the flushing/siphoning action and is part of the normal operation of the washer.

Use only HE  
High-Efficiency  
detergent

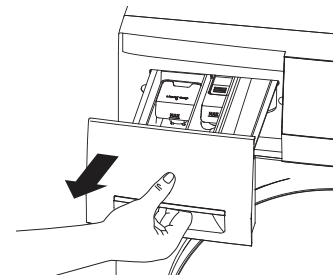

## Detergent Compartment

- Only use high-efficiency detergent in this washer. Use the detergent manufacturer's recommended amount. **DO NOT fill above the MAX line.**
- Detergent is flushed from the dispenser at the beginning of the wash cycle. Either powdered or liquid high-efficiency detergent can be used.
- Detergent usage may need to be adjusted for water temperature, water hardness, size and soil level of the load. Avoid using too much detergent in your washer since it can lead to oversudsing and detergent residue being left on the clothes.

### Divider Drawer System (on some models)

The detergent compartment is in the **front left** of the dispenser drawer.

#### • Powder Detergent –

Lock the detergent card flat into its top position in the compartment. Make sure the card is locked, then pour the suggested amount of powder detergent into the detergent dispenser.

#### • Liquid Detergent –

Lock the detergent card vertically into its center position in the compartment. Make sure the card is locked, then pour the suggested amount of liquid detergent into the detergent dispenser.

PreWash Compartment (no cup) – Use for Liquid and Powder Detergent

Lock in HORIZONTAL position for Powder Detergent and VERTICAL position for Liquid Detergent

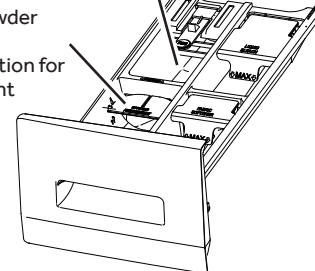

## Bleach Compartment

If desired, measure out the recommended amount of liquid bleach, not to exceed 1/3 cup (80 ml), and pour into the right compartment labeled "LIQUID BLEACH".

Do not exceed the maximum fill line. Overfilling can cause early dispensing of the bleach which could result in damaged clothes.

**NOTE:** Do not use powdered bleach in the dispenser.

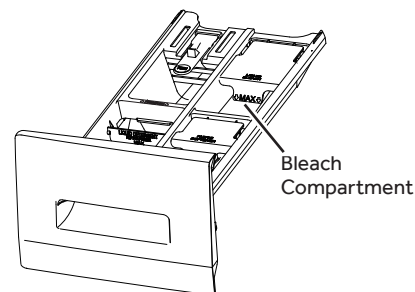

## Fabric Softener Compartment

If desired, pour the recommended amount of liquid fabric softener into the compartment labeled "Fabric Softener."

Use only liquid fabric softener in the dispenser.

Dilute with water to the maximum fill line.

Do not exceed the maximum fill line. Overfilling can cause early dispensing of the fabric softener, which could stain clothes.

**NOTE:** Do not pour fabric softener directly on the wash load.

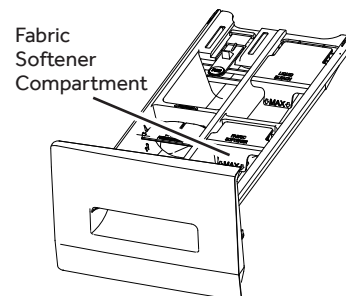

# LOADING

Always follow fabric manufacturer’s care label when laundering.

## Sorting Wash Loads

Sort by color (whites, lights, colors), soil level, fabric type (sturdy cottons, easy care, delicates) and whether the fabric produces lint (terry cloth, chenille) or collects lint (velveteen, corduroy). Wash lint producers such as cotton towels and socks separate from lint collectors including synthetic garments and dress pants.

**⚠ WARNING  - Fire Hazard**

**DO NOT** wash fabrics soiled with flammable liquids or cleaning solvents.  
No washer can completely remove oil.

**DO NOT** wash or dry anything that has been soaked in or spotted with any type of oil (including cooking oils).

**DO NOT** reach into the washer until all moving parts have stopped.  
Doing so can result in death, explosion, fire or amputation.

## Loading the Washer

The wash drum may be fully loaded with loosely added items.

To add items after the washer has started, press **Pause** and wait until the door is unlatched. The washer may take up to 30 seconds to unlock the door after pressing **Pause**, depending on the machine conditions. Do not try to force open the door when it is locked. After the door unlocks, open gently. Add items, close the door and press **Start** to restart.

The wash drum may be fully loaded with loosely added items.

## Loading Examples

WORKWEAR	LINENS	MIXED LOAD	DELICATES*	QUICK WASH (2-3 GARMENTS)
3 Jeans 3 Work Wear Shirts 2 Work Wear Pants	1 Bath Sheet 6 Bath Towels/ 8 Washcloths 4 Hand Towels/ 1 Terrycloth Bath Mat <b>OR</b> 1 Flat Queen-Sized Sheet 1 Fitted Queen-Sized Sheet 2 Pillowcases	2 Pillowcases 1 Hand Towel 1 Flat Sheet/ 1 Fitted Sheet 2 Bath Towels/ 2 Washcloths <b>OR</b> 4 Shirts (Men’s or Women’s) 3 Pair Pants (Khakis or Twills) 3 T-shirts 4 Pairs of Boxers 2 Pairs of Shorts <b>OR</b> 4 T-shirts 2 Pairs of Sweatpants 2 Sweatshirts 1 Hoodie 5 Pairs of Socks	4 Bras 4 panties 2 Slips 1 Camisole 3 Nightgowns *Using a nylon mesh bag for small items is recommended.	2 Casual Wear Work Shirts 1 Pair Casual Wear Work Pants <b>OR</b> 3 Soccer Uniforms

# CARE AND CLEANING

## Water Supply Hoses

Hoses connecting washer to faucet should be replaced every 5 years.

## Exterior

Immediately wipe off any spills. Wipe with damp cloth. Wipe or dust spills or washing compounds with a damp cloth. Washer control panel and finishes may be damaged by some laundry pretreatment and stain remover products. Apply these products away from the washer. The fabric may then be washed and dried normally. Damage to your washer caused by these products is not covered by your warranty. Do not hit surface with sharp objects.

## Interior

Dry around the washer door opening, flexible gasket (including attached hoses) and door glass. These areas should always be clean to ensure a watertight seal.

It is recommended to rinse the washer at least once per month with 1 cup of bleach (or other commercially available product manufactured for this purpose, such as Tide® Washing Machine Cleaner) poured directly into the basket without clothes and using the **Tub Clean** Cycle.

## Pump Filter

**Clean EVERY MONTH to remove any items that may have been caught in the filter or housing.**

Due to the nature of the front-load washer, it is sometimes possible for small articles to pass to the pump. The washer has a filter to capture lost items so they are not dumped to the drain. To retrieve lost items, clean out the pump filter.

- 1 Open the door on the bottom right of the front of the unit.
- 2 Twist the small white cap counterclockwise a quarter turn and unhook the small rubber hose. Pull the hose out of the hole and remove the white drain hose plug above a small pan to capture any water that may drain. Drain the excess water. Replace.
- 3 Unscrew the pump filter. Rinse off any debris. Replace.
- 4 Close the access door.

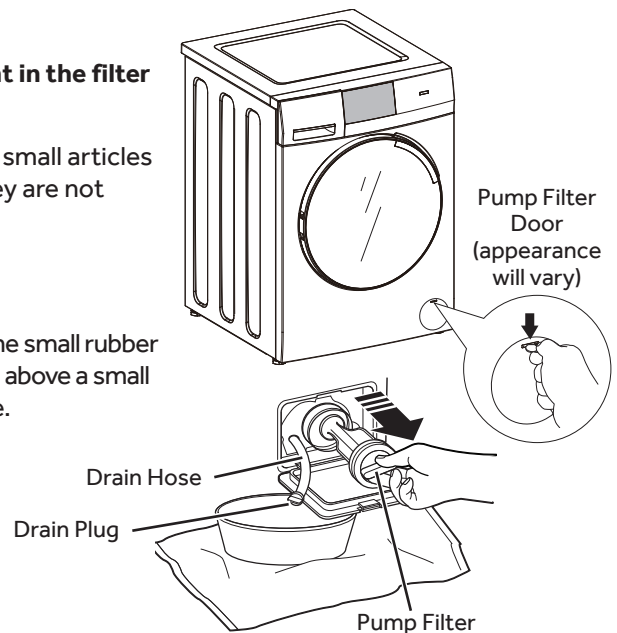

## Door Gasket

Open the washer door. Using both hands, press down the door gasket. Remove any foreign objects if found trapped inside the gasket. Make sure there is nothing blocking the holes behind the gasket.

While holding down the door gasket, inspect the interior of the gasket by pulling it down with your fingers. Remove any foreign objects if found trapped inside this gasket. Make sure there is nothing blocking the holes behind the gasket.

When you are finished cleaning the door gasket, remove your hands and the gaskets will return to the operating position.

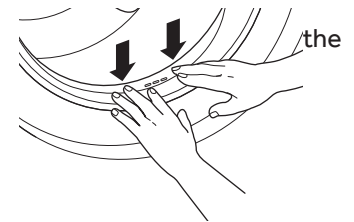

# CARE AND CLEANING

## Dispenser Drawer Area

Detergent and fabric softener may build up in the dispenser drawer. Residue should be removed once or twice a month.

- Remove the drawer by first pulling it out until it stops. Then reach back into the rear center of the drawer cavity and press down firmly on the lock tab, pulling out the drawer.

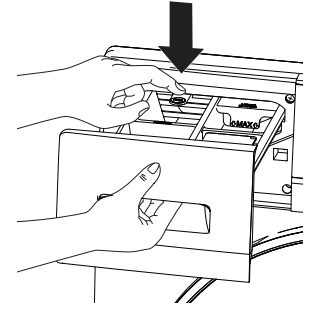

- Remove all cups and inserts from the dispenser drawer. Rinse the inserts, cups and drawer with hot water to remove traces of accumulated laundry products.

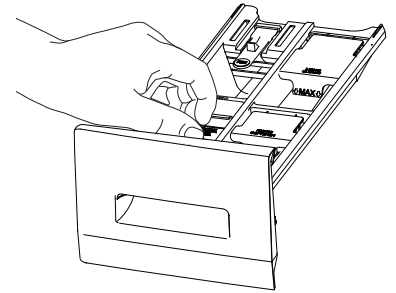

- To clean the drawer opening, use a small brush to clean the recess. Remove all residue from the upper and lower parts of the recess.
- Return inserts to the proper compartments. Replace the dispenser drawer.
- To reduce buildup in the Dispenser Drawer area:

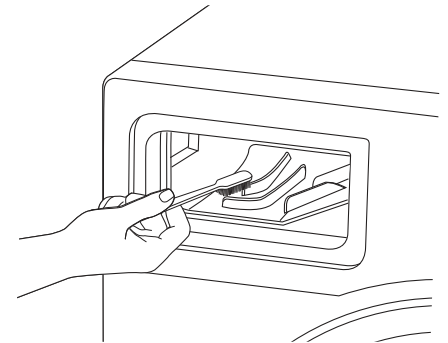

Use only HE  
High-Efficiency  
detergent.



## Moving and Storage

Ask the service technician to remove water from drain pump and hoses. Do not store the washer where it will be exposed to the weather. When moving the washer, the tub should be kept stationary by using the shipping bolts removed during installation. See Installation Instructions in this manual. If these parts are not available, visit our website at [haierappliances.com/parts](http://haierappliances.com/parts) or in Canada visit [haiercanada.ca/parts](http://haiercanada.ca/parts).

## Long Vacations

Be sure water supply is shut off at faucets. Drain all water from hoses and water filter pump area if weather will be below freezing.

# INSTALLATION INSTRUCTIONS

# WASHER



If you have questions, visit our website at [haierappliances.com](http://haierappliances.com)  
or in Canada visit [haiercanada.ca](http://haiercanada.ca).

## BEFORE YOU BEGIN

Read these instructions completely and carefully.

- **IMPORTANT** – Save these instructions for local inspector's use.
- **IMPORTANT** – Observe all governing codes and ordinances.
- **Note to Installer** – Be sure to leave these instructions with the Consumer.
- **Note to Consumer** – Keep these instructions for future reference.
- **Skill level** – Installation of this appliance requires basic mechanical and electrical skills.
- **Completion time** – 1-3 hours
- Proper installation is the responsibility of the installer.
- Product failure due to improper installation is not covered under the Warranty.

## TOOLS REQUIRED FOR WASHER INSTALLATION

- Level 
- Wrench (provided) 
- Channel-lock adjustable pliers 

## PARTS SUPPLIED

- Water Hoses (2)  
(Flat washers pre-installed)
- Drain Hose Guide

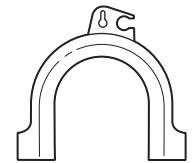
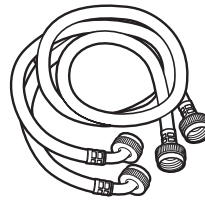

## LOCATION OF YOUR WASHER

### DO NOT Install the Washer:

1. In an area exposed to dripping water or outside weather conditions. The ambient temperature should never be below 60°F (15.6°C) for proper washer operation.
2. In an area where it will come in contact with curtains or drapes.
3. On carpet. The floor **MUST** be a hard surface with a maximum slope of 1/2" per foot (1.27 cm per 30 cm). To make sure the washer does not vibrate or move, you may have to reinforce the floor.

**NOTE:** If floor is in poor condition, use 3/4" impregnated plywood sheet solidly attached to existing floor covering.

### IMPORTANT:

#### Minimum Installation Clearances

- When installed in alcove: Sides/Rear = 0" and Top = 1"
- When installed in closet: Sides/Rear = 0" and Top/Front = 1" (2.54 cm)
- Consideration must be given to provide adequate clearance for installation and service.
- Closet doors must be louvered or otherwise ventilated and have at least 60 square inches (387.1 cm<sup>2</sup>) of open area. If the closet contains both a washer and a dryer, doors must contain a minimum of 120 square inches (774.2 cm<sup>2</sup>) of open area.

## MOBILE HOME INSTALLATION:

Installation must conform to Standard for Mobile Homes, ANSI A119.1 and National Mobile Home Construction and Safety Standards Act of 1974 (PL93-383).



# INSTALLATION INSTRUCTIONS

## CONNECTION DIMENSIONS

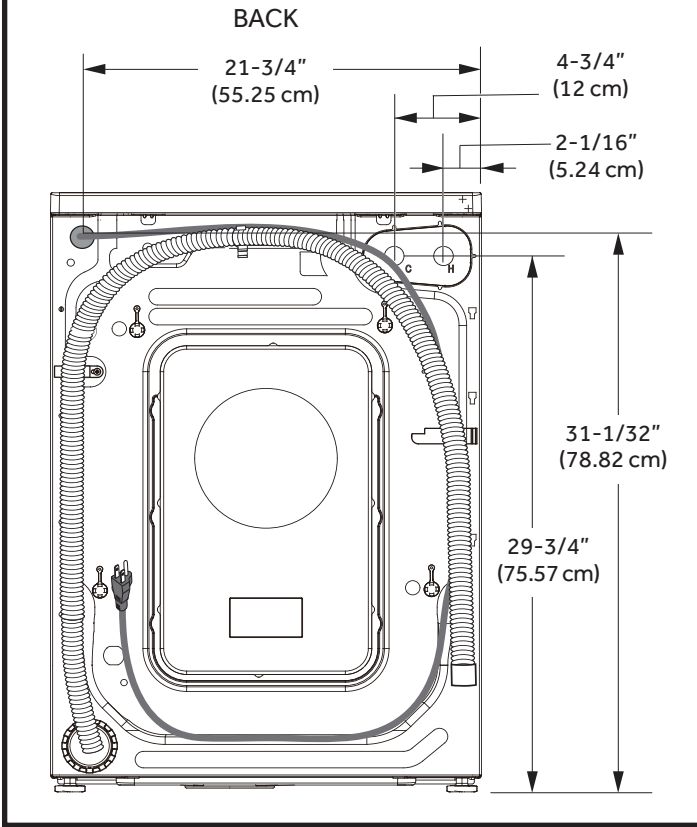

## ROUGH-IN DIMENSIONS

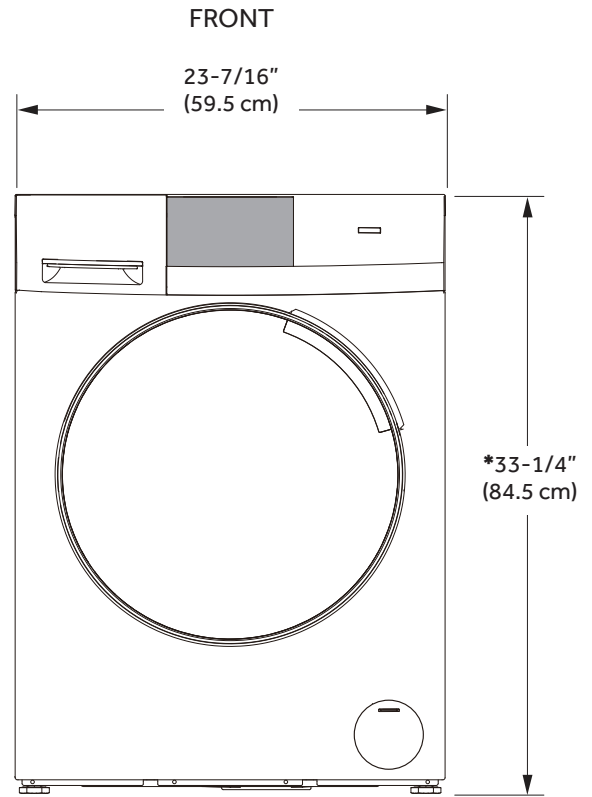

## SIDE

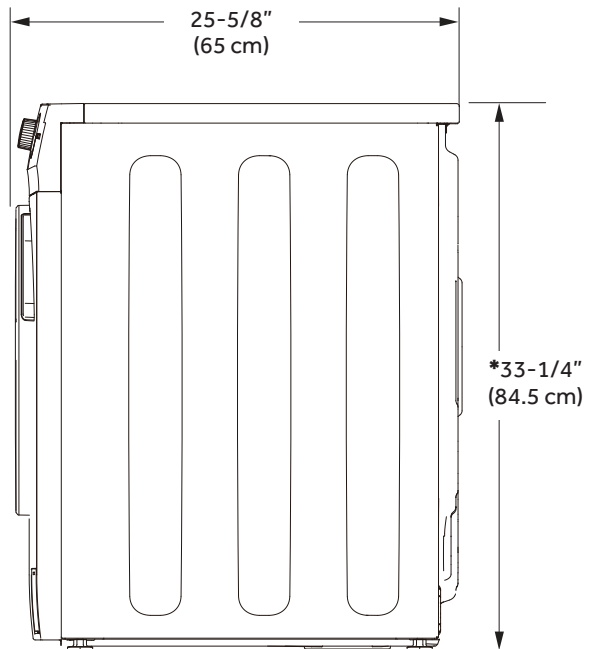

### \*NOTE:

Washer leveling legs retracted = 33-1/4" (84.5 cm)

Washer leveling legs extended = 33-3/4" (85.5 cm)

Stacked = 66-1/2" (169.0 cm)

# INSTALLATION INSTRUCTIONS

## UNPACKING THE WASHER

**▲ WARNING** Recycle or destroy the carton and plastic bags after the washer is unpacked. Make materials inaccessible to children. Children might use them for play. Cartons covered with rugs, bedspreads or plastic sheets can become airtight chambers causing suffocation.

1. Cut and remove all packaging straps.
2. While it is in the carton, carefully lay the washer on its side. **DO NOT** lay the washer on its front or back.
3. Turn down the bottom flaps. Remove all base packaging including the styrofoam base.
4. Carefully return the washer to an upright position and remove the carton by lifting it upward.
5. Carefully move the washer to within 4 feet (122 cm) of the final location.
6. Remove the following from the back side of the washer:
  - 4 bolts
  - 4 plastic spacers (including rubber grommets)

**NOTE:** Do NOT remove the screw or clip holding the hose.

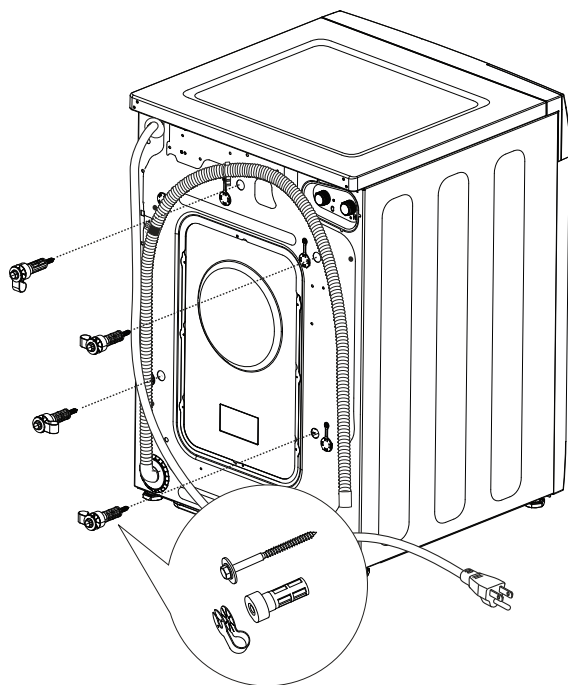

## UNPACKING THE WASHER (cont.)

7. Insert shipping bolt hole covers into shipping bolt holes.

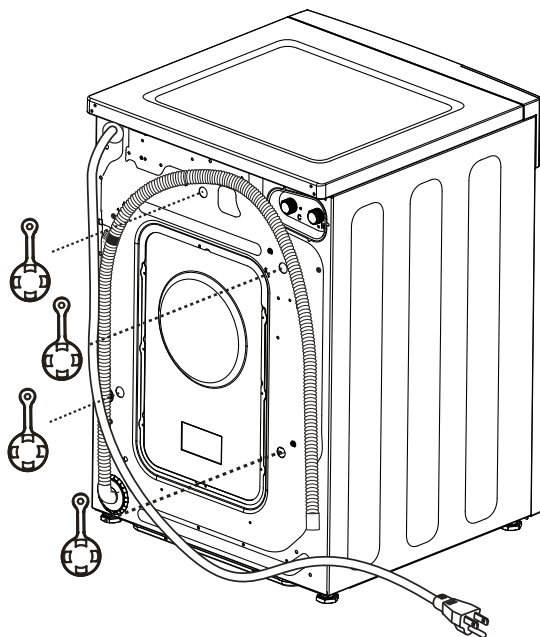

### NOTES:

- Failure to remove the shipping braces can cause the washer to become severely unbalanced.
- **IMPORTANT:** Save all bolts for future use.

If you must transport the washer at a later date, you must reinstall the shipping support hardware to prevent shipping damage. Keep the hardware in the plastic bag provided.

# INSTALLATION INSTRUCTIONS

## ELECTRICAL REQUIREMENTS

### **⚠ WARNING** - Electrical Shock Hazard

Plug into a grounded 3-prong outlet.

**DO NOT** remove ground prong.

**DO NOT** use an adapter.

**DO NOT** use an extension cord.

Failure to follow these instructions can result in death, fire or electrical shock.

**CIRCUIT** – Individual, properly polarized and grounded 15 or 20 amp circuit breaker or time-delay fuse.

**POWER SUPPLY** – 2 wire plus ground, 120 Volt, single phase, 60 Hz, alternating current.

**Outlet Receptacle** – Properly grounded 3-prong receptacle to be located so the power cord is accessible when the washer is in an installed position. If a 2-prong receptacle is present, it is the owner's responsibility to have a licensed electrician replace it with a properly grounded 3-prong grounding type receptacle.

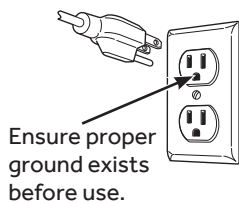

Washer must be electrically grounded in accordance with local codes and ordinances, or in the absence of local codes, with latest edition of the NATIONAL ELECTRICAL CODE, ANSI/NFPA NO. 70 or CANADIAN ELECTRICAL CODE, CSA C22.1. Check with a licensed electrician if you are not sure that the washer is properly grounded.

## GROUNDING INSTRUCTIONS

This appliance must be grounded. In the event of malfunction or breakdown, grounding will reduce the risk of electric shock by providing a path of least resistance for electric current. This appliance is equipped with a cord having an equipment- grounding conductor and a grounding plug. The plug must be plugged into an appropriate outlet that is properly installed and grounded in accordance with all local codes and ordinances.

**⚠ WARNING** Improper connection of the equipment-grounding conductor can result in a risk of electrical shock. Check with a qualified electrician, or service representative or personnel, if you are in doubt as to whether the appliance is properly grounded. **DO NOT** modify the plug on the power supply cord. If it will not fit the outlet, have a proper outlet installed by a qualified electrician.

If required by local codes, an external 18 gauge or larger copper ground wire (not provided) may be added. Attach to washer cabinet with a #10-16 x 1/2" sheet metal screw (available at any hardware store) to rear of washer.

### **⚠ WARNING** - Electrical Shock Hazard

Disconnect power supply before servicing.

Replace all parts and panels before operating.

Failure to do so can result in death or electrical shock.

### **⚠ WARNING** - Shock Hazard

Certain internal parts are intentionally not grounded and may present a risk of electric shock only during servicing.

**Service personnel – DO NOT** contact the following parts while the appliance is energized: Electrical Valve, Drain Pump, NTC and Motor Control Unit.

## WATER SUPPLY REQUIREMENTS

Hot and cold water faucets **MUST** be installed within 42 inches (107 cm) of your washer's water inlet. The faucets **MUST** be 3/4" (1.9 cm) garden hose-type so inlet hoses can be connected. Water pressure **MUST** be between 10 and 120 pounds per square inch. Your water department can advise you of your water pressure. The hot water temperature should be set to deliver water at 120° to 140°F (48°–60°C) to provide proper Automatic Temperature Control (ATC) performance.

## DRAIN REQUIREMENTS

1. Drain capable of eliminating 9.5 gals (36 L) per minute.

2. A standpipe diameter of 1-1/4" (3.18 cm) minimum.

3. The standpipe height above the floor should be:

Minimum height: 36" (91.4 cm)

Maximum height: 58" (147 cm)

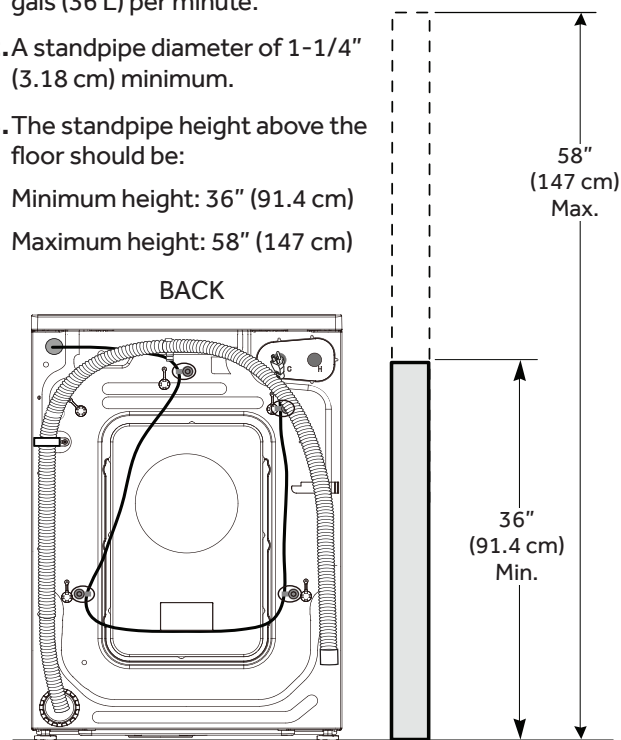

# INSTALLATION INSTRUCTIONS

## INSTALLING THE WASHER

1. Run some water from the hot and cold faucets to flush the water lines and remove particles that might clog the water valve screens.
2. Remove the inlet hoses from the plastic bag. Remove black rubber washers from bag and insert into hose fitting before connecting to unit.

3. (90° elbow end)  
Carefully connect the inlet hose marked HOT to the outside "H" outlet of the water valve. Tighten by hand; then tighten another 2 turn with pliers. Carefully connect the other inlet hose to the inside "C" outlet of the water valve. Tighten by hand; then tighten another 2/3 turn with pliers. **Do not cross-thread or overtighten these connections.**

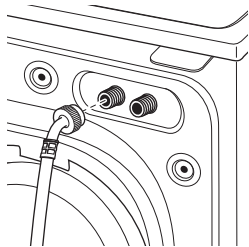

4. Connect the inlet hose ends to the HOT and COLD water faucets tightly by hand; then tighten another 2/3 turn with pliers. Turn the water on and check for leaks.



5. Carefully move the washer to its final location. Gently rock the washer into position. It is important not to damage the rubber leveling legs when moving your washer to its final location. Damaged legs can increase washer vibration. It may be helpful to spray window cleaner on the floor to help move your washer into its final position. **NOTE: To reduce vibration, ensure that all four rubber leveling legs are firmly touching the floor. Push and pull on the back right and then back left of your washer.**

**NOTE:** Do not use the dispenser drawer or door to lift the washer.

**NOTE:** If you are installing into a drain pan, you can use a 24-inch-long 2x4 to lever the washer into place.

6. With the washer in its final position, place a level on top of the washer (if the washer is installed under a counter, the washer should not be able to rock). Adjust the front leveling legs up or down to ensure the washer is resting solidly. Turn the locknuts on each leg up toward the base of the washer and snug with a wrench.

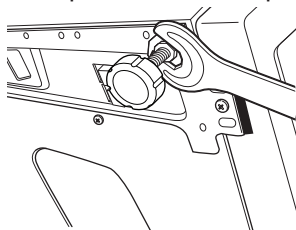

**NOTE: Keep the leg extension at a minimum to prevent excessive vibration. The farther out the legs are extended, the more the washer will vibrate.**

If the floor is not level or is damaged, you may have to extend the rear leveling legs.

## INSTALLING THE WASHER (cont.)

7. Attach U-shaped hose guide to the end of the drain hose. Place the hose in a laundry tub or standpipe.

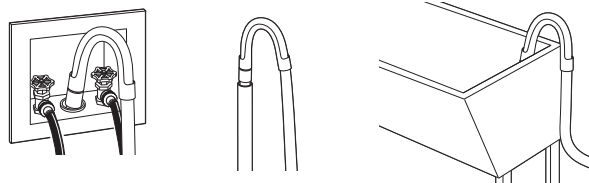

**NOTE:** If the drain hose is placed in a standpipe without forming a U shape, a siphoning action could occur. There must be an air gap around the drain hose. A snug hose fit can also cause a siphoning action.

**NOTE:** Do not place drain hose deeper than 7" into the drain. 4" - 7" is suggested. Deeper than 7" can cause a siphoning action.

8. Plug the power cord into a grounded outlet.

**NOTE:** Check to be sure the power is off at the circuit breaker/fuse box before plugging the power cord into an outlet.

9. Turn on the power at the circuit breaker/fuse box.
10. Read the rest of this Owner's Manual. It contains valuable and helpful information that will save you time and money.

### 11. Before starting the washer, check to make sure:

- Main power is turned on.
- The washer is plugged in.
- The water faucets are turned on.
- The unit is level and all four leveling legs are firmly on the floor.
- The shipping support hardware is removed and saved.
- The drain hose is properly tied up.
- There are no leaks at the faucet, drain line or washer.

12. Run the washer through a complete cycle. Check for water leaks and proper operation.

13. If your washer does not operate, please review the **Troubleshooting Tips** section before contacting us for service.

14. Place these instructions in a location near the washer for future reference.

## REPLACEMENT PARTS

Visit our website at [haierappliances.com/parts](http://haierappliances.com/parts) or in Canada visit [haiercanada.ca/parts](http://haiercanada.ca/parts).

# TROUBLESHOOTING TIPS

Problem	Possible Cause	What To Do
Not draining Not spinning Not tumbling	Load is out of balance	Redistribute clothes and run <b>Rinse+Spin</b> . Increase load size if washing small load containing heavy and light items.
	Pump filter may be clogged	See the <b>Care and Cleaning</b> section on how to clean the <b>Pump Filter</b> .
	Drain hose is kinked or improperly connected	Straighten drain hose and make sure washer is not sitting on it.
	Household drain may be clogged	Check household plumbing. You may need to call a plumber.
	Drain hose siphoning; drain hose pushed too far down the drain	Ensure there is an air gap between hose and drain.
Leaking water	Door gasket is damaged	Check to see if gasket is seated and not torn. Objects left in pockets may cause damage to the washer (nails, screws, pens, pencils) Water may drip from the door when the door is opened. This is a normal operation. Carefully wipe off rubber door seal. Sometimes dirt or clothing is left in this seal and can cause a small leak
	Check back left of washer for water	If this area is wet, you have oversudsing condition. Use less detergent.
	Fill hoses or drain hose is improperly connected	Make sure hose connections are tight at washer and faucets and make sure end of drain hose is correctly inserted in and secured to drain facility.
	Household drain may be clogged	Check household plumbing. You may need to call a plumber.
	Dispenser clogged	Powder soap may cause clogs inside the dispenser and cause water to leak out the front of the dispenser. Remove drawer and clean both drawer and inside of dispenser box. Please refer to <b>Care and Cleaning</b> section.
	Incorrect use of detergent	Use only HE and correct amount of detergent.
Clothes too wet	Load is out of balance	Redistribute clothes and run <b>Rinse+Spin</b> .
		Increase load size if washing small load containing heavy and light items.
	Pump filter may be clogged	See the <b>Care and Cleaning</b> section on how to clean the <b>Pump Filter</b> .
	Overloading	Load your washer so clothes have enough room to move freely.
	Drain hose is kinked or improperly connected	Straighten drain hose and make sure washer is not sitting on it.
	Household drain may be clogged	Check household plumbing. You may need to call a plumber.
	Drain hose siphoning; drain hose pushed too far down the drain	Ensure there is an air gap between hose and drain.

## TROUBLESHOOTING TIPS

Problem	Possible Cause	What To Do
Incomplete cycle or timer not advancing	<b>Automatic load redistribution</b>	Timer stops at 1 minute; machine has redistributed the load once or twice. This is normal operation. Do nothing; the machine will finish the wash cycle.
	<b>Pump filter may be clogged</b>	See the <b>Care and Cleaning</b> section on how to clean the <b>Pump Filter</b> .
	<b>Drain hose is kinked or improperly connected</b>	Straighten drain hose and make sure washer is not sitting on it.
	<b>Household drain may be clogged</b>	Check household plumbing. You may need to call a plumber.
	<b>Drain hose siphoning; drain hose pushed too far down the drain</b>	Ensure there is an air gap between hose and drain.
Loud or unusual noise; vibration or shaking	<b>Cabinet moving</b>	Washer is designed to move 1/4" to reduce forces transmitted to the floor. This movement is normal.
	<b>All rubber leveling legs are not firmly touching the floor</b>	Push and pull on the back right and then back left of your washer to check if it is level. If the washer is uneven, adjust the rubber leveling legs so they are all firmly touching the floor and locked in place.
	<b>Unbalanced load</b>	Pause unit, open door and manually redistribute load. To check machine, run rinse and spin with no load. If normal, unbalance was caused by load.
	<b>Pump filter may be clogged</b>	See the <b>Care and Cleaning</b> section on how to clean the <b>Pump Filter</b> .
No power/washer not working or dead	<b>Washer is unplugged</b>	Make sure cord is plugged securely into a working outlet.
	<b>Water supply is turned off</b>	Turn both hot and cold faucets fully on.
	<b>Circuit breaker/fuse is tripped/blown</b>	Check house circuit breakers/fuses. Replace fuses or reset breaker. Washer should have separate outlet.
	<b>Automatic self system checks</b>	First time the washer is plugged in, automatic checks occur. It may take up to 20 seconds before you can use your washer. This is normal operation.
Snags, holes, tears, rips or excessive wear	<b>Pens, pencils, nails, screws or other objects left in pockets</b>	Remove loose items from pockets.
	<b>Pins, snaps, hooks, sharp buttons, belt buckles, zippers and sharp objects left in pockets</b>	Fasten snaps, hooks, buttons and zippers.
Control time wrong or changes	<b>This is normal</b>	During spin the washer may need to rebalance the load sometimes to reduce vibrations. When this happens, the estimated time is increased causing time left to increase or jump.
Not enough water	<b>This is normal</b>	Horizontal washers do not require the tub to fill with water like top-load washers.
Washer pauses or has to be restarted, or washer door is locked and will not open	<b>Pump filter may be clogged</b>	See the <b>Care and Cleaning</b> section on how to clean the <b>Pump Filter</b> .
Door unlocks or press Start and machine doesn't operate	<b>This is normal</b>	Front-load washers start up differently than top-load washers, and it takes several seconds to check the system. The door will lock and unlock.
	<b>Incorrect operation</b>	Simply open and close the door firmly; then press <b>Start</b> .

# TROUBLESHOOTING TIPS

Problem	Possible Cause	What To Do
Water does not enter washer or enters slowly	<b>Automatic self system checks</b>	After <b>Start</b> is pressed, the washer does several system checks. Water will flow several seconds after <b>Start</b> is pressed.
	<b>Water valve screens are stopped up</b>	Turn off the water source and remove the water connection hoses from the upper back of the washer. Use a brush or toothpick to clean the screens in the machine. Reconnect the hoses and turn the water back on.
	<b>Inlet hose screen washers are stopped up</b>	Turn off the water source and remove the inlet hoses from the wall faucets. Use a brush or toothpick to clean the screen washers in the end of the hoses. Reconnect the hoses and turn the water back on.
	<b>Pump filter may be clogged</b>	See the <b>Care and Cleaning</b> section on how to clean the <b>Pump Filter</b> .
	<b>Fill hoses may be kinked</b>	Check that fill hoses are not kinked or clogged.
	<b>Water supply is turned off</b>	Turn on both hot and cold faucets fully.
	<b>Energy efficiency</b>	This is an energy-efficient washer. As a result, the temperature settings for this washer may be different than for a non-energy-efficient washer.
	<b>Insufficient water supply</b>	Make sure that the water supply is turned on. Make sure that the water faucets are turned to their completely open position.
	<b>The washer door is open</b>	The washer door must be closed for all washer cycle operations. If the door is opened during the washer operation, all functions will stop, including water filling.
	<b>Incorrect fill hose connection</b>	Make sure that the fill hoses connect the hot water supply to the hot inlet on the washer and the cold water supply to the cold inlet on the washer (hot to hot, cold to cold).
Wrinkling	<b>Improper sorting</b>	Avoid mixing heavy items (like work clothes) with light items (like blouses).
	<b>Overloading</b>	Load your washer so clothes have enough room to move freely.
	<b>Incorrect wash cycle</b>	Match cycle selection to the type of fabric you are washing (especially for easy care loads).
	<b>Repeated washing in water that is too hot</b>	Wash in warm or cold water.
Grayed or yellowed clothes	<b>Not enough detergent</b>	Use correct amount of detergent.
	<b>Not using HE (high efficiency) detergent</b>	Use only HE detergent.
	<b>Hard water</b>	Use hottest water safe for fabric.
		Use a water conditioner like Calgon brand or install a water softener.
	<b>Water is not hot enough</b>	Make sure water heater is delivering water at 120°–140°F (48°–60°C).
	<b>Detergent is not dissolving</b>	Try a liquid HE detergent.
<b>Dye transfer</b>	Sort clothes by color. If fabric label states wash separately, unstable dyes may be indicated.	

## TROUBLESHOOTING TIPS

Problem	Possible Cause	What To Do
Colored spots	Incorrect use of fabric softener	Check fabric softener package for instructions and follow directions for using dispenser.
	Dye transfer	Sort whites or lightly colored items from dark colors. Promptly remove wash load from washer.
Water temperature is incorrect	Water supply is improperly connected	Make sure hoses are connected to correct faucets.
	House water heater is not set properly	Make sure house water heater is delivering water at 120°–140°F (48°–60°C).
Slight variation in metallic color	This is normal	Due to the metallic properties of paint used for this unique product, slight variations of color may occur due to viewing angles and lighting conditions.
Bad odor inside your Washer	Washer unused for a long time, not using recommended quality of HE detergent or used too much detergent	Run a <b>Tub Clean</b> cycle.
		In case of strong odor, you may need to run the <b>Tub Clean</b> cycle more than once.
		Use only the amount of detergent recommended on the detergent container.
		Use only HE (high efficiency) detergent.
		Always remove wet items from the washer promptly after machine stops running. Leave the door slightly open for the water to air dry. Close supervision is necessary if this appliance is used by or near children. Do not allow children to play on or in this or any other appliance.
Detergent leak	Incorrect placement of detergent insert	Make sure detergent insert is properly located and fully seated. Never put detergent above max line.
	This is normal	It is normal operation to see detergent leak on door gasket about 20 seconds after filling the dispenser.
Improper dispensing of softener	Dispenser clogged	Monthly clean the dispenser drawer to remove buildup of chemicals.
	Softener is filled above the max line	Make sure to have the correct amount of softener.
	Softener cap issue	Make sure softener cap for dispenser is seated or it will not work.
Dispenser drawer not dispensing properly	Laundry detergent packet placed in dispenser drawer	Laundry detergent packets should not be used in the dispenser. They should only be added directly to the wash tub following the manufacturer's directions.
Pump running while washer is not in use	Clog in sump drain	This is normal. Drain sump is detecting an undesired water fill level from a potential open faucet. Shut off water valve and inspect water valve for blockage.



# NOTES

# NOTES

# LIMITED WARRANTY

## haierappliances.com

All warranty service is provided by our Factory Service Centers, or an authorized Customer Care® technician. To schedule service online, visit us at [haierappliances.com/support/schedule-service](http://haierappliances.com/support/schedule-service) or in Canada [haiercanada.ca/service](http://haiercanada.ca/service). Please have your serial number and your model number available when contacting us for service.

Servicing your appliance may require the use of the onboard data port for diagnostics. This gives a Haier Appliances factory service technician the ability to quickly diagnose any issues with your appliance and helps Haier Appliances improve its products by providing Haier Appliances with information on your appliance. If you do not want your appliance data to be sent to Haier Appliances, please advise your technician not to submit the data to Haier Appliances at the time of service.

For the period of	Haier Appliances will replace
<b>One year</b> From date of the original purchase	<b>Any part</b> of the washer which fails due to a defect in materials or workmanship. During this <b>limited one-year warranty</b> , Haier Appliances will provide, <b>free of charge</b> , all labor and in-home service to replace the defective part.

### What Haier Appliances will not cover (for customers in the United States):

- Service trips to your home to teach you how to use the product.
- Improper installation, delivery or maintenance.
- Failure of the product if it is abused, misused, or used for other than the intended purpose or used commercially.
- Replacement of house fuses or resetting of circuit breakers.
- Products which are not defective or broken, or which are working as described in the Owner's Manual.
- Damage to the product caused by accident, fire, floods or acts of God.
- Incidental or consequential damage caused by possible defects with this appliance.
- Defects or damage due to operation in freezing temperatures.
- Damage caused after delivery.
- Product not accessible to provide required service.

This limited warranty is extended to the original purchaser and any succeeding owner for products purchased for home use within the USA. If the product is located in an area where service by a Haier Appliances Authorized Servicer is not available, you may be responsible for a trip charge or you may be required to bring the product to an Authorized Haier Appliances Service location for service. In Alaska, the limited warranty excludes the cost of shipping or service calls to your home.

Some states do not allow the exclusion or limitation of incidental or consequential damages. This limited warranty gives you specific legal rights, and you may also have other rights which vary from state to state. To know what your legal rights are, consult your local or state consumer affairs office or your state's Attorney General.

**Warrantor: Haier Appliances, Louisville, KY 40225**

### What Haier Appliances will not cover (for customers in Canada):

- Service trips to your home to teach you how to use the product.
- Improper installation.  
If you have an installation problem, contact your dealer or installer. You are responsible for providing adequate electrical, exhausting and other connecting facilities.
- Failure of the product if it is abused, misused or used for other than the intended purpose or used commercially.
- Replacement of house fuses or resetting of circuit breakers.
- Damage to the product caused by accident, fire, floods, or acts of God.
- Damage caused after delivery including damage from items dropped on the door.

This limited warranty is extended to the original purchaser and any succeeding owner for products purchased in Canada for home use within Canada. In home warranty service will be provided in areas where it is available and deemed reasonable by Mabe to provide.

**WARRANTOR IS NOT RESPONSIBLE FOR CONSEQUENTIAL DAMAGES.**

**Warrantor: MC Commercial Inc., Burlington, ON, L7R 5B6**

### EXCLUSION OF IMPLIED WARRANTIES

Your sole and exclusive remedy is product repair as provided in this Limited Warranty. Any implied warranties, including the implied warranties of merchantability or fitness for a particular purpose, are limited to one year or the shortest period allowed by law.

Staple your receipt here. Proof of the original purchase date is needed to obtain service under the warranty.

# CONSUMER SUPPORT

## Haier Appliances Website

Have a question or need assistance with your appliance? Try the Haier Appliances Website 24 hours a day, any day of the year! You can also shop for more great Haier Appliances products and take advantage of all our on-line support services designed for your convenience. In the US: [haierappliances.com](http://haierappliances.com)

---

## Register Your Appliance

Register your new appliance on-line at your convenience! Timely product registration will allow for enhanced communication and prompt service under the terms of your warranty, should the need arise. You may also mail in the pre-printed registration card included in the packing material. In the US: [haierappliances.com/support/register](http://haierappliances.com/support/register)

In Canada: [prodsupport.mabe.ca/crm/Products/ProductRegistration.aspx](http://prodsupport.mabe.ca/crm/Products/ProductRegistration.aspx)

---

## Schedule Service

Expert Haier Appliances repair service is only one step away from your door. Get on-line and schedule your service at your convenience any day of the year. In the US: [haierappliances.com/support/schedule-service](http://haierappliances.com/support/schedule-service).

In Canada: [haiercanada.ca/service](http://haiercanada.ca/service)

---

## Remote Connectivity

For assistance with wireless network connectivity (for models with remote enable), visit our website in the US at [haierappliances.com](http://haierappliances.com)

---

## Parts and Accessories

Individuals qualified to service their own appliances can have parts or accessories sent directly to their homes (VISA, MasterCard and Discover cards are accepted).

In the US: [haierappliances.com/parts](http://haierappliances.com/parts)

In Canada: [haiercanada.ca/parts](http://haiercanada.ca/parts)

**Instructions contained in this manual cover procedures to be performed by any user. Other servicing generally should be referred to qualified service personnel. Caution must be exercised, since improper servicing may cause unsafe operation.**

---

## Contact Us

If you are not satisfied with the service you receive from Haier Appliances, contact us on our website at [haierappliances.com/support/contact-us](http://haierappliances.com/support/contact-us) with all the details including your phone number, or write to:

In the US: Haier Appliances, Consumer Relations | PO Box 1780 | Rapid City, SD 57709

In Canada: [haiercanada.ca/contact-us](http://haiercanada.ca/contact-us)