

# INSTALLATION INSTRUCTIONS 30" (76.2 CM) SLIDE-IN GAS RANGES

## INSTRUCTIONS POUR L'INSTALLATION DES CUISINIÈRES À GAZ ENCASTRABLES DE 30" (76,2 CM)

---

### Table of Contents

<b>RANGE SAFETY</b> .....	<b>2</b>
<b>INSTALLATION REQUIREMENTS</b> .....	<b>4</b>
Tools and Parts.....	4
Location Requirements .....	4
Electrical Requirements .....	7
Gas Supply Requirements .....	7
<b>INSTALLATION INSTRUCTIONS</b> .....	<b>9</b>
Unpack Range.....	9
Install Anti-Tip Bracket.....	9
Adjust Leveling Legs .....	10
Level Range.....	11
Make Gas Connection .....	11
Verify Anti-Tip Bracket Is Installed and Engaged .....	13
Electronic Ignition System .....	13
Remove/Replace Drawer.....	14
Oven Door .....	14
Complete Installation .....	15
<b>GAS CONVERSIONS</b> .....	<b>16</b>
Propane Gas Conversion.....	16
Natural Gas Conversion .....	19
Adjust Flame Height.....	22

### Table des matières

<b>SÉCURITÉ DE LA CUISINIÈRE</b> .....	<b>24</b>
<b>EXIGENCES D'INSTALLATION</b> .....	<b>26</b>
Outils et pièces.....	26
Exigences d'emplacement.....	26
Spécifications électriques.....	29
Spécifications de l'alimentation en gaz .....	29
<b>INSTRUCTIONS D'INSTALLATION</b> .....	<b>31</b>
Déballage de la cuisinière .....	31
Installation de la bride antibasculement .....	31
Réglage des pieds de nivellement.....	32
Réglage de l'aplomb de la cuisinière.....	33
Raccordement au gaz.....	33
Vérifier que la bride antibasculement est bien installée et engagée .....	35
Système d'allumage électronique.....	36
Dépose et réinstallation du tiroir .....	37
Porte du four .....	37
Achever l'installation .....	38
<b>CONVERSIONS POUR CHANGEMENT DE GAZ</b> .....	<b>39</b>
Conversion pour l'alimentation au propane .....	39
Conversion pour l'alimentation au gaz naturel .....	43
Réglage de la taille des flammes .....	46

---

#### **IMPORTANT:**

**Installer:** Leave installation instructions with the homeowner.

**Homeowner:** Keep installation instructions for future reference.

#### **IMPORTANT :**

**Installateur :** Remettre les instructions d'installation au propriétaire.

**Propriétaire :** Conserver les instructions d'installation pour référence ultérieure.

# RANGE SAFETY

## Your safety and the safety of others are very important.

We have provided many important safety messages in this manual and on your appliance. Always read and obey all safety messages.



This is the safety alert symbol.

This symbol alerts you to potential hazards that can kill or hurt you and others.

All safety messages will follow the safety alert symbol and either the word “DANGER” or “WARNING.”

These words mean:

**⚠ DANGER**

You can be killed or seriously injured if you don't immediately follow instructions.

**⚠ WARNING**

You can be killed or seriously injured if you don't follow instructions.

All safety messages will tell you what the potential hazard is, tell you how to reduce the chance of injury, and tell you what can happen if the instructions are not followed.

**WARNING: If the information in these instructions is not followed exactly, a fire or explosion may result causing property damage, personal injury or death.**

- Do not store or use gasoline or other flammable vapors and liquids in the vicinity of this or any other appliance.
- **WHAT TO DO IF YOU SMELL GAS:**
  - Do not try to light any appliance.
  - Do not touch any electrical switch.
  - Do not use any phone in your building.
  - Immediately call your gas supplier from a neighbor's phone. Follow the gas supplier's instructions.
  - If you cannot reach your gas supplier, call the fire department.
- Installation and service must be performed by a qualified installer, service agency or the gas supplier.

**WARNING:** Gas leaks cannot always be detected by smell.

Gas suppliers recommend that you use a gas detector approved by UL or CSA.

For more information, contact your gas supplier.

If a gas leak is detected, follow the “What to do if you smell gas” instructions.

**IMPORTANT:** Do not install a ventilation system that blows air downward toward this gas cooking appliance. This type of ventilation system may cause ignition and combustion problems with this gas cooking appliance resulting in personal injury or unintended operation.

In the State of Massachusetts, the following installation instructions apply:

- Installations and repairs must be performed by a qualified or licensed contractor, plumber, or gasfitter qualified or licensed by the State of Massachusetts.
- Acceptable Shut-off Devices: Gas Cocks and Ball Valves installed for use shall be listed.
- A flexible gas connector, when used, must not exceed 4 feet (121.9 cm).



## **⚠ WARNING**

### **Tip Over Hazard**

**A child or adult can tip the range and be killed.**

**Install anti-tip bracket to floor or wall per installation instructions.**

**Slide range back so rear range foot is engaged in the slot of the anti-tip bracket.**

**Re-engage anti-tip bracket if range is moved.**

**Do not operate range without anti-tip bracket installed and engaged.**

**Failure to follow these instructions can result in death or serious burns to children and adults.**

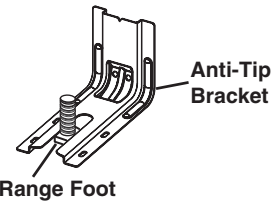

**To verify the anti-tip bracket is installed and engaged:**

- Slide range forward.
- Look for the anti-tip bracket securely attached to floor or wall.
- Slide range back so rear range foot is under anti-tip bracket.
- See installation instructions for details.

# INSTALLATION REQUIREMENTS

## Tools and Parts

Gather the required tools and parts before starting installation. Read and follow the instructions provided with any tools listed here.

### Tools Needed

- Tape measure
- Phillips screwdriver
- Flat-blade screwdriver
- 1/8" (3.2 mm) flat-blade screwdriver
- Level
- Drill
- Wrench or pliers
- Pipe wrench
- 15/16" (2.4 cm) combination wrench
- 1/8" (3.2 mm) drill bit (for wood floors)
- Marker or pencil
- Pipe-joint compound resistant to propane gas
- 3/16" (4.8 mm) carbide-tipped masonry drill bit (for concrete/ceramic floors)
- Noncorrosive leak-detection solution

### For propane/Natural Gas Conversions

- 5/8" (1.6 cm) combination wrench
- 3/8" (1 cm) nut driver
- 9/32" (7.1 mm) nut driver
- Masking tape

### Parts Supplied

Check that all parts are included.

- Propane/Natural Gas Conversion Kit
- #10 x 1<sup>5</sup>/<sub>8</sub>" (4.1 cm) screws (for mounting anti-tip bracket) (2)
- Anti-tip bracket (inside oven cavity)  
Anti-tip bracket must be securely mounted to the back wall or floor. Thickness of flooring may require longer screws to anchor bracket to subfloor. Longer screws are available from your local hardware store.

### Parts Needed

Check local codes and consult gas supplier. Check existing gas supply and electrical supply. See "Electrical Requirements" and "Gas Supply Requirements" sections.

**IMPORTANT:** When the range is used under microwave models: JMC82808CB-0, JMV9196CB-0, or YJMV9196CB-0, the Door Baffle Plate Part Number W10737014 must be ordered and used. Please reference the "Accessories" section of the User Guide for contact information.

### Optional Parts

To purchase these or any other accessories, please reference the "Accessories" section of the User Guide for contact information.

#### Side Trim Kits:

- 5/8" (1.6 cm) White - Order Part Number W10675027
- 5/8" (1.6 cm) Black - Order Part Number W10675026
- 5/8" (1.6 cm) Stainless Steel - Order Part Number W10675028
- 1<sup>1</sup>/<sub>8</sub>" (2.9 cm) White - Order Part Number W10731885
- 1<sup>1</sup>/<sub>8</sub>" (2.9 cm) Black - Order Part Number W10731886
- 1<sup>1</sup>/<sub>8</sub>" (2.9 cm) Stainless Steel - Order Part Number W10731887

#### Backsplash Kits:

- High 6" (15.2 cm) White - Order Part Number W10655448
- High 6" (15.2 cm) Black - Order Part Number W10655449
- High 6" (15.2 cm) Stainless Steel - Order Part Number W10655450

## Location Requirements

**IMPORTANT:** Observe all governing codes and ordinances. Do not obstruct flow of combustion and ventilation air.

- It is the installer's responsibility to comply with installation clearances specified on the model/serial/rating plate. The model/serial/rating plate is located behind the oven door on the top right-hand side of the oven frame.
- The range should be located for convenient use in the kitchen.
- Recessed installations must provide complete enclosure of the sides and rear of the range.
- All openings in the wall or floor where range is to be installed must be sealed.
- Cabinet opening dimensions that are shown must be used. Given dimensions are minimum clearances.
- The anti-tip bracket must be installed. To install the anti-tip bracket shipped with the range, see "Install Anti-Tip Bracket" section.
- Grounded electrical supply is required. See "Electrical Requirements" section.
- Proper gas supply connection must be available. See "Gas Supply Requirements" section.
- Contact a qualified floor covering installer to check that the floor covering can withstand at least 200°F (93°C).
- Use an insulated pad or 1/4" (6.4 mm) plywood under range if installing range over carpeting.

**IMPORTANT:** To avoid damage to your cabinets, check with your builder or cabinet supplier to make sure that the materials used will not discolor, delaminate or sustain other damage. This oven has been designed in accordance with the requirements of UL and CSA International and complies with the maximum allowable wood cabinet temperatures of 194°F (90°C).

## Mobile Home - Additional Installation Requirements

The installation of this range must conform to the Manufactured Home Construction and Safety Standard, Title 24 CFR, Part 3280 (formerly the Federal Standard for Mobile Home Construction and Safety, Title 24, HUD Part 280). When such standard is not applicable, use the Standard for Manufactured Home Installations, ANSI A225.1/NFPA 501A or with local codes.

In Canada, the installation of this range must conform with the current standards CAN/CSA-A240-latest edition, or with local codes.

### Mobile Home Installations Require:

- When this range is installed in a mobile home, it must be secured to the floor during transit. Any method of securing the range is adequate as long as it conforms to the standards listed above.

## Product Dimensions

This manual covers several models. Your model may appear different from the models depicted. Dimensions given are maximum dimensions across all models.

### Model KSGB900

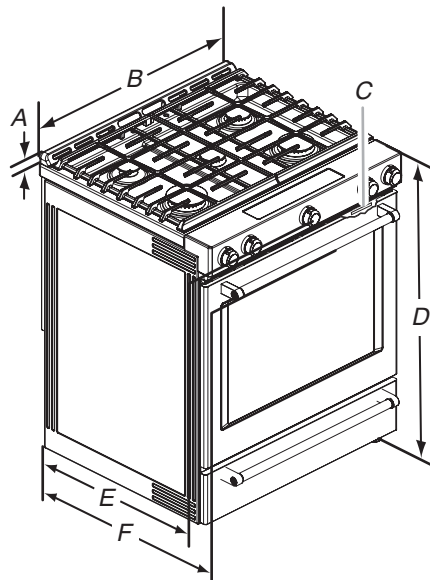

- A.  $1\frac{3}{16}$ " (3.0 cm) height from cooktop to top of vent
- B.  $29\frac{7}{8}$ " (75.9 cm)
- C. Model/serial/rating plate (located behind the oven door on the top right-hand side of the oven frame)
- D. 36" (91.4 cm) height to top of cooktop edge with leveling legs screwed in all the way\*
- E.  $28\frac{5}{16}$ " (71.9 cm) max. depth from front of console to back of range
- F.  $28\frac{7}{8}$ " (73.3 cm) max. depth from handle to back of range

**IMPORTANT:** Range must be level after installation. Follow the instructions in the "Level Range" section. Using the cooktop as a reference for leveling the range is not recommended.

\*Range can be raised approximately 1" (2.5 cm) by adjusting the leveling legs.

## Cabinet Dimensions

Cabinet opening dimensions shown are for 25" (64.0 cm) countertop depth, 24" (61.0 cm) base cabinet depth and 36" (91.4 cm) countertop height.

**IMPORTANT:** If installing a range hood or microwave hood combination above the cooking surface, follow the range hood or microwave hood combination installation instructions for dimensional clearances above the cooktop surface.

Range may be installed next to combustible walls with zero clearance.

**NOTE:** When installed in a slide-in cutout, the front of oven door may protrude beyond the base cabinet.

### Slide-in Cutout

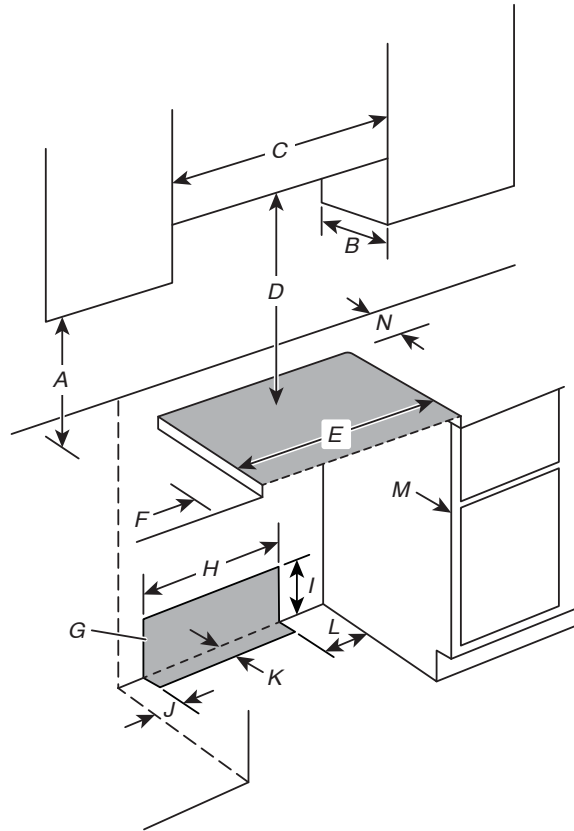

- A. 18" (45.7 cm) upper side cabinet to countertop
- B. 13" (33 cm) max. upper cabinet depth
- C. 30" (76.2 cm) min. opening width
- D. For minimum clearance to top of cooktop, see NOTE\*.
- E. 30" (76.2 cm) min. opening width
- F. 5" (12.7 cm) min. clearance from both sides of range to side wall or other combustible material
- G. The shaded area is recommended for installation of rigid gas pipe and grounded outlet.
- H. 13<sup>1</sup>/<sub>8</sub>" (33.3 cm)
- I. 7<sup>1</sup>/<sub>16</sub>" (19.5 cm)
- J. 4<sup>13</sup>/<sub>16</sub>" (12.2 cm)
- K. 3<sup>1</sup>/<sub>16</sub>" (9.4 cm) plus measurement of N
- L. 12" (30.5 cm)
- M. Cabinet door or hinges should not extend into the cutout.
- N. Remaining counter depth should not exceed 2<sup>1</sup>/<sub>4</sub>" (5.7 cm).

**\*NOTE:** 24" (61.0 cm) minimum when bottom of wood or metal cabinet is shielded by not less than 1/4" (6.4 mm) flame retardant millboard covered with not less than No. 28 MSG sheet steel, 0.015" (0.4 mm) stainless steel, 0.024" (0.6 mm) aluminum or 0.020" (0.5 mm) copper.

30" (76.2 cm) minimum clearance between the top of the cooking platform and the bottom of an uncovered wood or metal cabinet.

## Electrical Requirements

### **⚠ WARNING**



#### Electrical Shock Hazard

- Plug into a grounded 3 prong outlet.
- Do not remove ground prong.
- Do not use an adapter.
- Do not use an extension cord.
- Failure to follow these instructions can result in death, fire, or electrical shock.

**IMPORTANT:** The range must be electrically grounded in accordance with local codes and ordinances, or in the absence of local codes, with the National Electrical Code, ANSI/NFPA 70 or Canadian Electrical Code, CSA C22.1.

This range is equipped with an electronic ignition system that will not operate properly if plugged into an outlet that is not properly polarized.

If codes permit and a separate ground wire is used, it is recommended that a qualified electrical installer determine that the ground path is adequate.

A copy of the above code standards can be obtained from:

National Fire Protection Association  
1 Batterymarch Park  
Quincy, MA 02169-7471  
CSA International  
8501 East Pleasant Valley Road  
Cleveland, OH 44131-5575

- A 120 V, 60 Hz, AC only, 15 A fused, ground and polarized electrical circuit is required. A time-delay fuse or circuit breaker is also recommended. It is recommended that a separate circuit serving only this range be provided.
- Electronic ignition systems operate within wide voltage limits, but proper grounding and polarity are necessary. Check that the outlet provides 120 V power and is correctly grounded.
- This gas range is not required to be plugged into a GFCI (Ground-Fault Circuit Interrupter) outlet. It is recommended that you not plug an electric spark ignition gas range or any other major appliance into a GFCI wall outlet as it may cause the GFCI to trip during normal cycling.
- Performance of this range will not be affected if operated on a GFCI-protected circuit. However, occasional nuisance tripping of the GFCI breaker is possible due to the normal operating nature of electronic gas ranges.
- The tech sheet and wiring diagram are located on the back of the range in a plastic bag.

**NOTE:** The metal chassis of the range must be grounded in order for the control panel to work. If the metal chassis of the range is not grounded, no keypads will operate. Check with a qualified electrician if you are in doubt as to whether the metal chassis of the range is grounded.

## Gas Supply Requirements

### **⚠ WARNING**



#### Explosion Hazard

- Use a new CSA International approved gas supply line.
- Install a shut-off valve.
- Securely tighten all gas connections.
- If connected to propane, have a qualified person make sure gas pressure does not exceed 14" (36 cm) water column.
- Examples of a qualified person include:  
licensed heating personnel,  
authorized gas company personnel, and  
authorized service personnel.
- Failure to do so can result in death, explosion, or fire.

Observe all governing codes and ordinances.

**IMPORTANT:** This installation must conform with all local codes and ordinances. In the absence of local codes, installation must conform with American National Standard, National Fuel Gas Code ANSI Z223.1 - latest edition or CAN/CGA B149 - latest edition.

**IMPORTANT:** Leak testing of the range must be conducted according to the manufacturer's instructions.

### Type of Gas

#### Natural Gas:

- This range is factory set for use with Natural gas. See "Gas Conversions" section. The model/serial/rating plate located on the oven frame behind the top right-hand side of the oven door has information on the types of gas that can be used. If the types of gas listed do not include the type of gas available, check with the local gas supplier.

#### Propane Gas Conversion:

Conversion must be done by a qualified service technician. No attempt shall be made to convert the appliance from the gas specified on the model/serial/rating plate for use with a different gas without consulting the serving gas supplier. See "Gas Conversions" section.

### Gas Supply Line

- Provide a gas supply line of 3/4" (1.9 cm) rigid pipe to the range location. A smaller size pipe on longer runs may result in insufficient gas supply. With propane gas, piping or tubing size can be 1/2" (1.3 cm) minimum. Usually, propane gas suppliers determine the size and materials used in the system.  
**NOTE:** Pipe-joint compounds that resist the action of propane gas must be used. Do not use TEFLON<sup>†</sup> tape.

<sup>†</sup>TEFLON is a registered trademark of Chemours.

### Flexible Metal Appliance Connector:

- If local codes permit, a new CSA design-certified, 4 to 5 ft (122 to 152.4 cm) long, 1/2" or 3/4" (1.3 or 1.9 cm) I.D. (inside diameter), flexible metal appliance connector may be used for connecting range to the gas supply line.



- A 1/2" (1.3 cm) male pipe thread is needed for connection to the female pipe threads of the inlet to the appliance pressure regulator.
- Do not kink or damage the flexible metal tubing when moving the range.
- Must include a shut-off valve:  
Install a manual gas line shut-off valve in an easily accessible location. Do not block access to shut-off valve. The valve is for turning on or shutting off gas to the range.

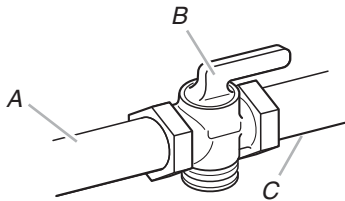

- A. Gas supply line
- B. Shut-off valve "open" position
- C. To range

---

### Gas Pressure Regulator

---

The gas pressure regulator supplied with this range must be used. The inlet pressure to the regulator should be as follows for proper operation:

#### Natural Gas:

Minimum pressure: 5" (12.7 cm) WCP  
Maximum pressure: 14" (35.5 cm) WCP

#### Propane Gas:

Minimum pressure: 11" (28 cm) WCP  
Maximum pressure: 14" (35.5 cm) WCP

Contact local gas supplier if you are not sure about the inlet pressure.

---

### Burner Input Requirements

---

Input ratings shown on the model/serial/rating plate are for elevations up to 2,000 ft (609.6 m).

For elevations above 2,000 ft (609.6 m), ratings are reduced at a rate of 4% for each 1,000 ft (304.8 m) above sea level (not applicable for Canada).

---

### Gas Supply Pressure Testing

---

Gas supply pressure for testing regulator must be at least 1" water column pressure above the manifold pressure shown on the model/serial/rating plate.

#### Line pressure testing above 1/2 psi (3.5 kPa) gauge (14" [35.5 cm] WCP)

The range and its individual shut-off valve must be disconnected from the gas supply piping system during any pressure testing of that system at test pressures in excess of 1/2 psi (3.5 kPa).

#### Line pressure testing at 1/2 psi (3.5 kPa) gauge (14" [35.5 cm] WCP) or lower

The range must be isolated from the gas supply piping system by closing its individual manual shut-off valve during any pressure testing of the gas supply piping system at test pressures equal to or less than 1/2 psi (3.5 kPa).



# INSTALLATION INSTRUCTIONS

## Unpack Range

### **⚠ WARNING**

#### **Excessive Weight Hazard**

**Use two or more people to move and install range.**  
**Failure to do so can result in back or other injury.**

1. Remove shipping materials, tape and film from the range. Keep cardboard bottom under range. Do not dispose of anything until the installation is complete.
2. Remove oven racks and parts package from oven and shipping materials.
3. To remove cardboard bottom, first take 4 cardboard corners from the carton. Stack one cardboard corner on top of another. Repeat with the other 2 corners. Place them lengthwise on the floor behind the range to support the range when it is laid on its back.
4. Using 2 or more people, firmly grasp the range and gently lay it on its back on the cardboard corners.
5. Remove cardboard bottom.

The leveling legs can be adjusted while the range is on its back. See the "Adjust Leveling Legs" section.

**NOTE:** To place range back up into a standing position, put a sheet of cardboard or hardboard on the floor in front of range to protect the flooring. Using 2 or more people, stand range back up onto the cardboard or hardboard.

## Install Anti-Tip Bracket

### **⚠ WARNING**



#### **Tip Over Hazard**

**A child or adult can tip the range and be killed.**

**Install anti-tip bracket to floor or wall per installation instructions.**

**Slide range back so rear range foot is engaged in the slot of the anti-tip bracket.**

**Re-engage anti-tip bracket if range is moved.**

**Do not operate range without anti-tip bracket installed and engaged.**

**Failure to follow these instructions can result in death or serious burns to children and adults.**

1. Remove the anti-tip bracket from the inside of the oven.
2. Determine which mounting method to use: floor or wall.  
If you have a stone or masonry floor, you can use the wall mounting method. If you are installing the range in a mobile home, you must secure the range to the floor.  
This anti-tip bracket and screws can be used with wood or metal studs.
3. Determine and mark centerline of the cutout space. The mounting bracket can be installed on either the left-hand or right-hand side of the cutout. Position mounting bracket against the wall in the cutout so that the V-notch of the bracket is 12½" (31.8 cm) from centerline, as shown.

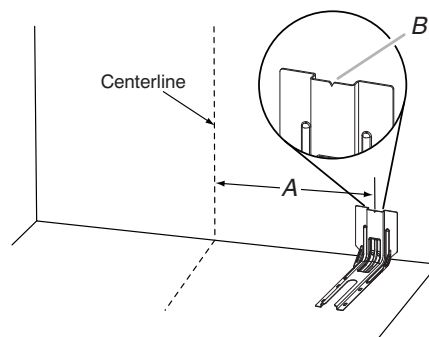

A. 12½" (31.8 cm)

B. Bracket V-notch

- Drill two 1/8" (3 mm) holes that correspond to the bracket holes of the determined mounting method. See the following illustrations.

### Floor Mounting

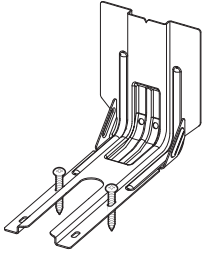

Rear position

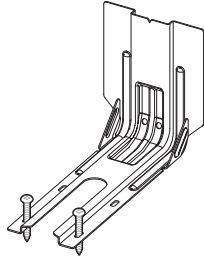

Front position

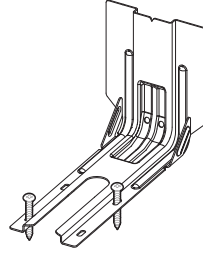

Diagonal (2 options)

### Wall Mounting

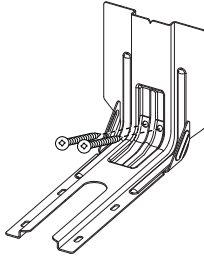

- Using the two #10 x 1<sup>5</sup>/<sub>8</sub>" (4.1 cm) Phillips-head screws provided, mount anti-tip bracket to the wall or floor.
- Move range close enough to opening to allow for final electrical connections. Remove shipping base, cardboard, or hardboard from under range.
- Move range into its final location, making sure rear leveling leg slides into anti-tip bracket.

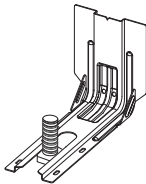

- Move range forward onto shipping base, cardboard, or hardboard to continue installing the range, using the following installation instructions.

## Adjust Leveling Legs

- If range height adjustment is necessary, use a wrench or pliers to loosen the 4 leveling legs.

This may be done with the range on its back or with the range supported on 2 legs after the range has been placed back to a standing position.

**NOTE:** To place range back up into a standing position, put a sheet of cardboard or hardboard in front of range. Using 2 or more people, stand range back up onto the cardboard or hardboard.

## ⚠ WARNING



### Tip Over Hazard

**A child or adult can tip the range and be killed.**

**Install anti-tip bracket to floor or wall per installation instructions.**

**Slide range back so rear range foot is engaged in the slot of the anti-tip bracket.**

**Re-engage anti-tip bracket if range is moved.**

**Do not operate range without anti-tip bracket installed and engaged.**

**Failure to follow these instructions can result in death or serious burns to children and adults.**

- Measure the distance from the top of the counter to the floor.
- Measure the distance from the top of the cooktop to the bottom of the leveling legs. This distance should be the same. If it is not, adjust the leveling legs to the correct height. The leveling legs can be loosened to add up to a maximum of 1" (2.5 cm). A minimum of 3/16" (5 mm) is needed to engage the anti-tip bracket.

**NOTE:** If height adjustment is made when range is standing, tilt the range back to adjust the front legs, and then tilt forward to adjust the rear legs.

- When the range is at the correct height, check that there is adequate clearance under the range for the anti-tip bracket. Before sliding range into its final location, check that the anti-tip bracket will slide under the range and onto the rear leveling leg prior to anti-tip bracket installation.

**NOTE:** If a Trim Kit will be used, the top of the cooktop should be higher than the counter. See the Installation Instructions included with the Trim Kit for the correct height.

## Level Range

1. Place level on the oven bottom, as indicated in one of the two figures below, depending on the size of the level. Check with the level side to side and front to back.

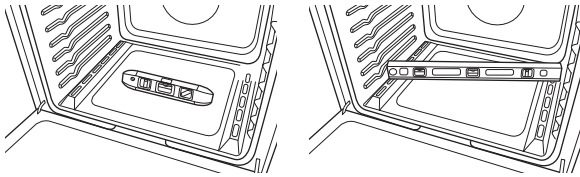

2. If range is not level, use a wrench or pliers to adjust leveling legs up or down until the range is level.

**NOTE:** Range must be level for satisfactory baking performance and best cleaning results using AquaLift® Self-Clean Technology.

## Make Gas Connection

### ⚠ WARNING



#### Explosion Hazard

Use a new CSA International approved gas supply line.

Install a shut-off valve.

Securely tighten all gas connections.

If connected to propane, have a qualified person make sure gas pressure does not exceed 14" (36 cm) water column.

Examples of a qualified person include:

licensed heating personnel,  
authorized gas company personnel, and  
authorized service personnel.

Failure to do so can result in death, explosion, or fire.

This range is factory-set for use with Natural gas. To use this range with propane gas, see the "Gas Conversions" section before connecting this range to the gas supply. Gas conversions from Natural gas to propane gas or from propane gas to Natural gas must be done by a qualified installer.

### Typical Flexible Connection

1. Apply pipe-joint compound made for use with propane gas to the smaller thread ends of the flexible connector adapters. See B and G in the following illustration.
2. Attach one adapter to the gas pressure regulator and the other adapter to the gas shut-off valve. Tighten both adapters, being certain not to move or turn the gas pressure regulator.

3. Use a 15/16" (2.4 cm) combination wrench and an adjustable wrench to attach the flexible connector to the adapters.

**IMPORTANT:** All connections must be wrench-tightened. Do not make connections to the gas regulator too tight. Making the connections too tight may crack the regulator and cause a gas leak. Do not allow the regulator to turn when tightening fittings.

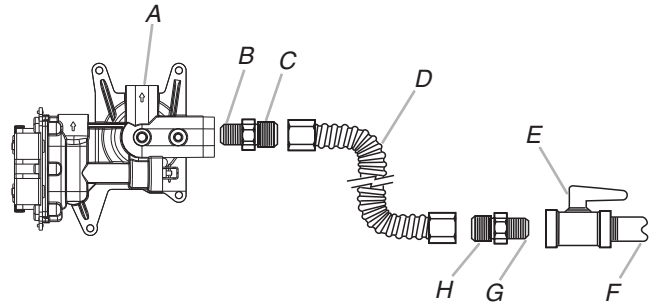

A. Gas pressure regulator

B. Use pipe-joint compound.

C. Adapter (must have 1/2" [1.3 cm] male pipe thread)

D. Flexible connector

E. Manual gas shut-off valve

F. 1/2" (1.3 cm) or 3/4" (1.9 cm) gas pipe

G. Use pipe-joint compound.

H. Adapter

### Complete Connection

1. Check that the gas pressure regulator shut-off valve is in the "on" position.

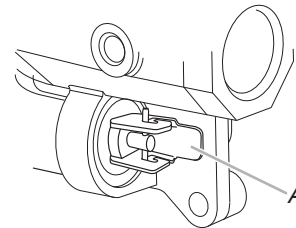

A. Gas pressure regulator shut-off valve shown in the "on" position

2. Open the manual shut-off valve in the gas supply line. The valve is open when the handle is parallel to the gas pipe.

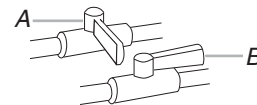

A. Closed valve

B. Open valve

3. Test all connections by brushing on an approved noncorrosive leak-detection solution. If bubbles appear, a leak is indicated. Correct any leak found.

4. Remove cooktop burner caps and bases from package containing parts. Place the burner bases as indicated by the following illustration for your model:

**For Model KSGG700E:**

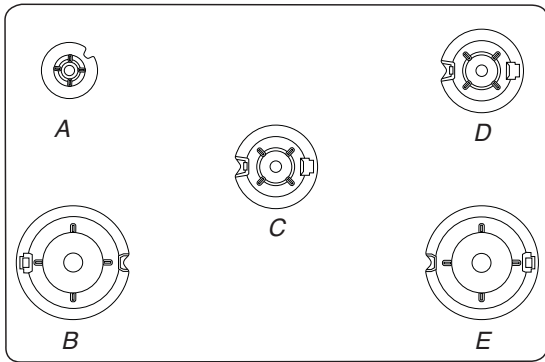

- A. Small (Auxiliary) C. Medium (Semi Rapid) D. Medium (Semi Rapid)  
B. X-Large (Stack) E. Large (Ultra Rapid)

5. Align the gas tube opening in the burner base with the orifice holder on the cooktop and the igniter electrode with the notch in the burner base.

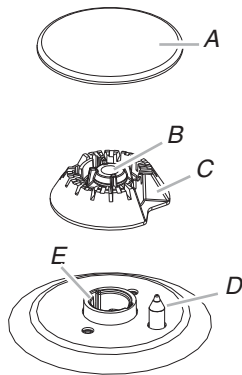

- A. Burner cap D. Igniter electrode  
B. Gas tube opening E. Orifice holder  
C. Burner base

6. Place the burner caps on the appropriate burner bases.

**IMPORTANT:** The bottom of the small and medium caps are different. Do not put the wrong size burner cap on the burner base.

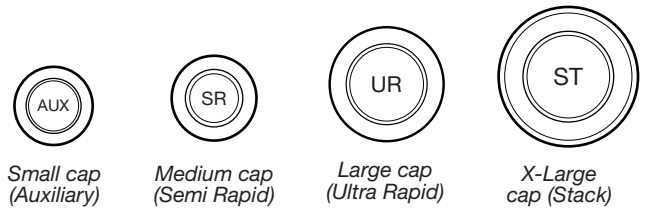

Burner caps should be level when properly positioned. If burner caps are not properly positioned, surface burners will not light. The burner cap should not rock or wobble when properly aligned.



- A. Incorrect  
B. Correct

**⚠ WARNING**



**Electrical Shock Hazard**

**Plug into a grounded 3 prong outlet.**

**Do not remove ground prong.**

**Do not use an adapter.**

**Do not use an extension cord.**

**Failure to follow these instructions can result in death, fire, or electrical shock.**

7. Plug into a grounded 3 prong outlet.

---

## Verify Anti-Tip Bracket Is Installed and Engaged

### On Ranges Equipped with a Premium Storage Drawer:

1. Slide range into final location, making sure rear leveling leg slides into anti-tip bracket.
2. Remove the premium storage drawer. See the "Remove/Replace Drawer" section.
3. Use a flashlight to look underneath the bottom of the range.
4. Visually check that the rear range foot is inserted into the slot of the anti-tip bracket.

### On Ranges Equipped with a Warming Drawer or Baking Drawer:

1. Slide range into final location, making sure rear leveling leg slides into anti-tip bracket. Leave a 1" (2.5 cm) gap between the back of the range and the back wall.
2. Place the outside of your foot against the bottom front of the warming drawer or baking drawer to keep the range from moving, and then grasp the back of the range, as shown.

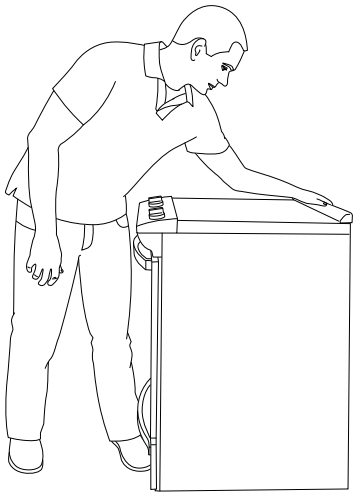

3. Slowly attempt to tilt the range forward. If you encounter immediate resistance, the range foot is engaged in the anti-tip bracket. Go to Step 8.
4. If the rear of the range lifts more than 1/2" (1.3 cm) off the floor without resistance, stop tilting the range and lower it gently back to the floor. The range foot is not engaged in the anti-tip bracket.  
**IMPORTANT:** If there is a snapping or popping sound when lifting the range, the range may not be fully engaged in the bracket. Check to see if there are obstructions keeping the range from sliding to the wall or keeping the range foot from sliding into the bracket. Verify that the bracket is held securely in place by the mounting screws.
5. Slide the range forward, and verify that the anti-tip bracket is securely attached to the floor or wall.
6. Slide range back so the rear range foot is inserted into the slot of the anti-tip bracket.
7. Repeat steps 1 and 2 to ensure that the range foot is engaged in the anti-tip bracket.  
If the rear of the range lifts more than 1/2" (1.3 cm) off the floor without resistance, the anti-tip bracket may not be installed correctly. Do not operate the range without anti-tip bracket installed and engaged. Please reference the "Warranty" section of the User Guide to contact service.
8. Move the range into its final location. Check that the range is level by placing a level on the oven bottom. See the "Level Range" section.

**IMPORTANT:** If the range is moved to adjust the leveling legs, verify that the anti-tip bracket is engaged by repeating steps 1 to 8.

---

## Electronic Ignition System

### Initial Lighting and Gas Flame Adjustments

Cooktop and oven burners use electronic igniters in place of standing pilots. When the cooktop control knob is turned to the "ignite" position, the system creates a spark to light the burner. All cooktop burners will spark, but only the burner with the control knob turned to the "ignite" position will produce a flame. This sparking continues as long as the control knob is turned to the "ignite" position.

When the oven control is turned to the desired setting, sparking occurs and ignites the gas.

---

### Check Operation of Cooktop Burners

#### Standard Surface Burners

Push in and turn each control knob to the "ignite" position.

The flame should light within 4 seconds. The first time a burner is lit, it may take longer than 4 seconds to light because of air in the gas line.

#### If Burners Do Not Light Properly:

- Turn cooktop control knob to the "off" position.
- Check that the range is plugged into a grounded 3 prong outlet. Check that the circuit breaker has not tripped or the household fuse has not blown.
- Check that the gas shut-off valves are set to the open position.
- Check that burner caps are properly positioned on burner bases.

Repeat start-up. If a burner does not light at this point, turn the control knobs to the "off" position and contact your dealer or authorized service company for assistance. Please reference the "Warranty" section of the User Guide to contact service.

If the cooktop "low" burner flame needs to be adjusted for any of the burners, see the "Adjust Flame Height" section.

---

### Check Operation of Oven Bake Burner

1. Press BAKE.
2. Press the Start pad.  
The oven burner should light within 8 seconds. The first time a burner is lit, it may take longer than 8 seconds to light because of air in the gas line.
3. After 2 minutes, open the oven door and check that the oven is warm.

#### If Burner Does Not Light Properly:

- Press the Off pad.
- Check that the range is plugged into a grounded 3 prong outlet. Check that the circuit breaker has not tripped or the household fuse has not blown.
- Check that the gas shut-off valves are set to the open position.

Repeat steps 1 to 3. If the burner does not light at this point, press the off pad and contact your dealer or authorized service company for assistance. Please reference the "Warranty" section of the User Guide to contact service.

If the bake burner flame needs to be adjusted, see the "Adjust Flame Height" section.

Refer to the User Guide for proper operation of the oven controls.

### Check Operation of Oven Broil Burner

1. Close the oven door.
2. Press BROIL.
3. Press the Start pad.  
The oven burner should light within 8 seconds. The first time a burner is lit, it may take longer than 8 seconds to light because of air in the gas line.
4. After 2 minutes, open the oven door and check that the oven is warm.

### If Burner Does Not Light Properly:

- Press the Off pad.
- Check that the range is plugged into a grounded 3 prong outlet. Check that the circuit breaker has not tripped or the household fuse has not blown.
- Check that the gas shut-off valves are set to the open position.

Repeat steps 1 to 3. If the burner does not light at this point, press the Off pad and contact your dealer or authorized service company for assistance. Please reference the "Warranty" section of the User Guide to contact service.

If the broil burner flame needs to be adjusted, see the "Adjust Flame Height" section.

Refer to the User Guide for proper operation of the oven controls.

## Remove/Replace Drawer (on some models)

Remove all items from inside the baking drawer, warming drawer or premium storage drawer, and then allow the range to cool completely before attempting to remove the drawer.

### To Remove:

1. Open the drawer to its fully open position.
2. Using a flat-blade screwdriver, gently loosen the drawer from the glide alignment notch, and then lift up the drawer alignment tab from the glide.

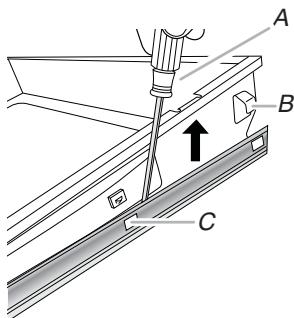

A. Flat-blade screwdriver  
B. Drawer alignment tab  
C. Drawer glide notch

3. Repeat Step 2 on the other side. The drawer is no longer attached to the drawer glides. Using both hands, pick up the drawer to complete the removal.

### To Replace:

1. Align the forward drawer notches with the notches in the drawer glides on both sides. Place the rear alignment tabs into the drawer glides on both sides.

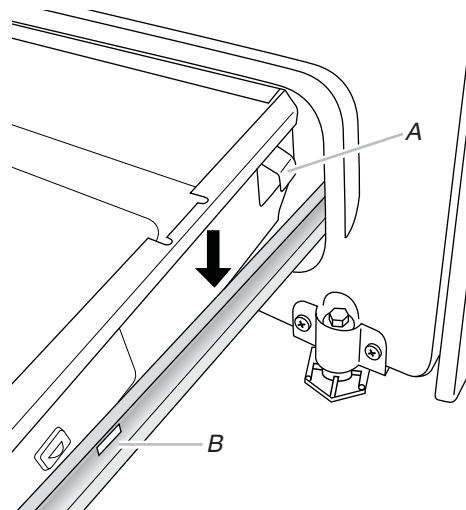

A. Drawer alignment tab  
B. Drawer glide notch

2. Push the drawer in all the way.
3. Gently open and close the drawer to ensure it is seated properly on the glides on both sides.

## Oven Door

For normal range use, it is not suggested to remove the oven door. However, if removal is necessary, make sure the oven is OFF and cool. Then, follow these instructions. The oven door is heavy.

### To Remove:

1. Open oven door all the way.
2. Pinch the hinge latch between two fingers and pull forward. Repeat on other side of oven door.

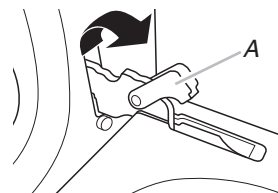

A. Hinge latch

3. Close the oven door as far as it will shut.
4. Lift the oven door while holding both sides. Continue to push the oven door closed and pull it away from the oven door frame.



## To Replace:

1. Insert both hanger arms into the door. Be sure that the hinge notches are engaged in the oven door frame.

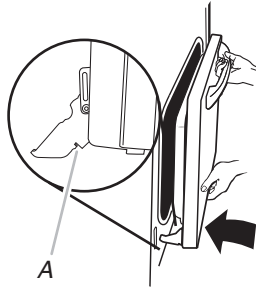

A. Hinge notch

2. Open the oven door.  
The door should be able to open all the way.
3. Move the hinge levers back to the “locked” position. Check that the door is free to open and close and is level while closed. If it is not, repeat the removal and installation procedures.

---

## Complete Installation

1. Check that all parts are now installed. If there is an extra part, go back through the steps to see which step was skipped.
2. Check that you have all of your tools.
3. Check that you have all of the range accessories, especially oven racks. These accessories may be in the range packaging.
4. Dispose of/recycle all packaging materials.
5. Check that the range is level. See the “Level Range” section.
6. Use a mild solution of liquid household cleaner and warm water to remove waxy residue caused by shipping material. Dry thoroughly with a soft cloth. For more information, see the “Range Care” section of the User Guide.

7. Read the User Guide.
8. Turn on surface burners and oven. See the User Guide for specific instructions on range operation.  
**NOTE:** Odors and smoke are normal when the oven is used the first few times.

### If Range Does Not Operate, Check the Following:

- Household fuse is intact and tight, or circuit breaker has not tripped.
  - Gas pressure regulator shut-off valve is in the “open” position.
  - Range is plugged into a grounded 3 prong outlet.
  - Electrical supply is connected.
9. When the range has been ON for 5 minutes, check for heat. If the range is cold, turn off the range and check that the gas supply line shut-off valve is open.
    - If the gas supply line shut-off valve is closed, open it, and then repeat the 5 minute test as outlined above.
    - If the gas supply line shut-off valve is open, close it, and contact a qualified technician.

### If You Need Assistance or Service:

Please reference the “Warranty” section of the User Guide to contact service.

# GAS CONVERSIONS

Gas conversions from Natural gas to propane gas or from propane gas to Natural gas must be done by a qualified installer.

## ⚠️ WARNING



### Explosion Hazard

Use a new CSA International approved gas supply line.

Install a shut-off valve.

Securely tighten all gas connections.

If connected to propane, have a qualified person make sure gas pressure does not exceed 14" (36 cm) water column.

Examples of a qualified person include:

licensed heating personnel,  
authorized gas company personnel, and  
authorized service personnel.

Failure to do so can result in death, explosion, or fire.

## Propane Gas Conversion

## ⚠️ WARNING



### Tip Over Hazard

A child or adult can tip the range and be killed.

Install anti-tip bracket to floor or wall per installation instructions.

Slide range back so rear range foot is engaged in the slot of the anti-tip bracket.

Re-engage anti-tip bracket if range is moved.

Do not operate range without anti-tip bracket installed and engaged.

Failure to follow these instructions can result in death or serious burns to children and adults.

1. Turn the manual shut-off valve to the closed position.

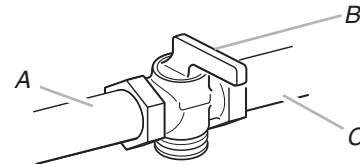

A. Gas supply line

B. Manual shut-off valve "closed" position

C. To range

2. Unplug range or disconnect power.

### To Convert Gas Pressure Regulator (Natural Gas to Propane Gas)

1. Remove the premium storage drawer, warming drawer or baking drawer. See the "Remove/Replace Drawer" section.
2. Locate gas pressure regulator at rear of the drawer compartment.

**NOTE:** On models with a warming drawer or baking drawer, an access cover must be removed to access the gas pressure regulator.

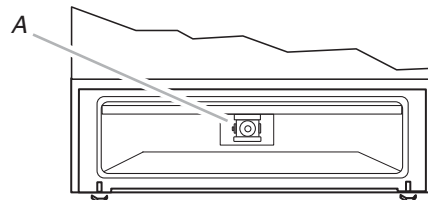

A. Gas pressure regulator

**IMPORTANT:** Do not remove the gas pressure regulator.



- Remove plastic cover from gas pressure regulator cap.
- Turn gas pressure regulator cap counterclockwise with a 5/8" (1.6 cm) combination wrench to remove.

**NOTE:** Do not remove the spring beneath the cap.

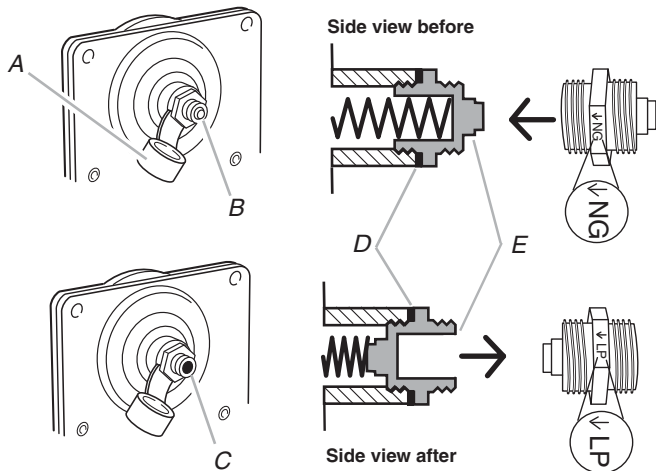

- A. Plastic cover
- B. Gas pressure regulator cap with solid end facing out
- C. Gas pressure regulator cap with hollow end facing out
- D. Washer
- E. Gas pressure regulator cap

- Turn over the gas pressure regulator cap and reinstall on regulator so that the hollow end faces out and the marking "↓LP" is facing the direction shown in the above drawing.
- Replace plastic cover over gas pressure regulator cap.

### To Convert Surface Burners (Natural Gas to Propane Gas)

- Remove burner cap.
- Remove the burner base.

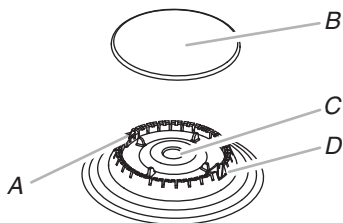

- A. Igniter electrode
- B. Burner cap
- C. Gas tube opening
- D. Burner base

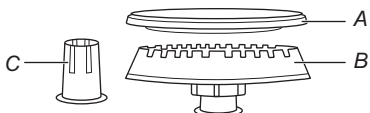

#### X-Large Burner

- A. Burner cap
- B. Burner base
- C. Choke (for use with x-large burner, propane gas only)

- Apply masking tape to the end of a 9/32" (7 mm) nut driver to help hold the gas orifice spud in the nut driver while changing it. Press nut driver down onto the gas orifice spud and remove by turning it counterclockwise and lifting out. Set gas orifice spud aside.

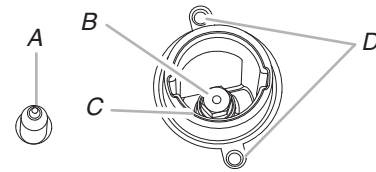

- A. Igniter electrode
- B. Orifice spud
- C. Orifice spud holder
- D. Screws

- Remove the orifice spuds shipped in the literature package in the oven. Gas orifice spuds are stamped with a number and have a groove in the hex area. Replace the Natural gas orifice spud with the correct propane gas orifice spud.

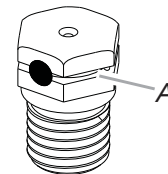

A. Propane groove

Refer to the following chart for correct propane gas orifice spud ratings and to spud holder card for proper placement.

### Propane Gas Orifice Spud Chart for Surface Burners

Placement	Burner Rating/Type	Size (mm)	ID Number
LF (ST)	15,000 BTU	1.08	108AM
	1,450 BTU	0.35	035AM
LR	5,000 BTU	0.64	064AM
RF	14,200 BTU	1.08	108AM
RR	8,000 BTU	0.84	084AM
CTR	8,000 BTU	0.84	084AM

**NOTE:** Refer to the model/serial/rating plate located on the oven frame behind the top left-hand side of the oven door for proper sizing of spuds for each burner location.

- Place Natural gas orifice spuds in the orifice spud bag.
  - IMPORTANT:** Keep the Natural gas orifice spuds in case of reinstallation with Natural gas.
- Replace the burner base.
- Replace burner cap.
- Repeat steps 1 to 7 for the remaining burners.

## To Convert Oven Bake Burner (Natural Gas to Propane Gas)

1. Remove the oven racks and the oven door. See the "Oven Door" section.
2. Remove 2 screws and washers at the rear of the oven bottom.
3. Lift the rear of the oven bottom up and back until the front of the panel is away from the front frame. Remove from oven and set it aside on a covered surface.

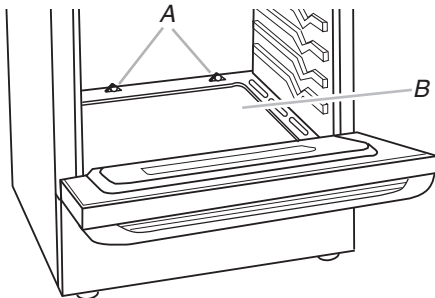

A. Screws  
B. Oven bottom

4. Remove 2 screws from the bake burner.
5. Slide the front of the bake burner to the side to remove tab from front of oven. Lift the back of the bake burner off the oven orifice and set the bake burner aside. Do not disconnect the wire.

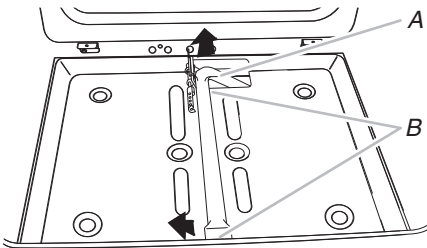

A. Bake burner  
B. Screws

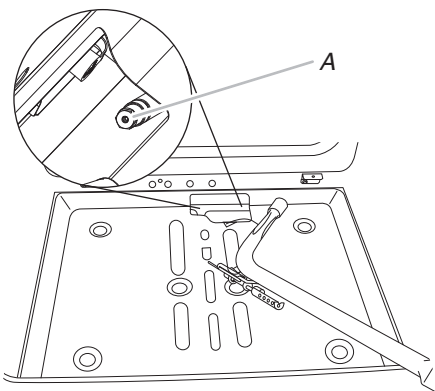

A. Oven orifice

6. Apply masking tape to the end of a 3/8" (1 cm) nut driver to help hold the gas orifice spud in the nut driver while changing it. Press nut driver down onto the gas orifice spud and remove by turning the Natural gas bake burner orifice spud counterclockwise to remove. The spud will be stamped with a "47."
7. Replace the "47" spud with a "56" spud. Install the propane gas bake burner orifice spud, turning it clockwise until snug. **IMPORTANT:** Do not overtighten.

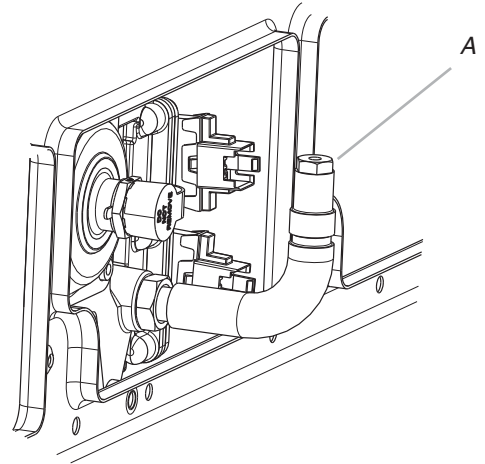

A. Orifice spud

8. Position the back of the bake burner over the oven orifice, and then align the holes for the screws.
9. Reattach the bake burner with 2 screws.
10. Position the front of the oven bottom panel toward the front frame, and then lower the rear of the oven bottom panel into the oven.
11. Reattach the oven bottom panel with 2 screws and 2 washers.

## To Convert Oven Broil Burner (Natural Gas to Propane Gas)

1. Remove the 1 screw from the broil burner.
2. Remove the flame spreader.
3. Remove the broil burner from the broil burner orifice hood. **NOTE:** The broil burner will hang in the back of the oven while you are changing the orifice hood.

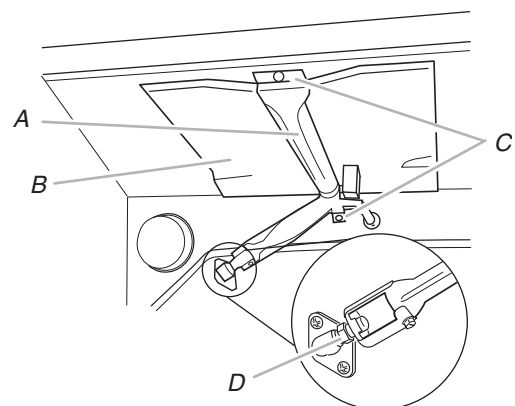

A. Broil burner  
B. Flame spreader  
C. Screws  
D. Orifice hood

- Apply masking tape to the end of a 3/8" (1 cm) nut driver to help hold the gas orifice spud in the nut driver while changing it. Press nut driver down onto the gas orifice spud and remove by turning the Natural gas broil burner orifice hood counterclockwise to remove. The hood will be stamped with a "155."
- Replace the "155" hood with a "100" hood. Install the propane gas broiler burner orifice hood, turning it clockwise until snug.

**IMPORTANT:** Do not overtighten.

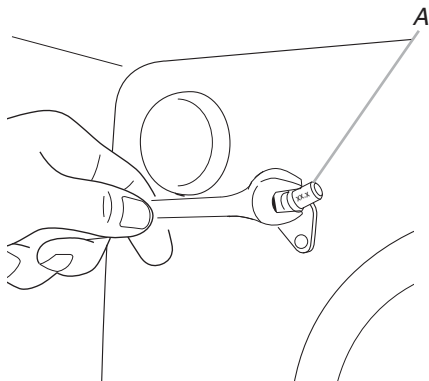

A. Orifice hood

- Place the broil burner on the broil burner orifice hood. Insert the broil burner ceramic igniter in the hole in the rear of the oven.
- Replace the flame spreader with all 4 tabs facing up and the notches toward the rear of the oven.
- Position the broil burner against the top of the oven and attach it with 1 screw.
- Replace storage drawer. See the "Remove/Replace Drawer" section.
- Replace the oven door. See the "Oven Door" section.
- Replace the oven racks.

### Complete Installation (Natural Gas to Propane Gas)

- Refer to the "Make Gas Connection" section for proper connection of the range to the gas supply.
- Refer to the "Electronic Ignition System" section for proper burner ignition and operation.
- Refer to the "Adjust Flame Height" section for burner flame adjustments.

**IMPORTANT:** You may have to adjust the low setting for each cooktop burner.

Checking for proper cooktop flame is very important. The small inner cone should have a very distinct blue flame 1/4" to 1/2" (6.35 mm to 1.3 cm) long. The outer cone is not as distinct as the inner cone. propane gas flames have a slightly yellow tip.

- Refer to "Complete Installation" in the "Installation Instructions" section of this manual to complete this procedure.

**IMPORTANT:** Make sure to save the orifices that have just been replaced in the conversion.

## Natural Gas Conversion

### ⚠ WARNING



#### Tip Over Hazard

**A child or adult can tip the range and be killed.**

**Install anti-tip bracket to floor or wall per installation instructions.**

**Slide range back so rear range foot is engaged in the slot of the anti-tip bracket.**

**Re-engage anti-tip bracket if range is moved.**

**Do not operate range without anti-tip bracket installed and engaged.**

**Failure to follow these instructions can result in death or serious burns to children and adults.**

- Turn the manual shut-off valve to the "closed" position.

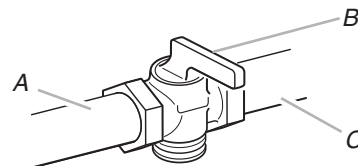

A. Gas supply line

B. Manual shut-off valve "closed" position

C. To range

- Unplug range or disconnect power.

### To Convert Gas Pressure Regulator (Propane Gas to Natural Gas)

- Remove the premium storage drawer, warming drawer or baking drawer. See the "Remove/Replace Drawer" section.
- Locate gas pressure regulator at rear of the drawer compartment.

**NOTE:** On models with a warming drawer or baking drawer, an access cover must be removed to access the gas pressure regulator.

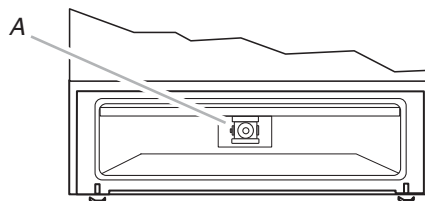

A. Gas pressure regulator

- IMPORTANT:** Do not remove the gas pressure regulator.
- Remove plastic cover from gas pressure regulator cap.

- Turn gas pressure regulator cap counterclockwise with a 5/8" (1.6 cm) combination wrench to remove.

**NOTE:** Do not remove the spring beneath the cap.

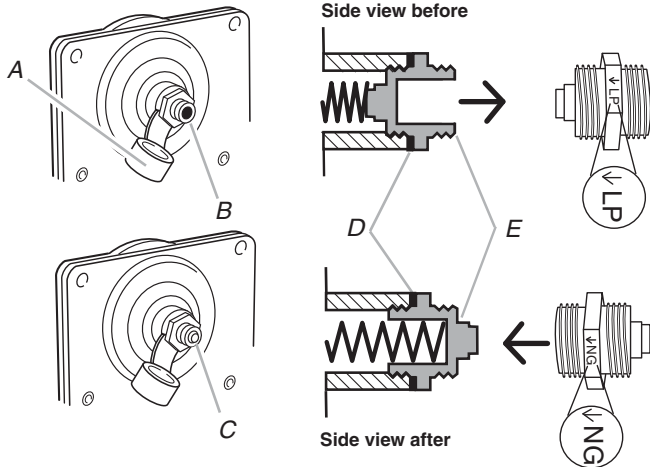

- A. Plastic cover
- B. Gas pressure regulator cap with hollow end facing out
- C. Gas pressure regulator cap with solid end facing out
- D. Washer
- E. Gas pressure regulator cap

- Turn over the gas pressure regulator cap and reinstall on regulator so that the solid end faces out and the marking "↓ NG" is facing the direction shown in the above drawing.
- Replace plastic cover over gas pressure regulator cap.

- Apply masking tape to the end of a 9/32" (7 mm) nut driver to help hold the gas orifice spud in the nut driver while changing it. Press nut driver down onto the gas orifice spud and remove by turning it counterclockwise and lifting out. Set gas orifice spud aside.

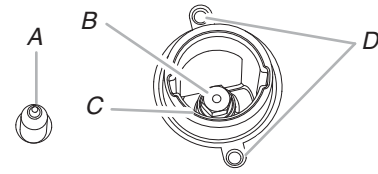

- A. Igniter electrode
- B. Orifice spud
- C. Orifice spud holder
- D. Screws

- Gas orifice spuds are stamped with a number on the side. Replace the propane gas orifice spud with the correct Natural gas orifice spud.

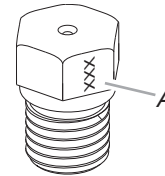

A. Stamped number

Refer to the following chart for the correct Natural gas orifice spud placement.

#### Natural Gas Orifice Spud Chart

Burner Rating	Size (mm)	ID Number
19,000 BTU (ST)	1.96	196AM
17,000 BTU (ST)	1.84	184AM
17,000 BTU	1.96	196AM
15,000 BTU	1.75	175AM
9,200 BTU	1.35	135AM
8,000 BTU	1.25	125AM
5,000 BTU	1.00	100AM
1,450 BTU	0.53	053AM

**NOTE:** Refer to the model/serial/rating plate located on the oven frame behind the top right-hand side of the oven door for proper sizing of spuds for each burner location.

- Place propane gas orifice spuds in the orifice spud bag. **IMPORTANT:** Keep the propane gas orifice spuds in case of reinstallation with propane gas.
- Replace the burner base.
- Replace burner cap.
- Repeat steps 1 to 7 for the remaining burners.

#### To Convert Surface Burners (Propane Gas to Natural Gas)

- Remove burner cap.
- Remove the burner base.

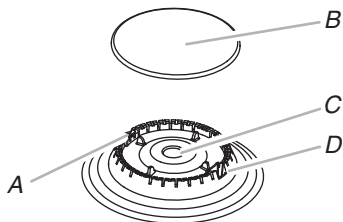

- A. Igniter electrode
- B. Burner cap
- C. Gas tube opening
- D. Burner base

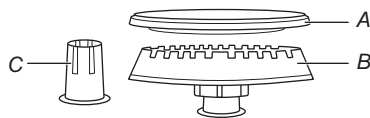

#### X-Large Burner

- A. Burner cap
- B. Burner base
- C. Choke (for use with x-large burner, propane gas only)

## To Convert Oven Bake Burner (Propane Gas to Natural Gas)

1. Remove the oven racks and the oven door. See the "Oven Door" section.
2. Remove 2 screws and washers at the rear of the oven bottom.
3. Lift the rear of the oven bottom up and back until the front of the panel is away from the front frame. Remove from oven and set it aside on a covered surface.

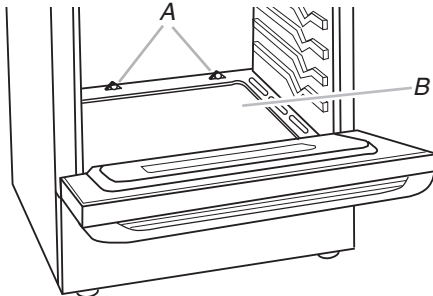

A. Screws  
B. Oven bottom

4. Remove 2 screws from the bake burner.
5. Slide the front of the bake burner to the side to remove tab from front of oven. Lift the back of the bake burner off the oven orifice, and set the bake burner aside. Do not disconnect the wire.

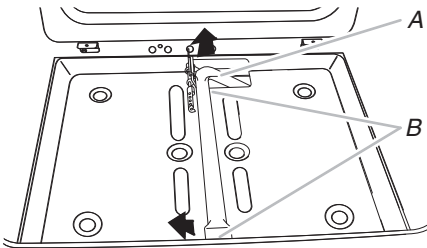

A. Bake burner  
B. Screws

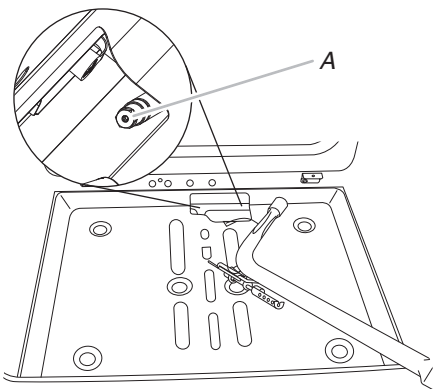

A. Oven orifice

6. Apply masking tape to the end of a 3/8" (1 cm) nut driver to help hold the gas orifice spud in the nut driver while changing it. Press nut driver down onto the gas orifice spud and remove by turning the propane gas bake burner orifice spud counterclockwise to remove. The spud will be stamped with a "56."

7. Replace the "56" spud with a "47" spud. Install the Natural gas bake burner orifice spud, turning it clockwise until snug. **IMPORTANT:** Do not overtighten.

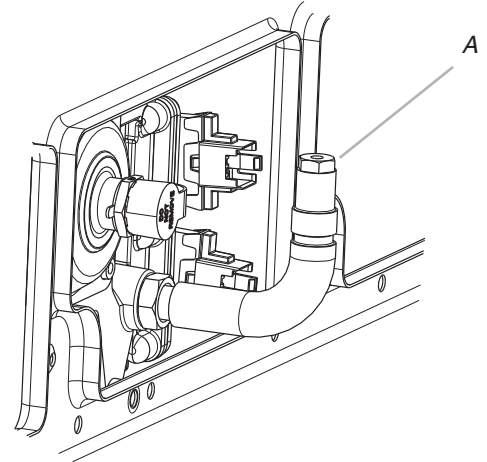

A. Orifice spud

8. Position the back of the bake burner over the oven orifice, and then align the holes for the screws.
9. Reattach the bake burner with 2 screws.
10. Position the front of the oven bottom panel toward the front frame, and then lower the rear of the oven bottom panel into the oven.
11. Reattach the oven bottom panel with 2 screws and 2 washers.

## To Convert Oven Broil Burner (Propane Gas to Natural Gas) (on some models)

1. Remove 1 screw from the broil burner.
2. Remove the flame spreader.
3. Remove the broil burner from the broil burner orifice hood. **NOTE:** The broil burner will hang in the back of the oven while you are changing the orifice hood.

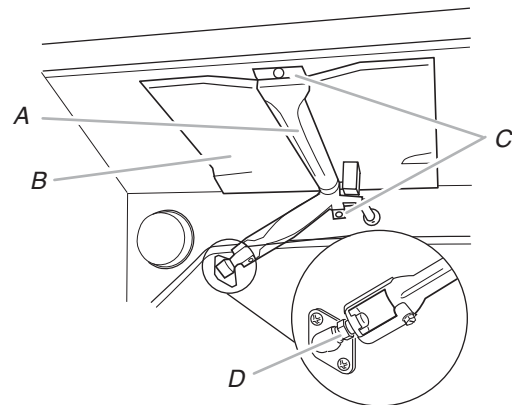

A. Broil burner  
B. Flame spreader  
C. Screws  
D. Orifice hood

4. Apply masking tape to the end of a 3/8" (1 cm) nut driver to help hold the gas orifice spud in the nut driver while changing it. Press nut driver down onto the gas orifice spud and remove by turning the propane gas broil burner orifice hood counterclockwise to remove. The hood will be stamped with a "100."

- Replace the “100” hood with a “155” hood. Install the Natural gas broiler burner orifice hood, turning it clockwise until snug. **IMPORTANT:** Do not overtighten.

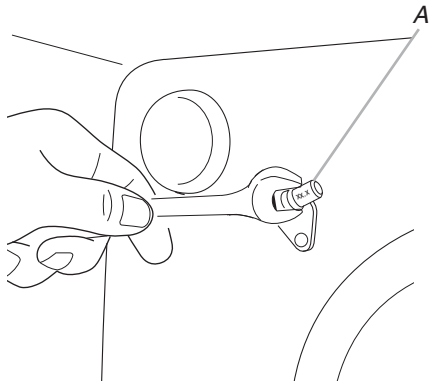

A. Orifice hood

- Place the broil burner on the broil burner orifice hood. Insert the broil burner ceramic igniter in the hole in the rear of the oven.
- Replace the flame spreader with all 4 tabs facing up and the notches toward the rear of the oven.
- Position the broil burner against the top of the oven and attach it with 1 screw.
- Replace the storage drawer. See the “Remove/Replace Drawer” section.
- Replace the oven door. See the “Oven Door” section.
- Replace the oven racks.

### Complete Installation (Propane Gas to Natural Gas)

- Refer to the “Make Gas Connection” section for proper connection of the range to the gas supply.
- Refer to the “Electronic Ignition System” section for proper burner ignition and operation.
- Refer to the “Adjust Flame Height” section for burner flame adjustments.

**IMPORTANT:** You may have to adjust the low setting for each cooktop burner.

Checking for proper cooktop, bake and broil burner flame is very important. Natural gas flames do not have yellow tips.

- Refer to “Complete Installation” in the “Installation Instructions” section of this manual to complete this procedure.

**IMPORTANT:** Make sure to save the orifices that have just been replaced in the conversion.

## Adjust Flame Height

### Adjust Surface Burner Flame

Adjust the height of top burner flames. The cooktop “low” burner flame should be a steady blue flame approximately ¼” (6.35 mm) high. propane gas flames have a slightly yellow tip.

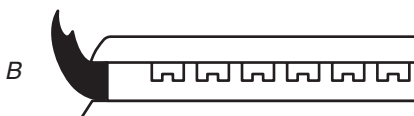
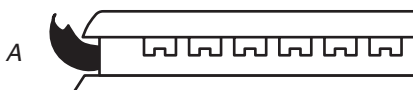

A. Low flame  
B. High flame

### To Adjust Standard Burner:

The flame can be adjusted using the adjustment screw in the center of the valve stem. The valve stem is located directly underneath the control knob.

#### If the “Low” Flame Needs to Be Adjusted:

- Light 1 burner and turn to lowest setting.
- Remove the control knob.

Hold the knob stem with a pair of pliers. Use a small flat blade screwdriver to turn the screw located in the center of the control knob stem until the flame is the proper size. Turning the screw clockwise will increase the flame size and counterclockwise will decrease the flame size.

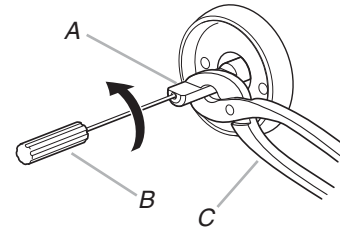

A. Control knob stem  
B. Screwdriver  
C. Pliers

- Replace the control knob.
- Test the flame by turning the control from the low position to the high position, checking the flame at each setting.
- Repeat the previous steps for each burner.

#### To Adjust Double Burner (On Some Models):

- Light burner and turn to lowest setting where both inner and outer burners are lit.
- Remove the control knob.
- Insert a 1/8” (3 mm) flat-blade screwdriver into the adjustment locations shown in the following illustration and engage the slotted screw. Turn the screw until the flame is the proper size. Turning the screw clockwise will increase the flame size and turning the screw counterclockwise will decrease the flame size.

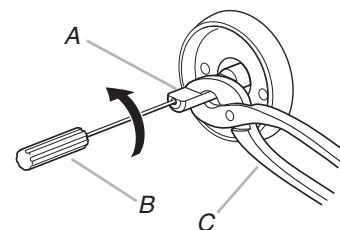

A. Control knob stem  
B. Screwdriver  
C. Pliers

- Replace the control knob.
- Test the flame by turning the control from the low position to the high position, checking the flame at each setting.

### Check Operation of Oven Bake Burner

Refer to the User Guide for proper operation of the oven controls.

## Adjust Oven Bake Burner Flame (If Needed)

1. Remove the premium storage drawer, warming drawer or baking drawer (see the "Remove/Replace Drawer" section).
2. Locate gas pressure regulator at rear of the drawer compartment.

**NOTE:** On models with a warming drawer or baking drawer, an access cover must be removed to access the gas pressure regulator.

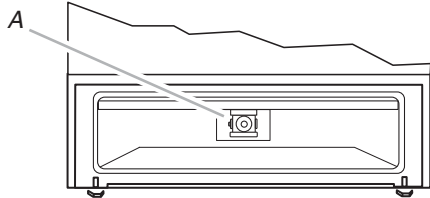

A. Gas pressure regulator

**IMPORTANT:** Do not remove the gas pressure regulator.

3. Check the oven bake burner for proper flame.
  - a. Remove the oven racks.
  - b. To remove the oven bottom: Remove 2 screws at the rear of the oven bottom. Lift the rear of the oven bottom up and back until the front of the panel is away from the front frame. Remove from oven and place on a covered surface.

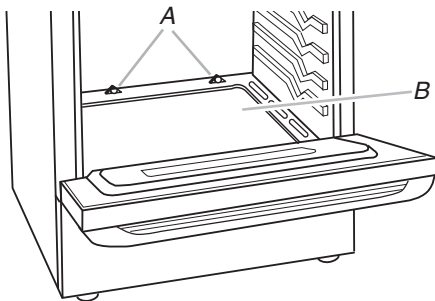

A. Screws  
B. Oven bottom

- c. Press BAKE.
- d. Press the Start pad.

The oven bake burner should light within 8 seconds. Under certain conditions, it may take the burner up to 50 to 60 seconds to light.

Electronic igniters are used to light the bake and broil burners.

This flame should have a 1/2" (1.3 cm) long inner cone of bluish-green with an outer mantle of dark blue and should be clean and soft in character. No yellow tips, blowing, or lifting of flame should occur.

4. If the oven bake flame needs to be adjusted, locate the air shutter near the center rear of the drawer cavity behind the access panel. Loosen the locking screw and rotate the air shutter until the proper flame appears. Tighten locking screw.

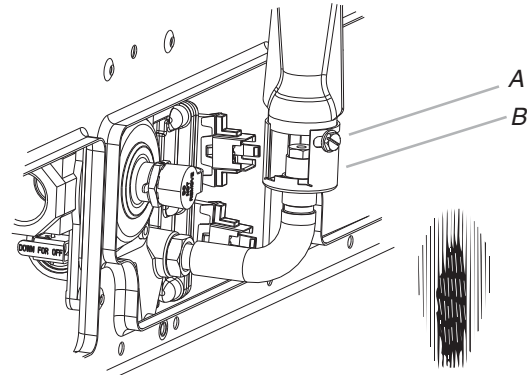

A. Locking screw  
B. Air shutter

5. Push the Off pad when finished.
6. Reinstall the oven bottom and the storage drawer (see the "Remove/Replace Drawer" section).

## Adjust Oven Broil Burner Flame (If Needed)

Press BROIL, and then press the start pad. Look through the oven window to check broil burner for proper flame. This flame should have a 1/2" (1.3 cm) long inner cone of bluish-green with an outer mantle of dark blue and should be clean and soft in character. No yellow tips, blowing, or lifting of flame should be present.

**If Flame Needs to be Adjusted:**

1. Press the Off pad. Let the oven cool.
2. Loosen the lock screw on the air shutter located at the rear of the broil burner.
3. Adjust the air shutter as needed.
4. Tighten lock screw.

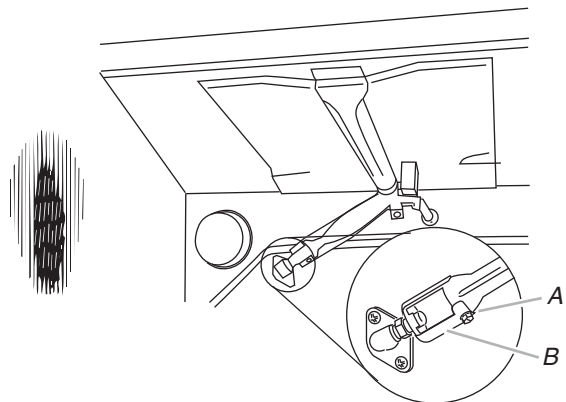

A. Lock screw  
B. Air shutter

5. Close the oven door. Press BROIL, and then press the Start pad. Look through the oven window to check broil burner for proper flame. If flame needs to be adjusted, repeat steps 1 to 5.

