



EN WINE CABINET
FR ARMOIRE À VIN
ES GABINETE DEL VINO

USE AND CARE GUIDE
GUIDE D'UTILISATION ET D'ENTRETIEN
GUIA DE USO Y CUIDADO

VINTEC

2 Finding Information

Please Read and Save This Guide

Thank you for choosing Vintec, the new premium brand in home appliances. This Use & Care Guide is part of our commitment to customer satisfaction and product quality throughout the service life of your new Wine Cabinet.

We view your purchase as the beginning of a relationship. To ensure our ability to continue serving you, please use this page to record key product information.



IMPORTANT

PLEASE READ all instructions completely before attempting to install or operate the unit.

All Wine Cabinets require a connection to an electrical power source. Improper hook-up can result in a safety hazard and potential damage to the product or contents! Proper installation, in accordance with the manufacturer's specifications and all local codes, is the sole responsibility of the consumer. The manufacturer is not responsible for any installation expenses or damages incurred due to improper installation. If you are unsure of your ability to safely connect electric power to the unit, consult a licensed and insured professional to perform all electrical work.

Once you have your unit installed, we suggest you keep this manual in a safe place for future reference. Should any problems occur, refer to the "Troubleshooting" section of this manual. This information will help you quickly identify a problem and get it remedied. In the event you require assistance, please contact the dealer where you purchased your unit.

Make a Record for Quick Reference

Whenever you call to request information or service, you will need to know your model number and serial number. You can find this information on the serial plate located on the lower right-hand side of your unit below the bottom shelf.



NOTE

Registering your product with Vintec enhances our ability to serve you. You can register online at www.vintecclub.com.

Product Registration

The package containing this manual also includes your product registration information. Warranty coverage begins at the time your Vintec Wine Cabinet was purchased.

Please record the purchase date of your Vintec unit and your dealer's name, address and telephone number.

Purchase Date

Vintec Model Number

Vintec Serial Number

Dealer Name

Dealer Address

Dealer Telephone

Keep this manual and the sales receipt together in a safe place for further reference.

Questions?

For toll-free telephone support in the U.S. and Canada: 1-800-325-1371.

For online support and Internet product information: www.vintec.com

Table of Contents

Finding Information	2
Important Safety Information.....	4
Features	7
Installation	8
Controls and Settings	11
Storage Features	16
Care and Cleaning.....	18
Troubleshooting.....	19
Limited Warranty	21

4 Important Safety Information

Important Safety Instructions

Safety Precautions

Do not attempt to install or operate your unit until you have read the safety precautions in this manual. Safety items throughout this manual are labeled with a Danger, Warning or Caution based on the risk type.

Definitions

 This is the safety alert symbol. It is used to alert you to potential personal injury hazards. Obey all safety messages that follow this symbol to avoid possible injury or death.



DANGER

DANGER indicates an imminently hazardous situation which, if not avoided, will result in death or serious injury.



WARNING

WARNING indicates a potentially hazardous situation which, if not avoided, could result in death or serious injury.



CAUTION

CAUTION indicates a potentially hazardous situation which, if not avoided, may result in minor or moderate injury.



IMPORTANT

Indicates installation, operation, or maintenance information which is important but not hazard-related.

General Precautions



WARNING

RISK OF CHILD ENTRAPMENT. Before you throw away your old appliance, take off the doors and leave shelves in place so that children may not easily climb inside.



WARNING

- Never attempt to repair or perform maintenance on the unit until the electricity has been disconnected.
- Altering, cutting of power cord, removal of power cord, removal of power plug, or direct wiring can cause serious injury, fire and/or loss of property and/or life and will void the warranty.
- Do not lift unit by door handle.



CAUTION

- Use care when moving the unit. Some edges are sharp and may cause personal injury. Wear gloves when moving or repositioning the unit.
- Never install the unit behind closed doors. Be sure front grille is free of obstruction. Obstructing free air flow can cause the unit to malfunction, and may void the warranty.
- Allow unit temperature to stabilize for 24 hours before use.



CAUTION

Use only genuine Vintec replacement parts. Imitation parts can damage the unit and may void the warranty.



WARNING

WARNING! CALIFORNIA RESIDENTS
Cancer and Reproductive Harm
www.P65Warnings.ca.gov



DANGER



DANGER Risk of fire or explosion. Flammable refrigerant used. Do not use mechanical devices to defrost refrigerator. Do not puncture refrigerant tubing.

DANGER Risk of fire or explosion. Flammable refrigerant used. To be repaired only by trained service personnel. Do not puncture refrigerant tubing.



CAUTION



CAUTION Risk of fire or explosion. Flammable refrigerant used. Consult repair manual/owner's guide before attempting to service this product. All safety precautions must be followed.

CAUTION Risk of fire or explosion. Dispose of property in accordance with federal or local regulations. Flammable refrigerant used.

CAUTION Risk of fire or explosion due to puncture of refrigerant tubing. Follow handling instructions carefully. Flammable refrigerant used.



IMPORTANT

This Wine Cabinet is designed to conserve exclusively wine. Do not place food inside.

Child Safety

- This appliance is not intended for use by persons (including children) with reduced physical, sensory or mental capabilities, or lack of experience and knowledge, unless they have been given supervision or instruction concerning use of the appliance by a person responsible for their safety.
- Destroy carton, plastic bags, and any exterior wrapping material immediately after the Wine Cabinet is unpacked. Children should never use these items to play. Cartons covered with rugs, bedspreads, plastic sheets or stretch wrap may

become airtight chambers, and can quickly cause suffocation.

- Remove all staples from the carton. Staples can cause severe cuts, and destroy finishes if they come in contact with other appliances or furniture.
- Always keep the keys in a separate place and out of reach of children.
- An empty, discarded Wine Cabinet is a very dangerous attraction to children.
- Remove the door(s) of any appliance that is not in use, even if it is being discarded.

Proper Disposal of your Wine Cabinet

Risk of child entrapment

Child entrapment and suffocation are not problems of the past. Junked or abandoned Wine Cabinets are still dangerous – even if they will sit for “just a few days”. If you are getting rid of your old unit, please follow the instructions below to help prevent accidents.

We strongly encourage responsible appliance recycling/disposal methods. Check with your utility company or visit www.energystar.gov/recycle for more information on recycling your old Wine Cabinet.

Before you throw away your old Wine Cabinet:

- Remove doors.
- Leave shelves in place so children may not easily climb inside.
- Have refrigerant removed by a qualified service technician.

6 Important Safety Information

Electrical Information

- The Wine Cabinet must be plugged into its own dedicated 115 Volt, 60 Hz., 15 Amp, AC only electrical outlet. The power cord of the appliance is equipped with a three-prong grounding plug for your protection against electrical shock hazards. It must be plugged directly into a properly grounded three prong receptacle. The receptacle must be installed in accordance with local codes and ordinances. Consult a qualified electrician. Avoid connecting refrigerator to a Ground Fault Interruptor (GFI) circuit. Do not use an extension cord or adapter plug.
- If the power cord is damaged, it should be replaced by an authorized service technician to prevent any risk.
- Never unplug the Wine Cabinet by pulling on the power cord. Always grip the plug firmly, and pull straight out from the receptacle to prevent damaging the power cord.
- Unplug the Wine Cabinet before cleaning and before replacing a light bulb to avoid electrical shock.
- Performance may be affected if the voltage varies by 10% or more. Operating the Wine Cabinet with insufficient power can damage the compressor. Such damage is not covered under your warranty.
- Do not plug the unit into an electrical outlet controlled by a wall switch or pull cord to prevent the Wine Cabinet from being turned off accidentally.
- Do not use your Wine Cabinet outdoors. Do not expose it to atmospheric agents (humidity, moist, extreme temperatures etc.).

Grounding type wall receptacle

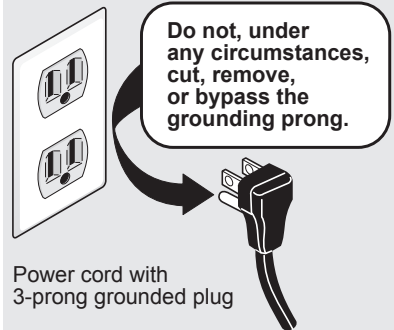

This appliance is intended to be used in household and similar applications such as:

- Staff kitchen areas in shops, offices and other working environments
- Farm houses and by clients in hotels, motels and other residential type environments
- Bed and breakfast type environments
- Catering and similar non-retail applications
- The appliance shall not be exposed to rain

Wine Cabinet

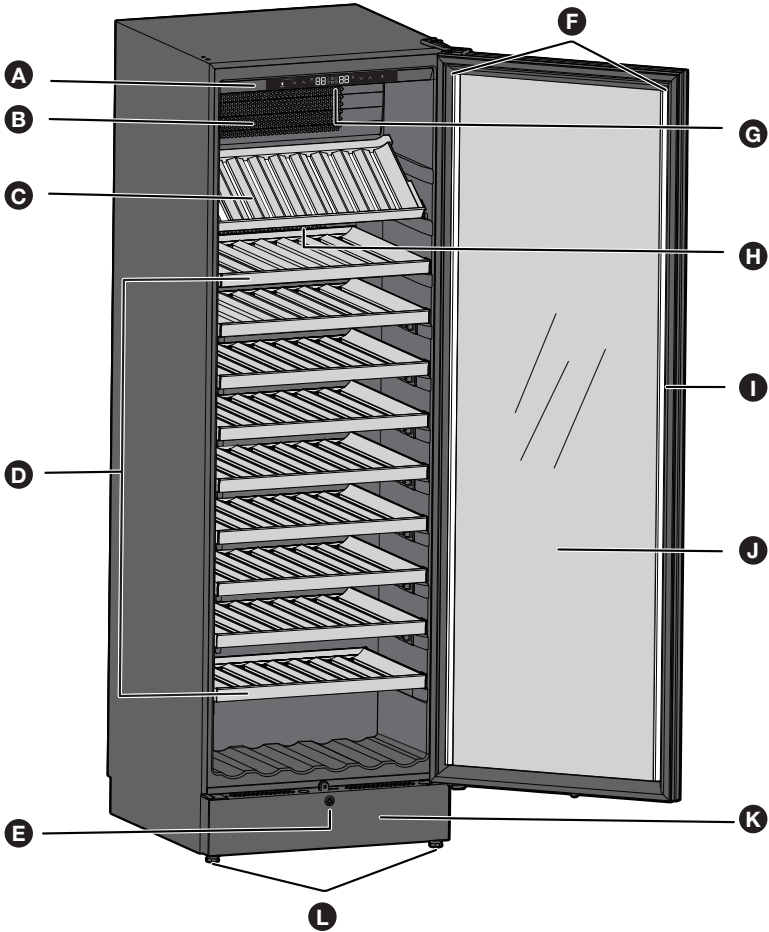

A	Control Panel
B	Fan
C	Removable Shelf
D	Fixed Shelves
E	Lock
F	Lighting

G	Lighting
H	Air Filter
I	Gasket
J	Door
K	Toe Grille
L	Adjustable Feet

8 Installation

Installation of Your Wine Cabinet

Your Vintec Wine Cabinet has been designed for either free-standing or slot-in installation. In either case, the front grille must NOT be obstructed.

- This appliance is designed to be for free standing installation or slot-in (fully recessed). (Refer to sticker located on the back of this appliance.)
- This appliance is intended to be used exclusively for the storage of wine.
- Place your Wine Cabinet on a floor that is strong enough to support it when it is fully loaded. To level your Wine Cabinet, adjust the front leveling legs at the bottom of the unit.
- This appliance uses flammable refrigerant. So never damage the cooling pipe work during the transportation.
- Locate the Wine Cabinet away from direct sunlight and sources of heat (stove, heater, radiator, etc.). Direct sunlight may affect the acrylic coating and heat sources may increase electrical consumption. Extreme cold ambient temperatures may also cause the unit not to perform properly.
- Avoid locating the unit in moist areas.
- Plug the Wine Cabinet into an exclusive, properly installed, grounded wall outlet. Do not under any circumstances cut or remove the third (ground) prong from the power cord. Any questions concerning power and/or grounding should be directed toward a certified electrician or an Authorized Products Service Center.



NOTE

To ease unit installation and removal, it is recommended that the cabinet rough opening dimensions be increased by at least the given dimensions for your unit:

Top	2 inches (50mm)
Back	1.18 inches (10mm)
Sides	.39 inches (30mm)

Before Using Your Wine Cabinet

- Remove the exterior and interior packing.
- Before connecting the Wine Cabinet to the power source, let it stand upright for approximately 2 hours. This will reduce the possibility of a malfunction in the cooling system from handling during transportation.
- Clean the interior surface with lukewarm water using a soft cloth.

Using your Wine Cabinet

- Store wine in sealed bottles.
- Do not overload the cabinet.
- Do not open the door unless necessary.
- Do not cover shelves with aluminum foil or any other shelf material which may prevent air circulation.
- Do not use in a garage.
- Do not use outdoors.

Ambient Temperature

The recommended ambient temperature range for optimal operation is 64-100F (+18C to +38C).



IMPORTANT

Not intended for outdoor/garage environment.

Installing the Anti-Tip Bracket



CAUTION

You must use an anti-tip bracket installed as per these instructions. If the Wine Cabinet is removed from its location for any reason, make sure that the bracket is properly engaged when you push the Wine Cabinet back into the original location. If the bracket is not properly engaged, there is a risk of the Wine Cabinet tipping over, causing property or personal injury if you or a child stands, sits, or leans on an open shelf.



CAUTION

Any finished flooring should be protected with appropriate material to avoid damage when moving the unit.



WARNING

- ALL UNITS CAN TIP
- INJURY COULD RESULT
- INSTALL ANTI-TIP BRACKET PACKED WITH UNIT
- SEE INSTRUCTIONS



NOTE

While performing installation described in this section, gloves AND safety glasses, or goggles should be worn.



WARNING

This appliance may tip when shelves are extended, causing damage or injury. If this appliance is used in a FREE STANDING application, the anti-tip bracket must be installed following these instructions!



IMPORTANT

Determine the final location of the appliance before attempting to install the bracket.

It is recommended to install the anti-tip device to avoid the unit from tipping over. The anti-tip device must be fixed/screwed to the wall allowing the wine cabinet to be pushed into position.

1. Choose the installation location.
2. Place the bracket on the floor against the wall and use 2 wood screws (not provided) (size D6 with minimum length of 20 mm) to secure the bracket to the wall. Ensure at least one screw is secured into a stud.

10 Installation

Installing the Wine Cabinet

Your Vintec Wine Cabinet has been designed for either free-standing or slot-in installation. When slot-in, the unit requires additional space:

Top	2 inches (50mm)
Back	1.18 inches (10mm)
Sides	.39 inches (30mm)

In either case, the front grille must **NOT** be obstructed.

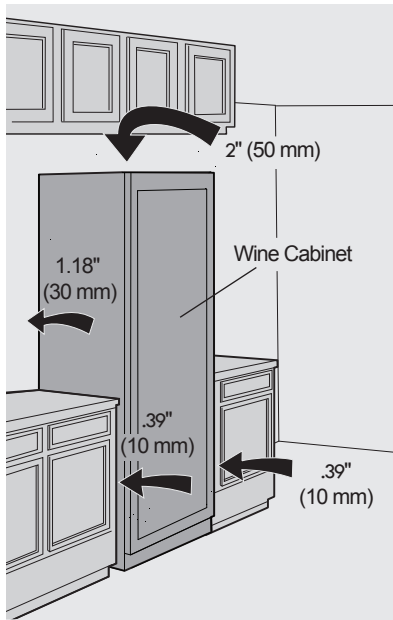

Leveling the Unit

Position the unit on a flat, level surface capable of supporting the entire weight of the unit when full.

Leveling Legs

Adjustable legs at the front corners of the appliance should be set so the unit is firmly positioned on the floor and level from side to side and front to back. The overall height of your Vintec appliance may be adjusted between the minimum, 6' (1850 mm), by turning the leveling leg in and the maximum, 6' ¼" (1913 mm), by turning the leveling leg out.

To adjust the leveling legs, place the appliance on a solid surface and protect the floor beneath the legs to avoid scratching the floor. With the assistance of another person, lean the appliance back to access the front leveling legs. Raise or lower the legs to the required dimension by turning the legs. On a level surface check the appliance for levelness and adjust accordingly.

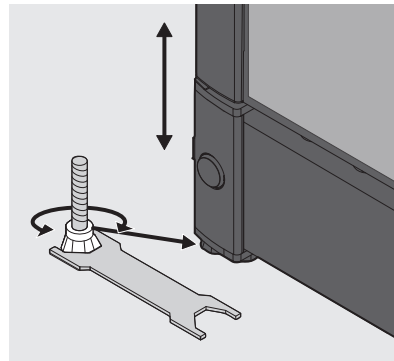

Wine Cabinet Display



Power On/Off



Simultaneously press and hold the Mode button and the increase button for 5 seconds to turn the unit power off or on. When the power is turned back on, the display will show the previous temperature settings.

Upper Temperature Set



Press to decrease/increase the set temperature. Only the set temperature will be shown.

NOTE

Set temperature is shown while the temperature is being changed. Once complete, current temperature will show on display.

Lower Temperature Set



Press to decrease/increase the set temperature. Only the set temperature will be shown.

NOTE

Set temperature is shown while the temperature is being changed. Once complete, current temperature will show on display.

Mode Selection



Press Mode button to change between Single Temp, Multi-Temp, and Cellaring modes.



If the mode is changed to Single Temp, both temperature displays blink and change to 64 °F for 5 seconds. After 5 seconds, the displays change to show current temperatures. In Single Temp Mode, both temperature controls will work in sync so that one temperature is consistent throughout the cabinet.



If the mode is changed to Multi-Temp, the temperature displays blink and change to 64 °F for Upper Temp setting and 46 °F for Lower Temp setting. After 5 seconds, the displays stop blinking and show the current temperature. In Multi-Temp Mode, each temperature control can be adjusted independently (68 °F max Upper Temp setting and 41 °F min Lower Temp setting). There will be a vertical temperature gradient between the two set temperatures from top to bottom allowing you to store all your wine varieties at perfect serving temperatures. See "Multi-Temp" section of this manual.



If the mode is changed to Cellaring, Upper and Lower temperature displays blink "CE" and "CE". After 5 seconds, the displays stop blinking and keep showing "CE" until the Cellaring mode is deactivated.

In Cellaring mode, the temperature is fixed at 54 °F and cannot be changed. This is the optimal temperature for longer term storage of your wine.

12 Controls and Settings

Multi-Temp

Multi-Temp provides flexibility to store all your varietals at a perfect serving temperature. In Multi-Temp mode, the cabinet creates a vertical temperature gradient, allowing you to arrange wines from top-to-bottom at the appropriate serving temperatures for each bottle in your collection. Refer to the diagrams for suggested ranges and to understand how the Multi-Temp distributes the temperature gradient based on settings.

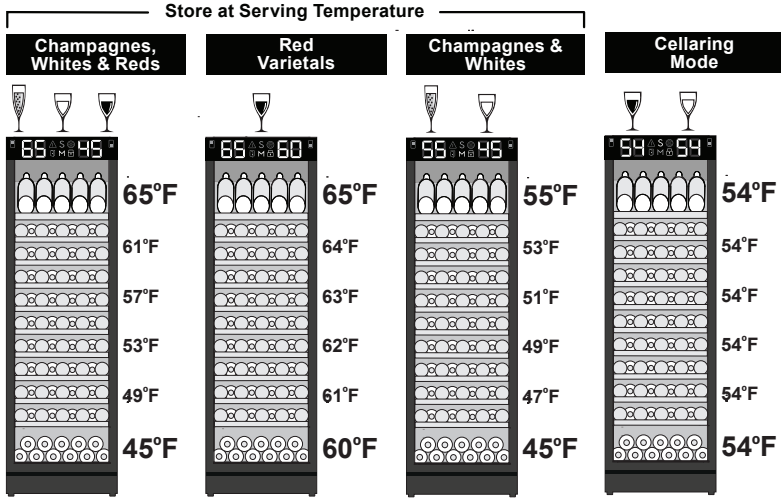

Lights On/Off

Press once to toggle the lights ON/OFF.



Lights Settings Menu

Press and hold for 3 seconds to enter/exit Lights Settings Menu. Both temperature displays blink and show a specific code. Any alert turns off temporarily.



Press ∇ / \blacktriangle to change the Light Mode.

Mode	Door Open	Door Closed	Description
1A			Bright when open. Dim when closed
2A			Bright when open. Off when closed.
3A			Always On.
4A			Dim when open. Bright when closed.

Lights Behavior



Temperature display shows the light setting code:

Lights Dim Level

Bottom temperature display shows the light setting code.

Press \vee / \wedge to change the Dim Level.

1L: Lowest level / least bright (default)

2L:...

3L: Highest level / most bright



Child Lock

Press and hold Mode button for 3 seconds to activate/deactivate child lock.



Child lock indicator changes to the UI until disabled.

- Alerts will not be displayed until the Sabbath Mode is deactivated, except by the High/Low Temperature alerts.

Sabbath Mode exception:



The High/Low Temperature alerts will be displayed in case of high or low temperature inside the appliance. The alert icon turns On, but will not blink, and it will remain until the Sabbath Mode is deactivated. An audio alarm will sound and automatically turn off after 10 minutes.



When Sabbath Mode is deactivated, temperature displays will show the current temperatures.

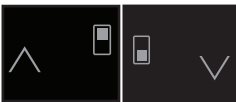

Sabbath Mode

Simultaneously press and hold the increase and decrease buttons for 5

seconds to activate/deactivate Sabbath mode.

When activated, Lower and Upper temperature displays show "Sb" and "On" or "Sb" until deactivated. In this state:

- Any button command is disabled apart from the increase top temperature set and decrease bottom temperature set combination command to deactivate the Sabbath mode.
- All lights are turned Off - apart from "Sb" and "On".
- All sounds are muted except the audio alarm from High/Low Temperature alerts.
- Opening or closing the door will not turn on or off any lights, digital readouts, solenoids, fans, valves, compressor, icons, tones, or alarms.

°C/°F set

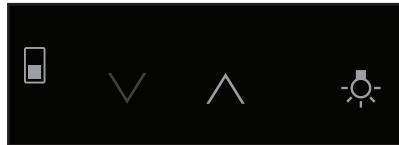

Simultaneously press and hold the increase lower temperature set and light buttons for 5 seconds to toggle the temperature units between °F and °C.



Reset Filter Alert

After 6 months, the filter alert icon turns On.

Simultaneously press and hold the Mode and decrease buttons for 5 seconds to reset the filter change alert.

After reset, the icon turns Off and the count is reset.

14 Controls and Settings



Reset to Factory Settings

Simultaneously press and hold Mode and Upper Temp Set “^” buttons for 5 seconds to reset wine cabinet to factory settings.



Demo Mode

Simultaneously press and hold the Mode and Light buttons for 10 seconds to activate/deactivate Demo mode.



When activated, Upper and Lower temperature displays blink “dE” and “On” respectively for 5 seconds.

Any alert turns off temporarily.

Every 5 minutes after Demo mode is activated, Lower and Upper temperature displays blink “dE” and “On” for 5 seconds.



When deactivated, Lower and Upper temperature displays blink “dE” and “OF” respectively for 5 seconds.

Any alert turns off temporarily.



Control Sounds

Simultaneously press and hold the Lower Temp Set “v” button and Light button for 5 seconds to toggle sounds off and on.



The default setting for sounds is On.

Pressing and holding the mute combination buttons will toggle the Lower Temp display between ‘OF’ and ‘On’. If ‘On’, sounds are enabled. If ‘Of’, sounds are muted. ‘OF’ or ‘On’ will display for 2 seconds then the display switches back to the previous temperature setting.

High/Low Temperature Alert



If the Current temperature is 9 °F above the Set temperature for more than 60 minutes, both temperature displays show “H” and the alert icon blinks red.



If the Current temperature is 4 °C below the Set temperature for more than 60 minutes, both temperature displays show “L” and the alert icon blinks red.

Either temperature sensor can trigger a high or low temperature alert.

The alerts will not sound in the first 90 minutes after power on.

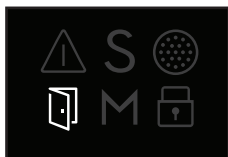

Door Open Alert

When the door stays open for at least 5 minutes, the Door Open icon turns On

and the lights start to dim up and down (from lowest dim level to highest dim level). If the door is kept open an additional 2 minutes or more, an alert sound is played.

Any interaction with the control panel will turn off the blinking lights and audio signal. The Door Open icon stays on as long the door is open and the lights go back to normal.



Change Filter Alert

After 6 months the Change Filter icon turns On.

See “Reset

Filter Alert” section to know how to reset the alert. After resetting the alert, the icon turns Off and the count is reset.

16 Storage Features

Proper Storage

Stocking Recommendations

The wine racks allow for the proper horizontal storage of wine. The bottles are properly positioned so that the wine remains in contact with the cork to assure that the cork does not become dry. White and sparkling wines should be maintained on the bottom to middle racks and red wine on the top racks.

Your Wine Cabinet should be stocked beginning with the bottom display rack at the back and working forward staggering the bottles.

Subsequent racks should be stocked similarly, starting with the back of each rack.



CAUTION

Make sure your cantilever shelf is secure on the shelf supports by pressing down on the shelf before loading the shelf.

Wine Type	Temp in F/C
Vintage Bordeaux	Room Temp not exceeding 68°F/20°C
Cabernet & Merlot: French, Australian, New Zealand, Chilean, Italian, Spanish, Californian, Argentinean, Etc.	68°F/20°C
Red Vintage Pinot Noir	64°F/18°C
Red Grenache, Syrah, Red Pinot Noir	61°F/16°C
White Vintage Chardonnay, Sweet White Vintage: Sauternes...	57°F/14°C
Beaujolais	55°F/13°C
Sweet White Sauternes Barsac, Montbazillac, Ice Wine, Late Harvest, Dry White Gewürztraminer, Riesling, Pinot Grigio, Dry White Chardonnay, Champagne Vintage	50°F/10°C
Dry White Semillon, Sauvignon Blanc	46°F/8°C
Champagne NV, Sparkling, Spumante	43°F/6°C



CAUTION

Never try to move a loaded shelf, remove everything from the shelf before moving. Use both hands when moving the shelf.

Wine bottle storage

- 10 racks for storing
- 149 bottle capacity

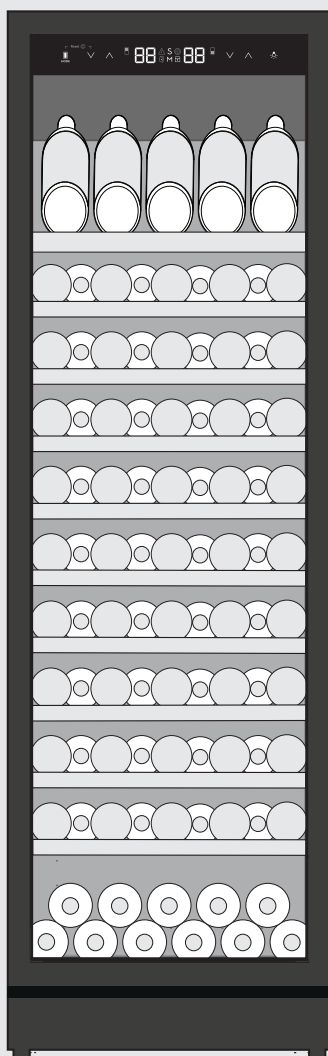

Shelf Types

Display Shelf

- Shipped flat inside cabinet
- Angled on top two liner ribs for bottle display

Fixed Shelf (Two Types)

- Full Width
 - Sits below Display Shelf and below telescopic shelves
 - Fixed to liner rib with screws at the rear
- $\frac{3}{4}$ Width
 - Sits below all other shelves
 - Fixed with rear-mounted shelf restraint

Telescopic Shelves

- Full width
- Fully extend on rails
- Fixed to liner ribs with plastic removable clips

Shelf Removal

The fixed shelves are not intended to be removed from the product.

The telescopic shelves can be removed, but maximum shelf capacity cannot exceed 44 lbs.

To remove the telescoping shelves:

1. Open door to at least 145°.
2. Remove all wine bottles from the shelf.
3. Fully extend shelf.
4. Using a Philips head screwdriver, remove the 4 rail clip screws (2 per rail).
5. Shelf and rails should slide out together.

To reattach shelves, insert rail clip screws into pre-existing holes on the rail supports.

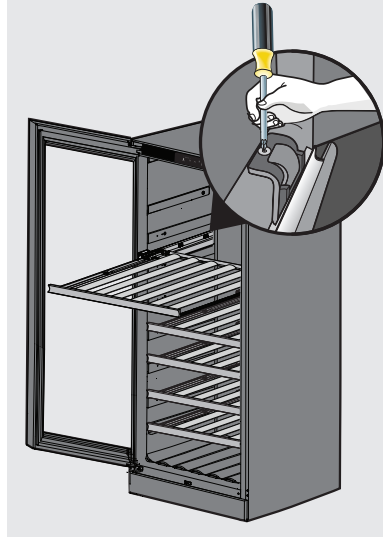

NOTE

It is VERY IMPORTANT to use pre-existing screw holes; attempting to make new ones could jeopardize the strength of the rails and risk failure.

18 Care and Cleaning

Maintaining Your Wine Cabinet

Periodic cleaning and proper maintenance will ensure efficiency, top performance, and long life. The maintenance intervals listed are based on normal conditions. You may want to shorten the intervals if you have pets or other special considerations.

Interior Cleaning - as Required

1. Disconnect power to the Wine Cabinet.
2. Remove racks if desired.
3. Wipe down the interior with a solution of non-abrasive mild detergent and warm water.
4. Rinse with clear water.
5. Reconnect power to the unit.

Should the Wine Cabinet be stored without use for long periods:

- Clean thoroughly.
- Leave the door ajar to allow air to circulate inside the cabinet in order to avoid possible formations of condensation, mold or odors.

Changing your Air Filter

To ensure optimal filtering of wine cabinet odors, change the air filter every six months

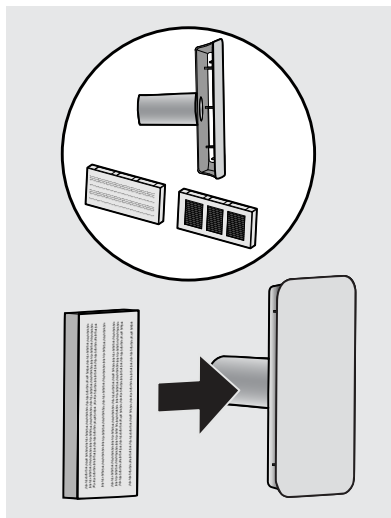

Ordering Replacement Air Filters

Order replacement filters online at www.vintec.com or by calling 1-800-325-1371. Vintec recommends replacing filters at least once every six months.

Before You Call for Service

If the unit appears to be malfunctioning, read through this manual first. If the problem persists, check the Troubleshooting Guide below. Locate the problem in the guide and refer to the cause and its remedy before calling for service. The problem may be something very simple that can be solved without a service call. Consulting or contracting a qualified service technician may be necessary.

If Service is Required

Contact the dealer where you purchased the unit if service is required. State the model and serial number and explain the problem. The model and serial number plate is located on the ceiling of your unit. If you do not know the name of the selling dealer or a local service company, you can check online at www.vintec.com or call 1-800-325-1371.



WARNING

ELECTROCUTION HAZARD

NEVER attempt to repair or perform maintenance on the unit until the main electrical power has been disconnected.

Problem	Possible Cause	Remedy
Unit not cold enough. Adjust temperatures (see "Adjusting the Temperature" in the "Start-Up and Temperature Control" section).	<ul style="list-style-type: none"> Control set too warm. Light staying on. Airflow to front grille blocked. Door gasket not sealing properly. Unit is in DEMO Mode 	<ul style="list-style-type: none"> Adjust temperature colder. Allow 24 hours for temperature to stabilize. Turn off manual light control. See "Controls and Settings" section. Airflow must not be obstructed to front grille. See "Installation" section. Adjust door gasket. See "Controls and Settings" section.
Unit too cold. Contents of unit too cold/frozen. Adjust temperatures (see "Adjusting the Temperature" in the "Start-Up and Temperature Control" section).	<ul style="list-style-type: none"> Control set too cold. 	<ul style="list-style-type: none"> Adjust temperature warmer. Allow 24 hours for temperature to stabilize.
No interior light.	<ul style="list-style-type: none"> Failed LED assembly. Light setting is set to OFF. 	<ul style="list-style-type: none"> Contact a qualified Vintec Service Technician. Check light control. See "Controls and Settings" section.
Light will not go out when door is closed.	<ul style="list-style-type: none"> Manual light control is ON. Door switch not making contact. 	<ul style="list-style-type: none"> Turn off manual light control. See "Operation" section. Check for proper door alignment.

20 Troubleshooting

Problem	Possible Cause	Remedy
Alarm(s) will not shut off.	<ul style="list-style-type: none">• Door is ajar.• Power has failed.• Internal temperature is too high.	<ul style="list-style-type: none">• Press "Alarm" key to acknowledge alarm.• Ensure door is closed firmly.• Allow 24 hours for temperature to stabilize.
Power is not restored after power failure.	<ul style="list-style-type: none">• Circuit breaker has tripped.	<ul style="list-style-type: none">• Verify electrical supply. See "Installation" section.• Recommend unplug and plug the unit back in.
Door does not close properly.	<ul style="list-style-type: none">• Door hinges are misaligned.• Door gasket is not sealing properly.	<ul style="list-style-type: none">• Loosen hinges and re-align door. Retighten hinges.• Turn gasket 180°.

Your appliance is covered by a one year limited warranty. For one year from your original date of purchase, Electrolux will pay all costs for repairing or replacing any parts of this appliance that prove to be defective in materials or workmanship when such appliance is installed, used, and maintained in accordance with the provided instructions. This one year limited warranty may be extended to two years at no cost to you if within 60 days of your purchase you (i) register your appliance with Electrolux and (ii) register as a member of the Vintec Club at [vintecclub.com] or by contacting Electrolux at the addresses or phone numbers below.

Exclusions

This warranty does not cover the following:

1. Products with original serial numbers that have been removed, altered or cannot be readily determined.
2. Product that has been transferred from its original owner to another party or removed outside the USA or Canada.
3. Rust on the interior or exterior of the unit.
4. Products purchased "as-is" are not covered by this warranty.
5. Food or beverage loss due to any refrigerator or freezer failures.
6. Products used in a commercial setting.
7. Service calls which do not involve malfunction or defects in materials or workmanship, or for appliances not in ordinary household use or used other than in accordance with the provided instructions.
8. Service calls to correct the installation of your appliance or to instruct you how to use your appliance.
9. Expenses for making the appliance accessible for servicing, such as removal of trim, cupboards, shelves, etc., which are not a part of the appliance when it is shipped from the factory.
10. Service calls to repair or replace appliance light bulbs, air filters, water filters, other consumables, or knobs, handles, or other cosmetic parts.
11. Pickup and delivery costs; your appliance is designed to be repaired in the home.
12. Surcharges including, but not limited to, any after hour, weekend, or holiday service calls, tolls, ferry trip charges, or mileage expense for service calls to remote areas, including the state of Alaska.
13. Damages to the finish of appliance or home incurred during installation, including but not limited to floors, cabinets, walls, etc.
14. Damages caused by: services performed by unauthorized service companies; use of parts other than genuine Electrolux parts or parts obtained from persons other than authorized service companies; or external causes such as abuse, misuse, inadequate power supply, accidents, fires, or acts of God.

DISCLAIMER OF IMPLIED WARRANTIES; LIMITATION OF REMEDIES

CUSTOMER'S SOLE AND EXCLUSIVE REMEDY UNDER THIS LIMITED WARRANTY SHALL BE PRODUCT REPAIR OR REPLACEMENT AS PROVIDED HEREIN. CLAIMS BASED ON IMPLIED WARRANTIES, INCLUDING WARRANTIES OF MERCHANTABILITY OR FITNESS FOR A PARTICULAR PURPOSE, ARE LIMITED TO ONE YEAR OR THE SHORTEST PERIOD ALLOWED BY LAW, BUT NOT LESS THAN ONE YEAR. ELECTROLUX SHALL NOT BE LIABLE FOR CONSEQUENTIAL OR INCIDENTAL DAMAGES SUCH AS PROPERTY DAMAGE AND INCIDENTAL EXPENSES RESULTING FROM ANY BREACH OF THIS WRITTEN LIMITED WARRANTY OR ANY IMPLIED WARRANTY. SOME STATES AND PROVINCES DO NOT ALLOW THE EXCLUSION OR LIMITATION OF INCIDENTAL OR CONSEQUENTIAL DAMAGES, OR LIMITATIONS ON THE DURATION OF IMPLIED WARRANTIES, SO THESE LIMITATIONS OR EXCLUSIONS MAY NOT APPLY TO YOU. THIS WRITTEN WARRANTY GIVES YOU SPECIFIC LEGAL RIGHTS. YOU MAY ALSO HAVE OTHER RIGHTS THAT VARY FROM STATE TO STATE.

If You Need Service

Keep your receipt, delivery slip, or some other appropriate payment record to establish the warranty period should service be required. If service is performed, it is in your best interest to obtain and keep all receipts. Service under this warranty must be obtained by contacting Electrolux at the addresses or phone numbers below.

This warranty only applies in the USA and Canada. In the USA, your appliance is warranted by Electrolux Major Appliances North America, a division of Electrolux Home Products, Inc. In Canada, your appliance is warranted by Electrolux Canada Corp. Electrolux authorizes no person to change or add to any obligations under this warranty. Obligations for service and parts under this warranty must be performed by Electrolux or an authorized service company. Product features or specifications as described or illustrated are subject to change without notice.

USA
1-877-435-3287
Electrolux Major Appliances North America
10200 David Taylor Drive
Charlotte, NC 28262

Canada
1-800-265-8352
Electrolux Canada Corp.
5855 Terry Fox Way
Mississauga, Ontario,
Canada L5V 3E4