



# COMMERCIAL-STYLE GAS COOKTOP USE AND CARE GUIDE

## TABLE DE CUISSON À GAZ DE STYLE COMMERCIAL

---

Para una versión de estas instrucciones en español, visite [www.jennair.com](http://www.jennair.com)









---

For questions about features, operation/performance, parts, accessories, or service in the U.S.A., call:  
**1-800-JENNAIR (1-800-536-6247)** or visit our website at [www.jennair.com](http://www.jennair.com).









In Canada, call: **1-800-JENNAIR (1-800-536-6247)**, or visit our website at [www.jennair.ca](http://www.jennair.ca).

Au Canada, pour assistance, installation ou service, composez le **1-800-JENNAIR (1-800-536-6247)**  
ou visitez notre site web à [www.jennair.ca](http://www.jennair.ca).

## Table of Contents

<b>SAFETY INFORMATION</b> .....	3
	
<b>PARTS AND FEATURES</b> .....	5
	
<b>COOKTOP FEATURES</b> .....	6
 Burners.....	6
 Chrome Electric Griddle.....	7
Cookware.....	8
Home Canning.....	8
<b>CARE AND CLEANING</b> .....	9
 Cooktop Surface.....	9
 Sealed Surface Burners.....	9
Porcelain-Coated Grates and Caps.....	10
Griddle.....	10
Cooktop Controls.....	11
Stainless Steel.....	11
<b>TROUBLESHOOTING</b> .....	12
	
<b>ASSISTANCE OR SERVICE</b> .....	13
	
<b>ACCESSORIES</b> .....	13
	
<b>WARRANTY</b> .....	14

## Table des matières

<b>INFORMATIONS DE SÉCURITÉ</b> .....	15
	
<b>PIÈCES ET CARACTÉRISTIQUES</b> .....	17
	
<b>CARACTÉRISTIQUES DE LA TABLE DE CUISSON</b> .....	18
 Brûleurs.....	18
 Plaque à frire électrique chromée.....	19
Ustensiles de cuisson.....	21
Préparation de conserves à la maison.....	21
<b>ENTRETIEN ET NETTOYAGE</b> .....	22
 Surface de la table de cuisson.....	22
 Brûleurs de surface scelles.....	22
Grilles et chapeaux emailés.....	23
Plaque à frire.....	23
Commandes de la table de cuisson.....	24
Acier inoxydable.....	24
<b>DÉPANNAGE</b> .....	25
	
<b>ASSISTANCE OU SERVICE</b> .....	26
	
<b>ACCESSOIRES</b> .....	27
	
<b>GARANTIE</b> .....	28



### Your safety and the safety of others are very important.

We have provided many important safety messages in this manual and on your appliance. Always read and obey all safety messages.



This is the safety alert symbol.

This symbol alerts you to potential hazards that can kill or hurt you and others.

All safety messages will follow the safety alert symbol and either the word "DANGER" or "WARNING."

These words mean:

**⚠ DANGER**

You can be killed or seriously injured if you don't immediately follow instructions.

**⚠ WARNING**

You can be killed or seriously injured if you don't follow instructions.

All safety messages will tell you what the potential hazard is, tell you how to reduce the chance of injury, and tell you what can happen if the instructions are not followed.

**WARNING: If the information in these instructions is not followed exactly, a fire or explosion may result causing property damage, personal injury or death.**

- Do not store or use gasoline or other flammable vapors and liquids in the vicinity of this or any other appliance.
- **WHAT TO DO IF YOU SMELL GAS:**
  - Do not try to light any appliance.
  - Do not touch any electrical switch.
  - Do not use any phone in your building.
  - Immediately call your gas supplier from a neighbor's phone. Follow the gas supplier's instructions.
  - If you cannot reach your gas supplier, call the fire department.
- Installation and service must be performed by a qualified installer, service agency or the gas supplier.

**WARNING:** Gas leaks cannot always be detected by smell.

Gas suppliers recommend that you use a gas detector approved by UL or CSA.

For more information, contact your gas supplier.

If a gas leak is detected, follow the "What to do if you smell gas" instructions.

State of California Proposition 65 Warnings:

**WARNING:** This product contains one or more chemicals known to the State of California to cause cancer.

**WARNING:** This product contains one or more chemicals known to the State of California to cause birth defects or other reproductive harm.



## SAFETY INFORMATION

### IMPORTANT SAFETY INSTRUCTIONS

**WARNING:** To reduce the risk of fire, electrical shock, injury to persons, or damage when using the cooktop, follow basic precautions, including the following:

- **WARNING:** NEVER use this appliance as a space heater to heat or warm the room. Doing so may result in carbon monoxide poisoning and overheating of the cooktop.
- **CAUTION:** Do not store items of interest to children in cabinets above the cooktop – children climbing on the cooktop to reach items could be seriously injured.
- Proper Installation – The cooktop, when installed, must be electrically grounded in accordance with local codes or, in the absence of local codes, with the *National Electrical Code, ANSI/NFPA70 or the Canadian Electrical Code, Part 1*. Be sure the cooktop is properly installed and grounded by a qualified technician.
- This cooktop is equipped with a three-prong grounding plug for your protection against shock hazard and should be plugged directly into a properly grounded receptacle. Do not cut or remove the grounding prong from this plug.
- Disconnect the electrical supply before servicing the cooktop.
- Injuries may result from the misuse of the cooktop such as stepping, leaning, or sitting on the top surface.
- Maintenance – Keep cooktop area clear and free from combustible materials, gasoline, and other flammable vapors and liquids.
- Storage on the cooktop – Flammable materials should not be stored on or near surface units.
- Top burner flame size should be adjusted so it does not extend beyond the edge of the cooking utensil.

**SAVE THESE INSTRUCTIONS**

# PARTS AND FEATURES



These instructions cover several different models. The cooktop you have purchased may have some or all of the items listed. The locations and appearances of the features shown here may not match those of your model. Refer to these instructions or the "Frequently Asked Questions (FAQs)" section of our website at [producthelp.jennair.com](http://producthelp.jennair.com) for more detailed instructions. In Canada, refer to the Customer Service Section at [www.jennair.ca](http://www.jennair.ca).

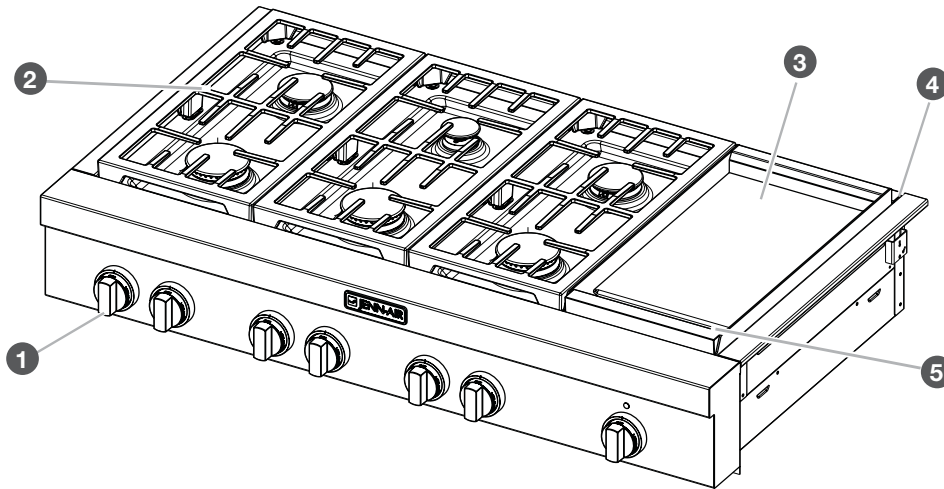

- 1 Commercial-style die cast metal control knobs
- 2 Heavy duty double grate design
- 3 Electric chrome griddle (on some models)
- 4 Island trim
- 5 Drip tray (on griddle models)

#### Not shown:

- Optional backguards
- Optional griddle cover
- Optional wok ring



# COOKTOP FEATURES

## BURNERS

### **WARNING**



#### Fire Hazard

Do not let the burner flame extend beyond the edge of the pan.

Turn off all controls when not cooking.

Failure to follow these instructions can result in death or fire.

- Check that the control knob is pressed completely down on the valve shaft. If the spark igniter still does not operate, call a trained repair specialist.
- When the control knobs for any small or medium burner are turned to Lite, all small and medium burners will click. When the control knob for the large burner is turned to Lite, these burners will click independently of the other burners. In both cases, only the burner with the control knob turned to Lite will produce a flame.

**REMEMBER:** When cooktop is in use or during the Self-Cleaning cycle, the entire cooktop area may become hot.

### Reignition Feature

During cooktop use, if one or more burners are extinguished due to external causes (such as a water spill, wind, or ventilation draft), the ignition system will turn on to reignite the flame. When the flame comes back on, the system will stop sparking. If the draft in the room is not removed, occasional sparking may continue. Sparking may also occasionally occur when using the low setting on a burner.

### To Set a Burner:

<b>1.</b>	<b>2.</b>
Push in and turn counterclockwise to LITE.	Turn knob counterclockwise between HI and LO.

Push in one more time to get from Lo to Hi.

### In Case of Power Failure

Hold a lit match near a burner and turn knob counterclockwise to HI. After burner lights, turn knob to the desired setting.

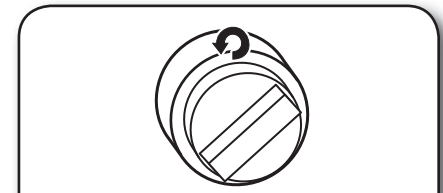
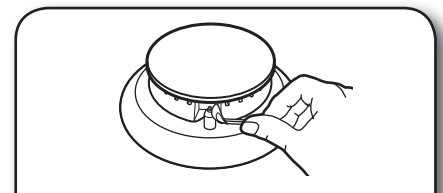

BTU/Hr	BURNER APPEARANCE	FEATURES
Ultra-Power™ dual-flame burner		This burner has an upper and lower level of flame. The Power Hi setting uses both flame levels at full power to provide the highest heat. It is ideal for cooking large quantities of food or liquid and using large pots and pans. The Simmer Hi and Lo settings use the upper flame only.
Medium burner		This burner is ideal for cooking smaller quantities of food and melting chocolate or butter.
Simmer burner		This burner reaches a low of 500 BTU/Hr. It provides the gentle, low temperatures required for simmering soups, stewing, and melting delicate ingredients like butter, cheese, and chocolate.

### Igniting Burners:

- Electric igniters automatically light the surface burners when control knobs are turned to Lite.
- Before setting a control knob, place filled cookware on the grate. Do not operate a burner using empty cookware or without any cookware on the grate.
- Visually check that the burner has lit. If the burner does not ignite, listen for the clicking sound. If you do not hear the igniter click, turn off the burner. Check for a tripped circuit breaker or blown fuse.



## Sealed Surface Burners

Sealed surface burners are designed to minimize gaps and seams that can allow liquids and spills to get under the cooktop. This design makes cleanup quick and easy.

### Stacked Power Burner

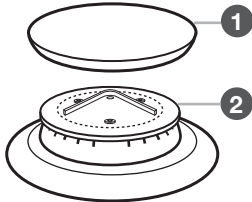

- 1 Burner cap
- 2 Burner base
- 3 Choke (for use with medium burner, Propane gas only)

### Medium Burner

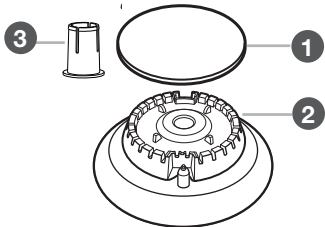

### Simmer/Melt Burner

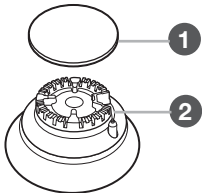

**IMPORTANT:** Do not obstruct the flow of combustion and ventilation air around the burner grate edges.

**Burner cap:** Always keep the burner cap in place when using a surface burner. A clean burner cap will help avoid poor ignition and uneven flames. Always clean the burner cap after a spillover and routinely remove and clean the caps according to the "Care and Cleaning" section.

**Gas opening:** Gas must flow freely throughout the gas opening for the burner to light properly. Keep this area free of soil and do not allow spills, food, cleaning agents, or any other material to enter the gas opening. Keep spillovers out of the gas opening by always using a burner cap.

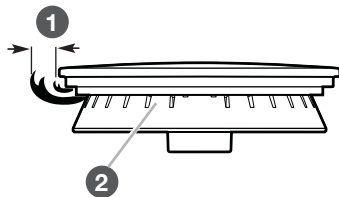

- 1 1-1/2" (2.5-3.8 cm)
- 2 Burner ports

**Burner ports:** Check burner flames occasionally for proper size and shape as shown above. A good flame is blue in color, not yellow. Keep this area free of soil and do not allow spills, food, cleaning agents, or any other material to enter the burner ports.

## CHROME ELECTRIC GRIDDLE (ON SOME MODELS)

The chrome electric griddle provides the perfect cooking surface for grilled sandwiches, pancakes, eggs, burgers, sautéed vegetables, and many more family favorites. The attractive low-stick surface is designed to make cleanup easy.

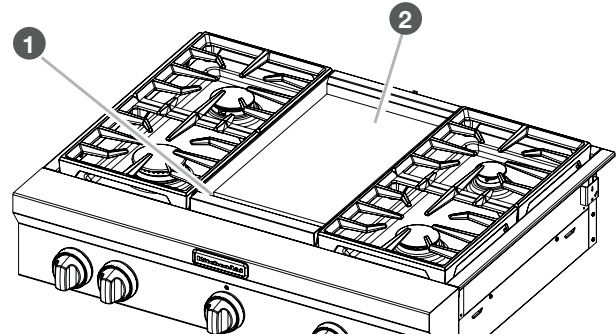

- 1 Drip tray
- 2 Griddle

The chrome electric griddle system provides an evenly heated cooking surface.

- Be sure plastic film has been removed and wash with hot water before first use.
- To avoid scratching the griddle, do not place any pots or pans on the griddle. Use only heat-resistant plastic or wooden utensils.
- The griddle surface is ready to use and does not need to be seasoned.
- Pouring cold water on a hot griddle may warp the griddle, resulting in an uneven cooking surface.

### To Use:

**1.**

Position drip tray.

**2.**

Push in and turn knob.

**3.**

Place food on griddle and cook to desired doneness.

The griddle light will turn off when the griddle has finished preheating. The griddle light will turn on and off during use to indicate that the griddle element is maintaining the selected surface temperature.



# COOKTOP FEATURES

## Griddle Charts

The settings and times are guidelines only and may need to be adjusted for individual tastes.

### Preheat Chart

TEMPERATURE	TIME TO PREHEAT (in minutes)
250°F (121°C)	10
300°F (149°C)	14
350°F (177°C)	15
400°F (204°C)	20
450°F (232°C)	25
500°F (260°C)	27

### Cooking Chart

FOOD	SETTING	COOK TIME TOTAL MINUTES
Sausage patties and links	325°F (163°C)	12-18
Bacon slices	350°F (177°C)	7-11
Ham steak (fully cooked)	325°F (163°C)	5-7
Frankfurters and precooked sausages	325°F (163°C)	8-15
Ground meat patties	350°F (177°C)	10-15
Grilled sandwiches	325°F (163°C)	3-5
Fish steaks, fillets	325°F (163°C)	8-15
Eggs	300°F (149°C)	3-5
Hash brown potatoes	400°F to 425°F (204°C to 218°C)	8-12
French toast	350°F (177°C)	5-7
Pancakes	350°F (177°C)	2-4

## COOKWARE

**IMPORTANT:** Do not leave empty cookware on a hot surface cooking area, element, or surface burner.

Ideal cookware should have a flat bottom, straight sides, and a well-fitting lid and the material should be of medium-to-heavy thickness.

Rough finishes may scratch the cooktop or grates. Aluminum and copper may be used as a core or base in cookware.

However, when used as a base, they can leave permanent marks on the cooktop or grates.

Cookware material is a factor in how quickly and evenly heat is transferred which affects cooking results. A nonstick finish has the same characteristics as its base material. For example, aluminum cookware with a nonstick finish will take on the properties of aluminum.

Cookware with nonstick surfaces should not be used under the broiler.

Use the following chart as a guide for cookware material characteristics.

COOKWARE	CHARACTERISTICS
<b>Aluminum</b>	<ul style="list-style-type: none"> <li>■ Heats quickly and evenly.</li> <li>■ Suitable for all types of cooking</li> <li>■ Medium or heavy thickness is best for most cooking tasks.</li> </ul>
<b>Cast iron</b>	<ul style="list-style-type: none"> <li>■ Heats slowly and evenly.</li> <li>■ Good for browning and frying</li> <li>■ Maintains heat for slow cooking.</li> </ul>
<b>Ceramic or ceramic glass</b>	<ul style="list-style-type: none"> <li>■ Follow manufacturer's instructions.</li> <li>■ Heats slowly, but unevenly.</li> <li>■ Ideal results on low-to-medium heat settings</li> </ul>
<b>Copper</b>	<ul style="list-style-type: none"> <li>■ Heats very quickly and evenly.</li> </ul>
<b>Earthenware</b>	<ul style="list-style-type: none"> <li>■ Follow manufacturer's instructions.</li> <li>■ Use on low heat settings.</li> </ul>
<b>Porcelain enamel on steel or cast iron</b>	<ul style="list-style-type: none"> <li>■ See stainless steel or cast iron.</li> </ul>
<b>Stainless steel</b>	<ul style="list-style-type: none"> <li>■ Heats quickly, but unevenly.</li> <li>■ A core or base of aluminum or copper on stainless steel provides even heating.</li> </ul>

## HOME CANNING

When canning for long periods, alternate the use of surface burners between batches. This allows time for the most recently used areas to cool.

- Center the canner on the grate.
- Do not place canner on two surface burners at the same time.
- For more information, contact your local agricultural department. Companies that manufacture home canning products can also offer assistance.





## COOKTOP SURFACE

**IMPORTANT:** Before cleaning, make sure all controls are off and the cooktop is cool. Always follow label instructions on cleaning products.

After Each Use:

1.

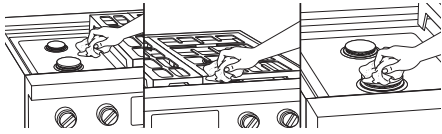

Wipe off cooktop, grates, and caps.

2.

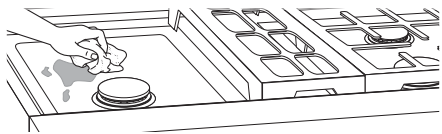

Clean food spills.

To preserve the finish, clean food spills containing acids, such as vinegar and tomato, as soon as the entire appliance is cool.

## SEALED SURFACE BURNERS

1.

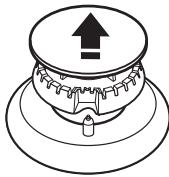

Remove burner cap and base.

2.

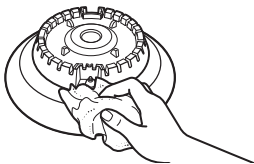

Wipe off cooktop, grates, and caps.

3.

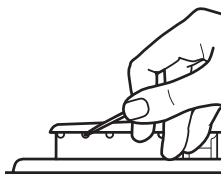

Clean clogged burner ports.

Use a straight pin. Do not enlarge or distort the port. Do not use a wooden toothpick. If the burner needs to be adjusted, contact a trained repair specialist.

4. Replace burner cap.

### Dual-Flame Burner

1

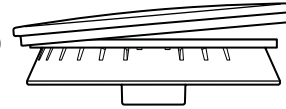

1 Incorrect

2 Correct

2

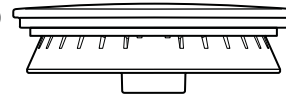

### Medium Burner

1

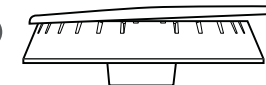

1 Incorrect

2 Correct

2

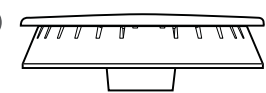

### Simmer/Melt Burner

1

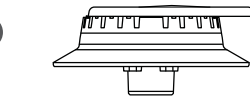

1 Incorrect

2 Correct

2

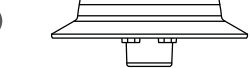

Make sure alignment pins are properly aligned with burner cap.

5.

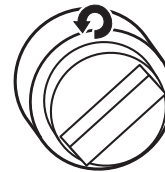

Turn on burner.

If the burner does not light, check cap alignment. If the burner still does not light, do not service the sealed burner yourself. Contact a trained repair specialist.



## CARE AND CLEANING

### PORCELAIN-COATED GRATES AND CAPS

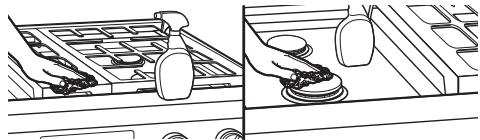

Use scrub pad and cleanser.

Clean with a nonabrasive nylon scrub pad and mildly abrasive cleanser.

#### Know Your Grates and Caps

- Food spills containing acids, such as vinegar and tomato, should be cleaned as soon as the cooktop, grates, and caps are cool. These spills may affect the finish.
- To avoid chipping, do not bang grates and caps against each other or hard surfaces such as cast iron cookware.
- Do not reassemble caps on burners while wet.
- Do not clean in the Self-Cleaning cycle.
- Do not clean in dishwasher.

### GRIDDLE

#### Tips:

- Prior to cleaning the griddle, make sure that all cooktop burners have been turned off and the oven controls have been locked.
- For best results, clean the griddle shortly after removing the food.

#### Do Not Use:

- Soap
- Abrasive materials
- Cleaning materials, including stainless steel cleaner

#### After Each Use:

**1.** Heat for 10 to 15 minutes at 300°F (149°C).

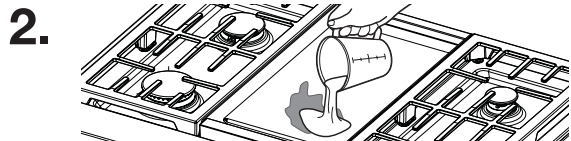

Pour water on soiled area.

Using a measuring cup, pour up to 1 cup (236.6 mL) tap water over the soiled area, starting at the back, allowing the water to run toward the drip tray in the front. Allow the water to bubble on the griddle for 3 to 4 seconds.

**3.**

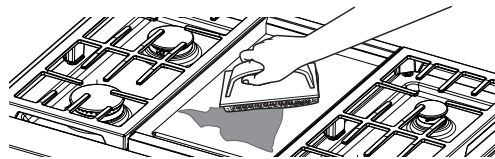

Scrape residue into drip tray.

Use a pad holder or wooden spoon with non-scratch pad. Use pressure on soiled areas. Repeat if needed for heavy soils.

**4.**

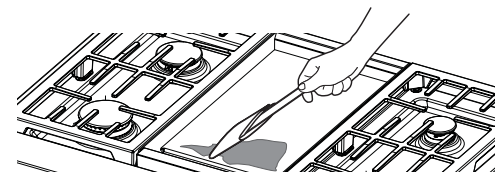

Remove remaining residue.

Fold a damp towel and, with the pad holder or wooden spoon, go over the griddle to remove remaining residue.

**5.**

Turn off griddle and let cool.

**6.**

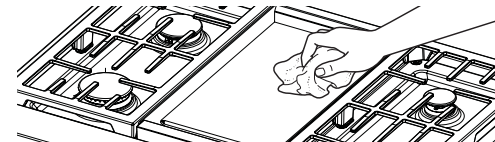

Wipe off griddle.

Once cool, wipe the griddle with a clean, damp terry cloth towel. Then buff with a microfiber cloth. If streaking, rainbowing, or ghosting occurs, use a mixture of 1 part white vinegar to 2 parts water on a towel to wipe the griddle.

**7.**

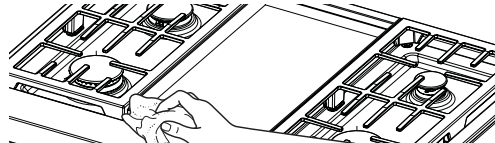

Remove, empty, and clean drip tray.

Clean the drip tray with warm soapy water. Wipe the area under the drip tray clean. Once dry, put the drip tray back in position.



## COOKTOP CONTROLS

1.

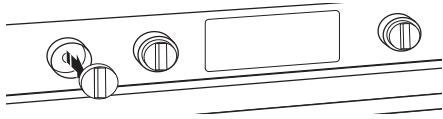

Remove knobs.

Pull the knobs straight away from the control panel to remove.

2.

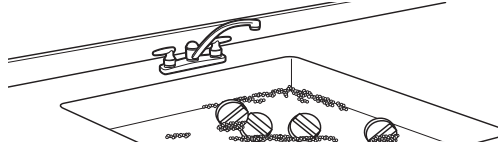

Clean with warm, soapy water.

### Know Your Cooktop Controls

- To avoid damage to the cooktop controls, do not use steel wool, abrasive cleansers, or oven cleaner.
- To avoid damage, do not soak knobs.
- When replacing knobs, make sure knobs are in the Off position.
- Do not remove seals under knobs.
- When replacing knobs after cleaning either the surface burner controls or the griddle module control, make sure the knobs are replaced to the correct location. The power burner knobs have power settings and the griddle knob has temperature settings. All other knobs have Hi, Med, Lo settings only.

## STAINLESS STEEL (ON SOME MODELS)

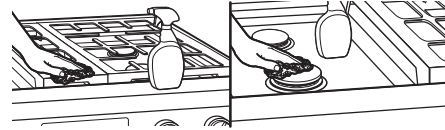

Use cleaner or wipes.

Use affresh® Stainless Steel Cleaner or affresh® Stainless Steel Cleaning Wipes (not included). Rub in direction of grain to avoid possible damage to the steel surface.

### Do Not Use:

- Soap-filled scouring pads
- Abrasive cleaners
- Cooktop polishing creme
- Steel-wool pads
- Gritty washcloths
- Abrasive paper towels



# TROUBLESHOOTING

First try the solutions suggested here. If you need further assistance or more recommendations that may help you avoid a service call, refer to the warranty page in these instructions and scan the code there with your mobile device, or visit [producthelp.jennair.com](http://producthelp.jennair.com). In Canada, visit [www.jennair.ca](http://www.jennair.ca).

If you experience	Possible causes	Solution
Nothing will operate	A household fuse has blown or a circuit breaker has tripped.	Replace the fuse or reset the circuit breaker. If the problem continues, call an electrician.
Surface burners will not operate	This is the first time the surface burners have been used.	Turn on any one of the surface burner knobs to release air from the gas lines.
	The control knob is not set correctly.	Push in knob before turning to a setting.
	The burner ports are clogged.	Clean clogged burner ports with a straight pin.
Surface burner flames are uneven, yellow, and/or noisy	The burner ports are clogged.	Clean clogged burner ports with a straight pin.
	On models with caps, the burner caps are not positioned properly.	Make sure alignment pins are properly aligned with the burner cap.
	Propane gas is being used.	The cooktop may have been converted improperly. Contact a trained repair specialist.
Surface burner makes popping noises	The burner is wet.	Let it dry.
Burner sparks but does not light	There is continuous sparking, but the burner does not light.	Discontinue use of the surface burner and contact a service technician.
Excessive heat around cookware on cooktop	The cookware is not the proper size.	Use cookware about the same size as the surface cooking area, element, or surface burner. Cookware should not extend more than 1/2" (1.3 cm) outside the cooking area.
Cooktop cooking results not what expected	The proper cookware is not being used.	Use medium-to-heavy cookware made of the material that cooks food the way you want. The best cookware should have a flat bottom, straight sides, and a well-fitting lid.
	The control knob is not set to the proper heat level.	Set the Cooktop Control to HI, MED, or LO, depending upon the type of cooking you want to do.
	The cooktop is not level.	The cooktop must be level for the griddle to operate properly. See the Installation Instructions for leveling instructions.

## ASSISTANCE OR SERVICE



Before calling for assistance or service, please check the “Troubleshooting” section. It may save you the cost of a service call. If you still need help, follow the instructions below. When calling, please know the purchase date and the complete model and serial number of your appliance. This information will help us to better respond to your request.

### If you need replacement parts

If you need to order replacement parts, we recommend that you use only factory specified parts. These factory specified parts will fit right and work right because they are made with the same precision used to build every new Jenn-Air® appliance.

To locate factory specified parts in your area, call us or your nearest Jenn-Air designated service center.

### IN THE U.S.A.

Call the Jenn-Air Customer eXperience Center toll free: **1-800-JENNAIR (1-800-536-6247)** or visit our website at **www.jennair.com**.

#### Our consultants provide assistance with:

- Scheduling of service. Jenn-Air® appliances designated service technicians are trained to fulfill the product warranty and provide after-warranty service anywhere in the United States.
- Features and specifications on our full line of appliances.
- Referrals to local Jenn-Air® appliance dealers.
- Installation information.
- Use and maintenance procedures.
- Accessory and repair parts sales.
- Specialized customer assistance (Spanish speaking, hearing impaired, limited vision, etc.).

#### For further assistance

If you need further assistance, you can write to Jenn-Air with any questions or concerns at:

Jenn-Air Brand Home Appliances  
Customer eXperience Center  
553 Benson Road  
Benton Harbor, MI 49022-2692

Please include a daytime phone number in your correspondence.

### IN CANADA

Call the Jenn-Air Canada Customer eXperience Centre toll free: **1-800-JENNAIR (1-800-536-6247)** or visit our website at **www.jennair.ca**.

#### Our consultants provide assistance with:

- Scheduling of service. Jenn-Air® appliances designated service technicians are trained to fulfill the product warranty and provide after-warranty service anywhere in Canada.
- Features and specifications on our full line of appliances.
- Referrals to local Jenn-Air® appliance dealers.
- Installation information.
- Use and maintenance procedures.
- Accessory and repair parts sales.

#### For further assistance

If you need further assistance, you can write to Jenn-Air Canada with any questions or concerns at:

Customer eXperience Centre  
Jenn-Air Canada  
200 - 6750 Century Ave.  
Mississauga, Ontario L5N 0B7

Please include a daytime phone number in your correspondence.

## ACCESSORIES



For accessories in the U.S.A., you can visit our website at **www.jennair.com** or call us at **1-800-JENNAIR (1-800-536-6247)**. In Canada, visit our website at **www.jennair.ca** or call us at **1-800-JENNAIR (1-800-536-6247)**. Or see the “Accessories” brochure to order.

**affresh® Stainless Steel Cleaner and Polish**  
(stainless steel models)

**affresh® Stainless Steel Wipes**  
(stainless steel models)

**affresh® Cooktop Cleaner**

**Cooktop Protectant**

**Gas Grate/Drip Pan Cleaner**

**affresh® Kitchen and Appliance Cleaner**

**Griddle**

**Wok Ring**

**19<sup>11/16</sup>" (50.0 cm) to 39" (99.0 cm) Adjustable Backguard for 30" (76.2 cm) Ranges and Cooktops**  
**19<sup>11/16</sup>" (50.0 cm) to 39" (99.0 cm) Adjustable Backguard for 36" (91.4 cm) Ranges and Cooktops**  
**19<sup>11/16</sup>" (50.0 cm) to 39" (99.0 cm) Adjustable Backguard for 48" (121.9 cm) Ranges and Cooktops**

**9" (22.9 cm) Backguard for 30" (76.2 cm) Ranges and Cooktops**  
**9" (22.9 cm) Backguard for 36" (91.4 cm) Ranges and Cooktops**  
**9" (22.9 cm) Backguard for 48" (121.9 cm) Ranges and Cooktops**

**33<sup>1/2</sup>" (85.0 cm) Retractable Backguard with Dual-Position Shelf for 30" (76.2 cm) Ranges and Cooktops**  
**33<sup>1/2</sup>" (85.0 cm) Retractable Backguard with Dual-Position Shelf for 36" (91.4 cm) Ranges and Cooktops**  
**33<sup>1/2</sup>" (85.0 cm) Retractable Backguard with Dual-Position Shelf for 48" (121.9 cm) Ranges and Cooktops**

# JENN-AIR® COOKING LIMITED WARRANTY

ATTACH YOUR RECEIPT HERE. PROOF OF PURCHASE IS REQUIRED TO OBTAIN WARRANTY SERVICE.

Please have the following information available when you call the Customer eXperience Center:

- Name, address and telephone number
- Model number and serial number
- A clear, detailed description of the problem
- Proof of purchase including dealer or retailer name and address



<https://jennair.custhelp.com>

## IF YOU NEED SERVICE:

1. Before contacting us to arrange service, please determine whether your product requires repair. Some questions can be addressed without service. Please take a few minutes to review the Troubleshooting or Problem Solver section of the Use and Care Guide, scan the QR code on the right to access additional resources, or visit <https://jennair.custhelp.com>.
2. All warranty service is provided exclusively by our authorized Jenn-Air Service Providers. In the U.S. and Canada, direct all requests for warranty service to:

**Jenn-Air Customer eXperience Center**  
**1-800-JENNAIR (1-800-536-6247).**

## FIVE YEAR LIMITED WARRANTY

### WHAT IS COVERED

#### TWO YEAR LIMITED WARRANTY (PARTS & LABOR)

For two years from the date of purchase, when this major appliance is installed, operated and maintained according to instructions attached to or furnished with the product, Jenn-Air brand of Whirlpool Corporation or Whirlpool Canada, LP (hereafter "Jenn-Air") will pay for factory specified replacement parts and repair labor to correct defects in materials or workmanship that existed when this major appliance was purchased or, at its sole discretion replace the product. In the event of product replacement, your appliance will be warranted for the remaining term of the original unit's warranty period.

#### THIRD THROUGH FIFTH YEAR LIMITED WARRANTY (CERTAIN COMPONENT PARTS ONLY - LABOR NOT INCLUDED)

In the third through fifth years from the date of original purchase, when this major appliance is installed, operated and maintained according to instructions attached to or furnished with the product, Jenn-Air will pay for factory specified parts for the following components to correct non-cosmetic defects in materials or workmanship in these parts that prevent function of this major appliance and that existed when this major appliance was purchased. This is a limited 5-year warranty on the below named parts only and does not include repair labor.

- Electric element
- Touch Pad and microprocessor
- Glass ceramic cooktop: if due to thermal breakage
- Electronic controls
- Magnetron tube
- Sealed gas burners

YOUR SOLE AND EXCLUSIVE REMEDY UNDER THIS LIMITED WARRANTY SHALL BE PRODUCT REPAIR AS PROVIDED HEREIN. Service must be provided by a Jenn-Air designated service company. This limited warranty is valid only in the United States or Canada and applies only when the major appliance is used in the country in which it was purchased. This limited warranty is effective from the date of original consumer purchase. Proof of original purchase date is required to obtain service under this limited warranty.

### WHAT IS NOT COVERED

1. Commercial, non-residential, multiple-family use, or use inconsistent with published user, operator or installation instructions.
2. In-home instruction on how to use your product.
3. Service to correct improper product maintenance or installation, installation not in accordance with electrical or plumbing codes or correction of household electrical or plumbing (i.e. house wiring, fuses or water inlet hoses).
4. Consumable parts (i.e. light bulbs, batteries, air or water filters, preservation solutions, etc.).
5. Defects or damage caused by the use of non-genuine Jenn-Air parts or accessories.
6. Conversion of products from natural gas or L.P. gas.
7. Damage from accident, misuse, abuse, fire, floods, acts of God or use with products not approved by Jenn-Air.
8. Repairs to parts or systems to correct product damage or defects caused by unauthorized service, alteration or modification of the appliance.
9. Cosmetic damage including scratches, dents, chips, and other damage to the appliance finishes unless such damage results from defects in materials and workmanship and is reported to Jenn-Air within 30 days.
10. Discoloration, rust or oxidation of surfaces resulting from caustic or corrosive environments including but not limited to high salt concentrations, high moisture or humidity or exposure to chemicals.
11. Food or medicine loss due to product failure.
12. Pick-up or delivery. This product is intended for in-home repair.
13. Travel or transportation expenses for service in remote locations where an authorized Jenn-Air servicer is not available.
14. Removal or reinstallation of inaccessible appliances or built-in fixtures (i.e. trim, decorative panels, flooring, cabinetry, islands, countertops, drywall, etc.) that interfere with servicing, removal or replacement of the product.
15. Service or parts for appliances with original model/serial numbers removed, altered or not easily determined.

**The cost of repair or replacement under these excluded circumstances shall be borne by the customer.**

### DISCLAIMER OF IMPLIED WARRANTIES

IMPLIED WARRANTIES, INCLUDING ANY IMPLIED WARRANTY OF MERCHANTABILITY OR IMPLIED WARRANTY OF FITNESS FOR A PARTICULAR PURPOSE, ARE LIMITED TO ONE YEAR OR THE SHORTEST PERIOD ALLOWED BY LAW. Some states and provinces do not allow limitations on the duration of implied warranties of merchantability or fitness, so this limitation may not apply to you. This warranty gives you specific legal rights, and you also may have other rights that vary from state to state or province to province.

### DISCLAIMER OF REPRESENTATIONS OUTSIDE OF WARRANTY

Jenn-Air makes no representations about the quality, durability, or need for service or repair of this major appliance other than the representations contained in this warranty. If you want a longer or more comprehensive warranty than the limited warranty that comes with this major appliance, you should ask Jenn-Air or your retailer about buying an extended warranty.

### LIMITATION OF REMEDIES; EXCLUSION OF INCIDENTAL AND CONSEQUENTIAL DAMAGES

YOUR SOLE AND EXCLUSIVE REMEDY UNDER THIS LIMITED WARRANTY SHALL BE PRODUCT REPAIR AS PROVIDED HEREIN. JENN-AIR SHALL NOT BE LIABLE FOR INCIDENTAL OR CONSEQUENTIAL DAMAGES. Some states and provinces do not allow the exclusion or limitation of incidental or consequential damages, so these limitations and exclusions may not apply to you. This warranty gives you specific legal rights, and you also may have other rights that vary from state to state or province to province.

