

**Use & Care Guide**  
**Manual de Uso y Cuidado**



# Kenmore®

## Bottom Freezer Refrigerator Congelador Inferior Refrigerador

**Model/Modelo: 7135# - PreView Grab-N-Go™**

**Model/Modelo: 7035# - Standard**

# = color number, número de color



MFL70761722  
Rev.01\_110119

Transform SR Brands Management LLC  
Hoffman Estates, IL 60179 U.S.A.  
[www.kenmore.com](http://www.kenmore.com)



## TABLE OF CONTENTS

<p><b>Warranty</b>..... 3</p> <p><b>Product Record</b> ..... 4</p> <p><b>Important Safety Instructions</b> ..... 5-7</p> <p><b>Electrical &amp; Grounding Requirements</b> ..... 7</p> <p><b>Parts and Features</b> ..... 8</p> <p><b>Refrigerator Installation</b> ..... 9-18</p> <p style="padding-left: 20px;">Unpacking Your Refrigerator ..... 9</p> <p style="padding-left: 20px;">Dimensions and Clearances ..... 9</p> <p style="padding-left: 20px;">Installation .....10</p> <p style="padding-left: 20px;">Removing/Replacing Handles, Doors, and Drawers..... 11-17</p> <p style="padding-left: 20px;">Leveling and Door Alignment .....18</p> <p><b>Using Your Refrigerator</b> .....19-32</p> <p style="padding-left: 20px;">Setting the Controls ..... 19-20</p> <p style="padding-left: 20px;">Smart Features .....21</p> <p style="padding-left: 20px;">Instructions for Smart Grid ..... 22-23</p> <p style="padding-left: 20px;">In-Door Ice Bin .....24</p> <p style="padding-left: 20px;">Automatic Icemaker ..... 25-26</p> <p style="padding-left: 20px;">Food Storage Guide ..... 26</p> <p style="padding-left: 20px;"><b>► Refrigerator Section</b></p> <p style="padding-left: 20px;">Water Dispenser .....27</p> <p style="padding-left: 20px;">Refrigerator Shelves ..... 28</p> <p style="padding-left: 20px;">Humidity Controlled Crisper ..... 29</p> <p style="padding-left: 20px;">Pantry Drawer ..... 29</p> <p style="padding-left: 20px;">Door Bin ..... 29</p> <p style="padding-left: 20px;">PreView Grab-N-Go .....30</p> <p style="padding-left: 20px;">Grab-N-Go Case.....30</p> <p style="padding-left: 20px;">Replacing the Air Filter ..... 31</p>	<p style="padding-left: 20px;"><b>► Freezer Section</b></p> <p style="padding-left: 20px;">Extra Ice Bin .....31</p> <p style="padding-left: 20px;">Durabase ..... 32</p> <p style="padding-left: 20px;">Durabase Divider ..... 32</p> <p style="padding-left: 20px;">Pullout Drawers ..... 32</p> <p><b>Water Filter</b> ..... 33-35</p> <p><b>Care and Cleaning</b> .....36-37</p> <p style="padding-left: 20px;">General Cleaning Tips .....36</p> <p style="padding-left: 20px;">Exterior ..... 36</p> <p style="padding-left: 20px;">Inside Walls ..... 36</p> <p style="padding-left: 20px;">Door Liner and Gaskets ..... 36</p> <p style="padding-left: 20px;">Plastic Parts ..... 36</p> <p style="padding-left: 20px;">Condenser Coils ..... 36</p> <p style="padding-left: 20px;">Light Bulb Replacement .....37</p> <p style="padding-left: 20px;">Power Interruptions .....37</p> <p style="padding-left: 20px;">When You Go On Vacation .....37</p> <p style="padding-left: 20px;">When You Move .....37</p> <p><b>Connecting the Water Line</b> .....38-40</p> <p><b>Troubleshooting Guide</b> ..... 41-48</p> <p><b>Service</b> .....Back Cover</p>
---	--

# WARRANTY



## REFRIGERATOR WARRANTY

### **KENMORE LIMITED WARRANTY**

WITH PROOF OF SALE, the following warranty coverage applies when this appliance is correctly installed, operated and maintained according to all supplied instructions.

#### **One Year on Appliance**

FOR ONE YEAR from the date of sale this appliance is warranted against defects in material or workmanship. A defective appliance will receive free repair. If the appliance cannot be repaired it will be replaced free of charge.

#### **Lifetime on Storage Bins**

FOR AS LONG AS IT IS USED from the date of sale, a free replacement will be supplied for a defective refrigerator or freezer compartment storage bin.\* If the defect appears within the first year, a new bin will be installed at no charge. If the defect appears after the first year, a new bin will be supplied but not installed at no charge. This Lifetime warranty covers only storage bins, and does not apply to any other related component or mechanism. You are responsible for the labor cost of bin installation after the first year from the date of sale. This warranty coverage applies for only 90 days from the date of sale if the appliance is ever used for other than private household purposes. \*Warranty coverage applies to door bins, drawer bins and basket bins. Defects must be verified by a Sears authorized service representative.

For warranty coverage details to obtain free repair or replacement, visit the web page: [www.kenmore.com/warranty](http://www.kenmore.com/warranty)

All warranty coverage applies for only 90 days from the sale date if the appliance is ever used for other than private household purposes.

#### **This warranty covers ONLY defects in material and workmanship, and will NOT pay for:**

1. Expendable items that can wear out from normal use, including but not limited to filters, belts, bags or screw-in base light bulbs.
2. A service technician to clean or maintain this appliance, or to instruct the user in correct appliance installation, operation and maintenance.
3. Service calls to correct appliance installation not performed by Sears authorized service agents, or to repair problems with house fuses, circuit breakers, house wiring, and plumbing or gas supply systems resulting from such installation.
4. Damage to or failure of this appliance resulting from installation not performed by Sears authorized service agents, including installation that was not in accord with electrical, gas or plumbing codes.
5. Damage to or failure of this appliance, including discoloration or surface rust, if it is not correctly operated and maintained according to all supplied instructions.
6. Damage to or failure of this appliance, including discoloration or surface rust, resulting from accident, alteration, abuse, misuse or use for other than its intended purpose.
7. Damage to or failure of this appliance, including discoloration or surface rust, caused by the use of detergents, cleaners, chemicals or utensils other than those recommended in all instructions supplied with the product.
8. Damage to or failure of parts or systems resulting from unauthorized modifications made to this appliance.
9. Service to an appliance if the model and serial plate is missing, altered, or cannot easily be determined to have the appropriate certification logo.

#### **Disclaimer of implied warranties; limitation of remedies**

Customer's sole and exclusive remedy under this limited warranty shall be product repair or replacement as provided herein. Implied warranties, including warranties of merchantability or fitness for a particular purpose, are limited to one year on the appliance and for as long as used on the storage bins, or the shortest period allowed by law. Seller shall not be liable for incidental or consequential damages. Some states do not allow the exclusion or limitation of incidental or consequential damages, or limitation on the duration of implied warranties of merchantability or fitness, so these exclusions or limitations may not apply to you.

This warranty applies only while this appliance is used in the United States.

This warranty gives you specific legal rights, and you may also have other rights which vary from state to state.

**Transform SR Brands Management LLC, Hoffman Estates, IL 60179**

## PRODUCT RECORD

In the space below, record the date of purchase, model and serial number of your product. You will find the model and serial number printed on an identification label located on the interior liner of the refrigerator compartment. Have these items of information available whenever you contact Sears concerning your product.

Model No. \_\_\_\_\_

Date of Purchase \_\_\_\_\_

Serial No. \_\_\_\_\_

Save these instructions and attach your sales receipt for future reference.

# IMPORTANT SAFETY INSTRUCTIONS

## BASIC SAFETY PRECAUTIONS

This guide contains many important safety messages. Always **read and obey** all safety messages.



This is the safety alert symbol. It alerts you to safety messages that inform you of hazards that can kill or hurt you or others, or cause damage to the product.

All safety messages will be preceded by the safety alert symbol and the hazard signal word DANGER, WARNING or CAUTION. These words mean:

### **DANGER**

You will be killed or seriously injured if you do not follow instructions.

### **WARNING**

You will be killed or seriously injured if you do not follow instructions.

### **CAUTION**

Indicates an imminently hazardous situation which, if not avoided, may result in minor or moderate injury, or product damage.

All safety messages will identify the hazard, tell you how to reduce the chance of injury, and tell you what can happen if the instructions are not followed.

## **WARNING**

**To reduce the risk of fire, electric shock, or personal injury when using your product, basic safety precautions should be followed, including the following.**

**Read all instructions before using this appliance.**

- NEVER unplug your refrigerator by pulling on the power cord. Always grip the plug firmly and pull it straight out from the outlet.
- If the supply cord is damaged, it must be replaced by the manufacturer or its service agent or a similarly qualified person in order to avoid a hazard. Do not use a cord that shows cracks or abrasion damage along its length or at either the plug or connector end.
- Do not modify or extend the power cord length. It could cause electric shock or fire.
- When moving your refrigerator away from the wall, be careful not to roll over or damage the power cord.
- DO NOT store or use gasoline or other flammable vapors and liquids in the vicinity of this or any other appliance.
- If connected to a circuit protected by fuses, use time delay fuse.
- DO NOT allow children to climb, stand, or hang on the refrigerator doors or shelves in the refrigerator. They could damage the refrigerator and seriously injure themselves.

- Keep fingers out of pinch point areas; clearances between the doors and cabinets are necessarily small. Be careful closing doors when children are in the area.
- Unplug your refrigerator before cleaning or making any repairs.
- This appliance is not intended for use by persons (including children) with reduced physical, sensory or mental capabilities, or lack of experience and knowledge, unless they have been given supervision or instruction concerning the use of the appliance by a person responsible for their safety.
- Keep ventilation openings, in the appliance enclosure or in the built-in structure, clear of obstruction.
- Do not use mechanical devices or other means to accelerate the defrosting process, other than those recommended by the manufacturer.
- Do not damage the refrigerant circuit.
- Do not use electrical appliances inside the food storage compartments of the appliance, unless they are of the type recommended by the manufacturer.
- The refrigerant and insulation blowing gas used in the appliance require special disposal procedures. When disposing, please consult with service agent or a similarly qualified person.

**NOTE:** It is strongly recommended that any service be performed by a qualified technician.

## SAVE THESE INSTRUCTIONS

## ⚠ WARNING

- Before replacing a burned-out or broken light bulb, unplug the refrigerator or turn off power at the circuit breaker or fuse box in order to avoid contact with a live wire filament. (A burned-out light bulb may break when being replaced exposing the wire filament.)

**NOTE:** Some models have LED interior lighting and service should be performed by a qualified technician.

**WARNING:** Setting either or both controls to the OFF position does not remove power to the light circuit.

- When you are finished, reconnect the refrigerator to the electrical source and reset the controls (Thermostat, Refrigerator Control, and or Freezer Control, depending on the model) to the desired setting.
- This refrigerator must be properly installed in accordance with the **Attention Installer Instructions** that were taped to the front of the refrigerator.
- After your refrigerator is in operation, do not touch the cold surfaces in the freezer compartment when hands are damp or wet. Skin may adhere to the extremely cold surfaces.
- DO NOT touch the automatic ice making mechanism while the refrigerator is plugged in.

- DO NOT refreeze frozen foods which have thawed completely. The United States Department of Agriculture in Home and Garden Bulletin No. 69 says:

...You may safely refreeze frozen foods that have thawed if they still contain ice crystals or if they are still cold—below 39°F (4°C).

...Thawed ground meats, poultry or fish that have any off-odor or off-color should not be refrozen and should not be eaten. Thawed ice cream should be discarded. If the odor or color of any food is poor or questionable, dispose of it. The food may be dangerous to eat.

Even partial thawing and refreezing reduces the eating quality of foods, particularly fruits, vegetables and prepared foods. The eating quality of red meats is affected less than that of many other foods. Use refrozen foods as soon as possible to save as much of their quality as you can.

- This product is not to be used for special purposes such as the storage of medicine or test materials or for use on ships, etc.
- Do not strike or apply excessive force to any glass surface. Do not touch glass surfaces if they are cracked or broken.



This appliance contains a small amount of isobutane refrigerant (R600a), which is combustible. When transporting and installing the appliance, care must be taken to ensure that no parts of the refrigerating circuit are damaged. Refrigerant squirting out of the pipes could ignite or cause an eye injury. If a leak is detected, avoid any naked flames or potential sources of ignition and open room doors or windows for several minutes to allow fresh air to flow into the room.

In order to avoid the creation of a flammable gas air mixture if a leak in the refrigerating circuit occurs, the size of the room in which the appliance is installed depends on the amount of refrigerant used. The room must be 10.8 square feet (1 square meter) in size for every 8g of R600a refrigerant inside the appliance. The amount of refrigerant in your particular appliance is shown on the identification plate inside the appliance. Never start up an appliance showing any signs of damage. If in doubt, consult your dealer.

## SAVE THESE INSTRUCTIONS

## ⚠ DANGER: RISK OF CHILD ENTRAPMENT

Junked or abandoned refrigerators are dangerous, even if they are sitting for only a few days. If you are getting rid of your old refrigerator, please follow the instructions at right to help prevent accidents (child entrapment and suffocation).



### BEFORE YOU THROW AWAY YOUR OLD REFRIGERATOR OR FREEZER:

- Take off the doors.
- Leave the shelves in place so that children may not easily climb inside.

## CFC/HCFC DISPOSAL

Your old refrigerator may have a cooling system that used CFCs or HCFCs (chlorofluorocarbons or hydrochlorofluorocarbons). CFCs and HCFCs are believed to harm stratospheric ozone if released to the atmosphere. Other refrigerants may also cause harm to the environment if released to the atmosphere.

If you are throwing away your old refrigerator, make sure the refrigerant is removed for proper disposal by a qualified technician. If you intentionally release refrigerant, you may be subject to fines and imprisonment under provisions of environmental legislation.

## ELECTRICAL & GROUNDING REQUIREMENTS

**IMPORTANT:** Please read carefully.  
**TO CONNECT ELECTRICITY**

### **⚠ WARNING**

#### **Electrical Shock Hazard**

**FOR PERSONAL SAFETY**, this appliance must be properly grounded. Have the wall outlet and the circuit checked by a qualified electrician to make sure the outlet is properly grounded.

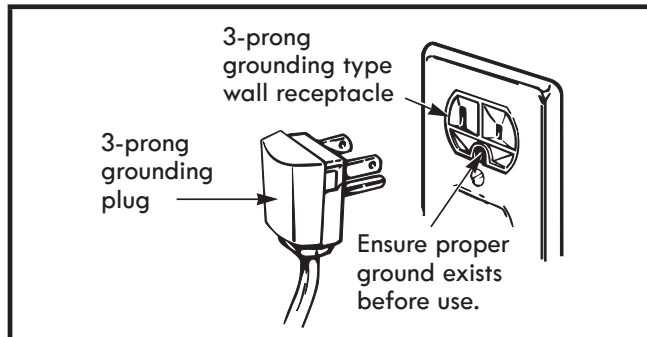

### **RECOMMENDED GROUNDING METHOD**

The refrigerator should always be plugged into its own individual properly grounded electrical outlet rated for 115 Volts, 60 Hz, AC only, and fused at 15 or 20 amperes. This provides the best performance and also prevents overloading house wiring circuits which could cause a fire hazard from overheated wires. It is recommended that a separate circuit serving only this appliance be provided.

Use a receptacle that cannot be turned off with a switch or pull chain. Do not use an extension cord.

Where a standard two-prong wall outlet is encountered, it is your personal responsibility and obligation to have it replaced with a properly grounded three-prong wall outlet.

### **USE OF EXTENSION CORDS**

**Because of potential safety hazards under certain conditions, the use of an extension cord is not recommended.** However, if you still elect to use an extension cord, it is absolutely necessary that it be a UL-listed (USA), 3-wire grounding type appliance extension cord having a grounding type plug and outlet, and that the electrical rating of the cord be 15 amperes (minimum) and 120 volts.

Use of an extension cord will increase the clearance needed for the back of the refrigerator.

# PARTS AND FEATURES

## • PreView Grab-N-Go Model

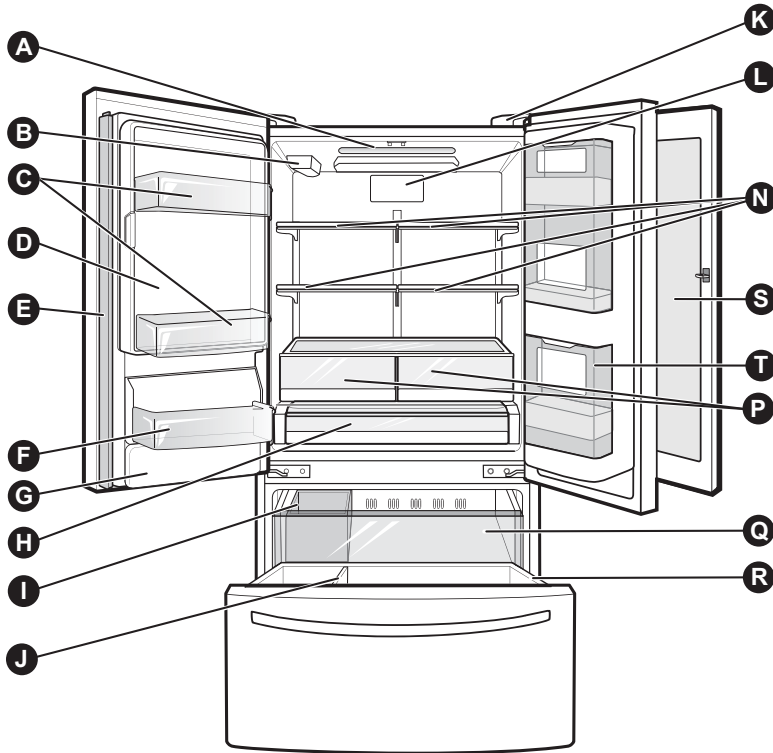

Use this page to become more familiar with the parts and features of your refrigerator.

**NOTE:** This guide covers several different models. The refrigerator you have purchased may have some or all of the items listed below. The locations of the features shown below may not match your model.

- A** Refrigerator Light
- B** Water Filter
- C** Door Bins
- D** Ice Compartment (Icemaker and Ice Bin)
- E** Articulating Mullion
- F** Fixed Door Bins
- G** Water Tank Cover
- H** Pantry Drawer
- I** Extra Ice Bin
- J** Durabase Divider
- K** Diagnostics Speaker
- L** Air Filter
- M** Dairy Bin
- N** Refrigerator Shelves
- O** Modular Door Bin
- P** Crisper
- Q** Pullout Drawer
- R** Durabase
- S** PreView Grab-N-Go
- T** Grab-N-Go Case

## • Standard model

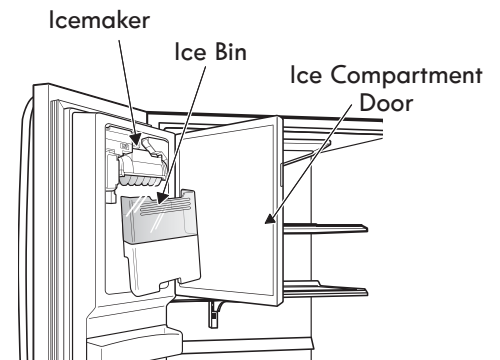
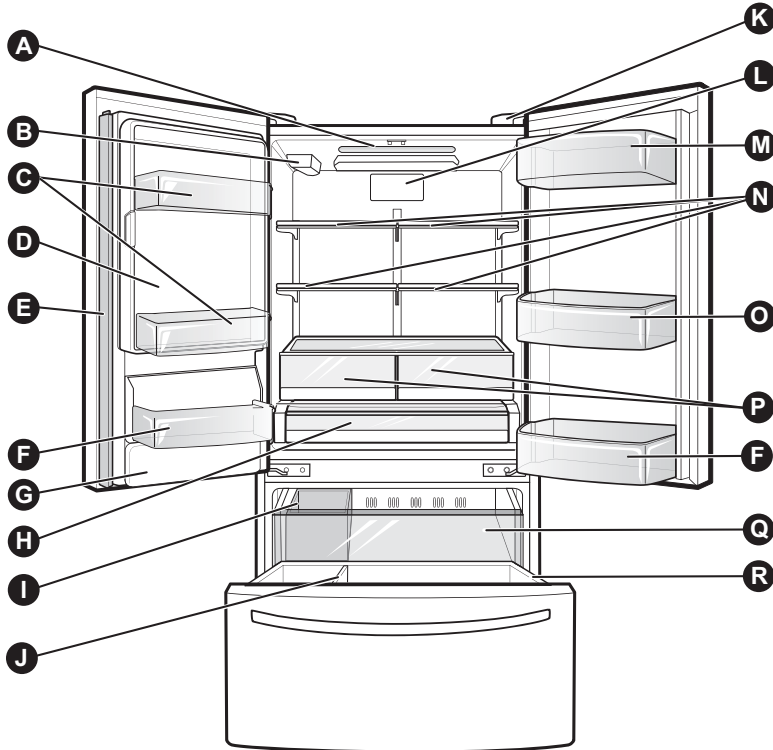



# REFRIGERATOR INSTALLATION

## ⚠ WARNING

### Excessive Weight Hazard:

Use two or more people to move and install the refrigerator. Failure to do so can result in back or other injury.

## UNPACKING YOUR REFRIGERATOR

Remove tape and any temporary labels from your refrigerator before using. Do not remove any warning-type labels, the model and serial number label, or the Tech Sheet that is located under the front of the refrigerator.

To remove any remaining tape or glue, rub the area briskly with your thumb. Tape or glue residue can also be easily removed by rubbing a small amount of liquid dish soap over the adhesive with your fingers. Wipe with warm water and dry.

Do not use sharp instruments, rubbing alcohol, flammable fluids, or abrasive cleaners to remove tape or glue. These products can damage the surface of your refrigerator.

Refrigerator shelves are installed in the shipping position. Please reinstall shelves according to your individual storage needs.

## ⚠ WARNING

### Excessive Weight Hazard:

Your refrigerator is heavy. When moving the refrigerator for cleaning or service, be sure to protect the floor. Always pull the refrigerator straight out when moving it. Do not wiggle or walk the refrigerator when trying to move it, as floor damage could occur.

## ⚠ WARNING

### Explosion Hazard:

Keep flammable materials and vapors, such as gasoline, away from the refrigerator. Failure to do so can result in fire, explosion, or death.

## DIMENSIONS AND CLEARANCES

- Check the dimensions of the appliance and the installation path to ensure there is sufficient room to move the refrigerator through doors or narrow openings.
- If an opening is too narrow to fit the refrigerator through, remove the refrigerator doors. See Removing and Replacing Refrigerator Doors in this manual.
- The installation location chosen for the refrigerator should allow space behind the unit for connections and airflow and space in front to open the doors and drawers.
- Too small of a distance from adjacent items may result in lowered freezing capability and increased electricity consumption charges. Allow at least 27 inches (686 mm) in front of the refrigerator to open the doors, and at least 2 inches (51 mm) between the back of the refrigerator and the wall.

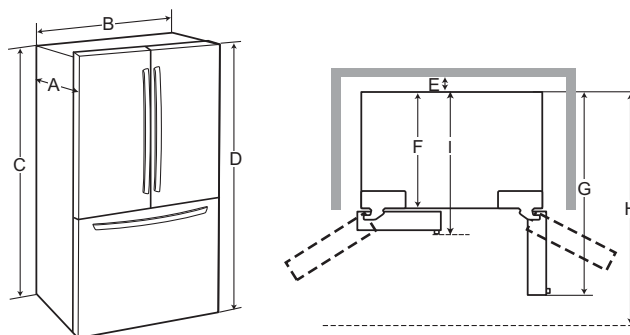

	Model	7135#	7035#
A	Depth without handle	32 3/8" (822 mm)	28 3/4" (728 mm)
B	Width	35 3/4" (908 mm)	35 3/4" (908 mm)
C	Height to Top of Case	68 3/8" (1737 mm)	68 3/8" (1737 mm)
D	Height to Top of Hinge	69 3/4" (1772 mm)	69 3/4" (1772 mm)
E	Back Clearance	2" (50 mm)	2" (50 mm)
F	Depth without Door	28 1/2" (724 mm)	24 3/4" (630 mm)
G	Depth (Total with Door Open 90°)	47 1/8" (1197 mm)	43 1/2" (1103 mm)
H	Depth (Total with Freezer Door Open)	56 19/64" (1430 mm)	48 27/64" (1230 mm)
I	Depth with handle	34 7/8" (886 mm)	31 1/4" (792 mm)

## REFRIGERATOR INSTALLATION

### INSTALLATION

The refrigerator should always be plugged into its own individual properly grounded electrical outlet rated for 115 Volts, 60 Hz, AC only, and fused at 15 or 20 amperes. This provides the best performance and also prevents overloading house wiring circuits which could cause a fire hazard from overheated wires. It is recommended that a separate circuit serving only this appliance be provided.

This appliance is intended to be used in household and similar applications such as staff kitchen areas in shops, offices and other working environments; farm houses and by clients in hotels, motels and other residential type environments; bed and breakfast type environments; catering and similar non-retail applications.

### **! WARNING**

#### **Shock Hazard:**

To reduce the risk of electric shock, do not install the refrigerator in a wet or damp area.

1. To avoid noise and vibration, the unit must be leveled and installed on a solidly constructed floor. If required, adjust the leveling legs to compensate for unevenness of the floor. The front should be slightly higher than the rear to aid in door closing. Leveling legs can be turned easily by tipping the cabinet slightly. Turn the leveling legs to the left to raise the unit or to the right to lower it. (See LEVELING AND DOOR ALIGNMENT.)

**NOTE:** Installing on carpeting, soft tile surfaces, a platform or weakly supported structure is not recommended.

2. Install this appliance in an area where the temperature is between 55°F (13°C) and 110°F (43°C). If the temperature around the appliance is too low or high, cooling ability may be adversely affected.
3. Select a place where a water supply can be easily connected for the automatic icemaker.

**NOTE:** The water pressure must be from 20-120 psi or 138-827 kPa or 1.4-8.4 kgf/cm<sup>2</sup>. If the refrigerator is installed in an area with low water pressure (below 20 psi), you can install a booster pump to compensate for the low pressure.

4. Too small of a distance from adjacent items may result in lowered freezing capability and increased electricity consumption charges. Allow at least 24 inches (61 cm) in front of the refrigerator to open the doors and at least 2 inches (5.08 cm) between the back of the refrigerator and the wall.

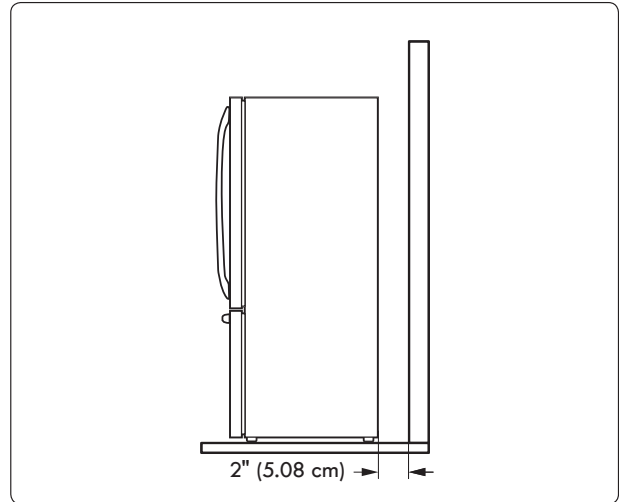

### PRIOR TO USE

1. Clean your refrigerator thoroughly and wipe off all dust that accumulated during shipping.
2. Install accessories such as ice cube bin, drawers, shelves, etc., in their proper places. They are packed together to prevent possible damage during shipment.
3. Allow your refrigerator to run for at least two to three hours before putting food in it. Check the flow of cold air in the freezer compartment to ensure proper cooling. Your refrigerator is now ready for use.

**NOTE:** Removing the doors is always recommended when it is necessary to move the refrigerator through a narrow opening. If it is necessary to remove the handles, follow the directions below.

## REMOVING AND REPLACING HANDLES

**NOTE:** Handle appearance may vary from the illustrations on this page.

### Removing Refrigerator Handle

Loosen the set screws with a  $\frac{3}{32}$  in. Allen wrench and remove the handle.

**NOTE:** If the handle mounting fasteners need to be tightened or removed, use a  $\frac{1}{4}$  in. Allen wrench.

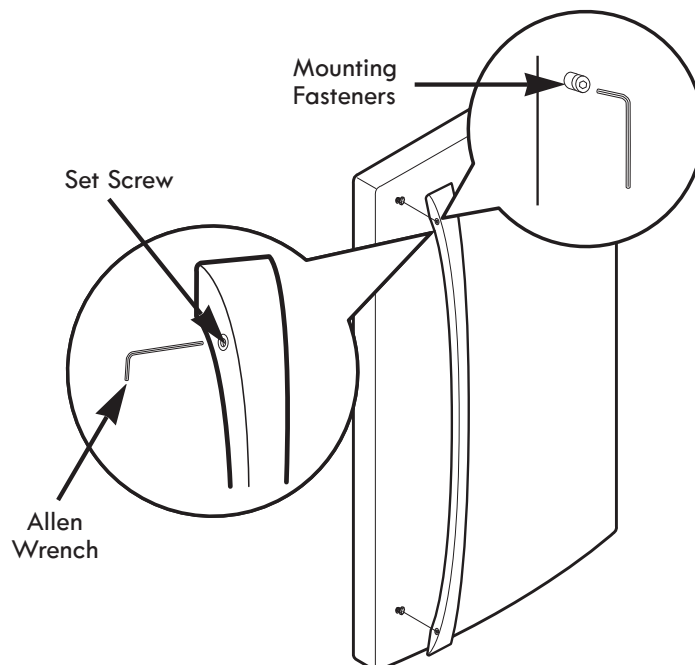

### Replacing Refrigerator Handle

Place the handle on the door by fitting the handle footprints over the mounting fasteners and tightening the set screws with a  $\frac{3}{32}$  in Allen wrench.

**NOTE:** If the handle mounting fasteners need to be tightened or removed, use a  $\frac{1}{4}$  in. Allen wrench.

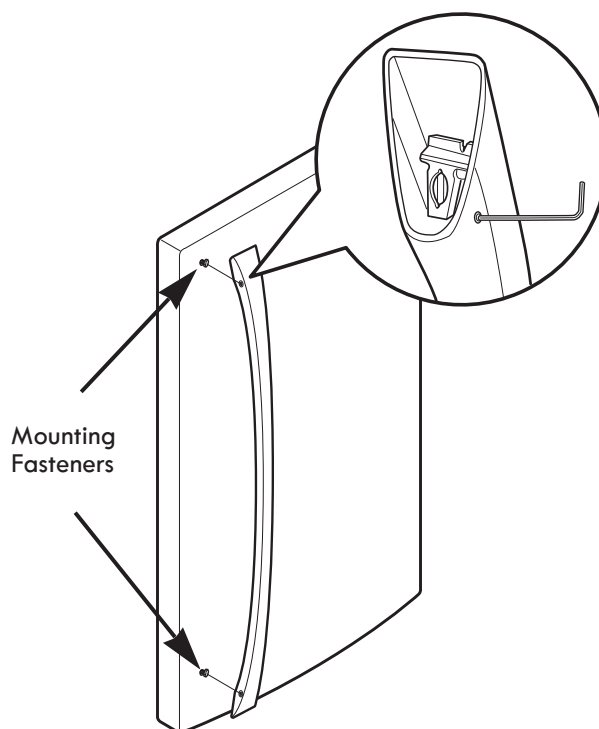

## REFRIGERATOR INSTALLATION

**NOTE:** Removing the doors is always recommended when it is necessary to move the refrigerator through a narrow opening. If it is necessary to remove the handles, follow the directions below.

### REMOVING AND REPLACING HANDLES (CONTINUED)

**NOTE:** Handle appearance may vary from the illustrations on this page.

#### Removing Freezer Drawer Handle

Loosen the set screws located on the lower side of the handle with a  $\frac{1}{8}$  in. Allen wrench and remove the handle.

**NOTE:** If the handle mounting fasteners need to be tightened or removed, use a  $\frac{1}{4}$  in. Allen wrench.

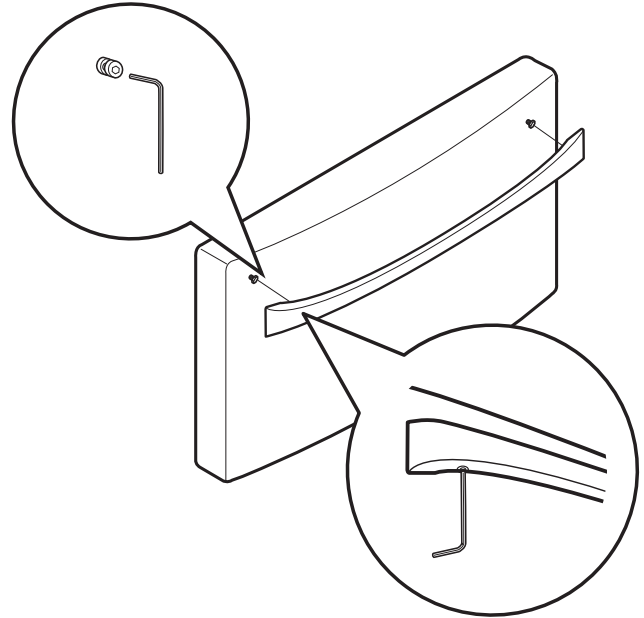

#### Replacing Freezer Drawer Handle

Place the handle on the door by fitting the handle footprints over the mounting fasteners and tightening the set screws with a  $\frac{1}{8}$  in. Allen wrench.

**NOTE:** If the handle mounting fasteners need to be tightened or removed, use a  $\frac{1}{4}$  in. Allen wrench.

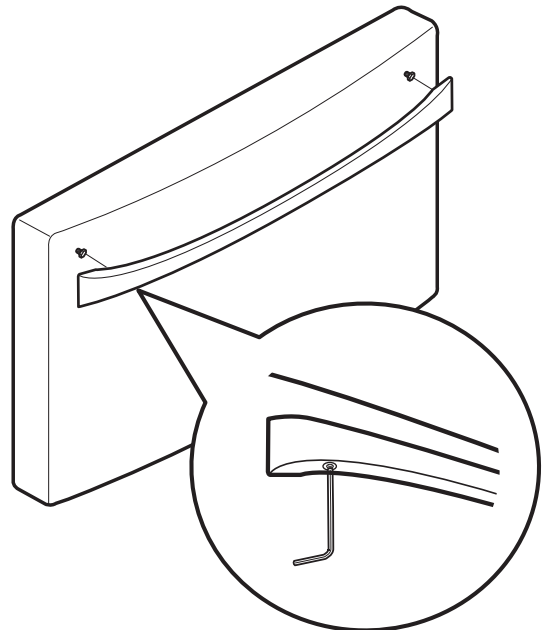

## WARNING

When assembling or disassembling the handles:

- Grasp the handle firmly to ensure it will not drop or cause injury.
- Prevent the handle from swinging toward nearby people or animals.
- Insert the bracket hole of the handle into the stopper bolt of the door exactly, then assemble the set screws to fix the handle in place.
- Check for any gap between the door and handle after the handle is fixed in place.

## REMOVING AND REPLACING REFRIGERATOR DOORS

### ⚠ WARNING

#### Excessive Weight Hazard:

Use two or more people to remove and install the refrigerator doors. Failure to do so can result in back or other injury.

### ⚠ WARNING

#### Electrical Shock Hazard

- Disconnect the electrical supply to the refrigerator before installing. Failure to do so could result in serious injury or death.
- Do not put hands, feet or other objects into the air vents or bottom of the refrigerator. You may be injured or receive an electrical shock.

### Removing the Left Door

1. The water supply is connected to the upper right part of the rear surface of the refrigerator. Remove the ring in the joint area. Hold the water supply connection and gently push the collet (1) to detach the water supply line (2) as shown.

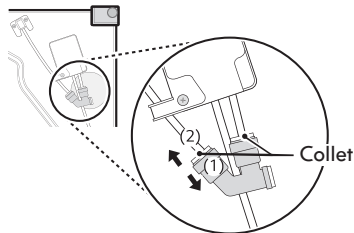

2. Remove the screw (1) from the hinge cover at the top of the refrigerator. Lift the hook (not visible), located at the bottom of the front side of the cover (2) with a flat-head screwdriver.

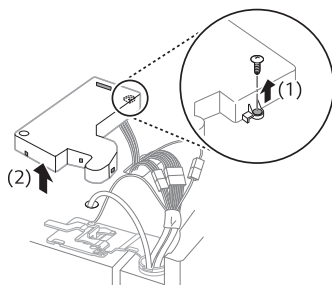

3. Remove the cover and pull out the tube (1). Disconnect all wire harnesses (2). Unscrew the ground wire (3).

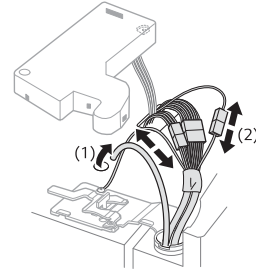

4. Rotate the hinge lever counterclockwise (1). Lift the top hinge (2) free of the hinge lever latch.

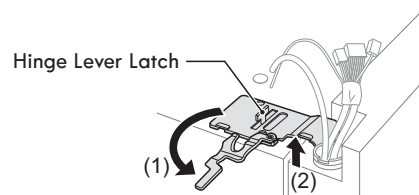

### ⚠ CAUTION

- When lifting the hinge free of the latch, be careful that the door does not fall forward.

5. Lift the door from the middle hinge pin and remove the door.

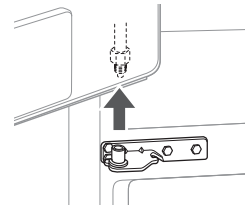

**NOTE:** Place the door, inside facing up, on a nonscratching surface.

### NOTE Disassembling/Assembling the Water Lines

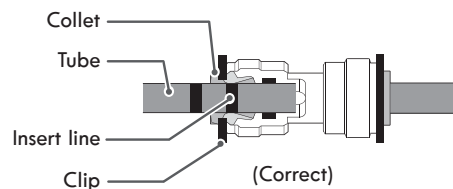

## REFRIGERATOR INSTALLATION

### Removing the Right Door

1. Remove the top hinge cover screw (1). Lift the hook (not visible), located at the bottom of the front side of the cover (2), with a flat-head screwdriver.

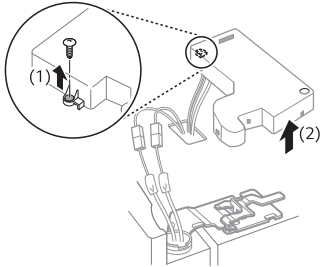

2. Detach the wire harness (1).

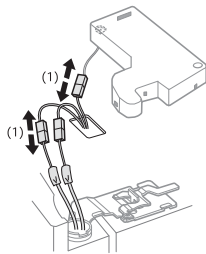

3. Rotate the hinge lever (1) clockwise. Lift the top hinge (2) free of the hinge lever latch.

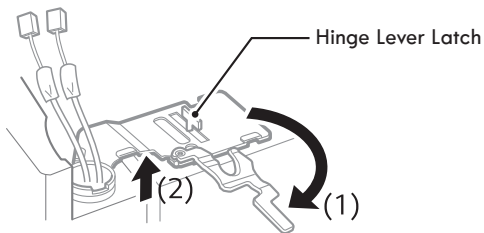

### CAUTION

- When lifting the hinge free of the latch, be careful that the door does not fall forward.

4. Lift the door from the middle hinge pin and remove the door.

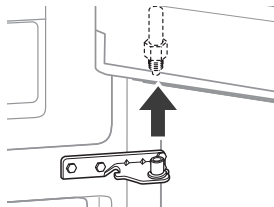

**NOTE:** Place the door, inside facing up, on a nonscratching surface.

### Replacing the Right Door

Install the right-side door first.

1. Make sure that the plastic sleeve is inserted in the bottom of the door. Lower the door onto the middle hinge pin as shown in the figure.

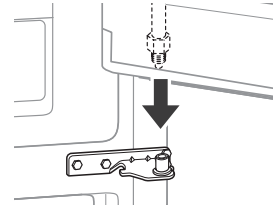

2. Fit the hinge (1) over the hinge lever latch and slot it into place. Rotate the lever (2) counterclockwise to secure the hinge.

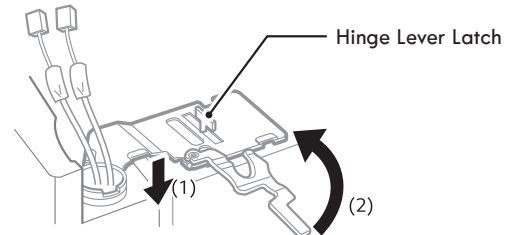

3. Connect the wire harness (1).

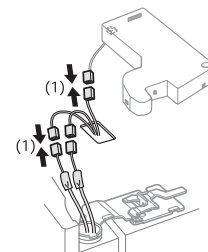

4. Place the cover (1) in its place. Insert and tighten the cover screw (2).

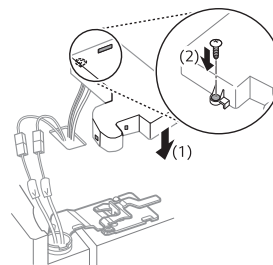

### Replacing the Left Door

Install the left refrigerator door after the right door is installed.

1. Make sure that the plastic sleeve is inserted in the bottom of the door. Install the refrigerator door onto the middle hinge.

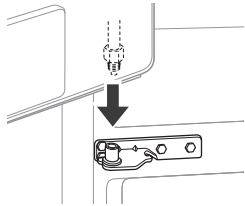

2. Fit the hinge (1) over the hinge lever latch and slot it into place. Rotate the lever clockwise (2) and fasten the hinge.

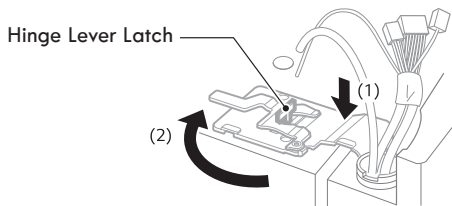

3. Connect all the wire harnesses.

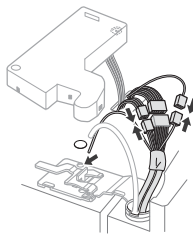

4. Push the water supply tube into the hole on the top case and pull it through the backplate.

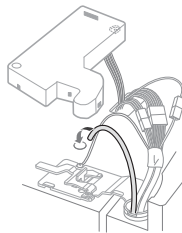

5. Hold the water supply connection and gently push in the collet (1) to connect the water supply line (2) as shown. Insert the tube at least 5/8 inch (15 mm) into the connector. Insert the clip on the joint to fasten the tube in place.

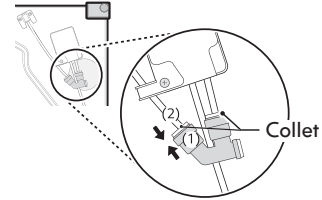

6. Place the cover (1) in place. Insert and tighten the cover screw (2).

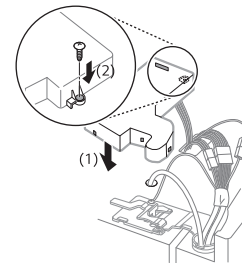

### NOTE Disassembling/Assembling the Water Lines

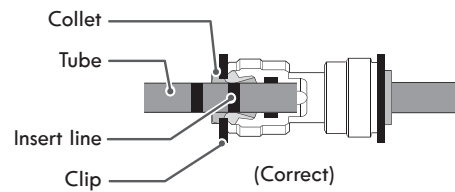

- Gently press the collet and insert the tube until only one line shows on the tube.

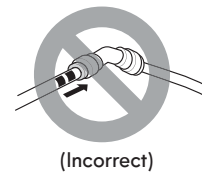
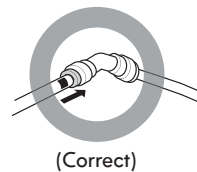

## REFRIGERATOR INSTALLATION

### REMOVING FREEZER DRAWERS

**⚠ WARNING:** Use two or more people to remove and install the freezer drawer. Failure to do so can result in back or other injury.

**NOTE:** In the following figures, the Pullout Drawer located above the freezer drawer is not shown for clarity.

#### Removing The Freezer Drawer

Pull the drawer open to full extension.  
Gently lift and pull out the ice bin.

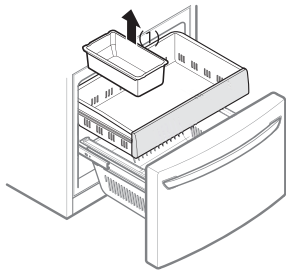

Lift the front of the drawer up, then pull it straight out.

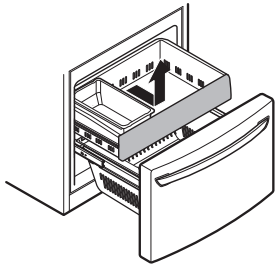

Remove the Durabase basket from the rails.  
Remove the screws from the rails at both ends.

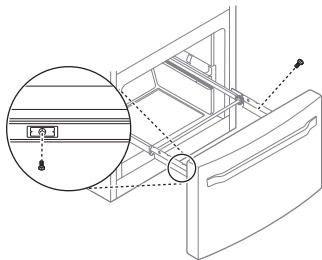

Grip both sides of the drawer and pull it up to remove it from the rails.

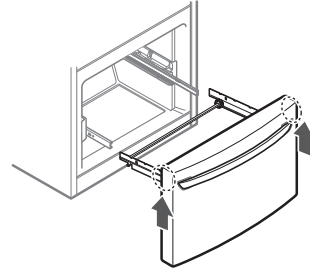

#### ⚠ CAUTION:

When you remove the freezer drawer, do not hold the handle. The handle may come off and it could cause personal injury.

Hold both rails and push them in simultaneously.

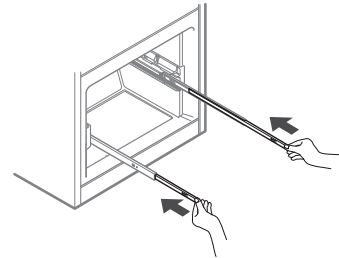



## REPLACING FREEZER DRAWERS

**⚠ WARNING:** Use two or more people to remove and install the freezer drawer. Failure to do so can result in back or other injury.

**NOTE:** In the following figures, the Pullout Drawer located above the freezer drawer is not shown for clarity.

### Replacing The Freezer Drawer

Pull out both rails simultaneously, until they are fully extended.

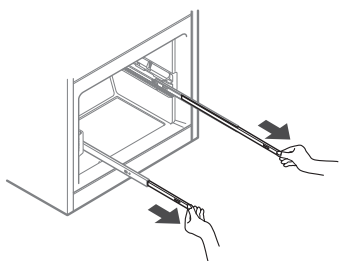

Grasp the drawer on each side and hook the drawer supports into the rail tabs located on both sides.

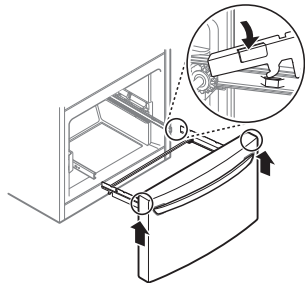

Lower the door into its final position and tighten the screws located on both sides.

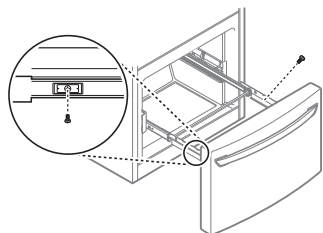

Push the drawer back until it clicks into place.

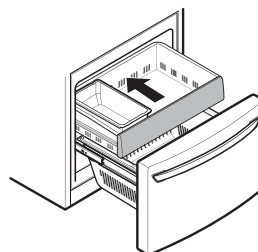

Replace the ice bin in the drawer. Insert the Durabase basket in the rail assembly.

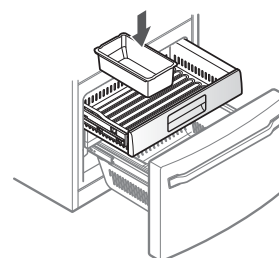

### ⚠ WARNING

- If the Durabase divider is removed, there is enough open space for children or pets to crawl inside. To prevent accidental child and pet entrapment or suffocation risk, **DO NOT** allow them to touch or go near the freezer drawer.
- **DO NOT** step or sit down on the freezer drawer.

## REFRIGERATOR INSTALLATION

### LEVELING AND DOOR ALIGNMENT

#### Leveling

After installing, plug the refrigerator's power cord into a 3-prong grounded outlet and push the refrigerator into the final position.

Your refrigerator has two front leveling legs—one on the right and one on the left. Adjust the legs to alter the tilt from front-to-back or side-to-side. If your refrigerator seems unsteady, or you want the doors to close more easily, adjust the refrigerator's tilt using the instructions below:

**NOTE:** Tools Required:  $\frac{1}{16}$ " wrench or flat blade screwdriver.

1. Turn the leveling leg to the left to raise that side of the refrigerator or to the right to lower it. It may take several turns of the leveling leg to adjust the tilt of the refrigerator.

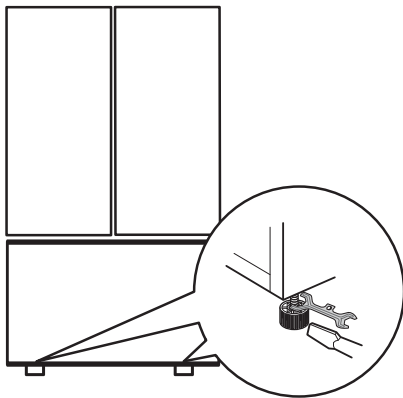

**NOTE:** Having someone push backward against the top of the refrigerator takes some weight off of the leveling legs. This makes it easier to adjust the legs.

2. Open both doors again and check to make sure that they close easily. If the doors do not close easily, tilt the refrigerator slightly more to the rear by turning both leveling legs to the left. It may take several more turns, and you should turn both leveling legs the same amount.

**NOTE:** Your refrigerator is uniquely designed with two fresh food doors. Either door can be opened or closed independently of the other. You may have to exert slight pressure on the doors to get them to close completely.

#### Door Alignment

The left refrigerator door has an adjustable nut, located on the bottom hinge, to raise and lower the door for proper alignment.

If the space between your doors is uneven, follow the instructions below to align the doors.

Use the wrench (included with the Use & Care Guide) to turn the nut in the door hinge to adjust the height. Turn the nut right to raise the door or left to lower it.

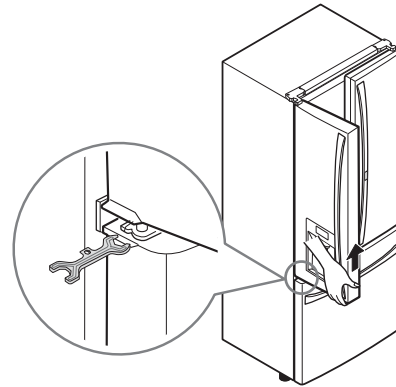

# USING YOUR REFRIGERATOR

## SETTING THE CONTROLS

### Temperature

- The Refrigerator Control is preset at 37°F (3°C) and the freezer control is preset at 0°F (-18°C). These are the recommended temperature settings for normal use and conditions. Wait 24 hours for the refrigerator and freezer to reach these temperatures.



- The Refrigerator Temp Control range is from 33°F to 43°F (1°C to 7°C). The lower the setting, the colder the refrigerator compartment will become.
- The Freezer Temp Control range is from -7°F to 5°F (-23°C to -15°C). The lower the setting, the colder the freezer compartment will become.

**NOTE:** When changing control settings, wait 24 hours before making additional adjustments. The controls are set correctly when milk or juice is as cold as you would like and when ice cream is firm. If the temperature in either compartment is too cold or too warm, change the setting one increment at a time. Wait 24 hours for the change to stabilize before adjusting again.

### Ice / Water

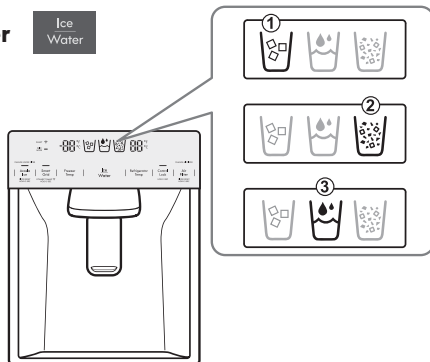

The dispenser dispenses water, cubed ice, or crushed ice. Press the Ice/Water button repeatedly to illuminate the icon for the desired dispenser mode.

**NOTE:** The dispenser will not operate when either of the refrigerator doors is open.

**NOTE:** If the Control Lock LED icon is illuminated, the dispenser will not work. Disable the Control Lock to use the dispenser again.

### ⚠ CAUTION

- The control display is operated by touch. Excessive moisture on the display may cause a malfunction. Please keep the display clean and dry.
- Connect to potable water supply only.

### Airflow

Be sure not to block vents while loading food into the refrigerator. Doing so will restrict airflow and may cause the refrigerator temperature to become too warm or cause interior moisture buildup. (See airflow diagram below.)

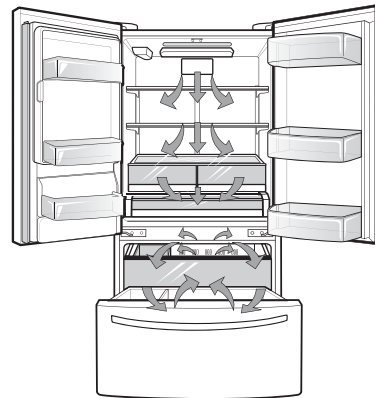

### Accela Ice



- When you touch the Accela Ice button, the LED will light up and will remain on for 24 hours. The function will automatically shut off after 24 hours.
- You can stop this function manually by touching the button one more time.
- This function increases both ice making and freezing capabilities.

### Water Filter Reset



When the "Change Water Filter" text lights up, change the water filter. After changing the water filter, press and hold  button for three seconds to turn the indicator light off. You need to change the water filter approximately every six months.

## USING YOUR REFRIGERATOR

### Air Filter



The Air Filter helps remove odors from the refrigerator. The Air Filter will cycle on and off in increments of ten minutes on and 110 minutes off.

### Air Filter Reset



When the "Change Air Filter" text lights up, replace the air filter. After replacing the air filter, press and hold the Air Filter button for 3 seconds to turn the LED off. Replace the air filter approximately every 6 months.

### Control Lock



- When power is initially connected to the refrigerator, the Lock function is off.
- To lock the control panel and dispenser, press and hold the Control Lock button for 3 seconds or until the LED turns on.
- To unlock the controls and dispenser, press and hold the Control Lock button until the LED turns off.

### Demo Mode (For Store Use Only)

The Demo Mode disables all cooling in the refrigerator and freezer sections to conserve energy while on display in a retail store. When activated, OFF will display on the control panel.



#### To deactivate:

With either refrigerator door opened, press the Accela Ice button 3 times consecutively while pressing the Refrigerator Temp button. The control panel beeps and the temperature settings display to confirm that Demo Mode is deactivated. Use the same procedure to activate the Demo Mode.

### Temperature Mode Switch Function (°F <->°C)

If you want to convert °F to °C or vice versa, press and hold the Freezer Temp and Refrigerator Temp buttons at the same time for approximately five seconds.

### Articulating Mullion

This feature is a metal strip attached to the left door that articulates (rotates) 90 degrees as the door is closed, forming a mullion (base) for the left and right door gaskets to seal against.

### ⚠ CAUTION

To reduce the risk of scratching the door or breaking the door mullion, make sure that the refrigerator door mullion is always folded in.

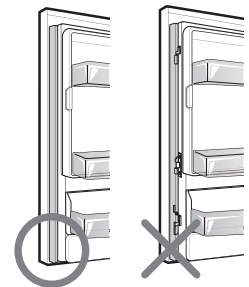

## SMART FEATURES

### OVERVIEW

Kenmore Smart connectivity transforms your relationship with your home. You can personalize the way Kenmore Smart products operate based on your schedule and daily routines, making life easier and providing greater peace of mind.

This appliance is a connected-ready appliance, allowing you to remotely monitor and control it from your smart phone via the Kenmore Smart™ app. .

To get started, you will need the following:

- Kenmore Smart™ Appliance
- Wi-Fi home router connected to the internet
- Smart phone
- Kenmore Smart™ app

For more information about your Kenmore Smart™ appliance, please visit [www.Kenmore.com/smart](http://www.Kenmore.com/smart).

The Smart Grid function controls energy usage, which helps you save energy during peak usage periods. You can override the SMART GRID function at any time (using the Smart Grid button or application).

Smart Grid responds to notification events from your utility company to run high energy-consuming tasks only during off-peak times when electrical demand is lower. These notification events are known as Demand Response (DR) signals. If the refrigerator receives a DR signal from the utility company, the refrigerator will turn on the GRID MODE LED on the refrigerator control panel and regulate power consumption according to the signal received. The refrigerator will respond to the signals received from the utility company as long as the appliance is connected to the internet and Smart Grid is enabled.

### DEFINITIONS

SMART LED (white): 

Notifies the user that the appliance is connected to the internet.

Smart Grid LED (white): 

Notifies the user that the appliance is capable of receiving a signal, known as a Demand Response event, from a utility company's energy management system.

GRID MODE LED (red): 

Notifies the user that the appliance is reducing or delaying energy use based on the signal received from a utility company energy management system. The LED will remain illuminated during critical peak pricing (CPP) and real time pricing (RTP) or during a high demand for electricity.

### GETTING CONNECTED

You need the following devices and application to use the Smart Grid and other smart features on your refrigerator.

Required Devices: A wireless router, Kenmore Smart Refrigerator, and a mobile device.

Required Application: Kenmore Smart App.

### CONNECTING THE REFRIGERATOR

Refer to the Quick Start Guide that came with your smart appliance for detailed instructions on creating a Kenmore account and setting up the appliance for connected operation from your mobile device. For additional assistance, visit <http://www.kenmore.com/smart>

**NOTE:** When successfully connected to the internet, the SMART icon LED on the unit control panel will turn ON.

### INSTRUCTIONS FOR SMART GRID

#### IMPORTANT:

You must connect your Kenmore Smart appliance to the internet and then register the appliance to your account in order to use the Smart Grid function.

Consult the Quick Start Guide supplied with the appliance for instructions on how to register your appliance using the Kenmore Smart™ application (app).

To use the Smart Grid function, you need to register your application with your electric utility company, provided that your electric utility company supports the function. In other words, the Smart Grid function will not be available if your electric utility company does not support the function or does not have the capability to support the function.

The Smart Grid Button serves two purposes:  
1) internet connection or disconnection, 2) enable or disable/override the appliance Demand Response capability.

**NOTE:** This appliance is a connected-ready appliance, allowing you to remotely monitor and control it from your smart phone via the Kenmore Smart™ app.

To connect the refrigerator to the Internet:  
Refer to the Quick Start Guide that came with your smart appliance for detailed instructions on creating a Kenmore account and setting up your appliance for connected operation from your smart phone. This Use & Care Guide contains information and instructions for operating your appliance from the appliance control panel. For additional assistance, visit <http://www.kenmore.com/smart>

**NOTE:** If no connection is made after 10 minutes the blinking SMART GRID button LED will turn off.

#### Smart Grid Operation:

Once connected and registered, the appliance is capable of accepting a signal from your electrical company. The signal, known as a Demand Response (DR) signal, will adjust refrigerator operation to reduce power consumption for a period of time ranging from a few minutes up to a maximum of 4 hours. Ice making will be delayed during this time. Opening the refrigerator door may cancel certain DR signals.

The Grid Mode LED (red) will be steadily lit when the signal is in effect. To disable the signal and prevent further signal acceptance, press and release the Smart Grid button. Both the Grid Mode and Smart Grid LED will turn off. Press and release the Smart Grid button again to enable DR signal acceptance capability. The Smart Grid button LED will relight. The Grid Mode LED will light when another DR signal is sent.

**FCC Notice  
(For transmitter module contained in this product)**

This equipment has been tested and found to comply with the limits for a Class B digital device, pursuant to Part 15 of the FCC Rules. These limits are designed to provide reasonable protection against harmful interference in a residential installation. This equipment generates, uses, and can radiate radio frequency energy and, if not installed and used in accordance with the instructions, may cause harmful interference to radio communications. However, there is no guarantee that interference will not occur in a particular installation. If this equipment does cause harmful interference to radio or television reception, which can be determined by turning the equipment off and on, the user is encouraged to try to correct the interference by one or more of the following measures:

- Reorient or relocate the receiving antenna.
- Increase the separation between the equipment and the receiver.
- Connect the equipment to an outlet on a circuit different from that to which the receiver is connected.
- Consult the dealer or an experienced radio/TV technician for help.

This device complies with part 15 of the FCC Rules. Operation is subject to the following two conditions:

- 1) this device may not cause harmful interference and
- 2) this device must accept any interference received, including interference that may cause undesired operation of the device.

Any changes or modifications in construction of this device which are not expressly approved by the party responsible for compliance could void the user's authority to operate the equipment.

**Open Source Software Notice**

To obtain the source code that is contained in this product under LGPL and other open source licenses, visit <http://kenmore.com/opensource>. In addition to the source code, all referred license terms, warranty disclaimers, and copyright notices are available for download.

**FCC RF Radiation Exposure Statement**

This equipment complies with FCC radiation exposure limits set forth for an uncontrolled environment. This transmitter must not be co-located or operating in conjunction with any other antenna or transmitter. This equipment should be installed and operated with a minimum distance of 20 cm (7.8 inches) between the antenna and your body. Users must follow the specific operating instructions for satisfying RF exposure compliance.

<b>Wireless LAN Module Specifications</b>	
Model	LCW-004
Frequency Range	2412 to 2462 MHz
Output Power (Max)	< 30 dBm

## USING YOUR REFRIGERATOR

### IN-DOOR ICE BIN

#### ⚠ CAUTION

Keep hands and tools out of the ice compartment door and dispenser chute. Failure to do so may result in damage or personal injury.

The icemaker will stop producing ice when the in-door ice bin is full. If you need more ice, empty the ice bin into the extra ice bin in the freezer compartment. During use, the ice can become uneven causing the icemaker to misread the amount of ice cubes and stop producing ice. Shaking the ice bin to level the ice within it can reduce this problem.

**NOTE:** Storing cans or other items in the ice bin will damage the icemaker.

Keep the ice compartment door closed tightly. If the ice compartment door is not closed tightly, the cold air in the ice bin will freeze food in the refrigerator compartment. This could also cause the icemaker to stop producing ice.

**NOTE:** Emptying the ice bin is recommended if the icemaker ON/OFF button on the control panel is set to OFF for an extended period of time.

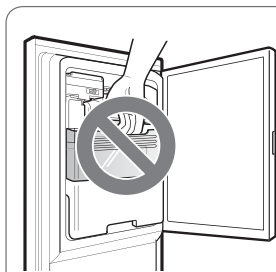

#### ⚠ CAUTION

When handling the ice bin, keep hands away from the icemaker tray area to avoid personal injury.

1. Pull or push the door handle to open or close the ice compartment.

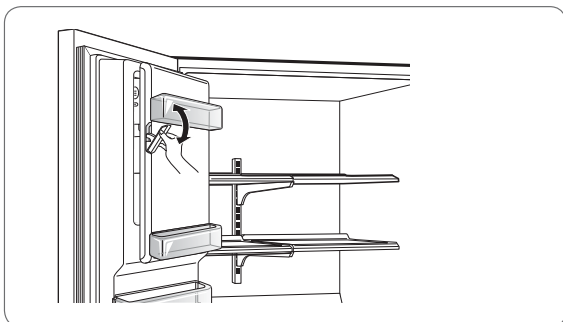

2. To remove the in-door ice bin, grip the front handle, slightly lift the lower part, and slowly pull out the bin as shown.

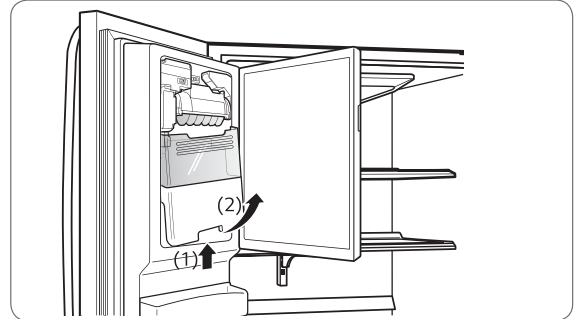

3. To reinstall the in-door ice bin, slightly slant the bin during replacement to avoid contact with the icemaker.

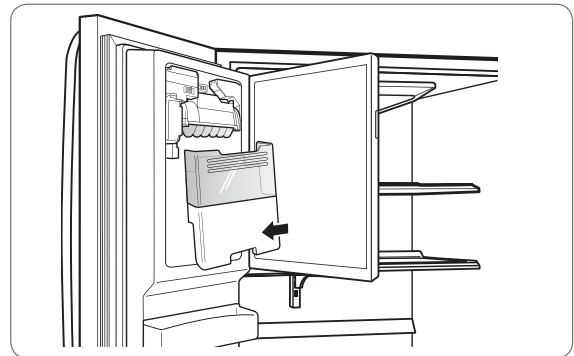

4. Avoid touching the auto shutoff (feeler arm) when replacing the ice bin. See the label on the ice compartment door for details.

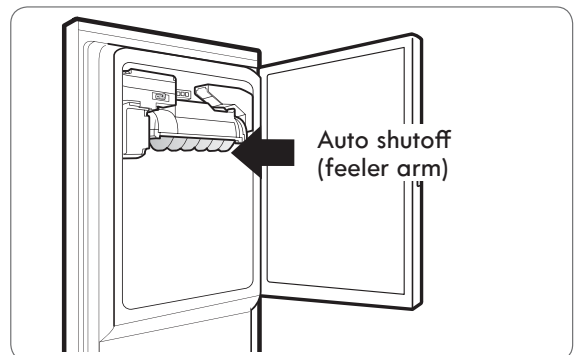



## AUTOMATIC ICEMAKER

Ice is made in the automatic icemaker and sent to the dispenser. The icemaker will produce 70-182 cubes in a 24-hour period, depending on freezer compartment temperature, room temperature, number of door openings and other operating conditions.

- It takes about 12 to 24 hours for a newly installed refrigerator to begin making ice.
- Ice making stops when the in-door ice bin is full. When full, the in-door ice bin holds approximately 6 to 8 (12-16 oz or 340-455 cc) glasses of ice.
- Foreign substances or frost on the auto shutoff (feeler arm) can interrupt ice production. Make sure the feeler arm is clean at all times for proper operation.
- To increase ice production, use the Accela Ice function. This function increases both ice making and freezing capabilities.

### **⚠ WARNING**

#### **Personal Injury Hazard**

DO NOT place fingers or hands on the automatic ice making mechanism while the refrigerator is plugged in.

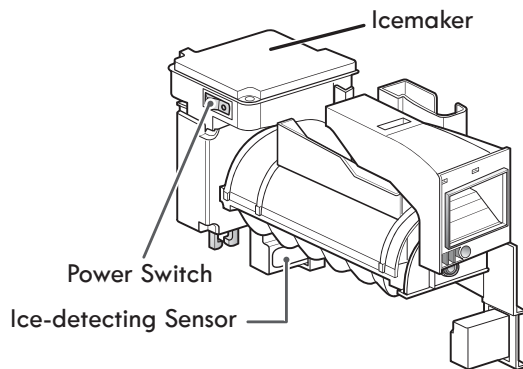

### **⚠ CAUTION**

- The first ice and water dispensed may include particles or odor from the water supply line or the water tank.
- Throw away the first few batches of ice. This is also necessary if the refrigerator has not been used for a long time.
- Never store beverage cans or other items in the ice bin for the purpose of rapid cooling. Doing so may damage the icemaker or the containers may burst.
- If discolored ice is dispensed, check the water filter and water supply. If the problem continues, contact a Sears or other qualified service center. Do not use the ice or water until the problem is corrected.
- Keep children away from the dispenser. Children may play with or damage the controls.
- The ice passage may become blocked with frost if only crushed ice is used. Remove the frost that accumulates by removing the ice bin and clearing the passage with a rubber spatula. Dispensing cubed ice can also help prevent frost buildup.
- Never use thin crystal glass or crockery to collect ice. Such containers may chip or break resulting in glass fragments in the ice.
- Dispense ice into a glass before filling it with water or other beverages. Splashing may occur if ice is dispensed into a glass that already contains liquid.
- Never use a glass that is exceptionally narrow or deep. Ice may jam in the ice passage and refrigerator performance may be affected.
- Keep the glass at a proper distance from the ice outlet. A glass held too close to the outlet may prevent ice from dispensing.
- To avoid personal injury, keep hands out of the ice door and passage.
- Never remove the dispenser cover.
- If ice or water dispenses unexpectedly, turn off the water supply and contact Sears Home Service at 1-844-553-6667.

## USING YOUR REFRIGERATOR

### AUTOMATIC ICEMAKER (continued)

#### Turning the Automatic Icemaker On or Off

To turn off the automatic icemaker, set the icemaker switch to **OFF (O)**. To turn on the automatic icemaker, set the switch to **ON (I)**.

#### Normal Sounds You May Hear

- Keeping the power turned on to the icemaker before the water line is connected can damage the icemaker.
- The icemaker water valve will buzz as the icemaker fills with water. If the power switch is in the **ON (I)** position, it will buzz even if it has not yet been hooked up to water. To stop the buzzing, move the power switch to **OFF (O)**.
- You will hear the sound of cubes dropping into the bin and water running in the pipes as the icemaker refills.

#### Preparing for Vacation

Set the icemaker power switch to **OFF (O)** and shut off the water supply to the refrigerator.

#### NOTE

- The ice bin should be emptied any time the icemaker on/off switch is turned to the **OFF (O)** position.

If the ambient temperature will drop below freezing, system to prevent serious property damage due have a qualified technician drain the water supply to flooding caused by ruptured water lines or connections.

### FOOD STORAGE GUIDE

Wrap or store food in the refrigerator in airtight and moisture-proof material unless otherwise noted. This prevents food odor and taste transfer throughout the refrigerator. For dated products, check date code to ensure freshness.

Items	How to
<b>Butter or margarine</b>	▶ Keep opened butter in a covered dish or closed compartment. When storing an extra supply, wrap in freezer packaging and freeze.
<b>Cheese</b>	▶ Store in the original wrapping until you are ready to use it. Once opened, rewrap tightly in plastic wrap or aluminum foil.
<b>Milk</b>	▶ Wipe milk cartons. For best storage, place milk on interior shelf, not on door shelf.
<b>Eggs</b>	▶ Store in original carton on interior shelf, not on door shelf.
<b>Fruit</b>	▶ Do not wash or hull the fruit until it is ready to be used. Sort and keep fruit in its original container, in a crisper, or store in a completely closed paper bag on a refrigerator shelf.
<b>Leafy vegetables</b>	▶ Remove store wrapping and trim or tear off bruised and discolored areas. Wash in cold water and drain. Place in plastic bag or plastic container and store in crisper.
<b>Vegetables with skins (carrots, peppers)</b>	▶ Place in plastic bags or plastic container and store in crisper.
<b>Fish</b>	▶ Store fresh fish and shellfish in the freezer section if they are not being consumed the same day of purchase. It is recommended to consume fresh fish and shellfish the same day purchased.
<b>Leftovers</b>	▶ Cover leftovers with plastic wrap or aluminum foil, or store in plastic containers with tight lids.

## STORING FROZEN FOOD

**NOTE:** Check a freezer guide or a reliable cookbook for further information about preparing food for freezing or food storage times.

### Freezing

Your freezer will not quick-freeze a large quantity of food. Do not put more unfrozen food into the freezer than will freeze within 24 hours (no more than 2 to 3 lbs. of food per cubic foot of freezer space). Leave enough space in the freezer for air to circulate around packages. Be careful to leave enough room at the front so the door can close tightly.

Storage times will vary according to the quality and type of food, the type of packaging or wrap used (how airtight and moisture-proof) and the storage temperature. Ice crystals inside a sealed package are normal. This simply means that moisture in the food and air inside the package have condensed, creating ice crystals.

**NOTE:** Allow hot foods to cool at room temperature for 30 minutes, then package and freeze. Cooling hot foods before freezing saves energy.

### Packaging

Successful freezing depends on correct packaging. When you close and seal the package, it must not allow air or moisture in or out. If it does, you could have food odor and taste transfer throughout the refrigerator and could also dry out frozen food.

### Packaging recommendations:

- Rigid plastic containers with tight-fitting lids
- Straight-sided canning/freezing jars
- Heavy-duty aluminum foil
- Plastic-coated paper
- Non-permeable plastic wraps
- Specified freezer-grade self-sealing plastic bags

Follow package or container instructions for proper freezing methods.

### Do not use

- Bread wrappers
- Non-polyethylene plastic containers
- Containers without tight lids
- Wax paper or wax-coated freezer wrap
- Thin, semi-permeable wrap

**CAUTION:** Do not keep beverage cans or plastic food containers in the freezer compartment. They may break or burst if they freeze.

## REFRIGERATOR SECTION

### WATER DISPENSER

To dispense cold water, push on the dispenser switch with a glass.

**NOTE:** The dispenser is equipped with a light that turns on when the dispenser pad is engaged.

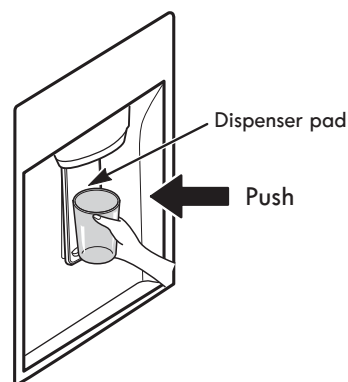

Some dripping may occur after dispensing. Hold your cup beneath the dispenser for a few seconds after dispensing to catch all of the drops.

**WARNING:** Do not put your fingers up the ice chute opening. Doing so can result in severe injury.

**CAUTION:** Do not dispense ice into fine china or crystal glasses. China or crystal can break.



## USING YOUR REFRIGERATOR

### REFRIGERATOR SHELVES

The shelves in your refrigerator are adjustable to meet your individual storage needs. Your model may have glass or wire shelves.

Adjusting the shelves to fit items of different heights will make finding the exact item you want easier. Doing so will also reduce the amount of time the refrigerator door is open which will save energy.

**IMPORTANT:** Do not clean glass shelves with warm water while they are cold. Shelves may break if exposed to sudden temperature changes or impact.

**⚠ CAUTION:** Glass shelves are heavy. Use special care when removing them.

#### Detaching the Shelf (Half Shelf Type)

1. Tilt up the front of the shelf and then lift the shelf straight up.
2. Pull the shelf out.

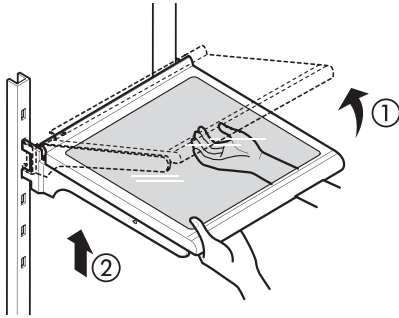

#### Assembling the Shelf (Half Shelf Type)

1. Tilt the front of the shelf up and guide the shelf hooks into the slots at a desired height.
2. Lower the front of the shelf so that the hooks drop into the slots.

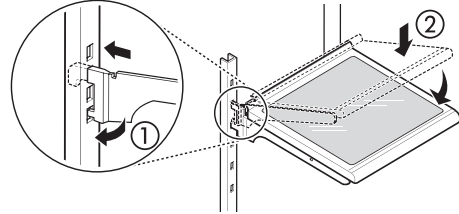

**⚠ CAUTION:** Make sure that shelves are level from one side to the other. Failure to do so may result in the shelf falling or spilling food.

#### Folding Shelf (on some models)

You can store taller items, such as a gallon container or bottles, by simply pushing the front half of the shelf underneath the back half of the shelf. Pull the front of the shelf toward you to return to a full shelf.

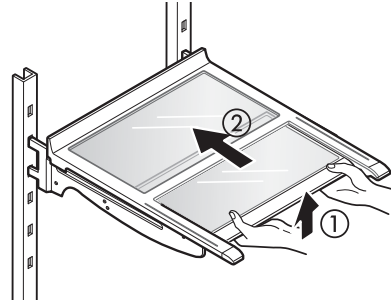

### HUMIDITY CONTROLLED CRISPER

The crispers provide fresher tasting fruit and vegetables by letting you easily control humidity inside the drawer.

You can control the amount of humidity in the moisture-sealed crispers by adjusting the control to any setting between **VEGETABLES** and **FRUIT**.

- **VEGETABLES** keeps moist air in the crisper for best storage of fresh, leafy vegetables.
- **FRUIT** lets moist air out of the crisper for best storage of fruit.

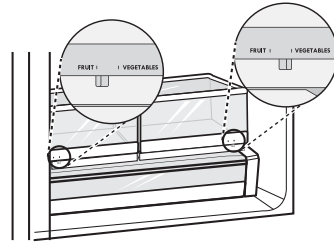

### REMOVING THE HUMIDITY CONTROLLED CRISPER

1. To remove, pull out the crisper (1) or (2) to full extension, lift the front up, and pull straight out.

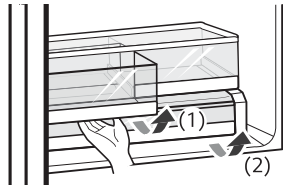

2. To install, slightly tilt up the front, insert the crisper or drawer into the frame and push it back into place.

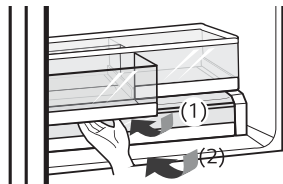

### Crisper Cover

To remove, lift the front of the cover up until it detaches from the back wall of the cabinet, then pull it out.

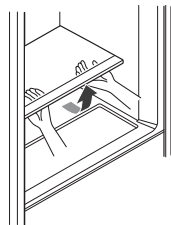

### PANTRY DRAWER

This drawer can be used for large party trays, deli items and beverages. (This drawer should not be used to store vegetables that require high humidity.)

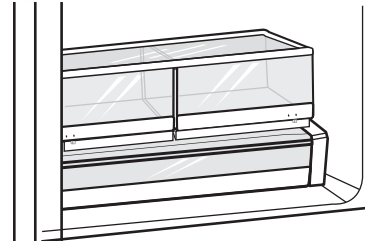

- **CAUTION:** Do not store glass bottles in the pantry. If they are frozen, they can break and cause personal injury.

### DOOR BIN

The door bins are removable for easy cleaning and adjustment.

1. To remove the bin, simply lift the bin up and pull straight out.
2. To replace the bin, slide it in above the desired support and push down until it snaps into place.

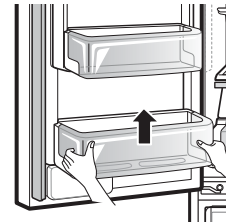

### CAUTION

- Regularly detach and wash the storage bins and shelves; they can become easily contaminated by food.
- Do not apply excessive force while detaching or assembling the storage bins.
- Do not use the dishwasher to clean the storage bins and shelves.

## USING YOUR REFRIGERATOR

### PREVIEW GRAB-N-GO (On some models)

The PreView Grab-N-Go compartment allows for easy access to commonly used food items.



### PREVIEW GRAB-N-GO COMPARTMENT (On some models)

To access the PreView Grab-N-Go compartment, lightly press the button on the right refrigerator door handle to open the door.



### PREVIEW FUNCTION (On some models)

The PreView function on the Grab-N-Go lets you see if you're running low on frequently used items like beverages and snacks, without opening the refrigerator door.

1. Knock twice on the glass to turn the LED light inside the Grab-N-Go on or off.
2. The LED light turns off automatically after ten seconds.

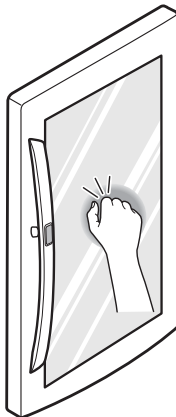

- The PreView function is disabled when the right refrigerator door is open, for two seconds after closing the door, and when the ice dispenser is in use.
- Knock near the center of the glass. Knocking near the edges of the glass may not activate the PreView function properly.
- Knock hard enough that the knocking sound is audible.
- The PreView function may activate if a loud noise occurs near the refrigerator.

### GRAB-N-GO CASE (On some models)

To open the Grab-N-Go case, slightly push the marked area to pop it open. The Grab-N-Go Case is removable for easy cleaning and adjustment.

1. To remove the Grab-N-Go case, lift up and pull out.
2. To replace the Grab-N-Go case, line the tabs on the Grab-N-Go case with the slots on the door and push down until the case snaps into place.

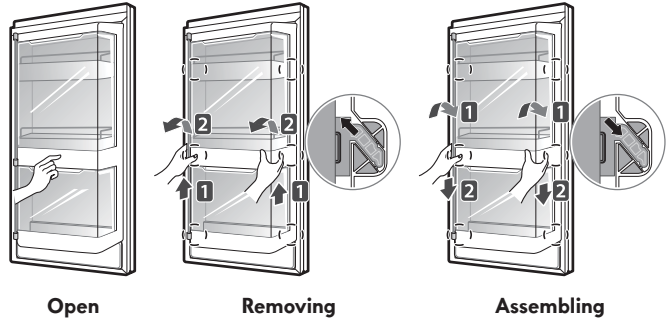

### GRAB-N-GO LOWER SHELF (On some models)

The Grab-N-Go lower shelf is removable for easy cleaning.

1. To remove the lower shelf, lift the shelf retainer up and out.
2. Remove the two screws from the shelf and pull it straight out.
3. Reverse procedure to replace.

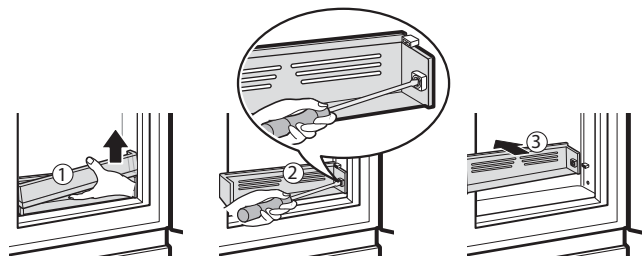

## Replacing the Air Filter



It is recommended that you replace the air filter:

- Approximately every six months.
- When the Replace Filter **CHANGE AIR FILTER** light turns on.

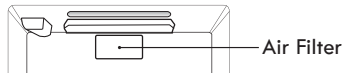

### 1. Remove the Old Filter

Turn the filter cover to the left to detach it from the refrigerator wall. The filter is located on the inside of the filter cover.

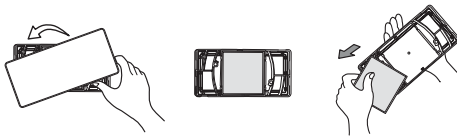

### 2. Install a New Air Filter.

Place the new filter inside of the cover with the side that says "Front" facing outward.

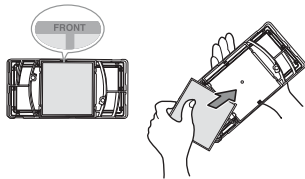

### 3. Turn the filter cover to the right to attach it to the refrigerator wall.

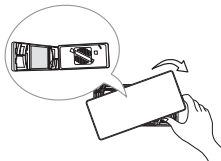

### 4. Press and hold the Air Filter button for three seconds to reset the filter sensor.



**NOTE:** To purchase a replacement air filter, visit your local Sears store, or call 1-844-553-6667. You may also purchase online at [www.kenmore.com](http://www.kenmore.com)

## FREEZER SECTION

### EXTRA ICE BIN

1. Pull the Freezer Drawer and the top Pullout Drawer out as far as possible to remove the Extra Ice Bin.
2. Gently lift and pull out the ice bin.
3. To replace, pull both drawers out as far as possible, and set the bin in its correct position in the Pullout Drawer. Close the Pullout Drawer and then the Freezer Drawer.

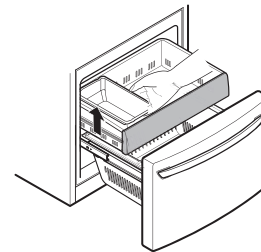
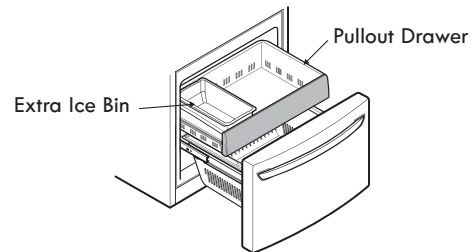

**CAUTION:** Pinch hazard! Keep hands and feet clear of the bottom of the freezer drawer when opening and closing.

## USING YOUR REFRIGERATOR

### DURABASE

1. To remove the Durabase, push it to the back as much as possible. Tilt up the front of the Durabase and pull straight out.
2. To replace, insert the Durabase in the rail assembly.

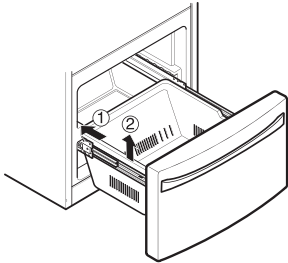

### Durabase®

The Durabase® divider allows you to organize the Durabase® area into sections. It can be adjusted from side to side to accommodate items of different sizes.

**⚠ WARNING:** If the Durabase divider is removed, there is enough open space for children or pets to crawl inside. To prevent accidental child and pet entrapment or suffocation risk, DO NOT allow children or pets to touch or go near the drawer.

### DURABASE DIVIDER

The Durabase divider allows you to organize the Durabase area into sections.

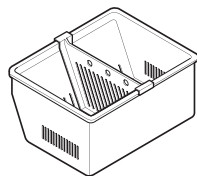

### PULLOUT DRAWERS

1. To remove, pull the drawer out to full extension. Lift the front of the drawer up, then pull it straight out.

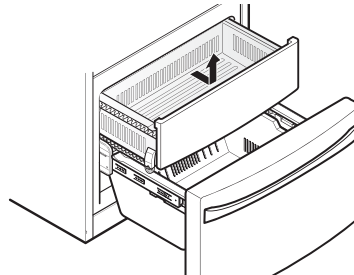

2. To install, slightly tilt up the front and insert the drawer into the frame and push it back into place.

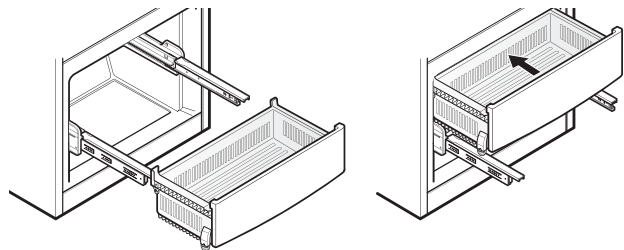



# WATER FILTER

## WATER FILTER



It is recommended that you replace the water filter:

- Approximately every six months.
- When the water filter indicator **CHANGE WATER FILTER** turns on.
- When the water dispenser output decreases.
- When the ice cubes are smaller than normal.

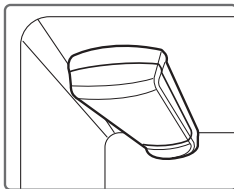

### Before Replacing the Water Filter.

If the top shelf, located below the water filter, is in the highest position, it will need to be removed prior to replacing the water filter.

To remove any shelf—Tilt up the front of the shelf ① and lift it ②. Pull the shelf out.

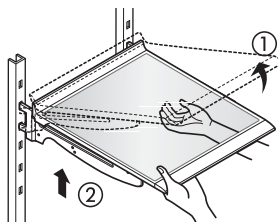

### 1. Remove the old water filter.

- Lower or remove the top left shelf to allow the water filter to rotate all the way down.
- Pinch the sides to open the water filter cover.

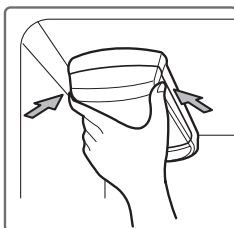

**NOTE:** Replacing the water filter causes a small amount of water (around 1 oz. or 25 cc) to drain. Place a cup under the front end of the water filter cover to collect any leaking water. Hold the water filter upright, once it is removed, to prevent any remaining water from spilling out of the water filter.

- Make sure to rotate the filter down completely before pulling it out of the manifold hole.
- Pull the water filter downward and turn it counterclockwise.

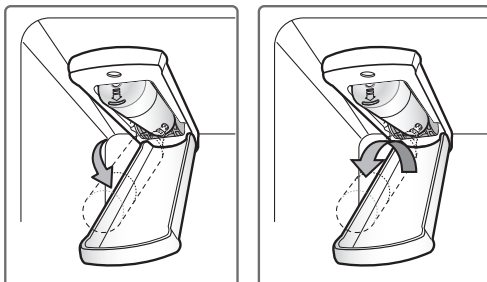

### 2. Replace with a new water filter.

- Take the new water filter out of its packing and remove the protective cover from the o-rings.

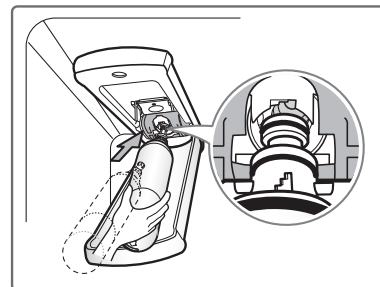

- With the water filter tabs in the horizontal position, push the new water filter into the manifold hole and turn it clockwise.

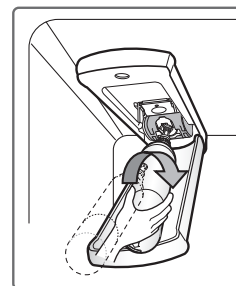

- Rotate the water filter up into position and close the cover. The cover will click when closed correctly.

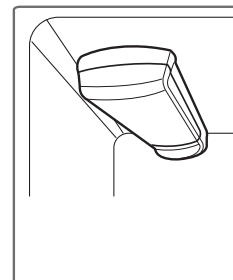
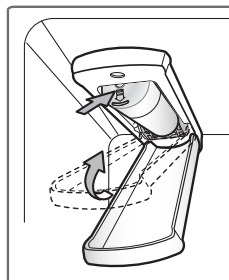

- 3. After the water filter is replaced, dispense 2.5 gallons of water (flush for approximately 5 minutes) to remove trapped air and contaminants from the system. Do not dispense the entire 2.5 gallon amount continuously. Depress and release the dispenser pad for cycles of 30 seconds ON and 60 seconds OFF.

**NOTE:** To purchase a replacement filter, visit your local Sears store, or call 1-844-553-6667, You may also purchase online at [www.kenmore.com](http://www.kenmore.com)

## WATER FILTER

### Performance Data Sheet

Use Replacement Cartridge: MDJ64844602(9980)

The concentration of the indicated substances in water entering the system was reduced to a concentration less than or equal to the permissible limit for water leaving the system as specified in NSF/ANSI Standard 42 and Standard 53 and Standard 401.



System tested and certified by NSF International against NSF/ANSI Standard 42, Standard 53 and Standard 401. For the reduction of substances listed below.

Contaminant Reduction	Average Influent Challenge	NSF specified Challenge Concentration	Avg % Reduction	Average Product Water Concentration	Max Permissible Product Water Concentration	NSF Reduction Requirement
Chlorine Taste and Odor	2.0 µg/L	2.0 µg/L ± 10%	>97.5%	0.050 µg/L	N/A	≥ 50.00%
Nominal Particulate Class I, ≥ 0.5 to < 1.0 µm	12,000,000 pts/mL	At least 10,000 particles/mL	99.80%	24,000 pts/ml	N/A	≥ 85.00%
Asbestos	180 MFL	10 <sup>7</sup> to 10 <sup>8</sup> MFL; fibers greater than 10 µg/Lin length	>99.00%	< 1 MFL	N/A	≥ 99.00%
Atrazine	8.5 µg/L	9.0 µg/L ± 10%	>94.10%	0.500 µg/L	3.0 µg/L	NA
Benzene	15.0 µg/L	15.0 µg/L ± 10%	>96.60%	0.510 µg/L	5.0 µg/L	NA
Carbofuran	74.0 µg/L	80.0 µg/L ± 10%	98.30%	1.258 µg/L	40 µg/L	NA
Lindane	1.9 µg/L	2.0 µg/L ± 10%	>99.00%	0.019 µg/L	0.2 µg/L	NA
P-Dichlorobenzene	230.0 µg/L	225.0 µg/L ± 10%	>99.80%	0.460 µg/L	75.0 µg/L	NA
2,4-D	210.0 µg/L	210.0 µg/L ± 10%	>99.90%	0.210 µg/L	70.0 µg/L	NA
Lead @ pH 6.5	140.0 µg/L	150.0 µg/L ± 10%	99.60%	0.560 µg/L	10.0 µg/L	NA
Lead @ pH 8.5	150.0 µg/L	150.0 µg/L ± 10%	>90%	<0.500 µg/L	10.0 µg/L	NA
Mercury @ pH 6.5	5.9 µg/L	6.0 µg/L ± 10%	91.00%	0.531 µg/L	2.0 µg/L	NA
Mercury @ pH 8.5	5.6 µg/L	6.0 µg/L ± 10%	92.50%	<0.420 µg/L	2.0 µg/L	NA
Cyst*	100,000 cysts/L	Minimum 50,000 cysts/L	>99.99%	10	N/A	≥ 99.95%
Atenolol	240 ng/L	200 ± 40% ng/L	> 95.50%	10.80 ng/L	30 ng/L	NA
Carbamazepine	1600 ng/L	1400 ± 40% ng/L	98.40%	25.60 ng/L	200 ng/L	NA
DEET	1600 ng/L	1400 ± 40% ng/L	97.10%	46.40 ng/L	200 ng/L	NA
Trimethoprim	170 ng/L	140 ± 40% ng/L	>96.80%	5.44 ng/L	20 ng/L	NA
Linuron	160 ng/L	140 ± 40% ng/L	>96.60%	5.44 ng/L	20 ng/L	NA
Phenytoin	200 ng/L	200 ± 40% ng/L	>94.80%	10.40 ng/L	30 ng/L	NA
Ibuprofen	400 ng/L	400 ± 40% ng/L	>94.50%	22.00 ng/L	60 ng/L	NA
Naproxen	140 ng/L	140 ± 40% ng/L	>96.10%	5.46 ng/L	20 ng/L	NA
Estrone	120 ng/L	140 ± 40% ng/L	>96.10%	4.68 ng/L	20 ng/L	NA
Bisphenol A	2000 ng/L	2000 ± 40% ng/L	>98.90%	22.00 ng/L	300 ng/L	NA
Nonyl Phenol	1600 ng/L	1400 ± 40% ng/L	>97.10%	46.40 ng/L	200 ng/L	NA

\* Based on the use of Cryptosporidium parvum oocysts.

Application Guidelines/Water Supply Parameters	
Service Flow	0.5 gpm (1.9 lpm)
Water Supply	Potable Water
Water Pressure	20-120 psi (138 - 827 kPa)
Water Temperature	33°F - 100°F (0.6°C - 38°C)

It is essential that the manufacturer's recommended installation, maintenance and water filter replacement requirements be carried out for the product to perform as advertised.

**NOTE:** While the testing was performed under standard laboratory conditions, actual performance may vary.

**NOTE:** To purchase a replacement filter, visit your local Sears store, or call 1-844-553-6667. You may also purchase online at [www.kenmore.com](http://www.kenmore.com)

Product distributed in the United States by Transform SR Brands Management LLC, Hoffman Estates, IL 60179 U.S.A.

NSF is a trademark of NSF International.

## WARNING

**To reduce the risk associated with ingestion of contaminants: Do not use with water that is microbiologically unsafe or of unknown quality without adequate disinfection before and after the system.** Systems certified for cyst reduction may be used on disinfected water that may contain filterable cysts. EPA Establishment Number 10350-MN-005

## CAUTION

**To reduce the risk associated with property damage due to water leakage:**

- **Read and follow** the Water Filter instructions before installation and use of this system.
- Installation and use **MUST** comply with all state and local plumbing codes.
- **Do not** install if water pressure exceeds 120 psi (827 kPa). Contact a plumbing professional if you are uncertain of how to check your water pressure.
- **Do not** install where water hammer conditions may occur. If water hammer conditions exist, you must install a water hammer arrester. Contact a plumbing professional if you are uncertain of how to check for this condition.
- **Do not** install on hot water supply lines. The maximum operating water temperature of this water filter system is 100°F (38°C).
- **Protect water filter from freezing.** Do not operate refrigerator in ambient conditions below 55°F (12.7°C). Drain water filter when storing unit in temperatures below 40°F (4.4°C).
- The disposable water filter must be replaced every six months, at the rated capacity, or if a noticeable reduction in flow rate occurs.

## CARE AND CLEANING

### **WARNING**



#### **Explosion Hazard**

Use non-flammable cleaner. Failure to do so can result in fire, explosion, or death.

Both the refrigerator and freezer sections defrost automatically; however, clean both sections about once a month to prevent odors. Wipe up spills immediately.

### **GENERAL CLEANING TIPS**

- Unplug refrigerator or disconnect power.
- Remove all removable parts, such as shelves, crispers, etc. Refer to sections in **Using Your Refrigerator** for removal instructions.
- Use a clean sponge or soft cloth and a mild detergent in warm water. Do not use abrasive or harsh cleaners.
- Hand wash, rinse and dry all surfaces thoroughly.
- Plug in refrigerator or reconnect power.

### **EXTERIOR**

Waxing external painted metal surfaces helps provide rust protection. Do not wax plastic parts. Wax painted metal surfaces at least twice a year using appliance wax (or auto paste wax). Apply wax with a clean, soft cloth.

For products with a stainless steel exterior, use a clean sponge or soft cloth and a mild detergent in warm water. Do not use abrasive or harsh cleaners. Dry thoroughly with a soft cloth.

### **INSIDE WALLS (allow freezer to warm up so the cloth will not stick)**

To help remove odors, you can wash the inside of the refrigerator with a mixture of baking soda and warm water. Mix 2 tablespoons of baking soda to 1 quart of water (26 g soda to 1 liter water.) Be sure the baking soda is completely dissolved so it does not scratch the surfaces of the refrigerator.

 **CAUTION:** While cleaning the inside, do not spray water.

### **DOOR LINERS AND GASKETS**

Use a clean sponge or soft cloth and a mild detergent in warm water. Do not use cleaning waxes, concentrated detergents, bleaches, or cleaners containing petroleum on plastic refrigerator parts.

### **PLASTIC PARTS (Covers and Panels)**

Use a clean sponge or soft cloth and a mild detergent in warm water. Do not use window sprays, abrasive cleansers, or flammable fluids. These can scratch or damage the material.

### **CONDENSER COILS**

Use a vacuum cleaner with an attachment to clean the condenser cover and vents. Do not remove the panel covering the condenser coil area.

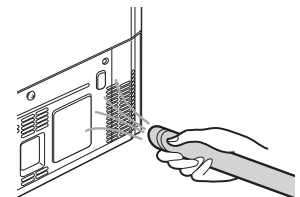

## LIGHT BULB REPLACEMENT

### WARNING

#### Electrical Shock Hazard

Before replacing a Compartment Lamp, either unplug the refrigerator or turn off power at the circuit breaker or fuse box.

**NOTE:** The refrigerator and freezer compartments use LED interior lighting, and service should be performed by a qualified technician.

## POWER INTERRUPTIONS

1. If the power will be out for 24 hours or less, keep all refrigerator doors closed to help foods stay cold and frozen.
2. If the power will be out for more than 24 hours, remove all frozen food and store it in a frozen food locker.

## WHEN YOU GO ON VACATION

If you choose to leave the refrigerator on while you are away, follow these steps to prepare your refrigerator before you leave.

1. Use up any perishables and freeze other items.
2. Turn off the icemaker and empty the ice bin.

If you choose to turn the refrigerator off before you leave, follow these steps.

1. Remove all food from the refrigerator.
2. Depending on your model, set the thermostat control (refrigerator control) to OFF. See the Setting the Controls section.
3. Clean the refrigerator, wipe it and dry well.
4. Tape rubber or wood blocks to the tops of both doors to prop them open far enough for air to get in. This stops odor and mold from building up.

## WHEN YOU MOVE

When you are moving your refrigerator to a new home, follow these steps to prepare it for the move.

1. Remove all food from the refrigerator and pack all frozen food in dry ice.
2. Unplug the refrigerator.
3. Clean, wipe and dry thoroughly.
4. Take out all removable parts, wrap them well and tape them together so they do not shift and rattle during the move. Refer to the **Using your Refrigerator** section for removal instructions.
5. Depending on the model, raise the front of the refrigerator so it rolls more easily OR screw in the leveling legs all the way so they do not scrape the floor. See the **Leveling and Door Alignment** section.
6. Tape the doors shut and tape the power cord to the refrigerator cabinet.

When you get to your new home, put everything back and refer to the **Refrigerator Installation** section for preparation instructions.

## CONNECTING THE WATER LINE

### BEFORE YOU BEGIN

This water line installation is not covered by the refrigerator warranty. Follow these instructions carefully to minimize the risk of expensive water damage.

Water hammer (water banging in the pipes) in house plumbing can cause damage to refrigerator parts and can lead to water leakage or flooding. Call a qualified plumber to correct water hammer before installing the water supply line to the refrigerator.

**⚠ CAUTION:** To prevent burns and product damage, only connect the refrigerator water line to a cold water supply.

If you use your refrigerator before connecting the water line, make sure the icemaker is turned OFF at the control panel.

**⚠ CAUTION:** Do not install the icemaker tubing in areas where temperatures fall below freezing.

### WATER PRESSURE

**A cold water supply.** The water pressure must be between 20 and 120 psi. If the refrigerator is installed in an area with low water pressure (below 20 psi), you can install a booster pump to compensate for the low pressure.

If a **reverse osmosis water filtration system** is connected to your cold water supply, this water line installation is not covered by the refrigerator warranty. Follow the following instructions carefully to minimize the risk of expensive water damage.

If a **reverse osmosis water filtration system** is connected to your cold water supply, the water pressure to the reverse osmosis system needs to be a minimum of 40 to 60 psi (276-414 kPa or 2.8-4.2 kgf/cm<sup>2</sup>, less than 2.0-3.0 sec. to fill a cup of 7 oz or 198 cc capacity).

If the water pressure from the reverse osmosis system is less than 20 psi or 138 kPa or 1.4 kgf/cm<sup>2</sup> (takes more than 4.0 sec to fill a cup of 7 oz or 198 cc capacity):

- Check to see if the sediment filter in the reverse osmosis system is blocked. Replace the filter if necessary.
- Allow the storage tank on the reverse osmosis system to refill after heavy usage.
- If the issue concerning water pressure from reverse osmosis remains, call a licensed, qualified plumber.
- All installations must be in accordance with local plumbing code requirements.

**⚠ CAUTION:** Wear eye protection during installation to prevent injury.

### WHAT YOU WILL NEED

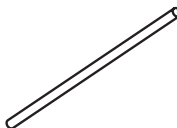
- **Copper Tubing**, 1/4 in. outer diameter, to connect the refrigerator to the water supply. Be sure both ends of the tubing are cut square. 
- To determine how much tubing you need: measure the distance from the water valve on the back of the refrigerator to the water supply pipe. Then, add 8 feet (2.4 m). Be sure there is sufficient extra tubing (about 8 feet [2.4 m] coiled into 3 turns of about 10 in. [25 cm] diameter) to allow the refrigerator to move out from the wall after installation.

- **Power drill.**
- **1/2 in. or adjustable wrench.**
- **Flat blade and Phillips head screwdrivers.**

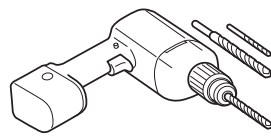
- **Two 1/4 in. outer diameter compression nuts and 2 ferrules (sleeves)** to connect the copper tubing to the shutoff valve and the refrigerator water valve. 

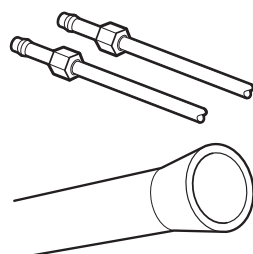
- If your existing copper water line has a flared fitting at the end, you will need an **adapter** (available at plumbing supply stores) to connect the water line to the refrigerator OR you can cut off the flared fitting with a tube cutter and then use a compression fitting. 

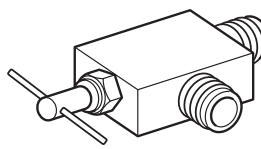
- **Shutoff valve to connect to the cold water line.** The shutoff valve should have a water inlet with a minimum inside diameter of 5/32 in. at the point of connection to the COLD WATER LINE. Saddle-type shutoff valves are included in many water supply kits. Before purchasing, make sure a saddle-type valve complies with your local plumbing codes. 

**NOTE:** A Self Piercing Saddle Type Water Valve should not be used.

## ⚠ WARNING

### Electrical Shock Hazard

When using any electrical device (such as a power drill) during installation, be sure the device is battery powered, double insulated or grounded in a manner that will prevent the hazard of electric shock.

**INSTALLATION INSTRUCTIONS**

Install the shutoff valve on the nearest frequently used drinking water line.

**1. SHUT OFF THE MAIN WATER SUPPLY**

Turn on the nearest faucet to relieve the pressure on the line.

**2. CHOOSE THE VALVE LOCATION**

Choose a location for the valve that is easily accessible. It is best to connect into the side of a vertical water pipe. When it is necessary to connect into a horizontal water pipe, make the connection to the top or side, rather than at the bottom, to avoid drawing off any sediment from the water pipe.

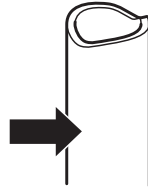

**3. DRILL THE HOLE FOR THE VALVE**

Drill a 1/4 in. hole in the water pipe using a sharp bit. Remove any burrs resulting from drilling the hole in the pipe. Be careful not to allow water to drain into the drill. Failure to drill a 1/4 in. hole may result in reduced ice production or smaller cubes.

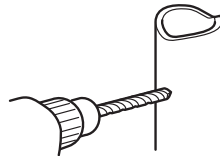

**NOTE:** The hookup line cannot be white, plastic tubing. Licensed plumbers must use only copper tubing (NDA tubing #49595 or #49599) or Cross Link Polyethylene (PEX) tubing.

**4. FASTEN THE SHUTOFF VALVE**

Fasten the shutoff valve to the cold water pipe with the pipe clamp.

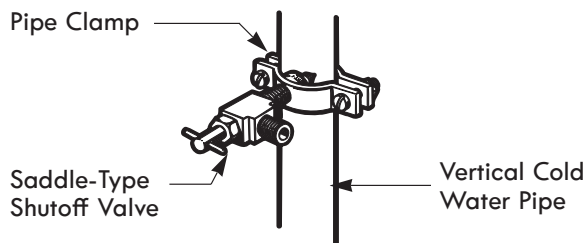

**NOTE:** Commonwealth of Massachusetts Plumbing Codes 248CMR shall be adhered to. Saddle valves are illegal and use is not permitted in Massachusetts. Consult with your licensed plumber.

**5. TIGHTEN THE PIPE CLAMP**

Tighten the clamp screws until the sealing washer begins to swell.

**NOTE:** Do not overtighten clamp or you may crush the tubing.

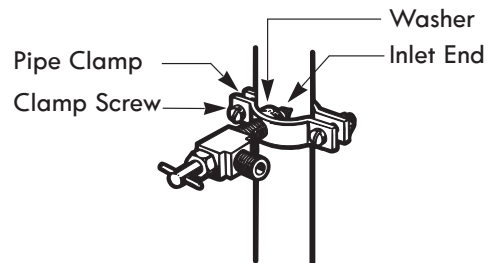

**6. ROUTE THE TUBING**

Route the tubing between the cold water line and the refrigerator.

Route the tubing through a hole drilled in the wall or floor (behind the refrigerator or adjacent base cabinet) as close to the wall as possible.

**NOTE:** Be sure there is sufficient extra tubing (about 8 feet coiled into 3 turns of about 10 in. diameter) to allow the refrigerator to move out from the wall after installation.

**7. CONNECT THE TUBING TO THE VALVE**

Place the compression nut and ferrule (sleeve) for copper tubing onto the end of the tubing and connect it to the shutoff valve. Make sure the tubing is fully inserted into the valve. Tighten the compression nut securely.

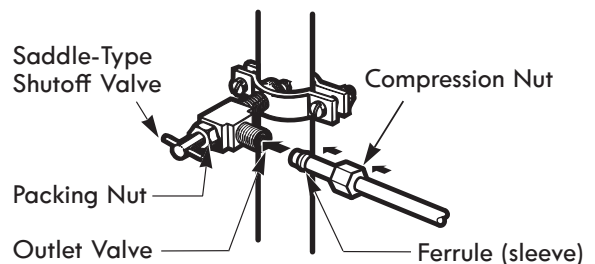

**NOTE:** Commonwealth of Massachusetts Plumbing Codes 248CMR shall be adhered to. Saddle valves are illegal and their use is not permitted in Massachusetts. Consult with your licensed plumber.

## CONNECTING THE WATER LINE

### 8. FLUSH OUT THE TUBING

Turn the main water supply on and flush out the tubing until the water is clear.

Shut the water off at the water valve after about one quart of water has been flushed through the tubing.

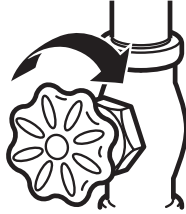

### 9. CONNECT THE TUBING TO THE REFRIGERATOR

#### **⚠ WARNING**

Before making the connection to the refrigerator, be sure that the refrigerator power cord is not plugged into the wall outlet.

1. Remove the plastic flexible cap from the water valve.
2. Place the compression nut and ferrule (sleeve) onto the end of the tubing as shown.
3. Insert the end of the copper tubing into the connection as far as possible. While holding the tubing, tighten the fitting.

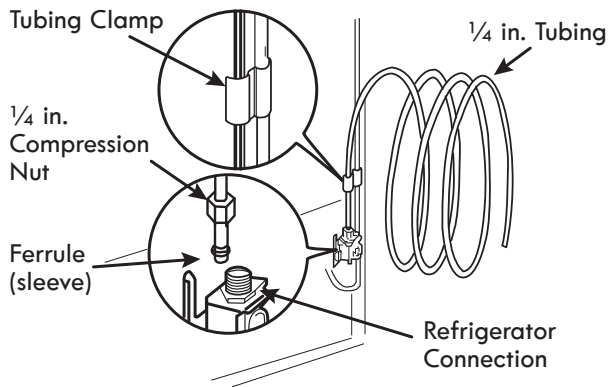

### 10. TURN THE WATER ON AT THE SHUTOFF VALVE

Tighten any connections that leak.

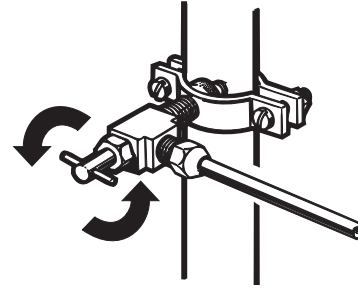

**⚠ CAUTION:** Check to see if leaks occur at the water line connections.

### 11. PLUG IN THE REFRIGERATOR

Arrange the coil of tubing so that it does not vibrate against the back of the refrigerator or against the wall.

Push the refrigerator back to the wall.

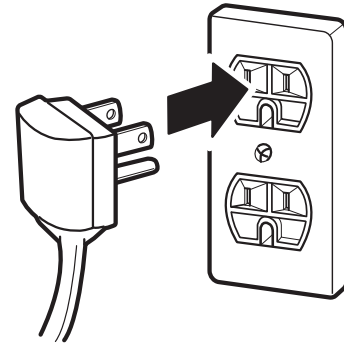

### 12. START THE ICEMAKER

Turn the icemaker ON at the control panel.

The icemaker will not begin to operate until it reaches its operating temperature of 15°F (-9°C) or below. It will then begin operation automatically if the icemaker button has been turned ON.



## TROUBLESHOOTING GUIDE

Before conducting troubleshooting, make sure that the following basic requirements are met:

Service Flow	0.5 gpm (1.9 lpm)
Water Supply	Potable Water
Water Pressure	20-120 psi (138 - 827 kPa)
Operating Ambient Temperature Limits	55°F - 110°F
Electrical Ratings	115 Volts, 60 Hz, AC only, and fused at 15 or 20 amperes.

### COOLING

Problem	Possible Causes	Solutions
Refrigerator and Freezer section are not cooling.	The refrigerator control is set to OFF (some models).	Turn the control ON. Refer to the <b>Setting the Controls</b> section for proper temperature settings.
	Refrigerator is set to demo mode.	Demo Mode allows the lights and control display to work normally while disabling cooling to save energy while on the showroom floor. Refer to the <b>Setting the Controls</b> section for instructions on how to disable Demo Mode.
	Refrigerator is in the defrost cycle.	During the defrost cycle, the temperature of each compartment may raise slightly. Wait 30 minutes and confirm the proper temperature has been restored once the defrost cycle has completed.
	Refrigerator was recently installed.	It may take up to 24 hours for each compartment to reach the desired temperature.
	Refrigerator was recently relocated.	If the refrigerator was stored for a long period of time or moved on its side, it is necessary for the refrigerator to stand upright for 24 hours before connecting it to power.
Cooling system runs too much.	Refrigerator is replacing an older model.	Modern refrigerators require more operating time but use less energy due to more efficient technology.
	Refrigerator was recently plugged in or power restored.	The refrigerator will take up to 24 hours to cool completely.
	Door opened often or a large amount of food / hot food was added.	Adding food and opening the door warms the refrigerator, requiring the compressor to run longer in order to cool the refrigerator back down. In order to conserve energy, try to get everything you need out of the refrigerator at once, keep food organized so it is easy to find, and close the door as soon as the food is removed. (Refer to the <b>Food Storage Guide</b> .)
	Doors are not closed completely.	Firmly push the doors shut. If they will not shut all the way, see the <b>Doors will not close completely or pop open</b> section in Parts & Features Troubleshooting.
	Refrigerator is installed in a hot location.	The compressor will run longer under warm conditions. At normal room temperatures (70°F) expect your compressor to run about 40% to 80% of the time. Under warmer conditions, expect it to run even more often. The refrigerator should not be operated above 110°F.
	Condenser / back cover is clogged.	Use a vacuum cleaner with an attachment to clean the condenser cover and vents. Do not remove the panel covering the condenser coil area.

## TROUBLESHOOTING GUIDE

### COOLING

Problem	Possible Causes	Solutions
Refrigerator or Freezer section is too warm.	Refrigerator was recently installed.	It may take up to 24 hours for each compartment to reach the desired temperature.
	Air vents are blocked.	Rearrange items to allow air to flow throughout the compartment. Refer to the Airflow diagram in the <b>Using Your Refrigerator</b> section.
	Doors are opened often or for long periods of time.	When the doors are opened often or for long periods of time, warm, humid air enters the compartment. This raises the temperature and moisture level within the compartment. To lessen the effect, reduce the frequency and duration of door openings.
	Unit is installed in a hot location.	The refrigerator should not be operated in temperatures above 110F.
	A large amount of food or hot food was added to either compartment.	Adding food warms the compartment requiring the cooling system to run. Allowing hot food to cool to room temperature before putting it in the refrigerator will reduce this effect.
	Doors not closed correctly.	See the <b>Doors will not close correctly or pop open</b> section in Parts & Features Troubleshooting.
	Temperature control is not set correctly.	If the temperature is too warm, adjust the control one increment at a time and wait for the temperature to stabilize. Refer to the <b>Setting the Controls</b> section for more information.
Interior moisture buildup.	Defrost cycle has recently completed.	During the defrost cycle, the temperature of each compartment may raise slightly and condensation may form on the back wall. Wait 30 minutes and confirm the proper temperature has been restored once the defrost cycle has completed.
	Doors are opened often or for long periods of time.	When the doors are opened often or for long periods of time, warm, humid air enters the compartment. This raises the temperature and moisture level within the compartment. To lessen the effect, reduce the frequency and duration of door openings.
	Doors not closed correctly.	See the <b>Doors will not close correctly</b> section in the <b>Troubleshooting</b> section.
	Weather is humid.	Humid weather allows additional moisture to enter the compartments when the doors are opened leading to condensation or frost. Maintaining a reasonable level of humidity in the home will help to control the amount of moisture that can enter the compartments.
	Defrost cycle recently completed.	During the defrost cycle, the temperature of each compartment may raise slightly and condensation may form on the back wall. Wait 30 minutes and confirm that the proper temperature has been restored once the defrost cycle has completed.
Food is not packaged correctly.	Food stored uncovered or unwrapped, and damp containers can lead to moisture accumulation within each compartment. Wipe all containers dry and store food in sealed packaging to prevent condensation and frost.	

## COOLING/ICE &amp; WATER

Problem	Possible Causes	Solutions
Food is freezing in the refrigerator compartment.	Food with high water content was placed near an air vent.	Rearrange items with high water content away from air vents.
	Refrigerator temperature control is set incorrectly.	If the temperature is too cold, adjust the control one increment at a time and wait for the temperature to stabilize. Refer to the <b>Setting the Controls</b> section for more information.
	Refrigerator is installed in a cold location.	When the refrigerator is operated in temperature below 41°F (5°C), food can freeze in the refrigerator compartment. The refrigerator should not be operated in temperature below 55°F (13°C).
Frost or ice crystals form on frozen food (outside of package).	Door is opened frequently or for long periods of time.	When the doors are opened often or for long periods of time, warm, humid air enters the compartment. This raises the temperature and moisture level within the compartment. Increased moisture will lead to frost and condensation. To lessen the effect, reduce the frequency and duration of door openings.
	Door is not closing properly.	Refer to the <b>Doors will not close correctly or pop open</b> section in the Troubleshooting section.
Refrigerator or Freezer section is too cold.	Incorrect temperature control settings.	If the temperature is too cold, adjust the control one increment at a time and wait for the temperature to stabilize. Refer to the <b>Setting the Controls</b> section for more information.
Frost or ice crystals on frozen food (inside of sealed package).	Condensation from food with a high water content has frozen inside of the food package.	This is normal for food items with a high water content.
	Food has been left in the freezer for a long period of time.	Do not store food items with high water content in the freezer for a long period of time.
Icemaker is not making enough ice.	Demand exceeds ice storage capacity.	The icemaker will produce approximately 70-182 cubes in a 24 hour period.
	House water supply is not connected, valve is not turned on fully, or valve is clogged.	Connect the refrigerator to a cold water supply with adequate pressure and turn the water shutoff valve fully open. If the problem persists, it may be necessary to contact a plumber.
	Water filter has been exhausted.	It is recommended that you replace the water filter: <ul style="list-style-type: none"> <li>• Approximately every six months.</li> <li>• When the water filter indicator turns on.</li> <li>• When the water dispenser output decreases.</li> <li>• When the ice cubes are smaller than normal.</li> </ul>
	Low house water supply pressure.	The water pressure must be between 20 and 120 psi on models without a water filter and between 40 and 120 psi on models with a water filter. If the problem persists, it may be necessary to contact a plumber or install a booster pump to compensate for the low pressure.
	Reverse Osmosis filtration system is used.	Reverse osmosis filtration systems can reduce the water pressure below the minimum amount and result in icemaker issues. (Refer to <b>Water Pressure</b> section.)
	Tubing connecting refrigerator to house supply valve is kinked.	The tubing can kink when the refrigerator is moved during installation or cleaning resulting in reduced water flow. Straighten or repair the water supply line and arrange it to prevent future kinks.

## TROUBLESHOOTING GUIDE

### ICE & WATER

Problem	Possible Causes	Solutions
Icemaker is not making enough ice (continued).	Doors are opened often or for long periods of time.	If the doors of the unit are opened often, ambient air will warm the refrigerator which will prevent the unit from maintaining the set temperature. Lowering the refrigerator temperature can help, as well as not opening the doors as frequently.
	Doors are not closed completely.	If the doors are not properly closed, ice production will be affected. See the <b>Doors will not close completely or pop open</b> section in Parts & Features Troubleshooting for more information.
	The temperature setting for the freezer is too warm.	The recommended temperature for the freezer compartment for normal ice production is 0°F. If the freezer temperature is warmer, ice production will be affected.
Dispensing water slowly.	Water filter has been exhausted.	It is recommended that you replace the water filter: <ul style="list-style-type: none"> <li>• Approximately every six months.</li> <li>• When the water filter indicator turns on.</li> <li>• When the water dispenser output decreases.</li> <li>• When the ice cubes are smaller than normal.</li> </ul>
	Reverse osmosis filtration system is used.	Reverse osmosis filtration systems can reduce the water pressure below the minimum amount and result in icemaker issues.  If the problem persists, it may be necessary to contact a plumber or install a booster pump to compensate for the low pressure.
	Low house water supply pressure.	The water pressure must be between 20 and 120 psi on models without a water filter and between 40 and 120 psi on models with a water filter.  If the problem persists, it may be necessary to contact a plumber or install a booster pump to compensate for the low pressure.
Not dispensing ice.	Doors are not closed completely.	Ice will not dispense if any of the refrigerator doors are left open.
	Infrequent use of the dispenser.	Infrequent use of the ice dispenser will cause the cubes to stick together over time, which will prevent them from properly dispensing. Check the ice bin for ice cubes clumping/sticking together. If they are, break up the ice cubes to allow for proper operation.
	The delivery chute is clogged with frost or ice fragments.	Eliminate the frost or ice fragments by removing the ice bin and clearing the chute with a plastic utensil. Dispensing cubed ice can also help prevent frost or ice fragment buildup.
	The dispenser display is locked.	Press and hold the <b>Lock</b> button for three seconds to unlock the control panel and dispenser.
	Ice bin is empty.	It may take up to 24 hours for each compartment to reach the desired temperature and for the icemaker to begin making ice. Make sure that the shutoff (arm/sensor) is not obstructed.  Once the ice supply in the bin has been completely exhausted, it may take up to 90 minutes before additional ice is available, and approximately 24 hours to completely refill the bin.

## ICE &amp; WATER

Problem	Possible Causes	Solutions
Icemaker is not making ice.	Refrigerator was recently installed or icemaker recently connected.	It may take up to 24 hours for each compartment to reach the desired temperature and for the icemaker to begin making ice.
	Icemaker not turned on.	Locate the icemaker on/off button and confirm that it is turned ON.
	The refrigerator is not connected to a water supply or the supply shutoff valve is not turned on.	Connect refrigerator to the water supply and turn the water shutoff valve fully open.
	Icemaker shutoff (feeler arm) obstructed.	If your icemaker is equipped with an ice shutoff arm, make sure that the arm moves freely.
	Reverse osmosis water filtration system is connected to your cold water supply.	Reverse osmosis filtration systems can reduce the water pressure below the minimum amount and result in icemaker issues. (Refer to the <b>Water Pressure</b> section.)
Not dispensing water.	New installation or water line recently connected.	Dispense 2.5 gallons of water (flush for approximately 5 minutes) to remove trapped air and contaminants from the system. Do not dispense the entire 2.5 gallon amount continuously. Depress and release the dispenser pad for cycles of 30 seconds ON and 60 seconds OFF.
	The dispenser panel is locked.	Press and hold the <b>Lock</b> button for three seconds to unlock the control panel and dispenser.
	The dispenser is not set for water dispensing.	The dispenser can be set for ice or water. Make certain that the control panel is set for the proper operation. Press the <b>Water</b> button on the control panel to dispense water.
	Refrigerator or freezer doors are not closed properly.	Water will not dispense if any of the refrigerator doors are left open.
	Water filter has been recently removed or replaced.	After the water filter is replaced, dispense 2.5 gallons of water (flush for approximately 5 minutes) to remove trapped air and contaminants from the system. Do not dispense the entire 2.5 gallon amount continuously. Depress and release the dispenser pad for cycles of 30 seconds ON and 60 seconds OFF.
	Tubing connecting refrigerator to house supply valve is kinked.	The tubing can kink when the refrigerator is moved during installation or cleaning resulting in reduced water flow. Straighten or repair the water supply line and arrange it to prevent future kinks.
	The house water supply is not connected, the valve is not turned on fully, or the valve is clogged.	Connect refrigerator to the water supply and turn the water shutoff valve fully open. If the problem persists, it may be necessary to contact a plumber.

## TROUBLESHOOTING GUIDE

### ICE & WATER

Problem	Possible Causes	Solutions
Ice has bad taste or odor.	Water supply contains minerals such as sulfur.	A water filter may need to be installed to eliminate taste and odor problems. <b>NOTE:</b> In some cases, a filter may not help. It may not be possible to remove all minerals / odor / taste in all water supplies.
	Icemaker was recently installed.	Discard the first few batches of ice to avoid discolored or bad tasting ice.
	Ice has been stored for too long.	Ice that has been stored for too long will shrink, become cloudy, and may develop a stale taste. Throw away old ice and make a new supply.
	The food has not been stored properly in either compartment.	Rewrap the food. Odors may migrate to the ice if food is not wrapped properly.
	The interior of the refrigerator needs to be cleaned.	See the <b>Care and Cleaning</b> section for more information.
	The ice storage bin needs to be cleaned.	Empty and wash the bin (discard old cubes). Make sure that the bin is completely dry before reinstalling it.
Dispensing warm water.	Refrigerator was recently installed.	Allow 24 hours after installation for the water storage tank to cool completely.
	The water dispenser has been used recently and the storage tank was exhausted.	Depending on your specific model, the water storage capacity will range from approximately 20 to 30 oz.
	Dispenser has not been used for several hours.	If the dispenser has not been used for several hours, the first glass dispensed may be warm. Discard the first 10 oz.
	Refrigerator is connected to the hot water supply.	Make sure that the refrigerator is connected to a cold water pipe. <b>⚠ WARNING:</b> Connecting the refrigerator to a hot water line may damage the icemaker.
Water has bad taste or odor.	Water supply contains minerals such as sulfur.	A water filter may need to be installed to eliminate taste and odor problems.
	Water filter has been exhausted.	It is recommended that you replace the water filter: <ul style="list-style-type: none"> <li>• Approximately every 6 months.</li> <li>• When the water filter indicator turns on.</li> <li>• When the water dispenser output decreases.</li> <li>• When the ice cubes are smaller than normal.</li> </ul>
	Refrigerator was recently installed.	Dispense 2.5 gallons of water (flush for approximately 5 minutes) to remove trapped air and contaminants from the system. Do not dispense the entire 2.5 gallon amount continuously. Depress and release the dispenser pad for cycles of 30 seconds ON and 60 seconds OFF.
Icemaker is making too much ice.	Icemaker shutoff (feeler arm) is obstructed.	Empty the ice bin. If your icemaker is equipped with an ice shutoff arm, make sure that the arm moves freely. Reinstall the ice bin and wait 24 hours to confirm proper operation.

## NOISE

Problem	Possible Causes	Solutions
Clicking	The defrost control will click when the automatic defrost cycle begins and ends. The thermostat control (or refrigerator control on some models) will also click when cycling on and off.	Normal Operation
Rattling	Rattling noises may come from the flow of refrigerant, the water line on the back of the unit, or items stored on top of or around the refrigerator.	Normal Operation
	Refrigerator is not resting solidly on the floor.	Floor is weak or uneven or leveling legs need to be adjusted. See the <b>Door Alignment</b> section.
	Refrigerator with linear compressor was jarred while running.	Normal Operation
Whooshing	Evaporator fan motor is circulating air through the refrigerator and freezer compartments.	Normal Operation
	Air is being forced over the condenser by the condenser fan.	Normal Operation
Gurgling	Refrigerant flowing through the cooling system.	Normal Operation
Popping	Contraction and expansion of the inside walls due to changes in temperature.	Normal Operation
Sizzling	Water dripping on the defrost heater during a defrost cycle.	Normal Operation
Vibrating	If the side or back of the refrigerator is touching a cabinet or wall, some of the normal vibrations may make an audible sound.	To eliminate the noise, make sure that the sides and back cannot vibrate against any wall or cabinet.
Dripping	Water running into the drain pan during the defrost cycle.	Normal Operation
Pulsating or High-Pitched Sound	Your refrigerator is designed to run more efficiently to keep your food items at the desired temperature. The high efficiency compressor may cause your new refrigerator to run longer than your old one, but it is still more energy efficient than previous models. While the refrigerator is running, it is normal to hear a pulsating or highpitched sound.	Normal Operation

## TROUBLESHOOTING GUIDE

### PARTS & FEATURES

Problem	Possible Causes	Solutions
Doors will not close correctly or pop open.	Food packages are blocking the door open.	Rearrange food containers to clear the door and door shelves.
	Ice bin, crisper cover, pans, shelves, door bins, or baskets are out of position.	Push bins all the way in and put crisper cover, pans, shelves and baskets into their correct positions. See the <b>Using Your Refrigerator</b> section for more information.
	The doors were removed during product installation and not properly replaced.	Remove and replace the doors according to the <b>Removing and Replacing Refrigerator Handles and Doors</b> section.
	Refrigerator is not leveled properly.	See <b>Door Alignment</b> in the <b>Refrigeration Installation</b> section to level refrigerator.
Doors are difficult to open.	The gaskets are dirty or sticky.	Clean the gaskets and the surfaces that they touch. Rub a thin coat of appliance polish or kitchen wax on the gaskets after cleaning.
	Door was recently closed.	When you open the door, warmer air enters the refrigerator. As the warm air cools, it can create a vacuum. If the door is hard to open, wait one minute to allow the air pressure to equalize, then see if it opens more easily.
Refrigerator wobbles or seems unstable.	Leveling legs are not adjusted properly.	Refer to the <b>Leveling and Door Alignment</b> section.
	Floor is not level.	It may be necessary to add shims under the leveling legs or rollers to complete installation.
Lights do not work.	LED interior lighting failure.	The refrigerator compartment lamp is LED interior lighting, and service should be performed by a qualified technician. Refer to the <b>Light Bulb Replacement</b> section.
The interior of the refrigerator is covered with dust or soot.	The refrigerator is located near a fire source, such as a fireplace, chimney or candle.	Make sure that the refrigerator is not located near a fire source, such as a fireplace, chimney or candle.