

# OWNER'S MANUAL

30" and 36"  
Radiant Cooktops

Para consultar una version en español de este manual de instrucciones, visite nuestro sitio de internet [Monogram.com](http://Monogram.com).

Pour obtenir une version française de ce manuel, visitez notre site Web sur [Monogram.com](http://Monogram.com).

ELEVATE EVERYTHING

**MONOGRAM**

**Introduction**

Your new Monogram cooktop makes an eloquent statement of style, convenience and kitchen planning flexibility. Whether you chose it for its purity of design, assiduous attention to detail—or for both of these reasons—you'll find that your Monogram cooktop's superior blend of form and function will delight you for years to come.

Your Monogram cooktop was designed to provide the flexibility to blend in with your kitchen cabinetry. Its sleek design can be beautifully integrated into the kitchen.

The information on the following pages will help you operate and maintain your cooktop properly.

If you have any questions, visit our Website at: **monogram.com**

**Contents**

|  |    |  |    |
|--|----|--|----|
| <b>Consumer Information</b> . . . . .        | 2  | <b>Griddle</b> . . . . .                 | 15 |
| <b>Safety Information</b> . . . . .          | 4  | <b>Care and Cleaning</b>                 |    |
| <b>Features of Your Cooktop</b> . . . . .    | 6  | Normal Daily Use Cleaning . . . . .      | 16 |
| <b>Using Your Cooktop</b>                    |    | Burned-On Residue . . . . .              | 16 |
| Radiant Glass Cooktop . . . . .              | 8  | Heavy, Burned-On Residue . . . . .       | 16 |
| Home Canning Tips . . . . .                  | 8  | Metal marks and scratches . . . . .      | 17 |
| Cookware for Radiant Glass Cooktop . . . . . | 9  | Glass surface —                          |    |
| For Best Results . . . . .                   | 9  | potential for permanent damage . . . . . | 17 |
| Element Cycling . . . . .                    | 10 | To order parts . . . . .                 | 17 |
| Operating the Cooking Elements . . . . .     | 10 | <b>Troubleshooting Tips</b> . . . . .    | 18 |
| Adjust Burner Size . . . . .                 | 10 | <b>Warranty</b> . . . . .                | 19 |
| Turn Burner(s) Off . . . . .                 | 11 | <b>Consumer Support</b> . . . . .        | 20 |
| Selecting Cooktop Settings . . . . .         | 11 |  |    |
| How To Synchronize Left Elements . . . . .   | 11 |  |    |
| Cooktop Lockout . . . . .                    | 12 |  |    |
| Single Kitchen Timer . . . . .               | 12 |  |    |
| Multiple Timers . . . . .                    | 13 |  |    |
| Hot Light Indicator . . . . .                | 13 |  |    |
| Custom Settings . . . . .                    | 14 |  |    |

**Before using your cooktop**

Read this manual carefully. It is intended to help you operate and maintain your new cooktop properly.  
Keep it handy for answers to your questions.

If you don't understand something or need more help, there is a list of toll-free consumer service numbers included in the back section of this manual.

**OR**

Visit our Website at: **monogram.com**

**Write down the model & serial numbers**

You'll find them on a label under the cooktop. Fill out and return the Consumer Product Registration Card that is packed with this product.

**Before sending in the card, please write the numbers here:**

Model Number

Serial Number

Use these numbers in any correspondence or service calls concerning your cooktop.

*If you  
received a  
damaged  
cooktop*

Immediately contact the dealer (or builder) that sold you the cooktop.

---

*Save time  
& money*

Read this manual. Inside you will find many helpful hints on how to use and maintain your cooktop properly. Just a little preventive care on your part can save you a great deal of time and money over the life of your cooktop.

You'll find many answers to common problems in the Before You Call for Service section. If you review our chart of Troubleshooting Tips first, you may not need to call for service at all.

---

*If you  
need  
service*

To obtain service, see the Consumer Services page in the back of this manual.

We're proud of our service and want you to be pleased. If for some reason you are not happy with the service you receive, here are some steps to follow for further help.

FIRST, contact the people who serviced your appliance. Explain why you are not pleased. In most cases, this will solve the problem.

NEXT, if you are still not pleased, write all the details—including your phone number—to:

Manager, Customer Relations  
Monogram  
Appliance Park  
Louisville, KY 40225

# IMPORTANT SAFETY INFORMATION

## READ ALL INSTRUCTIONS BEFORE USING THE APPLIANCE

### **▲WARNING**

Read all safety instructions before using the product. Failure to follow these instructions may result in fire, electrical shock, serious injury or death.

### **▲WARNING** GENERAL SAFETY INSTRUCTIONS

- Use this cooktop only for its intended purpose as described in this Owner's Manual.
- Be sure your cooktop is properly installed and grounded by a qualified installer in accordance with the provided installation instructions.
- Do not attempt to repair or replace any part of your cooktop unless it is specifically recommended in this manual. All other servicing should be performed by a qualified technician.
- Before performing any service, unplug the cooktop or disconnect the power supply at the household distribution panel by removing the fuse or switching off the circuit breaker.
- Do not leave children alone—children should not be left alone or unattended in an area where the cooktop is in use. They should never be allowed to climb, sit or stand on any part of the cooktop.
- **▲CAUTION** Do not store items of interest to children above the cooktop—children climbing on the cooktop to reach items could be seriously injured.
- Use only dry pot holders—moist or damp pot holders on hot surfaces may result in burns from steam. Do not let pot holders touch hot surface units or heating elements. Do not use a towel or other bulky cloth in place of pot holders.
- Never use your cooktop for warming or heating the room.
- Do not touch surface elements. These surfaces may be hot enough to burn even though they are dark in color. During and after use, do not touch, or let clothing or other flammable materials contact the surface elements or areas nearby the surface elements; allow sufficient time for cooling first.
- Potentially hot surfaces include the cooktop and areas facing the cooktop.
- Do not heat unopened food containers. Pressure could build up and the container could burst, causing an injury.
- Cook meat and poultry thoroughly—meat to at least an internal temperature of 160°F and poultry to at least an internal temperature of 180°F. Cooking to these temperatures usually protects against foodborne illness.

### **▲WARNING** KEEP FLAMMABLE MATERIALS AWAY FROM THE COOKTOP

Failure to do so may result in fire or personal injury.

- Do not store or use flammable materials near the cooktop, including paper, plastic, pot holders, linens, wall coverings, curtains, drapes and gasoline or other flammable vapors and liquids.
- Do not let cooking grease or other flammable materials accumulate in or near the cooktop. Grease on the cooktop may ignite.
- Never wear loose-fitting or hanging garments while using the cooktop. These garments may ignite if they contact hot surfaces causing severe burns.

## READ AND SAVE THESE INSTRUCTIONS

# IMPORTANT SAFETY INFORMATION

## READ ALL INSTRUCTIONS BEFORE USING THE APPLIANCE

---

### **▲WARNING** COOKTOP SAFETY INSTRUCTIONS

- In the event of a fire, do not use water or grease on fires. Never pick up a flaming pan. Turn the controls off. Smother a flaming pan on a surface unit by covering the pan completely with a well-fitted lid, cookie sheet or flat tray. Use a multi-purpose dry chemical or a foam-type fire extinguisher.
- Never leave the surface units unattended at medium or high heat settings. Boilovers cause smoking and greasy spillovers that may catch on fire.
- Never leave oil unattended while frying. If allowed to heat beyond its smoking point, oil may ignite resulting in fire that may spread to surrounding cabinets. Use a deep fat thermometer whenever possible to monitor oil temperature.
- To avoid spillover and fire, use a minimum amount of oil when shallow pan-frying and avoid cooking frozen foods with excessive amounts of ice.
- Use the proper pan size - select cookware having flat bottoms large enough to cover the surface heating element. The use of undersized cookware will expose a portion of the surface unit to direct contact and may result in ignition of clothing. Proper relationship of cookware to surface unit will also improve efficiency.
- To minimize the possibility of burns, ignition of flammable materials and spillage, the handle of a container should be turned toward the center of the range without extending over nearby surface units.

### **▲WARNING** RADIANT COOKTOP SAFETY INSTRUCTIONS

- Only certain types of glass, glass/ceramic, earthenware or other glazed containers are suitable for cooktop service; others may break because of the sudden change in temperature.
- Use care when touching the cooktop. The glass surface of the cooktop will retain heat after the controls have been turned off.
- Do not cook on a broken cooktop. If the glass cooktop should break, cleaning solutions and spillovers may penetrate the broken cooktop and create a risk of electric shock. Contact a qualified technician immediately.
- Avoid scratching the glass cooktop. The cooktop can be scratched with items such as knives, sharp instruments, rings or other jewelry, and rivets on clothing.
- Do not place or store items that can melt or catch fire on the glass cooktop, even when it is not being used. If the cooktop is inadvertently turned on, they may ignite. Heat from the cooktop or oven vent after it is turned off may cause them to ignite also.
- Use CERAMA BRYTE® ceramic Cooktop Cleaner and CERAMA BRYTE® Cleaning Pad to clean the cooktop. Wait until the cooktop cools and the indicator light goes out before cleaning. A wet sponge or cloth on a hot surface can cause steam burns. Some cleaners can produce noxious fumes if applied to a hot surface. Read and follow all instructions and warnings on the cleaning cream label. **NOTE:** Sugary spills are an exception. They should be scraped off while still hot using an oven mitt and a scraper. See the Cleaning the glass cooktop section for detailed instructions.

READ AND SAVE THESE INSTRUCTIONS

### Features

(Throughout this manual, features and appearance may vary.)

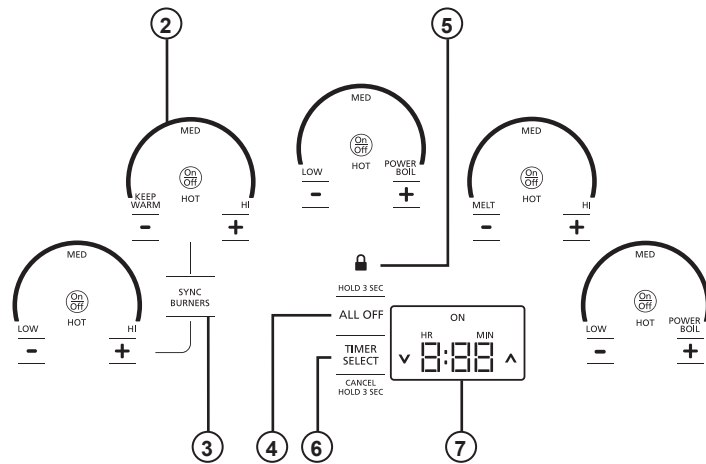
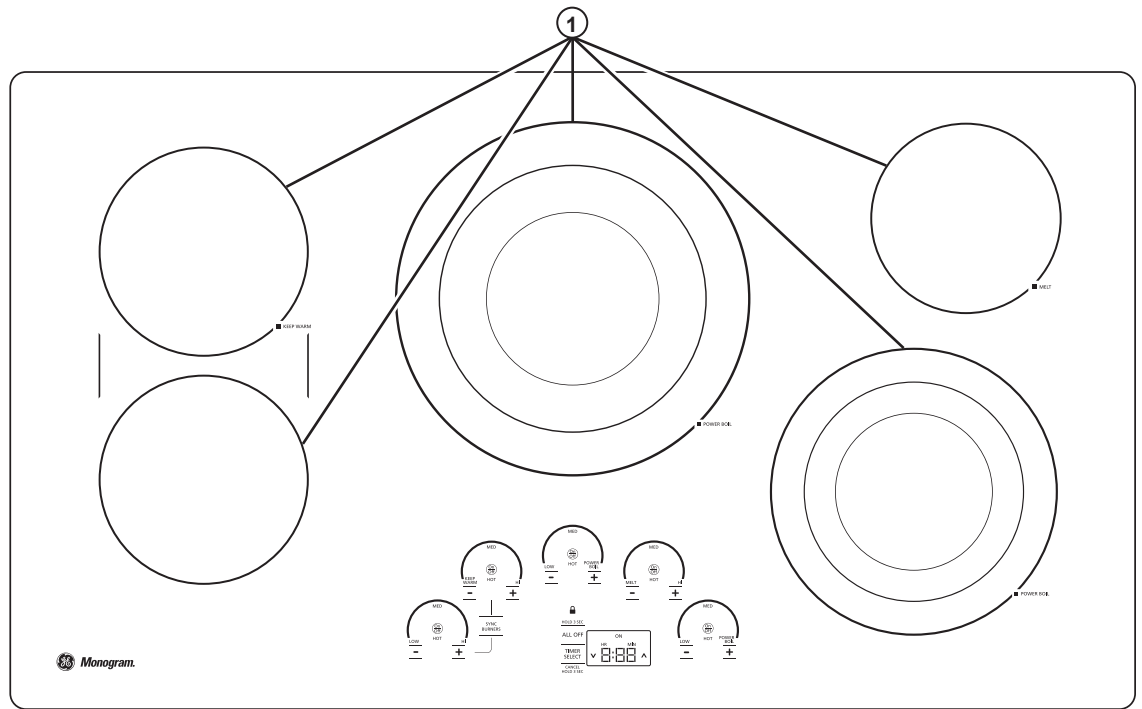

### ZEU36 – 36” Radiant Cooktop”

| Feature Index        | Page |
|----------------------|------|
| 1 Cooking Element(s) | 10   |
| 2 Power Level Arc    | 10   |
| 3 Sync Burners       | 11   |
| 4 All Off            | 11   |
| 5 Lock               | 12   |
| 6 Timer Select       | 12   |
| 7 Display            | 12   |

### Features

(Throughout this manual, features and appearance may vary.)

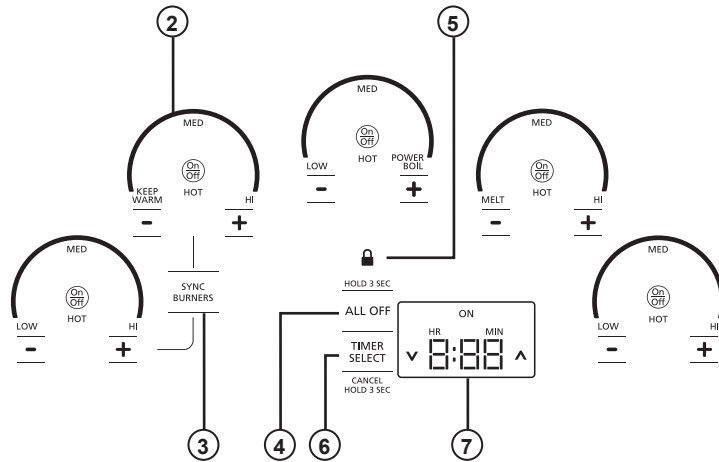
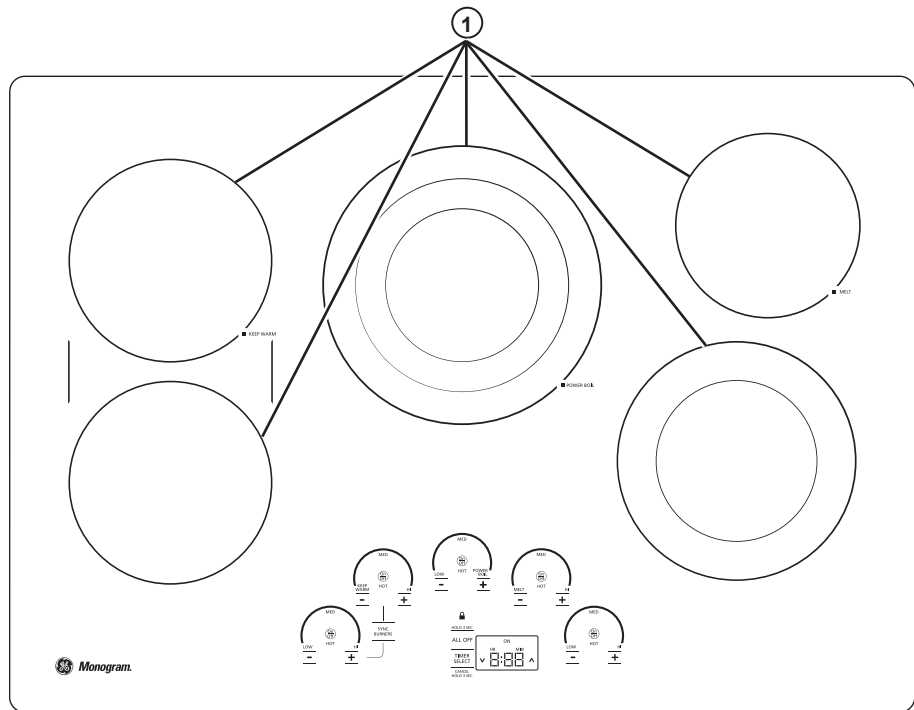

### ZEU30 – 30” Radiant Cooktop

| Feature Index        | Page |
|----------------------|------|
| 1 Cooking Element(s) | 10   |
| 2 Power Level Arc    | 10   |
| 3 Sync Burners       | 11   |
| 4 All Off            | 11   |
| 5 Lock               | 12   |
| 6 Timer Select       | 12   |
| 7 Display            | 12   |

### Radiant Glass Cooktop

The radiant cooktop features heating units beneath a smooth glass surface.

**NOTE:** A slight odor is normal when a new cooktop is used for the first time. It is caused by the heating of new parts and insulating materials and will disappear in a short time.

**NOTE:** This cooktop has Rapid Response surface units. The cooktop will automatically heat up or cool down to the desired power level setting in the quickest time possible. While the surface units are on, you may not see them glow red during certain heat up or cool down conditions.

Cooktop temperatures increase with the number of surface units that are on. With 3 or 4 units turned on, surface temperatures are high. Always use caution when touching the cooktop.



Never cook directly on the glass.  
Always use cookware.

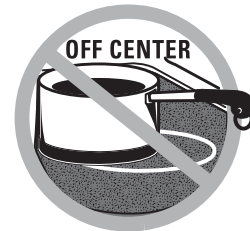

Always place the pan in the center of the surface unit you are cooking on.

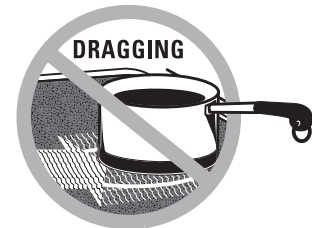

Do not slide cookware across the cooktop because it can scratch the glass—the glass is scratch-resistant, not scratch proof.

### Home Canning Tips

Be sure the canner is centered over the surface unit.

Make sure the canner is flat on the bottom.

To prevent burns from steam or heat, use caution when canning.

Use recipes and procedures from reputable sources. These are available from manufacturers such as Ball® and Kerr® and the Department of Agriculture Extension Service.

Flat-bottomed canners are recommended. Use of water bath canners with rippled bottoms may extend the time required to bring the water to a boil.



## Cookware for Radiant Glass Cooktop

The following information will help you choose cookware which will give good performance on glass cooktops.

**NOTE:** Follow all cookware manufacturer's recommendations when using any type of cookware on the ceramic cooktop.

### **Recommended**

#### **Stainless Steel**

#### **Aluminum:**

heavy weight recommended

Good conductivity. Aluminum residues sometimes appear as scratches on the cooktop but can be removed if cleaned immediately. Because of its low melting point, thin weight aluminum should not be used.

#### **Copper Bottom:**

Copper may leave residues which can appear as scratches. The residues can be removed, as long as the cooktop is cleaned immediately. However, do not let these pots boil dry. Overheated metal can bond to glass cooktops. An overheated copper bottom pot will leave a residue that will permanently stain the cooktop if not removed immediately.

#### **Enamel (painted) on Cast Iron:**

recommended if bottom of pan is coated

### **Avoid/Not Recommended**

#### **Enamel (painted) on Steel:**

Heating empty pans can cause permanent damage to cooktop glass. The enamel can melt and bond to the ceramic cooktop.

#### **Glass-ceramic:**

Poor performance. Will scratch the surface.

#### **Stoneware:**

Poor performance. May scratch the surface.

#### **Cast Iron:**

not recommended—unless designed specifically for glass cooktops

Poor conductivity and slow to absorb heat. Will scratch the cooktop surface.

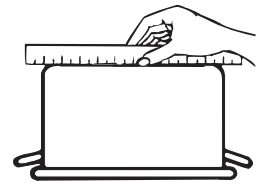

Check pans for flat bottoms by using a straight edge.



Pans with rounded, curved, ridged or warped bottoms are not recommended.

## For Best Results

- Place only dry pans on the surface elements. Do not place lids on the surface elements, particularly wet lids. Wet pans and lids may stick to the surface when cool.
- Do not use woks that have support rings. This type of wok will not heat on glass surface elements.
- We recommend that you use only a flat-bottomed wok. They are available at your local retail store. The bottom of the wok should have the same diameter as the surface element to ensure proper contact.
- Some special cooking procedures require specific cookware such as pressure cookers or deep-fat fryers. All cookware must have flat bottoms and be the correct size.



Do not place wet pans on the glass cooktop.



Do not use woks with support rings on the glass cooktop.



Use flat-bottomed woks on the glass cooktop.

### Element Cycling

Surface elements will cycle on and off to maintain the temperature you have selected. All radiant surface elements have a temperature limiter that protects the glass cooktop from getting too hot, this is normal. The temperature limiter may cycle the elements off more frequently if:

- The pan boils dry.
- The pan bottom is not flat.
- The pan is off-center.
- There is no pan on the element.

### Operating the Cooking Elements

Turn Burner(s) On: Touch and hold **On/Off** pad about half a second. A chime can be heard with each touch to any pad.

Power level can be selected in any of the following ways:

1. **Swipe the gray arc** (on the graphics) to the desired power level. **There is no sensor on the LEDs**, or;
2. Touch **Anywhere** along the gray arc, or;
3. Touch **+** or **-** pads to adjust power level, or;
4. Shortcut to Hi: Immediately after turning unit on, touch the **+** pad, or;
5. Shortcut to Low: Immediately after turning unit on, touch the **-** pad.

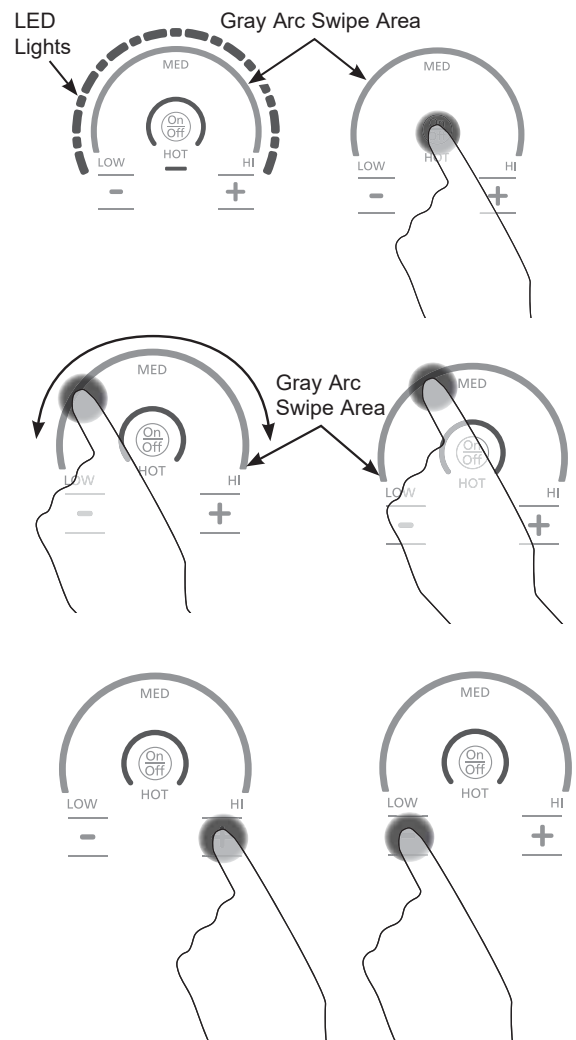

### Adjust Burner Size

The burner ring size is adjustable on some elements. The ring size can be selected by pressing the burner ring graphic.

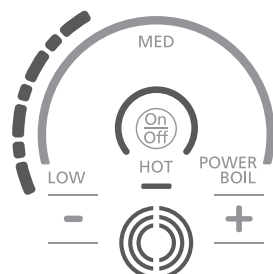

Single Surface Element

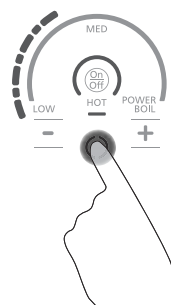

Dual Surface Element

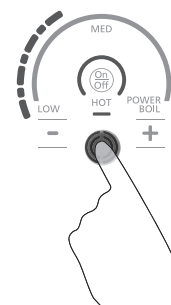

Tri-Ring Surface Element

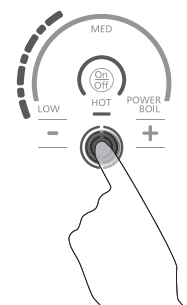

### Turn Burner(s) Off

Touch **On/Off** pad for an individual burner or touch the **All Off** pad.

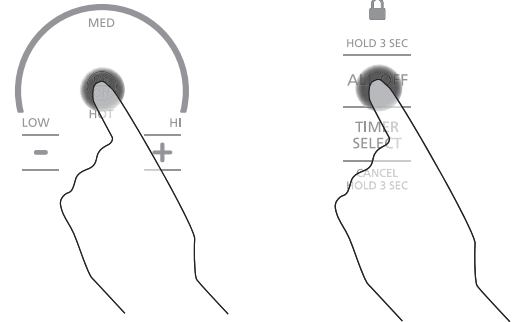

### Selecting Cooktop Settings

Choose the element/burner that is best fit to the cookware size. Each element/burner on your new cooktop has its own power levels ranging from low to high. Power level settings necessary for cooking will vary depending on the cookware being used, the type and quantity of food, and the desired outcome. In general use lower settings for melting, holding and simmering and use higher settings for heating quickly, searing and frying. When keeping foods warm confirm selected setting is sufficient to maintain food temperature above 140°F. Larger elements and elements marked “Keep Warm” are not recommended for melting.

Hi is the highest power level, designed for large quantity rapid cooking and boiling. Hi will operate for a maximum of 10 minutes. Hi may be repeated after the initial 10 minute cycle by pressing the + pad.

**CAUTION:** Do not place any cookware, utensils or leave excess water spills on control key pads. This may result in unresponsive touch pads and turning off the cooktop if present for several seconds.

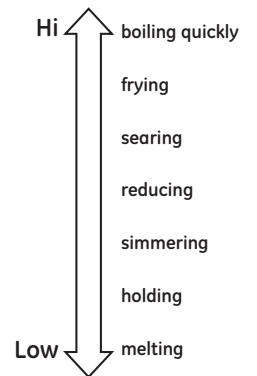

### How To Synchronize Left Elements

**To Turn On**  
Hold the Sync Burners pad for about half a second to connect the two burners. Operate either element as described on page 10 to adjust power level.

**To Turn Off**  
1. Touch the **On/Off** pad on either burner to turn off the Sync Burners.  
or  
2. Touch the **Sync Burners** to turn both burners off.

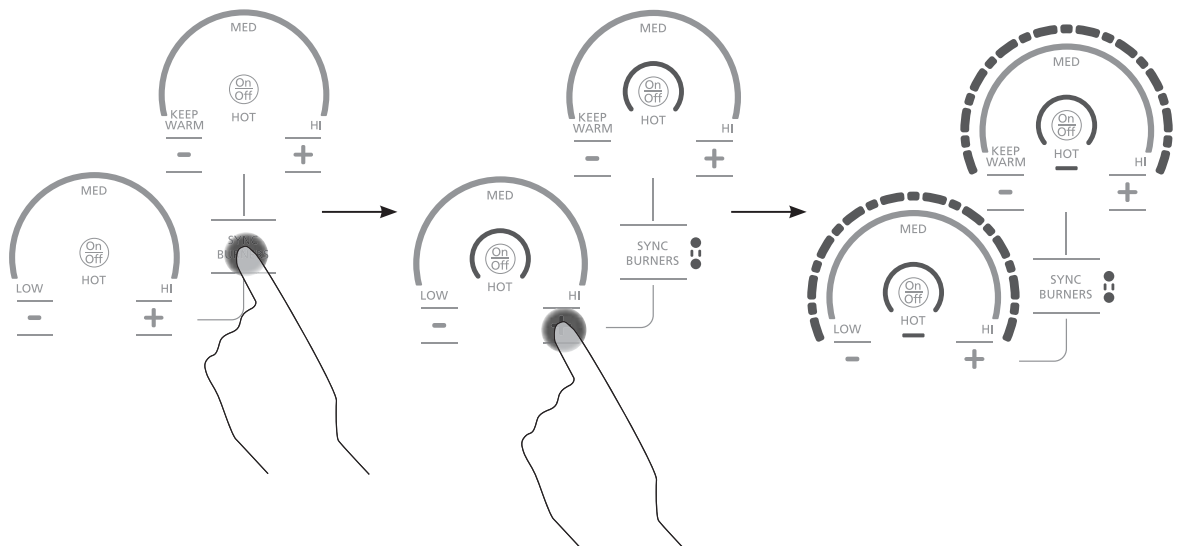

### Cooktop Lockout

#### Lock

Touch **Control Lock** pad for 3 seconds.

#### To Turn Off

Touch **Control Lock** pad again for 3 seconds.

See Custom Settings section to activate Auto Lock feature.

Control Lock Indicator/Symbol



Cooktop Lockout: locks operation of the controls

### Single Kitchen Timer

#### To Turn On

Touch the **Timer Select** pad. Touch the **▲** or **▼** arrows to choose the desired number of minutes. Timer automatically starts 3 seconds after pad is touched. The "ON" LED will appear automatically when timer is set.

**NOTE:** Use the kitchen timer to measure cooking time or as a reminder. The kitchen timer does not control the cooking elements. Timer turns off if there is no activity for 30 seconds.

#### To Turn Off

Hold **Timer Select** pad for 3 seconds to cancel timer. Alarm will sound continuously when time is up until user turns timer off.

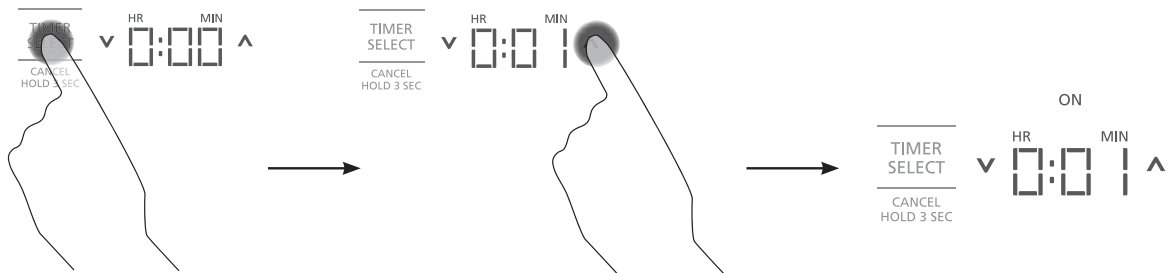

## Multiple Timers

### Timer Mode

For more information see Custom Settings, Timer Mode section for Multi-Timer feature. Each burner can be linked to a timer. Burner must be on to set the timer. When more than one burner is on, the order of the timer is from left to right.

### To Turn ON Multiple Timers

1. Touch the **Timer Select** pad. The corresponding burner power level and the display will blink. Touch the **▲** or **▼** arrows to adjust time. Timer automatically starts after 3 seconds if there is no further action. The "ON" LED will light when timer is on.

2. To set timer for the next burner, touch the **Timer Select** pad. The corresponding burner power level and the display will blink. Touch the **▲** or **▼** arrows to adjust time. Timer automatically starts after 3 seconds if there is no further action. The "ON" LED will light when timer is on. Repeat the steps for the remaining timers.

### To Turn ON Multiple Timers

Hold **Timer Select** pad for 3 seconds to cancel timer. The corresponding burner power level and display will blink. When the burner times out, the corresponding timer also times out.

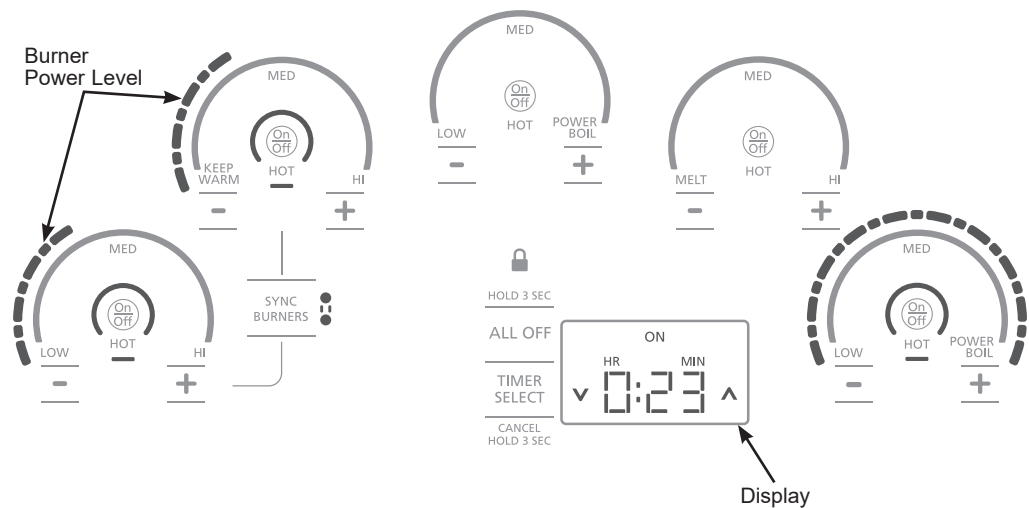

## Hot Light Indicator

A hot surface indicator light (one for each cooking element) will glow when the glass surface is hot and will remain on until the surface has cooled to a temperature that is safe to touch.

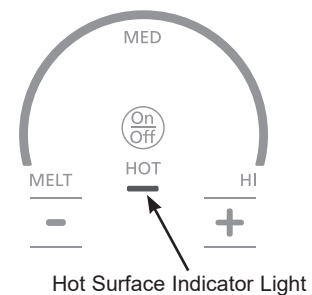

### Custom Settings

1. Press and hold **All Off** pad for 3 seconds, then immediately press and hold the **Timer Select** pad for 3 seconds to enter custom settings. Those two pads must be pressed within 30 seconds. Any other pad will cancel mode.
2. "C - -" appears on display. To navigate through the Custom Settings, use the **▲** (up) or **▼** (down) pads. If **▲** (up) is selected the display cycle starts at "C01". If **▼** (down) is selected, the display cycle starts at "C62".
3. To activate a new Custom Setting the user will touch and hold the **Timer Select** pad for 3 sec. Only ONE of the Custom Setting Choices can be activated for each Custom Setting. The red "On" LED will turn on and a sound will go off once a new custom setting is activated.
4. The cooktop will exit Custom Settings if it is inactive for 3 minutes.
5. To exit Custom Settings and save any changes, touch and hold the **All Off** pad for 3 seconds.

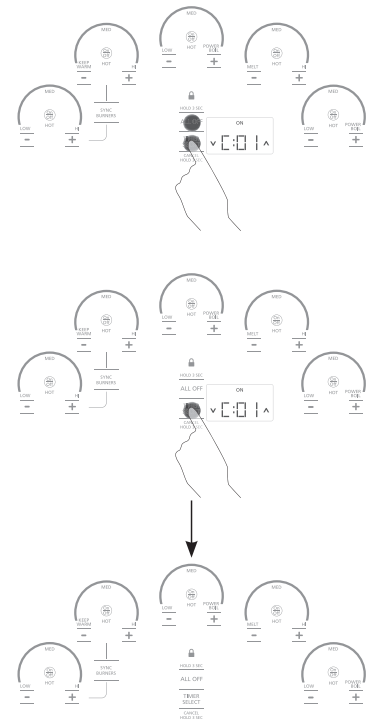

### Custom Settings Chart

| Custom Settings                  | Custom Setting Choices  |
|----------------------------------|---|
| <b>C0 (Factory Settings)</b>     | <b>C01</b> - Factory Reset (Clears customized settings and restores defaults)   |
|                                  | <b>C02</b> - Custom settings activated (Not visible unless any other custom setting is selected. And automatically on when any other custom setting is selected. Not selectable by user.) |
| <b>C1 (Control Lock)</b>         | <b>C11</b> - Standard Lock (ie; Only on when lock button pressed for 3 seconds.) If using a timer, Control Lock is unavailable.   |
|                                  | <b>C12</b> - Auto Lock (ie; Engages after cooktop has been in standby mode for 10 minutes.) The unit should be completely off to go into Auto Lock.                                       |
| <b>C2 (LED light level)</b>      | <b>C21</b> - Full illumination  |
|                                  | <b>C22</b> - Medium illumination  |
|                                  | <b>C23</b> - Lowest illumination  |
| <b>C3 (Button Loudness)</b>      | <b>C31</b> - All sounds activated at 100% (For alarm sounds, 100% = Whatever level is set in c4.)   |
|                                  | <b>C32</b> - Button sound level reduced by 50%, Alarm sounds at 100%  |
|                                  | <b>C33</b> - Button sounds deactivated, Alarm sounds activated at 100%  |
| <b>C4 (Timer Alarm Loudness)</b> | <b>C41</b> - High   |
|                                  | <b>C42</b> - Low  |
| <b>C5 (Timer Alarm Duration)</b> | <b>C51</b> - Indefinite (ie; alarm continues until cancelled by user).  |
|                                  | <b>C52</b> - Alarm sounds for 60 seconds.   |
|                                  | <b>C53</b> - Alarm sounds for 30 seconds.   |
|                                  | <b>C54</b> - Alarm sounds for 15 seconds.   |
| <b>C6 (Timer Mode)</b>           | <b>C61</b> - Single Kitchen Time (Independent of elements.)   |
|                                  | <b>C62</b> - Multi-Timer (Tied to each element.)  |

\* Options in grey are default settings

## Using the Griddle

### ▲ CAUTION Burn Hazard

- Griddle surfaces may be hot enough to cause burns during and after use. Place and remove the griddle when it is cool and all surface units are off. Use oven mitts if you will touch the griddle while hot. Failure to do so can result in burns.
- Place and remove the griddle only when griddle is cool and all surface burners are turned OFF.

Before using this cookware for the first time, wash it to make sure it is clean. Then season it lightly, rubbing cooking oil onto the cooking surface.

### How To Place The Griddle

**IMPORTANT:** Always place and use your griddle at the designated location on the cooktop.

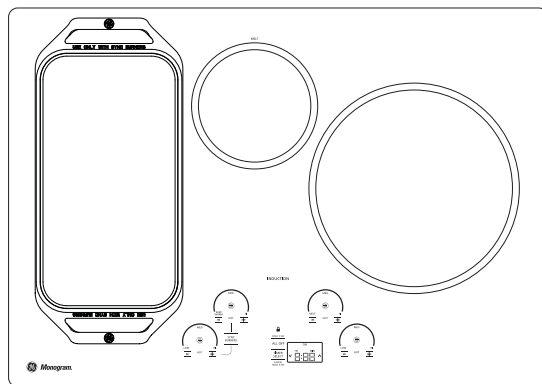

| Type of Food                               | Cook Setting |
|--|--------------|
| Warming Tortillas                          | Med-Lo       |
| Pancakes                                   | Med-Lo       |
| Hamburgers                                 | Med          |
| Fried Eggs                                 | Med-Lo       |
| Breakfast Sausage Links                    | Med          |
| Hot Sandwiches<br>(such as Grilled Cheese) | Med-Lo       |

Griddle settings are intended to be a guideline and may need to be adjusted based on individual cooking preferences.

### Griddle Operation

To turn on the surface units for the entire griddle, use the Sync Burner control feature. Touch the **Sync Burner** pad and then adjust power level to desired setting as described on page 10.

### IMPORTANT NOTES:

- Clean the griddle with a sponge and mild detergent in warm water. DO NOT use blue or green scrubbing pads or steel wool.
- Avoid cooking extremely greasy foods and be careful of grease spillover while cooking.
- Never place or store any items on the griddle, even when it is not in use. The griddle can become heated when using the surrounding surface units.
- Avoid using metal utensils with sharp points or rough edges, which might damage the griddle. Do not cut foods on the griddle.
- Do not use cookware as a storage container for food or oil. Permanent staining and/or craze lines could result.
- Your griddle will discolor over time with use.
- Do not clean the griddle in a self-cleaning oven.
- Always allow the cookware to cool before immersing in water.
- Do not overheat the griddle.

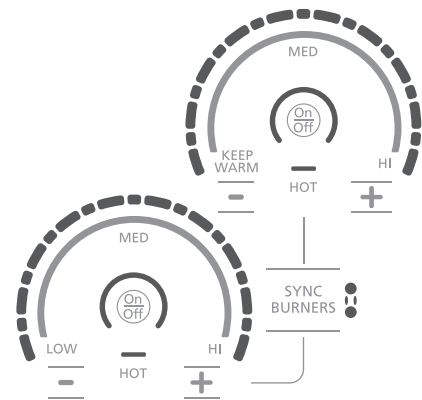

### Normal Daily Use Cleaning

ONLY use CERAMA BRYTE® Ceramic Cooktop Cleaner on the glass cooktop. Other creams may not be as effective.

To maintain and protect the surface of your glass cooktop, follow these steps:

1. Before using the cooktop for the first time, clean it with CERAMA BRYTE® Ceramic Cooktop Cleaner. This helps protect the top and makes cleanup easier.
2. Daily use of CERAMA BRYTE® Ceramic Cooktop Cleaner will help keep the cooktop looking new.
3. Shake the cleaning cream well. Apply a few drops of CERAMA BRYTE® Ceramic Cooktop Cleaner directly to the cooktop.
4. Use a paper towel or CERAMA BRYTE® Cleaning Pad for Ceramic Cooktops to clean the entire cooktop surface.

5. Use a dry cloth or paper towel to remove all cleaning residue. No need to rinse.

**NOTE:** It is very important that you DO NOT heat the cooktop until it has been cleaned thoroughly.



Clean your cooktop after each spill. Use CERAMA BRYTE® Ceramic Cooktop Cleaner.

### Burned-On Residue

**NOTE:** DAMAGE to your glass surface may occur if you use scrub pads other than those recommended.

1. Allow the cooktop to cool.
2. Spread a few drops of CERAMA BRYTE® Ceramic Cooktop Cleaner on the entire burned residue area.
3. Using the included CERAMA BRYTE® Cleaning Pad for Ceramic Cooktops, rub the residue area, applying pressure as needed.
4. If any residue remains, repeat the steps listed above as needed.

5. For additional protection, after all residue has been removed, polish the entire surface with CERAMA BRYTE® Ceramic Cooktop Cleaner and a paper towel.

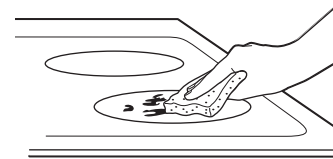

Use a CERAMA BRYTE® Cleaning Pad for Ceramic Cooktops.

### Heavy, Burned-On Residue

1. Allow the cooktop to cool.
2. Use a single-edge razor blade scraper at approximately a 45° angle against the glass surface and scrape the soil. It will be necessary to apply pressure to the razor scraper in order to remove the residue.
3. After scraping with the razor scraper, spread a few drops of CERAMA BRYTE® Ceramic Cooktop Cleaner on the entire burned residue area. Use the CERAMA BRYTE® Cleaning Pad to remove any remaining residue.
4. For additional protection, after all residue has been removed, polish the entire surface with CERAMA BRYTE® Ceramic Cooktop Cleaner and a paper towel.

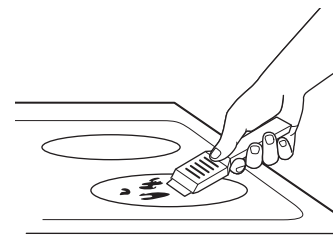

The CERAMA BRYTE® Ceramic Cooktop Scraper and all recommended supplies are available through our Parts Center. See instructions under "Assistance / Accessories" section.

**NOTE:** Do not use a dull or nicked blade.



#### *Metal marks and scratches*

1. Be careful not to slide pots and pans across your cooktop. It will leave metal markings on the cooktop surface.

These marks are removable using the CERAMA BRYTE® Ceramic Cooktop Cleaner with the CERAMA BRYTE® Cleaning Pad for Ceramic Cooktops.

2. If pots with a thin overlay of aluminum or copper are allowed to boil dry, the overlay may leave black discoloration on the cooktop.

This should be removed immediately before heating again or the discoloration may be permanent.

**WARNING:** Carefully check the bottom of pans for roughness that would scratch the cooktop.

---

#### *Glass surface — potential for permanent damage*

*Our testing shows that if you are cooking high sugar mixtures such as jelly or fudge and have a spillover, it can cause permanent damage to the glass surface unless the spillover is immediately removed.*

#### **Damage from sugary spills and melted plastic:**

1. Turn off all surface elements. Remove hot pans.
2. Wearing an oven mitt:
  - a. Use a single-edge razor blade scraper (CERAMA BRYTE® Ceramic Cooktop Scraper) to move the spill to a cool area on the cooktop.
  - b. Remove the spill with paper towels.

3. Any remaining spillover should be left until the surface of the cooktop has cooled.
4. Don't use the surface elements again until all of the residue has been completely removed.

**NOTE:** If pitting or indentation in the glass surface has already occurred, the cooktop glass will have to be replaced. In this case, service will be necessary.

---

#### *To order parts*

To order CERAMA BRYTE® Ceramic Cooktop Cleaner and the cooktop scraper, please call our toll-free number:

**National Parts Center 800.444.1845**

**CERAMA BRYTE® Ceramic Cooktop Cleaner**..... # WX10X300

**CERAMA BRYTE® Ceramic Cooktop Scraper** ..... # WX10X0302

**Kit**..... # WB64X5027  
(Kit includes cream and cooktop scraper)

**CERAMA BRYTE® Cleaning Pads for Ceramic Cooktops** ..... # WX10X350

**Replacement Griddle (for any model that has "Sync Burners")** ..... # JXGRIDL1

**Stainless Steel Cleaner and Polisher** ..... # PM10X311

## Troubleshooting Tips

### Radiant Cooktop

### Before you call for service

Save time and money! Review the charts on the following pages first and you may not need to call for service.

| Problem  | Possible Causes  | What To Do   |
|--|--|--|
| Surface elements will not maintain a rolling boil or cooking is slow | Improper cookware being used.  | Use pans that are absolutely flat and match the diameter of the surface unit selected.   |
| Surface elements do not work properly                                | Cooktop controls improperly set.   | Check to be sure the correct control is set for the surface element you are using.   |
| Power arc ON indicator blinking                                      | +, -, or control lock pads have been touched before an element is turned on.   | See the Operating the Cooking Elements section.  |
| Scratches on cooktop glass surface                                   | Incorrect cleaning methods being used.   | Use recommended cleaning procedures. See the Cleaning the glass cooktop section.   |
|  | Cookware with rough bottoms being used or coarse particles (salt or sand) were between the cookware and the surface of the cooktop. Cookware has been slid across the cooktop surface. | To avoid scratches, use the recommended cleaning procedures. Make sure bottoms of cookware are clean before use, and use cookware with smooth bottoms. |
| Areas of discoloration on the cooktop                                | Food spillovers not cleaned before next use.   | See the Cleaning the glass cooktop section.  |
|  | Hot surface on a model with a light-colored glass cooktop.   | This is normal. The surface may appear discolored when it is hot. This is temporary and will disappear as the glass cools.                             |
| Plastic melted to the surface  | Hot cooktop came into contact with plastic placed on the hot cooktop.  | See the Glass surface – potential for permanent damage section in the Cleaning the glass cooktop section.  |
| Pitting (or indentation) of the cooktop                              | Hot sugar mixture spilled on the cooktop.  | Call a qualified technician for replacement.   |
| Unresponsive keypad  | Keypad is dirty.   | Clean the keypad.  |
|  | A fuse in your home may be blown or the circuit breaker tripped.   | Replace the fuse or reset the circuit breaker.   |

**YOUR MONOGRAM COOKTOP WARRANTY**

**Staple your receipt here. Proof of the original purchase date is needed to obtain service under the warranty.**

**WHAT IS COVERED**

*From the Date of the Original Purchase*

**LIMITED TWO-YEAR WARRANTY**

For two years from date of original purchase, we will provide, free of charge, parts and service labor in your home to repair or replace **any part of the cooktop** that fails because of a manufacturing defect.

This warranty is extended to the original purchaser and any succeeding owner for products purchased for ordinary home use in the 48 mainland states, Hawaii, Washington, D.C. or Canada. If the product is located in an area where service by a Monogram Authorized Servicer is not available, you may be responsible for a trip charge or you may be required to bring the product to an Authorized Monogram Service location for service. In Alaska the warranty is the same except that it is LIMITED because you must pay to ship the product to the service shop or for the service technician's travel costs to your home.

All warranty service will be provided by our Factory Service Centers or by our authorized Customer Care® servicers during normal working hours.

Should your appliance need service, during warranty period or beyond, in the USA call 800.444.1845. In Canada: 888.880.3030. Please have your serial number and model number available when calling for service.

**WHAT IS NOT COVERED**

- Service trips to your home to teach you how to use the product.
- Improper installation, delivery or maintenance. If you have an installation problem, contact your dealer or installer. You are responsible for providing adequate electrical, gas, exhausting and other connecting facilities as described in the Installation Instructions provided with the product.
- Replacement of house fuses or resetting of circuit breakers.
- Damage to the product due to misuse or abuse.
- Failure of the product if it is used for other than its intended purpose or used commercially.
- Damage to product caused by accident, fire, floods or acts of God.
- Incidental or consequential damage caused by possible defects with this appliance.
- Damage caused after delivery.
- Product not accessible to provide required service.

**EXCLUSION OF IMPLIED WARRANTIES**

Your sole and exclusive remedy is product repair as provided in this Limited Warranty. Any implied warranties, including the implied warranties of merchantability or fitness for a particular purpose, are limited to one year or the shortest period allowed by law.

Some states do not allow the exclusion or limitation of incidental or consequential damages, so the above limitation or exclusion may not apply to you. This warranty gives you specific legal rights, and you may also have other rights which vary from state to state.

To know what your legal rights are in your state, consult your local or state consumer affairs office or your state's Attorney General.

**Warrantor: GE Appliances, a Haier company**

**Warrantor in Canada: MC Commercial, Burlington, ON, L7R 5B6**

---

***With the purchase of your new Monogram appliance, receive the assurance that if you ever need information or assistance from Monogram, we will be there. All you have to do is call!***

---

***Register Your Appliance***

Register your new appliance on-line at your convenience! Timely product registration will allow for enhanced communication and prompt service under the terms of your warranty, should the need arise. You may also mail in the pre-printed registration card included in the packing material.  
In the US: **Monogram.com**  
In Canada: **Prodsupport.mabe.ca/crm/Products/ProductRegistration.aspx**

---

***Schedule Service***

Expert Monogram repair service is only one step away from your door. Get on-line and schedule your service at your convenience any day of the year.  
In the US: **Monogram.com**  
or call 800.444.1845 during normal business hours.  
In Canada: **GEAppliances.ca/en/support/service-request** or call 888.880.3030

---

***Extended Warranties***

Purchase a Monogram extended warranty and learn about special discounts that are available while your warranty is still in effect.  
In the US: **Monogram.com**  
or call 800.444.1845 during normal business hours.  
In Canada: **GEAppliances.ca/en/support/purchase-extended-warranty** or call 888.880.3030

---

***Remote Connectivity***

For assistance with wireless network connectivity (for models with remote enable), visit our website at **Monogram.com** or call 800.444.1845 in the US only.

---

***Parts and Accessories***

Individuals qualified to service their own appliances can have parts or accessories sent directly to their homes (VISA, MasterCard and Discover cards are accepted). Order on-line today 24 hours every day.  
In the US: **Monogram.com** or by phone at 800.444.1845 during normal business hours.

**Instructions contained in this manual cover procedures to be performed by any user. Other servicing generally should be referred to qualified service personnel. Caution must be exercised, since improper servicing may cause unsafe operation.**

Customers in Canada should consult the yellow pages for the nearest MC Commercial service center, visit our website at **GEAppliances.ca/en/products/parts-filters-accessories** or call 888.880.3030.