

WASHER INSTALLATION INSTRUCTIONS

INSTRUCTIONS POUR L'INSTALLATION DE LA LAVEUSE

Table of Contents

WASHER SAFETY1

INSTALLATION REQUIREMENTS.....2

 Tools and Parts2

 Location Requirements2

 Drain System3

 Electrical Requirements4

INSTALLATION INSTRUCTIONS.....4

 Before you start: remove shipping materials4

 Connect Drain Hose.....5

 Connect Inlet Hoses.....6

 Level Washer7

 Complete Installation Checklist.....8

Table des matières

SÉCURITÉ DE LA LAVEUSE9

EXIGENCES D'INSTALLATION9

 Outillage et pièces9

 Exigences d'emplacement10

 Système de vidange.....11

 Spécifications électriques.....11

INSTRUCTIONS D'INSTALLATION12

 Avant de commencer : retrait du matériel d'expédition ...12

 Raccordement du tuyau de vidange.....13

 Raccordement des tuyaux d'arrivée d'eau14

 Établissement de l'aplomb de la laveuse.....15

 Liste de vérification pour l'achèvement de l'installation COUVERTURE ARRIÈRE

Para obtener acceso al instrucciones de instalación en español, o para obtener información adicional acerca de su producto, visite: www.whirlpool.com

INSTALLATION NOTES

Date of purchase: _____

Date of installation: _____

Installer: _____

Model number: _____

Serial number: _____

NOTES SUR L'INSTALLATION

Date d'achat : _____

Date d'installation : _____

Installateur : _____

Numéro de modèle : _____

Numéro de série : _____

WASHER SAFETY

Your safety and the safety of others are very important.

We have provided many important safety messages in this manual and on your appliance. Always read and obey all safety messages.



This is the safety alert symbol.

This symbol alerts you to potential hazards that can kill or hurt you and others.

All safety messages will follow the safety alert symbol and either the word "DANGER" or "WARNING."

These words mean:

⚠ DANGER

You can be killed or seriously injured if you don't immediately follow instructions.

⚠ WARNING

You can be killed or seriously injured if you don't follow instructions.

All safety messages will tell you what the potential hazard is, tell you how to reduce the chance of injury, and tell you what can happen if the instructions are not followed.

INSTALLATION REQUIREMENTS

Tools and Parts

Gather required tools and parts before starting installation.

Tools needed:

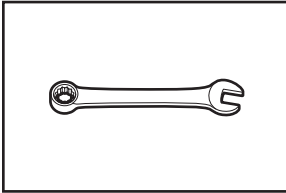

Adjustable or open end wrench $\frac{9}{16}$ " (14 mm)

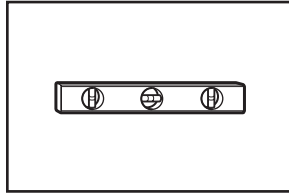

Level

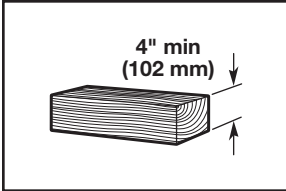

Wood block

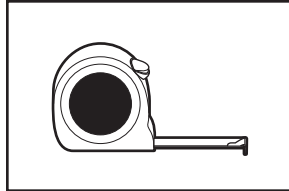

Ruler or measuring tape

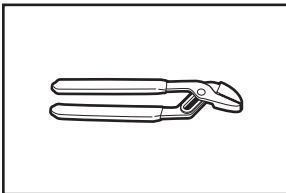

Pliers that open to $1\frac{3}{4}$ " (44.5 mm)

Optional tools:

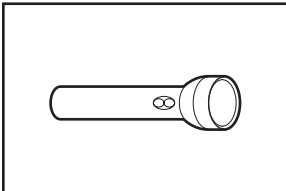

Flashlight

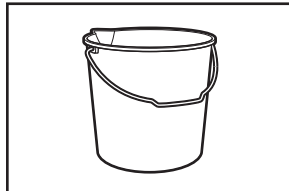

Bucket

Parts supplied:

NOTE: All parts supplied for installation are in cardboard insert in the top of the washer.

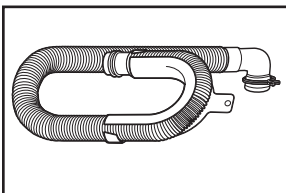

Drain hose with clamp, U-form, and cable tie

Parts needed: (Not supplied with washer)

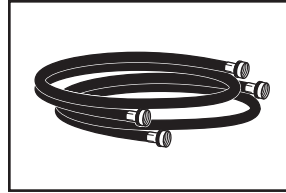

Inlet hoses with flat washers

To order, please refer to toll-free phone numbers on back page of your Use and Care Guide.

- 8212656RP 10 ft. (3.0 m) Inlet hose, Black EPDM (2 pack)
- 8212641RP 5 ft. (1.5 m) Inlet hose, Black EPDM (2 pack)
- 8212646RP 4 ft. (1.2 m) Inlet hose, Black EPDM (2 pack)
- 8212545RP 5 ft. (1.5 m) Inlet hose, Red and Blue EPDM (2 pack)
- 8212487RP 5 ft. (1.5 m) Nylon braided inlet hose (2 pack)
- 8212638RP 6 ft. (1.8 m) Nylon braided inlet hose, space saving 90° elbow, hydro-blue steel couplings (2 pack)
- 8212637RP 6 ft. (1.8 m) Inlet hose, Black EPDM, space saving 90° elbow, hydro-blue steel couplings (2 pack)

Alternate parts: (Not supplied with washer)

Your installation may require additional parts. To order, please refer to toll-free numbers on back page of your Use and Care Guide.

If you have:

Overhead sewer

1" (25 mm) standpipe

Drain hose too short

Lint clogged drain

You will need:

Standard 20 gal. (76 L) 39" (990 mm) tall drain tub or utility sink, sump pump and connectors (available from local plumbing suppliers)

2" (51 mm) diameter to 1" (25 mm) diameter Standpipe Adapter Part Number 3363920
Connector Kit Part Number 285835

Extension Drain Hose Part Number 285863
Connector Kit Part Number 285835

Drain Protector Part Number 367031
Connector Kit Part Number 285835

LOCATION REQUIREMENTS

Select proper location for your washer to improve performance and minimize noise and possible "washer walk". Install your washer in a basement, laundry room, closet, or recessed area.

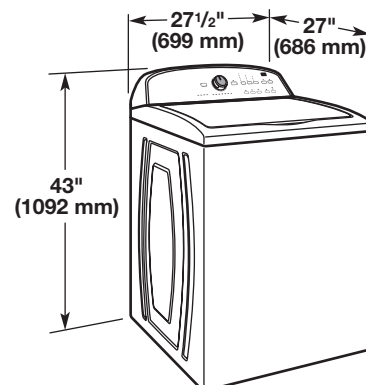

You will need:

- A water heater set to 120°F (49°C).
- A grounded electrical outlet located within 4 ft (1.2 m) of power cord on back of washer.
- Hot and cold water faucets located within 3 ft (0.9 m) of hot and cold water fill valves on washer, and water pressure of 20-100 psi (138-690 kPa).
- A level floor with maximum slope of 1" (25 mm) under entire washer. Installing on carpet is not recommended.
- Floor must support washer's total weight (with water and load) of 315 lbs (143 kgs).

IMPORTANT: Do not install, store, or operate washer where it will be exposed to weather or in temperatures below 32° F (0° C). Water remaining in washer after use may cause damage in low temperatures. See "Washer Care" in your Use and Care Guide for winterizing information.

Proper installation is your responsibility.

Recessed area or closet installation

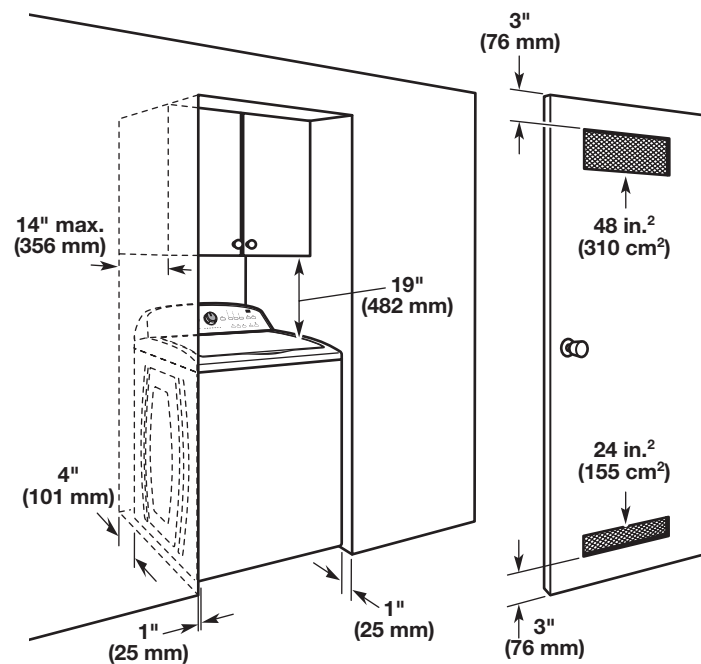

Dimensions show recommended spacing allowed, except for closet door ventilation openings which are minimum required. This washer has been tested for installation with spacing of 0" (0 mm) clearance on the sides. Consider allowing more space for ease of installation and servicing, and spacing for companion appliances and clearances for walls, doors, and floor moldings. Add spacing of 1" (25 mm) on all sides of washer to reduce noise transfer. If a closet door or louvered door is installed, top and bottom air openings in door are required.

DRAIN SYSTEM

Drain system can be installed using a floor drain, wall standpipe, floor standpipe, or laundry tub. Select method you need.

Floor standpipe drain system

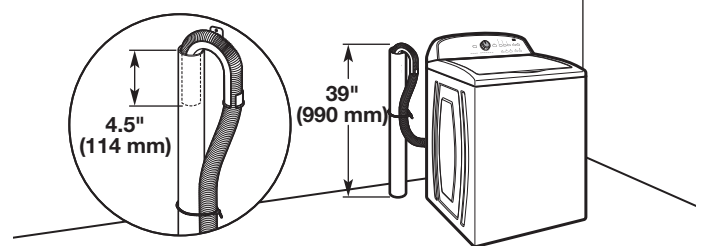

Minimum diameter for a standpipe drain: 2" (51 mm). Minimum carry-away capacity: 17 gal. (64 L) per minute. Top of standpipe must be at least 39" (990 mm) high; install no higher than 96" (2.44 m) from bottom of washer. If you must install higher than 96" (2.44 m), you will need a sump pump system.

Wall standpipe drain system

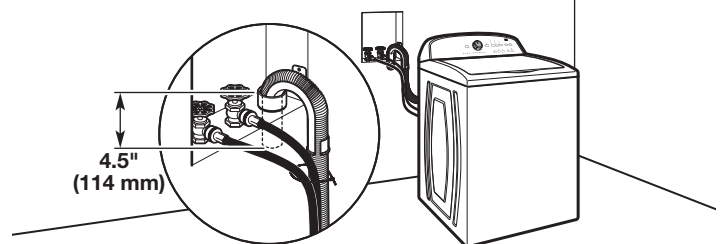

See requirements for floor standpipe drain system.

Floor drain system

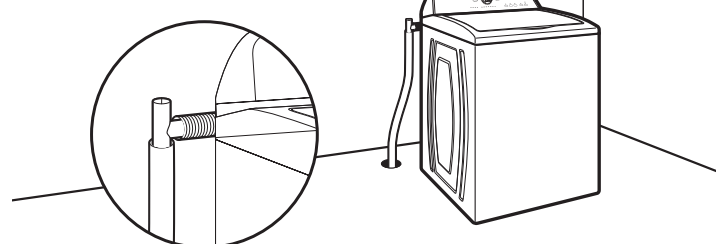

Floor drain system requires a Siphon Break Kit (Part Number 285834), 2 Connector Kits (Part Number 285835), and an Extension Drain Hose (Part Number 285863) that may be purchased separately. To order, please see toll-free phone numbers in your Use and Care Guide. Minimum siphon break: 28" (710 mm) from bottom of washer. (Additional hoses may be needed.)

Laundry tub drain system

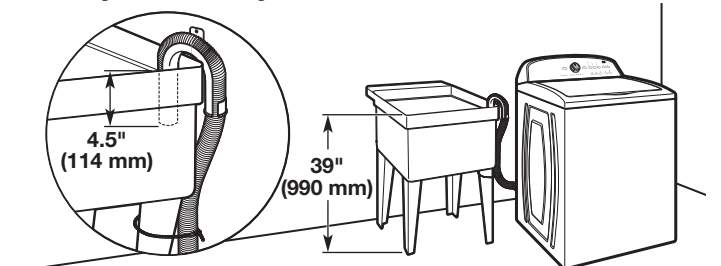

Minimum capacity: 20 gal. (76 L). Top of laundry tub must be at least 39" (990 mm) above floor; install no higher than 96" (2.44 m) from bottom of washer.

IMPORTANT: To avoid siphoning, no more than 4.5" (114 mm) of drain hose should be inside standpipe or below the top of wash tub. Secure drain hose with cable tie.

ELECTRICAL REQUIREMENTS

⚠ WARNING



Electrical Shock Hazard

Plug into a grounded 3 prong outlet.

Do not remove ground prong.

Do not use an adapter.

Do not use an extension cord.

Failure to follow these instructions can result in death, fire, or electrical shock.

- A 120 V, 60 Hz, AC only, 15 or 20 A, fused electrical supply is required. A time-delay fuse or circuit breaker is recommended. It is recommended that a separate circuit breaker serving only this appliance be provided.
- This washer is equipped with a power supply cord having a 3 prong grounding plug.
- To minimize possible shock hazard, the cord must be plugged into a mating, 3 prong, grounding-type outlet, grounded in accordance with local codes and ordinances. If a mating outlet is not available, it is the personal responsibility and obligation of the customer to have the properly grounded outlet installed by a qualified electrician.
- If codes permit and a separate ground wire is used, it is recommended that a qualified electrician determine that the ground path is adequate.
- Do not ground to a gas pipe.
- Check with a qualified electrician if you are not sure the washer is properly grounded.
- Do not have a fuse in the neutral or ground circuit.

GROUNDING INSTRUCTIONS

For a grounded, cord-connected washer:

This washer must be grounded. In the event of a malfunction or breakdown, grounding will reduce the risk of electrical shock by providing a path of least resistance for electric current. This washer is equipped with a cord having an equipment-grounding conductor and a grounding plug. The plug must be plugged into an appropriate outlet that is properly installed and grounded in accordance with all local codes and ordinances.

WARNING: Improper connection of the equipment-grounding conductor can result in a risk of electric shock. Check with a qualified electrician or serviceman if you are in doubt as to whether the appliance is properly grounded.

Do not modify the plug provided with the appliance – if it will not fit the outlet, have a proper outlet installed by a qualified electrician.

For a permanently connected washer:

This washer must be connected to a grounded metal, permanent wiring system, or an equipment grounding conductor must be run with the circuit conductors and connected to the equipment-grounding terminal or lead on the appliance.

INSTALLATION INSTRUCTIONS

⚠ WARNING

Excessive Weight Hazard

Use two or more people to move and install washer.

Failure to do so can result in back or other injury.

Before you start: remove shipping materials

It is necessary to remove all shipping materials for proper operation and to avoid excessive noise from washer.

1. Move washer

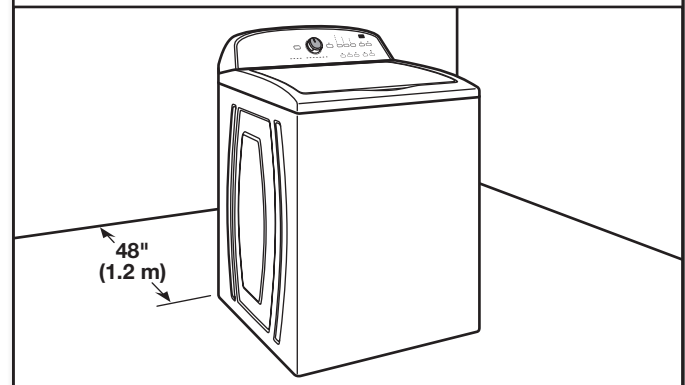

Move washer to within 4 ft (1.2 m) of its final location; it must be in a fully upright position.

NOTE: To avoid floor damage, set washer onto cardboard before moving it and make sure lid is taped shut.

2. Remove shipping base

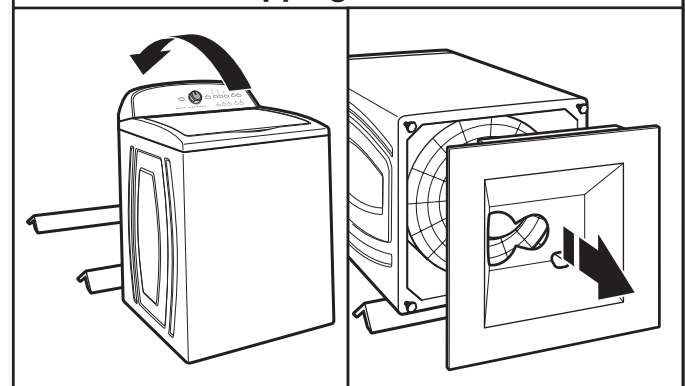

To avoid damaging floor, place cardboard supports from shipping carton on floor behind washer. Tip washer back and place on cardboard supports. Remove shipping base. Set washer upright.

IMPORTANT: Removing shipping base is necessary for proper operation. If your washer includes a sound shield, please refer to the instructions included with the sound shield to install it at this time.

3. Remove packing tray from tub

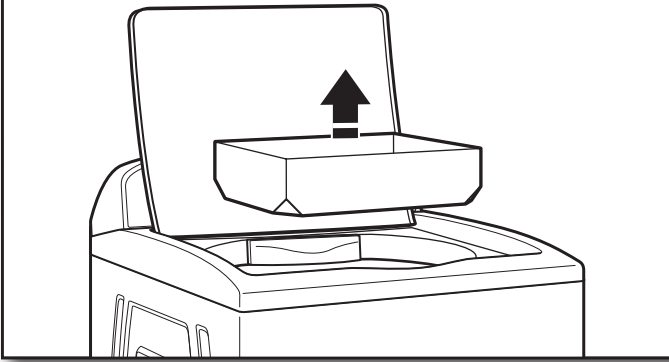

Remove tape from washer lid, open lid and remove all cardboard or styrofoam packing tray from tub. Remove all other packaging materials from washer tub. Be sure to remove all parts from tray.

NOTE: Keep tray in case you need to move washer later.

4. Free power cord

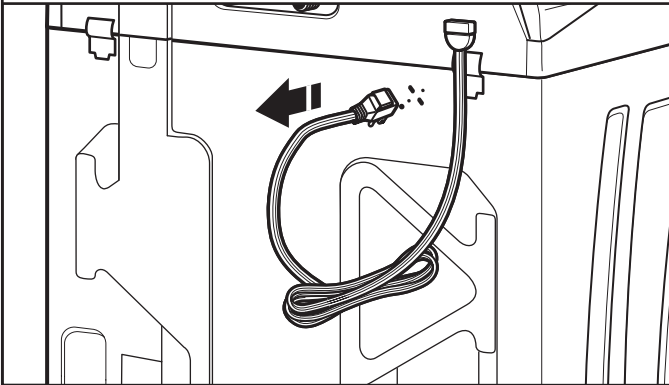

Firmly grasp power cord plug and pull to free from rear panel. Gently place power cord over console to allow free access to back of washer.

CONNECT DRAIN HOSE

5. Attach drain hose to drain port

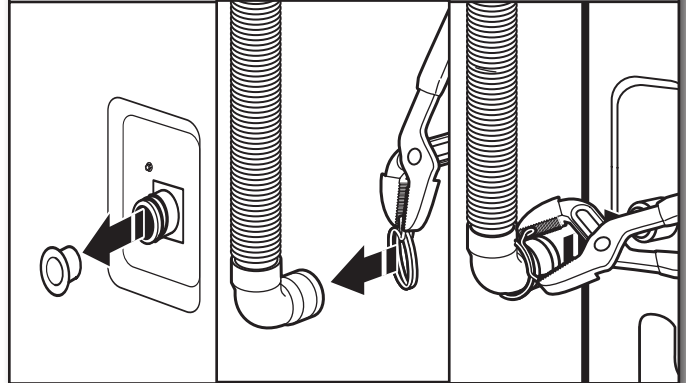

Remove the red plastic plug from the black drain port on the back of the washer.

If clamp is not already in place on elbow end of drain hose, slide it over end as shown. Squeeze clamp with pliers and slide black elbow end of drain hose onto black drain port and secure with clamp.

For a laundry tub or standpipe drain, go to step 6.

For a floor drain, remove the preinstalled drain hose form as shown in Step 7. You may need additional parts with separate directions. See "Tools and Parts".

6. Place drain hose in standpipe

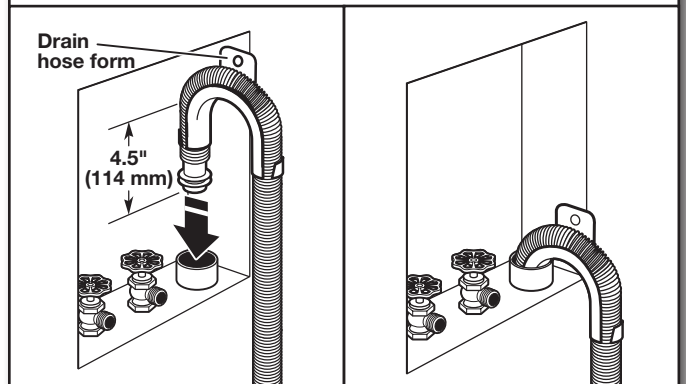

Place hose into standpipe (shown in picture) or over side of laundry tub.

IMPORTANT: 4.5" (114 mm) of drain hose should be inside standpipe; do not force excess hose into standpipe or lay on bottom of laundry tub. Drain hose form must be used.

7. Remove drain hose form (floor drain installations only)

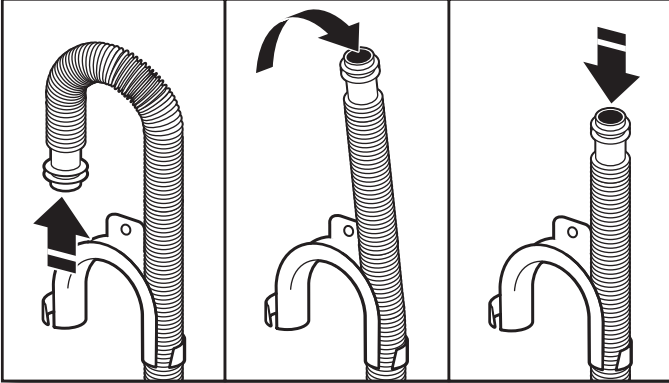

For floor drain installations, you will need to remove the drain hose form from the end of the drain hose. You may need additional parts with separate directions. See "Tools and Parts".

CONNECT INLET HOSES

Washer must be connected to water faucets with new inlet hoses with flat washers (not provided). Do not use old hoses.

NOTE: Both hoses must be attached and have water flowing to inlet valves. If you are only connecting to a cold water faucet, you must use a Y-adaptor (not provided).

8. Connect inlet hoses to water faucets

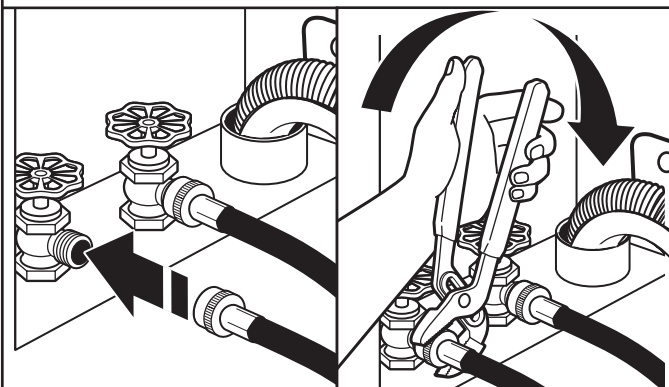

Attach hose to hot water faucet. Screw on coupling by hand until it is seated on washer. Use pliers to tighten couplings an additional two-thirds turn. Repeat this step with second hose for cold water faucet.

IMPORTANT: Do not overtighten or use tape or sealants on valve when attaching to faucets or washer. Damage can result.

9. Clear water lines

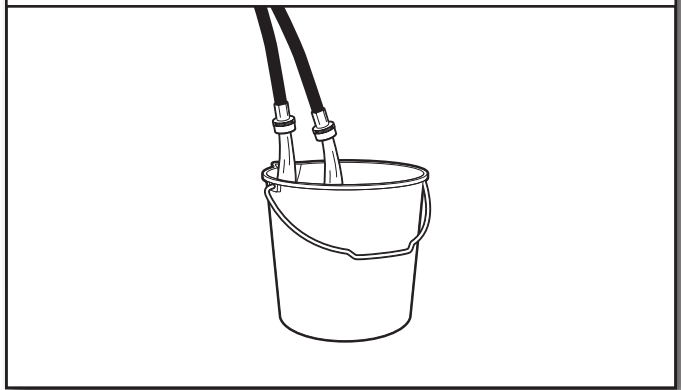

Run water for a few seconds through hoses into a laundry tub, drainpipe, or bucket to avoid clogs. Water should run until clear.

Make note of which hose is connected to hot water to help in attaching hoses to washer correctly.

10. Connect inlet hoses to washer

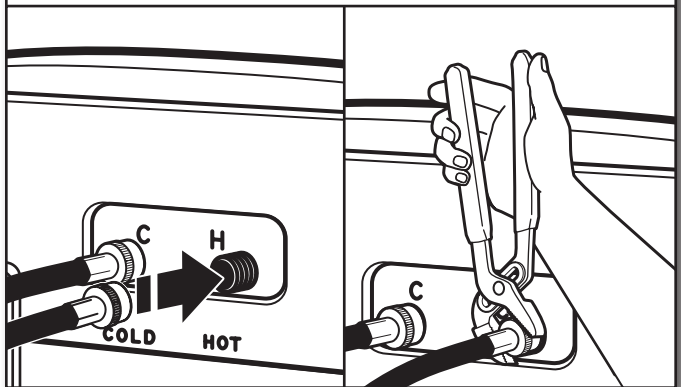

Attach hot water hose to hot water inlet valve marked with a red ring. Screw coupling by hand until it is snug. Use pliers to tighten couplings an additional two-thirds turn. Repeat with cold water inlet valve.

IMPORTANT: To reduce risk of hose failure, replace the hoses every 5 years. Record hose installation or replacement dates for future reference.

■ Periodically inspect and replace hoses if bulges, kinks, cuts, wear, or leaks are found.

11. Check for leaks

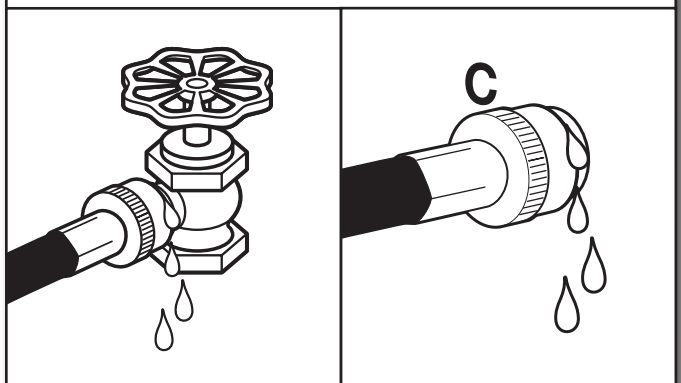

Turn on water faucets to check for leaks. A small amount of water may enter washer. It will drain later.

12. Secure drain hose

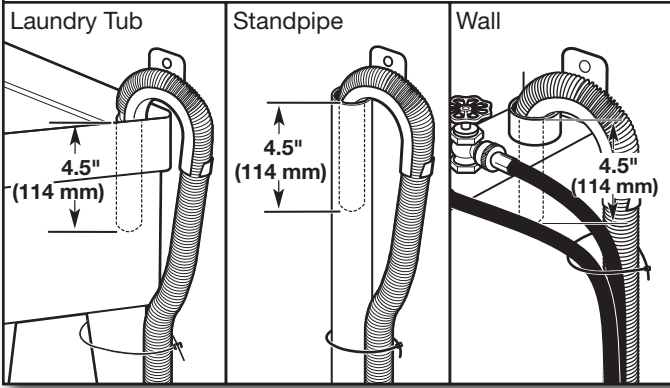

Secure drain hose to laundry tub leg, drain standpipe, or inlet hoses for wall standpipe with cable tie.

LEVEL WASHER

IMPORTANT: Level washer properly to reduce excess noise and vibration.

13. Check levelness of washer

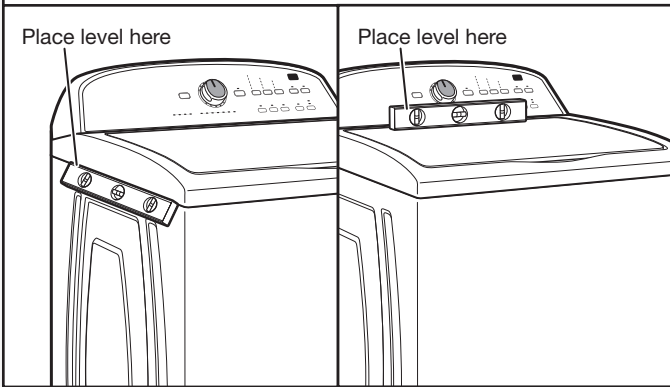

Move the washer to its final location. Place a level on top edges of washer. Use side seam as a guide to check levelness of sides. Check levelness of front using lid, as shown. Rock washer back and forth to make sure all four feet make solid contact with floor. If washer is level, skip to step 15, (on models with metal feet) or step 16 (on models with plastic feet).

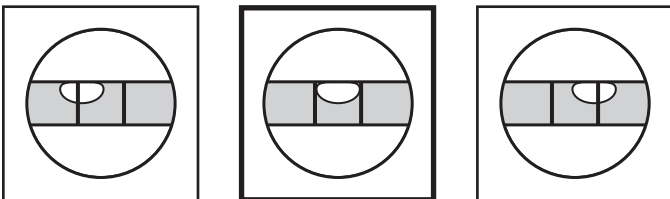

Not Level

LEVEL

Not Level

14. Adjust leveling feet

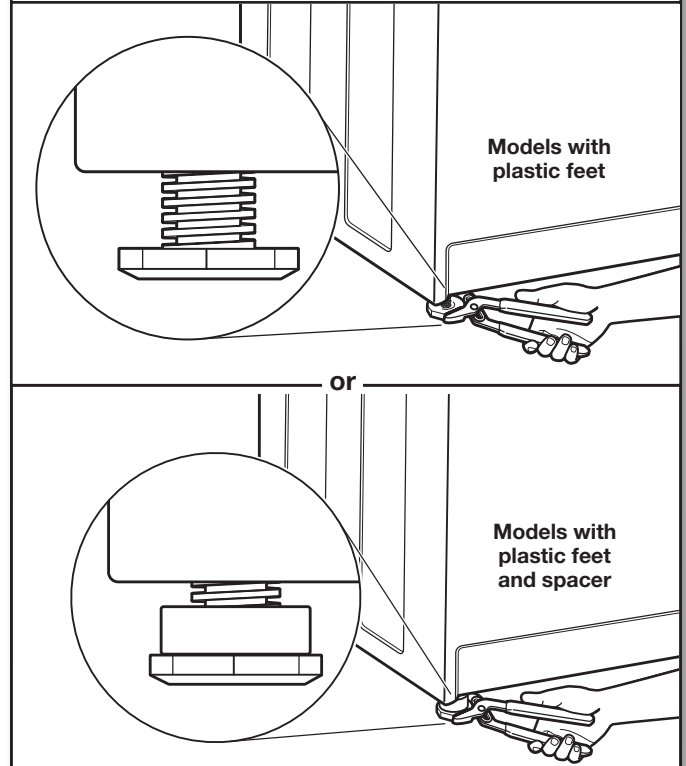

If washer is not level:

Use adjustable pliers to turn the plastic leveling foot counterclockwise to lower the washer or clockwise to raise the washer. On all models, recheck levelness of washer and repeat as needed.

On models with plastic leveling feet with a spacer, use adjustable pliers to turn the foot assembly clockwise in order to raise the washer. To ensure that the foot remains secured to the washer's base, do not adjust the leveling foot more than one full clockwise turn. Recheck levelness of washer and repeat as needed.

IMPORTANT: Do not remove the spacer on the foot if the unit is used with a drip pan or installed on carpet. If additional leveling is needed for washers installed on hard flooring and without the use of a drip pan, the spacer on any foot can be removed.

HELPFUL TIPS:

- You may need to adjust two different feet to level your unit. Ensure each foot remains secured to the washer's base.
- You may want to prop up the front of the washer about 4" (102 mm) with a wood block or similar object that will support the weight of the washer when making the adjustments.

⚠ WARNING



Electrical Shock Hazard

Plug into a grounded 3 prong outlet.

Do not remove ground prong.

Do not use an adapter.

Do not use an extension cord.

Failure to follow these instructions can result in death, fire, or electrical shock.

15. Plug into a grounded 3 prong outlet

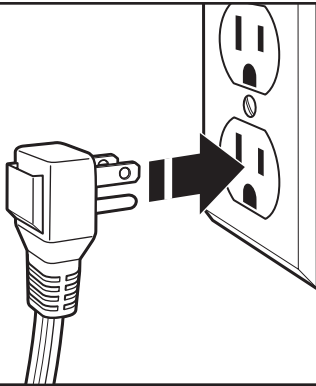

COMPLETE INSTALLATION CHECKLIST

- Check electrical requirements. Be sure you have correct electrical supply and recommended grounding method.
- Check that all parts are now installed. If there is an extra part, go back through steps to see what was skipped.
- Check that you have all of your tools.
- Check that shipping materials were completely removed from washer.
- Check that water faucets are on.
- Check for leaks around faucets and inlet hoses.
- Remove protective film from console and any tape remaining on washer.
- Check that washer is plugged into a grounded 3 prong outlet.
- Dispose of/recycle all packaging materials.
- Read "Washer Care" in your Use and Care Guide.
- To test and clean your washer, measure 1/2 of normal recommended amount of powdered or liquid detergent and pour it into washer basket or detergent dispenser (on some models). Close lid. Select any cycle. Start washer and allow to complete full cycle.