

5KSM7580X, 5KSM7591X,
5KPM5, 5KSM6521X



KitchenAid





English	5
Deutsch	19
Français	33
Italiano	47
Nederlands	61
Español	75
Português	89
Ελληνικά	103
Svenska	117
Norsk	131
Suomi	145
Dansk	159
Íslenska	173
Русский	187
Polski	201
Český	215
Türkçe	229
العربية	1



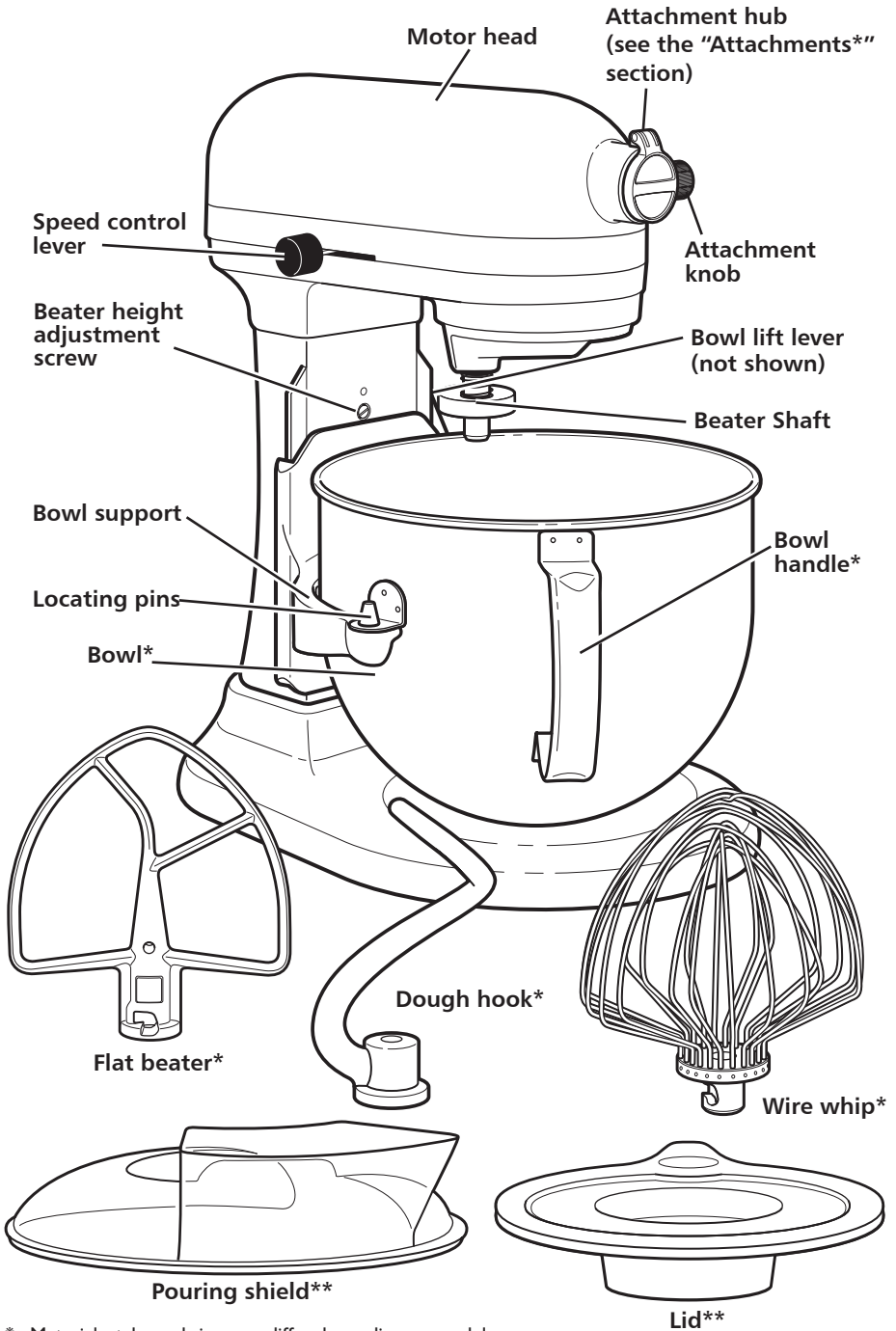

TABLE OF CONTENTS

PARTS AND FEATURES	6
STAND MIXER SAFETY	
Important safeguards	7
Electrical requirements	9
Electrical equipment waste disposal	9
ASSEMBLING THE STAND MIXER	
Attaching the bowl and beaters	10
Adjusting the beater to bowl clearance	11
OPERATING THE STAND MIXER	
Speed control guide - 10 speed Stand Mixers	12
Removing the bowl and beaters	13
TIPS FOR GREAT RESULTS	
Stand Mixer use	13
Mixing time	14
Mixing tips	14
ATTACHMENTS	14
CARE AND CLEANING	15
TROUBLESHOOTING	16
WARRANTY AND SERVICE	
KitchenAid Stand Mixer warranty	17
Customer service	17



PARTS AND FEATURES



* Material, style, and size may differ depending on model.

** Pouring shield included only for models 5KPM5, 5KSM7580X and 5KSM7591X / Lid included only for models 5KPM5 and 5KSM6521X.



Your safety and the safety of others are very important.

We have provided many important safety messages in this manual and on your appliance. Always read and obey all safety messages.



This is the safety alert symbol.

This symbol alerts you to potential hazards that can kill or hurt you and others.

All safety messages will follow the safety alert symbol and either the word "DANGER" or "WARNING." These words mean:



You can be killed or seriously injured if you don't immediately follow instructions.



You can be killed or seriously injured if you don't follow instructions.

All safety messages will tell you what the potential hazard is, tell you how to reduce the chance of injury, and tell you what can happen if the instructions are not followed.

IMPORTANT SAFEGUARDS

When using electrical appliances, basic safety precautions should always be followed, including the following:

1. Read all instructions. Misuse of appliance may result in personal injury.
2. To protect against risk of electrical shock, do not put Stand Mixer in water or other liquid.
3. This appliance is not intended for use by persons (including children) with reduced physical, sensory or mental capabilities, or lack of experience and knowledge, unless they have been given supervision or instruction concerning use of the appliance by a person responsible for their safety.
4. European Union Only: This appliance shall not be used by children. Keep the appliance and its cord out of reach of children.
5. European Union Only: Appliances can be used by persons with reduced physical, sensory or mental capabilities or lack of experience and knowledge if they have been given supervision or instruction concerning use of the appliance in a safe way and understand the hazards involved. Children shall not play with the appliance.



STAND MIXER SAFETY

6. Children should be supervised to ensure they do not play with the appliance.
7. Avoid contacting moving parts. Keep hands, hair, clothing, as well as spatulas and other utensils away from blade during operation to reduce the risk of injury to persons and/or damage to the Stand Mixer.
8. Turn the appliance OFF, then unplug from the outlet when not in use, before assembling or disassembling parts and before cleaning. To unplug, grasp the plug and pull from the outlet. Never pull from the power cord.
9. Do not operate any appliance with a damaged cord or plug or after the appliance malfunctions or has been damaged in any manner. Return appliance to the nearest Authorised Service Centre for examination, repair, or adjustment.
10. If the supply cord is damaged, it must be replaced by the manufacturer, its service agent or similarly qualified persons in order to avoid a hazard.
11. Do not let cord hang over edge of table or counter.
12. Remove the flat beater, wire whip, or dough hook from the Stand Mixer before washing.
13. Do not use the Stand Mixer outdoors.
14. Never leave the appliance unattended while it is in operation.
15. The use of attachments not recommended or sold by KitchenAid may cause fire, electric shock, or injury.
16. To avoid product damage, do not use the mixer bowls in areas of high heat such as an oven, microwave, or on a stovetop.
17. Refer to the “Care and Cleaning” section for instructions on cleaning the surfaces in contact with food.
18. This appliance is intended to be used in household and similar applications such as:
 - staff kitchen areas in shops, offices, or other working environments;
 - farmhouses;
 - by clients in hotels, motels, and other residential type environments;
 - bed and breakfast type environments.

SAVE THESE INSTRUCTIONS



Electrical requirements

WARNING



Electrical Shock Hazard

Plug into an earthed outlet.

Do not remove earth prong.

Do not use an adapter.

Do not use an extension cord.

Failure to follow these instructions can result in death, fire, or electrical shock.

Volts: 220-240 A.C.

Hertz: 50-60 Hz

Wattage: 315 Watts for model 5KPM5
500 Watts for models
5KSM7580X, 5SM7591X,
and 5KSM6521X

NOTE: The power rating for your Stand Mixer is printed on the serial plate, placed under your Stand Mixer.

Do not use an extension cord. If the power supply cord is too short, have a qualified electrician or service technician install an outlet near the appliance.

The wattage rating is determined by using the attachment that draws the greatest load (power). Other recommended attachments may draw significantly less power.

Electrical equipment waste disposal

Disposal of packing material

The packing material is 100% recyclable and is marked with the recycle symbol . The various parts of the packing must therefore be disposed of responsibly and in full compliance with local authority regulations governing waste disposal.

Scrapping the product

- This appliance is marked in compliance with European Directive 2002/96/EC, Waste Electrical and Electronic Equipment (WEEE).

- By ensuring this product is disposed of correctly, you will help prevent potential negative consequences for the environment and human health, which could otherwise be caused by inappropriate waste handling of this product.

- The symbol  on the product or on the accompanying documentation indicates that it should not be treated as domestic waste but must be taken to an appropriate collection centre for the recycling of electrical and electronic equipment.

For more detailed information about treatment, recovery and recycling of this product, please contact your local city office, your household waste disposal service or the shop where you purchased the product.



ASSEMBLING THE STAND MIXER

Attaching the bowl and beaters

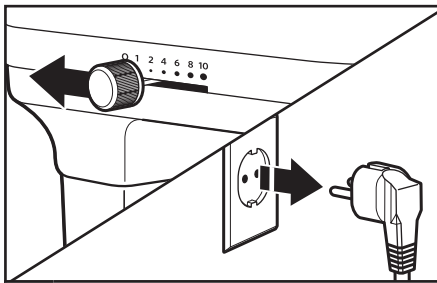

1 Turn speed control to “0” (OFF), and unplug Stand Mixer.

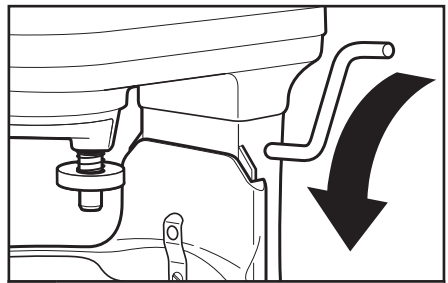

2 Place bowl lift lever into down position.

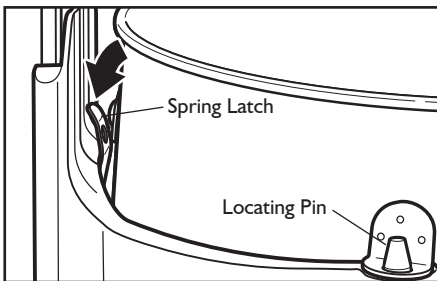

3 Fit bowl supports over locating pins; press down on back of the bowl until bowl pin snaps into the spring latch. If not securely snapped into place, bowl will be unstable and wobble during use.

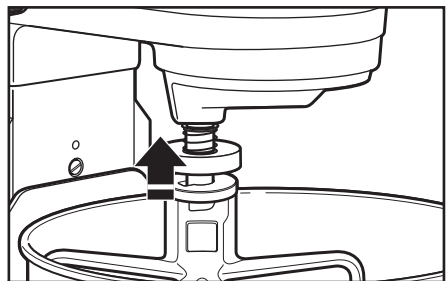

4 Slip a beater (flat, wire whip, or dough hook) onto the beater shaft and press upward as far as possible. Turn beater to the right, hooking it over the pin on the beater shaft.

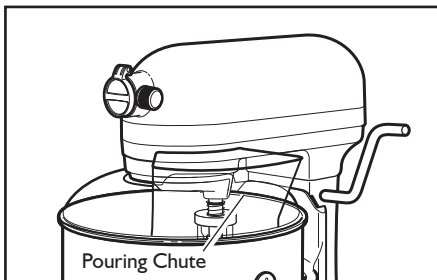

5 If using the pouring shield*, from the front of the Stand Mixer, slide the pouring shield over the bowl until it is centered. The bottom rim of the pouring shield should fit within the bowl.

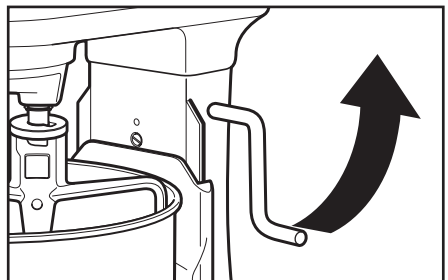

6 Raise the bowl into mixing position by rotating the bowl lift lever counterclockwise to the straight up position. The bowl must always be in the raised position when mixing.

NOTE: Rotate the pouring shield* so the motor head covers the U-shaped gap in the shield. The pouring chute will be just to the right of the attachment hub as you face the Stand Mixer.

* Pouring shield included only for models 5KPM5, 5KSM7580X and 5KSM7591X



ASSEMBLING THE STAND MIXER

Adjusting beater to bowl clearance

Your Stand Mixer is adjusted at the factory so the flat beater just clears the bottom of the bowl. If, for any reason, the flat beater hits the bottom of the bowl or is too far away from the bowl, you can correct the clearance easily.

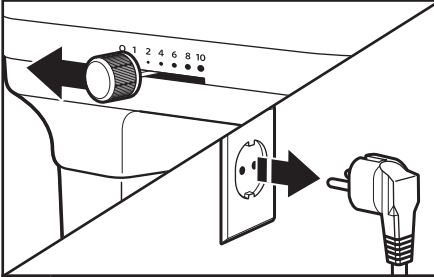

- 1 Turn speed control to "0" (OFF), and unplug Stand Mixer.

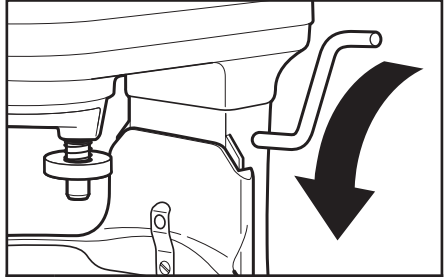

- 2 Lower the bowl to the down position.

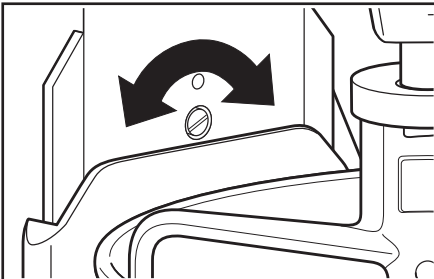

- 3 Turn beater height adjustment screw (A) slightly counterclockwise (left) to raise the flat beater; or turn clockwise (right) to lower the flat beater. Adjust so that the flat beater just clears the surface of the bowl. If you over adjust the screw, the bowl lift lever may not lock in place.

NOTE: When properly adjusted, the flat beater will not strike on the bottom or side of the bowl. If the flat beater or the wire whip is so close that it strikes the bottom of the bowl, the coating may wear off the flat beater (for coated beaters) or wires on the wire whip may wear.

Scraping sides of bowl may be necessary under certain conditions regardless of beater adjustment. The Stand Mixer must be stopped to scrape bowl or damage to Stand Mixer may occur.





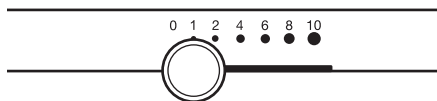

OPERATING THE STAND MIXER

Speed control guide - 10 speed Stand Mixers

All speeds have the Soft Start feature that automatically starts the Stand Mixer at a lower speed to help avoid ingredient splash-out and “flour puff” at start-up, then quickly increases to the selected speed for optimal performance.



Speed	Used for	Accessories	Description
1	Stirring		For slow stirring, combining, mashing, starting all mixing procedures. Use to add flour and dry ingredients to batter, and add liquids to dry ingredients. Do not use Speed 1 to mix or knead yeast doughs.
2	Slow mixing, Kneading		For slow mixing, mashing, faster stirring. Use to mix and knead yeast doughs, heavy batters, and candies; start mashing potatoes or other vegetables; cut shortening into flour; mix thin or splashy batters.
4	Mixing, Beating		For mixing semi-heavy batters, such as cookies. Use to combine sugar and shortening and to add sugar to egg whites for meringues. Medium speed for cake mixes.
6	Beating, Creaming		For medium-fast beating (creaming) or whipping. Use to finish mixing cake, doughnut, and other batters. High speed for cake mixes.
8-10	Fast beating, Whipping, Fast whipping		For whipping cream, egg whites, and boiled frostings. For whipping small amounts of cream, egg whites or for final whipping of mashed potatoes.

NOTE: Use Speed 2 to mix or knead yeast doughs. Use of any other speed creates high potential for Stand Mixer failure. The dough hook efficiently kneads most yeast dough within 4 minutes.



OPERATING THE STAND MIXER

Removing the bowl and beaters

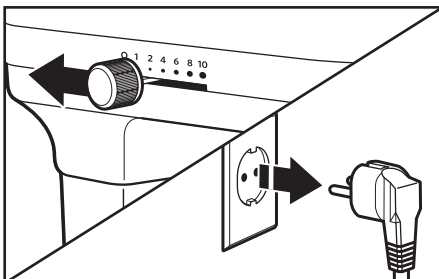

1 Turn speed control to "0" (OFF), and unplug Stand Mixer.

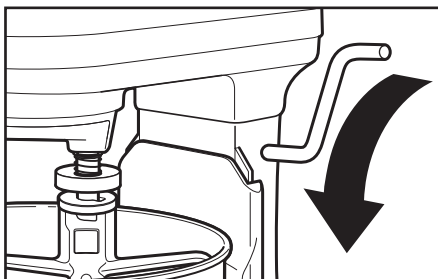

2 Lower the bowl to the down position.

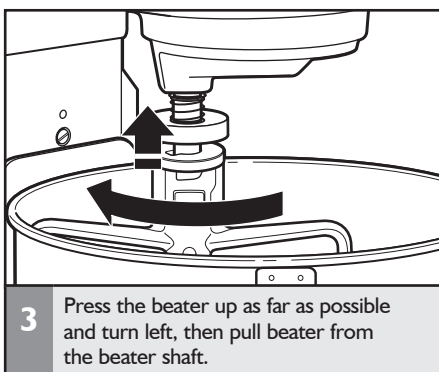

3 Press the beater up as far as possible and turn left, then pull beater from the beater shaft.

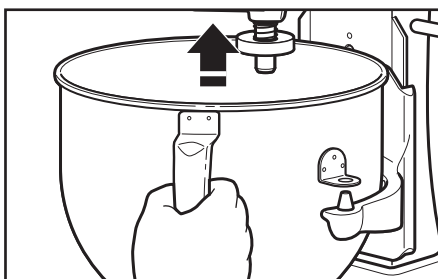

4 Grasp the bowl handle and lift it straight up and off the locating pins.

TIPS FOR GREAT RESULTS

Stand Mixer use

⚠ WARNING

PERSONAL INJURY HAZARD

To avoid personal injury and damage to the beater, do not attempt to scrape bowl while mixer is operating; turn mixer off. Should scraper or other object drop into bowl, turn motor OFF before removing.

The bowl and beater are designed to provide thorough mixing without frequent scraping. Scraping the bowl once or twice during mixing is usually sufficient.

The Stand Mixer may become warm during use. Under heavy loads with extended mixing time periods, you may not be able to comfortably touch the top of the Stand Mixer. This is normal.



TIPS FOR GREAT RESULTS

Mixing time

Your KitchenAid Stand Mixer will mix faster and more thoroughly than most other electric mixers. Therefore, the mixing time in most recipes must be adjusted to avoid overbeating.

To help determine the ideal mixing time, observe the batter or dough and mix only until it has the desired appearance described in your recipe, such as “smooth and creamy.” To select the best mixing speeds, use the “Speed control guide” section.

Mixing tips

Adding Ingredients

Always add ingredients as close to side of bowl as possible, not directly into moving beater. The Pouring Shield can be used to simplify adding ingredients. Use Speed 1 until ingredients have been blended. Then gradually increase to desired speed.

Adding Nuts, Raisins, or Candied Fruits

Follow individual recipes for guidelines on including these ingredients. In general, solid materials should be folded in the last few seconds of mixing on Speed 1. The batter should be thick enough to keep the fruit or nuts from sinking to the bottom of the pan during baking. Sticky fruits should be dusted with flour for better distribution in the batter.

Liquid Mixtures

Mixtures containing large amounts of liquid ingredients should be mixed at lower speeds to avoid splashing. Increase speed only after mixture has thickened.

NOTE: If ingredients in very bottom of bowl are not thoroughly mixed, then the beater is not far enough into the bowl. See the “Setting up your Stand Mixer” section.

ATTACHMENTS

KitchenAid optional attachments are designed to assure long life. The attachment power shaft and attachment hub socket are of a square design, to eliminate any possibility of slipping during the transmission of power to the attachment. The hub and shaft housings are tapered to assure a snug fit, even after prolonged use and wear. KitchenAid attachments require no extra power unit to operate them; the power unit is built-in.

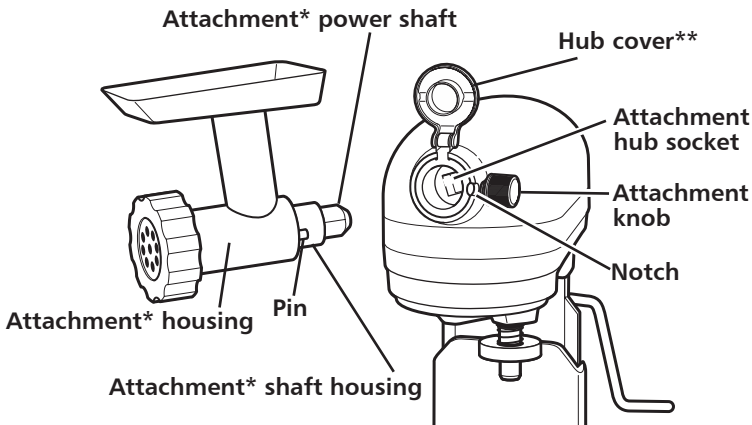

* Optional attachment, not part of the mixer.

** Style may vary depending on model.



⚠️ WARNING

ELECTRICAL SHOCK HAZARD
ALWAYS BE SURE TO UNPLUG MIXER BEFORE CLEANING TO AVOID POSSIBLE ELECTRICAL SHOCK.

Wipe mixer with a damp cloth.
DO NOT IMMERSE IN WATER.
 Wipe off beater shaft frequently, removing any residue that may accumulate.

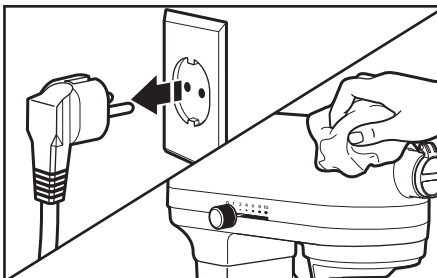

1 Always be sure to unplug Stand Mixer before cleaning. Wipe Stand Mixer with a soft, damp cloth. Do not use household/commercial cleaners. Wipe off beater shaft frequently, removing any residue that may accumulate. Do not immerse in water.

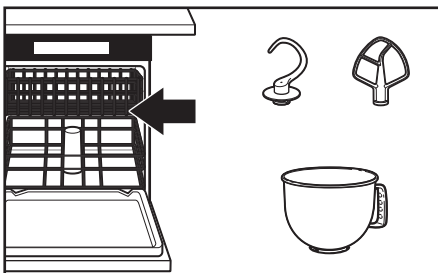

2 The bowl, flat beater, and dough hook may be washed in a dishwasher. Or, clean them thoroughly in hot sudsy water and rinse completely before drying. Do not store beaters on shaft.

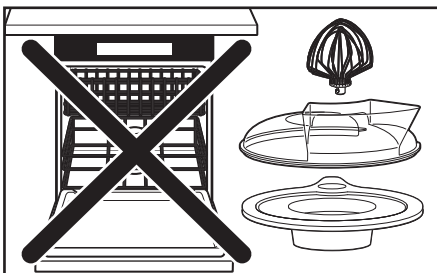

3 **IMPORTANT:** The wire whip, pouring shield, and lid are **not** dishwasher safe. Clean thoroughly in hot sudsy water and rinse completely before drying. Do not store wire whip on shaft.

** Pouring shield included only for models 5KPM5, 5KSM7580X and 5KSM7591X / Lid included only for models 5KPM5 and 5KSM6521X.



⚠️ WARNING



Electrical Shock Hazard

Unplug before servicing.

Failure to do so can result in death or electrical shock.

Please read the following before calling your service center.

1. The Stand Mixer may warm up during use. Under heavy loads with extended mixing time periods, you may not be able to comfortably touch the top of the unit. This is normal.
 2. The Stand Mixer may emit a pungent odor, especially when new. This is common with electric motors.
 3. If the Flat Beater hits the Bowl, stop the Stand Mixer. See the “Setting Up Your Stand Mixer” section.
- If your Stand Mixer should malfunction or fail to operate, please check the following:**
- Is the Stand Mixer plugged in?
 - Is the fuse in the circuit to the Stand Mixer in working order? If you have a circuit breaker box, be sure the circuit is closed.
 - Turn off the Stand Mixer for 10-15 seconds, then turn it back on. If the mixer still does not start, allow it to cool for 30 minutes before turning it back on.
 - If the problem is not due to one of the above items, see the “Customer service” section.



WARRANTY AND SERVICE

KitchenAid Stand Mixer warranty

Length of Warranty:	KitchenAid Will Pay For:	KitchenAid Will Not Pay For:
Europe, Middle East and Africa: For models 5KPM5, and 5KSM7591X: Two years full warranty from date of purchase. For models 5KSM7580X, 5KSM6521X: Five years full warranty from date of purchase.	The replacement parts and repair labor costs to correct defects in materials or workmanship. Service must be provided by an Authorized KitchenAid Service Center.	A. Repairs when Stand Mixer is used for operations other than normal household food preparation. B. Damage resulting from accident, alterations, misuse, abuse, or installation/operation not in accordance with local electrical codes.

KITCHENAID DOES NOT ASSUME ANY RESPONSIBILITY FOR INDIRECT DAMAGES.

Customer service

In U.K. and Ireland:

For any questions, or to find the nearest KitchenAid Authorised Service Centre, please find our contact details below.

NOTE: All service should be handled locally by an Authorised KitchenAid Service Centre.

General hotline number:  00800 3810 4026

In other countries:

For all product related questions and after sales matters, please contact your dealer to obtain the name of the nearest Authorised KitchenAid Service/Customer Centre.

For more information, visit our website at:

www.KitchenAid.co.uk

www.KitchenAid.eu

©2019 All rights reserved.
Specifications subject to change without notice.



KitchenAid

©2019 All rights reserved.
Specifications subject to change without notice.

W11356007A

03/19

