



KitchenAid

6.9 L PROFESSIONAL BOWL-LIFT STAND MIXER

Original Instructions

**KÜCHENMASCHINE MIT SCHÜSSELHEBER UND 6,9 L SCHÜSSEL
FÜR DEN GEWERBLICHEN EINSATZ**

Originalanleitungen

ROBOT SUR SOCLE PROFESSIONNEL À BOL RELEVABLE DE 6,9 L

Instructions d'origine

ROBOT DA CUCINA PROFESSIONALE CON SOLLEVAMENTO CIOTOLA DA 6,9 L

Istruzioni originali

6,9 L PROFESSIONELE MIXER/KEUKENROBOT MET IN DE HOOGTE VERSTELBARE KOM

Originele instructies

BATIDORA PROFESIONAL DE PIE CON BOL ELEVABLE DE 6,9 L

Instrucciones originales

BATEDEIRA PROFISSIONAL COM SUPORTE PARA TAÇA DE 6,9 L

Intruções originais

ΕΠΑΓΓΕΛΜΑΤΙΚΟ ΜΙΞΕΡ ΜΕ ΒΑΣΗ ΚΑΙ ΥΠΕΡΥΨΩΜΕΝΟ ΜΠΟΛ 6,9 L

Αρχικές οδηγίες

6,9 L PROFESSIONELL KÖKSMASKIN MED SKÅL PÅ HÄVARM

Originalinstruktioner

6,9 L BOLLELØFTENDE KJØKKENMASKIN

Originale instruksjoner

6,9 L AMMATTIKÄYTTÖÖN TARKOITETTU YLEISKONE

Alkuperäiset ohjeet

6,9 L PROFESSIONEL KØKKENMASKINE MED SKÅLLØFT

Originale Instruktioner

6,9 L BORDHRÆRIVÉL MED LYFTANLEGRI SKÁL FYRIR FAGFÓLK

Upphaflegar leiðbeiningar

ПРОФЕССИОНАЛЬНЫЙ МИКСЕР СО СЪЕМНОЙ ЧАШЕЙ 6,9 Л

Оригинальные инструкции

PROFESJONALNY MIKSER STOJĄCY Z PODNOSZONĄ DZIEŻĄ 6,9 L

Oryginalna instrukcja

PROFESIONÁLNÍ KUCHYŇSKÝ ROBOT SE ZVEDACÍ MÍSOU O OBJEMU 6.9 L

Originální pokyny

PROFESIONÁLNY KUCHYNSKÝ ROBOT SO ZDVÍHACOU MISOU O OBJEME 6,9 L

Originálne pokyny

MIXER PROFESIONAL CU SOCLU ŞI BOL DE 6,9 L

Instrucţiuni originale

ПРОФЕСИОНАЛЕН КУХНЕНСКИ РОБОТ С ПОВДИГАЩА СЕ КУПА С ВМЕСТИМОСТ 6,9 L

Оригинални инструкции

خلاط ثابت بتصميم احترافي مع إمكانية رفع الوعاء سعة ٦,٩ لترات
الإرشادات الأصلية

Model 5KSM7990*





English

Table of Contents

STAND MIXER SAFETY

- Important Safeguards 3
- Electrical Requirements 5
- Electrical Waste Disposal 5

PARTS AND FEATURES 6

SETTING UP YOUR STAND MIXER

- Assembling Your Stand Mixer 7
- Adjusting Your Beater to Bowl Clearance..... 9

USING YOUR STAND MIXER

- Using Your KitchenAid Accessories 9
- Speed Control Guide - 10 Speed Stand Mixers 10

CARE AND CLEANING..... 11

TIPS FOR GREAT RESULTS

- Planetary Mixing Action 12
- Mixing Time 12
- Mixer Use..... 12
- Mixing Tips..... 12

SERVICE AND WARRANTY

- When You Need Service 13
- KitchenAid Commercial Bowl-Lift Stand Mixer Warranty 13
- Service Centers 14
- Customer Service 14



STAND MIXER SAFETY

Your safety and the safety of others are very important.

We have provided many important safety messages in this manual and on your appliance. Always read and obey all safety messages.



This is the safety alert symbol.

This symbol alerts you to potential hazards that can kill or hurt you and others.

All safety messages will follow the safety alert symbol and either the word "DANGER" or "WARNING." These words mean:



You can be killed or seriously injured if you don't immediately follow instructions.



You can be killed or seriously injured if you don't follow instructions.

All safety messages will tell you what the potential hazard is, tell you how to reduce the chance of injury, and tell you what can happen if the instructions are not followed.

IMPORTANT SAFEGUARDS

When using electrical appliances, basic safety precautions should always be followed, including the following:

1. Read all instructions. Misuse of appliance may result in personal injury.
2. To protect against risk of electrical shock, do not put Stand Mixer in water or other liquid.
3. Close supervision is necessary when any appliance is used by or near children.
4. Turn the appliance OFF, then unplug from the outlet when not in use, before assembling or disassembling parts and before cleaning. To unplug, grasp the plug and pull from the outlet. Never pull from the power cord.
5. Avoid contacting moving parts. Keep hands, hair, clothing, as well as spatulas and other utensils away from beater during operation to reduce the risk of injury to persons and/or damage to the Stand Mixer.
6. Do not operate Stand Mixer with a damaged cord or plug or after the Stand Mixer malfunctions, or is dropped or damaged in any manner.
7. The use of attachments not recommended or sold by KitchenAid may cause fire, electrical shock or injury.
8. Do not use the Stand Mixer outdoors.
9. Do not let the cord hang over edge of table or counter.
10. Remove flat beater, wire whip or dough hook from Stand Mixer before washing.



STAND MIXER SAFETY

English

11. European Union Only: Appliances can be used by persons with reduced physical, sensory or mental capabilities or lack of experience and knowledge if they have been given supervision or instruction concerning use of the appliance in a safe way and understand the hazards involved. Children shall not play with the appliance.
12. European Union Only: This appliance shall not be used by children. Keep the appliance and its cord out of reach of children.
13. If the supply cord is damaged, it must be replaced by the manufacturer, its service agent, or similarly qualified persons in order to avoid a hazard.
14. Refer to the “Care and Cleaning” section for instructions on cleaning the surfaces in contact with food.

SAVE THESE INSTRUCTIONS

THIS PRODUCT IS DESIGNED FOR COMMERCIAL USE





STAND MIXER SAFETY

Electrical Requirements

⚠ WARNING



Electrical Shock Hazard

Plug into a grounded outlet.

Do not remove ground prong.

Do not use an adapter.

Do not use an extension cord.

Failure to follow these instructions can result in death, fire, or electrical shock.

Volts: 220-240 A.C.

Hertz: 50-60 Hz

Power: 325 W, Recommended operating time: 1-30 minutes with a duty cycle of 10-min. ON/ 15 min. OFF.

Do not use an extension cord. If the power supply cord is too short, have a qualified electrician or serviceman install an outlet near the appliance.

The wattage rating is determined by using the attachment that draws the greatest load (power). Other recommended attachments may draw significantly less power.

This product is supplied with a Y type power cord. If the power cord is damaged, it must be replaced by the manufacturer or a service agent in order to avoid a hazard.

The acoustic pressure level measured in conformity with the prEN 454-test code is less than 70 dBA.

A * in the model number indicates additional characters that designate machine color and engineering digits for the actual model (eg. 5KSM7990*).

Electrical Waste Disposal

This appliance is marked according to the European directive 2012/19/EU on Waste Electrical and Electronic Equipment (WEEE).

By ensuring this product is disposed of correctly, you will help avoid potential negative consequences for the environment and human health, which could otherwise be caused by inappropriate waste handling of this product.

The symbol  on the product, or on the documents accompanying the product, indicates that this appliance

may not be treated as household waste. Instead it shall be handed over to the applicable collection point for the recycling of electrical and electronic equipment.

Disposal must be carried out in accordance with local environmental regulations for waste disposal.

For more detailed information about treatment, recovery and recycling of this product, please contact your local city office, your household waste disposal service or the shop where you purchased the product.



PARTS AND FEATURES

English

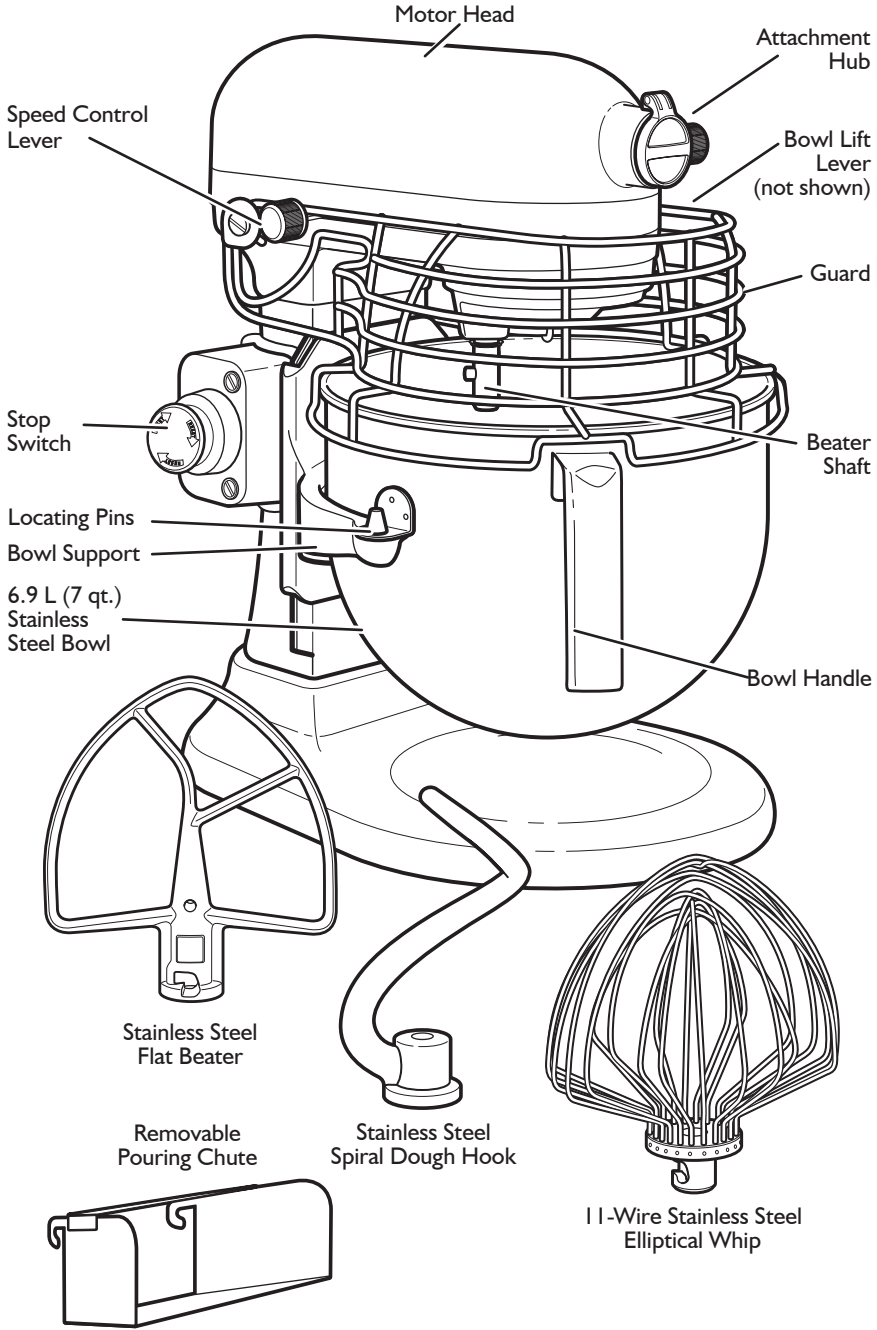



SETTING UP YOUR STAND MIXER

Assembling Your Stand Mixer

To Attach Bowl

1. Turn Speed Control Lever to "0" (OFF).
2. Unplug Stand Mixer or disconnect power.
3. Raise Guard.
4. Place Bowl Lift Lever in down position.
5. Fit Bowl Supports over Locating Pins.
6. Press down on back of bowl until bowl pin snaps into spring latch.

NOTE: If bowl is not securely snapped into place, the bowl will be unstable and wobble during use.

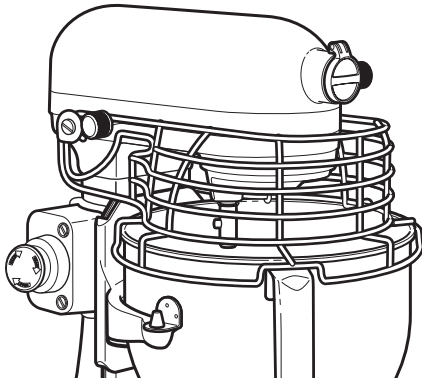

7. Lower Guard.
8. Raise bowl before mixing.

To Remove Bowl

1. Turn Speed Control Lever to "0" (OFF).
2. Unplug Stand Mixer or disconnect power.
3. Raise Guard.

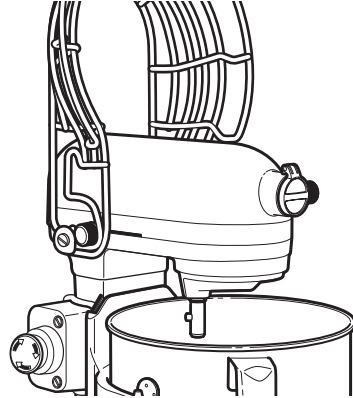

4. Place Bowl Lift Lever in down position.
5. Remove Flat Beater, Wire Whip, or Dough Hook.
6. Grasp Bowl Handle and lift straight up and off Locating Pins.

To Raise Bowl

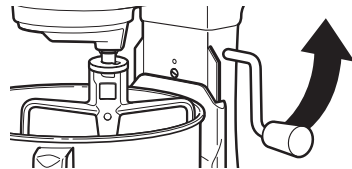

1. Rotate lever counterclockwise to straight-up position.
2. Bowl must always be in raised, locked position when mixing.



SETTING UP YOUR STAND MIXER

English

INSTALLATION: The stand mixer shall be installed on a level and stable surface such as a countertop or work table.

To Lower Bowl

1. Rotate lever back and down.

To Attach Flat Beater, Wire Whip, or Dough Hook

1. Turn Speed Control Lever to "0" (OFF).
2. Unplug Stand Mixer or disconnect power.
3. Raise Guard.
4. Slip Flat Beater on Beater Shaft and press upward as far as possible.
5. Turn beater to right, hooking beater over the pin on shaft.

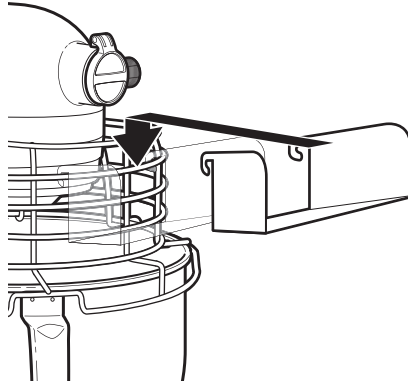
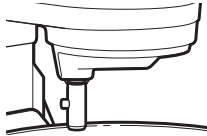

Removable Pouring Chute

The Removable Pouring Chute is easily attached to the front of the Guard as shown in the illustration above. It provides a convenient way to add ingredients to the Stand Mixer bowl.

To Remove Flat Beater, Wire Whip, or Dough Hook

1. Turn Speed Control Lever to "0" (OFF).
2. Unplug Stand Mixer or disconnect power.
3. Raise Guard.
4. Press beater upward as far as possible and turn left.
5. Pull beater from Beater Shaft.

Auto-Reset Motor Protection

If the Stand Mixer stops due to overload, slide the Speed Control Lever to "0" (OFF) and unplug the Stand Mixer. After a few minutes, the Stand Mixer will automatically reset. Plug the Stand Mixer back in and slide the Speed Control Lever to the desired speed and continue mixing. If the Stand Mixer does not restart, unplug the Stand Mixer for a longer period of time to allow it to cool, then plug back in and restart the Stand Mixer. If the Stand Mixer does not restart, see "When You Need Service".

Speed Control Lever

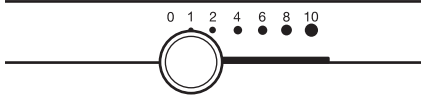

The Soft Start feature minimizes splash-out by starting the mixer slowly before increasing to the selected speed. To further reduce the potential for splash-out, always begin mixing using Speed 1, then gradually move to higher speeds as needed. See "Speed Control Guide".

Stop Switch

If you need to stop the Stand Mixer immediately during use, press the Stop Switch. To resume operation, reset the Speed Control Lever to "0" (OFF), and pull out the Stop Switch. Then, your Stand Mixer is ready to be used normally again.





SETTING UP YOUR STAND MIXER

Adjusting Your Beater to Bowl Clearance

Your Stand Mixer is adjusted at the factory so the Flat Beater just clears the bottom of the bowl. If, for any reason, the Flat Beater hits the bottom of the bowl or is too far away from the bowl, you can correct the clearance easily.

1. Turn speed control to "0" (OFF).
2. Unplug Stand Mixer or disconnect power.
3. Raise Guard.
4. Lower the bowl to the down position.
5. Turn Beater Height Adjustment Screw slightly counter clockwise (left) to raise Flat Beater or clockwise (right) to lower Flat Beater.
6. Make adjustment with Flat Beater, so it just clears surface of the bowl. If you over adjust the screw, the Bowl Lift Lever may not lock into place.

NOTE: When properly adjusted, the Flat Beater will not strike the bottom or side of the bowl. If the Flat Beater or the Stainless Steel Whip is so close that it strikes the bottom of the bowl, coating may wear off the Flat Beater (for coated beaters) or wires on Stainless Steel Whip may wear.

Scraping sides of bowl may be necessary under certain conditions regardless of beater adjustment. The Stand Mixer must be stopped to scrape bowl or damage to mixer may occur.

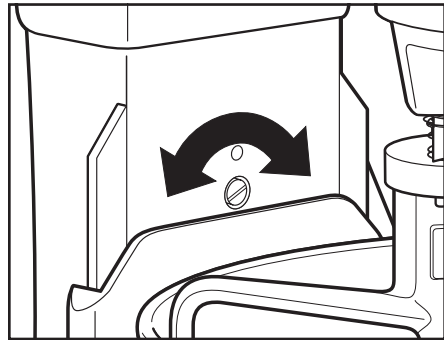

USING YOUR STAND MIXER

Using Your KitchenAid Accessories

Flat Beater for normal to heavy mixtures

(Recommended operating time is 1-10 minutes, depending upon recipe):

cakes	biscuits
creamed frostings	quick breads
candies	meat loaf
cookies	mashed potatoes
pie pastry	

Wire Whip for mixtures that need air incorporated

(Recommended operating time is 1-30 minutes, depending upon recipe):

eggs	sponge cakes
egg whites	angel food cakes
heavy cream	mayonnaise
boiled frostings	some candies

Dough Hook for mixing and kneading yeast doughs

(Recommended operating time is 1-10 minutes, depending upon recipe):

bread	coffee cakes
rolls	buns









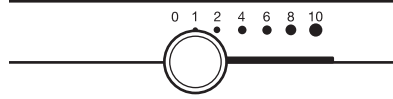

USING YOUR STAND MIXER

Speed Control Guide - 10 Speed Stand Mixers

English

All speeds have the Soft Start feature that automatically starts the Stand Mixer at a lower speed to help avoid ingredient splash-out and “flour puff” at start-up, then quickly increases to the selected speed for optimal performance.



Speed	Used for	Accessories	Description
1	Stirring		For slow stirring, combining, mashing, starting all mixing procedures. Use to add flour and dry ingredients to batter, and add liquids to dry ingredients. Do not use Speed 1 to mix or knead yeast doughs.
2	Slow Mixing, Kneading	 	For slow mixing, mashing, faster stirring. Use to mix and knead yeast doughs, heavy batters, and candies; start mashing potatoes or other vegetables; cut shortening into flour; mix thin or splashy batters.
4	Mixing, Beating	 	For mixing semi-heavy batters, such as cookies. Use to combine sugar and shortening and to add sugar to egg whites for meringues. Medium speed for cake mixes.
6	Beating, Creaming	 	For medium-fast beating (creaming) or whipping. Use to finish mixing cake, doughnut, and other batters. High speed for cake mixes.
8-10	Fast Beating, Whipping, Fast Whipping		For whipping cream, egg whites, and boiled frostings. For whipping small amounts of cream, egg whites or for final whipping of mashed potatoes.

NOTE: Use Speed 2 to mix or knead yeast doughs. Use of any other speed creates high potential for Stand Mixer failure. The PowerKnead Spiral Dough Hook efficiently kneads most yeast dough within 4 minutes.

Capacity Chart

	6.9 L Bowl
Flour	2 to 2.2 kg
Bread	8 breads of 450 g
Cookies / Biscuits	160 pieces
Mashed Potatoes	3.6 kg





CARE AND CLEANING

Stainless Steel Bowl, Flat Beater, Stainless Steel Whip, Spiral Dough Hook, and Pouring Chute may be washed in an automatic dishwasher. Do not use cleaners with a pH lower than 5. Or, clean them thoroughly in hot sudsy water and rinse completely before drying. Do not store beaters on shaft. The Stand Mixer is not to be cleaned with a water jet or spray hose.

! WARNING

ELECTRICAL SHOCK HAZARD
ALWAYS BE SURE TO UNPLUG MIXER BEFORE CLEANING TO AVOID POSSIBLE ELECTRICAL SHOCK.

Wipe mixer with a damp cloth. DO NOT IMMERSE IN WATER. Wipe off beater shaft frequently, removing any residue that may accumulate.

English



TIPS FOR GREAT RESULTS

English

Planetary Mixing Action

During operation, the Flat Beater moves around the stationary bowl, at the same time turning in the opposite direction on its own axis.

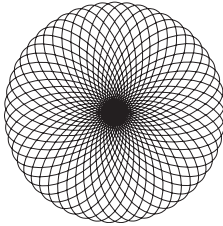

The diagram shows the complete coverage of the bowl made by the path of the Beater.

The 5KSM7990 is rated 500 Watts and uses a Direct Current motor. It is a quiet and highly efficient motor, combined with a direct drive transmission system : this enables to drive 1.3 Horse Power at peak power (output motor power), enabling fast and outstanding mixing results even with heavy dough.

Mixing Time

Your KitchenAid Mixer will mix faster and more thoroughly than most other electric mixers. Therefore, the mixing time in most recipes must be adjusted to avoid overbeating.

To help determine the ideal mixing time, observe the batter or dough and mix only until it has the desired appearance described in your recipe, such as “smooth and creamy.” To select the best mixing speeds, use the “Speed Control Guide” section.

Mixer Use

⚠ WARNING

PERSONAL INJURY HAZARD

To avoid personal injury and damage to the beater, do not attempt to scrape bowl while mixer is operating; turn mixer off. Should scraper or other object drop into bowl, turn motor OFF before removing.

The bowl and beater are designed to provide thorough mixing without frequent scraping. Scraping the bowl once or twice during mixing is usually sufficient.

The Stand Mixer may become warm during use. Under heavy loads with extended mixing time periods, you may not be able to comfortably touch the top of the Stand Mixer. This is normal.

Mixing Tips

Adding Ingredients

Always add ingredients as close to side of bowl as possible, not directly into moving beater. The Pouring Chute can be used to simplify adding ingredients. Use Speed 1 until ingredients have been blended. Then gradually increase to desired speed.

Adding Nuts, Raisins, or Candied Fruits

Follow individual recipes for guidelines on including these ingredients. In general, solid materials should be folded in the last few seconds of mixing on Speed 1. The batter should be thick enough to keep the fruit or nuts from sinking to the bottom of the pan during baking. Sticky fruits should be dusted with flour for better distribution in the batter.

Liquid Mixtures

Mixtures containing large amounts of liquid ingredients should be mixed at lower speeds to avoid splashing. Increase speed only after mixture has thickened.

NOTE: If ingredients in very bottom of bowl are not thoroughly mixed, then the beater is not far enough into the bowl. See the “Setting Up Your Stand Mixer” section.

SERVICE AND WARRANTY

When You Need Service

⚠ WARNING



Electrical Shock Hazard
Unplug before servicing.
Failure to do so can result in death or electrical shock.

Please read the following before calling your service center.

1. The Stand Mixer may warm up during use. Under heavy loads with extended mixing time periods, you may not be able to comfortably touch the top of the unit. This is normal.

2. The Stand Mixer may emit a pungent odor, especially when new. This is common with electric motors.
3. If the Flat Beater hits the Bowl, stop the Stand Mixer. See the “Setting Up Your Stand Mixer” section.

If your Stand Mixer should malfunction or fail to operate, please check the following:

- Is the Stand Mixer plugged in?
- Is the fuse in the circuit to the Stand Mixer in working order? If you have a circuit breaker box, be sure the circuit is closed.
- Is the Stop Switch pulled out?
- Turn off the Stand Mixer for 10-15 seconds, then turn it back on. If the mixer still does not start, allow it to cool for 30 minutes before turning it back on.
- If the problem is not due to one of the above items, see the “Service Centers” section.

English

KitchenAid Commercial Bowl-Lift Stand Mixer Warranty

Length of Warranty:	KitchenAid Will Pay For:	KitchenAid Will Not Pay For:
<p>Europe, Australia and New Zealand:</p> <p>For the Commercial Mixer 5KSM7990: One Year Full Warranty from date of purchase.</p>	<p>The replacement parts and repair labor costs to correct defects in materials or workmanship. Service must be provided by an Authorized KitchenAid Service Center.</p>	<p>Damage resulting from accident, alterations, misuse, abuse, or installation/operation not in accordance with local electrical codes.</p>

KITCHENAID DOES NOT ASSUME ANY RESPONSIBILITY FOR INDIRECT DAMAGES.



SERVICE AND WARRANTY

English

Service Centers

All service should be handled locally by an Authorized KitchenAid Service Center. Contact the dealer from whom the unit was purchased to obtain the name of the nearest Authorized KitchenAid Service Center.

In the U.K.:

Call: 0845 6011 287

In Ireland:

M.X. ELECTRIC
Service Department
25 Alymer Crescent
Kilcock, Co. KILDARE

Call: 87 2581574

Fax: 1 628 4368

In Australia:

Call: 1800 990 990

In New Zealand:

Call: 0800 881 200

Customer Service

In U.K. & Ireland:

Toll-free number 0800 988 1266
(Calls from mobile phones are charged standard network rate)

Address:

KitchenAid Europa, Inc.
PO BOX 19
B-2018 ANTWERP 11
BELGIUM

For Southern Ireland:

Toll-free number +44 (0) 20 8616 5148

www.KitchenAid.co.uk
www.KitchenAid.eu



Technology Center
303 Upton Drive, St. Joseph, MI 49085-1175

English

**EU – DECLARATION OF CONFORMITY
CE-DECLARATION DE CONFORMITE**

We: WHIRLPOOL CORPORATION, 303 UPTON DR., ST. JOSEPH, MI 49085, USA
Representing: WHIRLPOOL EUROPE S.r.l I-21025 COMERIO

Declare under sole responsibility that the product:

KitchenAid™ Stand Mixers: Model 5KSM79XX+

Where:

XX = up to 2 alphanumeric characters, which represents the features, distributor code and/or color

+ = May or may not be followed by five or more digit suffix codes to indicate change in aesthetics

to which this declaration relates, is in conformity with the following standard(s) or other normative document(s):

- IEC 60335-1: Ed.5: 2010**
- IEC 60335-2-64: Edition 3.1 2008-03**
- EN 55014-1:2006 + A1:2009**
- EN 55014-2:1997 + A1:2001 + A2:2008**
- EN 61000-3-2:2006 + A1:2009 + A2:2009**
- EN 61000-3-3:2008**
- EN 62233:2008**

The model listed conforms to the provisions of Directive (s):

- 2004/108/EC ELECTROMAGNETIC COMPATABILITY DIRECTIVE**
- 2006/95/EC LOW VOLTAGE DIRECTIVE**
- 2006/42/EC MACHINERY DIRECTIVE**
- 10/2011/EU PLASTIC MATERIALS INTENDED TO CONTACT FOOD**
- 1935/2004/EC MATERIALS INTENDED TO CONTACT FOOD**

Place and Date:
Saint Joseph, MI, USA
30 January, 2012

Represented by:

Mark Dahmer
Engineering Director
KitchenAid Portable Appliances Division



KitchenAid

©2019 All rights reserved.
Specifications subject to change without notice.

W11357725A

03/19

