

USE AND CARE GUIDE AND INSTALLATION INSTRUCTIONS

UNDER COUNTER REFRIGERATOR

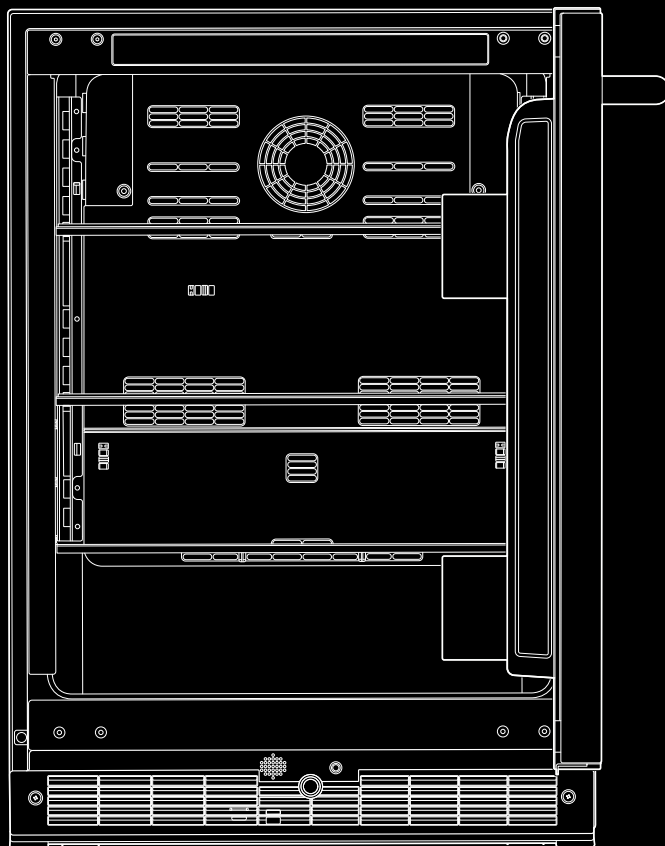

For questions about features, operation/performance, parts, accessories, or service, call:
1-800-JENNAIR (1-800-536-6247) or visit our website at **www.jennair.com**.

In Canada, call: **1-800-JENNAIR (1-800-536-6247)**, or visit our website at **www.jennair.ca**.



TABLE OF CONTENTS

INTRODUCTION

| | |
|---|---|
| Safety..... | 3 |
| Proper Disposal of Your Old Refrigerator..... | 4 |
| Features..... | 4 |

INSTALLATION REQUIREMENTS

| | |
|------------------------------|---|
| Tools and Parts..... | 5 |
| Location Requirements..... | 5 |
| Product Dimensions..... | 6 |
| Custom Overlay Panel..... | 6 |
| Handle (Optional)..... | 7 |
| Electrical Requirements..... | 8 |

INSTALLATION INSTRUCTIONS

| | |
|--|----|
| Unpack the Refrigerator..... | 8 |
| Custom Overlay Panel Installation..... | 9 |
| Installation and Door Closing..... | 10 |

USING REFRIGERATOR

| | |
|---------------------------|----|
| Controls..... | 11 |
| Normal Sounds..... | 12 |
| Refrigerator Shelves..... | 12 |
| Door Bins..... | 13 |
| Lights..... | 13 |

CARE AND CLEANING

| | |
|---------------------------|----|
| Cleaning..... | 13 |
| Removing Base Grille..... | 13 |
| Vacation Care..... | 14 |
| Moving Care..... | 14 |

TROUBLESHOOTING

| | |
|-------------------------------|----|
| Operation..... | 14 |
| Temperature and Moisture..... | 14 |
| Door..... | 15 |

ASSISTANCE

| | |
|-------------------|----|
| In the U.S.A..... | 15 |
| In Canada..... | 15 |
| Warranty..... | 16 |

INTRODUCTION

SAFETY

Your safety and the safety of others are very important.

We have provided many important safety messages in this manual and on your appliance. Always read and obey all safety messages.



This is the safety alert symbol.

This symbol alerts you to potential hazards that can kill or hurt you and others.

All safety messages will follow the safety alert symbol and either the word "DANGER" or "WARNING."

These words mean:

⚠ DANGER

You can be killed or seriously injured if you don't immediately follow instructions.

⚠ WARNING

You can be killed or seriously injured if you don't follow instructions.

All safety messages will tell you what the potential hazard is, tell you how to reduce the chance of injury, and tell you what can happen if the instructions are not followed.

IMPORTANT SAFETY INSTRUCTIONS

WARNING: To reduce the risk of fire, electric shock, or injury when using your refrigerator, follow these basic precautions:

- Plug into a grounded 3 prong outlet.
- Do not remove ground prong.
- Do not use an adapter.
- Do not use an extension cord.
- Disconnect power before servicing.
- Replace all parts and panels before operating.
- Remove doors from your old refrigerator.
- Use non flammable cleaner.
- Do not store or use petrol, flammable liquids or gas in the vicinity of this or other electrical appliances. The fumes can cause fires or explosions.
- Do not store explosive substances such as aerosol cans with a flammable propellant in this refrigerator.
- Do not use or place electrical devices inside the refrigerator compartments if they are not of the type expressly authorized by the manufacture.
- Use two or more people to move and install refrigerator.
- This appliance is not intended for use by persons (including children) with reduced physical, sensory or mental capabilities, or lack of experience and knowledge, unless they have been given supervision or instruction concerning use of the appliance by a person responsible for their safety.
- Children should be supervised to ensure that they do not play with the appliance.
- To avoid the risk of children becoming trapped and suffocating, do not allow them to play or hide inside the refrigerator.
- If the power supply cord is damaged, it must be replaced by the manufacturer or its service agent or a similarly qualified person.
- Keep ventilation openings, in the appliance enclosure or in the built-in structure, clear of obstruction.
- Do not use mechanical devices or other means to accelerate the defrosting process, other than those recommended by the manufacturer.
- Do not damage the refrigerant circuit.

SAVE THESE INSTRUCTIONS

PROPER DISPOSAL OF YOUR OLD REFRIGERATOR

! WARNING

Suffocation Hazard

Remove doors from your old refrigerator.

Failure to do so can result in death or brain damage.

IMPORTANT: Child entrapment and suffocation are not problems of the past. Junked or abandoned refrigerators are still dangerous – even if they will sit for “just a few days.” If you are getting rid of your old refrigerator, please follow these instructions to help prevent accidents.

Before You Throw Away Your Old Refrigerator:

- Take off the door.
- Leave the racks in place so that children may not easily climb inside.

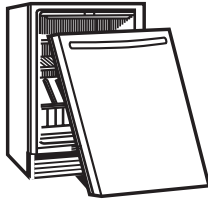

Important information to know about disposal of refrigerants:

Dispose of refrigerator in accordance with Federal and Local regulations. Refrigerants must be evacuated by a licensed, EPA certified refrigerant technician in accordance with established procedures.

FEATURES

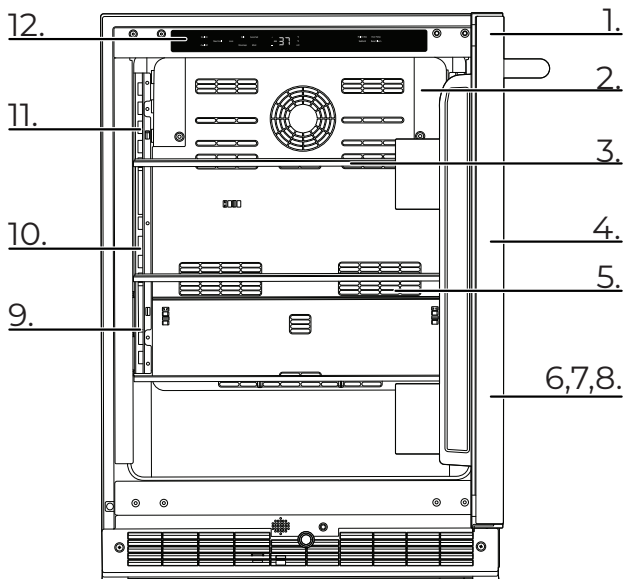

1. Stealth Flush Design with Smooth Close Door

Create an unbroken silhouette. Discreet 1/8" reveals envelop every side, without exposed hinges or trim pieces. Quiet, soft, secure. An articulating hinge discreetly ushers the door open and gently pulls it closed.

2. Daring Obsidian Interior

Inspired by volcanic glass, this dark finish erupts with reflective, high-contrast style. Let the object of your desire emerge like vibrant art, begging to be consumed.

3. Glass Shelves

Gaze through platforms of glass wrapped in unyielding shelf frames.

4. UV-Resistant Low-E Thermal Glass

Sustain what satiates. Double-paned glass helps filter out ultraviolet light and rejects temperature swings to reserve the finest tastes for your discerning palate.

5. LED Lighting

LED lights instinctively come alive, chasing away shadows to reveal vivid details.

6. RISE™ Design Expression

Embrace an era of striking proportions. A stainless steel suit of armor gleams with spectacular light. This is strength—inextricable from beauty. Forged in the fires of progress, the RISE™ design expression towers over stagnant, uninspired designs that have inherited undeserved standing.

7. NOIR™ Design Expression

Lose yourself in a world that's yours alone. Crisp silhouettes crackle with mystique; beguiling reflections flow in and out of sight. Taut with ceaseless allure and minimalist appeal, the NOIR™ design expression rejects dated ideals of beauty.

8. Custom Panel Overlay

Break free with custom panels that allow unapologetic expression. Custom panels and handles must be purchased separately.

9. Door Open Alarm

Helps protect food by giving an audio and visual alert if the door is left open for 10 minutes.

10. Display Lighting Option

Features energy-efficient LED lights that provide a clear view without excessive heat that can affect internal temperatures.

11. Hushed Acoustics

Our internal compressor keeps your beverages impeccably chilled, while running unobtrusively in the background. Brilliance doesn't have to announce itself; it just is.

12. Emotive Controls

Hold sway over every zone. Let your light-guided touch coax out the flavors of beverages, spirits and beyond.

INSTALLATION REQUIREMENTS

TOOLS AND PARTS

Gather the required tools and parts before starting installation

TOOLS AND PARTS NEEDED:

- Phillips screwdriver
- Custom Overlay Door Panel — Refer “ Custom Overlay Panel Preparation.”
- Custom handle and mounting hardware (optional)

PARTS SUPPLIED:

- M4 x 30 flathead screws (8)

LOCATION REQUIREMENTS

⚠ WARNING



Explosion Hazard

Keep flammable materials and vapors, such as gasoline, away from refrigerator.

Failure to do so can result in death, explosion, or fire.

IMPORTANT: This appliances is intended to be used in household and similar applications such as:

- Staff kitchen areas in shops, office and other working environments;
- Farm houses and by clients in hotels, motels and other residential type environments;
- Bed and breakfast type environments;
- Catering and similar non-retail applications.

NOTES:

- For the refrigerator to be flush with the front of the base cabinets, remove any baseboards or moldings from the rear of the opening. Refer “Product Dimensions” and later in this section, “Opening Dimensions.”
- It is recommended that you do not install the refrigerator near an oven, radiator, or other heat source.
- Do not install in a location where the temperature will fall below 55°F (13°C). For best performance, do not install the refrigerator behind a cabinet door or block the base grille.

OPENING DIMENSIONS

- Height dimensions are shown with the leveling legs extended to the minimum height.

NOTE: When leveling legs are fully extended, add 5/8" (15 mm) to the height dimensions. Refer “Product Dimensions.”
- If the floor of the opening is not level with the kitchen floor, shim the opening to make it level with the kitchen floor.

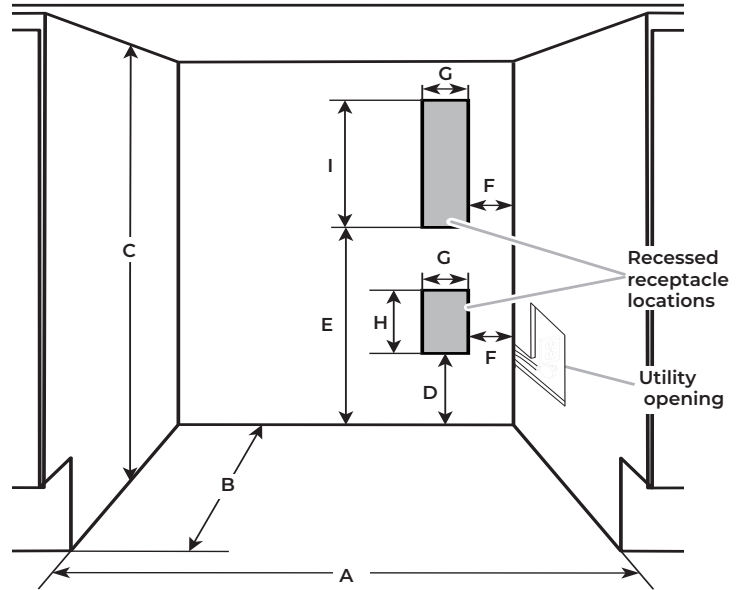

Opening and utility location dimensions

| | |
|--------------------|---|
| Opening width - A | 24" (60.96 cm) min. |
| Opening depth - B | 24" (60.96 cm) min. |
| Opening height - C | 34½" (87.6 cm) min. 35" (88.9 cm) max. |
| Dimension - D | 12¼" (30.64 cm) |
| Dimension - E | 21¾" (55.16 cm) |
| Dimension - F | 1¾" (4.44 cm) |
| Dimension - G | 3" (7.55 cm) |
| Dimension - H | 4½" (11.37 cm) |
| Dimension - I | 9¼" (23.47 cm) |

For flush installation, the power outlet can be installed in adjacent cabinetry with a cutout on the power cord side for routing of the power cord.

The power outlet can also be recessed on the back wall behind the unit as per recommended receptacle locations in the above illustration.

PRODUCT DIMENSIONS

OVERALL PRODUCT

| | |
|--|--|
| Width (up to hinge cover) | 23 ⁷ / ₈ " (60.72 cm) |
| Height (up to hinge cover) | 34 ³ / ₈ " (87.32 cm) |
| Glass door model (NOIR™) depth (no handle) | 23 ³ / ₄ " (60.36 cm) |
| Glass door model (RISE™) depth (no handle) | 23 ⁵ / ₈ " (60 cm) |
| Solid door models (NOIR™/ RISE™) | 23 ⁵ / ₈ " (60 cm) |
| Panel ready models depth (with 3/4" panel and no handle) | 23 ¹³ / ₁₆ " (60.5 cm) |
| Raw Door Height | 30 ⁵ / ₈ " (77.75 cm) |

NOTE: The power cord is 60" (152.4 cm) long.

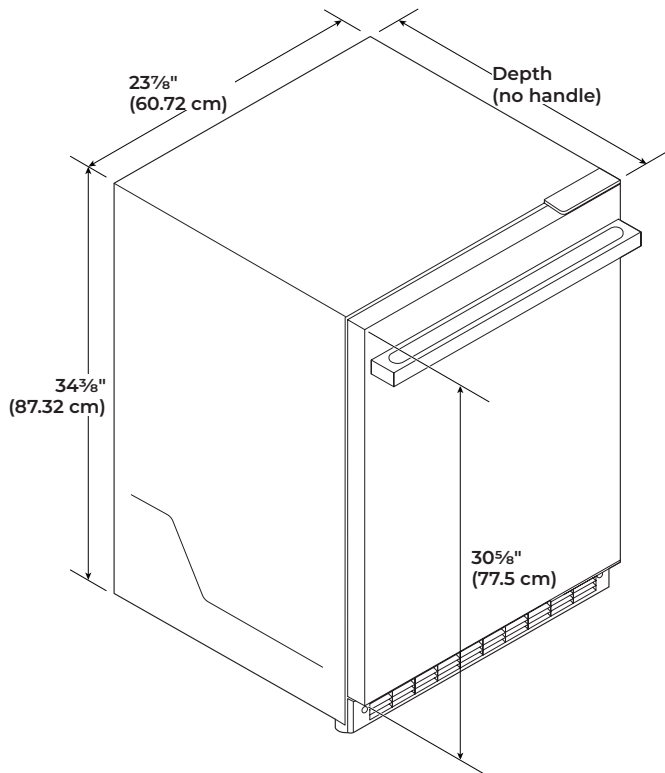

SOLID DOOR OVERLAY PANEL — PREPARATION

Create the custom overlay panel using the dimensions shown in the illustration "Solid door overlay panel and hinge routing dimensions". Rout shaded areas to a 1/2" (12 mm) depth as shown.

IMPORTANT: The following graphic shows a custom panel for a door with the hinges installed on the right-hand side. If your refrigerator has the hinges installed on the left-hand side, rotate the custom frame 180° so the hinge markings will be on the left.

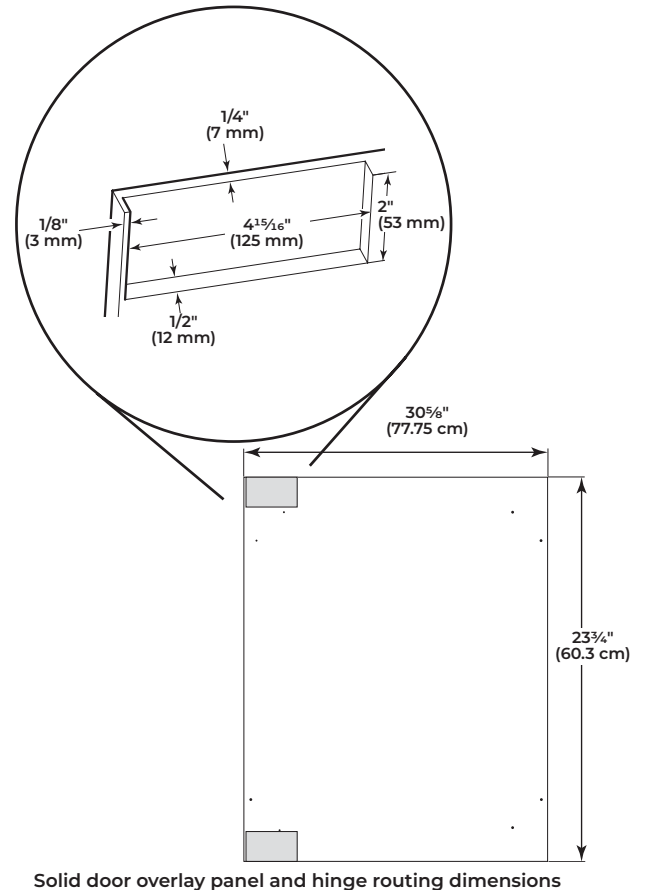

CUSTOM OVERLAY PANEL

NOTE: For standard stainless steel or glass door models, skip these instructions and go to "Electrical Requirements" section.

If you plan to install a custom overlay panel, you will need to create the panel yourself or consult a qualified cabinetmaker or carpenter. Refer dimension drawings for panel specifications.

IMPORTANT:

- The thickness of the overlay panel must be 3/4" (19 mm).
- Custom solid door overlay panel must not weigh more than 20 lbs (9.07 kg).
- Custom solid door overlay panel must not weigh more than 10 lbs (4.54 kg).
- Overlay panels weighing more than recommended may cause damage to your appliance.

GLASS DOOR OVERLAY PANEL — PREPARATION

Create the custom overlay panel using the dimensions shown in the illustration "Glass door overlay panel and hinge routing dimensions". Rout shaded areas to a 1/2" (12 mm) depth as shown.

IMPORTANT: The following graphic shows a custom panel for a door with the hinges installed on the right-hand side. If your refrigerator has the hinges installed on the left-hand side, rotate the custom frame 180° so the hinge markings will be on the left.

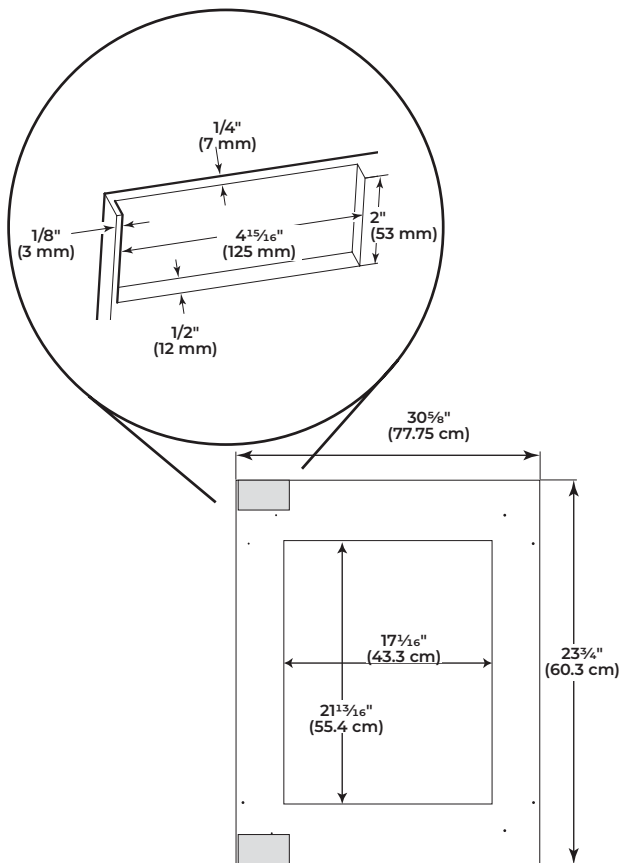

Glass door overlay panel and hinge routing dimensions

HANDLE (OPTIONAL)

Custom handles are typically attached to the custom overlay door panel only.

Refer instructions received with JennAir RISE™ and NOIR™ handle kits to install these handles on custom wood panels.

Custom handle needs to be installed on the door panel with countersunk holes and installed before the custom overlay door panel has been installed on the refrigerator door.

ELECTRICAL REQUIREMENTS

⚠ WARNING



Electrical Shock Hazard

Plug into a grounded 3 prong outlet.

Do not remove ground prong.

Do not use an adapter.

Do not use an extension cord.

Failure to follow these instructions can result in death, fire, or electrical shock.

Before you move your refrigerator into its final location, it is important to make sure you have the proper electrical connection.

RECOMMENDED GROUNDING METHOD

A 115 V, 60 Hz, AC only, 15 or 20 A fused, grounded electrical supply is required. It is recommended that a separate circuit serving only your refrigerator be provided. Use an outlet that cannot be turned off by a switch. Do not use an extension cord.

NOTE: Before performing any type of installation, cleaning, or removing a light bulb, unplug refrigerator or disconnect power.

INSTALLATION INSTRUCTIONS

UNPACK THE REFRIGERATOR

⚠ WARNING

Excessive Weight Hazard

Use two or more people to move and install refrigerator.

Failure to do so can result in back or other injury.

Before using your refrigerator, all packaging materials should be removed and the interior should be cleaned.

- Remove tape and glue residue from surfaces before turning on the refrigerator. With your fingers, rub a small amount of liquid dish soap over any adhesive and wipe with warm water to remove.
- Do not use sharp instruments, rubbing alcohol, flammable fluids, or abrasive cleaners to remove tape or glue. These can damage the surfaces of your refrigerator. For more information, refer "Refrigerator Safety" section.

- Dispose of and/or recycle all packaging materials.
- After all packaging materials have been removed, clean the inside of your refrigerator. Refer the cleaning instructions in "Cleaning" section.

Important information to know about glass shelves and covers:

Do not clean glass shelves or covers with warm water when they are cold. Shelves and covers may break if exposed to sudden temperature changes or impact, such as bumping. Tempered glass is designed to shatter into many small, pebble-size pieces. This is normal. Glass shelves and covers are heavy. Use both hands when removing them to avoid dropping.

NOTE: For standard stainless steel or glass door models, skip to "Door Closing" section.

CUSTOM OVERLAY PANEL INSTALLATION

IMPORTANT:

- Create custom overlay panel according to the specifications in the “Custom Overlay Panel” section.
- JennAir is not responsible for the removal or addition of molding or decorative panels that would not allow access to the refrigerator for service.

1. Open the door completely to 90°.

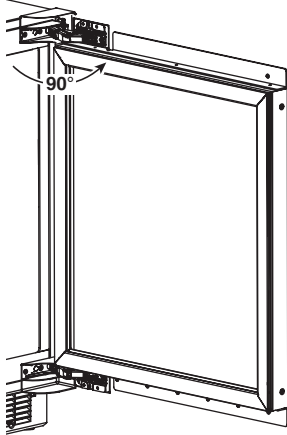

2. Remove the gasket from the corners of the door, pulling gently until the two screw holes in each corner of the door can be seen.

NOTE: The gasket does not have to be removed from the door, only the corners.

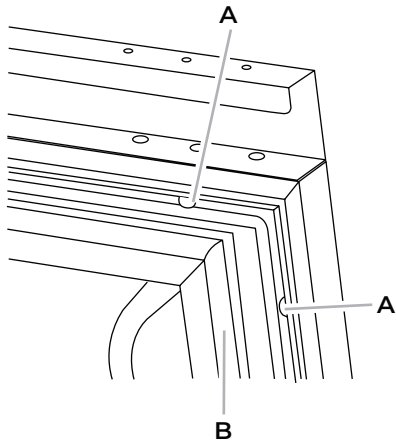

A. Screw holes
B. Gasket

3. Using two people, hold the custom overlay panel against the door. Be sure that the top and bottom hinges fit accurately into the routing on back of the custom wood panel.

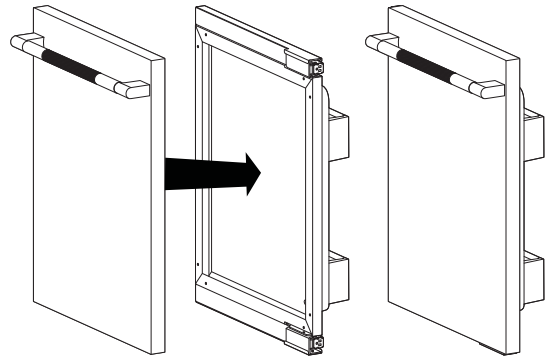

NOTE: Handle needs to be installed before the custom overlay door panel has been installed on the refrigerator door.

4. Fasten the custom panel to the door using two wood screws (provided in installation kit) at each corner.

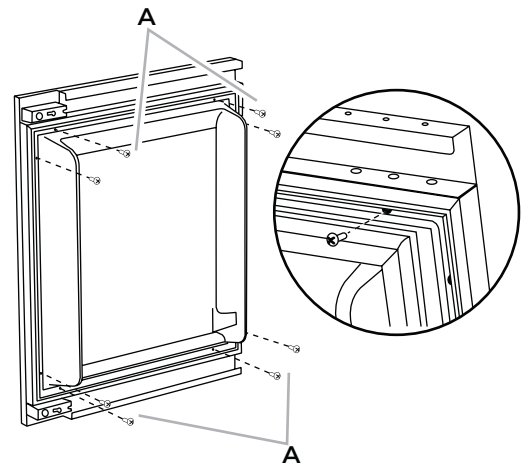

A. M4 x 30 flathead screws (provided in installation kit)

5. Press the gasket firmly back into its original position.

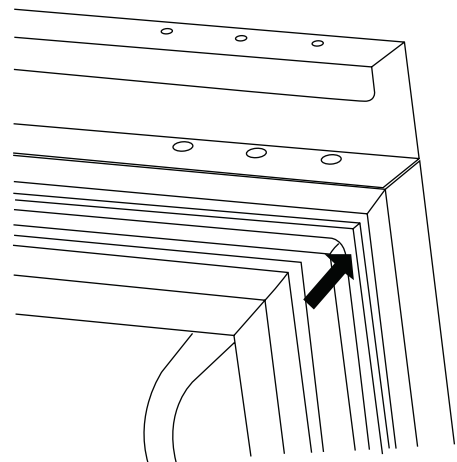

INSTALLATION AND DOOR CLOSING

Your refrigerator has four leveling legs. If your refrigerator seems unsteady or you want the door to close more easily, adjust the refrigerator's tilt using the instructions below.

⚠️ WARNING



Electrical Shock Hazard

Plug into a grounded 3 prong outlet.

Do not remove ground prong.

Do not use an adapter.

Do not use an extension cord.

Failure to follow these instructions can result in death, fire, or electrical shock.

1. Plug into a grounded 3 prong outlet.
2. Move the refrigerator into its final location.
3. Turn the leveling legs to the right to lower the refrigerator, or turn the leveling legs to the left to raise it. It may take several turns of the leveling legs to adjust the tilt of the refrigerator.

NOTE: Having someone push against the top of the refrigerator takes some weight off the leveling legs. This makes it easier to adjust the leveling legs.

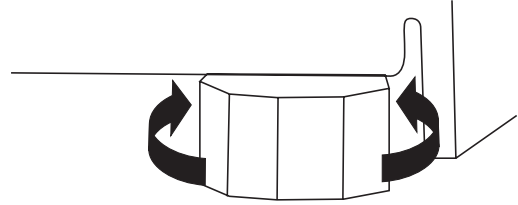

4. Open the door and check that it closes as easily as you like. If not, tilt the refrigerator slightly more to the rear by turning both front leveling screws to the right. It may take several more turns, and you should turn both leveling legs the same amount.

USING REFRIGERATOR

CONTROLS

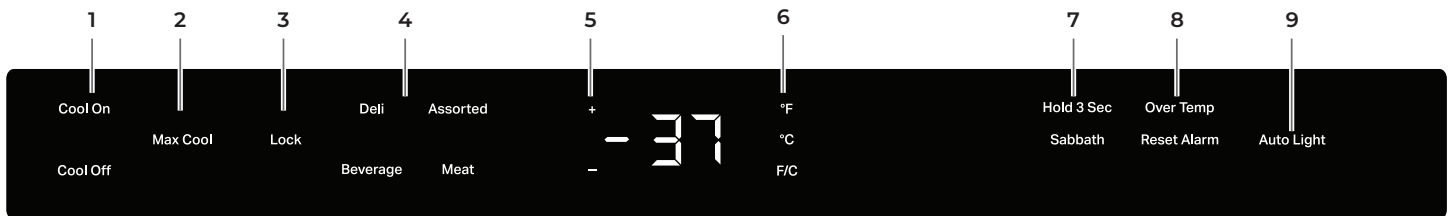

NOTE:

- The control panel is located at the top of the compartment and facing front.
- The control of the refrigerator has no mechanical parts or buttons. When disconnected, the control panel displays nothing and may be difficult to locate.

1. Turning Control On/Off

The first time that the refrigerator is plugged in, the control will be in Cool Off mode. Cool On and Cool Off will be the only options that display.

Press COOL ON for 3 seconds to turn on the refrigerator. All menus and recommended temperature settings will be displayed.

2. Max Cool

Plummet internal temperatures to their lowest point for 24 hours.

- Press Max Cool to turn on the feature. The feature will activate.
- Press Max Cool to turn off the feature and return to the previous settings.

3. Control Lock

Avoids unintended temperature changes and makes it easy to clean the controls.

- To activate Lock Mode, press and hold LOCK for 3 seconds. After the countdown, all other displays will turn off and become unavailable except Cool On, Cool Off and Lock.

4. Using Presets

For your convenience, your refrigerator also has controls that are preset to recommended storage temperatures for specific products. Pressing any preset option will set the temperature value to recommended temperature for each category:

- Deli: 39°F (3°C)
- Assorted: 37° (2°C)
- Beverage: 34°F (1°C)
- Meat: 32°F (0°C)

5. Adjusting the Temperatures

To adjust set point temperatures, press "+" (plus) or "-" (minus) until the desired temperature setting is reached. The control is set correctly when milk and beverages are as cold as you like it.

NOTE:

- The default recommended temperature for the refrigerator is 37°F (2°C). The set point range for this model is 32°F to 42°F (0°C to 5°C).
- Wait at least 24 hours between adjustments so the refrigerator can acclimate.

6. Viewing Celsius/Fahrenheit Temperatures

Press the F/C touch pad to toggle between displaying the temperature in degrees Fahrenheit and degrees Celsius. The corresponding indicator will illuminate.

7. Sabbath Mode

Allows the door of the refrigerator to be opened or closed on the Sabbath or other religious holidays without directly turning on or off any lights, digital readouts, fans, valves, tones or alarms. By selecting this feature, the temperature set points remain unchanged, but the control panel lights, interior lights, and control audio turn off. For most efficient refrigerator operation, it is recommended to exit the Sabbath Mode when it is no longer required.

- Press and hold SABBATH for 3 seconds to turn on the feature. After the 3-second countdown, the feature will activate and all other displays will turn Off.
- Press and hold SABBATH for 3 seconds to turn off the feature and turn on the display.

8. Over Temp Alarm

Helps avoid food from spoiling by giving an audible and visual alert if the temperature in either zone rises above the preset range for 10 minutes.

The audio alarm will shut off automatically when the temperature returns to normal. To let you know an Over Temperature condition occurred, the indicator light will continue to flash until the Reset Alarm touch pad is pressed. If the over temperature condition is still present when an Over Temp reset is performed, the indicator light will continue to reactivate every 4 hours until the refrigerator temperature is below preset range.

NOTE: These features will not appear on your control unless your refrigerator is above preset range and the alarm requires a reset.

9. Auto Light (Glass Door Models)

The refrigerator has a sensor that will turn on the interior display light automatically when someone walks by. When motion is no longer detected, the interior display light will go off after 2 minutes.

- Press the Auto Light option to activate this feature.
- When the Auto Light is not activated, the interior display light will only turn on when the door is opened.

NOTE:

- Leaving the light on for an extended period of time will slightly increase the temperature of the refrigerator.

10. Door Open Alarm

Helps avoid food from spoiling by giving an audio and visual alert if the door is left open for 10 minutes.

If the door is open longer than 10 minutes, an alarm will sound every 2 minutes until the door is closed or any control is pressed.

11. Showroom Mode

This mode is used only when the refrigerator is on display in a retail store. If you unintentionally turn on Showroom Mode, Cool Off will light up on the display, and the controls will appear to work. Exit Showroom Mode by pressing and holding COOL ON and SABBATH at the same time for 3 seconds.

NORMAL SOUNDS

Your new refrigerator may make sounds that your old one didn't make. Because the sounds are new to you, you might be concerned about them. Most of the new sounds are normal. Hard surfaces, such as the flooring and surrounding structures, can make the sounds seem louder. The following describes the kinds of sounds and what may be making them.

- Your refrigerator is designed to run more efficiently to keep your food at the desired temperatures and to minimize energy usage. The high efficiency compressor and fans may cause your refrigerator to run longer than your old one. You may also hear a pulsating or high-pitched sound from the compressor or fans adjusting to optimize performance.
- Rattling noises may come from the flow of refrigerant or items stored inside the refrigerator.
- As each cycle ends, you may hear a gurgling sound due to the refrigerant flowing in your refrigerator.
- You may hear water running into the drain pan when the refrigerator is defrosting.
- You may hear clicking sounds when the refrigerator starts or stops running.

REFRIGERATOR SHELVES

TO REMOVE OR ADJUST UPPER SHELVES:

1. Remove the shelf by lifting it up and out of the shelf brackets.

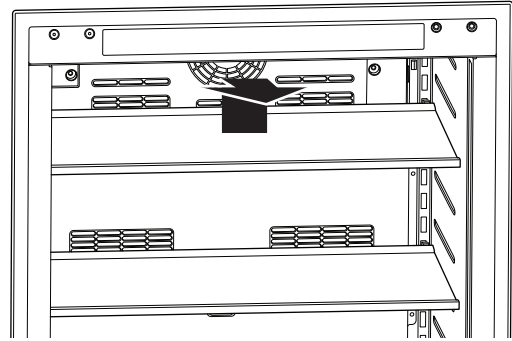

2. Remove the two shelf brackets and reposition them in the desired location.

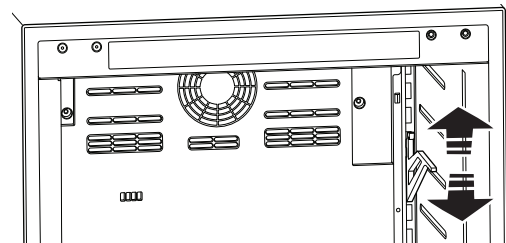

3. Replace the shelf by inserting it into the shelf brackets.

NOTE: Be sure the shelf is level.

TO REMOVE AND REPLACE BOTTOM SHELF:

1. The very bottom glass shelf slides straight out.

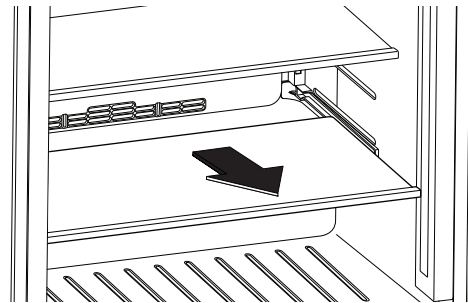

2. Replace the shelf by aligning the edges with the guides and pushing it in toward the back of the refrigerator.

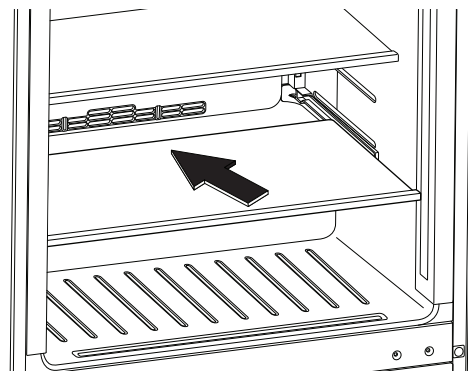

DOOR BINS (SOLID DOOR MODELS)

Your refrigerator has two door bin locations for maximum storage capacity.

TO REMOVE AND REPLACE THE DOOR BINS:

1. Remove the door bin by tilting it forward and pulling it out.
2. Replace the bin by placing the rear of the bin under the support on the door and sliding into place.

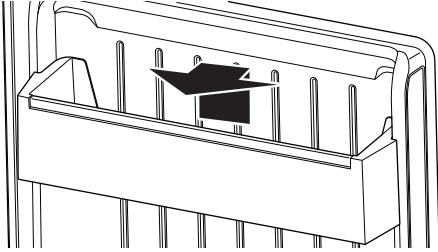

LIGHTS

The refrigerator has an interior light that illuminates when the door is opened.

NOTE: The light is an LED which does not need to be replaced. If the LED does not illuminate when the door is opened, call Service. Refer "Assistance" section for contact information.

CARE AND CLEANING

CLEANING

⚠ WARNING



Explosion Hazard

Use nonflammable cleaner.

Failure to do so can result in death, explosion, or fire.

Clean the refrigerator once a month to avoid buildup of odors. Wipe up spills immediately.

TO CLEAN YOUR REFRIGERATOR:

1. Unplug refrigerator or disconnect power.
2. Remove all shelves and bins from inside the refrigerator.
3. Hand wash, rinse, and dry removable parts and interior surfaces thoroughly. Use a clean sponge or soft cloth and a mild detergent in warm water.
 - To avoid damaging wooden tines and trim pieces, wipe them off with a clean sponge or soft cloth and warm water. Do not use detergent or immerse the entire rack into water when cleaning.
 - Do not use abrasive or harsh cleaners such as window sprays, scouring cleansers, flammable fluids, cleaning waxes, concentrated detergents, bleaches or cleansers containing petroleum products on plastic parts, interior and door liners or gaskets. Do not use paper towels, scouring pads, or other harsh cleaning tools. These can scratch or damage materials.
 - To help remove odors, you can wash interior walls with a mixture of warm water and baking soda (2 tbs to 1 qt [26 g to 0.95 L] of water).
4. Wash stainless steel and painted metal exteriors with

a clean sponge or soft cloth and a mild detergent in warm water. Do not use abrasive or harsh cleaners, or cleaners containing chlorine. These can scratch or damage materials. Dry thoroughly with a soft cloth.

NOTE: To keep your stainless steel refrigerator looking like new and to remove minor scuffs or marks, it is recommended that you use the manufacturer's approved Stainless Steel Cleaner and Polish.

IMPORTANT:

- This cleaner is for stainless steel parts only!
 - Do not allow the Stainless Steel Cleaner and Polish to come into contact with any plastic parts such as the trim pieces, dispenser covers or door gaskets. If unintentional contact does occur, clean plastic part with a sponge and mild detergent in warm water. Dry thoroughly with a soft cloth.
5. Replace the shelves and bins.
 6. Clean the condenser coils regularly. They are located behind the base grille. Coils may need to be cleaned as often as every other month. This may help save energy.
 - Remove the base grille to access condenser for cleaning. Refer "Removing Base Grille" section.

REMOVING BASE GRILLE

You must remove the base grille to access the condenser coils for cleaning.

TO REMOVE THE BASE GRILLE:

1. Open the refrigerator door.

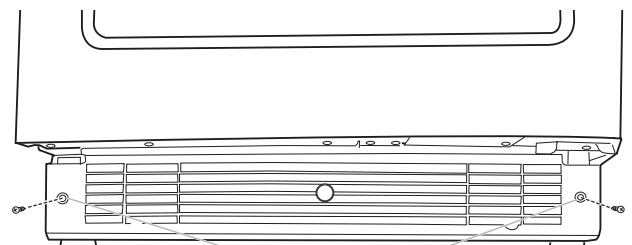

A. Screws

- Using a Phillips screwdriver, remove the two screws.
- Remove the base grille.

TO REPLACE THE BASE GRILLE:

- Open the refrigerator door.
- Position the base grille so that both tabs align and the base grille snaps into place. Replace two screws. Tighten the screws.

VACATION CARE

If you choose to turn the refrigerator off before you leave, follow these steps.

- Remove all food from the refrigerator.
- Unplug the refrigerator.
- Clean the refrigerator. Refer “Cleaning” section.
- Tape a rubber or wood block to the top of the door

to prop it open far enough for air to get in. This stops odor and mold from building up.

MOVING CARE

When you are moving your refrigerator to a new home, follow these steps to prepare it for the move.

- Remove all food from the refrigerator.
- Unplug the refrigerator.
- Clean, wipe, and dry it thoroughly.
- Take out all removable parts, wrap them well, and tape them together so they don't shift and rattle during the move.
- Tape the doors shut and tape the power cord to the refrigerator.

When you get to your new home, put everything back and refer to the “Installation Instructions” section.

TROUBLESHOOTING

Try the solutions suggested here first in order to avoid the cost of an unnecessary service call.

OPERATION

⚠ WARNING



Electrical Shock Hazard

Plug into a grounded 3 prong outlet.

Do not remove ground prong.

Do not use an adapter.

Do not use an extension cord.

Failure to follow these instructions can result in death, fire, or electrical shock.

- **Power supply cord unplugged?** Plug into a grounded 3 prong outlet.
- **Is outlet working?** Plug in a lamp to see if the outlet is working.
- **Household fuse blown, or a circuit breaker tripped?** Replace the fuse or reset the circuit. If the problem continues, call an electrician.
- **Are controls on?** Be sure that the refrigerator controls are on. Refer “Controls” section.

THE MOTOR SEEMS TO RUN TOO MUCH

- **Is the temperature outside hotter than normal?** Expect the motor to run longer under warm conditions. At normal temperatures, expect your motor to run about 40% to 80% of the time. Under warmer conditions, expect it to run even more of the time.
- **Has a large amount of food just been added to the refrigerator?** Adding a large amount of food warms the refrigerator. It is normal for the motor to run longer in order to cool the refrigerator back down.
- **Is the door opened often?** Expect the motor to run

longer when this occurs. In order to conserve energy, try to get everything you need out of the refrigerator at once, keep food organized so it is easy to find, and close the door as soon as the food is removed.

- **Is the control set correctly for the surrounding conditions?** Refer “Controls” section.
- **Is the door closed completely?** Push the door firmly shut. If it will not shut all the way, refer “The door will not close completely” later in this section.
- **Are the condenser coils dirty?** This obstructs air transfer and makes the motor work harder. Clean the condenser coils. Refer “Cleaning” section.

TEMPERATURE AND MOISTURE

TEMPERATURE IS TOO WARM

- **Is the door opened often?** Be aware that the refrigerator will warm up when this occurs. In order to keep the refrigerator cool, try to get everything you need out of the refrigerator at once, keep food organized so it is easy to find, and close the door as soon as the food is removed.
- **Has a large amount of food just been added to the refrigerator?** Adding a large amount of food warms the refrigerator. It can take several hours for the refrigerator to return to the normal temperature.
- **Is the control set correctly for the surrounding conditions?** Refer “Using the Controls.”
- **Is the base grille blocked?** For best performance, do not install the refrigerator behind a cabinet door or block the base grille.

THERE IS INTERIOR MOISTURE BUILDUP

- **Is the door opened often?** To avoid humidity buildup, try to get everything you need out of the refrigerator at once, keep food organized so it is easy to find, and close the door as soon as the food is removed. When the door is opened, humidity from the room air enters the refrigerator. The more often the door is opened, the faster humidity builds up, especially when the room itself is very humid.
- **Is it humid?** It is normal for moisture to build up inside the refrigerator when the air is humid.

- **Is the food packaged correctly?** Check that all food is securely wrapped. Wipe off damp food containers before placing in the refrigerator.
- **Is the control set correctly for the surrounding conditions?** Refer “Controls” section.

DOOR

THE DOOR IS DIFFICULT TO OPEN

| |
|---|
| ⚠ WARNING |
|  |
| Explosion Hazard |
| Use nonflammable cleaner. |
| Failure to do so can result in death, explosion, or fire. |

- **Is the gasket dirty or sticky?** Clean the gasket and the surface that it touches. Rub a thin coat of paraffin wax on the gasket following cleaning.

THE DOOR WILL NOT CLOSE COMPLETELY

- **Are food packages blocking the door open?** Rearrange containers so that they fit more tightly and take up less space.
- **Are the shelves out of position?** Put the shelves back into their correct positions. Refer “Refrigerator Use” for more information.

| |
|---|
| ⚠ WARNING |
|  |
| Explosion Hazard |
| Use nonflammable cleaner. |
| Failure to do so can result in death, explosion, or fire. |

- **Is the gasket sticking?** Clean the gasket and the surface that it touches. Rub a thin coat of paraffin wax on the gasket following cleaning.

ASSISTANCE

IF YOU NEED SERVICE

Before calling for assistance or service, please check “Troubleshooting.” It may save you the cost of a service call. If you still need help, follow the instructions below.

When calling, please know the purchase date and the complete model and serial number of your appliance. This information will help us to better respond to your request. Please refer to the warranty page in this manual for more information on service.

IF YOU NEED REPLACEMENT PARTS

Component parts should be replaced with like components and servicing should be done by factory authorized service personnel, so as to minimize the risk of possible ignition due to incorrect parts or improper service.

IN THE U.S.A.

Call the JennAir Customer eXperience Center toll free at **1-800-JENNAIR (1-800-536-6247)**, or visit our website at **www.jennair.com**.

OUR CONSULTANTS PROVIDE ASSISTANCE WITH:

- Features and specifications on our full line of appliances.
- Installation information.
- Use and maintenance procedures.
- Accessory and repair parts sales.
- Specialized customer assistance (Spanish speaking, hearing impaired, limited vision, etc.).
- Referrals to local dealers, repair parts distributors, and service companies. JennAir designated service technicians are trained to fulfill the product warranty and provide after warranty service, anywhere in the United States.

To locate the JennAir designated service company in your area, you can also look in your telephone directory Yellow Pages.

FOR FURTHER ASSISTANCE

If you need further assistance, you can write to JennAir with any questions or concerns at:

JennAir Brand Home Appliances
Customer eXperience Center
553 Benson Road
Benton Harbor, MI 49022-2692

Please include a daytime phone number in your correspondence.

IN CANADA

Call the JennAir Canada Customer eXperience Centre toll free: **1-800-JENNAIR (1-800-536-6247)**.

OUR CONSULTANTS PROVIDE ASSISTANCE WITH:

- Features and specifications on our full line of appliances.
- Use and maintenance procedures.
- Accessory and repair parts sales.
- Referrals to local dealers, repair parts distributors, and services companies. JennAir Canada designated service technicians are trained to fulfill the product warranty and provide after-warranty service, anywhere in Canada.

FOR FURTHER ASSISTANCE

If you need further assistance, you can write to JennAir Canada with any questions or concerns at:

JennAir Canada
Customer eXperience Centre
200 – 6750 Century Ave.
Mississauga, Ontario L5N 0B7

Please include a daytime phone number in your correspondence.

JENNAIR® REFRIGERATION LIMITED WARRANTY

ATTACH YOUR RECEIPT HERE. PROOF OF PURCHASE IS REQUIRED TO OBTAIN WARRANTY SERVICE.

Please have the following information available when you call the Customer eXperience Center:

- Name, address, and telephone number
- Model number and serial number
- A clear, detailed description of the problem
- Proof of purchase including dealer or retailer name and address

IF YOU NEED SERVICE:

1. Before contacting us to arrange service, please determine whether your product requires repair. Some questions can be addressed without service. Please take a few minutes to review the Troubleshooting section of the Use and Care Guide or visit producthelp.jennair.com.
2. All warranty service is provided exclusively by our authorized JennAir Service Providers. In the U.S. and Canada, direct all requests for warranty service to:

**JennAir Customer eXperience Center
1-800-JENNAIR (1-800-536-6247).**

If outside the 50 United States or Canada, contact your authorized JennAir dealer to determine whether another warranty applies.

TEN YEAR LIMITED WARRANTY

WHAT IS COVERED

TWO YEAR LIMITED WARRANTY (PARTS AND LABOR)

For two years from the date of purchase, when this major appliance is installed, operated and maintained according to instructions attached to or furnished with the product, JennAir brand of Whirlpool Corporation or Whirlpool Canada LP (hereafter "JennAir") will pay for Factory Specified Replacement Parts and repair labor to correct defects in materials or workmanship that existed when this major appliance was purchased, or at its sole discretion replace the product. In the event of product replacement, your appliance will be warranted for the remaining term of the original unit's warranty period.

THIRD THROUGH FIFTH YEAR LIMITED WARRANTY (SEALED REFRIGERATION SYSTEM PARTS ONLY – LABOR NOT INCLUDED)

In the third through fifth years from the date of purchase, when this major appliance is installed, operated and maintained according to the instructions attached to or furnished with the product, JennAir brand will pay for factory specified replacement parts and repair labor for the following components to correct non-cosmetic defects in materials and workmanship in this part that prevent function of the refrigerator and that existed when this major appliance was purchased:

- Refrigerator/freezer cavity liner if the part cracks due to defective materials or workmanship.
- Sealed Refrigeration system (includes compressor, evaporator, condenser, dryer and connecting tubing).

SIXTH THROUGH TENTH YEAR LIMITED WARRANTY (SEALED REFRIGERATION SYSTEM ONLY - LABOR NOT INCLUDED)

In the sixth through tenth year from the date of purchase, when this major appliance is installed, operated and maintained according to instructions attached to or furnished with the product, JennAir brand will pay for factory specified replacement parts for the following components to correct defects in materials or workmanship in the sealed refrigeration system (includes compressor, evaporator, condenser, dryer and connecting tubing) that existed when this major appliance was purchased.

YOUR SOLE AND EXCLUSIVE REMEDY UNDER THIS LIMITED WARRANTY SHALL BE PRODUCT REPAIR AS PROVIDED HEREIN. Service must be provided by a JennAir designated service company. This limited warranty is valid only in the United States or Canada and applies only when the major appliance is used in the country in which it was purchased. This limited warranty is effective from the date of original consumer purchase. Proof of original purchase date is required to obtain service under this limited warranty.

WHAT IS NOT COVERED

1. Commercial, non-residential or multiple-family use, or use inconsistent with published user, operator or installation instructions.
2. In-home Instruction on how to use your product.
3. Service to correct improper product maintenance or installation, installation not in accordance with electrical or plumbing codes or correction of household electrical or plumbing (i.e. house wiring, fuses or water inlet hoses).
4. Consumable parts (i.e. light bulbs, batteries, air or water filters, preservation solutions, etc.).
5. Defects or damage caused by the use of non-genuine JennAir parts or accessories.
6. Damage from accident, misuse, abuse, fire, floods, acts of God or use with products not approved by JennAir.
7. Repairs to parts or systems to correct product damage or defects caused by unauthorized service, alteration or modification of the appliance.
8. Cosmetic damage including scratches, dents, chips, and other damage to appliance finishes unless such damage results from defects in materials and workmanship and is reported to JennAir within 30 days.
9. Discoloration, rust or oxidation of surfaces resulting from caustic or corrosive environments including but not limited to high salt concentrations, high moisture or humidity or exposure to chemicals.
10. Food or medicine loss due to product failure.
11. Pick-up or delivery. This product is intended for in-home repair.
12. Travel or transportation expenses for service in remote locations where an authorized JennAir servicer is not available.
13. Removal or reinstallation of inaccessible appliances or built-in fixtures (i.e. trim, decorative panels, flooring, cabinetry, islands, countertops, drywall, etc.) that interfere with servicing, removal or replacement of the product.
14. Service or parts for appliances with original model/serial numbers removed, altered or not easily determined.

The cost of repair or replacement under these excluded circumstances shall be borne by the customer.

DISCLAIMER OF IMPLIED WARRANTIES

IMPLIED WARRANTIES, INCLUDING ANY IMPLIED WARRANTY OF MERCHANTABILITY OR IMPLIED WARRANTY OF FITNESS FOR A PARTICULAR PURPOSE, ARE LIMITED TO ONE YEAR OR THE SHORTEST PERIOD ALLOWED BY LAW. Some states and provinces do not allow limitations on the duration of implied warranties of merchantability or fitness, so this limitation may not apply to you. This warranty gives you specific legal rights, and you also may have other rights that vary from state to state or province to province.

DISCLAIMER OF REPRESENTATIONS OUTSIDE OF WARRANTY

JennAir makes no representations about the quality, durability, or need for service or repair of this major appliance other than the representations contained in this warranty. If you want a longer or more comprehensive warranty than the limited warranty that comes with this major appliance, you should ask JennAir or your retailer about buying an extended warranty.

LIMITATION OF REMEDIES: EXCLUSION OF INCIDENTAL AND CONSEQUENTIAL DAMAGES

YOUR SOLE AND EXCLUSIVE REMEDY UNDER THIS LIMITED WARRANTY SHALL BE PRODUCT REPAIR AS PROVIDED HEREIN. JENNAIR SHALL NOT BE LIABLE FOR INCIDENTAL OR CONSEQUENTIAL DAMAGES. Some states and provinces do not allow the exclusion or limitation of incidental or consequential damages, so these limitations and exclusions may not apply to you. This warranty gives you specific legal rights, and you also may have other rights that vary from state to state or province to province.

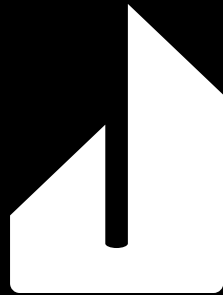

JENNAIR®