

JENNAIR® PRO-STYLE® DUAL FUEL
CONVECTION RANGES
CUISINIÈRE À DOUBLE COMBUSTIBLE
À CONVECTION PRO-STYLE® DE JENNAIR®

Use & Care Guide

For questions about features, operation/performance, parts, accessories, or service in the U.S.A., call
1-800-JENNAIR (1-800-536-6247) or visit our website at www.jennair.com.
In Canada, call **1-800-JENNAIR (1-800-536-6247)** or visit our website at www.jennair.ca.

Guide d'utilisation et d'entretien

Pour des questions à propos des caractéristiques, du fonctionnement/rendement, des pièces, accessoires ou service aux É.-U.,
composer le **1 800 JENNAIR (1 800 536-6247)** ou visiter le www.jennair.com.
Au Canada, composer le **1 800 JENNAIR (1 800 536-6247)** ou visiter le www.jennair.ca.



W11114330C

Table of Contents

















SAFETY INFORMATION	3
 The Anti-Tip Bracket	4
PARTS AND FEATURES	6
 Range	6
Oven Interior.....	7
Control Knobs	7
COOKTOP FEATURES	13
 Burners.....	13
Grill	14
Chrome Electric Griddle.....	15
USING YOUR OVEN	16
 Oven Control Knobs	16
Indicator Lights	16
Oven Use.....	19
Cooking Modes.....	21
Steam-Assisted Cooking	25
CARE AND CLEANING	27
 Cooktop Surface.....	27
Sealed Surface Burners.....	27
Porcelain-Coated Grates and Caps	28
Grill	28
Griddle.....	29
Cooktop Controls.....	30
Stainless Steel.....	30
Door Exterior	31
Door Interior	31
Oven Racks.....	31
Oven Cavity.....	31
Broil Element.....	31
Self-Cleaning the Oven.....	32
Oven Lights	34
TROUBLESHOOTING	35
	
ASSISTANCE OR SERVICE	37
	
ACCESSORIES	37
	

Table de matières

INFORMATIONS DE SÉCURITÉ	38
 La bride antibasculement	39
PIÈCES ET CARACTÉRISTIQUES	41
 Cuisinière.....	41
Intérieur du four.....	42
Boutons de commande	42
CARACTÉRISTIQUES DE LA TABLE DE CUISSON	48
 Brûleurs	48
Gril	49
Plaque à friture chromée.....	50
UTILISATION DU FOUR	51
 Boutons de commande du four.....	51
Témoins lumineux	51
Utilisation du four.....	55
Modes de cuisson.....	57
Cuisson avec injection de vapeur.....	61
ENTRETIEN ET NETTOYAGE	63
 Surface de la table de cuisson	63
Brûleurs de surface scellés.....	63
Grilles et chapeaux émaillés	64
Gril	64
Plaque à friture	65
Commandes de la table de cuisson	66
Acier inoxydable.....	66
Extérieure de la porte.....	67
Intérieur de la porte.....	67
Grilles du four.....	67
Cavité du four.....	67
Élément de cuisson au gril.....	67
Autonettoyage du four	68
Lampes du four.....	70
DÉPANNAGE	71
	
ASSISTANCE OU SERVICE	73
	
ACCESSOIRES	73
	



Your safety and the safety of others are very important.

We have provided many important safety messages in this manual and on your appliance. Always read and obey all safety messages.



This is the safety alert symbol.

This symbol alerts you to potential hazards that can kill or hurt you and others.

All safety messages will follow the safety alert symbol and either the word "DANGER" or "WARNING." These words mean:

⚠ DANGER

You can be killed or seriously injured if you don't immediately follow instructions.

⚠ WARNING

You can be killed or seriously injured if you don't follow instructions.

All safety messages will tell you what the potential hazard is, tell you how to reduce the chance of injury, and tell you what can happen if the instructions are not followed.

WARNING: If the information in these instructions is not followed exactly, a fire or explosion may result causing property damage, personal injury or death.

- Do not store or use gasoline or other flammable vapors and liquids in the vicinity of this or any other appliance.
- **WHAT TO DO IF YOU SMELL GAS:**
 - Do not try to light any appliance.
 - Do not touch any electrical switch.
 - Do not use any phone in your building.
 - Immediately call your gas supplier from a neighbor's phone. Follow the gas supplier's instructions.
 - If you cannot reach your gas supplier, call the fire department.
- Installation and service must be performed by a qualified installer, service agency or the gas supplier.

WARNING: Gas leaks cannot always be detected by smell.

Gas suppliers recommend that you use a gas detector approved by UL or CSA.

For more information, contact your gas supplier.

If a gas leak is detected, follow the "What to do if you smell gas" instructions.



SAFETY INFORMATION

THE ANTI-TIP BRACKET

The range will not tip during normal use. However, the range can tip if you apply too much force or weight to the open door without the anti-tip bracket fastened down properly.



⚠ WARNING

Tip Over Hazard

A child or adult can tip the range and be killed.

Verify the anti-tip bracket has been properly installed and engaged per installation instructions.

Re-engage the anti-tip bracket if the range is moved.

Do not operate range without anti-tip bracket installed and engaged.

Failure to follow these instructions can result in death or serious burns to children and adults.

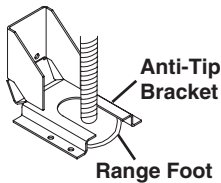

To verify the anti-tip bracket is installed and engaged:

- Slide range forward.
- Look for the anti-tip bracket securely attached to floor or wall.
- Slide range back so rear range foot is under anti-tip bracket.
- See installation instructions for details.

IMPORTANT SAFETY INSTRUCTIONS

WARNING: To reduce the risk of fire, electrical shock, injury to persons, or damage when using the range, follow basic precautions, including the following:

- **WARNING:** TO REDUCE THE RISK OF TIPPING OF THE RANGE, THE RANGE MUST BE SECURED BY PROPERLY INSTALLED ANTI-TIP DEVICES. TO CHECK IF THE DEVICES ARE INSTALLED PROPERLY, SLIDE RANGE FORWARD, LOOK FOR ANTI-TIP BRACKET SECURELY ATTACHED TO FLOOR OR WALL, AND SLIDE RANGE BACK SO REAR RANGE FOOT IS UNDER ANTI-TIP BRACKET.
- **WARNING:** TO REDUCE THE RISK OF BURNS, DO NOT MOVE THE RANGE WHILE HOT. THIS RANGE IS PROVIDED WITH WHEELS TO FACILITATE MOVEMENT. TO REDUCE THE RISK OF INJURY DUE TO TIPPING OF THE APPLIANCE, VERIFY THE REINSTALLATION OF THE RANGE INTO THE ANTI-TIP DEVICE PROVIDED, AND EXTEND LEVELING FEET AFTER RETURNING THE RANGE TO THE ORIGINAL INSTALLED POSITION.
- **WARNING:** NEVER use this appliance as a space heater to heat or warm the room. Doing so may result in carbon monoxide poisoning and overheating of the oven.
- **WARNING:** NEVER cover any slots, holes or passages in the oven bottom or cover an entire rack with materials such as aluminum foil. Doing so blocks air flow through the oven and may cause carbon monoxide poisoning. Aluminum foil linings may also trap heat, causing a fire hazard.
- **CAUTION:** Do not store items of interest to children in cabinets above a range or on the backguard of a range – children climbing on the range to reach items could be seriously injured.
- Do Not Leave Children Alone – Children should not be left alone or unattended in area where the range is in use. They should never be allowed to sit or stand on any part of the range.

- Wear Proper Apparel – Loose-fitting or hanging garments should never be worn while using the range.
- User Servicing – Do not repair or replace any part of the range unless specifically recommended in the manual. All other servicing should be referred to a qualified technician.
- Storage in or on the Range – Flammable materials should not be stored in an oven or near surface units.
- Do Not Use Water on Grease Fires – Smother fire or flame or use dry chemical or foam-type extinguisher.
- Use Only Dry Potholders – Moist or damp potholders on hot surfaces may result in burns from steam. Do not let potholder touch hot heating elements. Do not use a towel or other bulky cloth.
- DO NOT TOUCH SURFACE UNITS OR AREAS NEAR UNITS – Surface units may be hot even though they are dark in color. Areas near surface units may become hot enough to cause burns. During and after use, do not touch, or let clothing or other flammable materials contact surface units or areas near units until they have had sufficient time to cool. Among those areas are the cooktop and surfaces facing the cooktop.
- Never Leave Surface Units Unattended at High Heat Settings – Boilover causes smoking and greasy spillovers that may ignite.
- Glazed Cooking Utensils – Only certain types of glass, glass/ceramic, ceramic, earthenware, or other glazed utensils are suitable for range-top service without breaking due to the sudden change in temperature.

SAVE THESE INSTRUCTIONS



IMPORTANT SAFETY INSTRUCTIONS

- Utensil Handles Should Be Turned Inward and Not Extend Over Adjacent Surface Units – To reduce the risk of burns, ignition of flammable materials, and spillage due to unintentional contact with the utensil, the handle of a utensil should be positioned so that it is turned inward, and does not extend over adjacent surface units.
 - Clean Cooktop With Caution – If a wet sponge or cloth is used to wipe spills on a hot cooking area, be careful to avoid steam burn. Some cleaners can produce noxious fumes if applied to a hot surface.
 - Use Care When Opening Door – Let hot air or steam escape before removing or replacing food.
 - Do Not Heat Unopened Food Containers – Build-up of pressure may cause container to burst and result in injury.
 - Keep Oven Vent Ducts Unobstructed.
 - Placement of Oven Racks – Always place oven racks in desired location while oven is cool. If rack must be moved while oven is hot, do not let potholder contact hot heating element in oven.
 - DO NOT TOUCH HEATING ELEMENTS OR INTERIOR SURFACES OF OVEN – Heating elements may be hot even though they are dark in color. Interior surfaces of an oven become hot enough to cause burns. During and after use, do not touch, or let clothing or other flammable materials contact heating elements or interior surfaces of oven until they have had sufficient time to cool. Other surfaces of the appliance may become hot enough to cause burns – among these surfaces are oven vent openings and surfaces near these openings, oven doors, and windows of oven doors.
 - Proper Installation – The range, when installed, must be electrically grounded in accordance with local codes or, in the absence of local codes, with the *National Electrical Code, ANSI/NFPA 70*. In Canada, the range must be electrically grounded in accordance with Canadian Electrical Code. Be sure the range is properly installed and grounded by a qualified technician.
 - Disconnect the electrical supply before servicing the appliance.
 - Injuries may result from the misuse of appliance doors or drawers such as stepping, leaning, or sitting on the doors or drawers.
 - Maintenance – Keep range area clear and free from combustible materials, gasoline, and other flammable vapors and liquids.
 - Top burner flame size should be adjusted so it does not extend beyond the edge of the cooking utensil.
- For self-cleaning ranges –**
- Do Not Clean Door Gasket – The door gasket is essential for a good seal. Care should be taken not to rub, damage, or move the gasket.
 - Do Not Use Oven Cleaners – No commercial oven cleaner or oven liner protective coating of any kind should be used in or around any part of the oven.
 - Clean Only Parts Listed in Manual.
 - Before Self-Cleaning the Oven – Remove broiler pan and other utensils. Wipe off all excessive spillage before initiating the cleaning cycle.
- For units with ventilating hood –**
- Clean Ventilating Hoods Frequently – Grease should not be allowed to accumulate on hood or filter.
 - When flambéing foods under the hood, turn the fan on.

SAVE THESE INSTRUCTIONS



PARTS AND FEATURES

These instructions cover several different models. The range you have purchased may have some or all of the items listed. The locations and appearances of the features shown here may not match those of your model.

RANGE

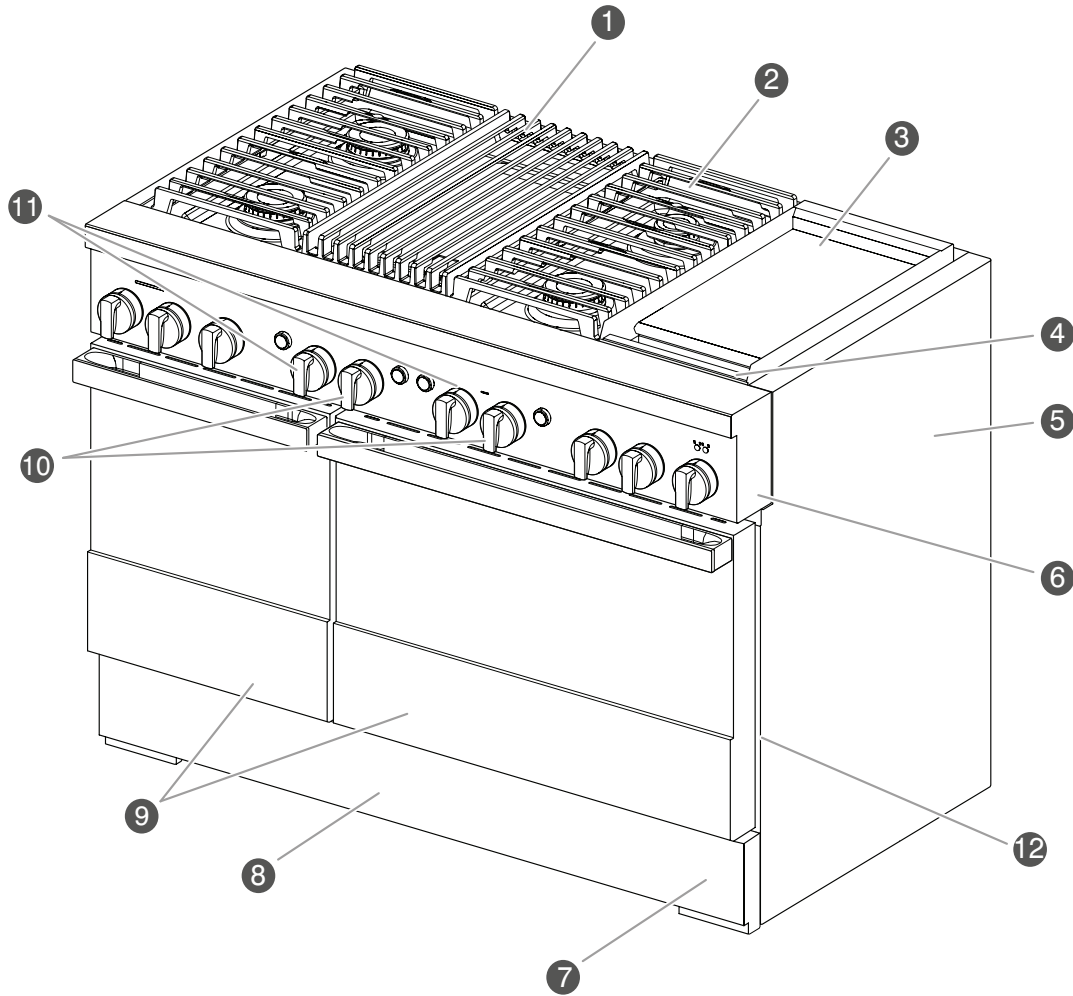

48" (121.9 cm) range shown*

- | | |
|--|--|
| 1 Grill (on some models) | 7 Leveling rods (behind kick plate) |
| 2 Cooktop grate | 8 Lower panel/kick plate |
| 3 Electric griddle (on some models) | 9 Oven doors |
| 4 Drip tray (on griddle models) | 10 Temperature knobs |
| 5 Side panels | 11 Mode knobs |
| 6 Console panel | 12 SAID Label |

*Cooktop configuration may differ.



OVEN INTERIOR

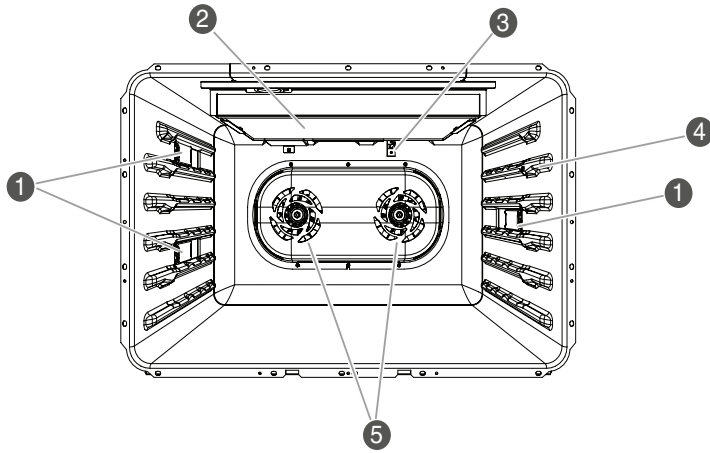

- 1 Halogen lights
- 2 Broil elements
- 3 Oven cavity sensor
- 4 Temperature probe jack
- 5 Convection fan(s)

NOTE: Some models have an 18" (45.7 cm) cavity which contains one convection fan.

CONTROL KNOBS

The oven and cooktop features are accessed through the cooktop knobs.

30" (76.2 CM)

Cooktop Knobs and Buttons

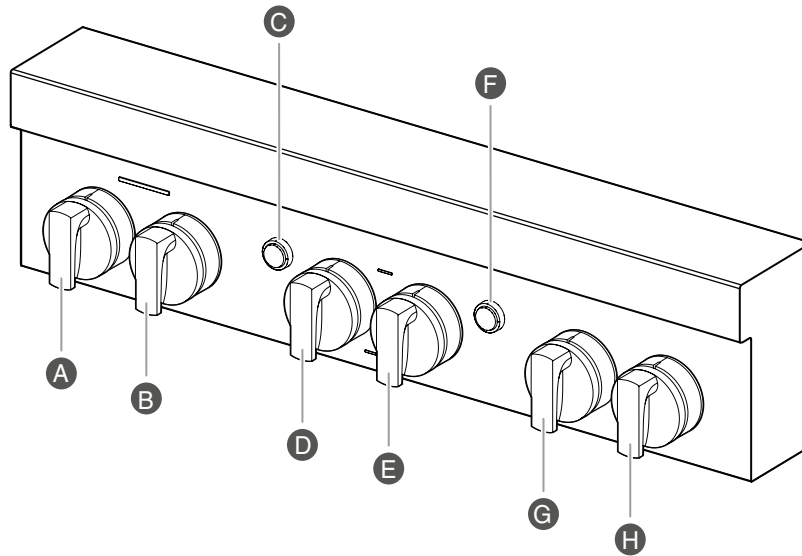

- A Left Rear Knob
- B Left Front Knob
- C Oven Light Button
- D Mode Knob
- E Temperature Knob
- F Oven Start Button
- G Right Rear Knob
- H Right Front Knob

NOTE: Cooktop configuration, features, and controls may differ.



PARTS AND FEATURES

Indicator Lights

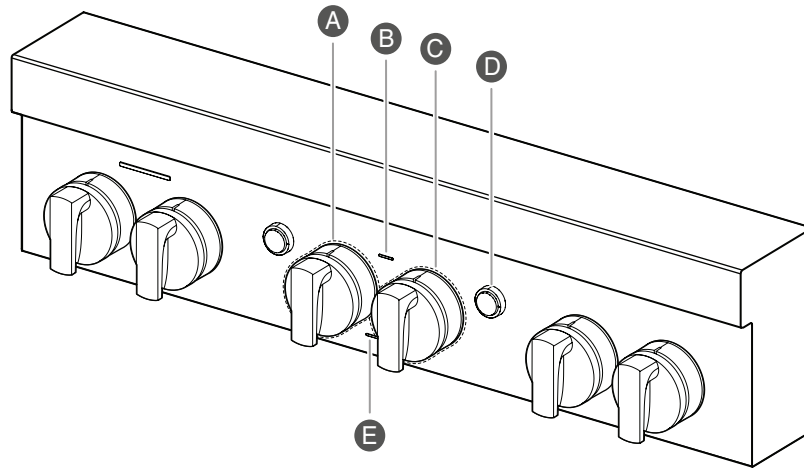

- A** Mode Knob Indicator Light
- B** Remote Indicator
- C** Temperature Knob Indicator Light
- D** Start Button Indicator Light
- E** Wi-Fi Indicator

36" (91.4 CM)

Cooktop Knobs and Buttons

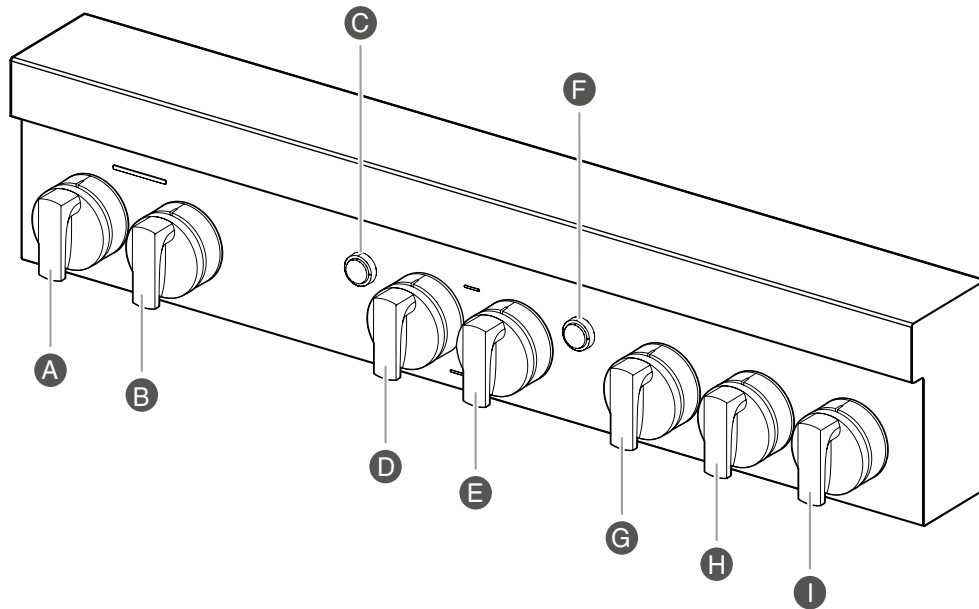

- A** Left Rear Knob
- B** Left Front Knob
- C** Oven Light Button
- D** Mode Knob
- E** Temperature Knob
- F** Oven Start Button
- G** Grill Knob
- H** Right Rear Knob
- I** Right Front Knob

NOTE: Cooktop configuration, features, and controls may differ.



Indicator Lights

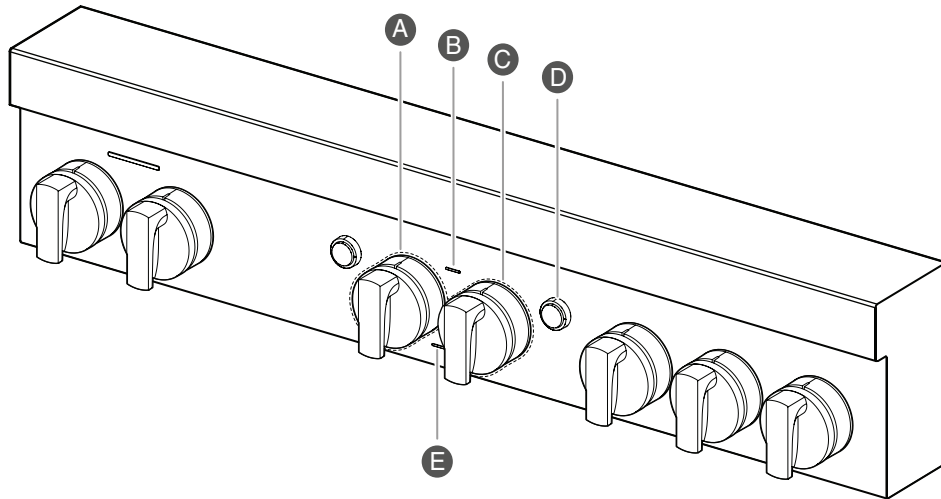

- A** Mode Knob Indicator Light
- B** Remote Indicator
- C** Temperature Knob Indicator Light
- D** Start Button Indicator Light
- E** Wi-Fi Indicator

48" (121.9 CM)

Cooktop Knobs and Buttons

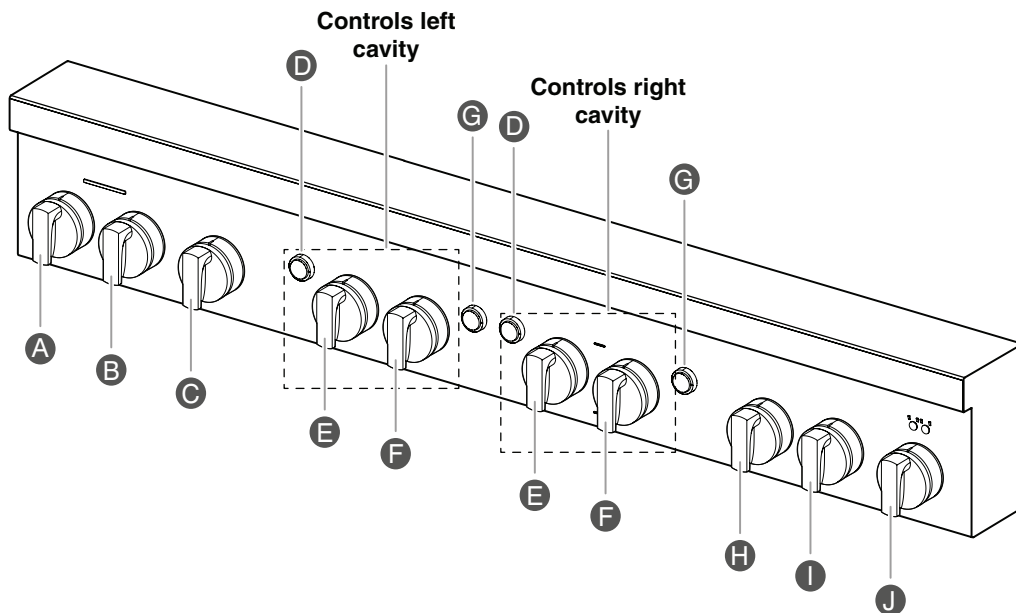

- A** Left Rear Knob
- B** Left Front Knob
- C** Grill Knob
- D** Oven Light Button
- E** Mode Knob
- F** Temperature Knob
- G** Oven Start Button
- H** Center Rear Knob
- I** Center Front Knob
- J** Griddle Knob

NOTE: Cooktop configuration, features, and controls may differ.



PARTS AND FEATURES

Indicator Lights

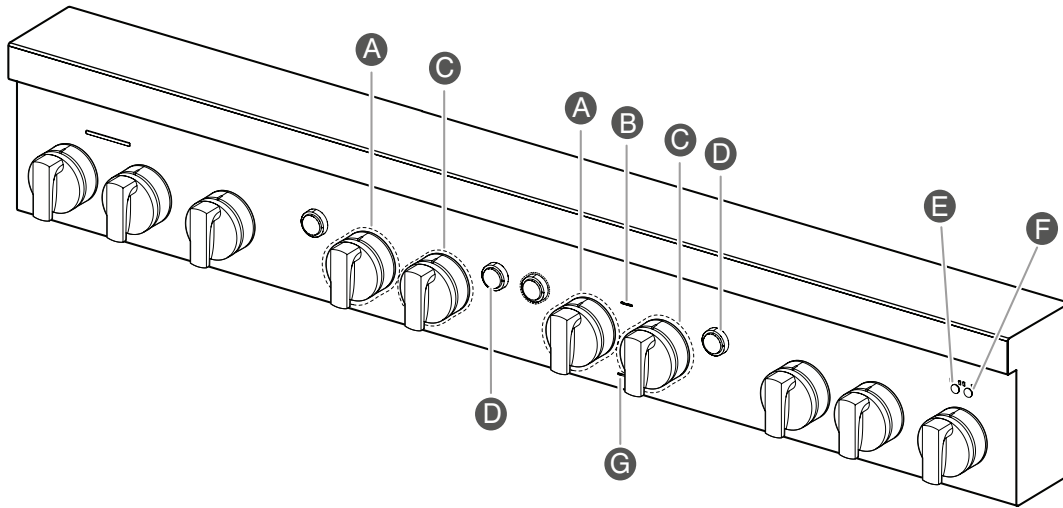

- A** Mode Knob Indicator Light
- B** Remote Indicator
- C** Temperature Knob Indicator Light
- D** Start Button Indicator Light
- E** Griddle Preheat Light
- F** Griddle Cooktop ON Light
- G** Wi-Fi Indicator

FEATURE	DESCRIPTION/BEHAVIOR	INSTRUCTIONS
Mode Knob	<p>Non-Steam Models</p> <ul style="list-style-type: none"> ■ BAKE ■ CONVECT BAKE ■ CONVECT ROAST ■ CONVECT BROIL ■ BROIL ■ Wi-Fi ■ CLEAN <p>Steam Models</p> <ul style="list-style-type: none"> ■ BAKE ■ CONVECT ■ STEAM BREAD ■ STEAM MEATS ■ BROIL ■ Wi-Fi ■ CLEAN 	<p>Turn the knob to select the desired cooking mode.</p> <p>NOTE: When the unit is on, mode can be changed between Bake, Convection Bake, Convection Roast, and Broil/Convection Broil. Press the Start button to confirm mode change.</p>

PARTS AND FEATURES



FEATURE	DESCRIPTION/BEHAVIOR	INSTRUCTIONS
Mode Knob Indicator Light	<p>When a cooking mode is selected, and the Temperature Knob is in a valid position, the Temperature and Mode indicator lights will light white.</p> <p>When the Start button has been pressed, the knob indicator lights will turn white and pulse until preheat has completed. The light will turn solid white and a tone will sound when preheat is complete.</p> <p>If there is no preheat for a cycle, the preheat completes immediately and the light turns solid white.</p> <p>NOTE: If an invalid mode and temperature combination have been selected, the knob lights will blink and a tone will sound prompting the user to select a valid combination. The indicator light will continue to blink and a tone will sound every 30 seconds until the error is fixed or timeout after 2 minutes of inactivity.</p>	
Temperature Knob	<ul style="list-style-type: none"> ■ OFF ■ PROOF ■ KEEP WARM <p><Temperature Range></p> <ul style="list-style-type: none"> ■ BROIL LOW ■ BROIL HIGH ■ Wi-Fi ■ CLEAN 	Turn the knob to select the desired cooking temperature or setting.
Temperature Knob Indicator Light	<p>When a temperature or setting is selected, and the mode is valid, the Temperature and Mode indicator lights will light white.</p> <p>When the Start button has been pressed, the knob indicator light will turn white and pulse until preheat has completed. The light will turn solid white and a tone will sound when preheat is complete.</p> <p>If there is no preheat for a cycle, the preheat completes immediately and the light turns solid white.</p> <p>NOTE: If an invalid mode and temperature combination has been selected, the knob light will blink and a tone will sound prompting the user to select a valid combination. The indicator light will continue to blink and a tone will sound every 30 seconds until the error is fixed or time-out after 2 minutes of inactivity.</p> <p>The temperature knob will blink amber if the oven is too hot to proof or if a 100+ degree decrease in temperature is in progress i.e. changing from Bake 450°F to Bake 350°F (177°C to 232°C).</p>	
Start Button	Start an oven function once a valid mode and temperature have been selected.	<p>HOW TO START OVEN</p> <ol style="list-style-type: none"> Set mode and temperature knobs to desired selection. NOTE: The Start button will blink white when ready. Press the Start button to begin cycle.
Start Button Indicator Light	The Start button indicator light will flash white to prompt the user to press the Start button.	NOTE: When the unit is on, mode can be changed between Bake, Convection Bake, Convection Roast, and Broil/Convection Broil. Press the Start button to confirm mode change.



PARTS AND FEATURES

FEATURE	DESCRIPTION/BEHAVIOR	INSTRUCTIONS
Oven Light Button	Turn the oven light on and off.	Press the Oven Light button to toggle the light on and off. The button turns the light on and off regardless of whether the door is open.
Wi-Fi Indicator Light	The Wi-Fi indicator light illuminates white when the unit is Wi-Fi enabled.	All lights will turn off in Idle mode.
Remote Indicator Light	The Remote indicator light illuminates white when the unit is remote enabled.	All lights will turn off in Idle mode.
Griddle Cooktop ON Light	Right Griddle indicator light - The Griddle Cooktop On light illuminates blue when the griddle knob is powered on.	
Griddle Preheat Light	Left Griddle indicator light - The griddle Preheat light flashes blue while the griddle is preheating. Once preheat temperature has been reached, the indicator light turns solid blue.	



BURNERS

⚠ WARNING



Fire Hazard

Do not let the burner flame extend beyond the edge of the pan.

Turn off all controls when not cooking.

Failure to follow these instructions can result in death or fire.

- Check that the burner knob is pressed completely down on the valve shaft. If the spark igniter still does not operate, call a trained repair specialist.
- When the burner knob for the desired burner is turned to the IGNITE position, the burner will click independent of the other burners.

REMEMBER: When range is in use or during the Self-Cleaning cycle, the entire cooktop area may become hot.

Flame-Sensing™ Reignition Feature

During cooktop use, if one or more burners are extinguished due to external causes (such as a water spill, wind, or ventilation draft), the ignition system will turn on to reignite the flame. When the flame comes back on, the system will stop sparking. If the draft in the room is not removed, occasional sparking may continue. Sparking may also occasionally occur when using the low setting on a burner.

To Set a Burner:

<p>1. Push in and turn counterclockwise</p> <p>to IGNITE.</p>	<p>2. Turn knob counterclockwise</p> <p>between Hi and Lo.</p>
--	---

Turn knob counterclockwise further for Simmer Hi and Simmer Lo.

In Case of Power Failure

Hold a lit match near a burner and turn knob counterclockwise to Hi. After burner lights, turn knob to desired setting.

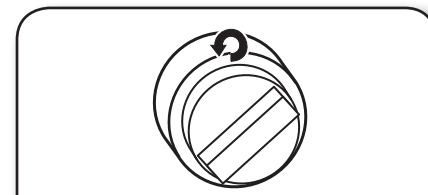
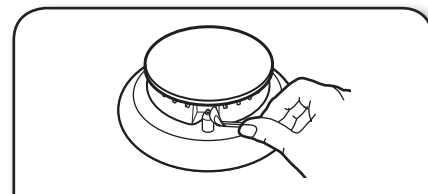

BTU/hr	BURNER APPEARANCE	FEATURES
Large stacked burner		This burner has an upper and lower level of flame. The Hi setting uses both flame levels at full power to provide the highest heat. It is ideal for cooking large quantities of food or liquid and using large pots and pans. The Simmer Hi and Lo settings use the lower flame only.
Small burner		This burner is ideal for cooking smaller quantities of food and melting chocolate or butter.

Igniting Burners:

- Electric igniters automatically light the surface burners when burner knobs are turned to IGNITE.
- Before setting a burner knob, place filled cookware on the grate. Do not operate a burner using empty cookware or without any cookware on the grate.
- Visually check that the burner has lit. If the burner does not ignite, listen for the clicking sound. If you do not hear the igniter click, turn off the burner. Check for a tripped circuit breaker or blown fuse.



COOKTOP FEATURES

SEALED SURFACE BURNERS

Sealed surface burners are designed to minimize gaps and seams that can allow liquids and spills to get under the cooktop. This design makes cleanup quick and easy.

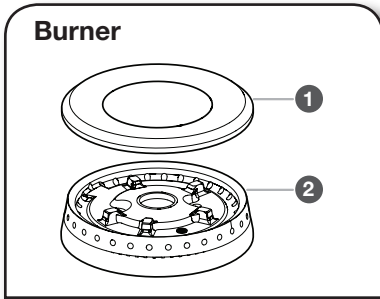

- 1 Burner cap
- 2 Burner base

IMPORTANT: Do not obstruct the flow of combustion and ventilation air around the burner grate edges.

Burner cap: Always keep the burner cap in place when using a surface burner. A clean burner cap will help avoid poor ignition and uneven flames. Always clean the burner cap after a spillover, and routinely remove and clean the caps according to the "Care and Cleaning" section.

Gas opening: Gas must flow freely throughout the gas opening for the burner to light properly. Keep this area free of soil and do not allow spills, food, cleaning agents, or any other material to enter the gas opening. Keep spillovers out of the gas opening by always using a burner cap.

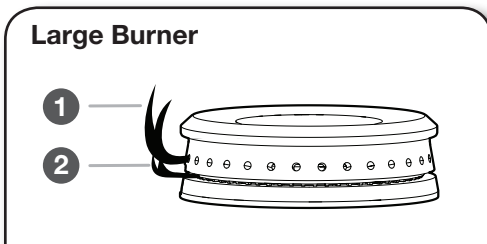

- 1 Upper (main) flame
- 2 Lower (simmer) flame

Burner Ports:

Check burner flames occasionally for proper size and shape as shown above. A good flame is blue in color, not yellow. Keep this area free of soil and do not allow spills, food, cleaning agents, or any other material to enter the burner ports.

GRILL (on some models)

The grill module consists of a cast-iron grate, a burner assembly, deflector and a drip tray.

NOTE: The burner assembly is not removable and should not be removed except by a qualified service technician.

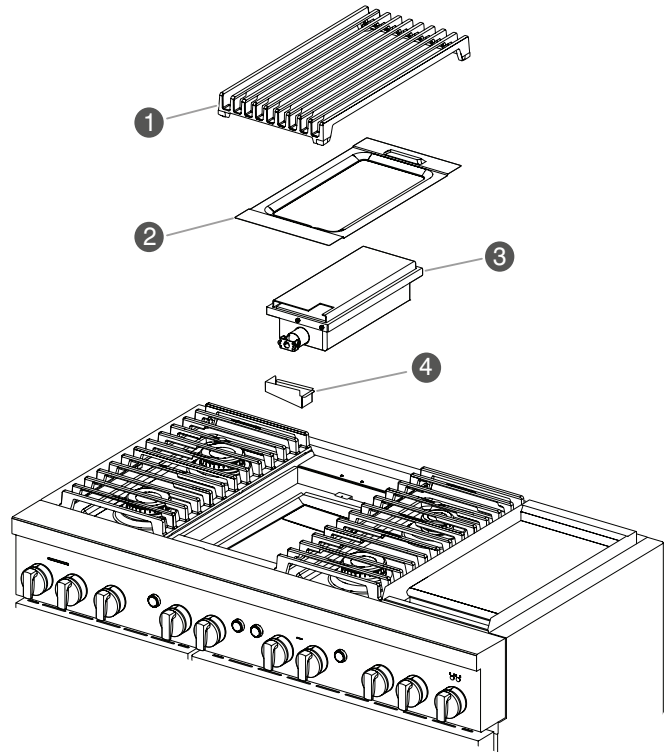



- 1 Grate
- 2 Deflector
- 3 Burner assembly
- 4 Drip tray

When using the grill, follow the guidelines below:



- Trim excess fat to reduce spattering. Slit the remaining fat on the edges to avoid curling.
- Allow space between food on the grill. Crowding food will result in uneven cooking.
- For most even results, center foods on the grate directly over the heat source.
- Use a metal spatula or tongs to turn food.
- For even cooking, foods such as chicken quarters should be turned several times.
- To check for doneness of meats and poultry, use an instant read thermometer or make a small cut in the center of the food.
- Do not leave the grill unattended while cooking.
- To avoid damage to the grill, do not use aluminum foil, charcoal or wood chips.
- To avoid damage to cookware, do not place cookware on the grill when in use. Food should be cooked directly on the grill grate.

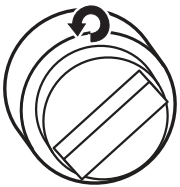

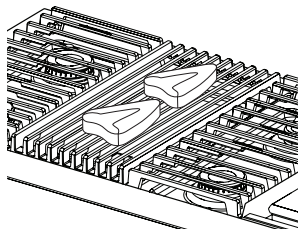
To Use:

<p>1. Turn on overhead range hood.</p>	<p>3. Turn knob to ON</p>  <p>and allow grill to preheat.</p>
<p>2. Push in and turn knob</p>  <p>to IGNITE. The flame will ignite in 1-4 seconds.</p>	<p>4. Place food on grill.</p> 

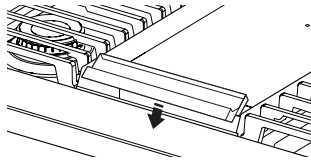
To Use:

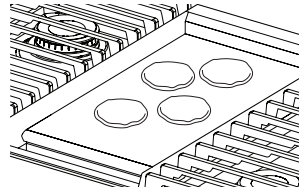
<p>1. Position drip tray.</p> 	<p>3. Wait for preheat light to solid indicating the griddle has reached preheat.</p>
<p>2. Push in and turn knob</p>  <p>to desired temperature.</p>	<p>4. Place food on the griddle</p>  <p>and cook to desired doneness.</p>

CHROME ELECTRIC GRIDDLE (on some models)

The chrome electric griddle provides the perfect cooking surface for grilled sandwiches, pancakes, eggs, burgers, sautéed vegetables, and many more family favorites. The attractive low-stick surface is designed to make cleanup easy.

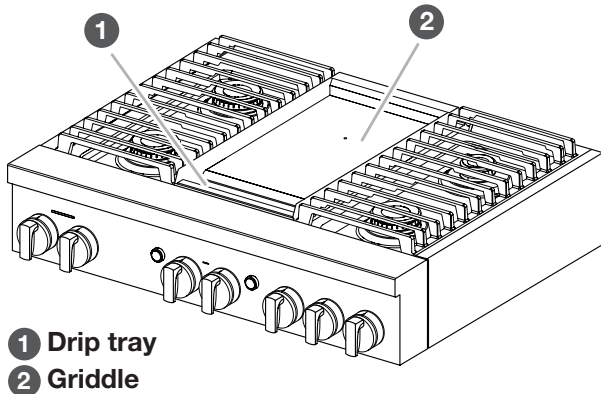

- 1** Drip tray
- 2** Griddle

The chrome electric griddle system provides a convenient cooking surface.

- Be sure plastic film has been removed and wash with hot water before first use.
- To avoid scratching the griddle, do not place any pots or pans on the griddle. Use only heat-resistant plastic or wooden utensils.
- The griddle surface is ready to use and does not need to be seasoned.
- Pouring cold water on a hot griddle may warp the griddle, resulting in an uneven cooking surface.

The left griddle indicator light shows that there is power applied to the griddle.

The right griddle indicator light blinks to show that the griddle is preheating. When preheat is complete, the right griddle indicator lights solid.

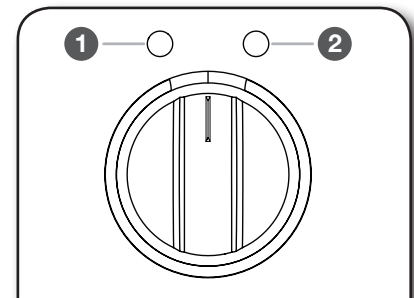

- 1** Griddle Preheat Light
- 2** Griddle Cooktop ON Light

Cooking Chart

The settings and times are guidelines only and may need to be adjusted for individual tastes.

FOOD ITEM	TEMPERATURE	COOK TIME (IN MINUTES)
Toast/Pancakes	350°F (175°C)	4-10
Eggs	250°F (120°C)	7-10
Meats	350°F (175°C)	10-20
Potatoes	350-450°F (175-230°C)	10-20
Fish	250-350°F (120-175°C)	8-15



USING YOUR OVEN

OVEN CONTROL KNOBS

To Use:

1. Select desired function on the Mode Knob.
2. Select desired temperature on the Temperature Knob.
3. To turn off the unit, the temperature knob needs to be turned to OFF.

Knob Combinations

The following table shows valid and invalid knob combinations for the temperature and mode knobs.

MODE KNOB	TEMPERATURE KNOB						
	PROOF	KEEP WARM	TEMP RANGE	BROIL LOW	BROIL HIGH	CLEAN	Wi-Fi
Bake	Valid	Valid	Valid (225-500°F)	Invalid	Invalid	Invalid	Invalid
Convect Bake	Invalid	Invalid	Valid (225-500°F)	Invalid	Invalid	Invalid	Invalid
Convect Roast	Invalid	Invalid	Valid (225-500°F)	Invalid	Invalid	Invalid	Invalid
Steam Bread/Meats	Invalid	Invalid	Valid (250-450°F)	Invalid	Invalid	Invalid	Invalid
Broil/Convect Broil	Invalid	Invalid	Invalid	Valid	Valid	Invalid	Invalid
Self Clean	Invalid	Invalid	Invalid	Invalid	Invalid	Valid	Invalid
Wi-Fi	Invalid	Invalid	Invalid	Invalid	Invalid	Invalid	Valid

NOTE: When the unit is on, mode can be changed between Bake, Convect Bake, Convect Roast, and Broil/Convect Broil. Press the Start button to confirm mode change.

INDICATOR LIGHTS

The indicator lights illuminate and blink to show the status of the unit.

BEHAVIOR	DESCRIPTION/EXAMPLES	EXAMPLES
Light Pulsing/Blinking	Light pulsing is used on the Mode Knob, Temperature Knob, and the Start button as a way to prompt for action. When an action is prompted to be completed, the associated indicator light feature will blink. Examples: Occurrence: Prompt for action, press the Start button Result: Start button indicator light quickly blinks Occurrence: 100°F (38°C) decrease in temperature required or oven too hot for Proof Result: Knob indicator lights will slowly blink until the oven is at the correct proof temperature	There are two types of pulsing: 1. Start Button Quick Blink: prompting for action. 2. Mode/Temperature Knob White slow blink: preheating Amber slow blink: unit is above target temperature. When a cycle requiring preheat starts, slow blink will begin. When preheat temperature has been reached, the blinking will stop and the mode/temp indicator lights will be solid.
Mode and Temperature Knob Indicator - Slow Blink	The Mode and Temperature knob indicators will slowly blink to indicate that the feature is in use.	A slow blink indicates that a feature is being used and no further action is required i.e. unit is preheating. HOW TO START OVEN 1. Set mode and temperature knobs to desired selection. NOTE: The Start button will blink white when ready. 2. Press the Start button to begin cycle.

USING YOUR OVEN



BEHAVIOR	DESCRIPTION/EXAMPLES	EXAMPLES
START Button - Invalid Selection (Quick Blink)	If an invalid knob combination has been chosen and the Start Button is pressed, the Start Button Indicator Light will quickly blink and a tone will sound to indicate that the chosen selection is invalid. See "Knob Combinations" table for examples.	Bake on the Mode Knob and Wi-Fi on the Temperature Knob. HOW TO START OVEN 1. Set mode and temperature knobs to desired selection. NOTE: The Start button will blink white when ready. 2. Press the Start button to begin cycle.
Temperature/Mode Knob - Invalid Selection (Quick Blink)	If an invalid knob combination has been chosen, the Mode Knob Indicator Light and Temperature Knob Indicator Light will quickly blink white. The indicator light will continue to quickly blink and a tone will sound every 30 seconds until the error is fixed or timeout after 2 minutes of inactivity. See "Knob Combinations" table for examples.	Bake on the Mode Knob and Wi-Fi on the Temperature Knob. HOW TO START OVEN 1. Set mode and temperature knobs to desired selection. NOTE: The Start button will blink white when ready. 2. Press the Start button to begin cycle.
Prompt for Action - Inactivity (Quick Blink)	When a valid knob combination has been made, the Start button indicator light will quickly blink to prompt for the Start button to be pressed. If no action is taken after 2 minutes, a tone will sound and the unit will timeout and return to idle mode. To exit the unit from idle mode, reselect a Mode and Temperature Knob selection before pressing the Start button.	A quick blink indicates that a valid combination has been selected and is prompting for an action to be taken i.e. Mode is in Bake and temperature is at 350°F (177°C), but the Start button has not been pressed yet.
Validity Check Delay	The unit goes through a validity check to verify that the selected Mode and Temperature combination is valid. If a valid combination has been selected, the Mode/Temperature Knob indicator lights will show white and the Start button will begin to blink prompting for action. If an invalid combination has been selected, the knob indicator lights will blink to show that the selected Mode and Temperature combination is invalid.	Refer to "Knob Combinations" section for more information. If the Start Button is pressed too quickly in the validity check, the Start Button indicator light will display an invalid quick blink.
Invalid Temperature Selection Made During A Cycle	If the Temperature Knob is changed during a cycle to a selection that is invalid and the unit was in a previous cycle, the unit will remain in the previous cycle until corrected. The knob indicator lights will blink to show an invalid selection has been made and will continue to light until corrected.	Mode is in bake, temp is at 350°F (177°C), the Start button is pressed and cycle is running. Then temp is moved to clean. Unit will continue to bake at 350°F (177°C).
Changing Mode Selections During A Cycle	If the Mode Knob is changed during a cycle to a selection that is valid, the Start button will blink to indicate prompt for action. Press the Start Button to begin new Mode selection.	If the Mode Knob is moved from Bake to Convection Bake, the Start button will blink as a prompt for action.
Changing Temperature Selections During A Cycle	If the Temperature Knob is changed during a cycle to a selection that is valid, the temperature will automatically change.	If the temp during a Bake cycle is moved from 350°F to 450°F (177°C to 232°C), the unit will bake at 450°F (232°C).

A tone will sound when:

- the unit is powered on
- the unit switches to Off mode
- a valid Mode and Temperature selection has been made and the Start button is pressed to begin a cycle
- an invalid Start button selection is made
- there is an error with the unit
- preheating has been completed
- the timer from the app has ended (the tone will sound every five minutes until the timer is stopped)
- a Wi-Fi event is occurring
- the Meat probe connects/disconnects



USING YOUR OVEN

Sabbath Mode

- Sabbath Mode is used to configure the oven system so that certain features and modes are disabled or deactivated.
- The Sabbath Mode sets the oven to remain ON in a bake setting until turned off.
- When a button is pressed, no tones will sound.
- All alerts and tones are disabled during Sabbath Mode. All lights stay in the mode of when Sabbath Mode was enabled. For example, if the oven light was on when the user enabled Sabbath Mode, the light would remain on during the entire Sabbath Mode period.
- When the oven door is opened or closed, the oven light will not turn on or off and the heating elements will not turn on or off immediately.
- If a power failure occurs when the Sabbath Mode is set, the oven will remain in Sabbath Mode but will no longer be actively cooking.
- The Sabbath Mode must be entered each time it is used.
- Sabbath Mode disables the 12-hour shutoff. All lights and displays are disabled so that no visible activity takes place when the oven door is opened.

To Enter Sabbath Mode:

- Turn the Mode knob(s) to the Bake position. The Temperature knob(s) stays in the OFF position.
NOTE: Valid only in the Bake mode position.
- Press the Start button seven times within ten seconds.
NOTE: If there are double ovens, both ovens will enter into Sabbath Mode.
- The Start button for both ovens will light until Sabbath Mode is exited.

Using Sabbath Bake Mode:

- Bake mode is the only mode valid for Sabbath Mode. Select the desired temperature for each available oven and press the Start button.
NOTE: The temperature can be changed while in Sabbath Mode.
- If Sabbath Bake mode is disabled in one oven, the other oven will still remain Sabbath enabled.
- Once an oven has been disabled by turning the temperature knob to OFF, it cannot be turned back on.
NOTE: Before utilizing Sabbath Mode after successfully connecting to Wi-Fi, verify the app is turned off.

To Exit Sabbath Mode:

- Turn either Temperature knob to the OFF position. The Mode knob stays in the BAKE position.
- Press the Start button seven times within ten seconds. Within a few seconds, the Start light indicators will turn off.
- If you exit Sabbath Mode in one oven, the other oven will also exit Sabbath Mode.

Wi-Fi Connectivity and Remote Operation

Models are provided with a Wi-Fi module that allows the unit to be remotely operated. The control is capable of monitoring and performing the following remote operations once the remote enabling function sequence is properly initiated at the appliance. See the "Remote Enable" section for more information.

Press the Start button once your appliance is Remote Enabled.

Download the App

The first step to get your appliance connected is to download the app on your mobile device. The app will be your guide and walk you through all of the steps. Download the app by visiting iTunes® or Google Play®.

To connect your appliance:

1. Download the JennAir® app from Google Play® or iTunes®.
2. Follow the prompts in the app to create an account.

Add Appliance

1. Turn the Mode Knob and Temperature Knob to the Wi-Fi position.
2. Look for the SAID code on your appliance. The SAID can be scanned or manually added.

NOTE: The SAID label is located on the lower right of the front side panel.

3. Follow the prompts in the app.

Remote Enable

Once the appliance is connected, use the Remote Enable feature to control features of the appliance from the app such as:

- Access the oven from any mobile device
- Set and preheat the oven from any location
- Monitor progress of cooking cycle
- Adjust cook time and temperature

A cooking cycle does not stop when the oven door is opened. Remote enable will stay enabled.

NOTE: The app overrides any knob selections that have been made while Remote Enable is enabled. If the Mode and Temperature Knobs are set and the appliance is remote enabled, the app will control the oven functions.

Reference the "Internet Connectivity Guide" for more information.

App Features

The JennAir® app puts complete control of your Connected Appliance at your fingertips.

- Access JennAir® Culinary Center
- Access JennAir® Steam and Specialty Cycles
- JennAir® works with Nest®
- Adjust cooking temperatures and times



Preheat, check cooking status, and configure oven features remotely by using the JennAir® app, available for either iOS or Android® devices.

The JennAir® app synchronizes with Nest, and can adjust the kitchen temperature when the oven is on. Also, since Nest can detect when you are home, the app will send alerts if you forget to turn the oven off while you're away.

JennAir and Nest Thermostat

Maintain a comfortable environment. If the oven temperature rises above a certain level set by the user, the thermostat will lower its temperature setting by an amount predetermined by the user.

Home/Away Assist & JennAir

Automatically alert users of oven activity when the home is set "Away." If the oven is active when the home is set "Away," the app will alert the user and give the option to turn the oven off.

†Nest® and Nest Learning Thermostat® are trademarks licensed by Nest Labs, Inc.
‡Google Play® and Android® are registered trademarks of Google Inc.
§iTunes® is a registered trademark of Apple Inc.



OVEN USE

Odors and smoke are normal when the oven is used the first few times, or when it is heavily soiled.

During oven use, the heating elements will not remain on, but will cycle on and off throughout oven operation.

IMPORTANT: The health of some birds is extremely sensitive to the fumes given off. Exposure to the fumes may result in death to certain birds. Always move birds to another closed and well-ventilated room.

Aluminum Foil

IMPORTANT: To avoid permanent damage to the oven bottom finish, do not line the oven bottom with any type of foil or liner.

- For best cooking results, do not cover rack with foil because air must be able to move freely.
- To catch spills, place foil on rack below dish. Make sure foil is at least 1/2" (1.3 cm) larger than the dish and that it is turned up at the edges.

Positioning Racks and Bakeware

IMPORTANT: To avoid permanent damage to the porcelain finish, do not place food or bakeware directly on the oven door or bottom.

Racks

- Position racks before turning on the oven.
- Do not position racks with bakeware on them.
- Make sure racks are level.
- When installing racks in adjacent rack levels, begin by installing the lower rack first.

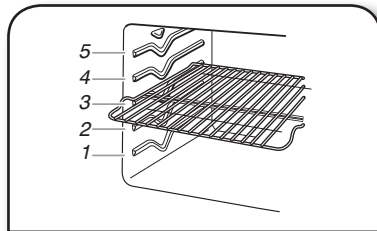

Bakeware

To cook foods evenly, center the dish under the broil element and allow 2" (5.0 cm) of space around pan and the oven wall to ensure adequate air circulation.

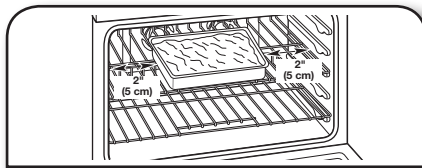

Roll-Out Rack

The roll-out rack allows easy access to position and remove food in the oven. The roll-out rack will fit in all positions.

Open Position

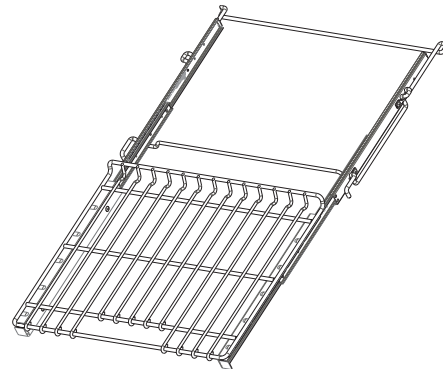

Closed and Engaged Position

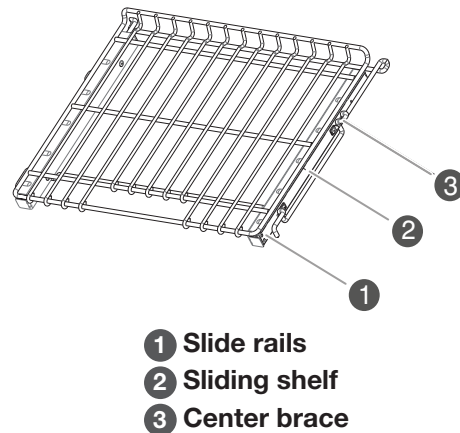

- 1 Slide rails
- 2 Sliding shelf
- 3 Center brace

To Insert Roll-Out Rack

1. Angle the rack assembly up and insert the back edge into the "V" cutout in the rack guides of the oven cavity.
2. Keep the rack lifted at an angle and push in until the back edge of the sliding rails (A) bypass the lower "V" cutout.
3. Angle the rack downward and continue to gently slide the assembly in until the center brace (C) bypasses the "V" cutout.
4. Raise rack assembly to flat position and gently push to the back of the oven until the back edge of the sliding rail drops.
5. When placing racks in adjacent positions, start by loading the lower rack positions first and then install the rack in the position above it.



USING YOUR OVEN

6. Pull the rack assembly slightly forward until the front edge drops and the sliding rails are on the rack guide.

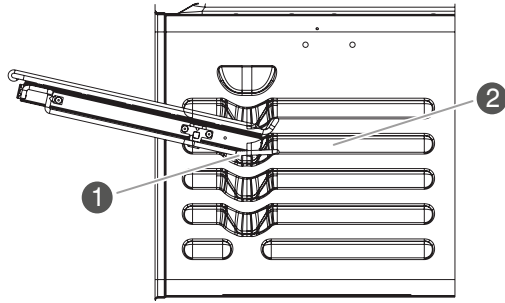

- 1 "V" cutout
- 2 Rack guide

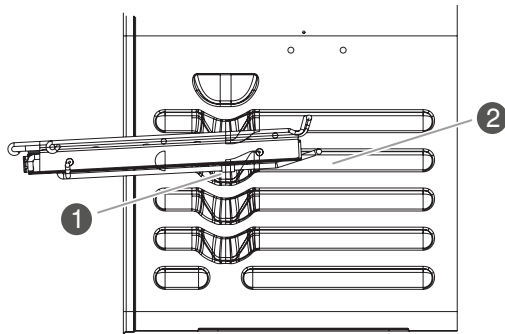

- 1 "V" cutout
- 2 Rack guide

To Remove Roll-Out Rack

1. Push the sliding shelf in completely so that it is closed and engaged with the slide rails.

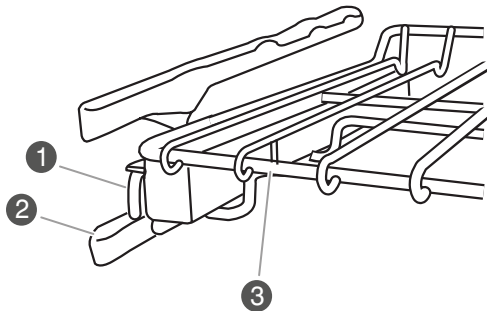

- 1 Sliding shelf
- 2 Slide rails
- 3 Rack

2. Using 2 hands, lift up on the front edge of the rack assembly. Slowly push the rack assembly to the back wall of the oven so the front edge of the sliding shelf sits on the rack guides on the side of the oven cavity. The front edge of the rack should be higher than the back edge.
3. Using 2 hands, lift up the back of the rack assembly so that the front and back are level on the rack guides.
4. Pull the rack assembly out.

To avoid damage to the sliding shelves, do not place more than 25 lbs (11.4 kg) on the rack.

Do not clean the roll-out rack in a dishwasher. It may remove the rack's lubricant and affect its ability to slide.

See the "General Cleaning" section for more information.

When placing racks in adjacent positions, start by loading the lower rack positions first and then installing the rack in the position immediately above it.

Oven Vent

The oven vent should not be blocked or covered since it allows the release of hot air and moisture from the oven. Blocking or covering the vent will cause poor air circulation, affecting cooking and cleaning results. Do not set plastics, paper, or other items that could melt or burn near the oven vent.

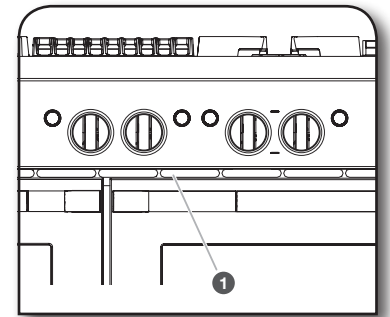

- 1 Oven vent

Cooling Fan

The oven has a dual speed cooling fan motor.

When the oven temperature is in the Self-Cleaning cycle, the fan will operate at its highest speed to increase airflow and better exhaust the hotter air through the oven vent(s). An increase in noise may be noticeable until the oven cools.

NOTE: Cooling fan may continue to run after the oven has been turned off.



COOKING MODES

(BAKE, CONVECT BAKE, CONVECT ROAST, CONVECT BROIL, AND BROIL)

Choose an Oven Function

1. Choose an oven function by turning the Mode Knob and Temperature Knob to desired selections.
NOTE: The Start button will flash white to prompt the user to press the Start button.
2. Press the Start button to begin oven function.

When a knob selection is made, and after some time of inactivity, the Start Button Indicator Light will quickly blink to prompt for the Start button to be pressed.

If no action is taken after 2 minutes, a tone will sound and the unit will timeout and return to idle mode.

To exit the unit from idle mode, reselect a mode and Temperature Knob selection before pressing the Start button.

NOTE: The unit goes through a validity check to verify that the selected mode and temperature combination is valid.

If a valid combination has been selected, the knob light and the Start button indicator light will be on. The Start button will begin to blink prompting for action.

If an invalid combination has been selected, the knob indicator lights will blink to show that the selected mode and temperature combination is invalid and a invalid tone will sound.

Changing a Mode, Temperature, while Oven is Active

If the Mode Knob is changed during a cycle to a selection that is valid, the Start button will blink and must be pressed in order to change the mode.

NOTE: The unit will not change modes until the Start button has been pressed.

If the Temperature Knob is changed during a cycle to a selection that is valid, the temperature will automatically change.

If the Mode/Temperature Knob is changed during a cycle to a selection that is invalid and the unit was in a previous cycle, the unit will remain in the previous cycle until corrected.

The knob indicator lights will illuminate to show an invalid selection has been made and will continue to light until corrected.

To Turn Off Oven:

Turn the Temperature Knob to the OFF position.

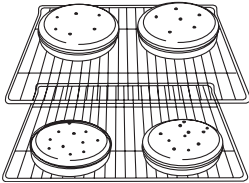
BAKED GOODS	RECOMMENDED MODE(S)	RECOMMENDED RACK POSITION(S)	TIPS
Cakes	Bake	Two racks — 2 and 4 One rack — 3	 <p>For best results when baking cakes on 2 racks, place the cakes on the racks as shown.</p>
Cookies	Convect Bake	Three racks — 1, 3, and 5 Two racks — 2 and 4 One rack — 3	
Casseroles	Bake	One rack — 2	
Chicken (whole)	Convect Roast	One rack — 2	
Frozen Foods/Pizza	Bake	One rack — 2	
Meats (thinner cuts and pieces)*	Broil	One rack — 4	
Meats (thicker cuts and whole poultry)	Broil	One rack — 3	
Turkey (whole)	Bake	One rack — 1	

*For hamburger patties to have a well-seared exterior and a rare interior, preheat the broiler for 5 minutes and place the rack in position 4. Side 1 should cook for approximately 2-3 minutes. Side 2 should cook for approximately 4-5 minutes. Expect a moderate degree of smoke when broiling.



USING YOUR OVEN

BAKE

The Bake mode relies primarily on heat from the lower bake element and radiant heat from the oven cavity to produce the perfect conditions for cakes, cookies, quick breads, yeast breads, meatloaf, and baked desserts. This mode is perfect for foods that require both upper and lower browning.

Know Your Bake Mode

- During baking, the appropriate heating elements and fan(s) will cycle on and off in intervals to maintain the oven temperature.
- Bake is used to cook up to 2 racks of food.
- For best results, allow the oven to preheat prior to placing food in the oven.
- If the oven door is opened during baking, the bake burner will turn off approximately 30 seconds after the door is opened. It will turn on again approximately 30 seconds after the door is closed.

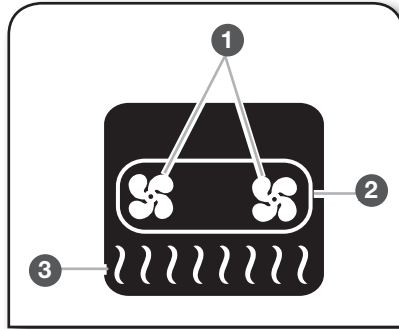

- 1 Convection fan
- 2 Convection element
- 3 Bake element

- For best results, use a broiler pan and grid. It is designed to drain juices and help avoid spatter and smoke.
- For proper draining, do not cover the grid with foil. The bottom of the broiler pan may be lined with aluminum foil for easier cleaning.
- Trim excess fat to reduce spattering. Slit the remaining fat on the edges to avoid curling.
- When broiling, changing the temperature allows more precise control. Lowering the temperature causes food to cook slower. Thicker cuts and unevenly shaped pieces of meat, fish, and poultry may cook better at lower broiling temperatures.
- Pull out oven rack to stop position before turning or removing food. Use tongs to turn food to avoid the loss of juices. Very thin cuts of fish, poultry, or meat may not need to be turned.
- After broiling, remove the pan of food from the oven. Drippings will bake on the pan if left in the heated oven, making cleaning more difficult.

To Use Broil:

For best results, preheat oven for 5 minutes. Position food on the grid on the broiler pan, then place pan in the center of the oven rack and center your pan under the broil element.

CONVECT BROIL

During convection broiling, the element will cycle on and off in intervals to maintain oven temperature, while the fans circulate the hot air. Cooking times will vary with the rack location and temperature selected. The elements and fan turn off immediately if the door is opened and turn on again immediately when the door is closed.

Know Your Convection Broil Mode

- For best results, preheat oven for 5 minutes before inserting food.
- See Broil mode for tips and recommendations.

Keep Warm™ Option

The Keep Warm™ option allows hot cooked foods to stay at serving temperature. It can also be used at the end of a timed cook.

BROIL

The Broil mode uses intense heat from above to cook foods quickly and is ideal when you want rich, flavorful browning of exterior surfaces. Use for steak, chicken, pork, fish, or vegetables like onions and peppers. This mode can also brown and crisp desserts or casserole toppings.

Know Your Broil Mode

- Broiling uses direct radiant heat to cook food.
- The broil burner cycles on and off in intervals to maintain the oven temperature.
- If the oven door is opened during broiling, the broil element will turn off in approximately 30 seconds. When the oven door is closed, the elements will come back on approximately 30 seconds after the door is closed.

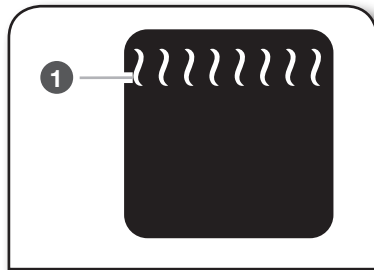

- 1 Broil

⚠ WARNING

Food Poisoning Hazard

Do not let food sit in oven more than one hour before or after cooking.

Doing so can result in food poisoning or sickness.

IMPORTANT: Food must be at serving temperature before placing it in the warmed oven. Food may be held up to 1 hour; however, it is recommended that foods be covered with aluminum foil to help retain moisture and avoid becoming dry during holding.

To Use Keep Warm

1. Turn the Mode Knob to the Bake position.
2. Turn the Temperature Knob to the Warm position.
3. Press the Start button.

NOTE: Keep Warm defaults to 170°F (77°C).



CONVECTION COOKING

Convection cooking can cook foods more evenly and faster than regular cooking. The convection elements are located in the rear of the oven cavity. They are assisted by the convection fans to provide balanced, efficient heating.

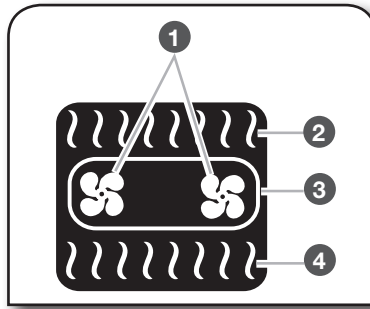

- 1 Convection fans
- 2 Broil element
- 3 Convection element
- 4 Bake element

CONVECT BAKE

The Convection Bake mode uses multiple elements and a fan to circulate hot air throughout the oven, resulting in baking 10–20% faster than traditional baking.

Know Your Convection Bake Mode

- When cooking an oven meal with several different types of foods, be sure to select recipes that require similar temperatures. Cookware should sit in the oven with at least 2" (5.1 cm) of space between the cookware and the sides of the oven.
- If the oven door is opened during convection baking, the fans turn off immediately when the door is opened and turn on immediately when the door is closed. Convection, bake, and broil elements will turn off approximately 30 seconds after the door is opened. They will turn on again approximately 30 seconds after the door is closed.
- Check food at shortest recommended package or recipe time. Allow more time for baking when using multiple racks.
- Use cookie sheets with no sides to allow air to move freely around the food.

AUTO CONVECT CONVERSION

Convection modes use additional elements and fans to distribute temperatures evenly throughout the cavity. As a result, baking temperatures and/or times may differ from traditional recipes and packaged goods instructions. Auto Convection Conversion automatically reduces the standard recipe time and temperature for convection cooking.

CONVECT ROAST

Convection roast can be used for roasting meats, poultry and vegetables. During convection roast, the broil, convection, and bake elements will cycle on and off in intervals to maintain oven temperature, while the fan circulates the hot air. It is not necessary to reduce oven temperature when using the Convection Roast mode.

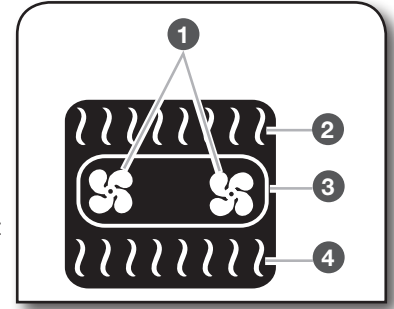

- 1 Convection fans
- 2 Broil element
- 3 Convection element
- 4 Bake element

If the oven door is opened during convection roasting, the fans turn off immediately and turn on immediately when the door is closed.

Bake, broil, and convection elements will turn off approximately 30 seconds after the door is opened. They will turn on again approximately 30 seconds after the door is closed.

- The cook time should be reduced 15–30%; however, food should be checked early to avoid over-cooking.
- For best results, use a broiler pan and grid designed to drain juices and help avoid spatter and smoke.
If you would like to purchase a Broiler Pan Kit, it may be ordered. See "Assistance or Service" section to order.

To Use Convection Roast:

Before using convection roast, see the "Positioning Racks and Bakeware" section. It is not necessary to wait for the oven to preheat before putting food in, unless recommended in the recipe.

1. Place food in oven.
2. Turn the Mode Knob to Convection Roast.
3. Turn the Temperature Knob to the desired cooking temperature.
4. Press the Start Button to begin cooking or preheating oven.
5. Turn the Temperature Knob to the OFF position to turn off the oven.



USING YOUR OVEN

CONVECT SLOW ROAST

The Convection Slow Roast mode uses low temperature to help retain moisture for longer cooking time, resulting in more tender meat. Convection Slow Roast is particularly good for medium to large cuts of beef, poultry and pork as well as less-tender cuts of meat. Food can be cooked up to 12 hours. The recipe temperature does not need to be reduced for this mode.

Know Your Slow Roast Mode

- Food should be completely thawed before cooking.
- Cover foods with aluminum foil to help retain moisture.
- Prior to slow roasting, meat can be pan-seared or broiled on all sides to enhance browning and flavor.

CONVECT PASTRY

This mode promotes maximum rise of flaky, delicate dough and finishing with the right balance of heat to promote golden browning. Convection pastry is ideal for single or multi-rack baking of cream puffs, turnovers and croissants.

CONVECT FROZEN PIZZA

Convection Frozen Pizza is used to bake thick- or thin-crust frozen pizzas. During operation, the elements will cycle on and off in intervals to maintain the oven temperature. The convection fans will cycle to distribute heat evenly throughout the cavity. Adjust the rack position up or down to increase or decrease top or bottom browning.

Know Your Convection Frozen Pizza Mode:

- Allow your oven to preheat completely before placing your pizza in the oven.
- If using a pizza stone, position the stone in a lower rack location and allow the oven to complete preheat. Typically, a minimum of 20 minutes is required to thoroughly preheat the baking stone.
- The fans and elements will turn off if the door is opened during operation and will turn on again after the door is closed.
- Reduce your bake temperature by 25°F (14°C) from the temperature recommended on the package.
- The bake time may be slightly less than stated on the package, depending on the pizza type.
- Convection Frozen Pizza is designed for single rack baking.

PROOF

The Proof cycle prepares dough for baking by activating the yeast. Follow recipe or package for number of times to proof dough.

RAPID PROOF

Rapid proof is used to proof commercially prepared frozen doughs.

Know Your Proof Mode

If the cavity temperature is more than 100°F (38°C) above Proof temperature, knob indicator lights will slowly blink until the oven is at the correct proof temperature.

Before Using Proof:

1. Place dough in a lightly greased bowl. Place bowl on rack position 2.
2. Close the door.

To Use Proof:

1. Turn the Mode Knob to the Bake position.
2. Turn the Temperature Knob to the Proof position.
3. Press the Start button.
4. When the cycle is complete, turn the Temperature Knob to the OFF position to end the cycle.

CULINARY CENTER

The Culinary Center is full of information to assist in baking and cooking a wide variety of foods. As you program this mode, you will make selections such as type of meat, vegetable, preferred doneness level, and pan type depending on the food. There are helpful tips and hints as you progress through the menu. The Culinary Center will make adjustments based on the doneness and pan you select. All of the selections cycle the appropriate elements and fans for the programmed food.

NOTE: Culinary Center can be accessed through the app.

NOTE: Some Culinary Center cycles require the use of the temperature probe provided with your oven. See Probe Operation for more information.



STEAM-ASSISTED COOKING

Steam-assisted cooking helps to retain moisture, texture, and flavor in food. The cycles are designed to provide the right amount of moisture at the right time for optimal results.

Auto Steam

Auto Steam has 7 settings: Meats, Poultry, Seafood, Breads, Vegetables, Desserts, and Casseroles. Auto Steam settings have default temperature and time settings to guide the cooking process. Choose the type of food being cooked, and select the desired temperature. If desired, both the temperature and time can be changed according to recipe recommendation.

NOTE: For optimal cooking results, avoid opening door during steam-assisted cooking. If the oven door is opened, steam production is automatically shut off until the door is closed.

- Steam eliminates the need for the use of parchment paper wraps (for cooking fish), water baths, and spritzing during the cooking process.
- When cooking with steam, place meat, poultry, seafood, vegetables, desserts, and casseroles into a cool oven. For best cooking results, allow the oven to cool down from previous cooking before steam cooking.
- If oven is warm from use, cooking times may be shorter.
- Optimum levels of moisture are introduced at the appropriate time during the cooking cycles.
- Specially developed cycles enhance browning on meats, poultry, and bread.
- When baking bread, preheating is required.
- When a steam-assisted set cook time has elapsed, the oven cooking cycle will continue to run until Off is pressed.

Auto Steam Time and Temperature Chart

AUTO STEAM FUNCTION	DEFAULT TEMPERATURE	COOK TIME
Meats	325°F (160°C)	1:30
Poultry	325°F (160°C)	1:30
Seafood	250°F (120°C)	0:25
Breads	400°F (205°C)	0:30
Vegetables	250°F (120°C)	0:30
Desserts	275°F (135°C)	0:30
Casseroles	350°F (175°C)	0:30

When using the Meats setting:

- For best results, use a broiler pan, grid, and roasting rack designed to drain juices and help avoid spatter and smoke.
- Preheating is not required. Place food in a cool oven.
- Roasting time may need to be reduced compared to convection and traditional roasting times.
- Use a meat thermometer to gauge doneness of food.

With traditional roasting, standing time is included before carving. The internal temperature will usually increase 5°F to 10°F (2°C to 5°C) during standing time. When roasting with the Steam Meats setting, the internal temperature may increase 15°F to 20°F (5°C to 10°C) during standing time; therefore, it is necessary to stop cooking and remove the meat at a lower internal temperature than with conventional roasting.

When using the Poultry setting:

- For best results, use a broiler pan, grid, and roasting rack.
- Preheating is not required. Place food in a cool oven.
- Roasting time may need to be reduced compared to convection and traditional roasting times.
- Use a meat thermometer to gauge doneness of food.

Breads

The Breads setting gives best results when baking yeast breads. With the addition of steam to the cycle, you no longer need to spritz with water or to add moisture into the oven to achieve a crispy crust and moist interior.

- Preheating is required.
- Baking times may be slightly less than with standard baking. The oven will preheat and it will then begin adding steam. The bread dough will go into a moist, hot environment which is best for rising and crust development.

After preheat, place the bread dough in the oven as quickly as possible and close the door. The cycle will end with dry heat for optimal browning.

Vegetables

The Vegetables setting frees up your cooktop for easy steaming in your oven.

- Preheating is not required. Place food in a cool oven.
- When steaming vegetables, use the default setting of 250°F and arrange the vegetables in a single layer on a low-sided baking pan.
- Check vegetables for doneness early. Freshness of the vegetable affects the required cooking time.
- Steaming artichokes, beets, green beans, and broccoli is not recommended.

Desserts

The Desserts setting gives best results for delicate desserts, such as crème brulee and cheesecake, that are typically baked in a water bath. This setting also works well for other custard-based dishes and souffles.

- Preheating is not required. Place food in a cool oven.
- Allows the center of a dessert to bake without overcooking the outer edges.
- It is not necessary to cook with a water bath.

Casseroles

The Casseroles setting allows you to bake an uncovered casserole without over-browning the edges or drying it out.

- Preheating is not required. Place food in a cool oven.
- Covering the food is not recommended.
- Allows the center of the casserole to bake without overcooking the outer edges.



USING YOUR OVEN

COOK TIMER (App Only)

The Cook Timer allows the oven to cook for a programmed length of time. The Cook Timer can be accessed through the app.

Follow the prompts in the app to use Cook Timer.

Know Your Cook Timer

The Cook Timer countdown is started several ways:

- If the cycle does not require preheat, the Cook Time starts immediately as the cycle begins.
- If a cycle requires preheat, the Cook Time can only be started through the app when the Start button is pressed.

TEMPERATURE PROBE (App Only)

The temperature probe is a tool to assist with evaluating the finish temperatures of meat, poultry and casseroles. It can be used during Bake, Convection Bake, and Convection Roast. The oven will beep when the food has reached the target temperature.

Know Your Temperature Probe

- Always unplug and remove the temperature probe from the oven when removing food.

Before Using Temperature Probe:

- Remove any racks above the food that are not in use.
- Insert the probe into the food item. For meats, the probe tip should be located in the center of the thickest part of the meat and not into the fat or touching a bone.
- For the most accurate temperature readings, insert as much of the probe shaft as possible into the food. Temperatures will be most accurate when more of the probe is inserted in the food.
- Place food in oven and connect the temperature probe to the jack.
- Keep probe as far away from heat source as possible. Close oven door.

DELAY START (App Only)

! WARNING

Food Poisoning Hazard

Do not let food sit in oven more than one hour before or after cooking.

Doing so can result in food poisoning or sickness.

Delay Start allows the oven(s) to be set to turn on at a certain time of day and cook for a set length of time.

Delay Start should not be used for food such as breads and cakes because they may not bake properly.

Delay Start is available with any cycle that has a Delay Start option. The Delay Start can be accessed through the app.

Follow the prompts in the app to use Delay Start.

NOTE: Do not use Delay Start for items that require a preheated oven, such as cakes, cookies and breads. If food is in the oven during preheat, it may become overcooked.



IMPORTANT:

- Before cleaning, make sure all cooktop knobs are OFF and the oven and cooktop are cool. Do not use oven cleaners, bleach, or rust removers.
- Soap, water, and a soft cloth or sponge are suggested first unless otherwise noted.

COOKTOP SURFACE

After Each Use:

1. Wipe off cooktop, grates, and caps.

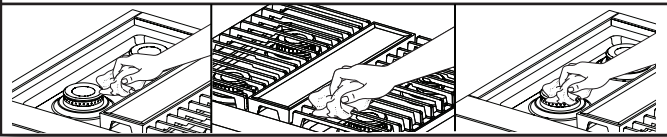

2. Clean food spills.

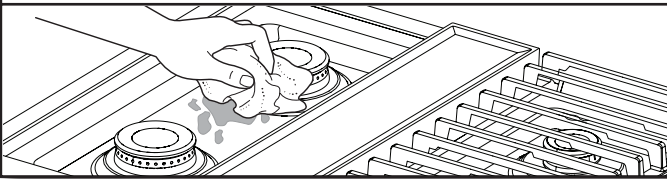

To preserve the finish, clean food spills containing acids, such as vinegar and tomato, as soon as the entire appliance is cool.

SEALED SURFACE BURNERS

1. Remove burner cap.

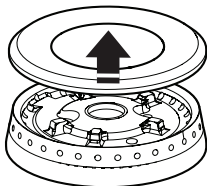

2. Clean gas opening with damp cloth.

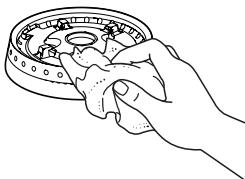

3. Clean clogged burner ports.

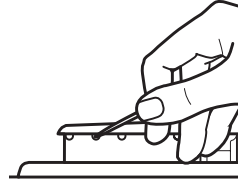

Use a straight pin. Do not enlarge or distort the port. Do not use a wooden toothpick. If the burner needs to be adjusted, contact a trained repair specialist.

4. Replace burner cap.

Burner

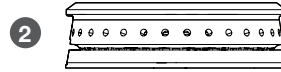
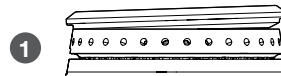

- 1 Incorrect
- 2 Correct

5. Turn on burner.

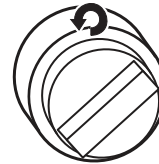

If the burner does not light, check cap alignment. If the burner still does not light, do not service the sealed burner yourself. Contact a trained repair specialist.



CARE AND CLEANING

PORCELAIN-COATED GRATES AND CAPS

Use scrub and cleanser.

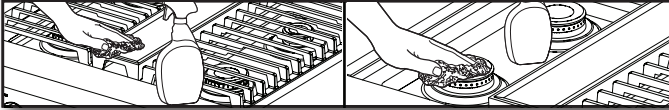

Clean with a nonabrasive nylon scrub pad and mildly abrasive cleanser.

Know Your Grates and Caps

- Food spills containing acids, such as vinegar and tomato, should be cleaned as soon as the cooktop, grates, and caps are cool. These spills may affect the finish.
- To avoid chipping, do not bang grates and caps against each other or hard surfaces such as cast iron cookware.
- Do not reassemble caps on burners while wet.
- Do not clean in the Self-Cleaning cycle.
- Do not clean in dishwasher.

GRILL

To Remove for Cleaning:

Before removing or replacing grill components, make sure the control knobs are turned to OFF. Allow the grill to cool completely before handling.

1. Remove grill grate and deflector.

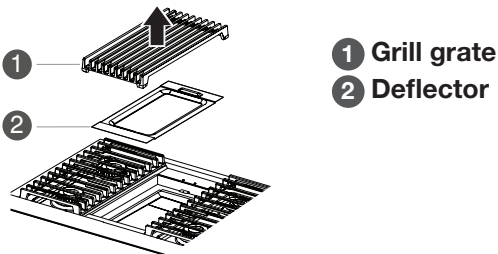

2. Remove and clean drip tray.

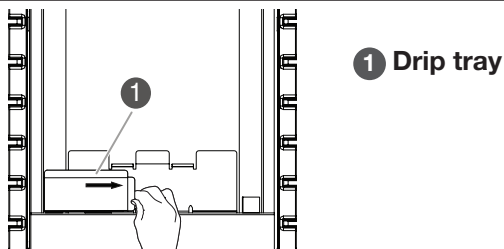

To Clean:

Do not use oven cleaners, metal brushes, abrasive scouring pads or other scrubbers made to clean grill components.

Grate:

- Do not clean grill grate in dishwasher.
- Do not clean in a self-cleaning oven.

1. Scrub with brush while grate is still warm.

Use a soft-bristle brush. Oven mitts may be worn while cleaning.

2. Soak in warm, soapy water for 30 minutes.

After soaking, scrub with nonabrasive pad.

Deflector:

Soak in warm, soapy water to loosen soil.

After soaking, scrub with non-abrasive pad.

Drip Tray:

- Allow cooktop to cool before cleaning.

Wipe with warm, soapy water or non-abrasive cleanser.

Use damp cloth or non-abrasive pad.

Module Basin:

1. Wipe with warm, soapy water or non-abrasive cleanser.

Use damp cloth or non-abrasive pad.

2. For heavy soil, soak with paper towels.

Soak paper towels in household cleanser and lay them on the soil for at least 30 minutes. After soaking, scrub with a nonabrasive pad.



To Replace:

1. Replace drip tray.

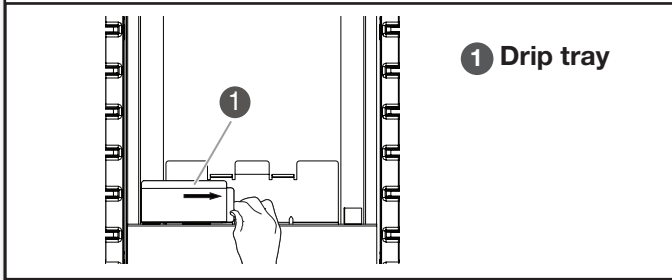

Slide drip tray into opening on the left front side of the grill basin.

2. Place deflector on top of burner assembly.

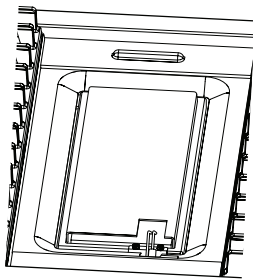

3. Place grill grate into position.

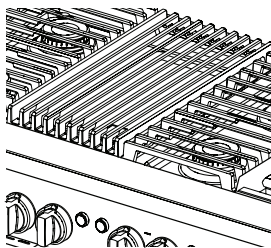

GRIDDLE

Tips:

- Prior to cleaning the griddle, make sure that all cooktop burners and oven controls have been turned off.
- For best results, clean the griddle shortly after removing the food.

Do Not Use:

- Soap
- Abrasive materials
- Cleaning materials, including stainless steel cleaner

After Each Use:

1. Turn knob to 300°F (149°C) to preheat.

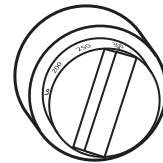

Wait until preheat is complete before cleaning.

2. Pour water on soiled area.

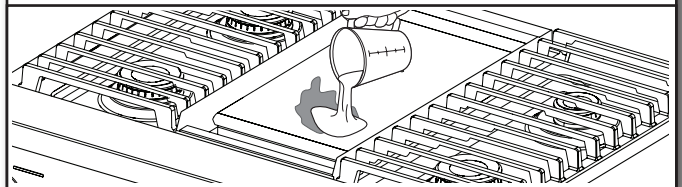

Using a measuring cup, pour up to 1 cup (236.6 mL) tap water over the soiled area. Start at the back, allowing the water to run toward the drip tray in the front. Allow the water to bubble on the griddle for 3–4 seconds.

3. Scrape residue into drip tray.

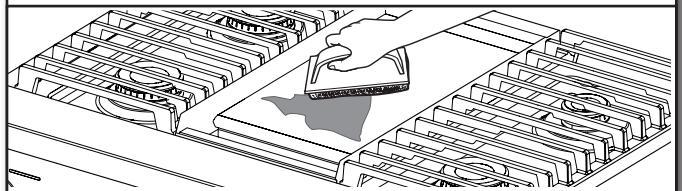

Use a pad holder or wooden spoon with a non-abrasive pad or cloth. Use pressure on soiled areas. Repeat if needed for heavy soils.



CARE AND CLEANING

4. Remove remaining residue.

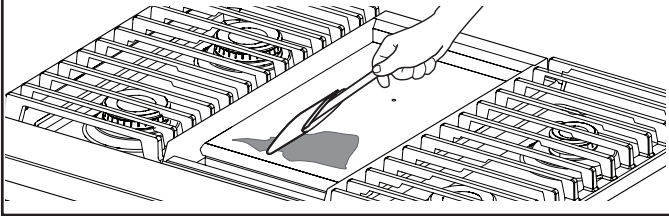

Fold a damp towel and, with the pad holder or wooden spoon, go over the griddle to remove remaining residue.

5. Turn off griddle and let cool.

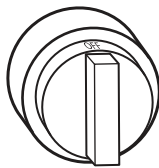

6. Wipe off griddle.

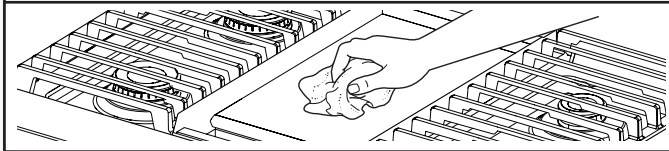

Once cool, wipe the griddle with a clean, damp terry cloth towel. Then buff with a microfiber cloth. If streaking, rainbowing, or ghosting occurs, use a mixture of 1 part white vinegar to 2 parts water on a towel to wipe the griddle.

7. Remove, empty, and clean drip tray.

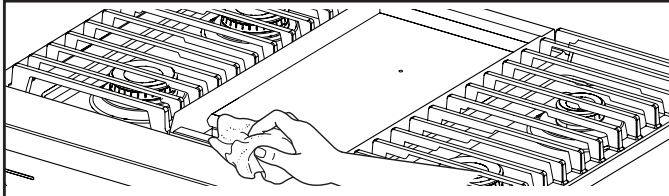

Clean the drip tray with warm, soapy water. Wipe the area under the drip tray clean. Once dry, put the drip tray back in position.

COOKTOP CONTROLS

1. Remove knobs.



Pull the knobs straight away from the control panel to remove.

2. Clean with warm, soapy water.

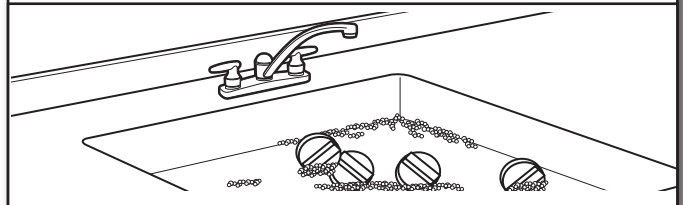

Know Your Cooktop Controls

- To avoid damage to the cooktop controls, do not use steel wool, abrasive cleansers, or an oven cleaner.
- To avoid damage, do not soak knobs.
- When replacing knobs, make sure knobs are in the Off position.
- When replacing knobs after cleaning either the surface burner controls or the griddle module control, make sure the knobs are replaced to the correct location. See the "Knob Variations" section for reference.

STAINLESS STEEL

Use cleaner or wipes.

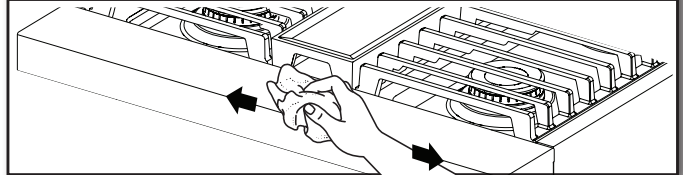

Use affresh® Stainless Steel Cleaner or affresh® Stainless Steel Cleaning Wipes (not included). Rub in direction of grain to avoid possible damage to the steel surface.

Do Not Use:

- Soap-filled scouring pads
- Abrasive cleaners
- Cooktop polishing creme
- Steel-wool pads
- Gritty washcloths
- Abrasive paper towels



DOOR EXTERIOR

Apply cleaner.



Apply glass cleaner to a soft cloth or sponge, not directly on the glass, or use affresh® Kitchen and Appliance Cleaner (not included).

DOOR INTERIOR

1. Wipe away any deposits.



Use a damp sponge.

2. Use Self-Cleaning cycle.

See the "Self-Cleaning the Oven" section.

OVEN RACKS

1. Empty out oven and remove racks.

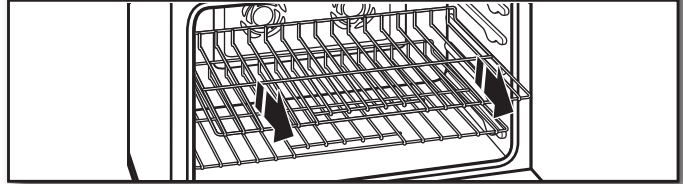

IMPORTANT: Remove racks before the Self-Cleaning cycle to avoid discoloring and difficulty sliding.

2. Use non-abrasive pad or cloth.

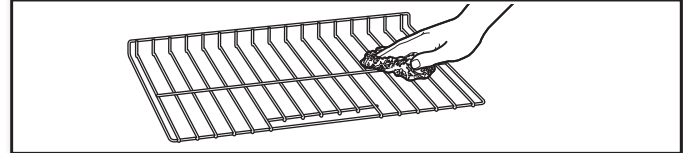

OVEN CAVITY

- Do not use oven cleaners.
- Food spills should be cleaned when oven cools. At high temperatures, foods react with porcelain. Staining, etching, pitting, or faint white spots can result.

BROIL ELEMENT

- Do not use oven cleaners.
- To maintain optimal performance, wipe surface with soapy water to remove soil residue when oven completely cools.
- Apply glass cleaner or affresh® Kitchen and Appliance cleaner (not included) to a soft cloth or sponge, not directly on the glass cover.
- If soil build-up becomes visible or difficult to clean, use the self-clean cycle to thoroughly clean glass.



CARE AND CLEANING

SELF-CLEANING THE OVEN

⚠️ WARNING



Burn Hazard

Do not touch the oven during the Self-Cleaning cycle.

Keep children away from oven during Self-Cleaning cycle.

Failure to follow these instructions can result in burns.

IMPORTANT:

- The health of some birds is extremely sensitive to the fumes given off during the Self-Cleaning cycle. Exposure to the fumes may result in death to certain birds. Always move birds to another closed and well-ventilated room.
- Self-clean the oven before it becomes heavily soiled. Heavy soil results in longer cleaning and more smoke.
- Remove broiler pan, grid, cookware, and bakeware and, the meat probe from the oven.
- Keep the kitchen well-ventilated during the Self-Cleaning cycle to help get rid of heat, odors, and smoke.
- Do not block the oven vent(s) during the Self-Cleaning cycle. Air must be able to move freely. See "Oven Vent" in the "Know Your Oven" section.
- Do not clean, rub, damage, or move the oven door gasket. The door gasket is essential for a good seal.

To Prepare Oven:

1. Empty out oven and remove racks.

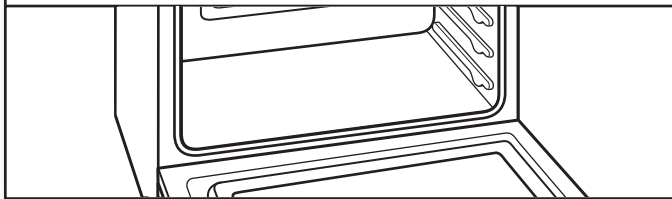

Remove broiler pan, grid, cookware and bakeware, and the meat probe from the oven.

IMPORTANT: Remove racks before the Self-Cleaning cycle to avoid discoloring and difficulty sliding.

2. Remove any foil from oven.

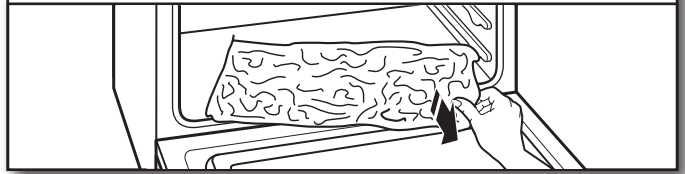

Foil may burn or melt, damaging the oven.

3. Hand clean.

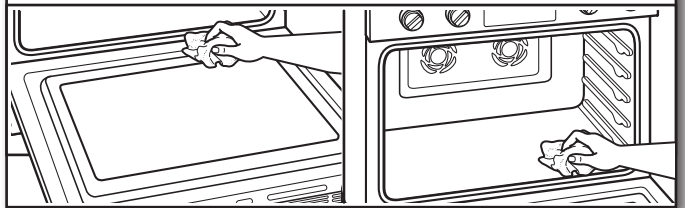

With a damp cloth, hand clean the inside door edge and 1½" (3.8 cm) of the area around the inside oven cavity frame. Be certain not to move or bend the gasket. This area does not get hot enough during self-cleaning to remove soil. Do not let water, cleaners, etc., enter the slots on the door frame.

4. Wipe out loose soil.

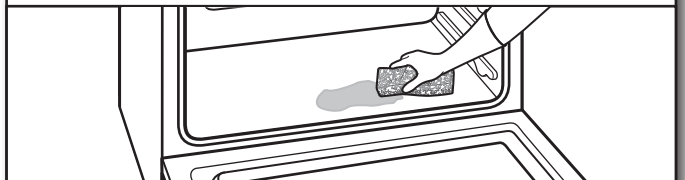

Wiping out soil reduces smoke and avoids damage. At high temperatures, foods react with porcelain. Staining, etching, pitting, or faint white spots can result. This will not affect cooking performance.

To Prepare Cooktop:

5. Remove plastic items.

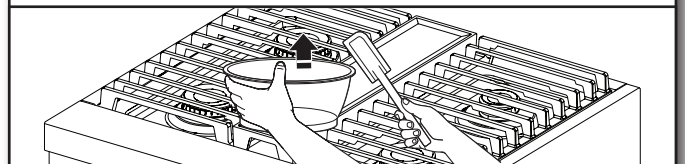

Plastic items may melt.



How the Cycle Works

IMPORTANT:

- The heating and cooling of porcelain on steel in the oven may result in discoloring, loss of gloss, hairline cracks, and popping sounds.
- The Self-Cleaning cycle uses very high temperatures, burning soil to a powdery ash.
- Heavy soil accumulations may require multiple cleaning cycles.
- The oven is preset for a 3 hour 30 minute Self-Cleaning cycle. The oven will cool for an additional 30 minutes after cleaning is completed.

To Use Self-Clean:

Turn the Mode and Temperature Knobs to the Clean position. The knob indicator lights will illuminate to show that a selection has been made.

The Start button indicator light will blink to prompt for action. Press the Start button to begin the cleaning cycle.

The door(s) will lock.

NOTE: The oven will cool for an additional 30 minutes after cleaning is completed.

To Start Self-Clean:

1. Turn the Mode Knob to the Clean position.
2. Turn the Temperature Knob to the Clean position.
3. Press the Start Button.

NOTE: All operations must be completed within 30 seconds or the unit will return to Idle Mode.

REMEMBER: When range is in use or during the Self-Cleaning cycle, the entire cooktop area may become hot.

To Stop Self-Clean Any Time:

Move the Temperature Knob to OFF position to stop self-clean. If the oven temperature is too high, the door will remain locked. It will not unlock until the oven cools.

Once the oven has completely cooled:

- Remove ash with a damp cloth.
- If soil remains after wiping, that means the length of the Self-Cleaning cycle was not long enough for the amount of soil in the oven. Repeat the Self-Cleaning cycle if desired or the soil will be removed during the next Self-Cleaning cycle.
- To avoid breaking the glass, do not apply a cool damp cloth to the inner door glass before it has completely cooled.
- The oven lights will not light during the Self-Cleaning cycle.
- On 48" (121.9 cm) ranges, only one oven can self-clean at a time. If one oven is self-cleaning, the other oven cannot be set or turned on.

NOTE: The oven has a dual speed cooling fan motor. During self-cleaning, the fan(s) will operate at their highest speed to increase airflow to better exhaust the hotter air through the oven vent(s). An increase of noise may be noticeable during and after the Self-Cleaning cycle until the oven cools.



OVEN LIGHTS

The oven lights are 120 V, 25 W maximum halogen bulbs. They will come on when the oven door is opened.

To Replace:

Before replacing the bulb, make sure the oven is OFF and cool.

Disconnect power.

1. Remove glass light cover.

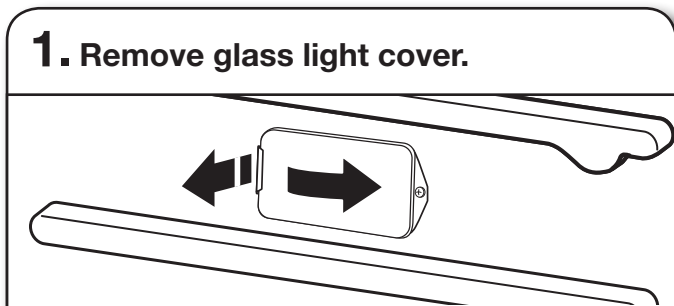

Grasp the front edge, and pull away from the oven.

2. Remove bulb from socket.

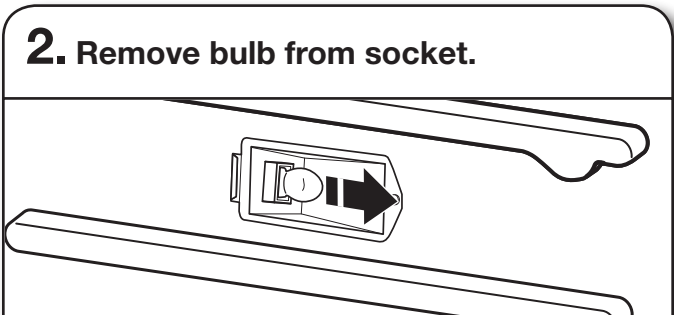

3. Replace bulb.

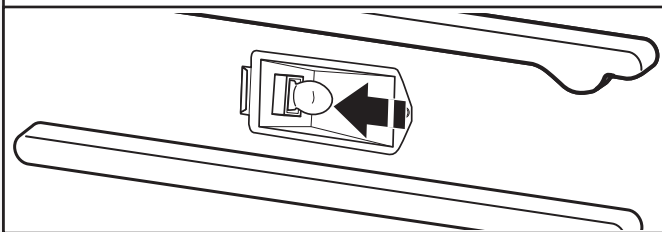

Use a tissue or wear cotton gloves to handle the bulb. To avoid damage or decreasing the life of the new bulb, do not touch bulb with bare fingers.

4. Replace bulb cover.

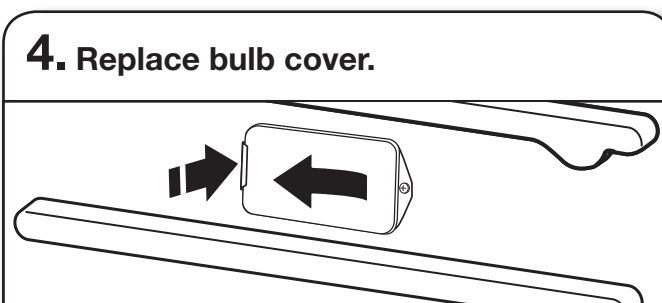

Snap back into the wall.
Reconnect power.

TROUBLESHOOTING



First try the solutions suggested here. If you need further assistance or more recommendations that may help you avoid a service call, refer to the "Warranty," or visit <https://jennair.custhelp.com>. In Canada, visit <http://www.jennair.ca>.

IF YOU EXPERIENCE	POSSIBLE CAUSES	SOLUTION
Nothing will operate.	A household fuse has blown or a circuit breaker has tripped.	Replace the fuse or reset the circuit breaker. If the problem continues, call an electrician.
Surface burners will not operate.	This is the first time the surface burners have been used.	Turn on any one of the surface burner knobs to release air from the gas lines.
	The control knob is not set correctly.	Push in knob before turning to a setting.
	The burner ports are clogged.	Clean clogged burner ports with a straight pin.
Surface burner flames are uneven, yellow, and/or noisy.	The burner ports are clogged.	Clean clogged burner ports with a straight pin.
	The burner caps are not positioned properly.	Make sure cap is properly aligned with the burner.
	Propane gas is being used.	The range may have been converted improperly. Contact a trained repair specialist.
Surface burner makes popping noises.	The burner is wet.	Let it dry.
Burner sparks but does not light.	There is continuous sparking, but the burner does not light.	Make sure cap is properly aligned with burner. If sparking continues, discontinue use of the surface burner and contact a service technician.
Excessive heat around cookware on cooktop.	The cookware is not the proper size.	Use cookware about the same size as the surface cooking area or surface burner. Cookware should not extend more than 1/2" (1.3 cm) outside the cooking area.
Cooktop cooking results not what expected.	The proper cookware is not being used.	Use medium-to-heavy cookware made of the material that cooks food the way you want. The best cookware should have a flat bottom, straight sides, and a well-fitting lid.
	The control knob is not set to the proper heat level.	Set the Cooktop Control to HI, MED, or LO, depending upon the type of cooking you want to do.
	The range is not level.	The range must be level for the griddle to operate properly. See the Installation Instructions for leveling instructions.
Oven will not operate.	The electronic oven control is not set correctly.	Make sure you have followed the instructions for the function you want to perform.
	A Delay Start has been set via the App.	This will cause the oven to start at a later time.
	On some models, the Sabbath Mode is set.	This mode allows oven operation in keeping with the Jewish Sabbath. See Sabbath Mode section for disabling.
Cooling fan runs during baking, broiling, or cleaning.		It is normal for the fan to automatically run while the oven is in use or for some time after the oven is shut off to cool the electronic control.
Self-Cleaning cycle will not operate.	The oven door is open.	Close the oven door all the way.
	The function has not been entered.	Make sure you have properly followed the Self-Cleaning cycle instructions.
	A second self-cleaning cycle is run in the same cavity within 12 hours.	Allow more than 12 hours between self-cleaning cycles.
	On 48" (121.9 cm) ranges, one oven is self-cleaning.	When one oven is self-cleaning, the other oven cannot be set to self-clean.



TROUBLESHOOTING

First try the solutions suggested here. If you need further assistance or more recommendations that may help you avoid a service call, refer to the "Warranty," or visit <https://jennair.custhelp.com>. In Canada, visit <http://www.jennair.ca>.

IF YOU EXPERIENCE	POSSIBLE CAUSES	SOLUTION
Oven cooking results not what expected.	The set temperature did not perform as expected.	Double-check the recipe in a reliable cookbook.
	The oven was not preheated.	If the proper steps are followed when setting the desired function, the oven will preheat before cooking.
	The proper bakeware is not being used.	Make sure the bakeware used is appropriate for the food being cooked.
	The racks are not positioned properly.	Place racks so there is adequate space above each food item.
	There is not proper air circulation around bakeware.	Allow 2" (5.0 cm) of space around bakeware and oven walls.
	The batter is not evenly distributed in the pan.	Make sure your unit and racks are level, and check that batter is level in the pan.
	The proper length of time is not being used.	Adjust cooking time.
	The oven door has been opened while cooking.	Oven peeking releases oven heat and can result in longer cooking times.
	Baked items are too brown on the top or bottom.	Move rack to a lower location to reduce top browning or to a higher location to reduce bottom browning in the oven.
	Pie crust edges are browning early.	Use aluminum foil to cover the edge of the crust and/or reduce baking temperature.
	Racks are difficult to install in adjacent positions.	Install the bottom rack first and then install the rack above it.
	Soiled broil element cover drops debris on baking dishes.	Wash cover with soapy water or run Self-Clean cycle to remove build-up.

ASSISTANCE OR SERVICE



Before calling for assistance or service, please check "Troubleshooting." It may save you the cost of a service call. If you still need help, follow the instructions below. When calling, please know the purchase date and the complete model and serial number of your appliance. This information will help us to better respond to your request.

If You Need Replacement Parts

If you need to order replacement parts, we recommend that you use only factory specified parts. These factory specified parts will fit right and work right because they are made with the same precision used to build every new JennAir® appliance.

To locate factory specified parts in your area, call us or your nearest JennAir designated service center.

In the U.S.A.

Call the JennAir Customer eXperience Center toll-free: **1-800-JENNAIR (1-800-536-6247)** or visit our website at **www.jennair.com**.

Our consultants provide assistance with:

- Scheduling of service. JennAir® appliances designated service technicians are trained to fulfill the product warranty and provide after-warranty service anywhere in the United States.
- Features and specifications on our full line of appliances.
- Referrals to local JennAir® appliance dealers.
- Installation information.
- Use and maintenance procedures.
- Accessory and repair parts sales.
- Specialized customer assistance (Spanish speaking, hearing impaired, limited vision, etc.).

For further assistance

If you need further assistance, you can write to JennAir with any questions or concerns at:

JennAir Brand Home Appliances
Customer eXperience Center
553 Benson Road
Benton Harbor, MI 49022-2692

Please include a daytime phone number in your correspondence.

In Canada

Call the JennAir Canada Customer eXperience Centre toll-free: **1-800-JENNAIR (1-800-536-6247)** or visit our website at **www.jennair.ca**.

Our consultants provide assistance with:

- Scheduling of service. JennAir® appliances designated service technicians are trained to fulfill the product warranty and provide after-warranty service anywhere in Canada.
- Features and specifications on our full line of appliances.
- Referrals to local JennAir® appliance dealers.
- Installation information.
- Use and maintenance procedures.
- Accessory and repair parts sales.

For further assistance

If you need further assistance, you can write to JennAir Canada with any questions or concerns at:

Customer eXperience Centre
JennAir Canada
200 - 6750 Century Ave.
Mississauga, Ontario L5N 0B7

Please include a daytime phone number in your correspondence.

ACCESSORIES



For accessories in the U.S.A., you can visit our website at **www.jennair.com** or call us at **1-800-JENNAIR (1-800-536-6247)**.

In Canada, visit our website at **www.jennair.ca** or call us at **1-800-JENNAIR (1-800-536-6247)**.

Affresh® Stainless Steel Cleaner

(stainless steel models)

Affresh® Stainless Steel Cleaning Wipes

(stainless steel models)

Gas Grate/Drip Pan Cleaner

Affresh® Kitchen and Appliance Cleaner

Stainless Steel Grill Cover

Wok Ring

Extendable Roller Rack with Handle

Broiler Pan Kit

Backguard and Backsplash

Brass Burner Caps

Chrome/Brass Bezels

W11114330C

®/™ ©2019 All rights reserved. Used under license in Canada.
Tous droits réservés. Utilisé sous licence au Canada.

01/19

16-Jan-2019 04:15:32 EST | RELEASED

In some European factories the letter "W" of the part code mentioned herein will be automatically replaced by the number "4000" (e.g. "W12345678" becomes "400012345678")