



BUILT-IN MICROWAVE OVEN

Use & Care Guide

For questions about features, operation/performance, parts, accessories or service, call: **1-866-664-2449**.

In Canada, for assistance, installation or service, call: **1-866-664-2449**.

For warranty concerns, do not take the appliance back to the store. Please contact us in U.S.A. or Canada at **1-866-664-2449**.

This product features a Limited Warranty - See the "Warranty" section for complete details. IKEA® appliances carry a 5-year warranty (excludes LAGAN family - see warranty for coverage details).

NOTE: Proof of Purchase is required to obtain warranty service.

FOUR À MICRO-ONDES ENCASTRÉ

Guide d'utilisation et d'entretien

Au Canada, pour assistance, installation ou service composez le **1-866-664-2449**.

Pour toute question concernant l'application de la garantie, ne pas rapporter l'appareil au magasin. Veuillez nous contacter aux É.-U. ou au Canada au **1-866-664-2449**.

Ce produit est couvert par une garantie limitée - Voir la section "Garantie" pour des détails complets. Les appareils IKEA® sont couverts par une garantie de 5 ans (hormis les appareils de la série LAGAN - voir la garantie pour des détails concernant les modalités de garantie).

REMARQUE : Une preuve d'achat est obligatoire pour obtenir l'application de la garantie.

COMBINACIÓN DE HORNO/MICROONDAS

Manual de uso y cuidado

Si tiene preguntas respecto a las características, funcionamiento, rendimiento, partes, accesorios o servicio técnico, llame al: **1-866-664-2449**.

Si tiene dudas acerca de la garantía, no devuelva el aparato a la tienda. Póngase en contacto con nosotros en los EE.UU. o en Canadá al **1-866-664-2449**.

Este producto tiene una garantía limitada - Consulte la sección "Garantía" para obtener todos los detalles. Los aparatos IKEA® tienen una garantía de 5 años (excluyendo los de la familia LAGAN, consulte la garantía para ver los detalles acerca de la cobertura).

NOTA: Se requiere el comprobante de compra para obtener servicio bajo la garantía.

Table of Contents/Table des matières/ Índice..... 2

TABLE OF CONTENTS

| | | | |
|---|----------|------------------------------------|-----------|
| BUILT-IN MICROWAVE OVEN SAFETY | 3 | Cooking Guidelines | 7 |
| Electrical Requirements | 5 | Cookware and Dinnerware..... | 8 |
| PARTS AND FEATURES | 5 | Aluminum Foil and Metal | 8 |
| Turntable..... | 5 | Microwave Cooking Power | 8 |
| MICROWAVE OVEN CONTROL | 6 | Cook Time Set..... | 9 |
| Display..... | 6 | Doneness | 9 |
| Start..... | 6 | Meal Prep Cook | 9 |
| Off/Cancel | 6 | Meal Prep Reheat..... | 10 |
| Add 30 Sec..... | 6 | Meal Prep Defrost | 10 |
| Dial..... | 6 | Quick-Touch Cooking | 11 |
| Select..... | 6 | Keep Warm..... | 11 |
| Clock | 6 | MICROWAVE OVEN CARE | 12 |
| Tones | 6 | General Cleaning..... | 12 |
| Demo Mode..... | 7 | TROUBLESHOOTING | 13 |
| Control Lock..... | 7 | ASSISTANCE OR SERVICE | 14 |
| Cooling Fan | 7 | In the U.S.A. | 14 |
| MICROWAVE OVEN USE | 7 | In Canada | 14 |
| Food Characteristics | 7 | Replacement Parts..... | 14 |

TABLE DES MATIÈRES

| | | | |
|--|-----------|--|-----------|
| SÉCURITÉ DU FOUR À MICRO-ONDES ENCASTRÉ | 15 | Guide de cuisson | 20 |
| Spécifications électriques | 17 | Ustensiles de cuisson et vaisselle | 20 |
| PIÈCES ET CARACTÉRISTIQUES | 17 | Papier d'aluminium et métal | 21 |
| Plateau rotatif | 17 | Puissance de cuisson du four à micro-ondes | 21 |
| COMMANDE DU FOUR À MICRO-ONDES | 18 | Réglage de la minuterie | 22 |
| Affichage | 18 | Degré de cuisson | 22 |
| Mise en marche..... | 18 | Préparation des repas – cuire | 22 |
| Arrêt/annulation..... | 18 | Préparation des repas – réchauffer..... | 23 |
| Ajouter 30 s | 18 | Préparation des repas – décongeler..... | 23 |
| Roulette | 18 | Touches rapides de cuisson | 24 |
| Sélectionner | 18 | Maintien au chaud..... | 25 |
| Horloge..... | 18 | ENTRETIEN DU FOUR À MICRO-ONDES | 26 |
| Signaux sonores..... | 18 | Nettoyage général..... | 26 |
| Mode de démonstration..... | 19 | DÉPANNAGE | 27 |
| Verrouillage des commandes..... | 19 | ASSISTANCE OU DÉPANNAGE | 28 |
| Ventilateur de refroidissement..... | 19 | Aux É.-U. | 28 |
| UTILISATION DU FOUR À MICRO-ONDES | 19 | Au Canada..... | 28 |
| Caractéristiques des aliments..... | 19 | Pièces de rechange..... | 28 |

ÍNDICE

| | | | |
|--|-----------|--|-----------|
| SEGURIDAD EL COIMBINACIÓN DE HORNO/MICROONDAS | 29 | Pautas para cocinar | 33 |
| Requisitos eléctricos | 31 | Utensilios de cocina y vajilla | 34 |
| PIEZAS Y CARACTERÍSTICAS | 31 | Papel de aluminio y metal | 34 |
| Bandeja giratoria | 31 | Potencia de cocción del microondas | 35 |
| CONTROL DEL HORNO DE MICROONDAS | 32 | Tiempo de cocción fijado..... | 35 |
| Pantalla..... | 32 | Punto de cocción | 35 |
| Inicio | 32 | Preparación de comida, Cocción | 36 |
| Off/Cancel | 32 | Preparación de comida, Recalentamiento | 36 |
| Agregar 30 segundos..... | 32 | Preparación de comida, Descongelado | 37 |
| Cuadrante..... | 32 | Cocción rápida..... | 37 |
| Seleccione..... | 32 | Mantener tibio | 38 |
| Reloj..... | 32 | CUIDADO DEL HORNO DE MICROONDAS | 39 |
| Tonos..... | 32 | Limpieza general | 39 |
| Modo de demostración..... | 33 | SOLUCIÓN DE PROBLEMAS | 40 |
| Bloqueo de controles..... | 33 | AYUDA O SERVICIO TÉCNICO | 41 |
| Ventilador de enfriamiento | 33 | En los EE. UU. | 41 |
| USO DEL HORNO DE MICROONDAS | 33 | En Canadá..... | 41 |
| Características de los alimentos..... | 33 | Piezas de repuesto..... | 41 |
| | | WARRANTY | 42 |

BUILT-IN MICROWAVE OVEN SAFETY

Your safety and the safety of others are very important.

We have provided many important safety messages in this manual and on your appliance. Always read and obey all safety messages.



This is the safety alert symbol.

This symbol alerts you to potential hazards that can kill or hurt you and others.

All safety messages will follow the safety alert symbol and either the word “DANGER” or “WARNING.” These words mean:

⚠ DANGER

You can be killed or seriously injured if you don't immediately follow instructions.

⚠ WARNING

You can be killed or seriously injured if you don't follow instructions.

All safety messages will tell you what the potential hazard is, tell you how to reduce the chance of injury, and tell you what can happen if the instructions are not followed.

IMPORTANT SAFETY INSTRUCTIONS

When using electrical appliances basic safety precautions should be followed, including the following:

WARNING: To reduce the risk of burns, electric shock, fire, injury to persons, or exposure to excessive microwave energy:

- Read all instructions before using the microwave oven.
- Read and follow the specific “PRECAUTIONS TO AVOID POSSIBLE EXPOSURE TO EXCESSIVE MICROWAVE ENERGY” found in this section.
- The microwave oven must be grounded. Connect only to properly grounded outlet. See “GROUNDING INSTRUCTIONS” found in the “INSTALLATION INSTRUCTIONS” section.
- Install or locate the microwave oven only in accordance with the provided Installation Instructions.
- Some products such as whole eggs in the shell and sealed containers - for example, closed glass jars - are able to explode and should not be heated in the microwave oven.
- Use the microwave oven only for its intended use as described in the manual. Do not use corrosive chemicals or vapors in the microwave oven. This type of oven is specifically designed to heat, cook, or dry food. It is not designed for industrial or laboratory use.
- As with any appliance, close supervision is necessary when used by children.
- Do not operate the microwave oven if it has a damaged cord or plug, if it is not working properly, or if it has been damaged or dropped.
- The microwave oven should be serviced only by qualified service personnel. Call an authorized service company for examination, repair, or adjustment.
- Do not cover or block any openings on the microwave oven.
- Do not store this microwave oven outdoors. Do not use the microwave oven near water - for example, near a kitchen sink, in a wet basement, near a swimming pool, or similar locations.
- Do not immerse cord or plug in water.
- Keep cord away from heated surfaces.
- Do not let cord hang over edge of table or counter.
- See door surface cleaning instructions in the “Microwave Oven Care” section.
- To reduce the risk of fire in the oven cavity:
 - Do not overcook food. Carefully attend the microwave oven when paper, plastic, or other combustible materials are placed inside the oven to facilitate cooking.
 - Remove wire twist-ties from paper or plastic bags before placing bags in oven.
 - If materials inside the oven ignite, keep oven door closed, turn oven off, and disconnect the power cord, or shut off power at the fuse or circuit breaker panel.
 - Do not use the cavity for storage purposes. Do not leave paper products, cooking utensils, or food in the cavity when not in use.

SAVE THESE INSTRUCTIONS

IMPORTANT SAFETY INSTRUCTIONS

- Liquids, such as water, coffee, or tea are able to be overheated beyond the boiling point without appearing to be boiling. Visible bubbling or boiling when the container is removed from the microwave oven is not always present. THIS COULD RESULT IN VERY HOT LIQUIDS SUDDENLY BOILING OVER WHEN THE CONTAINER IS DISTURBED OR A SPOON OR OTHER UTENSIL IS INSERTED INTO THE LIQUID.

To reduce the risk of injury to persons:

- Do not overheat the liquid.
- Stir the liquid both before and halfway through heating it.
- Do not use straight-sided containers with narrow necks.
- After heating, allow the container to stand in the microwave oven for a short time before removing the container.
- Use extreme care when inserting a spoon or other utensil into the container.

- Do not mount over a sink.
- Oversized foods or oversized metal utensils should not be inserted in the microwave oven as they may create a fire or risk of electric shock.
- Do not clean with metal scouring pads. Pieces can burn off the pad and touch electrical parts involving a risk of electric shock.
- Do not store any materials, other than manufacturer's recommended accessories, in this microwave oven when not in use.
- Do not cover racks or any other part of the microwave oven with metal foil. This will cause overheating of the microwave oven.

SAVE THESE INSTRUCTIONS

PRECAUTIONS TO AVOID POSSIBLE EXPOSURE TO EXCESSIVE MICROWAVE ENERGY

- (a) Do not attempt to operate this oven with the door open since open-door operation can result in harmful exposure to microwave energy. It is important not to defeat or tamper with the safety interlocks.
- (b) Do not place any object between the oven front face and the door or allow soil or cleaner residue to accumulate on sealing surfaces.
- (c) Do not operate the oven if it is damaged. It is particularly important that the oven door close properly and that there is no damage to the:
 - (1) Door (bent),
 - (2) Hinges and latches (broken or loosened),
 - (3) Door seals and sealing surfaces.
- (d) The oven should not be adjusted or repaired by anyone except properly qualified service personnel.

State of California Proposition 65 Warnings:

WARNING: This product contains one or more chemicals known to the State of California to cause cancer.

WARNING: This product contains one or more chemicals known to the State of California to cause birth defects or other reproductive harm.

Electrical Requirements

⚠ WARNING



Electrical Shock Hazard

Plug into a grounded 3 prong outlet.

Do not remove ground prong.

Do not use an adapter.

Do not use an extension cord.

Failure to follow these instructions can result in death, fire, or electrical shock.

Observe all governing codes and ordinances.

Required:

- A 120-volt, 60 Hz, AC-only, 15- or 20-amp electrical supply with a fuse or circuit breaker.

Recommended:

- A time-delay fuse or time-delay circuit breaker.
- A separate circuit serving only this microwave oven.

GROUNDING INSTRUCTIONS

■ For all cord connected appliances:

The microwave oven must be grounded. In the event of an electrical short circuit, grounding reduces the risk of electric shock by providing an escape wire for the electric current. The microwave oven is equipped with a cord having a grounding wire with a grounding plug. The plug must be plugged into an outlet that is properly installed and grounded.

WARNING: Improper use of the grounding plug can result in a risk of electric shock. Consult a qualified electrician or serviceman if the grounding instructions are not completely understood, or if doubt exists as to whether the microwave oven is properly grounded.

Do not use an extension cord. If the power supply cord is too short, have a qualified electrician or serviceman install an outlet near the microwave oven. A short power supply cord is provided to reduce the risks resulting from becoming entangled in or tripping over a longer cord.

SAVE THESE INSTRUCTIONS

This device complies with Part 18 of the FCC Rules.
This device complies with Industry Canada ICES-001.

PARTS AND FEATURES

This manual may cover several different models. The model you have purchased may have some or all of the features shown here. The appearance of your particular model may differ slightly from the illustrations in this manual.

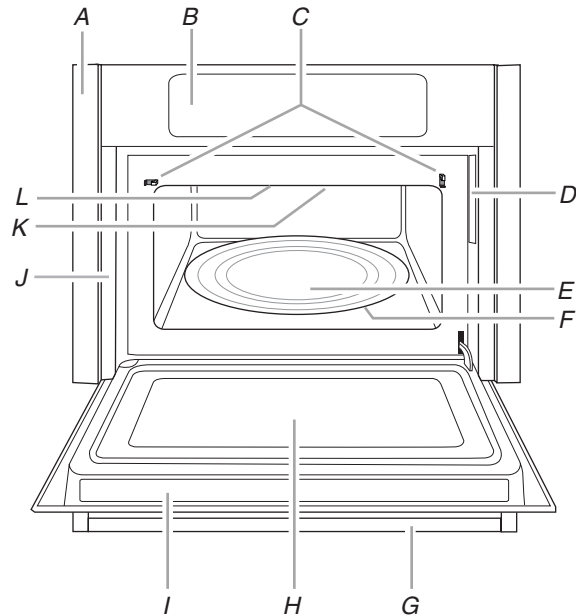

- | | |
|--|---|
| A. Trim | G. Door handle |
| B. Control panel | H. Window |
| C. Door lock system | I. Cooking guide label |
| D. Model and serial number plate | J. Frame |
| E. Glass turntable | K. Microwave oven light (inaccessible - in ceiling) |
| F. Turntable support, rollers, and hub | L. Microwave inlet cover |

Turntable

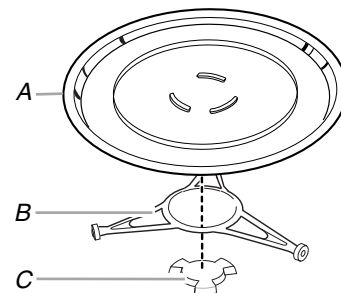

- A. Turntable
B. Support
C. Hub

The turntable can rotate in either direction to help cook food more evenly. For best cooking results, do not operate the microwave oven without having the turntable in place. See the "Assistance or Service" section to reorder any of the parts.

To Install:

1. Place the support on the microwave oven cavity bottom.
2. Place the turntable on the support.

Fit the raised, curved wedges in the center of the turntable bottom between the 3 spokes of the hub. The rollers on the support should fit inside the turntable bottom ridge.

MICROWAVE OVEN CONTROL



Display

When power is first supplied to the microwave oven, a “:” will blink in the display. Touch OFF/CANCEL to stop the blinking. If the “:” blinks in the display at any other time, a power failure has occurred. Touch OFF/CANCEL and reset the clock if needed.

When the microwave oven is in use, the display shows cooking power, quantities, weights, and/or prompts. When the microwave oven is not in use, the display shows the time of day.

Start

The Start keypad begins any function. If cooking is interrupted, touching START will resume the preset cycle.

NOTE: To avoid unintentional operation of the microwave oven, a cooking function cannot be started if the microwave oven door has been closed for about 1 minute or more. “DOOR” will appear in the display until the door is opened and closed.

Off/Cancel

The Off/Cancel keypad clears any incorrect command and cancels most functions except for the Control Lock and Demo mode. It will not erase the time of day unless the display is in clock-setting mode. See “Clock” section.

The microwave oven will also turn off when the door is opened. Close the door and touch START to resume the cycle.

Add 30 Sec

The Add 30 Sec keypad automatically starts the microwave oven at 100% power for 30 seconds. Each additional touch of the control will add 30 seconds of cook time, up to a total cook time of 10 minutes.

Cook time may be added to a cooking cycle at the current power level by touching ADD 30 SEC. During a manual cooking cycle, each touch of the ADD 30 SEC keypad will add 30 seconds of cook time, up to a total remaining cook time of 10 minutes. The Add 30 Sec keypad will not add minutes to a cycle that has a remaining cook time of 10 minutes or more.

Dial

Use the dial to select options, set the clock, set cook time and cook power, select food type and amount/weight, and adjust doneness.

To Use: Push dial and release to pop it out. Repeat to return dial to its flush position after each use to avoid breakage of the dial.

Select

Use the Select keypad to select a chosen function and to set the following options:

- Select a setting or food type and go to the next step.
- Set or cancel clock. See the “Clock” section.
- Set weight measurements to oz or lbs.
- Set amount measurements to pieces, cups, or servings.

See the “Meal Prep” sections for details on using the Select keypad with the automatic cooking, reheating, and defrosting programs.

Clock

This is a standard 12-hour clock (12:00-11:59).

To Set:

1. Touch and hold SELECT for 5 seconds.
“12:00” will appear in the display with the hour (12) flashing. If you are changing the time, the current set time will appear with the hour flashing.
2. Turn the dial to set the hour.
3. Touch SELECT or START.
The “minutes” digits will flash in the display.
4. Turn the dial to set the minutes.
5. Touch SELECT or START to complete the setting.

To Cancel Clock:

1. Touch and hold SELECT for 5 seconds.
The clock-setting display will show.
2. Touch OFF/CANCEL.
The “:” will appear in the display.

The next time the clock is set, “12:00” will appear in the display when the clock-setting mode is entered.

Tones

Tones are audible signals that cannot be turned off, and their volume cannot be changed. These tones indicate the following:

One tone

- Reminder, repeat each minute after the end-of-cycle tones.

Two tones

- Hidden feature has been entered or exited.

Three tones

- Invalid entry
- End-of-cycle

Demo Mode

The Demo mode is ideal for learning how to use the microwave oven. When set, functions can be entered without actually heating. The microwave oven light will come on, the fan will run, and the turntable will rotate. When the microwave oven is turned on while in Demo mode, “no” and then “HEAT” will appear in the display.

To Turn On/Off: The microwave oven must be off. Open the door, then touch and hold COOK for 5 seconds. Two short tones will sound. Repeat to exit Demo mode.

Control Lock

The Control Lock shuts down the control panel keypads to avoid unintended use of the microwave oven.

When the control panel is locked, none of the keypads will function. If a keypad is touched, “LOC” will appear in the display and invalid entry tones will sound.

To Lock/Unlock Control: Before locking, make sure the microwave oven is OFF. Touch and hold OFF/CANCEL for more than three seconds until two tones sound. Repeat to unlock the keypads.

Cooling Fan

Depending on the length of the cooking cycle, the cooling fan may continue to run after that cycle has ended. This is normal and helps eliminate moisture that may accumulate inside the microwave oven before the door is opened.

While the fan is running, “COOL” will appear in the display. The fan will turn off automatically. New cooking functions may be started while “COOL” is still being displayed.

MICROWAVE OVEN USE

A magnetron in the microwave oven produces microwaves which reflect off the metal floor, walls, and ceiling and pass through the turntable and appropriate cookware to the food. Microwaves are attracted to and absorbed by fat, sugar, and water molecules in the food, causing them to move, producing friction and heat which cooks the food.

- To avoid damage to the microwave oven, do not lean on or allow children to swing on the microwave oven door.
 - To avoid damage to the microwave oven, do not operate microwave oven when it is empty.
 - Baby bottles and baby food jars should not be heated in microwave oven.
 - Clothes, flowers, fruit, herbs, wood, gourds, and paper, including brown paper bags and newspaper, should not be dried in the microwave oven.
 - Paraffin wax will not melt in the microwave oven because it does not absorb microwaves.
 - Use oven mitts or pot holders when removing containers from microwave oven.
 - Do not overcook potatoes. At the end of the recommended cook time, potatoes should be slightly firm. Let potatoes stand for 5 minutes. They will finish cooking while standing.
 - Do not cook or reheat whole eggs inside the shell. Steam buildup in whole eggs may cause them to burst, requiring significant cleanup of microwave oven cavity. Cover poached eggs and allow a standing time.
-

Food Characteristics

When microwave cooking, the amount, size and shape, starting temperature, composition, and density of the food affect cooking results.

Amount of Food

The more food heated at once, the longer the cook time needed. Check for doneness and add small increments of time if necessary.

Size and Shape

Smaller pieces of food will cook more quickly than larger pieces, and uniformly shaped foods cook more evenly than irregularly shaped food.

Starting Temperature

Room temperature foods will heat faster than refrigerated foods, and refrigerated foods will heat faster than frozen foods.

Composition and Density

Foods high in fat and sugar will reach a higher temperature and will heat faster than other foods. Heavy, dense foods, such as meat and potatoes, require a longer cook time than the same size of a light, porous food, such as cake.

Cooking Guidelines

Covering

Covering food helps retain moisture, shorten cook time, and reduce spattering. Use the lid supplied with cookware. If a lid is not available, wax paper, paper towels, or plastic wrap approved for microwave ovens may be used. Plastic wrap should be turned back at one corner to provide an opening to vent steam. Condensation on the door and cavity surfaces is normal during heavy cooking.

Stirring and Turning

Stirring and turning redistributes heat evenly to avoid overcooking the outer edges of food. Stir from outside to center. If possible, turn food over from bottom to top.

Arranging

If heating irregularly shaped or different-sized foods, arrange the thinner parts and smaller-sized items toward the center. If cooking several items of the same size and shape, place them in a ring pattern, leaving the center of the ring empty.

Piercing

Before heating, use a fork or small knife to pierce or prick foods that have a skin or membrane, such as potatoes, egg yolks, chicken livers, hot dogs, and sausage. Prick in several places to allow steam to vent.

Shielding

Use small, flat pieces of aluminum foil to shield the thin pieces of irregularly shaped foods, bones, and foods such as chicken wings, leg tips, and fish tails. See the “Aluminum Foil and Metal” section first.

Standing Time

Food will continue to cook by the natural conduction of heat even after the microwave cooking cycle ends. The length of standing time depends on the volume and density of the food.

Cookware and Dinnerware

Cookware and dinnerware must fit on the turntable. Always use oven mitts or pot holders when handling because any dish may become hot from heat transferred from the food. Do not use cookware and dinnerware with gold or silver trim. Use the following chart as a guide, then test before using.

| Material | Recommendations |
|--|--|
| Aluminum Foil, Metal | See the "Aluminum Foil and Metal" section. |
| Browning Dish | Bottom must be at least 3/16" (5 mm) above the turntable. Follow manufacturer's recommendations. |
| Ceramic Glass, Glass | Acceptable for use |
| China, Earthenware | Follow manufacturer's recommendations. |
| Melamine | Follow manufacturer's recommendations. |
| Paper: Towels, Dinnerware, Napkins | Use nonrecycled and those approved by the manufacturer for microwave oven use. |
| Plastic: Wraps, Bags, Covers, Dinnerware, Containers | Use those approved by the manufacturer for microwave oven use. |
| Pottery and Clay | Follow manufacturer's recommendations. |
| Silicone Bakeware | Follow manufacturer's recommendations. |
| Straw, Wicker, Wooden Containers | Do not use in microwave oven. |
| Wax Paper | Acceptable for use |

To Test Cookware or Dinnerware for Microwave Use:

1. Place cookware or dinnerware in microwave oven with 1 cup of water beside it. Each cup equals 8 oz (250 mL).
2. Cook at 100% cooking power for 1 minute.

Do not use cookware or dinnerware if it becomes hot and the water stays cool.

Aluminum Foil and Metal

Always use oven mitts or pot holders when removing dishes from the microwave oven.

Aluminum foil and some metal can be used in the microwave oven. If not used properly, arcing (a blue flash of light) can occur and cause damage to the microwave oven.

OK for Use

Racks and bakeware supplied with the microwave oven (on some models), aluminum foil for shielding, and approved meat thermometers may be used with the following guidelines:

- To avoid damage to the microwave oven, do not allow aluminum foil or metal to touch the inside cavity walls, ceiling, or floor.
- Always use the turntable.
- To avoid damage to the microwave oven, do not allow contact with another metal object during microwave cooking.

Do Not Use

Metal cookware and bakeware, gold, silver, pewter, non-approved meat thermometers, skewers, twist ties, foil liners such as sandwich wrappers, staples, and objects with gold or silver trim or a metallic glaze should not be used in the microwave oven.

Microwave Cooking Power

Many recipes for microwave cooking specify which cooking power to use by percent or name. For example, PL7 = 70% = Medium-High.

Use the following chart as a general guide for the suggested cooking power of specific foods.

| Percent/Name | Use |
|------------------------------|--|
| 100%, High (default setting) | Quick heating convenience foods and foods with high water content, such as soups, beverages, and most vegetables |
| 90% | Cooking small, tender pieces of meat, ground meat, poultry pieces, and fish fillets Heating cream soups |
| 80% | Heating rice, pasta or stirrable casseroles Cooking and heating foods that need a cook power lower than high, for example, whole fish and meat loaf |
| 70%, Medium-High | Reheating a single serving of food |
| 60% | Cooking sensitive foods such as cheese and egg dishes, pudding, and custards Cooking non-stirrable casseroles such as lasagna |
| 50%, Medium | Cooking ham, whole poultry, and pot roasts Simmering stews |
| 40% | Melting chocolate Heating bread, rolls, and pastries |
| 30%, Medium-Low, Defrost | Defrosting bread, fish, meats, poultry, and precooked foods |
| 20% | Softening butter, cheese, and ice cream |
| 10%, Low | Taking chill out of fruit |

Cook Time Set

Cook time may be set in the following increments, in minutes and seconds:

| Increment | Time Setting |
|-----------|--------------|
| 0:05 | 0:05-1:00 |
| 0:15 | 1:15-3:00 |
| 0:30 | 3:30-6:00 |
| 1:00 | 7:00-30:00 |
| 5:00 | 35:00-90:00 |

To Use:

1. Touch COOK TIME, then turn the dial to desired cook time
OR

touch COOK TIME repeatedly to increase cook time. See chart for time increments.

If cooking at 100% power, skip Step 2.

2. Touch COOK POWER, then turn the dial to the desired power level
OR

touch COOK POWER repeatedly to increase cook power.

3. Touch START.

The display will count down the cook time.

When the cycle ends, "END" will appear in the display and the end-of-cycle tones will sound, followed by reminder tones.

4. Touch OFF/CANCEL or open the door to clear the display and/or stop reminder tones.

The cook time may be changed at any time after touching START. The dial may be used to increase or reduce cook time. The Cook Time keypad will only add time.

Doneness

For most automatic cooking functions, the doneness of a particular food item can be adjusted by turning the dial. Increasing or decreasing the doneness adds time to or subtracts time from the cooking cycle.

For up to 20 seconds after cooking has started, turning the dial will change the doneness value. There are 5 settings: default, "2," "1," "-1," and "-2." The display shows "----" for the default setting.

Doneness cannot be adjusted for Defrost functions or for the Popcorn function.

Doneness cannot be adjusted for Boneless Chicken Breasts function.

Last value for doneness shown will be accepted after a few seconds, and the display will return to time count down; there is no need to press Start for a Doneness setting to be accepted

Meal Prep Cook

Times and cooking power have been preset for certain microwavable foods. Use the following chart as a guide.

| Food | No. | Quantity/Instructions |
|--------------------------|-----|---|
| Canned Vegetables | 1 | 1 to 4 cups (250 mL to 1 L): Each cup equals 8 oz (250 mL). Cover with plastic wrap and vent. Stir and let stand 2-3 minutes after cooking. |
| Cereal | 2 | 1 to 4 servings (28 g to 112 g): Each serving equals 1 oz (28 g). Use instant cereal. Follow instructions on package. Use microwave-safe bowls with high sides. |
| Boneless Chicken Breasts | 3 | 1 to 4 pieces (170 g to 680 g): Each piece equals 6 oz (170 g). Place in microwave-safe dish. Add 2 Tbsp (30 mL) water. Cover with plastic wrap and vent. Let stand in microwave oven for 3 minutes after cooking. |
| Fresh Vegetables | 4 | 1 to 4 cups (250 mL to 1 L): Each cup equals 8 oz (250 mL). Place in microwave-safe container. Add 2 to 4 Tbsp (30 to 60 mL) water. Cover with plastic wrap and vent. Stir and let stand 2-3 minutes after cooking. |
| Frozen Entrée | 5 | 10 or 20 oz (.28 kg or .57 kg) Remove from package. Loosen cover on 3 sides. If entree is not in microwave-safe container, place on plate, cover with plastic wrap, and vent. |
| Frozen Vegetables | 6 | 1 to 4 cups (250 mL to 1 L): Each cup equals 8 oz (250 mL). Remove from package. Place in microwave-safe container. Cover with plastic wrap and vent. Stir and let stand 2-3 minutes after cooking. |
| Rice | 7 | 0.5 to 2 cups (125 mL to 500 mL): Each cup equals 8 oz (250 mL) of dry rice. (Use medium or long grain rice.): Follow measurements on package for ingredient amounts. Place rice and liquid in microwave-safe dish. Cover with loose-fitting lid. Let stand 5 minutes after cooking, or until liquid is absorbed. Stir. |

To Use the Cook Control:

1. Touch COOK.
The display will show "1" for the first food type.
2. Turn the dial or repeatedly touch COOK to scroll through the food types until the number of the desired food type is displayed. See chart.
Wait 5 seconds or touch START or SELECT.
The display will prompt for amount or weight.
3. Turn the dial to the desired amount or weight.
4. Touch START.
Doneness may be adjusted within 20 seconds after touching START by turning the dial.
The display will count down the cook time.
When the cycle ends, "END" will appear in the display, and the end-of-cycle tones will sound, followed by reminder tones.
5. Touch OFF/CANCEL or open the door to clear the display and/or stop reminder tones.

Meal Prep Reheat

Times and cooking power have been preset for reheating specific food types. Use the following chart as a guide.

| Food | No. | Quantity/Instructions |
|--------------------------|-----|---|
| Baked Goods | 1 | 1 to 6 pieces (57 h to 342 g): Each piece equals 2 oz (57 g) Place on paper towel. |
| Beverage | 2 | 1 or 2 cups (250 mL to 500 mL): Each cup equals 8 oz (250 mL). Do not cover. The diameter of the cup's opening will affect how the liquid heats. Beverages in cups with smaller openings may heat faster. |
| Casserole (refrigerated) | 3 | 1 to 4 cups (250 mL to 1 L): Each cup equals 8 oz (250 mL). Place in microwave-safe container and cover with plastic wrap. Stir and let stand 2-3 minutes after reheating. |
| Pizza (refrigerated) | 4 | 1 to 3 pieces (85 g to 255g): Each piece is 3 oz (85g). |
| Sauce | 5 | 1 to 4 cups (250 mL to 1 L): Each cup equals 8 oz (250 mL). Place in microwave-safe container. Cover with plastic wrap and vent. Stir and let stand 2-3 minutes after reheating. |
| Soup | 6 | 1 to 4 cups (250 mL to 1 L): Each cup equals 8 oz (250 mL). Place in microwave-safe container. Cover with plastic wrap and vent. Stir and let stand 2-3 minutes after reheating. |

* For smaller rolls, 2 rolls may be counted as 1 piece.

To Use the Reheat Control:

1. Touch REHEAT.
The display will show "1" for the first food type.
2. Turn the dial or repeatedly touch REHEAT to scroll through the food types until the number of the desired food type is displayed. See chart.
Wait 5 seconds or touch START or SELECT.
The display will prompt for amount or weight.
3. Turn the dial to the desired amount or weight.
4. Touch START.
Doneness may be adjusted within 20 seconds after touching START by turning the dial.
The display will count down the reheat time.
When the cycle ends, "END" will appear in the display and the end-of-cycle tones will sound, followed by reminder tones.
5. Touch OFF/CANCEL or open the door to clear the display and/or stop reminder tones.

To Reheat Manually: Follow instructions in the "Cook Time Set" section and use 70% cooking power. See "Microwave Cooking Power" chart.

Meal Prep Defrost

The Automatic Defrost function can be used, or the microwave oven can be manually set to Defrost.

- Unwrap foods and remove lids (e.g. fruit juice containers) before defrosting.
- Shallow packages will defrost more quickly than deep blocks.
- Separate food pieces as soon as possible during or at the end of cycle for more even defrosting.
- Use small pieces of aluminum foil to shield parts of food such as chicken wings, leg tips and fish tails. See the "Aluminum Foil and Metal" section first.

The Automatic Defrost function should not be used for food left outside the freezer for more than 20 minutes and frozen ready made food.

Times and cooking power have been preset for defrosting certain food types. Use the following chart as a guide.

| Food | No. | Quantity/Instructions |
|--|-----|---|
| Bread (dinner rolls, muffins, buns, bread slices, bread loaf) | 1 | 0.1 to 2.0 lbs (0.04 to 0.91 kg): Place on paper towel. Do not cover. |
| Fish/Seafood (fillets, steaks, whole shellfish) | 2 | 0.2 to 4.4 lbs (0.09 to 2.0 kg): Remove wrap and place in microwave-safe baking dish Do not cover. |
| Meat (ground, steaks, roasts, stew, chops, ribs) | 3 | 0.2 to 6.6 lbs (0.09 to 3.0 kg): Remove wrap and place in microwave-safe baking dish Do not cover. |
| Poultry (whole chicken, chicken pieces, Cornish hens, turkey breast) | 4 | 0.2 to 6.6 lbs (0.09 to 3.0 kg): Remove wrap and place breast-side up in microwave-safe baking dish. Do not cover. |

To Use the Defrost Control:

1. Touch DEFROST.
The display will show "1" for the first food type.
2. Turn the dial or repeatedly touch DEFROST to scroll through the food types until the number of the desired food type is displayed. See chart.
Wait 5 seconds or touch START or SELECT.
The display will ask for weight.
3. Turn the dial to the desired weight.
4. Touch START.
The display will count down the defrost time.
When the cycle ends, "END" will appear in the display and the end-of-cycle tones will sound, followed by reminder tones.
5. Touch OFF/CANCEL or open the door to clear the display and/or stop reminder tones.

To Defrost Manually: Follow instructions in the "Cook Time Set" section, and use 30% cooking power. See "Microwave Cooking Power" chart.

Quick-Touch Cooking

NOTE: During Popcorn function, as with all microwave cooking functions, the microwave oven should be attended at all times. Listen for popping to slow to 1 pop every 1 or 2 seconds, then stop the cycle.

Use the following chart as a guide for the Quick-Touch keypads.

| Food | Serving Size | Instructions |
|--------------|--|---|
| Popcorn* | 3.0 or 3.5 oz (85 to 99 g) | Pop only one package at a time. |
| Baked Potato | 1 to 4 medium, 10 to 13 oz (283 to 369 g) each, similar in size | Pierce each one several times with a fork. Place on paper towel around turntable edges at least 1" (2.5 cm) apart. Let stand 5 minutes after cooking. |
| Meal Reheat | 1 serving (1 plate), 8 to 16 oz (227 to 454 g) | Place food on plate, cover with plastic wrap, and vent. |

*To avoid damage to the microwave oven, do not use regular paper bags or glassware. For best cooking results, do not try to pop unpopped kernels. Use fresh bags of popcorn for optimal results. Cooking results may vary by brand and fat content. For bag sizes not listed in this section, follow directions on package. If using a microwave popcorn popper, follow manufacturer's instructions.

To Use Baked Potato

1. Place item on turntable and close the door.
2. Touch BAKED POTATO.
3. Use dial to select the number of potatoes.
4. Press the Start control.

Doneness may be adjusted during the first 20 seconds of cooking by turning the dial. See the "Doneness" section.

The display will count down the cook time.

When the cycle ends, "END" will appear in the display, and the end-of-cycle tones will sound, followed by reminder

5. Touch OFF/CANCEL or open the door to clear the display and/or stop reminder tones.

To Use Meal Reheat:

1. Place food on the turntable, and close the door.
2. Touch MEAL REHEAT.
3. Press the START control.

The microwave will automatically turn on. Doneness may be adjusted during the first 20 seconds of cooking by turning the dial. See the "Doneness" section.

The display will count down the reheat time.

When the cycle ends, "END" will appear in the display, and the end-of-cycle tones will sound, followed by reminder tones.

4. Touch OFF/CANCEL or open the door to clear the display and/or stop reminder tones

To Use Popcorn:

1. Place popcorn bag on the turntable, correct side up, as indicated on the package.
2. Touch POPCORN.
The display will show "3.0." Turning the Settings dial will change the selection to "3.5."
3. Touch START.
4. The display will count down the popping time.
When the cycle ends, "END" will appear in the display, and the end-of-cycle tones will sound, followed by reminder tones.
5. Touch OFF/CANCEL or open the door to clear the display and/or stop reminder tones.

Keep Warm

WARNING

Food Poisoning Hazard

Do not let food sit in oven more than one hour before or after cooking.

Doing so can result in food poisoning or sickness.

Hot cooked food can be kept warm in the microwave oven. The Keep Warm function uses 10% cook power. Keep Warm can be used by itself or can be programmed to follow a cooking cycle.

- Cover plates of food.
- Cover foods that were covered while being cooked.
- For best results, do not cover baked goods such as pastries, pies, turnovers, etc.

To Use (for single cycle):

1. Touch KEEP WARM.
The display will show "60:00" which is the maximum default warming time.
2. Adjust the warming time, if desired, by turning the dial.
3. Touch START.
The display will count down the warming time and the Cook Time indicator will flash.
Warming time may be adjusted at any time during the Keep Warm cycle by turning the dial.
The 10% cook power cannot be changed during the Keep Warm cycle.
When the cycle ends, "END" will appear in the display, and the end-of-cycle tones will sound, followed by reminder tones.
4. Touch OFF/CANCEL or open the door to clear the display and/or stop reminder tones.

To Set at End of Cycle: During any cooking function, except Popcorn or Defrost, touch KEEP WARM. The Cook Time indicator will flash. After cooking is done, you can adjust warm time by turning the dial, if desired. When the current cooking cycle has ended, the end-of-cycle tones will sound, and then the Keep Warm cycle will automatically start. The Cook Time indicator will flash, and the display will count down the warming time. Warming time may be adjusted at any time during the countdown. At the end of the warming cycle, the end-of-cycle tones will sound, and the display will return to the time of day mode.

To Warm Manually: Follow instructions in "Cook Time Set" section and use 10% cooking power. See "Microwave Cooking Power" chart.

MICROWAVE OVEN CARE

General Cleaning

IMPORTANT: Before cleaning, make sure all controls are off and the microwave oven is cool. Always follow label instructions on cleaning products.

Soap, water, and a soft cloth or sponge are suggested unless otherwise noted.

MICROWAVE OVEN CAVITY

To avoid damage to the microwave oven cavity, do not use soap-filled scouring pads, abrasive cleaners, steel-wool pads, gritty washcloths, or some recycled paper towels.

To avoid damage to stainless steel models, rub in direction of grain.

The area where the microwave oven door and frame touch when closed should be kept clean.

Average soil

- Mild, nonabrasive soaps and detergents:
Rinse with clean water and dry with soft, lint-free cloth.

Heavy soil

- Mild, nonabrasive soaps and detergents:
Heat 1 cup or 8 oz (250 mL) of water for 2 to 5 minutes in microwave oven. Steam will soften soil. Rinse with clean water and dry with soft, lint-free cloth.

Odors

- Lemon juice or vinegar:
Heat 1 cup or 8 oz (250 mL) of water with 1 Tbsp (15 mL) of either lemon juice or vinegar for 2 to 5 minutes in microwave oven.

Microwave Inlet Cover

To avoid arcing and microwave oven damage, the microwave inlet cover (see the "Parts and Features" section) should be kept clean.

- Wipe with wet cloth.

MICROWAVE OVEN DOOR AND EXTERIOR

The area where the microwave oven door and frame touch when closed should be kept clean.

- Mild, nonabrasive soaps and detergents:
Rinse with clean water and dry with soft, lint-free cloth.
- Glass cleaner and paper towels or nonabrasive plastic scrubbing pad:
Apply glass cleaner to towel, not directly to surface.

Stainless Steel (on some models)

To avoid damage to microwave oven door and exterior, do not use soap-filled scouring pads, abrasive cleaners, steel-wool pads, gritty washcloths, or some paper towels. Rub in direction of grain.

- Stainless steel cleaner (not included):
See the "Assistance or Service" section to order.
- Vinegar for hard water spots

CONTROL PANEL

To avoid damage to the control panel, do not use abrasive cleaners, steel-wool pads, gritty washcloths, or some paper towels.

Make sure dial is pushed into its flush position.

- Glass cleaner and soft cloth or sponge:
Apply glass cleaner to soft cloth or sponge, not directly onto panel.

TURNTABLE

Replace turntable immediately after cleaning. Do not operate the microwave oven without the turntable in place.

- Mild cleanser and scouring pad
- Dishwasher

TROUBLESHOOTING

Try the solutions suggested here first in order to avoid the cost of an unnecessary service call.

| If you experience | Recommended Solutions |
|---|---|
| Nothing will operate | <p>Check the following:</p> <ul style="list-style-type: none">■ Household fuse or circuit breaker: If a household fuse has blown or a circuit breaker has tripped, replace the fuse or reset the circuit breaker. If the problem continues, call an electrician.■ Microwave wiring: See Installation Instructions provided with your microwave oven.■ Household power supply: The power source for this microwave oven uses an inverter, so it may be incompatible with a household power supply that also comes from an inverter. |
| Microwave oven will not operate | <p>Check the following:</p> <ul style="list-style-type: none">■ Magnetron: Try to heat 1 cup (250 mL) of cold water for 2 minutes at 100% cooking power. If water does not heat, try the steps in the bullets below. If microwave oven still does not operate, call for service. See “Assistance or Service” section.■ Door: Firmly close door. On some models, if a packaging spacer is attached to the inside of the door, remove it, then firmly close door. If a message about the door appears in the display, the door has been closed for 5 minutes or more without the microwave oven being started. This occurs to avoid unintended starting of the microwave oven. Open and close the door, then start the cycle.■ Control: Make sure control is set properly. Make sure Control Lock is Off. Make sure Demo mode (on some models) is Off. |
| Microwave oven makes humming noise | <ul style="list-style-type: none">■ This is normal and occurs when the power supply in the magnetron cycles on. |
| Microwave oven door looks wavy | <ul style="list-style-type: none">■ This is normal and will not affect performance. |
| Turntable will not operate | <p>Check the following:</p> <ul style="list-style-type: none">■ Turntable: Make sure turntable is correct-side up and is sitting securely on the turntable support. See the “Turntable” section.■ Turntable support: Remove turntable. Remove and clean turntable hub, support, and rollers. Replace hub, support, and turntable. Place 1 cup (250 mL) of water on the turntable, then restart microwave oven. If it still is not working, call for service. See the “Assistance or Service” section. Do not operate the microwave oven without turntable and turntable support working properly. |
| Turntable alternates rotation directions | <ul style="list-style-type: none">■ This is normal and depends on motor rotation at the beginning of the cycle. |
| Display shows messages | <ul style="list-style-type: none">■ Display is showing an “Oven Status” with a letter/number code and instruction to inform Ikea: The microwave oven has detected an internal problem. It has run a self-checking program and displayed the error. Call for service. See the “Warranty” section for contact information. |
| Display shows time countdown, but the microwave oven is not operating | <p>Check the following:</p> <ul style="list-style-type: none">■ Demo mode (one some models): See “Demo Mode” section. |
| Fan running slower than usual | <ul style="list-style-type: none">■ The microwave oven has been stored in a cold area: The fan will run slower until the microwave oven warms up to normal room temperature. |
| Cooking times seem too long | <p>Check the following:</p> <ul style="list-style-type: none">■ Cooking power: See the “Microwave Cooking Power” section.■ Amount of food: Larger amounts of food need longer cooking times.■ Voltage: Have a qualified electrician check the electrical system in the home. |
| Radio, TV, or cordless phone interference | <p>Check the following:</p> <ul style="list-style-type: none">■ Proximity: Move the receiver away from the microwave oven or adjust the radio or TV antenna. If the microwave oven is plugged into the same outlet, try a different outlet for the electronic device.■ Soil: Make sure the microwave oven door and sealing surfaces are clean.■ Frequency: Some 2.4 GHz-based cordless phones and home wireless networks may experience static or noise while microwave oven is ON. Use a corded phone, a different frequency cordless phone, or avoid using these items during microwave oven operation. |

ASSISTANCE OR SERVICE

Before calling for assistance or service, please check the “Troubleshooting” section. It may save you the cost of a service call. If you still need help, follow the instructions below.

When calling, please know the purchase date and the complete model and serial number of your appliance. This information will help us to better respond to your request.

If you need replacement parts

If you need to order replacement parts, we recommend that you use only factory specified parts. Factory specified parts will fit right and work right because they are made with the same precision used to build every new IKEA® appliance.

To locate factory specified parts in your area, call us or your nearest designated service center.

In the U.S.A.

Call the Whirlpool Customer eXperience Center toll free: **1-866-664-2449**.

Our consultants provide assistance with:

- Features and specifications on our full line of appliances.
- Installation information.
- Use and maintenance procedures.
- Accessory and repair parts sales.
- Specialized customer assistance (Spanish speaking, hearing impaired, limited vision, etc.).
- Referrals to local dealers, repair parts distributors, and service companies. Whirlpool designated service technicians are trained to fulfill the product warranty and provide after-warranty service anywhere in the United States.

To locate the Whirlpool designated service company in your area, you can also look in your telephone directory Yellow Pages.

For further assistance

If you need further assistance, you can write to Whirlpool Corporation with any questions or concerns at:

IKEA Brand Home Appliances
Customer eXperience Center
553 Benson Road
Benton Harbor, MI 49022-2692

Please include a daytime phone number in your correspondence.

In Canada

Call the Whirlpool Canada LP Customer eXperience Centre toll free: **1-866-664-2449**.

Our consultants provide assistance with:

- Features and specifications on our full line of appliances.
- Use and maintenance procedures.
- Accessory and repair parts sales.
- Referrals to local dealers, repair parts distributors, and service companies. Whirlpool Canada LP designated service technicians are trained to fulfill the product warranty and provide after-warranty service anywhere in Canada.

For further assistance

If you need further assistance, you can write to Whirlpool Canada LP with any questions or concerns at:

Customer eXperience Centre
Whirlpool Canada LP
200 – 6750 Century Ave.
Mississauga, Ontario L5N 0B7

Please include a daytime phone number in your correspondence.

Replacement Parts

Turntable
Part Number 8205676

Turntable Support and Rollers
Part Number 8205538

Cleaning Supplies

affresh® Stainless Steel
Cleaning Spray
Part Number W11042467

Turntable Hub
Part Number 8205539

affresh® Stainless Steel
Cleaning Wipes
Part Number W10539769

affresh® Stainless Steel
Cleaning Mousse
Part Number W11042466

IKEA MAJOR APPLIANCE WARRANTY

How long is the IKEA limited warranty valid?

This limited warranty is valid for five years from the date of purchase, when this major appliance is operated and maintained according to instructions attached to or furnished with the product, unless the appliance is named LAGAN in which case this limited warranty is valid for one year from the date of purchase. This limited warranty is valid only in the United States or Canada and applies only when the major appliance is used in the country in which it was purchased. Proof of original purchase date is required to obtain service under this limited warranty.

Which appliances are not covered by the IKEA five (5) year limited warranty?

For major appliances named “LAGAN,” this limited warranty is valid for one year from the date of purchase.

Who will execute the service?

This limited warranty is provided by Whirlpool Corporation or Whirlpool Canada LP (hereafter “Whirlpool”). Service must be provided by a Whirlpool designated service company.

What does this limited warranty cover?

The limited warranty will pay for factory specified parts and repair labor to correct defects in materials or workmanship that existed when the major appliance was purchased. The exceptions are specified under the headline “What is not covered under this limited warranty?”.

What will be done to correct the problem?

The designated service company will examine the product and decide, at its sole discretion, if it is covered under this limited warranty. If considered covered, the designated service company will then repair the defect. Your sole and exclusive remedy under this limited warranty shall be product repair as provided herein.

What is not covered under this limited warranty?

- Service calls to correct the installation of your major appliance, to instruct you on how to use your major appliance, to replace or repair house fuses, or to correct house wiring or plumbing.
- Service calls to repair or replace appliance light bulbs, air filters or water filters. Consumable parts are excluded from warranty coverage.
- Replacement parts or repair labor if this major appliance is used for other than normal, single-family household use or when it is used in a manner that is inconsistent to published user or operator instructions and/or installation instructions.
- Damage resulting from accident, alteration, misuse, abuse, fire, flood, acts of God, improper installation, installation not in accordance with electrical or plumbing codes, or use of consumables or cleaning products not approved for use.
- Cosmetic damage, including scratches, dents, chips or other damage to the finish of your major appliance, unless such damage results from defects in materials or workmanship and is reported within 30 days from the date of purchase.
- Any food loss or medicine loss due to refrigerator or freezer product failures.
- Pick up and delivery. This major appliance is intended to be repaired in your home.
- Repairs to parts or systems resulting from unauthorized modifications made to the appliance.
- Expenses for travel and transportation for product service if your major appliance is located in a remote area where service by an authorized servicer is not available.
- The removal and reinstallation of your major appliance if it is installed in an inaccessible location or is not installed in accordance with published installation instructions.
- Replacement parts or repair labor on major appliances with original model/serial numbers that have been removed, altered or cannot be easily determined.

The cost of repair or replacement under these excluded circumstances shall be borne by the customer.

Disclaimer of Implied Warranties

IMPLIED WARRANTIES, INCLUDING ANY IMPLIED WARRANTY OF MERCHANTABILITY OR IMPLIED WARRANTY OF FITNESS FOR A PARTICULAR PURPOSE, ARE LIMITED TO FIVE YEARS (ONE YEAR FOR MAJOR APPLIANCES NAMED “LAGAN”) OR THE SHORTEST PERIOD ALLOWED BY LAW. Some states and provinces do not allow limitations on the duration of implied warranties of merchantability or fitness, so this limitation may not apply to you. This warranty gives you specific legal rights, and you also may have other rights that vary from state to state or province to province.

Limitation of Remedies; Exclusion of Incidental and Consequential Damages

YOUR SOLE AND EXCLUSIVE REMEDY UNDER THIS LIMITED WARRANTY SHALL BE PRODUCT REPAIR AS PROVIDED HEREIN. WHIRLPOOL SHALL NOT BE LIABLE FOR INCIDENTAL OR CONSEQUENTIAL DAMAGES. Some states and provinces do not allow the exclusion or limitation of incidental or consequential damages, so these limitations and exclusions may not apply to you. This warranty gives you specific legal rights, and you also may have other rights that vary from state to state or province to province.

How to reach us if you need our service

If outside the 50 United States and Canada, contact your authorized IKEA retailer to determine if another warranty applies.

If you need service, please read the Installation Instructions and/or the “Troubleshooting” section of the Use & Care Guide before contacting us. If you need additional help, do not hesitate to contact us in the U.S.A. and Canada at **1-866-664-2449**.

Keep this book and your sales slip together for future reference. You must provide proof of purchase or installation date for in-warranty service.

Write down the following information about your major appliance to better help you obtain assistance or service if you ever need it. You will need to know your complete model number and serial number. You can find this information on the model and serial number label located on the product.

Dealer name _____

Address _____

Phone number _____

Model number _____

Serial number _____

Purchase date _____

W10909665A

©2017. All rights reserved.
Tous droits réservés.

Todos los derechos reservados.

® IKEA is a registered trademark of Inter-Ikea Systems B.V.

AFFRESH is a trademark of Whirlpool, U.S.A. used with permission.

® IKEA est une marque déposée de Inter-Ikea Systems B.V.

AFFRESH est une marque de commerce de Whirlpool, U.S.A. utilisée sous autorisation

® IKEA es una marca registrada de Inter-Ikea Systems B.V.

AFFRESH es una marca de comercio de Whirlpool, U.S.A. utilizada con permiso.