

CRAFTSMAN®

OPERATOR'S MANUAL | MANUAL DEL OPERARIO

Outdoor Portable Generator

Generador portátil para uso en exteriores

Not for
Reproduction

CMXGGAS030733

CMXGGAS030734

CMXGGAS030791



IF YOU HAVE ANY QUESTIONS OR COMMENTS, CONTACT US.

SI TIENE ALGUNA PREGUNTA O COMENTARIO, CONTÁCTENOS.

1-888-331-4569

WWW.CRAFTSMAN.COM

Copyright © 2018. Briggs & Stratton Corporation

Milwaukee, WI, USA. All rights reserved. Reservados todos los derechos.

CRAFTSMAN® is a registered trademark and CO Detection™ is a trademark of Stanley Black & Decker, Inc., used under license.

CRAFTSMAN® es una marca registrada y CO Detection™ es una marca de Stanley Black & Decker, Inc., usa abajo licencia.

Manual No. 8007440 Revision B

Equipment Description

Table of Contents







Equipment Description	2
Features and Controls	4
Operation	7
Maintenance	13
Storage	16
FCC/IC Compliance Statement	16
Troubleshooting/Specifications	17
Warranty	18

Register Your Product

To ensure prompt and complete warranty coverage, register your product online at www.Craftsman.com/registration.

Symbols and Meanings

Signal	Meaning
DANGER	Indicates a hazard which, if not avoided, <i>will</i> result in death or serious injury.
WARNING	Indicates a hazard which, if not avoided, <i>could</i> result in death or serious injury.
CAUTION	Indicates a hazard which, if not avoided, <i>could</i> result in minor or moderate injury.
NOTICE	Indicates information considered important, but not hazard-related.

Symbol	Name	Explanation
	Safety Alert Symbol	Indicates a potential personal injury hazard.
	Operator's Manual	Failure to follow warnings, instructions and operator's manual could result in death or serious injury.
	Toxic Fumes	Engine exhaust contains carbon monoxide, a poisonous gas that will kill you in minutes. You cannot smell it or see it.
	Fire	Fuel and its vapors are extremely flammable which could cause burns or fire resulting in death or serious injury. Engine exhaust could cause fire resulting in death or serious injury.
	Electric Shock	Generator could cause electrical shock resulting in death or serious injury.
	Hot Surface	Muffler could cause burns resulting in serious injury.



WARNING! This product can expose you to chemicals including gasoline engine exhaust, which is known to the State of California to cause cancer, and carbon monoxide, which is known to the State of California to cause birth defects or other reproductive harm. For more information go to www.P65Warnings.ca.gov.

Equipment Description



Read this manual carefully and become familiar with your outdoor generator. Know its applications, its limitations, and any hazards involved. Save these original instructions for future reference.

The outdoor generator is an engine-driven, revolving field, alternating current (AC) generator equipped with a voltage regulator. The generator is designed to supply electrical power for operating compatible electrical lighting, appliances, tools and motor loads. The voltage regulator within the generator is designed to automatically maintain output voltage level.

The portable generator can be used to power outdoor items using an extension cord or to restore home power using a transfer switch. A transfer switch is a separate device installed by a licensed electrician that allows the portable generator to be cord connected, using the locking receptacle, directly into your home's electrical system. Install a listed transfer switch as soon as possible if generator will be used to provide home power restoration.

Every effort has been made to ensure that the information in this manual is both accurate and current. However, the manufacturer reserves the right to change, alter or otherwise improve the generator and this documentation at any time without prior notice.

NOTICE If you have questions about intended use, contact an authorized service dealer. This equipment is designed to be used with Briggs & Stratton® authorized parts only.

System Ground

The generator has a system ground that connects the generator frame components to the ground terminals on the AC output receptacles. The system ground is connected to the AC neutral wire (the neutral is bonded to the generator frame).

Special Requirements

There may be Federal or State regulations, local codes, or ordinances that apply to the intended use of the generator. Please consult a qualified electrician, electrical inspector, or the local agency having jurisdiction.

This generator is not intended to be used at a construction site or similar activity as defined by NFPA 70-2017 (NEC) section 590.6.

To Restore Home Power Using a Listed Transfer Switch

Connections to your home's electrical system must use a listed* transfer switch installed by a licensed electrician. The connection must isolate the generator power from the utility power and comply with all applicable laws and electrical codes. Power your home with a 30 Amp transfer switch system.

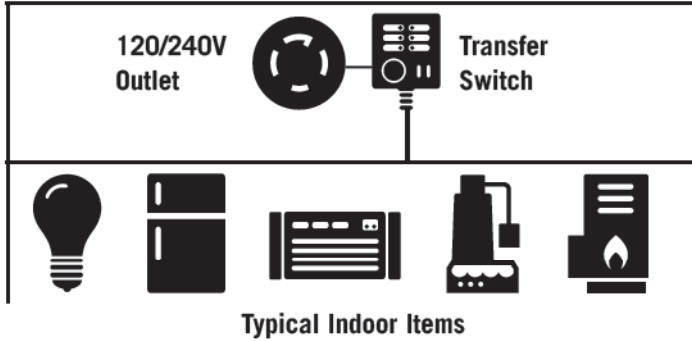

To Restore Power Using Extension Cords

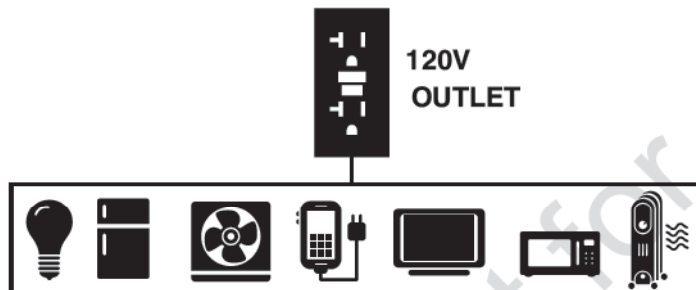

1. Only use grounded cords marked for outdoor use rated for your loads.

Total Amperage	Minimum Gauge, Outdoor Rated	
	Up to 50 FT (15 M)	Up to 100 FT (30 M)
Up to 13A	16	14
Up to 15A	14	12
Up to 20A	12	10
Up to 30A	10	8

2. Follow cord safety instructions.
3. Install carbon monoxide alarm(s).
4. When operating generator with extension cords, make sure it is located in an open, outdoor area, at least 20 ft. (6.1 m.) from occupied spaces with exhaust pointed away.
5. Extension cords running directly into home, powering indoor items IS NOT RECOMMENDED.



DANGER! Engine exhaust contains carbon monoxide, a poisonous gas that will kill you in minutes. You cannot smell it, see it, or taste it. Even if you do not smell exhaust fumes, you could still be exposed to carbon monoxide gas.

- Extension cords running directly into the home increase your risk of carbon monoxide poisoning through openings.
 - If an extension cord running directly into the home is used to power indoor items, the operator recognizes that this increases the risk of CO poisoning to people inside the home and assumes that risk.
6. Install a listed* transfer switch as soon as possible if generator will be used to provide home power restoration.

* Certified by a Nationally Recognized Testing Laboratory that the product complies to appropriate product safety test standards.

Equipment Description

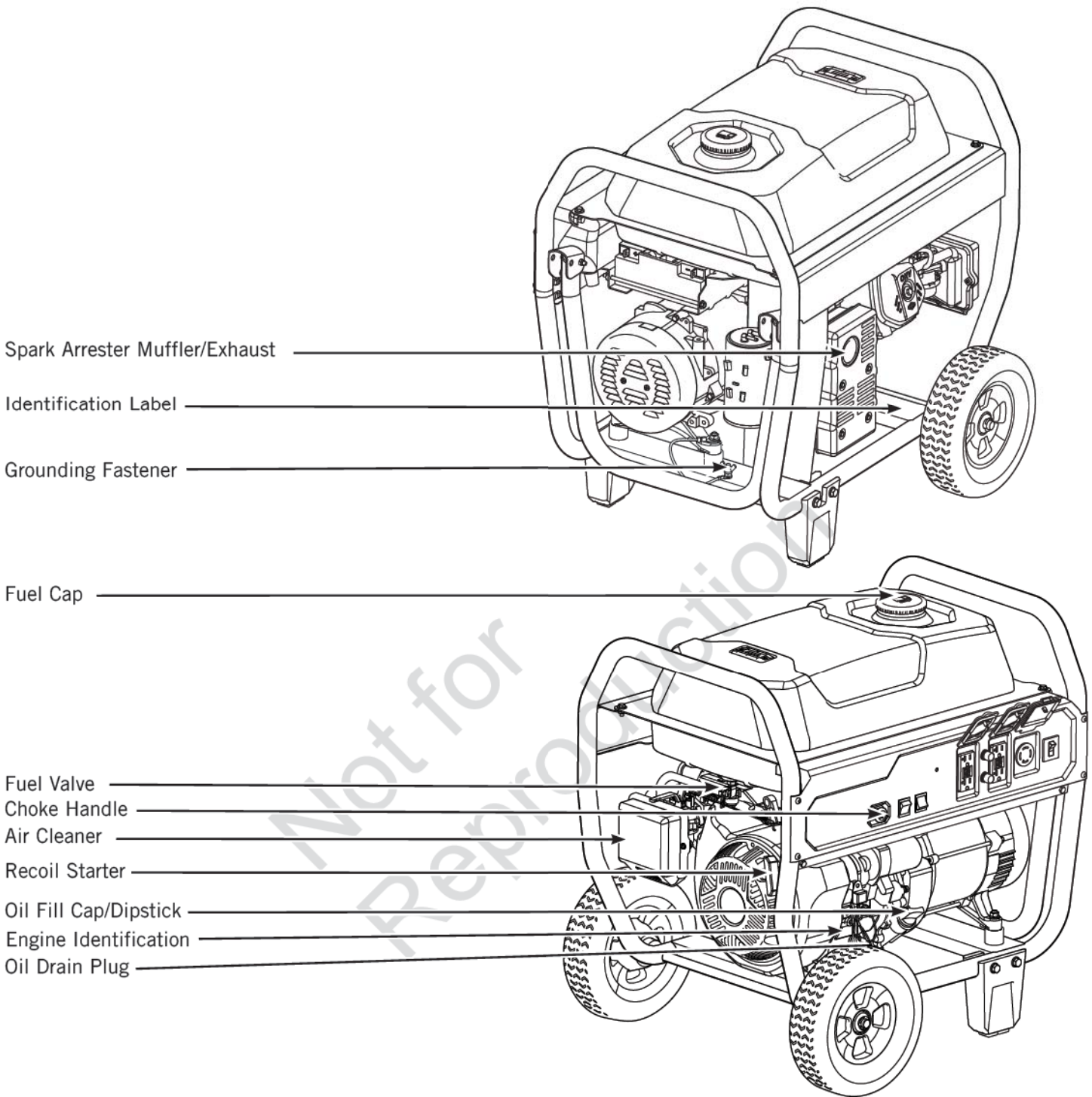

Air Cleaner — Filters engine intake air.

Choke Handle — Used when starting a cold engine.

Engine Identification — Provides model, type and code of engine.

Fuel Cap — Add unleaded fuel here.

Fuel Valve — Used to turn fuel supply on and off to engine.

Grounding Fastener — Consult your local agency having jurisdiction for grounding requirements in your area.

Identification Label — Provides model and serial number of generator.

Oil Drain Plug — Drain engine oil here.

Oil Fill Cap/Dipstick — Check and add engine oil here.

Recoil Starter — Used to start the engine manually.

Spark Arrester Muffler/Exhaust — Lowers engine noise and is equipped with a spark arrester screen.

Compare the illustrations with your generator to familiarize yourself with the locations of various controls and product warnings.

AUTOMATIC SHUTOFF—YOU MUST

Move generator to an open, outdoor area. Point exhaust away from homes. Don't run generator in enclosed areas (e.g. Not in house or garage).

 Move to fresh air and get medical help if sick, dizzy or weak.

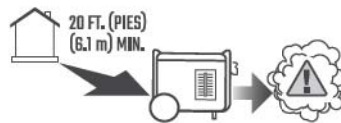

CORTE AUTOMÁTICO—DEBE REALIZAR LO SIGUIENTE

Mueva el generador a una zona abierta, al aire libre. Apunte el escape en la dirección opuesta de los casas. No arranque el generador en zonas cerradas (p. ej., dentro de una casa o garaje).

 Ubíquese en un lugar donde corra aire fresco y busque ayuda médica si se siente mal, mareado o débil.

80029735

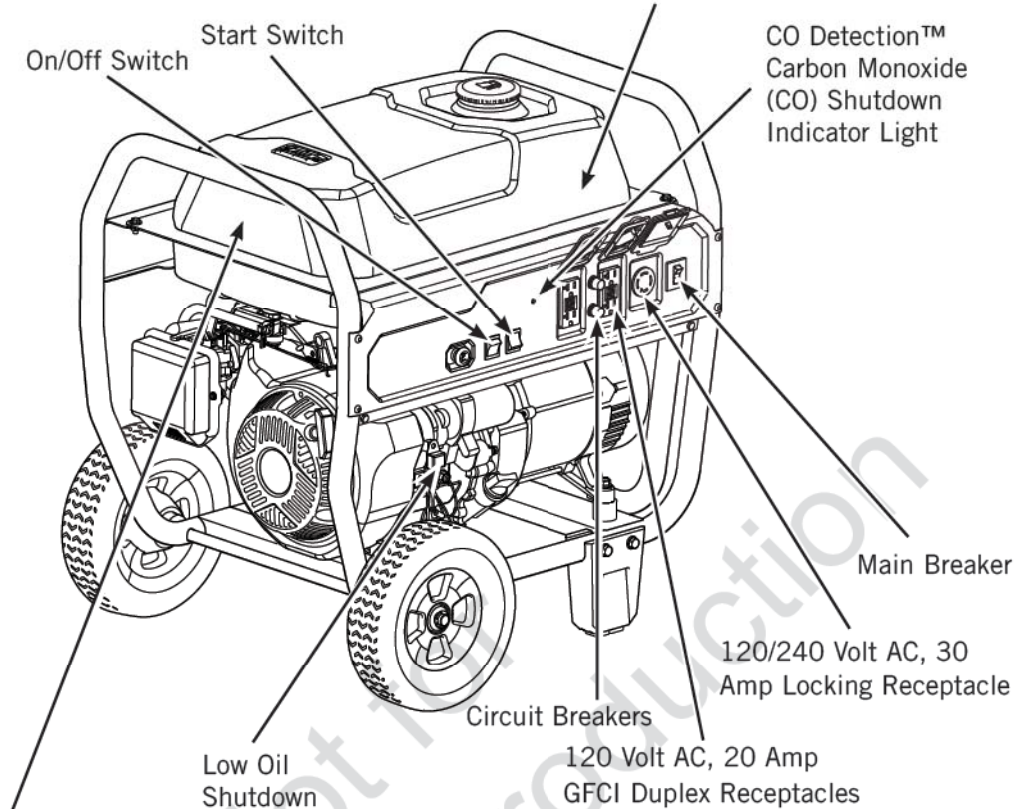

WARNING

Fire Hazard. Operation of this equipment may create sparks that can start fires around dry vegetation. A spark arrestor may be required. The operator should contact local fire agencies for laws or regulations relating to fire prevention requirements.



ADVERTENCIA

Peligro de incendio. La operación de este equipo podría ocasionar chispas que pueden comenzar incendios cerca de vegetación seca. Tal vez necesite un supresor de chispas. El operador debería contactar a las agencias locales de manejo del fuego para conocer las leyes y los reglamentos para la prevención de incendios.

80029721

120 Volt AC, 20 Amp, GFCI Duplex Receptacles — Used to supply 120 Volt AC, single phase, 60 Hz power for electrical lighting, appliance, tool and motor loads.

120/240 Volt AC, 30 Amp Locking Receptacle — Used to supply 120 / 240 Volt AC, single phase, 60 Hz power for electrical lighting, appliance, tool and motor loads.

Circuit Breakers — The 120 Volt AC, 20A GFCI duplex receptacles are provided with “push to reset” 20 Amp circuit breakers to protect the generator against electrical overload.

CO Detection Carbon Monoxide (CO) Shutdown Indicator Light — Indicates the engine shutdown due to carbon monoxide accumulation around the generator or a CO Detection system fault occurred.

Low Oil Shutdown — This unit is equipped with a low oil protection device. Oil must be at proper level for engine to run. If the engine oil drops below a preset level, an oil switch will stop the engine. Check oil level with dipstick.

Main Breaker — Protects generator against electrical overload. If breaker trips, it cuts power to all receptacles.

On/Off Switch — Set this switch to ON (I) before starting engine. Set switch to OFF (O) to shut off engine.

Start Switch — Push and hold in “Start” position for a maximum of 5 seconds during each start attempt, until engine starts.

Features and Controls



**Point engine exhaust away from all homes.
Apunte el escape del motor lejos de las casas.**

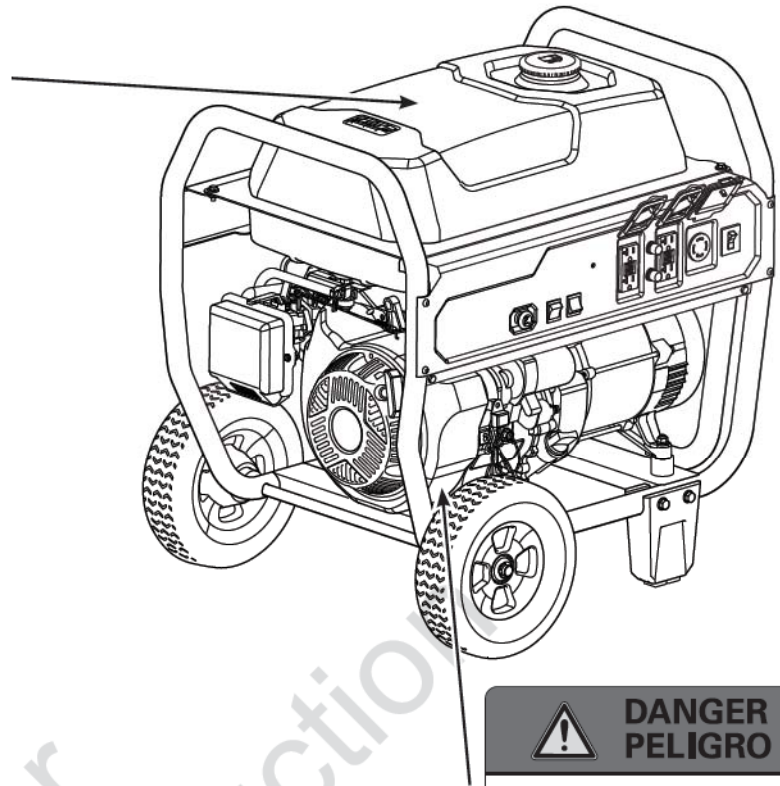

⚠ DANGER	
	Failure to follow warnings, instructions and operator's manual will result in death or serious injury.
	Tampering with CO Detection™ will cause Carbon Monoxide poisoning. Install Carbon Monoxide alarms inside home.
	Generator could cause electrical shock. <ul style="list-style-type: none"> • Do not run indoors to avoid wet conditions. • Do not run in rain or wet weather. • Transfer switch must be used when connecting to a home's electrical system
	Hot exhaust gases could cause fires. Keep at least 5 ft. (1.5 m) clearance from any combustibles or structures, including overhead.
⚠ PELIGRO	
	No obedecer las advertencias e instrucciones y el manual del operador provocará lesiones graves o la muerte.
	Manipular CO Detection™ causará envenenamiento por monóxido de carbono. Instale alarmas de monóxido de carbono en el interior de su casa.
	El generador podría causar una descarga eléctrica. <ul style="list-style-type: none"> • No opere en interiores para evitar condiciones de humedad. • No opere en la lluvia ni en clima húmedo. • Debe usarse el interruptor de transferencia cuando se conecta al sistema eléctrico de una casa.
	Los gases calientes del escape podrían causar un incendio. Deje un espacio libre de al menos 5 pies (1,5 m) de cualquier combustible o estructura, incluyendo por encima.



80078394

⚠ DANGER PELIGRO	
	Read and follow Operating Instructions before running or servicing engine. Lea y siga las Instrucciones de operación antes de operar o hacerle mantenimiento al motor.
	Engines emit carbon monoxide that will kill you. Operate only outdoors. Los motores emiten monóxido de carbono que lo matarán. Operar solo en exteriores.
⚠ WARNING ADVERTENCIA	
	Gasoline is flammable. Allow engine to cool at least 2 minutes before refueling. La gasolina es inflamable. Deje enfriar el motor al menos 2 minutos antes de agregar combustible.
	Muffler area temperature may exceed 150°F (65°C) Do not touch hot parts. La temperatura del área del silenciador puede exceder de 150°F (65°C). No toque las partes calientes.

383526

<p>⚠ WARNING</p> <p>Fuel is flammable which could cause burns resulting in death or serious injury.</p> <ul style="list-style-type: none"> • Turn engine off and let it cool at least 2 minutes before refueling. • Do not fill fuel above bottom lip. • Never add fuel to a hot or running generator. 		<p>⚠ ADVERTENCIA</p> <p>El combustible es inflamable, lo que podría causar quemaduras que ocasionen la lesiones graves o la muerte.</p> <ul style="list-style-type: none"> • Apague el motor y déjelo enfriar al menos 2 minutos antes de agregar combustible. • No llene el combustible por encima del borde inferior. • Nunca agregue combustible a un generador caliente o en operación.
--	---	---

80029440

<p>⚠ DANGER</p> <p>Using a generator indoors CAN KILL YOU IN MINUTES. Generator exhaust contains carbon monoxide. This is a poison you cannot see or smell.</p>		<p>⚠ PELIGRO</p> <p>El uso de un generador en un espacio interior PUEDE PROVOCAR LA MUERTE EN POCOS MINUTOS. Los gases de escape del generador contienen monóxido de carbono, un veneno invisible e inodoro.</p>	
			
<p>NEVER use inside a home or garage, EVEN IF doors and windows are open.</p>		<p>Only use OUTSIDE and far away from windows, doors, and vents.</p>	
		<p>NUNCA utilice un generador en el interior de una casa o un garaje, AUNQUE haya ventanas y puertas abiertas.</p> <p>Utilícelo solo en el EXTERIOR, alejado de ventanas, puertas y aberturas de ventilación.</p> <p style="text-align: right;">80029722</p>	

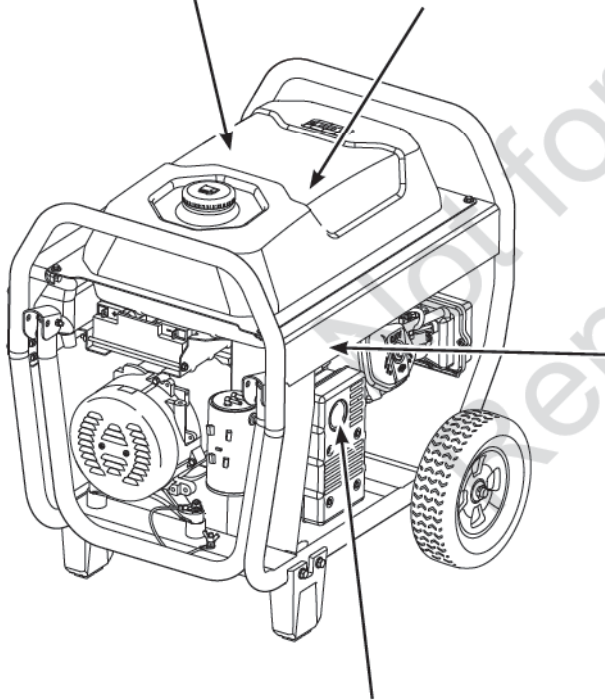

Exhaust/muffler
Point away from homes

<p>⚠ WARNING</p> <p>Muffler could cause burns resulting in serious injury.</p> <ul style="list-style-type: none"> • Do not touch hot parts • Avoid hot exhaust gases 		<p>⚠ ADVERTENCIA</p> <p>El silenciador podría causar quemaduras que ocasionen lesiones graves.</p> <ul style="list-style-type: none"> • No toque las partes calientes • Evite los gases calientes del escape
---	--	---

Operation

Operation

Step 1: Safe Location

Before starting the portable generator there are two equally important safety concerns regarding carbon monoxide poisoning and fire that must be addressed.

Operation Location to Reduce the Risk of Carbon Monoxide Poisoning

The engine exhaust of all fossil fuel burning equipment, such as a portable generator, contains carbon monoxide, a poisonous gas that will kill you in minutes. You cannot smell it, see it, or taste it. Even if you do not smell exhaust fumes, you could still be exposed to carbon monoxide gas.

By law in many jurisdictions it is required to have a carbon monoxide alarm in operating condition in your home. A carbon monoxide alarm is an electronic device that detects hazardous levels of carbon monoxide. When there is a buildup of carbon monoxide, the alarm will alert the occupants by flashing visual indicator light and alarm. Smoke alarms cannot detect carbon monoxide gas.

Carbon Monoxide Alarm(s)

Install carbon monoxide alarm inside your home. Without working carbon monoxide alarms, you will not realize you are getting sick and dying from carbon monoxide poisoning.

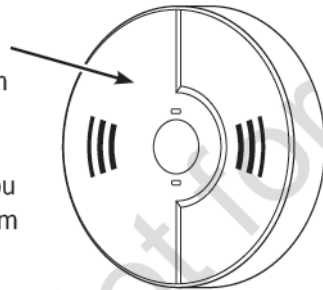

20 ft. (6.1 m) min.



Prevent Carbon Monoxide (CO) Poisoning

- Use outdoors at least 6.1 m (20 ft) from any home.
- Point exhaust away from all homes and occupied spaces.
- Install CO alarms inside your home.

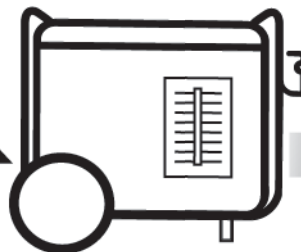

DANGER! Engine exhaust contains carbon monoxide, a poisonous gas that will kill you in minutes. You cannot smell it, see it, or taste it. Even if you do not smell exhaust fumes, you could still be exposed to carbon monoxide gas.

- Operate portable generator only outdoors, at least 20 ft. (6.1 m) from occupied spaces with exhaust pointed away to reduce the risk of carbon monoxide accumulating.
- Install battery-operated carbon monoxide alarms or plug-in carbon monoxide alarms with battery back-up according to the manufacturer's instructions. Smoke alarms cannot detect carbon monoxide gas.
- Do not run portable generator inside homes, garages, basements, crawlspaces, sheds, or other partially-enclosed spaces even if using fans or opening doors and windows for ventilation. Carbon monoxide can quickly build up in these spaces and can linger for hours, even after this product has shut off.

If you start to feel sick, dizzy, weak, or your homes carbon monoxide alarm sounds while using this product, get to fresh air right away. Call emergency services. You may have carbon monoxide poisoning.

To better educate yourself about all carbon monoxide risks, go to www.takeyourgeneratoroutside.com.

Operation Location to Reduce the Risk of Fire



WARNING! Exhaust heat/gases could ignite combustibles, structures or damage fuel tank causing a fire, resulting in death or serious injury.

- Portable generator must be at least 5 ft. (1.5 m) from any structure, overhang, trees, shrubs, or vegetation over 12 in. (30.5 cm) in height.

- Do not place portable generator under a deck or other type of structure that may confine airflow. Smoke alarm(s) must be installed and maintained indoors according to the manufacturer's instructions/recommendations.
- Carbon monoxide alarms cannot detect smoke.
- Do not place portable generator in manner other than shown.

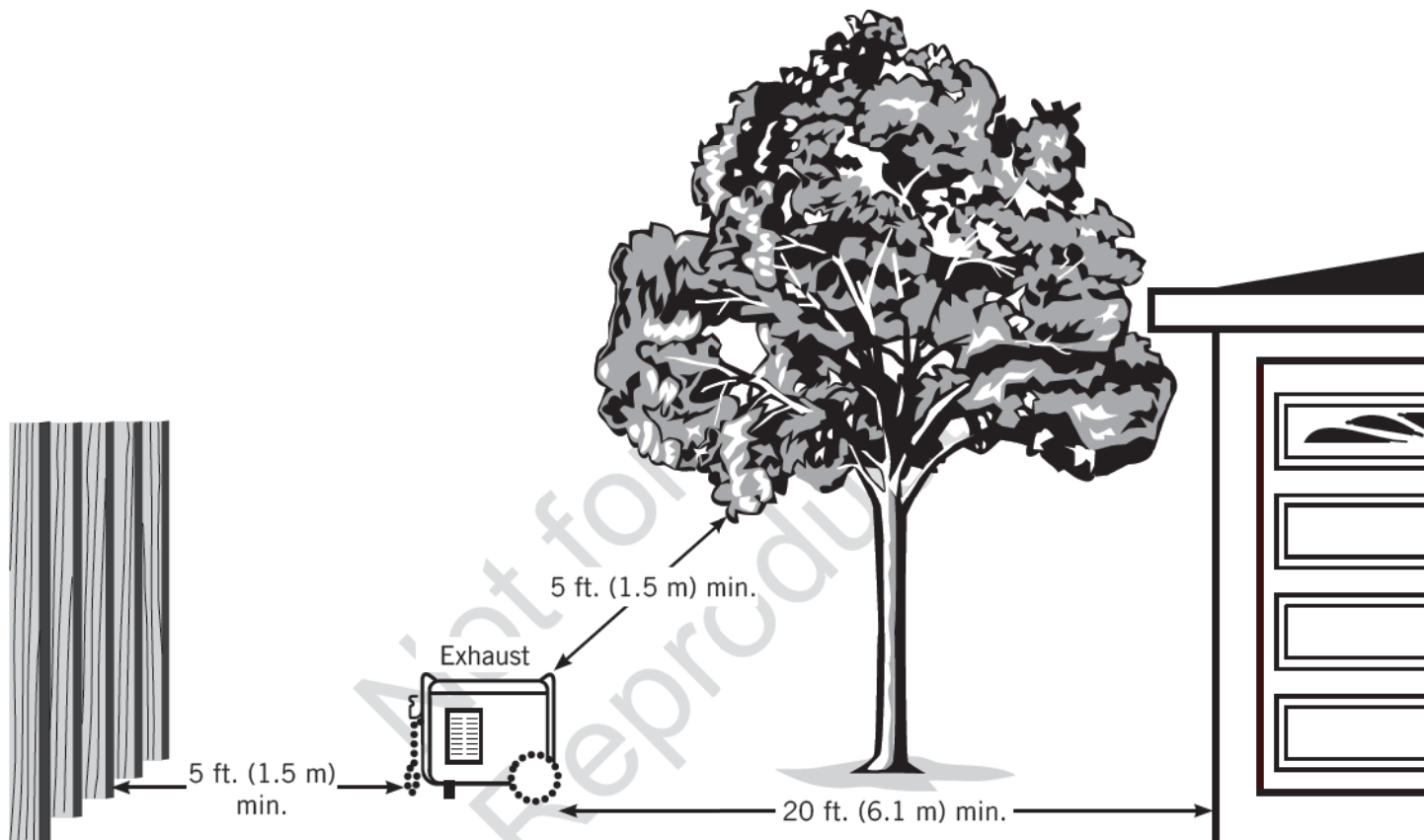

Operation

Step 2: Oil and Fuel

The generator engine is shipped from the factory filled with 10W30 oil. This allows for generator operation in a wide range of temperature and climate conditions. For checking/adding or changing oil see *Maintenance*.

Fuel must meet these requirements:

- Clean, fresh, unleaded fuel with a minimum of 87 octane.
- Gasoline with an ethanol content up to 10% is acceptable.

E10

E15

NOTICE Do not mix oil in fuel or modify engine to run on alternate fuels. Use of unapproved fuels could damage engine and will not be covered under warranty.

See *High Altitude* for 5,000 ft. and above.



WARNING! Fuel and its vapors are extremely flammable which could cause burns or fire resulting in death or serious injury.

- Do not refuel during operation.
 - Do not smoke during refueling.
 - Turn engine off and let it cool at least 2 minutes before removing fuel cap.
 - Fill fuel tank outdoors. Keep fuel away from sparks, open flames, pilot lights, heat, and other ignition sources. Check fuel lines, tank, cap and fittings frequently for cracks or leaks. Replace if necessary.
1. Slowly remove fuel cap to relieve pressure in tank.
 2. Slowly add unleaded fuel to fuel tank. Be careful not to fill above bottom lip. This allows adequate space for fuel expansion.

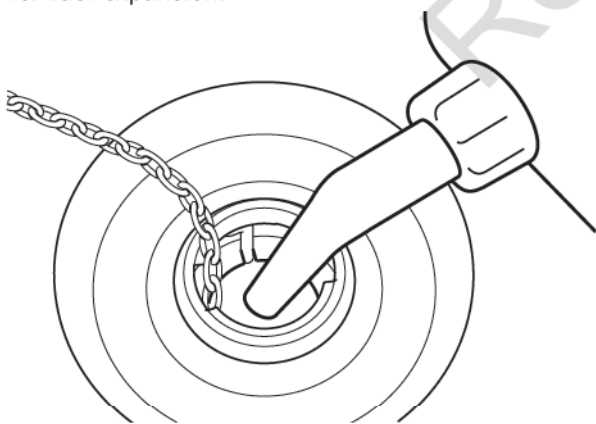

3. Install fuel cap and let any spilled fuel evaporate before starting engine.

High Altitude

At altitudes over 5,000 ft. (1524 m), a minimum 85 octane fuel is acceptable. To remain emissions compliant, high altitude adjustment is required. Operation without this adjustment will cause decreased performance, increased fuel consumption, and increased emissions.

See an authorized Briggs & Stratton dealer for high altitude adjustment information. Operation of the engine at altitudes below 2,500 ft. (762 m) with the high altitude kit is not recommended.

Transporting

When transporting equipment with a vehicle or trailer, turn fuel shutoff valve to off (O) position. Do not tip engine or equipment at an angle which causes fuel to spill.

Step 3: Generator Start Up

Disconnect all electrical loads from the generator. Use the following start instructions:

1. Make sure unit is outdoors on a level surface.

NOTICE Failure to operate the unit on a level surface may cause the unit to shut down.

2. Turn the fuel valve to the on (I) position.

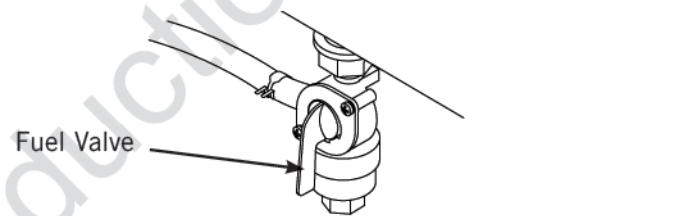

3. Set on/off switch to ON (I) position.

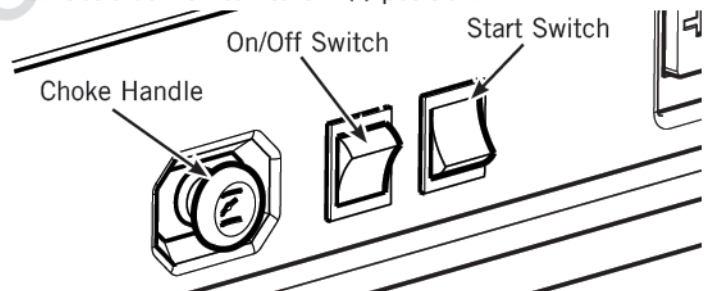

4. Pull choke handle out to CHOKE (I\|) position.

- 5A. **For electric starting**, push and hold (no more than 5 seconds) the start switch in "Start" position until generator starts.

NOTICE If battery is discharged, use manual starting instructions or charge battery with a battery charger designed specifically for AGM batteries and follow all charger instructions.

- 5B. **For manual starting**, grasp recoil handle and pull slowly until slight resistance is felt. Then pull rapidly to start engine.

- Gradually push choke handle in to run (I|I) position. If engine falters, move choke handle to half choke position until engine runs smoothly, and then push in to run (I|I) position.

NOTICE If engine starts but fails to run, see Low Oil Shutdown in *Features and Controls*.

Step 4: Connecting Electrical Loads

Using Extension Cords

Use only grounded extension cords marked for outdoor use rated for your loads. Follow cord safety instructions.



WARNING! Damaged or overloaded extension cords could overheat, arc, and burn resulting in death or serious injury.

NOTICE For best results when plugging into the 120 Volt GFCI receptacles, plug items to be powered in sequence as shown.

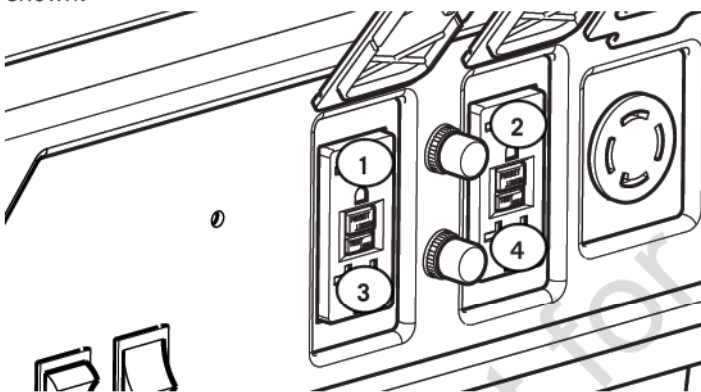

NOTICE For generator output required see *Generator Capacity*. Connect electrical loads in off position then turn on for operation.

120 Volt AC, 20 Amp, GFCI Duplex Receptacles

Use each receptacle to operate 120 Volt AC, single-phase, 60 Hz electrical loads requiring up to 2,400 Watts (2.4 kW) at 20 Amps of current.

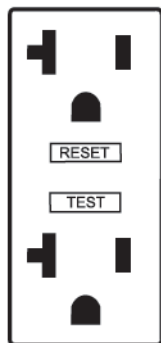

Ground Fault Protection

The duplex receptacles are equipped with Ground Fault Circuit Interrupter (GFCI) protection. The GFCI protects against electrical shock that may be caused if your body becomes a path which electricity travels to reach ground.

When protected by a GFCI, one may still feel a shock, but the GFCI is intended to cut current off quickly enough so that a person in normal health should not suffer any serious electrical injury.



WARNING! Generator voltage could cause electrical shock or burn resulting in death or serious injury. Contact with the hot and neutral conductor at the same time could cause electrical shock or burn, even if the circuit is GFCI protected.

Testing the GFCI

With the engine running, test your GFCI outlet prior to each use, as follows:

- Push the "Test" button. The "Reset" button should pop out, which should allow no power to reach the outlet.
- Press the "Reset" button firmly until it is fully in place and locks in that position. If the GFCI outlet does not reset properly, do not use the outlet. Call or take your generator to a local service center.
- If the GFCI trips by itself at any time, reset and test the outlet.

120/240 Volt AC, 30 Amp, Locking Receptacle

Use a NEMA L14-30 plug with this receptacle. Connect a 4-wire cord set rated for 250 Volt AC loads at 30 Amps. *The generator's locking receptacle is not protected by a GFCI.*

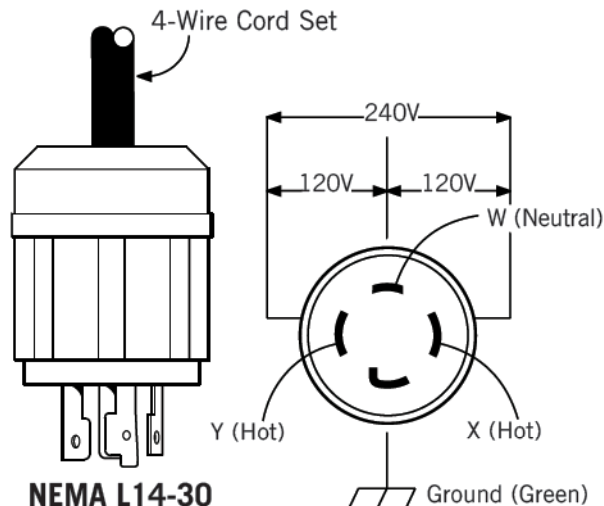

This receptacle powers 120/240 Volt AC, 60 Hz, single phase loads requiring up to 7,200 Watts of power (7.2 kW) at 30 Amps for 240 Volts or two independent 120 Volt loads at 30 Amps each.

Operation

Generator Capacity

To make sure your generator can supply enough running watts and starting watts for the items you will power at the same time, follow these three simple steps:

1. Select the items you will power at the same time. See following list for typical wattages.

Tool or Appliance	Running Watts*	Starting Watts**
Light Bulb - 75 Watt	75	-
Sump Pump - 1/3 HP	1140	2850
Refrigerator/Freezer	550	1350
Water Well Pump - 1/3 HP	575	1440
Window AC - 10,000 BTU	1000	2100
Furnace Fan Blower - 1/2 HP	800	2350
Microwave Oven - 1000 Watt	1000	-
Plasma Television - 50"	500	-
Laptop	250	-
Garage Door Opener - 1/2 HP	300	500

* Typical wattages listed are approximate only. Check tool or appliance for actual wattage.

** The momentary electrical current the generator can provide to start electric motors, per Briggs & Stratton standard 628K. It does not represent the power required to continuously run electrical loads. It is the maximum current that can momentarily be supplied when starting a motor, multiplied by the generator's rated voltage.

2. Total the running watts. This is the amount of power your generator must produce to keep your items running. See following example:

Example

Tool or Appliance	Running Watts	Starting Watts
Window AC - 10000 BTU	1000	2100
Refrigerator/Freezer	550	1350
Plasma Television	500	—
Light (75 Watts)	75	—
	2125 Total Running Watts	2100 Highest Starting Watts

Total running watts = 2125

Highest starting watts = 2100

Total generator watts required = 4225

3. Estimate the starting watts you will need. Because not all motors start at the same time, total starting wattage can be estimated by adding only the item with the highest additional starting watts requirements to the total running watts from step 2.

Power Management

To manage generator power, sequentially add loads as follows:

1. With nothing connected to generator, start the engine outdoors.
2. Plug in and turn on the first load, preferably the largest load you have.
3. Permit the generator output to stabilize (engine runs smoothly and attached device operates properly).
4. Plug in and turn on the next load.
5. Again, permit the generator to stabilize.
6. Repeat steps 4 and 5 for each additional load.

Never add more loads than the generator capacity. Take special care to consider starting watts in generator capacity.

CO Detection

Carbon Monoxide (CO) Shutdown System

CO Detection automatically shuts down the engine when harmful levels of carbon monoxide accumulate around the generator or a CO Detection fault occurs. After shutdown, the CO Detection indicator light will blink for at least five minutes per the chart below.

CO Detection DOES NOT replace carbon monoxide alarms. Install battery-powered carbon monoxide alarm(s) in your home. Don't run generator in enclosed areas.

Color/Pattern	Description
Red • • •	Carbon monoxide accumulated around generator. Move generator to an open, outdoor area 20 ft. (6.1 m) from occupied spaces with exhaust pointed away. Automatic shutoff is an indication generator was improperly located. If you start to feel sick, dizzy, weak, or your homes carbon monoxide alarm sounds while using this product, get to fresh air right away. Call emergency services. You may have carbon monoxide poisoning.
Blue • • •	CO Detection fault occurred*. See Briggs & Stratton authorized service dealer.

*Blue light will blink for five seconds at the startup of generator to show CO Detection functioning properly.

Step 5: Generator Shutdown

1. Turn off and unplug all electrical loads from generator panel receptacles. Never stop engine with electrical devices plugged in and turned on.
2. Let engine run at no-load for one minute to stabilize internal temperatures of engine and generator.
3. Push on/off switch to off (O) position.
4. Move fuel valve to off (O) position.

Maintenance

Maintenance Schedule

Follow the hourly or calendar intervals, whichever occurs first. More frequent service is required when operating in adverse conditions noted below.

First 5 Hours
<ul style="list-style-type: none"> • Change engine oil
Every 8 Hours or Daily
<ul style="list-style-type: none"> • Clean debris • Check engine oil level
Every 25 Hours or Yearly
<ul style="list-style-type: none"> • Clean engine air filter¹
Every 100 Hours or Yearly
<ul style="list-style-type: none"> • Change engine oil¹
Yearly
<ul style="list-style-type: none"> • Replace engine air filter¹ • Service fuel valve • Service spark plug • Inspect muffler and spark arrester • Clean cooling system^{1,2}

¹ Service more often under dirty or dusty conditions.

² See any authorized dealer for service.

General Recommendations

Regular maintenance will improve the performance and extend the life of the generator. See any authorized dealer for service.

The generator's warranty does not cover items that have been subjected to operator abuse or negligence. To receive full value from the warranty, the operator must maintain the generator as instructed in this manual.

All service and adjustments should be made at least once each season. A new spark plug and clean air filter assure proper fuel-air mixture and help your engine run better and last longer. Follow requirements in *Maintenance Schedule*.

Emissions Control

Maintenance, replacement, or repair of the emissions control devices and systems may be performed by any non-road engine repair establishment or individual. However, to obtain "no charge" emissions control service, the work must be performed by a factory authorized dealer. See *Emissions Warranty*.

Cleaning

Daily or before use, look around and underneath the generator for signs of oil or fuel leaks. Clean any accumulated debris. Keep area around muffler free from any debris.

- Use a soft bristle brush to loosen caked on dirt or oil.
- Use a damp cloth to wipe exterior surfaces clean.

NOTICE Improper treatment of generator could damage it and shorten its life. Do not expose generator to excessive moisture, dust, dirt, or corrosive vapors. Do not insert any objects through cooling slots.

Fuel Valve Maintenance

The fuel valve is equipped with a fuel sediment cup, screen, and o-ring that need to be cleaned.

1. Move fuel valve to off (O) position.
2. Remove sediment cup from fuel valve. Remove o-ring and screen from fuel valve.

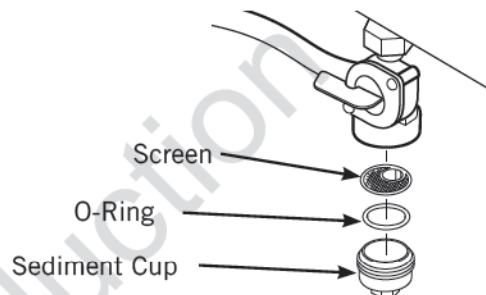

3. Wash sediment cup, o-ring, and screen in a nonflammable solvent. Dry them thoroughly.
4. Place screen and o-ring into fuel valve. Install sediment cup and tighten securely.
5. Move fuel valve to on (I) position, and check for leaks. Replace fuel valve if there is any leakage.

Maintenance

Engine Maintenance

Oil Recommendations

We recommend the use of Briggs & Stratton Warranty Certified oils for best performance. Other high-quality detergent oils are acceptable if classified for service SF or higher. Do not use special additives. See *Common Service Parts*.

Outdoor temperatures determine the proper oil viscosity for the engine. Use the chart to select the best viscosity for the outdoor temperature range expected.

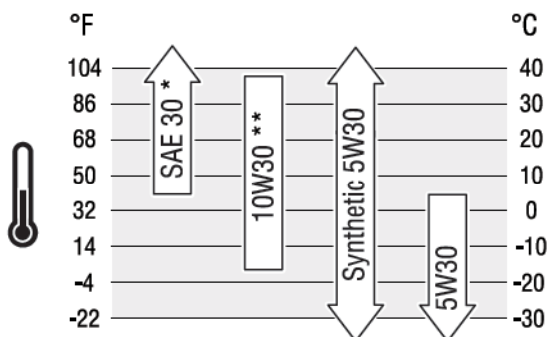

* Below 4°C (40°F) the use of SAE 30 will result in hard starting.

** Above 27°C (80°F) the use of 10W30 may cause increased oil consumption. Check oil level more frequently.

Checking/Adding Engine Oil

Oil level should be checked prior to each use or at least every 8 hours of operation. Keep oil level maintained.

1. Make sure generator is on a level surface.
2. Clean area around oil fill, remove dipstick and wipe with clean cloth. Replace dipstick. Remove and check oil level.

NOTICE Do not screw in dipstick when checking oil level.

3. Verify oil is at full mark on dipstick. Replace and tighten dipstick.

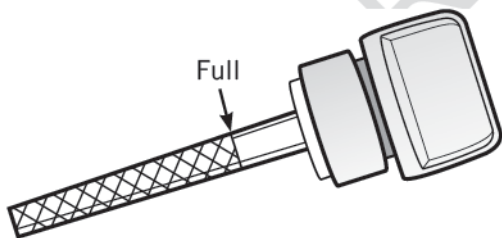

4. If needed, slowly pour oil into oil fill opening to the full mark on dipstick. Do not overfill.

NOTICE Overfilling with oil could cause the engine to not start, or hard starting.

- Do not overfill.
 - If over the full mark on dipstick, drain oil to reduce oil level to full mark on dipstick.
5. Replace and tighten dipstick.

NOTICE Do not attempt to crank or start engine before it has been properly serviced with recommended oil. This could result in an engine failure.

CAUTION Avoid prolonged or repeated skin contact with used motor oil. Used motor oil has been shown to cause skin cancer in certain laboratory animals. Thoroughly wash exposed areas with soap and water.



KEEP OUT OF REACH OF CHILDREN. DON'T POLLUTE. CONSERVE RESOURCES. RETURN USED OIL TO COLLECTION CENTERS.

Changing Engine Oil

If you are using your generator under extremely dirty or dusty conditions, or in extremely hot weather, change the oil more often.

Change the oil while the engine is still warm from running, as follows:

1. Make sure unit is on a level surface.
2. Remove oil drain plug and drain oil completely into a suitable container.

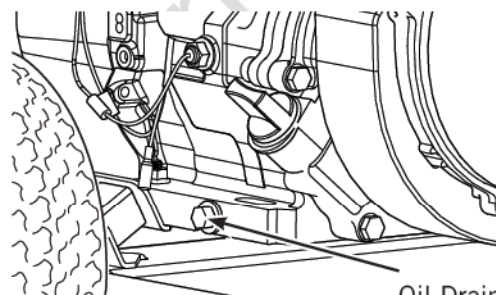

Oil Drain Plug

3. Reinstall oil drain plug and tighten securely. Remove dipstick.
4. Slowly pour recommended oil (about 36 oz. (1.0 l)) into oil fill opening. Pause to permit oil to settle. Fill to Full mark on dipstick.
5. Wipe dipstick clean each time oil level is checked. Do not overfill.
6. Reinstall dipstick. Tighten cap securely.
7. Wipe up any spilled oil.

Service Air Cleaner



WARNING! Fuel and its vapors are extremely flammable which could cause burns or fire resulting in death or serious injury.

- Do not start and run engine with air filter removed.

Your engine will not run properly and may be damaged if you run it with a dirty air filter. Clean or replace more often if operating under dusty or dirty conditions.

1. Loosen screws and remove air cleaner cover.

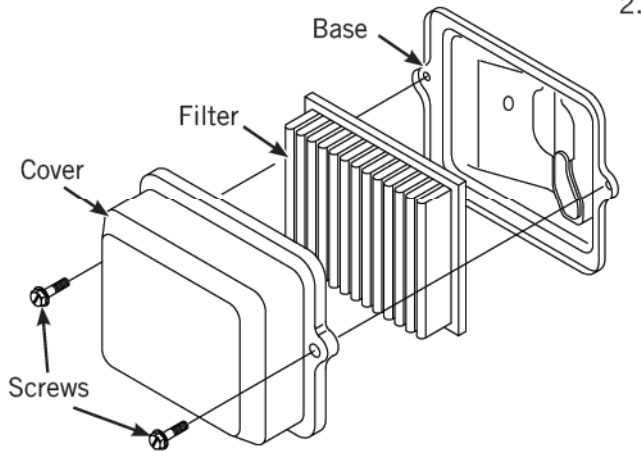

Carefully remove cartridge from base.

3. Install clean (or new) air cleaner assembly inside cover. Dispose of old filter properly.

NOTICE If the filter is excessively dirty, replace with a new filter. See *Common Service Parts*.

4. Assemble air cleaner cover onto base and tighten screws.

Service Spark Plug

Changing the spark plug will help your engine to start easier and run better.

1. Clean area around spark plug.
2. Remove and inspect spark plug.
3. Replace spark plug if electrodes are pitted, burned or porcelain is cracked. Use the recommended replacement spark plug. See *Common Service Parts*.
4. Check electrode gap with wire feeler gauge and reset spark plug gap to recommended gap if necessary (see *Specifications*).

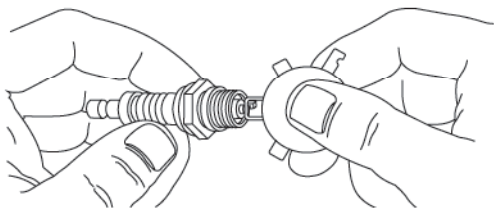

5. Install spark plug and tighten firmly.

Inspect Muffler and Spark Arrester

The engine exhaust muffler has a spark arrester screen. Inspect the muffler for cracks, corrosion, or other damage. Inspect spark arrester screen for damage or carbon blockage. Clean if carbon blockage is found using brush and commercial solvent or replace if damaged.



WARNING! Contact with muffler area could cause burns resulting in serious injury.

- Allow equipment to cool before servicing.
- It is a violation of California Public Resource Code, Section 4442, to use or operate the engine on any forest-covered, brush-covered, or grass-covered land unless the exhaust system is equipped with a spark arrester, as defined in Section 4442, maintained in effective working order. Other states or federal jurisdictions may have similar laws, reference Federal Regulation 36 CFR Part 261.52.

Replace spark arrester as follows:

1. Remove four screws that connect heat shield to muffler.

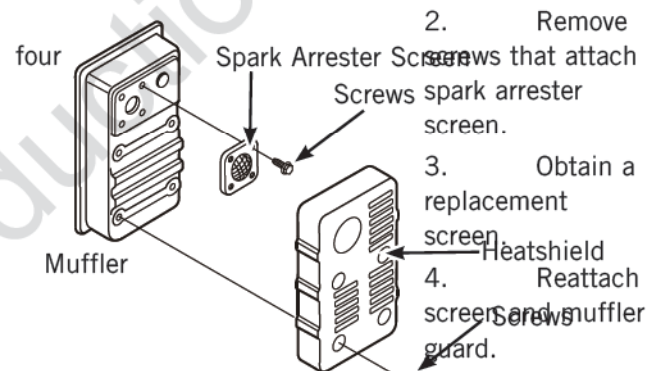

Common

Air Cleaner 491588 or 5043
 Spark Plug 795615
 Engine Oil Bottle 100028
 Synthetic Oil Bottle 100074
 Fuel Stabilizer 100120 or 100117
 Contact an authorized service dealer or
 BRIGGSandSTRATTON.com for a full list of parts and
 diagrams.

Service Parts

Storage

If storing the unit for more than 30 days, use the following guidelines to prepare it for storage.

Long Term Storage Instructions

1. Clean the generator as outlined in *Cleaning*.
2. Change engine oil while engine is still warm, drain oil from crankcase. Refill with recommended grade. See *Changing Engine Oil*.
3. Treat or drain fuel from generator as fuel can become stale when stored over 30 days.

Stale fuel causes acid and gum deposits to form in the fuel system or on essential carburetor parts. To keep fuel fresh, use Briggs & Stratton® Advanced Formula Fuel Treatment & Stabilizer, available wherever Briggs & Stratton genuine service parts are sold. See *Common Service Parts*.

There is no need to drain gasoline from the engine if a fuel stabilizer is added according to instructions. Run the engine for 2 minutes to circulate the stabilizer throughout the fuel system before storage.

If gasoline in the engine has not been treated with a fuel stabilizer, it must be drained into an approved container. Then run the engine until it stops from lack of fuel. The use of a fuel stabilizer in the storage container is recommended to maintain freshness.



WARNING! Fuel and its vapors are extremely flammable and explosive which could cause burns, fire or explosion resulting in death or serious injury.

- When storing fuel or equipment with fuel in tank, store away from furnaces, stoves, water heaters, clothes dryers or other appliances that have pilot light or other ignition source because they could ignite fuel vapors.
 - When draining fuel, turn generator engine off and let it cool at least 2 minutes before removing fuel cap. Loosen cap slowly to relieve pressure in tank. Drain fuel tank outdoors. Keep fuel away from sparks, open flames, pilot lights, heat, and other ignition sources.
 - Check fuel lines, tank, cap and fittings frequently for cracks or leaks. Replace if necessary.
4. Store generator in clean, dry area and cover with a suitable protective cover that does not retain moisture.



WARNING! Storage covers could cause a fire resulting in death or serious injury.

- Do not place a storage cover over a hot or running generator. Let equipment cool for a sufficient time before placing the cover on the equipment.

FCC/IC Compliance Statement

FCC Part 15 Information to User

Pursuant to part 15.21 of the FCC Rules, you are cautioned that changes or modifications to transceiver not expressly approved by Briggs & Stratton could void your authority to operate the portable generator.

This device complies with part 15 of the FCC Rules. Operation is subject to the following two conditions: (1) This device may not cause harmful interference, and (2) this device must accept any interference received, including interference that may cause undesired operation.

This equipment has been tested and found to comply with the limits for a Class B digital device, pursuant to part 15 of the FCC Rules. These limits are designed to provide reasonable protection against harmful interference in a residential installation. This equipment generates, uses and can radiate radio frequency energy and, if not installed and used in accordance with the instructions, may cause harmful interference to radio communications. However, there is no guarantee that interference will not occur in a particular installation. If this equipment does cause harmful interference to radio or television reception, which can be determined by turning the equipment off and on, the user is encouraged to try to correct the interference by one or more of the following measures:

- Reorient or relocate the receiving antenna.
- Increase the separation between the equipment and receiver.
- Connect the equipment into an outlet on a circuit different from that to which the receiver is connected.
- Consult the dealer or an experienced radio/TV technician for help.

Problem	Cause	Correction
Engine is running, but no AC output is available.	<ol style="list-style-type: none"> 1. One of the circuit breakers is open. 2. Poor connection or defective cord set. 3. Connected device is bad. 4. GFCI tripped. 	<ol style="list-style-type: none"> 1. Reset circuit breaker. 2. Check and repair. 3. Connect another device that is in good condition. 4. Reset GFCI.
Engine runs well at no-load but “bogs down” when loads are connected.	<ol style="list-style-type: none"> 1. Generator is overloaded. 	<ol style="list-style-type: none"> 1. See <i>Generator Capacity</i>.
Engine will not start; starts and runs rough or shuts down when running.	<ol style="list-style-type: none"> 1. Engine switch set to off (O) position. 2. Fuel valve is in off (O) position. 3. Low oil level. 4. Dirty air cleaner. 5. Out of fuel. 6. Spark plug wire not connected to spark plug. 7. Flooded with fuel. 	<ol style="list-style-type: none"> 1. Set switch to on (I) position. 2. Turn fuel valve to on (I) position. 3. Fill crankcase to proper level or place generator on level surface. 4. Clean or replace air cleaner. 5. Fill fuel tank. 6. Connect wire to spark plug. 7. Wait 5 minutes and re-crank engine.
Engine shuts down and CO Detection LED blinks red (•• ••).	<ol style="list-style-type: none"> 1. Generator improperly located. 	<ol style="list-style-type: none"> 1. Move generator to an open, outdoor area. See <i>CO Detection Carbon Monoxide (CO) Shutdown System</i>.

For all other issues, see a Briggs & Stratton authorized dealer.

Specifications

Models CMXGGAS030733 & CMXGGAS030734

Rated Wattage*	7,000 Watts
Starting Wattage**	10,500 Watts
AC Current at 240 Volts	29.1 Amps
AC Current at 120 Volts	58.3 Amps

Model CMXGGAS030791

Rated Wattage*	8,000 Watts
Starting Wattage**	11,500 Watts
AC Current at 240 Volts	33.3 Amps
AC Current at 120 Volts	66.6 Amps

Power Ratings: The gross power rating for individual gasoline engine models is labeled in accordance with SAE (Society of Automotive Engineers) code J1940 Small Engine Power & Torque Rating Procedure, and is rated in accordance with SAE J1995. Torque values are derived at 2600 RPM for those engines with “rpm” called out on the label and 3060 RPM for all others; horsepower values are derived at 3600 RPM. The gross power curves can be viewed at www.BRIGGSandSTRATTON.COM. Net power values are taken with exhaust and air cleaner installed whereas gross power values are collected without these attachments. Actual gross engine power will be higher than net engine power and is affected by, among other things, ambient operating conditions and engine-to-engine variability. Given the wide array of products on which engines are placed, the gasoline engine may not develop the rated gross power when used in a given piece of power equipment. This difference is due to a variety of factors including, but not limited to, the variety of engine components (air cleaner, exhaust, charging, cooling, carburetor, fuel pump, etc.), application limitations, ambient operating conditions (temperature, humidity, altitude), and engine-to engine variability. Due to manufacturing and capacity limitations, Briggs & Stratton may substitute an engine of higher rated power for this engine.

* Generator per PGMA (Portable Generator Manufacturers' Association) standard ANSI/PGMA G300-2018, Safety and Performance of Portable Generators.

** Per Briggs & Stratton 628K

Common Specifications

Frequency	60 Hz at 3600 rpm
Phase	Single Phase
Displacement	25.63 cu. in. (420 cc)
Spark Plug Gap	0.030 in. (0.76 mm)
Fuel Capacity	8.5 U.S. Gallons (32.2 Liters)
Oil Capacity	36 Ounces (1.0 Liters)

CRAFTSMAN WARRANTY POLICY

LIMITED WARRANTY

Craftsman® is a registered trademark of Stanley Black & Decker Inc. and is used under license to Briggs & Stratton. Briggs & Stratton warrants that, during the warranty period specified below, it will repair or replace, free of charge, any part that is defective in material or workmanship or both. Transportation charges on product submitted for repair or replacement under this warranty must be borne by purchaser. This warranty is effective for and is subject to the time periods and conditions stated below. For warranty service, find the nearest Authorized Service Dealer in our dealer locator map at BRIGGSANDSTRATTON.COM. The purchaser must contact the Authorized Service Dealer, and then make the product available to the Authorized Service Dealer for inspection and testing.

There is no other express warranty. Implied warranties, including those of merchantability and fitness for a particular purpose, are limited to the warranty period listed below, or to the extent permitted by law. Liability for incidental or consequential damages are excluded to the extent exclusion is permitted by law. Some states or countries do not allow limitations on how long an implied warranty lasts, and some states or countries do not allow the exclusion or limitation of incidental or consequential damages, so the above limitation and exclusion may not apply to you. This warranty gives you specific legal rights and you may also have other rights which vary from state to state or country to country.**

WARRANTY PERIOD

Item	Consumer Use	Commercial Use
Equipment	24 months	12 months
Engine*	24 months	12 months
Chassis [§]	36 months	12 months
Battery	3 months	None

* Applies to Briggs & Stratton engines only. Warranty coverage of non-Briggs & Stratton engines is provided by that engine manufacturer. Emissions-related components are covered by the Emissions Warranty Statement.

[§] Chassis is defined as the frame and any part welded to the frame

** In Australia - Our goods come with guarantees that cannot be excluded under the Australian Consumer Law. You are entitled to a replacement or refund for a major failure and for compensation for any other reasonably foreseeable loss or damage. You are also entitled to have the goods repaired or replaced if the goods fail to be of acceptable quality and the failure does not amount to a major failure. For warranty service, find the nearest Authorized Service Dealer in our dealer locator map at BRIGGSANDSTRATTON.COM, or by calling 1300 274 447, or by emailing or writing to salesenquires@briggsandstratton.com.au, Briggs & Stratton Australia Pty Ltd, 1 Moorebank Avenue, NSW, Australia, 2170.

The warranty period begins on the date of purchase by the first retail or commercial consumer. "Consumer use" means personal residential household use by a retail consumer. "Commercial use" means all other uses, including use for commercial, income producing or rental purposes. Once a product has experienced commercial use, it shall thereafter be considered as a commercial use product for purposes of this warranty.

Save your proof of purchase receipt. If you do not provide proof of the initial purchase date at the time warranty service is requested, the manufacturing date of the product will be used to determine the warranty period. Product registration is not required to obtain warranty service on Briggs & Stratton products.

ABOUT YOUR WARRANTY

Warranty service is available only through Briggs & Stratton Authorized Service Dealers. This warranty covers only defects in materials or workmanship. It does not cover damage caused by improper use or abuse, improper maintenance or repair, normal wear and tear, or stale or unapproved fuel.

Improper Use and Abuse - The proper, intended use of this product is described in the Operator's Manual. Using the product in a way not described in the Operator's Manual or using the product after it has been damaged will not be covered under this warranty. Warranty coverage will also not be provided if the serial number on the product has been removed or the product has been altered or modified in any way, or if the product has evidence of abuse such as impact damage or water/chemical corrosion damage.

Improper Maintenance or Repair - This product must be maintained according to the procedures and schedules provided in the Operator's Manual, and serviced or repaired using genuine Briggs & Stratton parts or equivalent. Damage caused by lack of maintenance or use of non-original parts is not covered by warranty.

Normal Wear and Tear - Like most mechanical devices, your unit is subject to wear even when properly maintained. This warranty does not cover repairs when normal use has exhausted the life of a part or the equipment. Maintenance and wear items such as filters, belts, cutting blades, and brake pads (except engine brake pads) are not covered by warranty due to wear characteristics alone, unless the cause is due to defects in material or workmanship.

Stale or Unapproved Fuel - In order to function correctly, this product requires fresh fuel that conforms to the criteria specified in the Operator's Manual. Engine or equipment damage caused by stale fuel or the use of unapproved fuels (such as E15 or E85 ethanol blends) is not covered by warranty.

Other Exclusions - This warranty excludes damage due to accident, abuse, modifications, alterations, improper servicing, freezing or chemical deterioration. Attachments or accessories that were not originally packaged with the product are also excluded. There is no warranty coverage on equipment used for primary power in place of utility power or on equipment used in life support applications. This warranty does not include used, reconditioned, second-hand, or demonstration equipment or engines. This warranty also excludes failures due to acts of God and other force majeure events beyond the manufacturer's control.

80030189EN Rev A

Not for
Reproduction

CRAFTSMAN®

Outdoor Portable Generator

Generador portátil para uso en exteriores

Not for
Reproduction

WWW.CRAFTSMAN.COM

1-888-331-4569

CMXGGAS030733

CMXGGAS030734

CMXGGAS030791

CRAFTSMAN® is a registered trademark of Stanley Black & Decker, Inc., used under license.
CRAFTSMAN® es una marca registrada de Stanley Black & Decker, Inc., usa abajo licencia.

**Briggs & Stratton Corporation
Milwaukee, Wisconsin, 53201-0702 U.S.A.**