

Use & Care Guide
Manual de Uso y Cuidado
English / Español

Kenmore®

Liquid Propane Gas Grill

Parrilla a gas de propano líquido

Model/Modelo: 146.22124910

Item / Artículo: 640-01998717-1

P/N 40600050Z
Sears Brands Management Corporation
Hoffman Estates, IL 60179 U.S.A.
www.kenmore.com
www.sears.com
www.kmart.com



DANGER

If you smell gas:

1. Shut off gas to the appliance.
2. Extinguish any open flame.
3. Open lid.
4. If odor continues, keep away from the appliance and immediately call your gas supplier or your fire department

WARNING

1. Do not store or use gasoline or other flammable liquids or vapors in the vicinity of this or any other appliance.
2. An LP cylinder not connected for use shall not be stored in the vicinity of this or any other appliance.

Call Grill Service Center For Help And Parts
 If you have questions or need assistance during assembly, please call **1-888-287-0735**. You will be speaking to a representative of the grill manufacturer and not a Sears employee. To order new parts call Sears at **1-844-553-6667**.

Product Record
 IMPORTANT: Fill out the product record information below.

Model Number _____

Serial Number _____
 See rating label on grill for serial number.

Date Purchased _____

CAUTION

For residential use only. Do not use for commercial cooking.

- Installation Safety Precautions**
- Please read this User's Manual in its entirety before using the grill.
 - Failure to follow the provided instruction can result in seriously bodily injury and/or property damage.
 - Some parts of this grill may have sharp edges. Please wear suitable protective gloves.
 - Use grill, as purchased, only with LP (propane) gas and the regulator/valve assembly supplied.
 - Grill installation must conform with local codes, or in their absence of local codes, with either the National Fuel Gas Code, ANSI Z223.1/ NFPA 54, Natural Gas and Propane Installation Code, CSA B149.1, or Propane Storage and Handling Code, B149.2, or the Standard for Recreational Vehicles, ANSI A 119.2/NFPA 1192, and CSA Z240 RV Series, Recreational Vehicle Code, as applicable.
 - All electrical accessories (such as rotisserie) must be electrically grounded in accordance with local codes, or National Electrical Code, ANSI / NFPA 70 or Canadian Electrical Code, CSA C22.1. Keep any electrical cords and/or fuel supply hoses away from any hot surfaces.
 - This grill is safety certified for use in the United States and/or Canada only. Do not modify for use in any other location. Modification will result in a safety hazard.

IMPORTANT: This grill is intended for outdoor use only and is not intended to be installed in or on recreational vehicles or boats.

NOTE TO INSTALLER: Leave this User's Manual with the customer after delivery and/or installation.

NOTE TO CONSUMER: Leave this User's Manual in a convenient place for future reference.

Safety Symbols
 The symbols and boxes shown below explain what each heading means. Read and follow all of the messages found throughout the manual

DANGER

DANGER: Indicates an imminently hazardous situation which, if not avoided, will result in death or serious injury.

WARNING

WARNING: Indicates an potentially hazardous situation which, if not avoided, could result in death or serious injury.

CAUTION

CAUTION: Indicates a potentially hazardous situation or unsafe practice which, if not avoided, may result in minor or moderate injury.

TABLE OF CONTENTS

For Your Safety 2
Grill Service Center 2
Product Record Information 2
Installation Safety Precautions 2
Safety Symbols 2
Kenmore Grill Warranty 4
Use and Care 5-11
Parts List 12
Parts Diagram 13
Before Assembly 14-17
Assembly 18-28
Troubleshooting 29-31

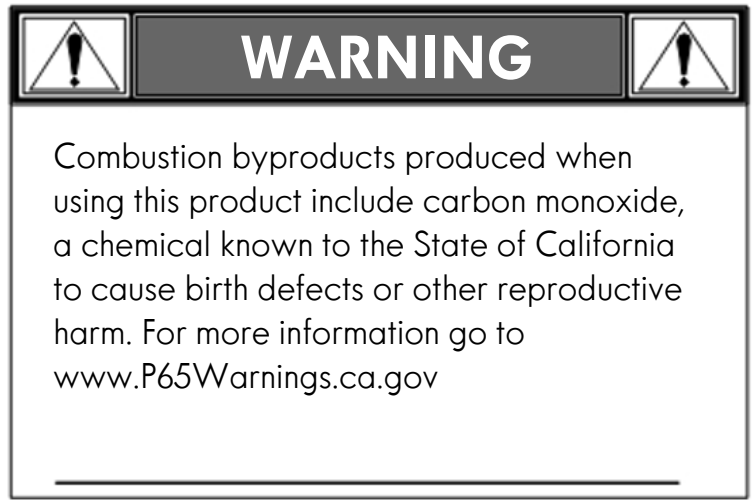

WARRANTY

KENMORE GRILL WARRANTY

KENMORE LIMITED WARRANTY

WITH PROOF OF SALE, the following warranty coverage applies when this appliance is correctly installed, operated and maintained according to all supplied instructions.

FOR ONE YEAR from the date of sale this appliance is warranted against defects in material or workmanship. A defective appliance will receive free repair. If the appliance cannot be repaired it will be replaced free of charge.

FOR FIVE YEARS from the date of sale, any stainless steel burner that rusts through or burns through will be replaced free of charge.* If rust through or burn through occurs within the first year, a new burner will be installed at no charge. If rust through or burn through occurs after the first year, a new burner will be supplied but not installed at no charge. You are responsible for the labor cost of burner installation after the first year from the date of sale. *Rust-through or burn-through must be verified by a Sears authorized service representative.

For warranty coverage details to obtain free repair or replacement, visit the web page: www.kenmore.com/warranty

All warranty coverage excludes ignitor batteries and grill part paint loss, discoloration or surface rusting, which are either expendable parts that can wear out from normal use within the warranty period, or are conditions that can be the result of normal use, accident or improper maintenance.

All warranty coverage is void if this appliance is ever used for other than private household purposes.

This warranty covers ONLY defects in material and workmanship, and will NOT pay for:

1. Expendable items that can wear out from normal use within the warranty period, including but not limited to batteries, screw-in base light bulbs and surface coatings or finishes.
2. A service technician to clean or maintain this appliance, or to instruct the user in correct appliance installation, operation and maintenance.
3. Service calls to correct appliance installation not performed by Sears authorized service agents, or to repair problems with house fuses, circuit breakers, house wiring, and plumbing or gas supply systems resulting from such installation.
4. Damage to or failure of this appliance resulting from installation not performed by Sears authorized service agents, including installation that was not in accord with electrical, gas or plumbing codes.
5. Damage to or failure of this appliance, including discoloration or surface rust, if it is not correctly operated and maintained according to all supplied instructions.
6. Damage to or failure of this appliance, including discoloration or surface rust, resulting from accident, alteration, abuse, misuse or use for other than its intended purpose.
7. Damage to or failure of this appliance, including discoloration or surface rust, caused by the use of detergents, cleaners, chemicals or utensils other than those recommended in all instructions supplied with the product.
8. Damage to or failure of this appliance resulting from natural or other catastrophe, such as flood, fire or storm.
9. Damage to or failure of parts or systems resulting from unauthorized modifications made to this appliance.
10. Service to an appliance if the model and serial plate is missing, altered, or cannot easily be determined to have the appropriate certification logo.

Disclaimer of implied warranties; limitation of remedies

Customer's sole and exclusive remedy under this limited warranty shall be product repair or replacement as provided herein. Implied warranties, including warranties of merchantability or fitness for a particular purpose, are limited to one year on the appliance and five years on the burners, or the shortest period allowed by law. Seller shall not be liable for incidental or consequential damages. Some states and provinces do not allow the exclusion or limitation of incidental or consequential damages, or limitation on the duration of implied warranties of merchantability or fitness, so these exclusions or limitations may not apply to you.

This warranty applies only while this appliance is used in the United States.

This warranty gives you specific legal rights, and you may also have other rights which vary from state to state.

Sears Brands Management Corporation, Hoffman Estates, IL 60179

USE AND CARE



DANGER



- **NEVER** store a spare LP cylinder under or near the appliance or in an enclosed area.



- **Never fill a cylinder beyond 80% full.**
- **If the information in the two points above is not followed exactly, a fire causing death or serious injury may occur.**
- **An overfilled or improperly stored cylinder is a hazard due to possible gas release from the safety relief valve. This could cause an intense fire with risk of property damage, serious injury or death.**
- **If you see, smell or hear gas escaping, immediately get away from the LP cylinder and appliance and call your fire department.**

LP Tank Removal, Transport And Storage

- Turn OFF all control knobs and LP tank valve. Turn coupling nut counterclockwise by hand only - do not use tools to disconnect. Lift LP tank wire upward off of LP tank collar, then lift LP tank up and off of support bracket. Install safety cap onto LP tank valve. Always use cap and strap supplied with valve.

Failure to use safety cap as directed may result in serious personal injury and/or property damage.

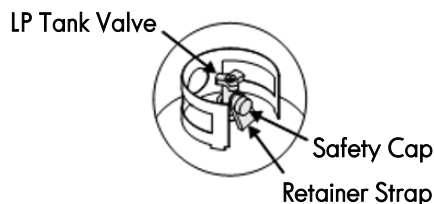

- A disconnected LP tank in storage or being transported must have a safety cap installed (as shown). Do not store an LP tank in enclosed spaces such as a carport, garage, porch, covered patio or other building. Never leave an LP tank inside a vehicle which may become overheated by the sun.
- Do not store an LP tank in an area where children play.

LP Cylinder

- The LP cylinder used with your grill must meet the following requirements:
- Use LP cylinders only with these required measurements: 12" (30.5cm) (diameter) x 18" (45.7 cm) (tall) with 20 lb. (9 kg.) Capacity maximum.
- LP cylinders must be constructed and marked in accordance with specifications for LP cylinders of the U.S. Department of Transportation (DOT) or for Canada, CAN/CSA-B339, cylinders, spheres and tubes for transportation of dangerous goods. Transport Canada (TC). See LP cylinder collar for marking.
- LP cylinder valve must have:
 - Type 1 outlet compatible with regulator or grill.
 - Safety relief valve.
 - UL listed Overfill Protection Device (OPD). This OPD safety feature is identified by a unique triangular hand wheel. **Use only LP cylinders equipped with this type of valve.**
- LP cylinder must be arranged for vapor withdrawal and include collar to protect LP cylinder valve. Always keep LP cylinders in upright position during use, transit or storage.



OPD Hand Wheel



LP cylinder in upright position for vapor withdrawal

LP (Liquefied Petroleum Gas)

- LP gas is nontoxic, odorless and colorless when produced. **For Your Safety**, LP gas has been given an odor (similar to rotten cabbage) so that it can be smelled.
- LP gas is highly flammable and may ignite unexpectedly when mixed with air.

LP Cylinder Filling

- Use only licensed and experienced dealers.
- LP dealer **must purge new cylinder** before filling.
- Dealer should **NEVER** fill LP cylinder more than 80% of LP cylinder volume. Volume of propane in cylinder will vary by temperature.
- A frosty regulator indicates gas overfill. Immediately close LP cylinder valve and call local LP gas dealer for assistance.
- Do not release liquid propane (LP) gas into the atmosphere. This is a hazardous practice.
- To remove gas from LP cylinder, contact an LP dealer or call a local fire department for assistance. Check the telephone directory under "Gas Companies" for nearest certified LP dealers.

LP Tank Exchange

- Many retailers that sell grills offer you the option of replacing your empty LP tank through an exchange service. Use only those reputable exchange companies that inspect, precision fill, test and certify their cylinders. **Exchange your tank only for an OPD safety feature-equipped tank as described in the "LP Tank" section of this manual.**
- Always keep new and exchanged LP tanks in upright position during use, transit or storage.
- **Leak test new and exchanged LP tanks BEFORE connecting to grill.**

LP Tank Leak Test

For your safety

- Leak test must be repeated each time LP tank is exchanged or refilled.
- Do not smoke during leak test.
- Do not use an open flame to check for gas leaks.
- Grill must be leak tested outdoors in a well-ventilated area, away from ignition sources such as gas fired or electrical appliances. During leak test, keep grill away from open flames or sparks.
- Use a clean paintbrush and a 50/50 mild soap and water solution. Brush soapy solution onto areas indicated by arrows in figure below. Leaks are indicated by growing bubbles.



WARNING



If "growing" bubbles appear do not use or move the LP tank. Contact an LP gas supplier or your fire department!

- ▲ Do not use household cleaning agents. Damage to the gas train components (valve/hose/regulator) can result.

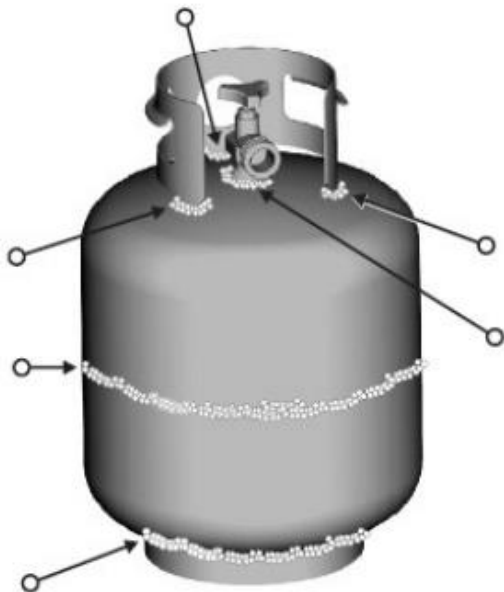

Connecting Regulator To The LP Tank

1. LP tank must be properly secured onto grill. (Refer to assembly section.)
2. Turn all control knobs to the OFF position.
3. Turn LP tank OFF by turning OPD hand wheel clockwise to a full stop.
4. Remove the protective cap from LP tank valve. Always use cap and strap supplied with valve.

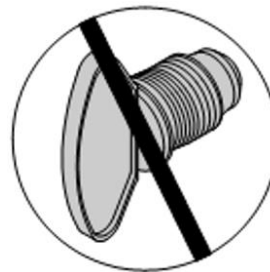
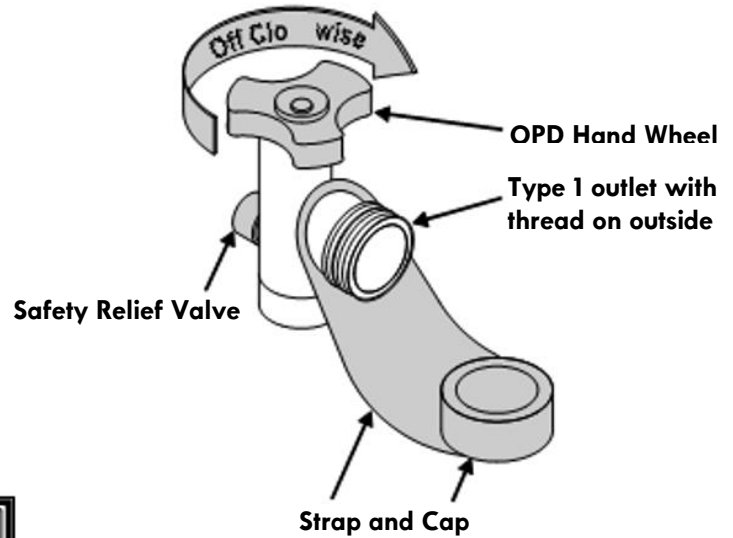

Do not insert a POL transport plug (plastic part with external threads) into the type 1 valve outlet. It will defeat the Safety Relief Valve feature.

5. Hold regulator and insert nipple into LP tank valve. Hand-tighten the coupling nut, holding regulator in a straight line with LP tank valve so as not to cross-thread the connection.

Nipple has to be centered into the LP tank valve.

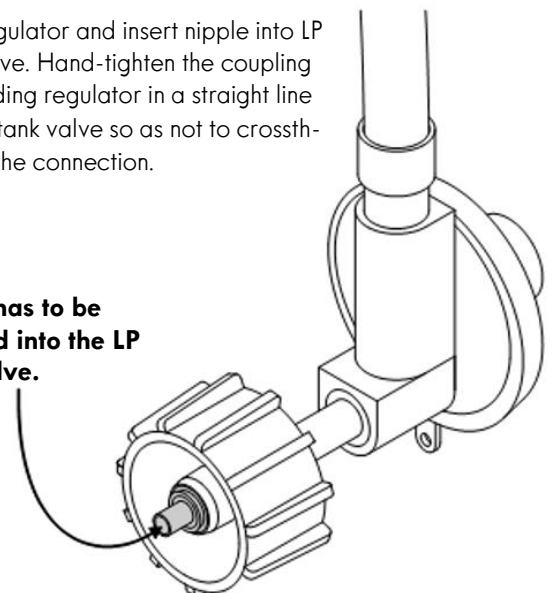

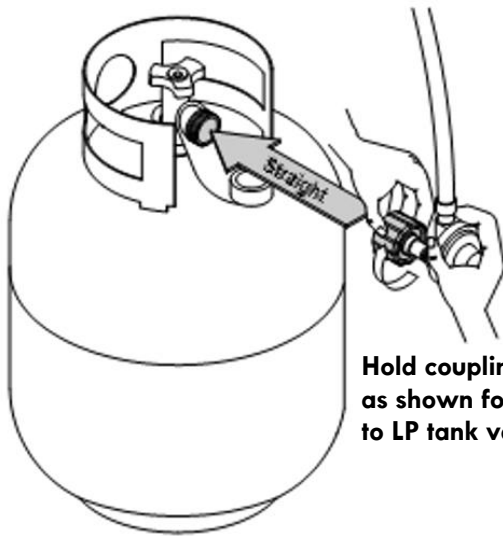

Hold coupling nut and regulator as shown for proper connection to LP tank valve

- Turn the coupling nut clockwise and tighten to a full stop. The regulator will seal on the back-check feature in the LP tank valve, resulting in some resistance. **An additional one-half to three-quarters turn is required to complete the connection. Tighten by hand only - do not use tools.**

NOTE:

If you cannot complete the connection, disconnect regulator and repeat steps 5 and 6. If you are still unable to complete the connection, do not use this regulator!
Call **1-844-553-6667** for an identical replacement part.

Leak Testing Valves, Hose and Regulator

- Turn all grill control knobs to OFF.
- Be sure regulator is tightly connected to LP tank.
- Completely open LP tank valve by turning OPD hand wheel counterclockwise. If you hear a rushing sound, turn gas off immediately. There is a major leak at the connection. **Correct before proceeding** by calling Sears for replacement parts at **1-844-553-6667**.
- Brush soapy solution onto areas where bubbles are shown in picture below:

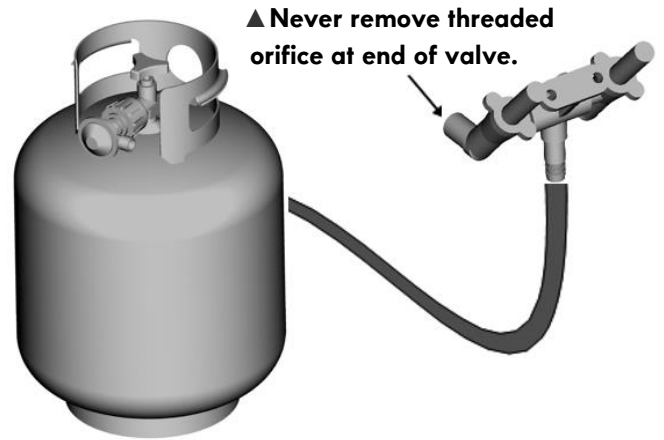

- If "growing" bubbles appear, there is a leak. Close LP tank valve immediately and retighten connections. If leaks cannot be stopped do not try to repair. Call for replacement parts at **1-844-553-6667**.
- Always close LP tank valve after performing leak test by turning hand wheel clockwise.

	DANGER	
<ul style="list-style-type: none"> Do not insert any tool or foreign object into the valve outlet or safety relief valve. You may damage the valve and cause a leak. Leaking propane may result in explosion, fire, severe personal injury, or death. 		

	WARNING	
<ul style="list-style-type: none"> Outdoor gas appliance is not intended to be installed in or on a boat. Outdoor gas appliance is not intended to be installed in or on an RV. Never attempt to attach this grill to the self-contained LP gas system of a camper trailer or motor home. Do not use grill until leak-tested. If a leak is detected at any time, STOP and call the fire department. If you cannot stop a gas leak, immediately close LP cylinder valve and call LP gas supplier or your fire department! 		

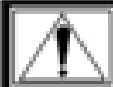

WARNING

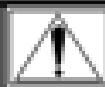

For Safe Use of Your Grill and to Avoid Serious Injury:

- Do not let children operate or play near grill.
- Keep grill area clear and free from materials that burn.
- Do not block holes in sides or back of grill.
- Use grill only in well-ventilated space. NEVER use in enclosed space such as carport, garage, porch, covered patio, or under an overhead structure of any kind.
- Do not use charcoal or ceramic briquets in a gas grill.
- Use grill at least 3 ft. from any wall or surface. Maintain 10 ft. clearance to objects that can catch fire, or to sources of ignition etc.



• Apartment Dwellers:

- Check with management to learn the requirements and fire codes for using an LP gas grill in your apartment complex. If allowed, use outside on the ground floor with a three (3) foot clearance from walls or rails. Do not use on or under balconies.
- NEVER attempt to light burner with lid closed. A buildup of non-ignited gas inside a closed grill is hazardous.
 - Never operate grill with LP cylinder out of correct position specified in assembly instructions.
 - Always close LP cylinder valve and remove coupling nut before moving LP cylinder from specified operation position.

Safety Tips

- ▲ Before opening LP cylinder valve, check the coupling nut for tightness.
- ▲ When grill is not in use, turn off all control knobs and LP cylinder valve.
- ▲ Never move grill while in operation or still hot.
- ▲ Use long-handled barbecue utensils and oven mitts to avoid burns and splatters.
- ▲ Maximum load for side burner and side shelf is 10 lbs.
- ▲ The drip tray must be inserted into grill and emptied after each use. Do not remove drip tray until grill has completely cooled.
- ▲ Clean grill often, preferably after each cookout. If a bristle brush is used to clean any of the grill cooking surfaces, ensure no loose bristles remain on cooking surfaces prior to grilling. It is not recommended to clean cooking surfaces while grill is hot.
- ▲ If you notice drip or other hot material dripping from grill, determine the cause, correct it, then clean and inspect valve. Keep ventilation openings in cylinder enclosure (grill cart) free and clear of debris.
- ▲ Do not store objects or materials inside the grill cart enclosure that would block the flow of combustion air to the underside of either the control panel or the firebox bowl.
- ▲ The regulator may make a humming or whistling noise during operation. This will not affect safety or use of grill.
- ▲ If you have a grill problem see the "Troubleshooting Section".
- ▲ If the regulator frosts, turn off grill and LP cylinder valve immediately. This indicates a problem with the cylinder and it should not be used on any product. Return to supplier!



CAUTION



- Putting out drip fires by closing the lid is not possible. Grills are well ventilated for safety reasons.
- Do not use water on a drip fire. Personal injury may result. If a drip fire develops, turn knobs and LP cylinder off.
- Do not leave grill unattended while preheating or burning off food residue on HI. If grill has not been regularly cleaned, a drip fire can occur that may damage the product.

Main Burner Igniter Lighting

- ▲ Do not lean over grill while lighting.
 1. Open lid during lighting.
 2. Turn on valve from source or tank.
 3. To ignite, turn Ignition Burner knob to HI.
 4. Push and hold electronic ignition button.
 5. If ignition does not occur in 5 seconds, turn the burner controls OFF, wait 5 minutes, and repeat the lighting procedure.
 6. To ignite other main burners after Ignition Burner is lit, turn a control knob that is adjacent to a lit burner to HI. Ignite far left burner last.
 7. Once burners are lit, adjust knobs to desired flame setting. To extinguish an individual burner, turn its knob to OFF.
 8. To ignite the Side Burner, follow steps 3-5 using the Side Burner knob.
- If igniter does not work, follow Match Lighting instructions



WARNING



Turn controls and gas source or tank OFF when not in use.



CAUTION



If ignition does NOT occur in 5 seconds, turn the burner controls OFF, wait 5 minutes and repeat the lighting procedure. If the burner does not ignite with the valve open, gas will continue to flow out of the burner and could accidentally ignite with risk of injury.

Match Lighting Instructions

▲ Do not lean over grill while lighting.

1. Open lid during lighting.
2. Place match into match holder (hanging on the left front leg inside cabinet).
3. Light match and insert match holder through lighting hole in left side of firebox. Align lit match with first burner on left.
4. Turn knob of first left burner to HI position. Be sure burner lights and stays lit. Withdraw match holder from firebox and extinguish match.
5. To light other burners, turn each knob in succession to HI.
6. Once burners are lit, adjust knobs to desired flame setting. To extinguish an individual burner, turn its knob to OFF.

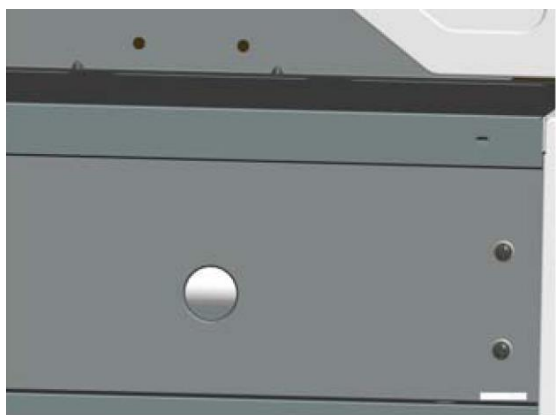

Sideburner Match Lighting

1. Open sideburner lid. Turn on gas at LP cylinder.
2. Place lit match near burner.
3. Turn sideburner knob to HI. Be sure burner lights and stays lit.



Burner Flame Check

- Remove cooking grates and heat diffusers. Light burners, turn knobs from HI to LO. You should see a smaller flame in LO position than seen on HI. Perform burner flame check on searing burner, also. Always check flame prior to each use. If only low flame is seen refer to "Sudden flame drop or low flame" in the Troubleshooting Section.

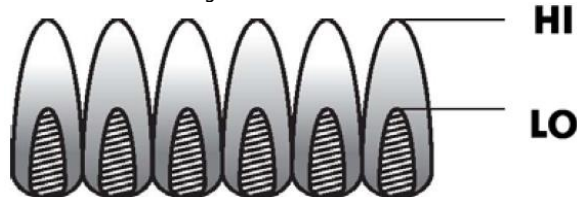

Turning Grill Off

- Turn all knobs to OFF position. Turn LP cylinder off.
- When you are finished grilling, raise the grill lid while allowing the grill to fully cool. If the grill lid is closed during grill cooling, condensation may occur on interior grill surfaces and possibly cause them to rust.

Igniter Check

- Turn gas off at LP cylinder. Press and hold electronic igniter button. "Click" should be heard and spark seen each time between collector box or burner and electrode. See "Troubleshooting" if no click or spark.

Valve Check

- Important: Make sure gas is off at LP cylinder before checking valves. Knobs lock in OFF position. To check valves, first push in knobs and release, knobs should spring back. If knobs do not spring back, replace valve assembly before using grill. Turn knobs to LOW position then turn back to OFF position. Valves should turn smoothly.

Hose Check

- Before each use, check to see if hoses are cut or worn. Replace damaged hoses before using grill. Use only valve/hose/regulator as specified in the parts list of this Use & Care Guide.

Cast Iron Grate Seasoning (if applicable)

First Use—Before first use, season cast iron grates as follows: Rinse cast iron grates with hot water. Do not use soap. Dry grates thoroughly with a cloth towel. Coat grates with vegetable oil or non-stick cooking spray. Place grates in grill. Start grill and slowly raise temperature to 350° - 400° F. Heat grates for one hour. Turn off grill and allow grates to cool completely before using to cook.

Cleaning—Do not use soap when cleaning grates. Clean grates with a stiff brush and hot water. Dry grates thoroughly with a cloth towel.

Re-seasoning—Re-season grates when rust spots appear on grate surface. When re-seasoning grates, soap may be used with hot water to clean grates. After cleaning, dry grates thoroughly with a cloth towel. Coat grates with vegetable oil or non-stick cooking spray. Place grates in grill. Start grill and slowly raise temperature to 350° - 400° F. Heat grates for one hour. Turn off grill and allow grates to cool completely before using again.

General Grill Cleaning

- Do not mistake brown or black accumulation of grease and smoke for paint. Interiors of gas grills are not painted at the factory (**and should never be painted**). Apply a strong solution of detergent and water or use a grill cleaner with scrub brush on insides of grill lid and bottom. Rinse and allow to completely air dry. **Do not apply a caustic grill/oven cleaner to painted surfaces.**
- **Porcelain surfaces:** Because of glass-like composition, most residue can be wiped away with baking soda/water solution or specially formulated cleaner. Use nonabrasive scouring powder for stubborn stains.
- **Painted surfaces:** Wash with mild detergent or nonabrasive cleaner and warm soapy water. Wipe dry with a soft nonabrasive cloth.

- **Painted surfaces:** Wash with mild detergent or nonabrasive cleaner and warm soapy water. Wipe dry with a soft nonabrasive cloth.
- **Stainless steel surfaces:** To maintain your grill's high quality appearance, wash with mild detergent and warm soapy water and wipe dry with a soft cloth after each use. Baked-on drip deposits may require the use of an abrasive plastic cleaning pad. Use only in direction of brushed finish to avoid damage. Do not use abrasive pad on areas with graphics.
- **Cooking surfaces:** If a bristle brush is used to clean any of the grill cooking surfaces, ensure no loose bristles remain on cooking surfaces prior to grilling. It is not recommended to clean cooking surfaces while grill is hot.
- **Drip Tray and Cup:** Regularly clean the drip drippings from the Drip Tray and Drip Cup. When the grill has completely cooled down after use, remove the cup from the tray and slide the tray out of the grill. Clean the drip drippings from the cup and tray surfaces by washing with mild detergent or nonabrasive cleaner and warm soapy water. Wipe dry with a soft nonabrasive cloth. Slide the tray back into the grill and replace the cup back into the tray before using the grill again.



SPIDER ALERT!

IMPORTANT: Always ensure that the venturi burner tubes are clean. A venturi burner tube has a narrow area in which spiders tend to build nests.

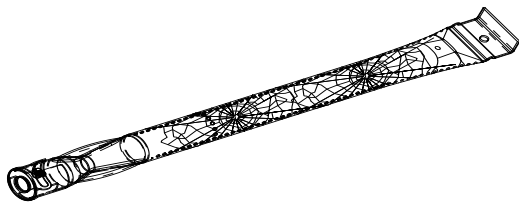

If you notice that your grill is getting hard to light or that the flame isn't as strong as it should be, take the time to check and clean the venturi's.

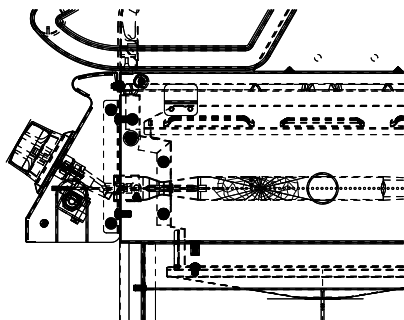

Spiders or small insects have been known to create "flashback" problems. The spiders spin webs, build nests and lay eggs in the grill's venturi tube(s) obstructing the flow of gas to the burner. The backed-up gas can ignite in the venturi behind the control panel. This is known as a flashback and it can damage your grill and even cause injury.

To prevent flashbacks and ensure good performance the burner and venturi assembly should be removed from the grill and cleaned before use whenever the grill has been idle for an extended period.

Storing Your Grill

- Clean cooking grates.
- Store in dry location.
- When LP cylinder is connected to grill, store outdoors in a well-ventilated space and out of reach of children.
- Cover grill if stored outdoors. Choose from a variety of grill covers offered by manufacturer once available.
- Store grill indoors **ONLY** if LP cylinder is turned off and Disconnected, remove from grill and stored outdoors.
- When removing grill from storage, follow "Cleaning the Burner Assembly" instructions before starting grill.

Cleaning the Burner Assembly

Follow these instructions to clean and/or replace parts of burner assembly or if you have trouble igniting grill.

1. Turn gas off at control knobs and LP cylinder.
2. Remove cooking grates and heat diffusers.
3. Remove cotter pin from rear of burners. See Fig. A next page.
4. Carefully lift each burner up and away from valve openings. We suggest three ways to clean the burner tubes. Use the one easiest for you.

- (A) Bend a stiff wire (a light weight coat hanger works well) into a small hook. Run the hook through each burner tube several times.



- (B) Use a narrow bottle brush with a flexible handle (do not use a brass wire brush), run the brush through each burner tube several times.

- (C) Wear eye protection: Use an air hose to force air into the burner tube and out the burner ports. Check each port to make sure air comes out each hole.

5. Wire brush entire outer surface of burner to remove food residue and dirt.
6. Clean any blocked ports with a stiff wire such as an open paper clip.
7. Check burner for damage, due to normal wear and corrosion some holes may become enlarged. If any large cracks or holes are found replace burner.

VERY IMPORTANT: Burner tubes must reengage valve openings. See illustrations below.

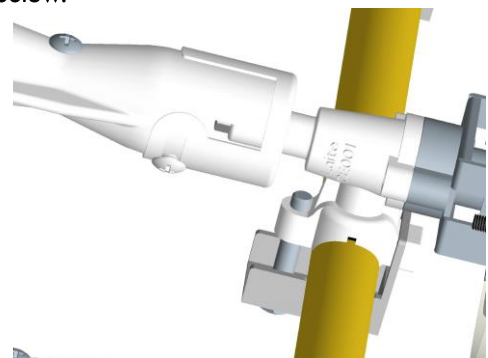

8. Carefully replace burners.
9. Attach burners to brackets with cotter pin. See Fig. B next page.
10. Replace heat diffusers and cooking grates

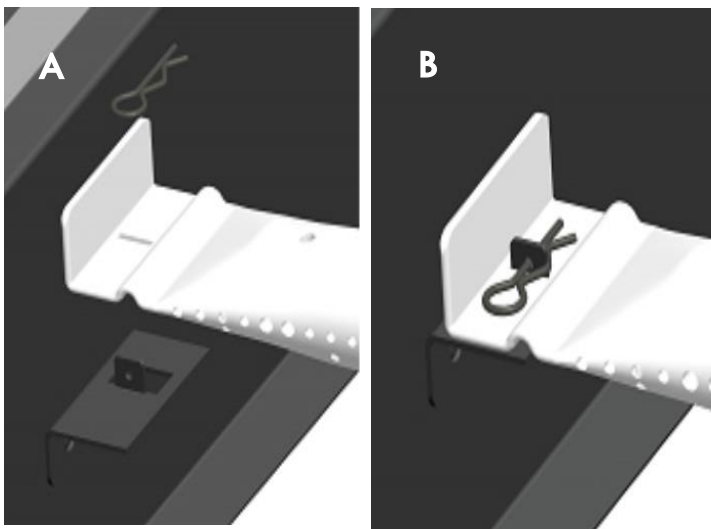

Indirect Cooking

Poultry and large cuts of meat cook slowly to perfection on the grill by indirect heat. Place food over unlit burner(s); the heat from lit burners circulates gently throughout the grill, cooking meat or poultry without the touch of a direct flame. This method greatly reduces flare-ups when cooking extra fatty cuts because there is no direct flame to ignite the fats and juices that drip during cooking.

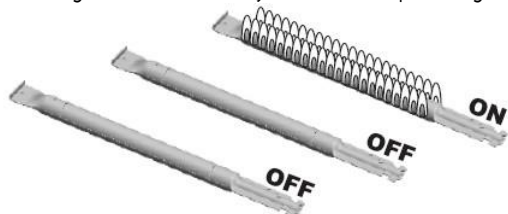

1 Burner Cooking

Cook with direct or indirect heat.
Best for smaller meals or foods.
Consumes less fuel.

Indirect Cooking Instructions

- Always cook with the lid closed.
- Once burners are lit, extinguish an individual burner by turning its knob to OFF.
- Due to weather conditions, cooking times may vary. During cold and windy conditions the temperature setting may need to be increased to insure sufficient cooking heat.
- Place food over unlit burner(s).

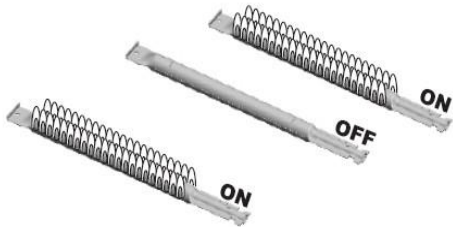

2 Burner Cooking

Great indirect cooking on low.
Produces slow, even heating.
Ideal for slow roasting and baking.

Food Safety

Food safety is a very important part of enjoying the outdoor cooking experience. To keep food safe from harmful bacteria, follow these four basic steps:

Clean: Wash hands, utensils, and surfaces with hot soapy water before and after handling raw meat and poultry.

Separate: Separate raw meats and poultry from ready-to-eat foods to avoid cross contamination. Use a clean platter and utensils when removing cooked foods.

Cook: Cook meat and poultry thoroughly to kill bacteria. Use a thermometer to ensure proper internal food temperatures.

Chill: Refrigerate prepared foods and leftovers promptly. **For more information call: USDA Meat and Poultry Hotline at 1-800-535-4555 (In Washington, DC (202) 720-3333, 10:00 am 4:00 pm EST).**

How To Tell If Meat Is Grilled Thoroughly

- Meat and poultry cooked on a grill often browns very fast on the outside. Use a meat thermometer to be sure food has reached a safe internal temperature, and cut into food to check for visual signs of doneness.
- Whole poultry should reach 180° F; breasts, 170° F. Juices should run clear and flesh should not be pink.
- Hamburgers made of any ground meat or poultry should reach 160° F, and be brown in the middle with no pink juices. Beef, veal and lamb steaks, roasts and chops can be cooked to 145° F. All cuts of pork should reach 160° F.
- NEVER partially grill meat or poultry and finish cooking later. Cook food completely to destroy harmful bacteria.
- When reheating takeout foods or fully cooked meats like hot dogs, grill to 165° F, or until steaming hot.

WARNING: To ensure that it is safe to eat, food must be cooked to the minimum internal temperatures listed in the table below.

USDA* Recommended Safe Minimum Internal Temperatures	
Beef, Veal, Lamb and Pork – Whole Cuts**	145° F
Fish	145° F
Beef, Veal, Lamb and Pork – Ground	160° F
Egg Dishes	160° F
Turkey, Chicken & Duck – Whole, Pieces & Ground	165° F

* United States Department of Agriculture

**Allow meat to rest three minutes before carving or consuming.

PARTS LIST

Key	Description	Qty	Part Number	Key	Description	Qty	Part Number
1	Side Burner Lid	1	40800065	31	Bottom Shelf	1	52200073
2	Side Burner Grid	1	40800119	32	Front Panel	2	40600028Z
3	Rotate Rod, Side Burner Lid	2	40800118	33	Side Lower Rail	2	52200064
4	Side Burner Base	1	52200052	34	Side Upper Rail	2	52200061
5	Side Burner	1	40600031	35	Tank Baffle	1	40800090
6	Igniter Wire, Side Burner	1	52200054	36	Drip Cup	1	40800026
7	Igniter Wire, Main Burner	1	52200035	37	Drip Cup Clip	1	40800131
8	Right Side Shelf	1	40900145	38	Drip Tray	1	40600014
9	Fire Box	1	40600004	39	Right Drip Tray Support	1	40600027
10	Electronic Ignition Module	1	40600030Z	40	Left Drip Tray Support	1	40600026
11	Fascia, Right Shelf	1	41100023Z	41	Back Rail	1	52200074
12	Control Panel	1	40100022Z	42	Fascia, Left Side Shelf	1	40900040Z
13	Gas Valve, Main Burner	4	40900205	43	Left Side Shelf	1	40900143
14	Manifold, Main Burner	1	40300037	44	Side Shelf Support Angle Bar	2	40900109
15	Side Burner Hose	1	40900210	45	Flame Carry Over Tube	3	40300019
16	Gas Valve, Side Burner	1	40900209	46	Cooking Grate	2	40100101
17	Bezel, Control Knob	5	40900036Z	47	Silicone Rubber Bumper, Firebox	2	50300205
18	Control Knob	5	40900206Z	48	Silicone Rubber Bumper, Lid	2	40700103
19	Regulator	1	408D00115	49	Warming Rack	1	40300104
20	Alex Rod	1	408D00125	50	Lid Handle	1	40900012Z
21	Match Holder Chain	1	120006	51	Bezel, Lid Handle	2	40900013Z
22	Cotter Pin	10	110050	52	Lid Handle Spacers	2	40700022
23	Hose Fixed Pin	1	40800134	53	Temperature Gauge	1	41100101Z
24	Leg Extender	2	40800127	54	Logo	1	40800106Z
25	Caster	2	40800124	55	Lid	1	50500004Z
26	Right Back Leg	1	40600025	56	Heat Diffuser	4	40800023
27	Right Front Leg	1	40600024	57	Rotated Rod, Lid	2	50300207
28	Left Front Leg	1	40600021	58	Flat Washer	3	110018
29	Left Back Leg	1	40600022	59	Hex Nut	3	110011
30	Tank Holder	1	40800130	60	Burner	1	40600013
				61	Main Burner	3	40600012

Not Pictured

Hardware Pack	1	40600049
Manual	1	40600050Z

If you are missing hardware or have damaged parts after unpacking grill, call 1-888-287-0735 for replacement.

To order replacement parts after using grill, call 1-844-553-6667.

NOTES: Some grill parts shown in the assembly steps may differ slightly in appearance from those on your particular grill. However, the method of assembly remains the same.

PARTS DIAGRAM

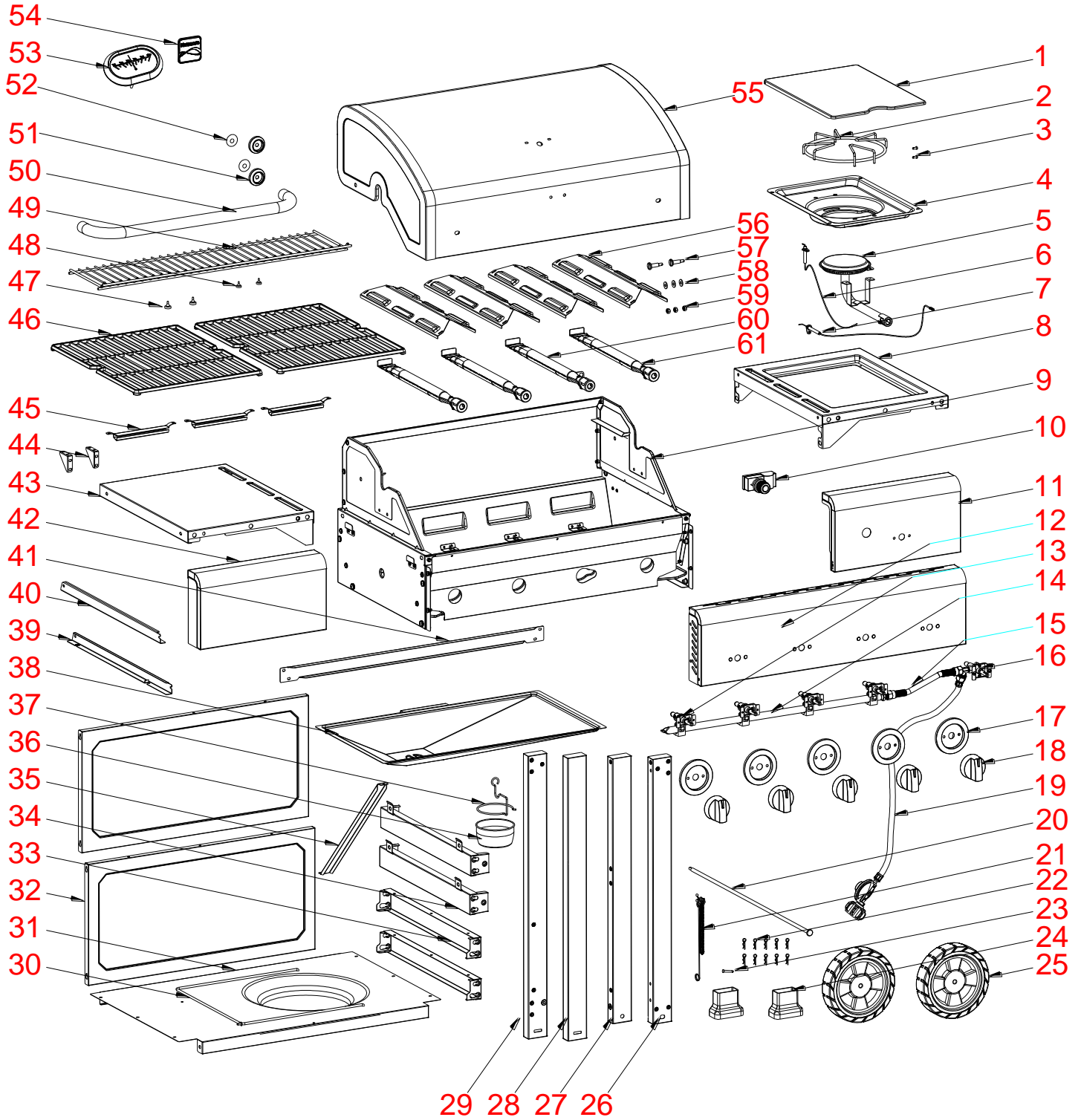

BEFORE ASSEMBLY

NOTICE: Once you have unpacked the grill according to the **STOP SHEET** instructions, check all grill parts against the pictures on this and the following two pages. If any parts are missing or damaged, call 1-888-287-0735.

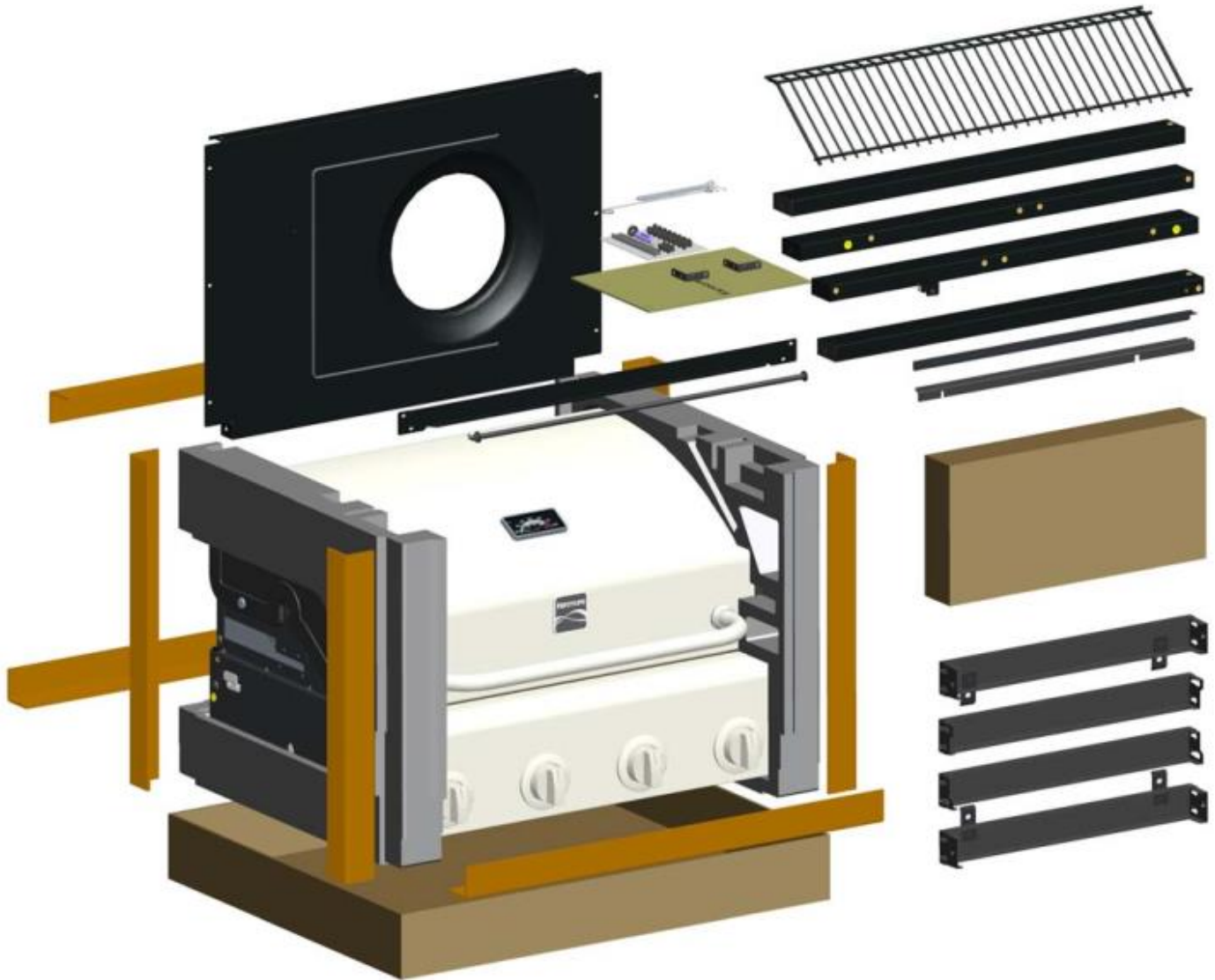

BEFORE ASSEMBLY

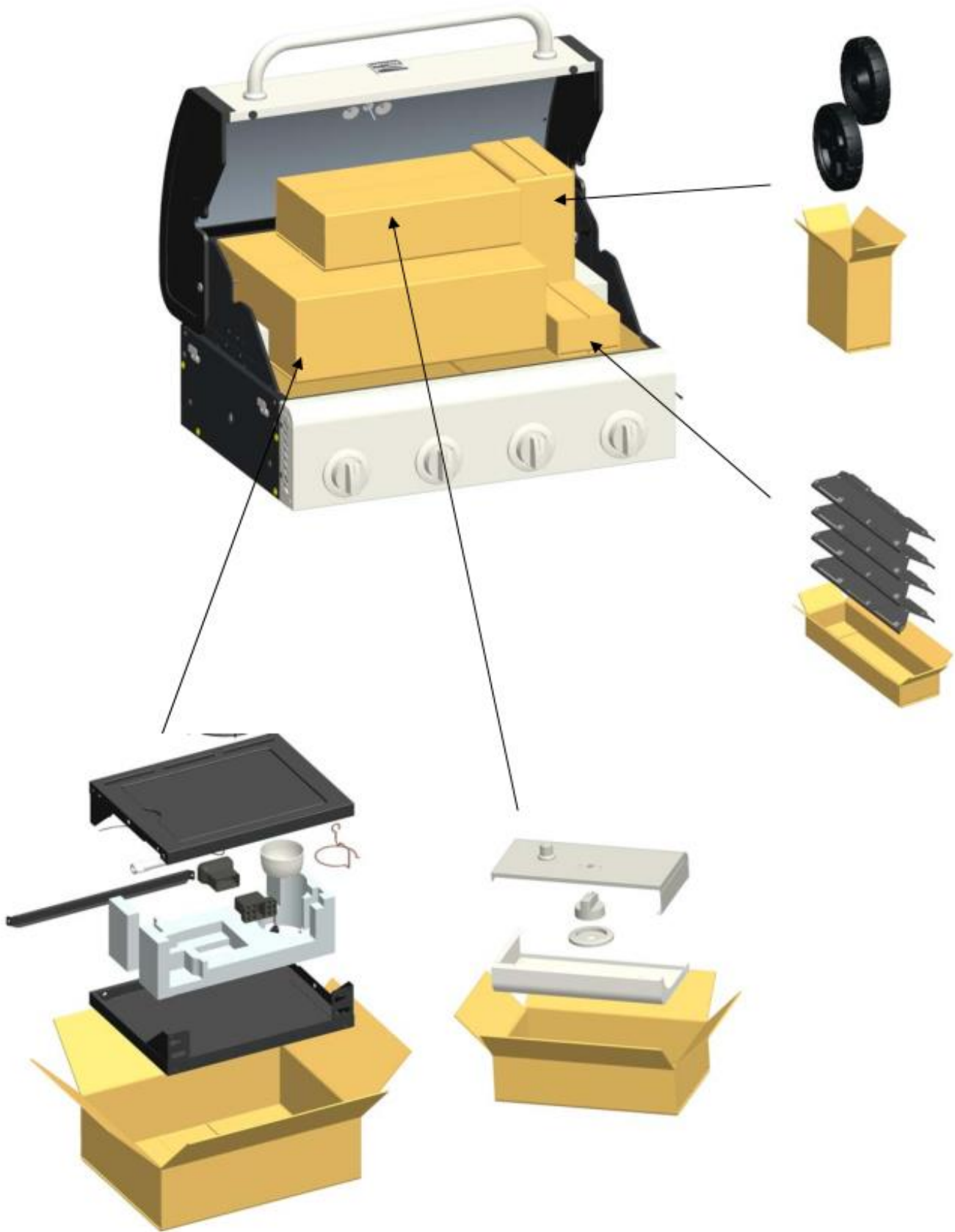

BEFORE ASSEMBLY







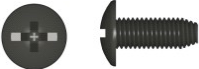

ASSEMBLY

CAREFULLY READ AND PERFORM ALL ASSEMBLY INSTRUCTIONS ON THE FOLLOWING PAGES.

Tools Required:

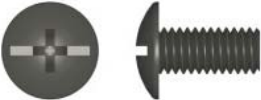
- Adjustable wrench (not provided)
- Screwdriver (not provided)
- 7/16" Combination wrench (not provided)
- The following hardware is provided in blister pack for convenient use.

M4X10 screw Qty: 54 pcs 	AA Battery Qty: 1 pc 
M5X10 screw Qty: 4 pcs 	M5 flat washer Qty: 4 pcs 
M6X13 screw Qty: 16 pcs 	M6 compression washer Qty: 4 pcs 

1

Left Frame

- Install (4)M4 × 10 Screws as shown to the leg marked “5A”. Do not fully tighten the screws at this time. Leave 1/8-inch gap below screw head for rail attachment. (A)
- Attach one end of a Side Upper Rail “6A” to the leg, tighten the screws and install and tighten another (1)M4 × 10 Screw.(C)
- Attach one end of a Side Lower Rail “6B” to the leg and tighten the screws. (C)
- Install (4)M4 × 10 Screws as shown to the leg marked “5B”. Do not fully tighten the screws at this time. Leave 1/8-inch gap below screw head for rail attachment. (B)
- Attach the other end of Side Upper Rail and Side Lower Rail to the “5B” Leg and tighten the screws. Install and tighten another (1)M4X10 Screw to the Side Upper Rail. (D)

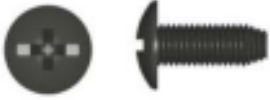

M4x10 screws Qty: 10 pcs

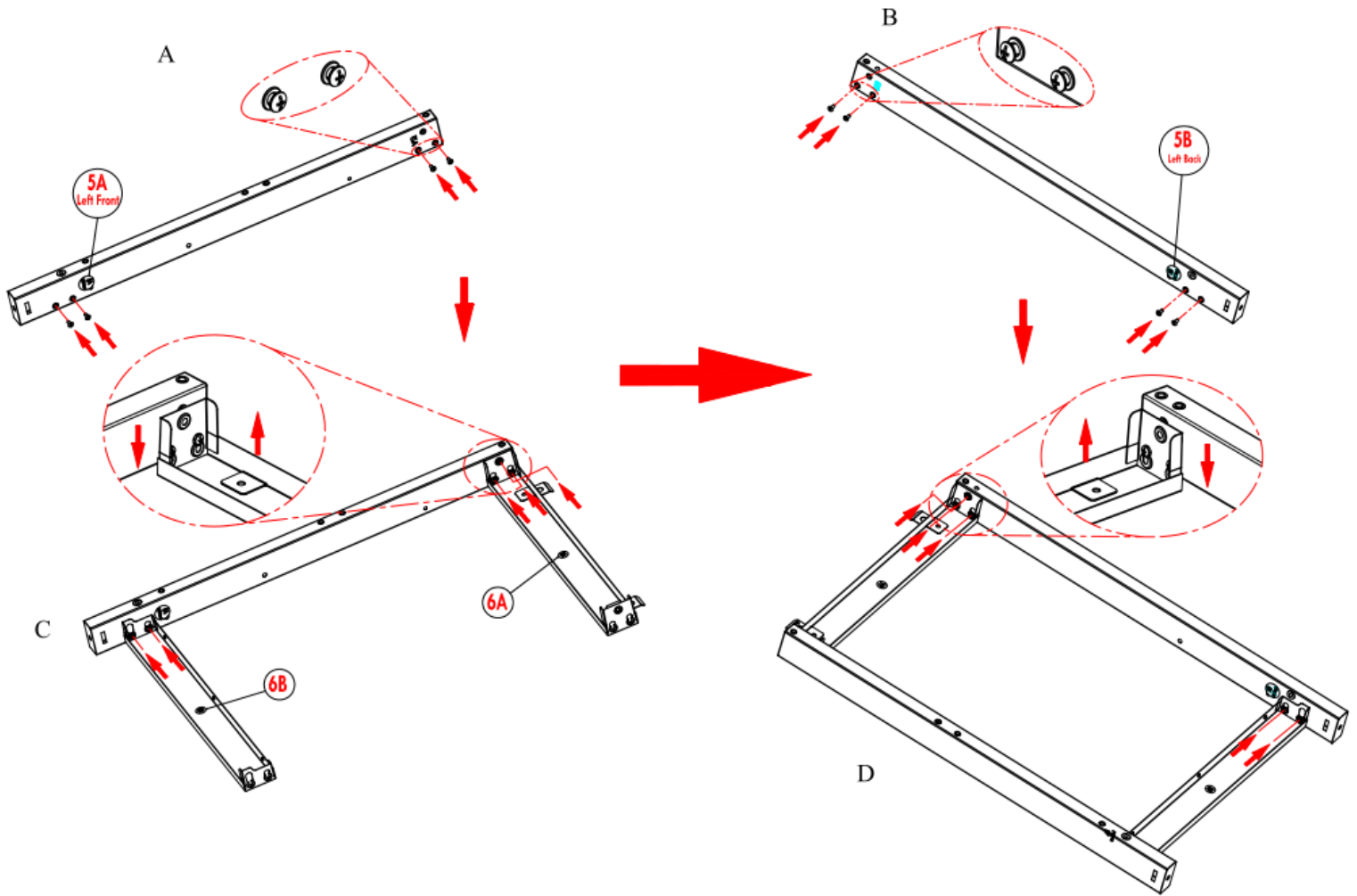

2

Right Frame

- Install (4)M4 × 10 Screws as shown to the leg marked “5C” . Do not fully tighten the screws at this time. Leave 1/8-inch gap below screw head for rail attachment. (A)
- Attach one end of a Side Upper Rail “6A” to the leg, tighten the screws and install and tighten another (1)M4 × 10 Screw.(C)
- Attach one end of a Side Lower Rail “6B” to the leg and tighten the screws. (C)
- Install (4)M4 × 10 Screws as shown to the leg marked “5D” . Do not fully tighten the screws at this time. Leave 1/8-inch gap below screw head for rail attachment. (B)
- Attach the other end of Side Upper Rail and Side Lower Rail to the “5D” Leg and tighten the screws. Install and tighten another (1)M4X10 Screw to the Side Upper Rail. (D)



M4x10 screws Qty: 10 pcs

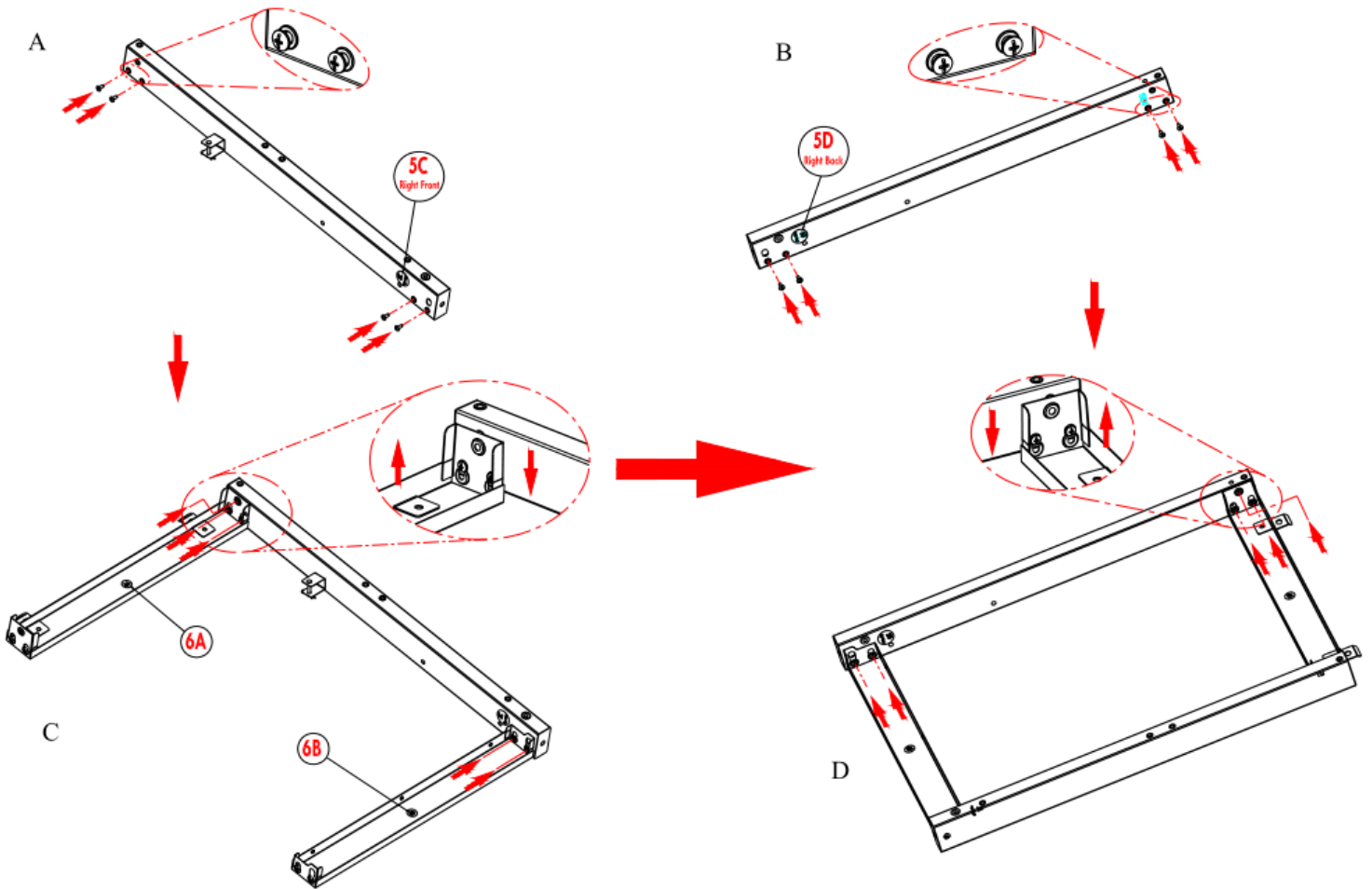

3

Bottom Shelf

- Install (4) M4 × 10 Screws as shown to Right Frame. Do not fully tighten the screws at this time. Leave 1/8-inch gap below screw head for panel attachment. (A)
- Install (4) M4X10 screws as shown to Left Frame. Do not fully tighten screws at this time. Leave 1/8-inch gap below screw head for panel attachment. (B)
- Attach Bottom Shelf to Right Frame with (3) M4X10 screws. Do not yet fully tighten these screws. (A)
- Attach Bottom Shelf to Left Frame with (3) M4X10 screws. Do not yet fully tighten these screws. (B)



M4x10 screws Qty: 14 pcs

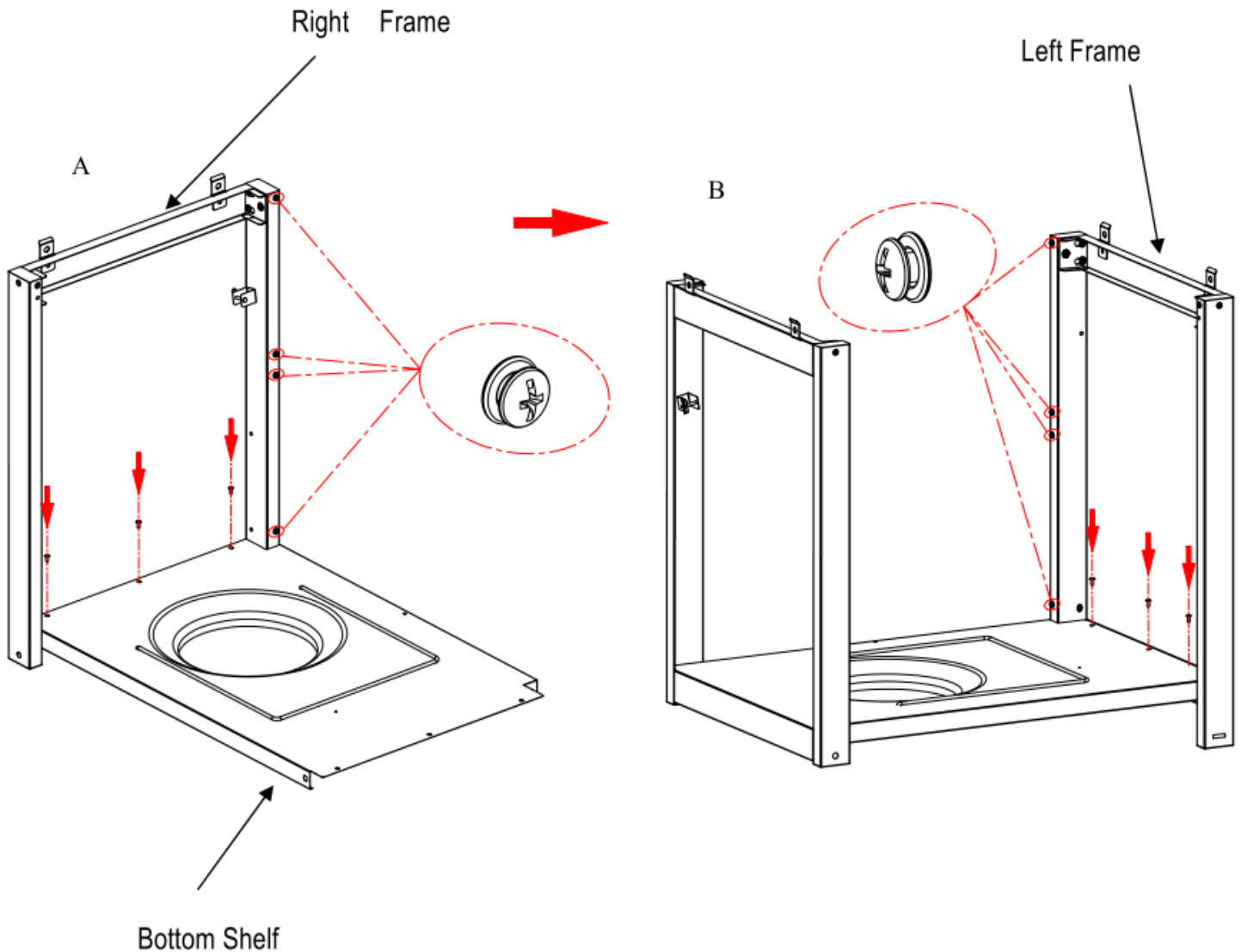

4

Front Panel

- Attach the two front panel sections together into a single front panel with (1) M4X10 screw as shown.
- Attach the front panel to the cart by slipping the four panel holes on each side over and down onto the four protruding screw heads on the left and right frames. Leave the top screw loose on each side, and fully tighten the other three screws on each side.
- Slide one end of the Right Drip Tray Support Bar “7A” under the front Right Frame top screw. Fully tighten the screw. Fully tighten other end of bar to the rear Right Frame with (1)M4 × 0 10 Screw. (C)
- Slide one end of the Left Drip Tray Support Bar “7B” under the front Left Frame top screw. Fully tighten the screw. Fully tighten other end of bar to the rear Left Frame with (1)M4 × 10 Screws as shown. Install and fully tighten (1) M4X10 screw through the middle screw hole on the bottom of the front panel into the bottom shelf. (D)

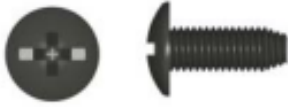

M4x10 screws Qty: 4 pcs

A

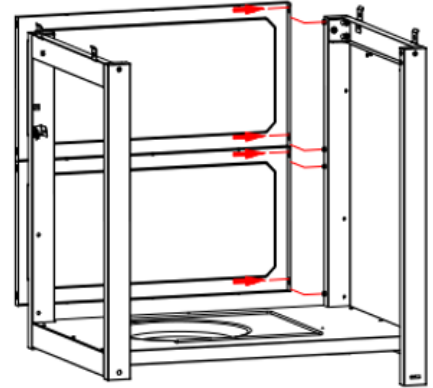
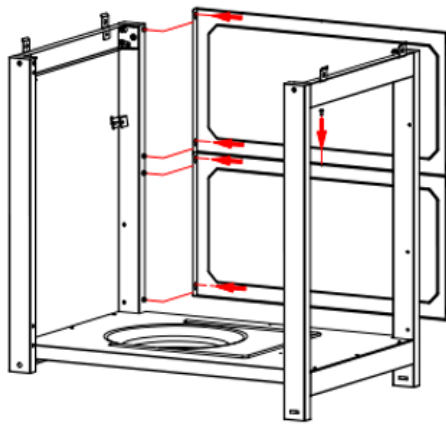

B

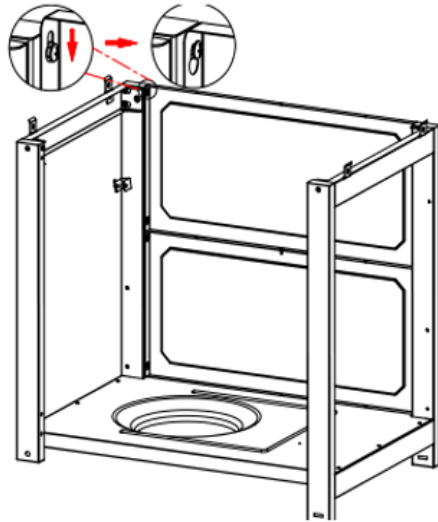

C

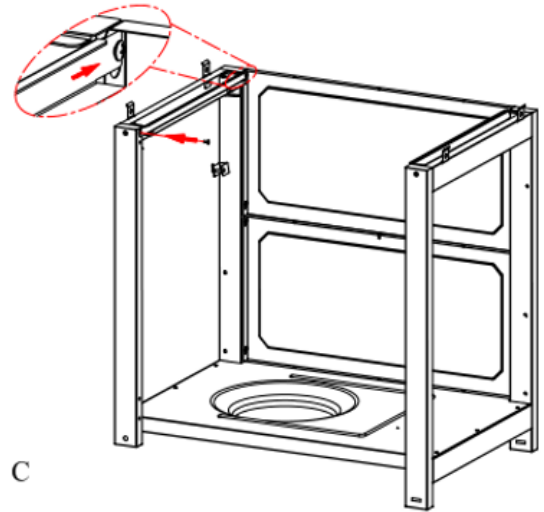

D

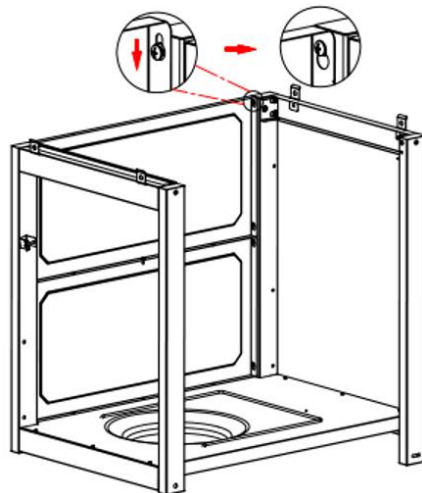

D

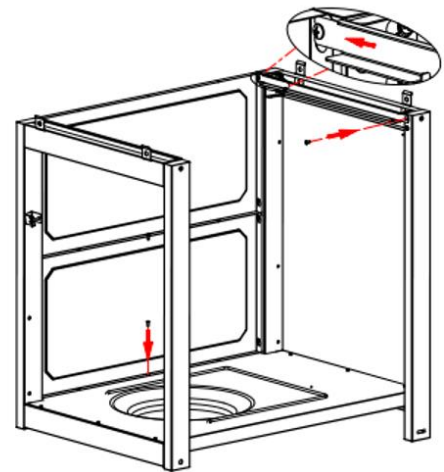

5

Wheels to Cart

- Turn cart upside down and attach Legs to Bottom Shelf with (4) M6X13 screws as shown. (A)
- Tap both Leg Extenders onto Left Legs. (B)
- Remove hitch pin, nut and washer from axle rod. Insert axle rod through Wheels and Right Leg Frame. Reattach washer, nut and hitch pin. (C)
- Note: The convex side of the wheel must face to the cart, and the concave side must face outward.**
- Stand cart right side up and fully tighten the (6) M4X10 bottom shelf screws. (D) Attach Tank Baffle as shown with (2) M4X10 screws. (D)

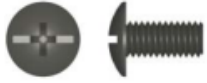

M6X13 screw Qty: 4 pcs



M4X10 screw Qty: 2 pcs

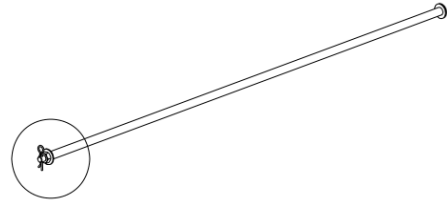

A

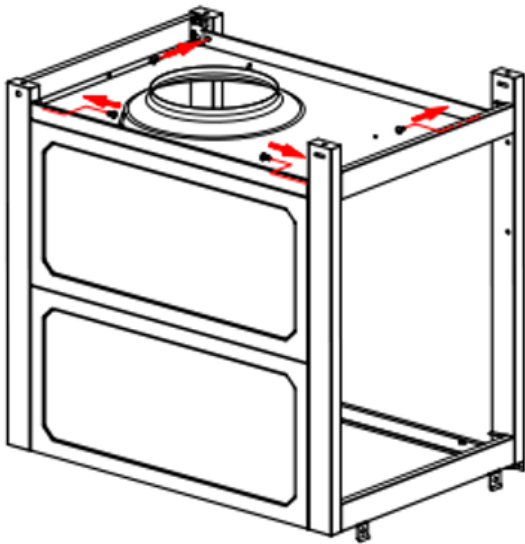

B

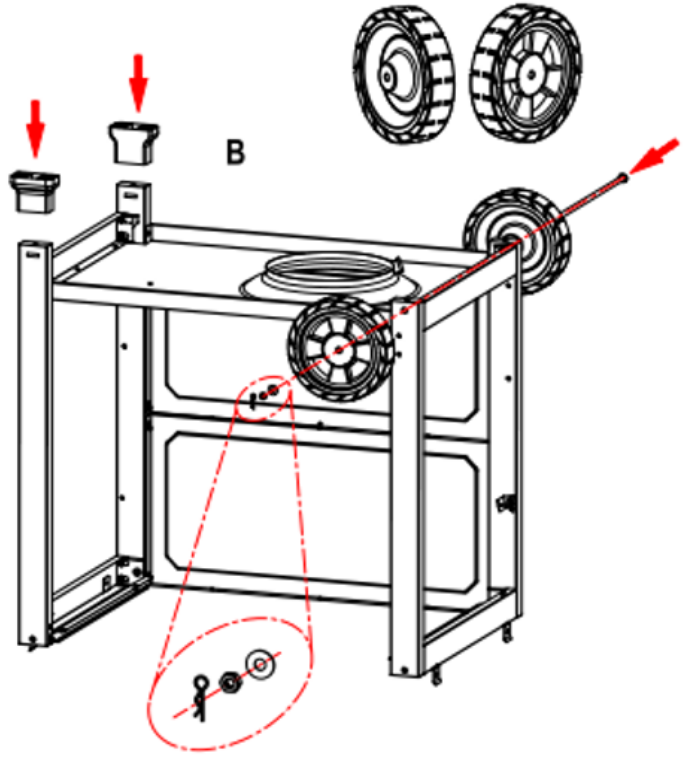

C

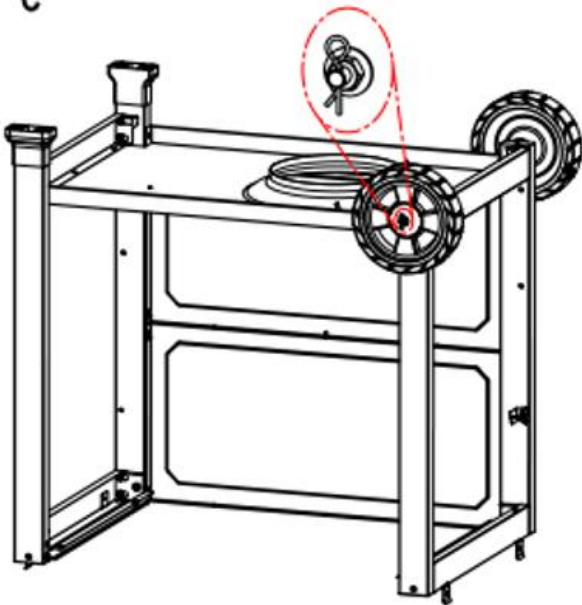

D

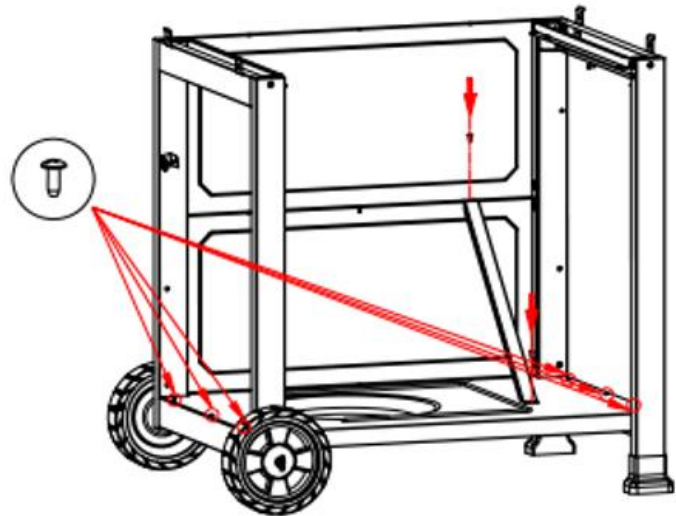

6

Grill Head to Cart

- This step requires two people to lift and position grill head onto cart.
- Remove the tie wraps and packaging material from regulator hose, side burner valve and igniter wire. Pull hose and igniter wire out to side of grill head.
- Carefully lower the grill head onto the cart. Make sure the regulator hose and igniter wire are hanging outside the cart.
- Line up control panel so that it is flush with front panels. Attach head to cart with (4) M6X13 screws.



M6X13 screw Qty: 4 pcs

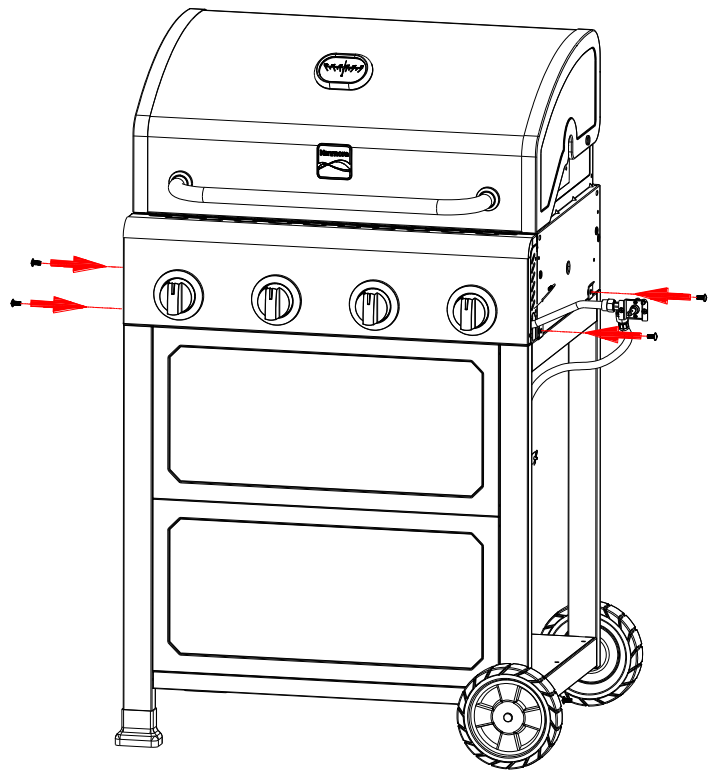
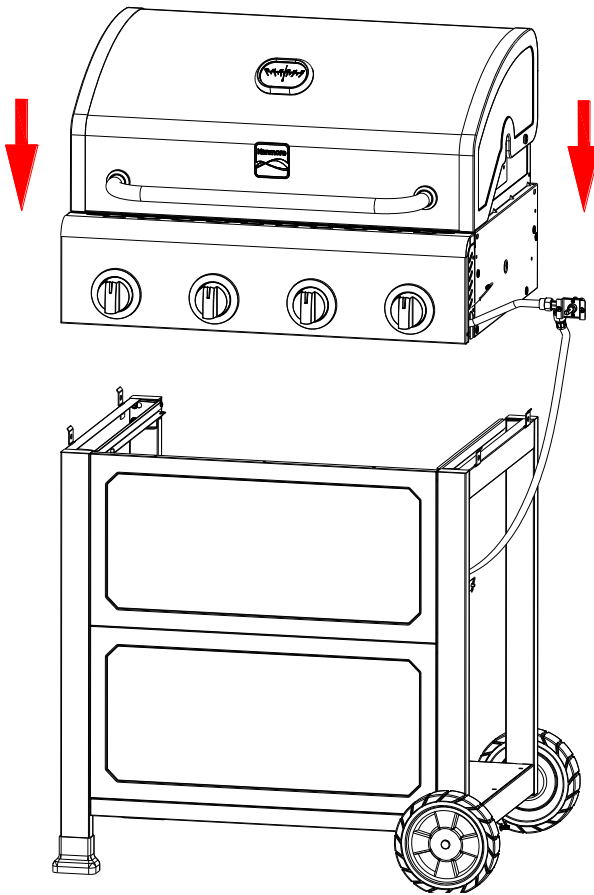

7

Left Side Shelf

- Attach fascia to left side shelf with (2) M5x10 screws and M5 flat washers. (A)
- Attach Side Shelf Support Angle Bar with (4) M4x10 screws.(B)
- Hang shelf onto brackets on left side of firebox.
- Attach shelf to firebox as follows:
 - From inside to outside of firebox with (2) M6x13 screws and M6 compression washers. (C)
 - From outside to inside of firebox with (2) M6x13 screws. (D)
- Attach fascia to control panel with (1) M4x10 screw. (D)



M5X10 screw Qty: 2 pcs



M5 flat washer Qty: 2 pcs

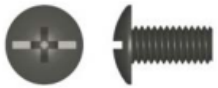

M6X13 screws Qty: 4 pcs



M6 compression washer Qty: 2 pcs



M4X10 screw Qty: 5 pcs

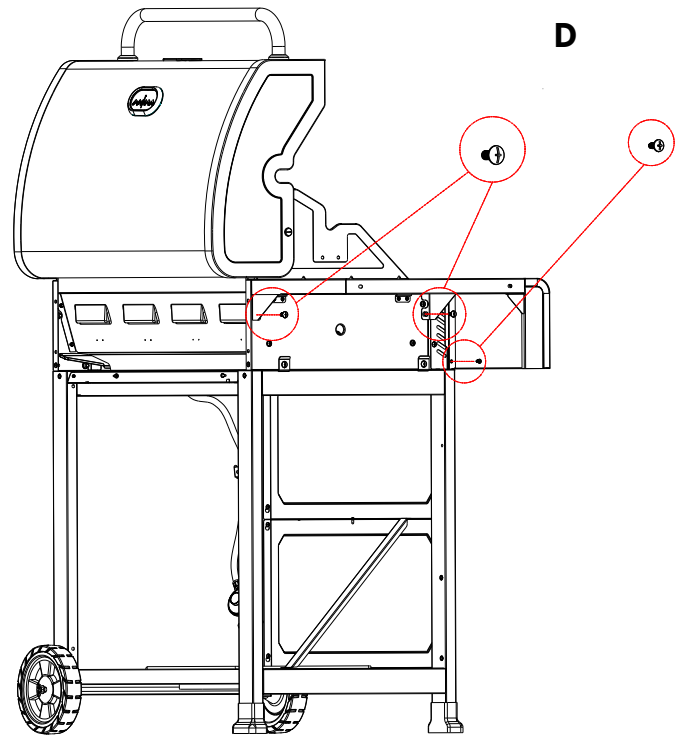
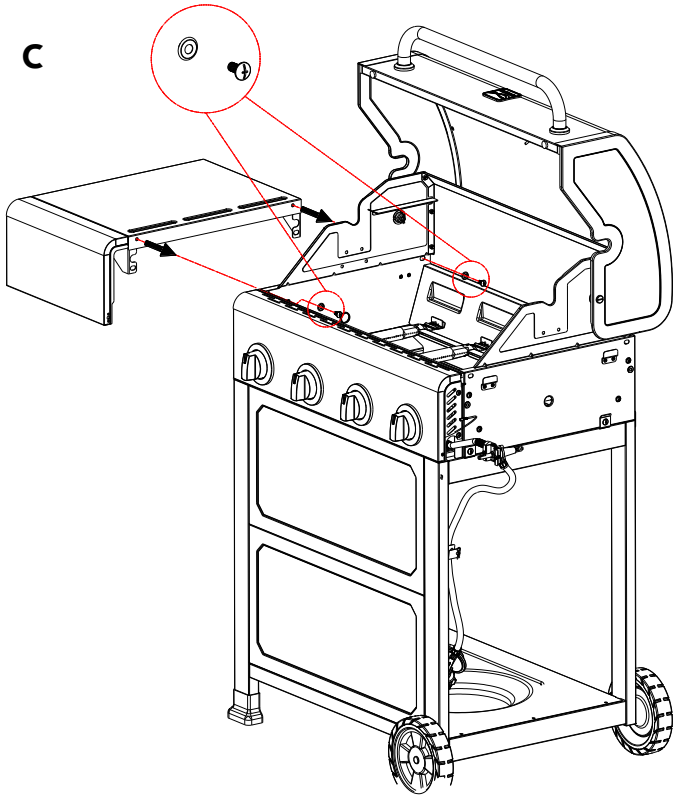
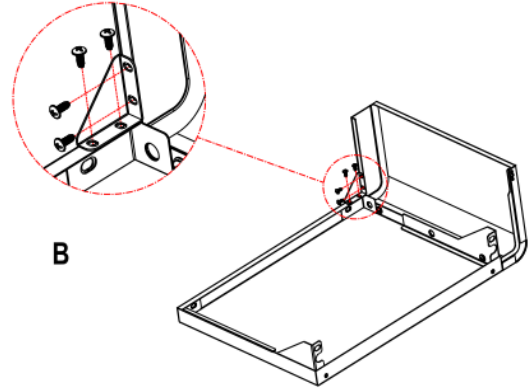
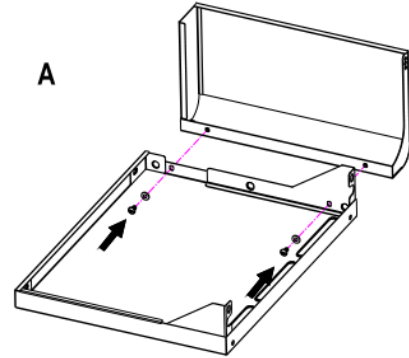

8

Right Side Shelf

- Remove side burner grate from side burner before assembling and attaching the right side shelf,
- Attach fascia to right side shelf with (2) M5x10 screws and M5 flat washers.(A)
- Attach Side Shelf Support Angle Bar with (4) M4x10 screws.(B)
- Hang right side shelf onto the brackets on right side of firebox.
- Attach shelf to firebox as follows:
 - From inside to outside of firebox with (2) M6x13 screws and M6 compression washers.(C)
 - From outside to inside of firebox with (2) M6x13 screws. (D)
- Attach fascia to control panel with M4x10 screw. (D)



M5X10 screw Qty: 2 pcs



M5 flat washer Qty: 2 pcs

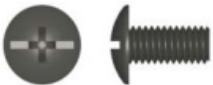

M6X13 screws Qty: 4 pcs



M6 compression washer Qty: 2 pcs



M4X10 screw Qty: 5 pcs

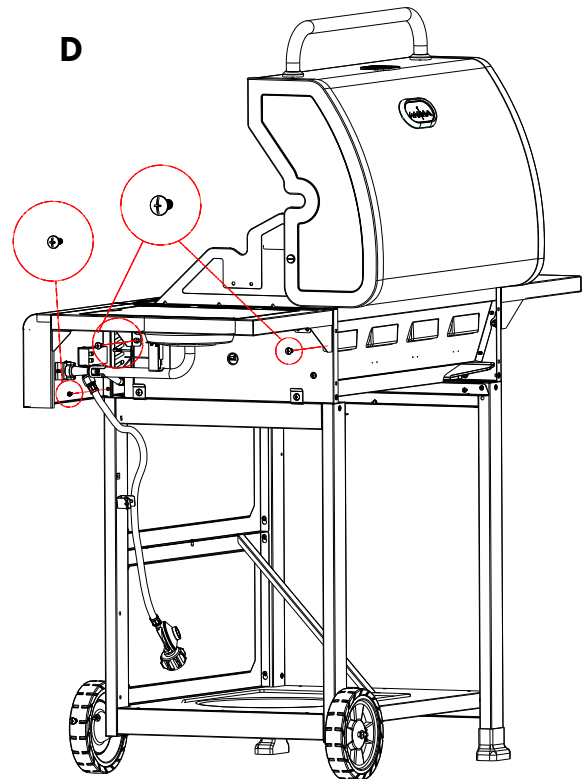
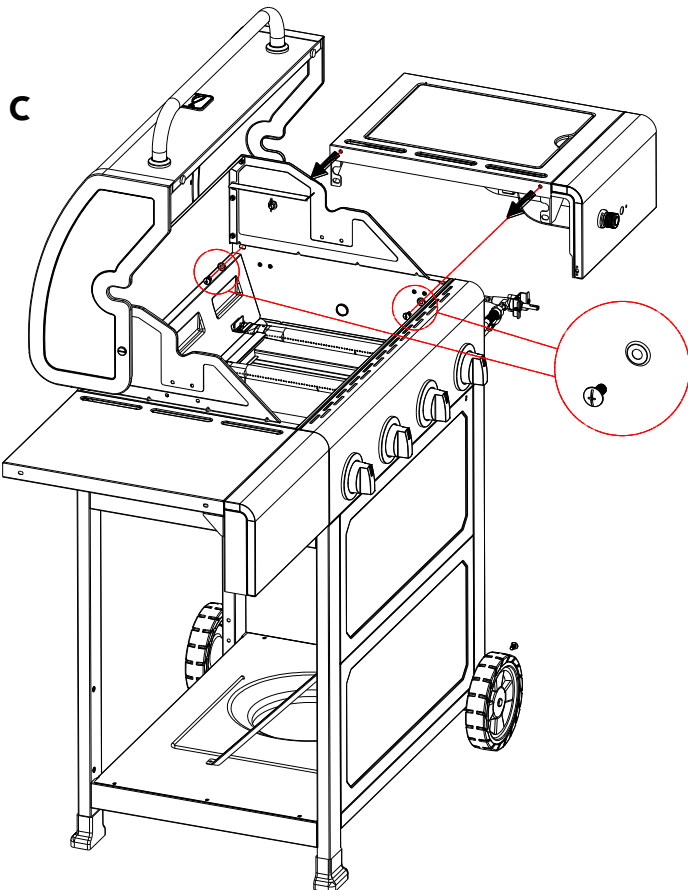
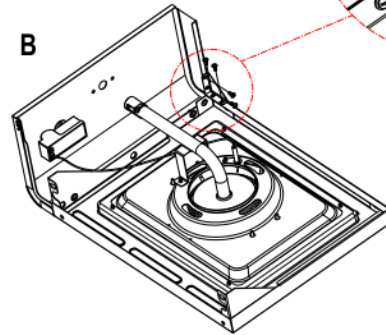
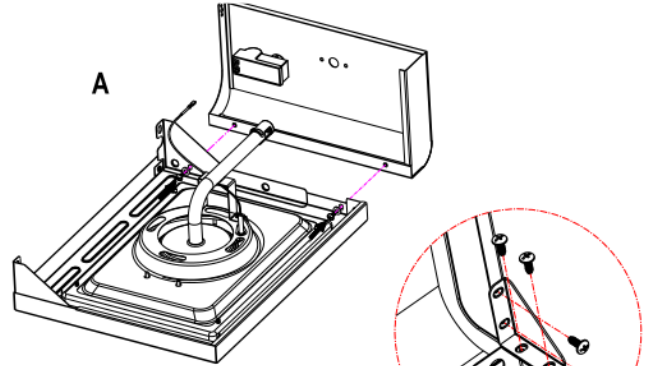

9

Side burner

- Loosen side burner in side shelf. (B). To loosen, unscrew and remove two front screws and washers holding sideburner in place. (A). Note: Do not loosen electrode screw.
- Remove the 2 pre-installed screws from the valve stem and set them aside. (C)
- Insert valve stem through hole in fascia. (D). Install previously removed 2 screws .Note: Leave a 1/8-inch gap below the screw heads for bezel attachment. (E).
- Attach bezel to fascia and valve face with the installed screws. Make sure the white mark is facing up.(F). Tighten the 2 screws.(G)
- Place sideburner tube over the valve, making sure that valve is inside sideburner tube. (H)
- Push control knob onto sideburner valve stem. (I)
- Reattach sideburner to sideburner shelf with the 2 previously removed screws. Replace sideburner grate. (J)
- Connect both igniter wires to the igniter module on the inside of the right fascia. To connect, push igniter wire tips onto pins in igniter module.(K)
- Unscrew igniter cap from control panel. Insert (1) AA battery (provided in blister pack) into battery slot with positive end (+) facing outward. Screw igniter cap back onto panel. (L)



10

Heat Diffusers, Cooking Grates and Warming Rack

- Place Heat Diffusers over burners. Diffusers will fit in firebox in either direction.
- Place Cooking Grates onto grate rests at front and rear of Firebox.
- Insert warming rack into brackets at top of Firebox with Curved edge to front as shown.

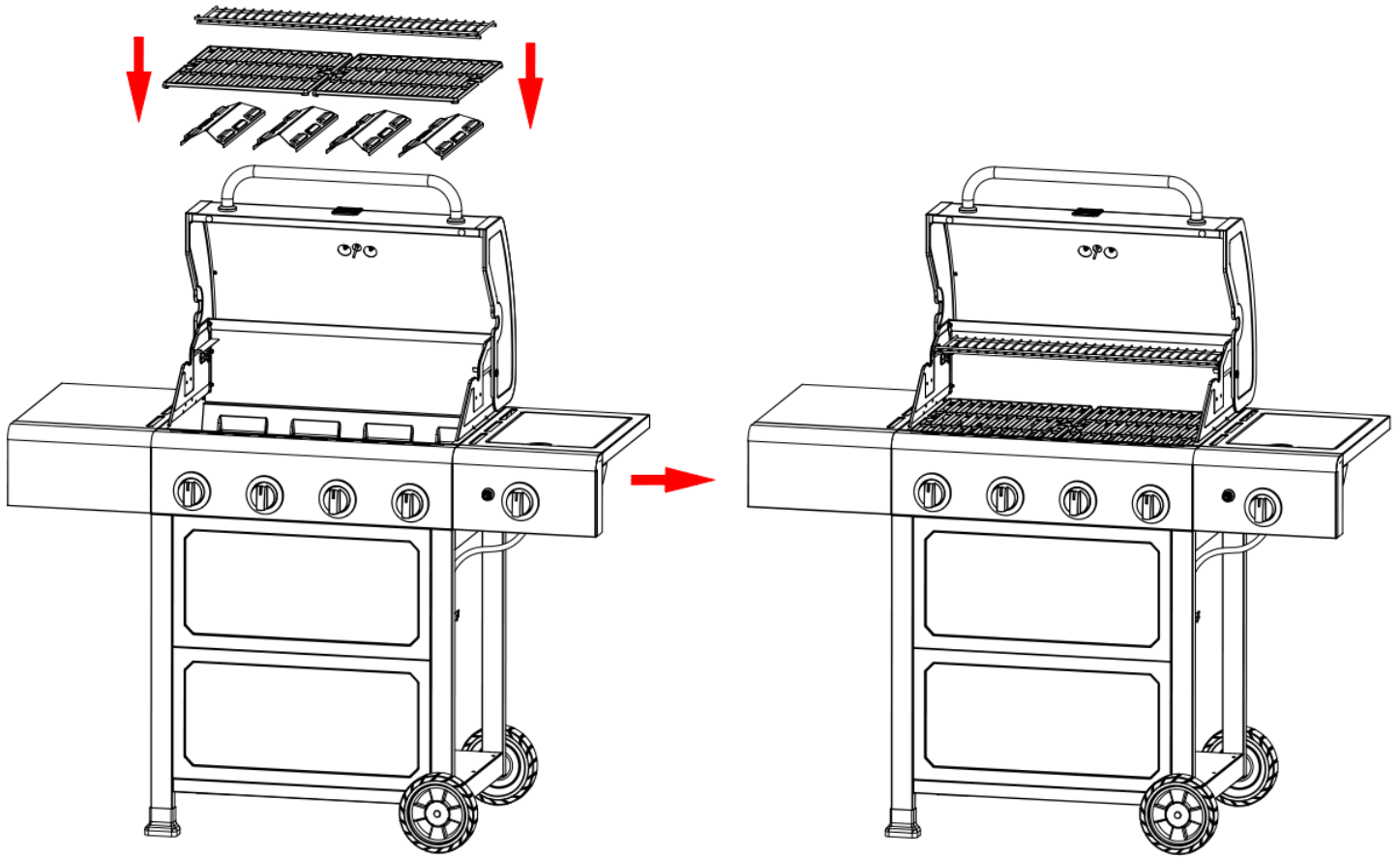

11

Drip Tray, Drip Cup and LP Tank

- Attach Back Rail to the Cart and Grill Head with (4)M4 × 10 Screws as shown.(A)
- Remove the cotter key and retention pin from the hose bracket on cart right leg. Insert hose into bracket and replace cotter and pin.
- Hang Drip Cup Clip from bottom of drip tray, and insert Drip Tray into bottom of Firebox from back of cart. Fit Drip Cup into Drip Cup Clip. Insert Match Holder Chain into hole in Front Left Leg. (B)
- Place LP tank into hole in bottom shelf with tank collar opening facing to side as shown.(C)



M4X10 screw Qty: 4 pcs

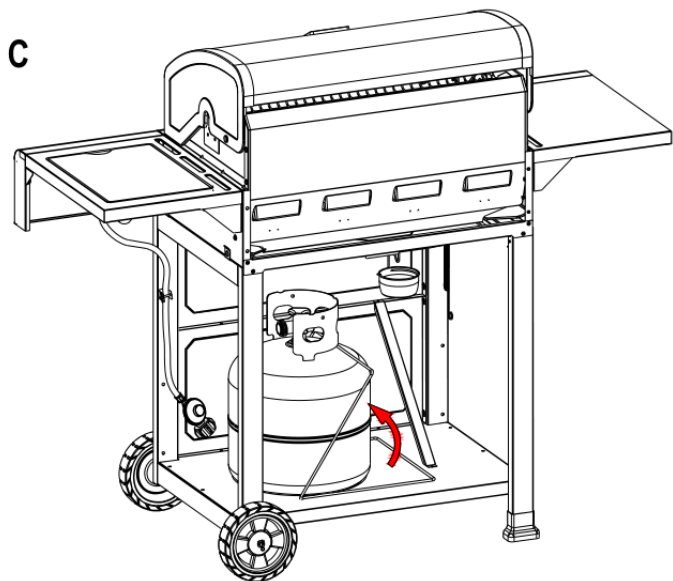
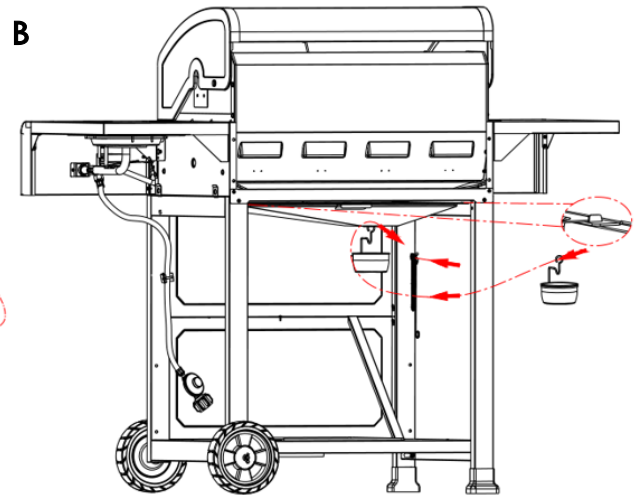
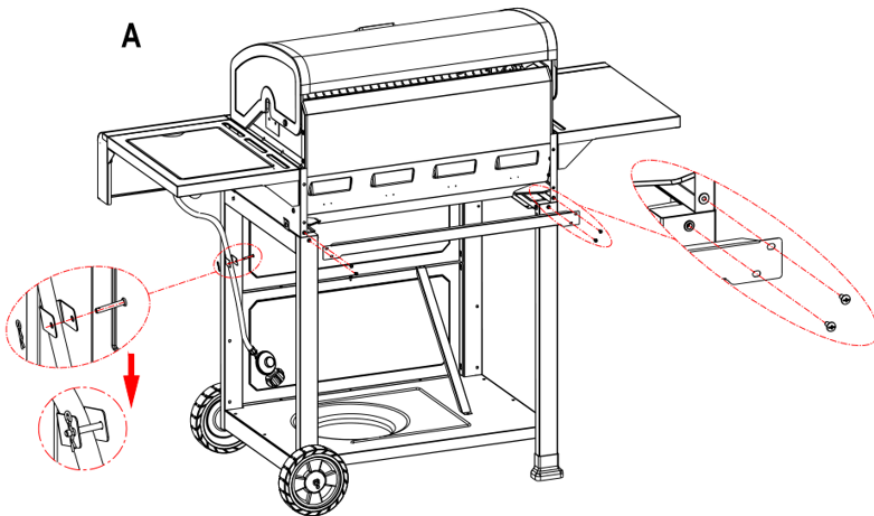

EMERGENCIES: If a gas leak cannot be stopped, or a fire occurs due to gas leakage, call the fire department.

Problem	Possible Cause	Prevention/Solution
Gas leaking from cracked/cut/burned hose.	<ul style="list-style-type: none"> Damaged hose. 	<ul style="list-style-type: none"> Turn off gas at LP cylinder or at source on natural gas systems. If the hose is cracked or cut but not burned, simply replace valve / hose / regulator. If the hose is burned, the cause could be other than a faulty valve/hose/regulator. Discontinue use of grill until a plumber or gas technician has investigated and corrected the problem.
Gas leaking from LP cylinder.	<ul style="list-style-type: none"> Mechanical failure due to rusting or mishandling. 	<ul style="list-style-type: none"> Replace LP cylinder.
Gas leaking from LP cylinder valve.	<ul style="list-style-type: none"> Failure of cylinder valve from mishandling or mechanical failure. 	<ul style="list-style-type: none"> Turn off LP cylinder valve. Return LP cylinder to gas supplier.
Gas leaking between LP cylinder and regulator connection.	<ul style="list-style-type: none"> Improper installation, connection not tight, failure of rubber seal. 	<ul style="list-style-type: none"> Turn off LP cylinder valve. Remove regulator from cylinder and visually inspect rubber seal for damage. See LP Cylinder Leak Test and Connecting Regulator to the LP Cylinder.
Fire coming through control panel.	<ul style="list-style-type: none"> Fire in burner tube section of burner due to blockage. 	<ul style="list-style-type: none"> Turn off control knobs and LP cylinder valve. Leave lid open to allow flames to die down. After fire is out and grill is cold, remove burner and inspect for spider nests or rust. See Spider Alert and Cleaning the Burner Assembly sections of this Use & Care Guide.
Drip fire or continuous excessive flames above cooking surface.	<ul style="list-style-type: none"> Too much drip buildup in burner area. 	<ul style="list-style-type: none"> Turn off control knobs and LP cylinder valve. Leave lid open to allow flames to die down. After cooling, clean food particles and excess drip from inside firebox area, drip tray, and other surfaces.

Troubleshooting

Problem	Possible Cause	Prevention/Solution
<p>Burner(s) will not light using igniter. (See Electronic Ignition Troubleshooting also)</p> <p>Continued on next page.</p>	<p>GAS ISSUES:</p> <ul style="list-style-type: none"> Trying to light wrong burner. Burner not engaged with control valve. Obstruction in burner. No gas flow. Vapor lock at coupling nut to LP cylinder. Coupling nut and LP cylinder valve not fully connected. <p>ELECTRICAL ISSUES:</p> <ul style="list-style-type: none"> Electrode cracked or broken; "sparks at crack. Electrode tip not in proper position. Wire and/or electrode covered with cooking residue. Wires are loose or disconnected. Wires are shorting (sparking) between igniter and electrode. Dead battery. 	<ul style="list-style-type: none"> See instructions on control panel and in Use and Care section. Make sure valves are positioned inside of burner tubes. Ensure burner tubes are not obstructed with spider webs or other matter. See cleaning section of Use and Care. Make sure LP cylinder is not empty. If LP cylinder is not empty, refer to "Sudden drop in gas flow." Turn off knobs and disconnect coupling nut from LP cylinder. Reconnect and retry. Turn the coupling nut approximately one-half to three-quarters additional turn until solid stop. Tighten by hand only - do not use tools. Replace electrode(s). <p>Main Burners:</p> <ul style="list-style-type: none"> Tip of electrode should be pointing toward gas port opening on burner. The distance should be 1/8" to 1/4". Adjust if necessary. <p>Sideburner</p> <ul style="list-style-type: none"> Tip of electrode should be pointing toward gas port opening on burner. the distance should be 1/8" to 3/16". Adjust if necessary. Clean wire and/or electrode with rubbing alcohol and clean swab. Reconnect wires or replace electrode/wire assembly. Replace igniter wire/electrode assembly. Replace with a new AA-size alkaline battery.

Troubleshooting (continued)

Problem	Possible Cause	Prevention/Solution
Burner(s) will not light using igniter. (See Electronic Ignition Troubleshooting also)	ELECTRONIC IGNITION: <ul style="list-style-type: none"> • No spark, no ignition noise. • No spark, some ignition noise. • Sparks, but not at electrode or at full strength. 	<ul style="list-style-type: none"> • See Section I of Electronic Ignition System. • See Section II of Electronic Ignition System. • See Section III of Electronic Ignition System.
Burner(s) will not match light.	<ul style="list-style-type: none"> • See "GAS ISSUES:" on previous page. • Match will not reach. • Improper method of match-lighting. 	<ul style="list-style-type: none"> • Use long-stem match (fireplace match). • See "Match-Lighting" section of Use and Care.
Sudden drop in gas flow or low flame.	<ul style="list-style-type: none"> • Out of gas. • Excess flow valve tripped. • Vapor lock at coupling nut/LP cylinder connection. 	<ul style="list-style-type: none"> • Check for gas in LP cylinder. • Turn off knobs, wait 30 seconds and light grill. If flames are still low, turn off knobs and LP cylinder valve. Disconnect regulator. Reconnect regulator and leak-test. Turn on LP cylinder valve, wait 30 seconds and then light grill. • Turn off knobs and LP cylinder valve. Disconnect coupling nut from cylinder. Reconnect and retry.
Flames blow out.	<ul style="list-style-type: none"> • High or gusting winds. • Low on LP gas. • Excess flow valve tripped. 	<ul style="list-style-type: none"> • Turn front of grill to face wind or increase flame height. • Refill LP cylinder. • Refer to "Sudden drop in gas flow" above.
Flare-up.	<ul style="list-style-type: none"> • Drip buildup. • Excessive fat in meat. • Excessive cooking temperature. 	<ul style="list-style-type: none"> • Clean burners and inside of grill/firebox. • Trim fat from meat before grilling. • Adjust (lower) temperature accordingly.
Persistent drip fire	<ul style="list-style-type: none"> • Drip trapped by food buildup around burner system. 	<ul style="list-style-type: none"> • Turn knobs to OFF. Turn gas off at LP cylinder. Leave lid in position and let fire burn out. After grill cools, remove and clean all parts.
Flashback... (fire in burner tube(s))	<ul style="list-style-type: none"> • Burner and/or burner tubes are blocked. 	<ul style="list-style-type: none"> • Turn knobs to OFF. Clean burner and/or burner tubes. See burner cleaning section of Use and Care.
Unable to fill LP cylinder.	<ul style="list-style-type: none"> • Some dealers have older fill nozzles with worn threads. 	<ul style="list-style-type: none"> • The worn nozzles don't have enough "bite" to engage the valve. Try a second LP dealer.
One burner does not light from other burner(s).	<ul style="list-style-type: none"> • Drip buildup or food particles in end(s) of carryover tube(s). 	<ul style="list-style-type: none"> • Clean carry-over tube(s) with wire brush.

Troubleshooting - Electronic Ignition

Problem (Ignition)	Possible Cause	Check Item	Prevention/Solution
<p>SECTION I No sparks appear at any electrodes when control knob turned to HI: no noise can be heard from spark module.</p>	<ul style="list-style-type: none"> • Battery not installed properly. • Dead battery. • Button assembly not installed properly. • Faulty spark module 	<ul style="list-style-type: none"> • Check battery orientation. • Has battery been used previously? • Check to insure threads are properly engaged. Button should travel up and down without binding. • If no sparks are generated with new battery and good wire connections, module is faulty. 	<ul style="list-style-type: none"> • Install battery (make sure that "+" and "-" connectors are oriented correctly, with "+" end up and "-" end down.) • Replace battery with new AA-size alkaline battery. • Unscrew button cap assembly and reinstall, making sure threads are aligned and engaged fully. • Replace spark module assembly.
<p>SECTION II No sparks appear at any electrodes when control knob turned to HI; noise can be heard from spark module.</p>	<ul style="list-style-type: none"> • Output lead connections not connected. 	<ul style="list-style-type: none"> • Are output connections on and tight? 	<ul style="list-style-type: none"> • Remove and reconnect all output connections at module and electrodes.
<p>SECTION III Sparks are present but not at all electrodes and/or not at full strength</p>	<ul style="list-style-type: none"> • Output lead connections not connected. • Electrical arc between output wires and grill frame. • Weak battery. • Electrodes are wet. • Electrode (s) cracked or broken; sparks appear where cracked. 	<ul style="list-style-type: none"> • Are output connections on and tight? • If possible, observe grill in dark location. Operate ignition system and look for arcing between output wires and grill frame. • All sparks present but weak or at slow rate. • Has moisture accumulated on electrode and/or in burner ports? • Inspect electrodes for cracks. 	<ul style="list-style-type: none"> • Remove and reconnect all output connections at module and electrodes. • If sparks are observed other than from burner (s), wire insulation may be damaged. Replace wires. • Replace battery with a new AAA-size alkaline battery. • Use paper towel to remove moisture. • Replace cracked or broken electrodes.

Kenmore®

Customer Care Hotline

To schedule in-home repair service
or order replacement parts

Para pedir servicio de reparación
a domicilio, y ordenar piezas

1-844-553-6667

www.kenmore.com

