



DISTINCT BY DESIGN™

## Owner's Manual and Installation Instructions

### Bottom Freezer Refrigerators

Models: CWE19S (Counter Depth Models)  
CFE26K (Standard Depth Models)

#### Contents

|                                     |    |   |    |
|-------------------------------------|----|---|----|
| <b>Safety Information</b> . . . . . | 3  | <b>Installation Instructions</b>                |    |
| <b>Using the Refrigerator</b>       |    | Preparing to Install the Refrigerator . . . . . | 16 |
| Features . . . . .                  | 5  | Appliance Dimensions . . . . .                  | 17 |
| Controls . . . . .                  | 6  | Installing the Refrigerator . . . . .           | 18 |
| Dispenser . . . . .                 | 8  | Installing the Water Line . . . . .             | 28 |
| Water Filter - XWF . . . . .        | 9  | <b>Troubleshooting Tips</b> . . . . .           | 31 |
| Shelves and Bins . . . . .          | 10 | <b>Limited Warranty</b> . . . . .               | 35 |
| Pans . . . . .                      | 11 | <b>Consumer Support</b>                         |    |
| Freezer Drawer . . . . .            | 12 | Water Filter Warranty . . . . .                 | 36 |
| Automatic Icemaker . . . . .        | 13 | Performance Data Sheets . . . . .               | 37 |
| <b>Care And Cleaning</b> . . . . .  | 14 | Consumer Support . . . . .                      | 40 |
| Replacing the Lights . . . . .      | 15 |   |    |

Write the model and serial numbers here:

Model # \_\_\_\_\_

Serial # \_\_\_\_\_

Find these numbers on a label on the left side, near the middle of the refrigerator compartment.

**ENGLISH/FRANÇAIS/ESPAÑOL**

## THANK YOU FOR MAKING CAFÉ A PART OF YOUR HOME.

---

We take pride in the craftsmanship, innovation and design that goes into every Café product, and we think you will too. Among other things, registration of your appliance ensures that we can deliver important product information and warranty details when you need them.

Register your Café appliance now online. Helpful websites are available in the Consumer Support section of this Owner's Manual. You may also mail in the pre-printed registration card included in the packing material.

**C A F É**

---

DISTINCT BY DESIGN™

# IMPORTANT SAFETY INFORMATION

## READ ALL INSTRUCTIONS BEFORE USING THE APPLIANCE

**⚠ WARNING** To reduce the risk of fire, explosion, electric shock, or injury when using your refrigerator, follow these basic safety precautions:

- This refrigerator must be properly installed and located in accordance with the Installation Instructions before it is used.
- Unplug the refrigerator before making repairs or cleaning.
 

**NOTE:** Power to the refrigerator cannot be disconnected by any setting on the control panel.

**NOTE:** Repairs must be performed by a qualified Service Professional.
- Replace all parts and panels before operating.
- Do not use an extension cord.
- Do not store or use gasoline or other flammable vapors and liquids in the vicinity of this or any other appliance.
- Do not store explosive substances such as aerosol cans with a flammable propellant in this appliance.
- To prevent suffocation and entrapment hazards to children, remove the fresh food and freezer doors from any refrigerator before disposing of it or discontinuing its use.
- To avoid serious injury or death, children should not stand on, or play in or with the appliance.
- Children and persons with reduced physical, sensory or mental capabilities or lack of experience and knowledge can use this appliance only if they are supervised or have been given instructions on safe use and understand the hazards involved.
- This appliance is intended to be used in household and similar applications such as: staff kitchen areas in shops, offices and other working environments; farm houses; by clients in hotels, motels, bed & breakfast and other residential environments; catering and similar non-retail applications.
- Connect to potable water supply only. A cold water supply is required for automatic icemaker operation. The water pressure must be between 40 and 120 psi (275-827 kilopascals).
- Do not apply harsh cleaners to the refrigerator. Certain cleaners will damage plastic which may cause parts such as the door or door handles to detach unexpectedly. See the Care and Cleaning section for detailed instructions.

**⚠ CAUTION** To reduce the risk of injury when using your refrigerator, follow these basic safety precautions.

- Do not clean glass shelves or covers with warm water when they are cold. Glass shelves and covers may break if exposed to sudden temperature changes or impact, such as bumping or dropping. Tempered glass is designed to shatter into many small pieces if it breaks.
- Keep fingers out of the “pinch point” areas; clearances between the doors and between the doors and cabinet are necessarily small. Be careful closing doors when children are in the area.
- Do not touch the cold surfaces in the freezer compartment when hands are damp or wet, skin may stick to these extremely cold surfaces.
- Do not refreeze frozen foods which have thawed completely.
- In refrigerators with automatic icemakers, avoid contact with the moving parts of the ejector mechanism, or with the heating element that releases the cubes. Do not place fingers or hands on the automatic ice making mechanism while the refrigerator is plugged in.
- Use a sturdy glass when dispensing ice (on models with ice dispenser)

## INSTALLATION

**⚠ WARNING**  **EXPLOSION HAZARD**

Keep flammable materials and vapors, such as gasoline, away from refrigerator. Failure to do so can result in fire, explosion, or death.

# READ AND SAVE THESE INSTRUCTIONS

# IMPORTANT SAFETY INFORMATION

## READ ALL INSTRUCTIONS BEFORE USING THE APPLIANCE

### CONNECTING ELECTRICITY

#### **⚠ WARNING** **ELECTRICAL SHOCK HAZARD**

Plug into a grounded 3-prong outlet  
 Do not remove the ground prong  
 Do not use an adapter  
 Do not use an extension cord.  
 Failure to follow these instructions can result in death, fire, or electrical shock.

**Do not, under any circumstances, cut or remove the third (ground) prong from the power cord. For personal safety, this appliance must be properly grounded.**

The power cord of this appliance is equipped with a 3-prong (grounding) plug which mates with a standard 3-prong (grounding) wall outlet to minimize the possibility of electric shock hazard from this appliance.

Have the wall outlet and circuit checked by a qualified electrician to make sure the outlet is properly grounded.

Where a standard 2-prong wall outlet is encountered, it is your personal responsibility and obligation to have it replaced with a properly grounded 3-prong wall outlet. Do not use an adapter.

The refrigerator should always be plugged into its own individual electrical outlet which has a voltage rating that matches the rating plate.

A 115 Volt AC, 60 Hz, 15- or 20-amp fused, grounded electrical supply is required. This provides the best performance and also prevents overloading house wiring circuits which could cause a fire hazard from overheated wires.

Never unplug your refrigerator by pulling on the power cord. Always grip plug firmly and pull straight out from the outlet.

Immediately discontinue use of a damaged supply cord. If the supply cord is damaged, it must be replaced by a qualified service professional with an authorized service part from the manufacturer.

When moving the refrigerator away from the wall, be careful not to roll over or damage the power cord.

### PROPER DISPOSAL OF YOUR OLD REFRIGERATOR

#### **⚠ WARNING** **SUFFOCATION AND ENTRAPMENT HAZARD**

Failure to follow these disposal instructions can result in death or serious injury

**IMPORTANT:** Child entrapment and suffocation are not problems of the past. Junked or abandoned refrigerators are still dangerous even if they will sit for “just a few days.” If you are getting rid of your old refrigerator, please follow the instructions below to help prevent accidents.

#### **Before You Throw Away Your Old Appliance**

- Take off the fresh food and freezer doors.
- Leave the shelves in place so that children may not easily climb inside.

#### **Refrigerant and Foam Disposal:**

Dispose of appliance in accordance with Federal and Local Regulations. Flammable insulation material used requires special disposal of your appliance. Contact your local authorities for the environmentally safe disposal of your appliance.

## READ AND SAVE THESE INSTRUCTIONS

# Features

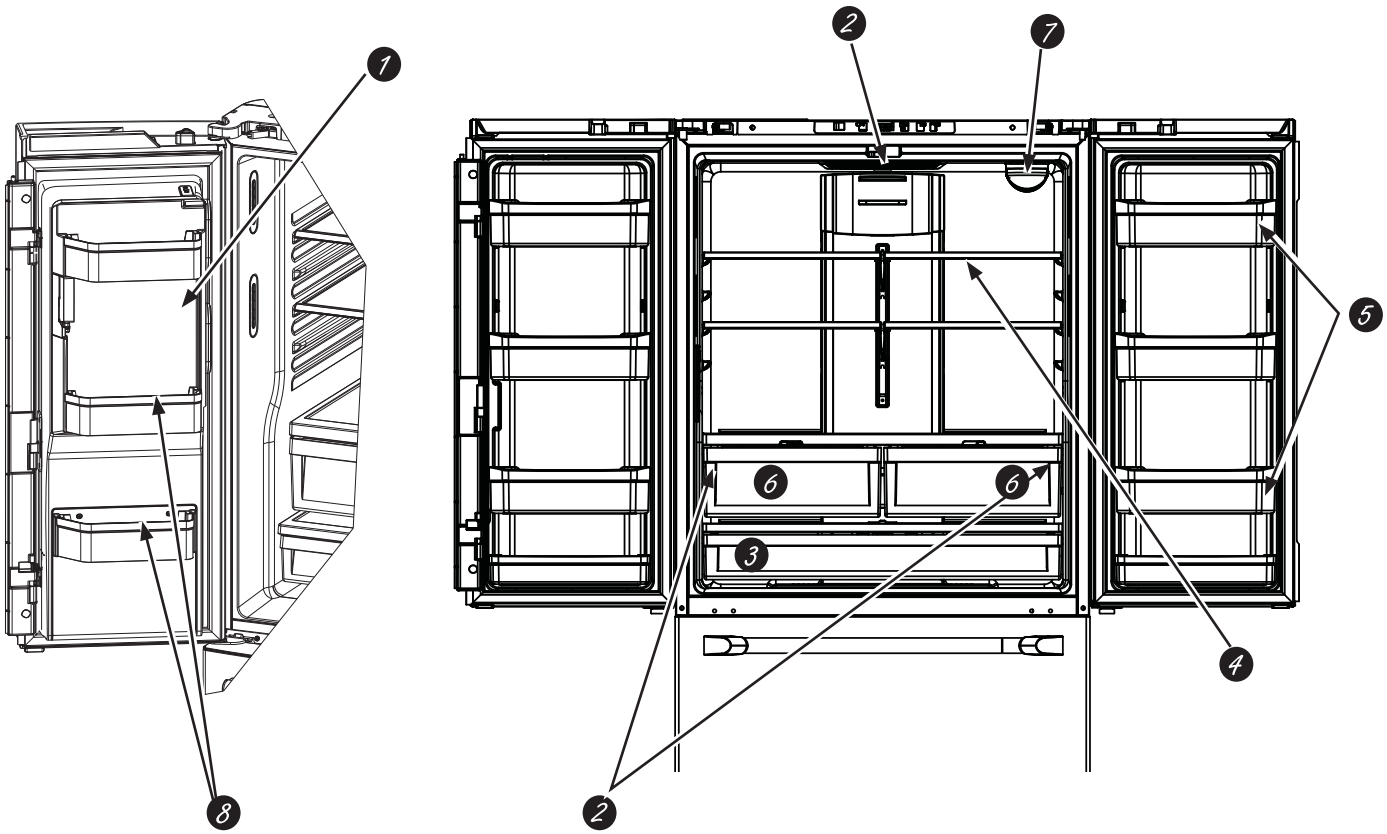

- 1 Space-saving icemaker (on some models)**  
Icemaker and bin are located on the door creating more usable storage space.
- 2 LED lighting**  
LED lights in the fresh food compartment are located at the top center and on the left and right sides of climate zone pans. LED lights are also located in the freezer; see page 15.
- 3 Full-width drawer**  
A full-width drawer that can accommodate larger items is located at the bottom of the fresh food compartment.
- 4 QuickSpace™ shelf (on some models)**  
Functions as a normal full-sized shelf when needed and easily slides back to store tall items below.

- 5 Removable/adjustable door bins**  
Can be moved up or down to accommodate your needs.
- 6 Climate zone drawers**  
Separate pans for produce storage.
- 7 Water filter**  
Accessible for easy replacement.
- 8 Anti-slip Mat**  
Liner that captures spills, keeps containers from shifting when the door is opened and is easily removable for cleaning.

# Controls

## CWE19S Top Control Models

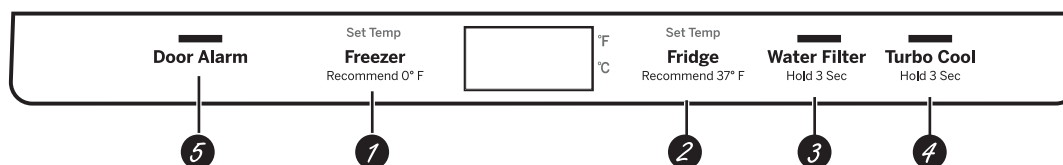

- 1 Freezer Compartment Temperature Control**  
 Adjust freezer compartment temperature. The freezer temperature is preset in the factory at **0°F (-17.8°C)**. Allow 24 hours for temperature to stabilize to the preset recommended setting.
- 2 Fresh Food Compartment Temperature Control**  
 Adjust fresh food compartment temperature. The fresh food temperature is preset in the factory at **37°F (2.8°C)**. Allow 24 hours for temperature to stabilize to the preset recommended setting.
- 3 Water Filter**  
 Press and hold 3 seconds to reset the Water Filter.
- 4 Turbo Cool**  
 To set the **TurboCool™**, press the **Turbo Cool** pad for 3 seconds. The display will show **tc**. **TurboCool™** rapidly cools the refrigerator compartment in order to more quickly cool foods. Use **TurboCool™** when adding a large amount of the food to the refrigerator compartment, putting away foods after they have been sitting out at room temperature, or when putting away warm leftovers. It can also be used if the refrigerator has been without power for an extended period.

**NOTE:** The refrigerator temperature cannot be changed during **TurboCool™**. The freezer temperature is not affected during **Turbo Cool**. When opening the refrigerator door during **TurboCool™**, the fans will continue to run if they have cycled on.

- 5 Door Alarm**  
 To set the alarm, press the **Door Alarm** pad. This alarm will sound if either door is open for more than 2 minutes. The beeping stops when you close the door.

**NOTE:** To put the refrigerator control in the **OFF** position, simultaneously touch the words **Freezer** and **Fridge** for 3 seconds. Power to the refrigerator cannot be disconnected by any setting on the control panel.

**Changing °F to °C or °C to °F:** Press and hold the "DOOR ALARM" and "FREEZER" buttons simultaneously for 5 seconds to set °C to °F or °F to °C.

**NOTE:** The refrigerator is shipped with protective film covering the temperature controls. If this film was not removed during installation, remove it now.

## CFE26K External Control Model

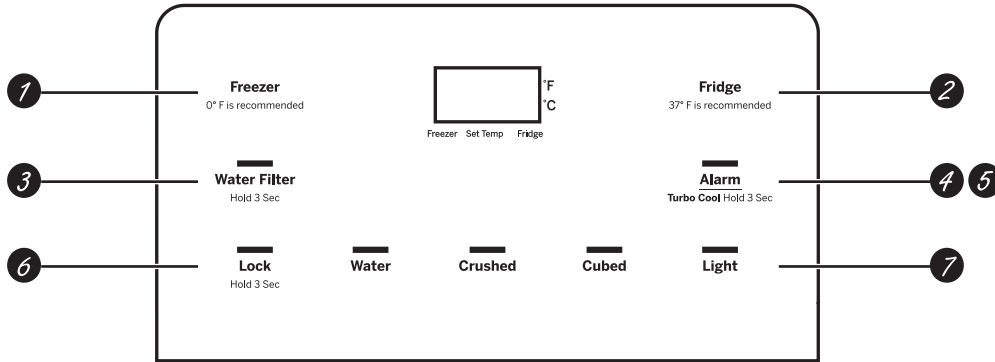

- 1 Freezer Compartment Temperature Control**  
Adjust freezer compartment temperature. The freezer temperature is preset in the factory at **0°F (-17.8°C)**. Allow 24 hours for temperature to stabilize to the preset recommended setting.
- 2 Fresh Food Compartment Temperature Control**  
Adjust fresh food compartment temperature. The fresh food temperature is preset in the factory at **37°F (2.8°C)**. Allow 24 hours for temperature to stabilize to the preset recommended setting.
- 3 Water Filter**  
Press and hold 3 seconds to reset the Water Filter.
- 4 Turbo Cool**  
To set the **Turbo Cool™**, press the **Alarm** pad for 3 seconds. The display will show **tc**. **Turbo Cool™** rapidly cools the refrigerator compartment in order to more quickly cool foods. Use **Turbo Cool™** when adding a large amount of the food to the refrigerator compartment, putting away foods after they have been sitting out at room temperature, or when putting away warm leftovers. It can also be used if the refrigerator has been without power for an extended period.

- NOTE:** The refrigerator temperature cannot be changed during **Turbo Cool™**. The freezer temperature is not affected during **Turbo Cool**. When opening the refrigerator door during **Turbo Cool™**, the fans will continue to run if they have cycled on.
- 5 Alarm**  
Press the **Alarm** pad to toggle the door alarm between off and on. The alarm will sound if either door is left open for more than 2 minutes. The beeping stops when you close the door.
  - 6 Lock**  
Press and hold the **Lock** pad for 3 seconds to lock out ice and water dispenser and all other controls. Press and hold to unlock the controls.
  - 7 LED dispenser Light**  
Press the **Light** pad to turn your dispenser light on and off.
- NOTE:** To put the refrigerator control in the **OFF** position, simultaneously touch the words **Freezer** and **Fridge** for 3 seconds. Power to the refrigerator cannot be disconnected by any setting on the control panel.

**Changing °F to °C or °C to °F:** Press and hold the "FREEZER" and "ALARM" buttons simultaneously for 5 seconds to set °C to °F or °F to °C.

**NOTE:** The refrigerator is shipped with protective film covering the temperature controls. If this film was not removed during installation, remove it now.

## Sabbath Modes (on some models)

### Models CWE19S controls

- Press and hold the "DOOR ALARM" and "WATER FILTER" buttons simultaneously for 5 seconds to enter/exit Sabbath Mode.
- The icemaker must be turned off manually during Sabbath Mode. Set the Power Switch to OFF. To turn the icemaker back on, set the Power Switch to ON.

### Model CFE26K controls

- Press and hold the "LOCK" and "LIGHT" buttons simultaneously for 5 seconds to enter/exit Sabbath Mode.
- The icemaker must be turned off manually during Sabbath Mode. Set the Power Switch to OFF. To turn the icemaker back on, set the Power Switch to ON.

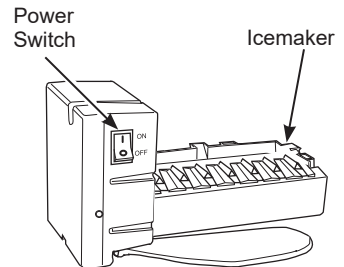



## Dispenser (on some models)

### Water & Ice Dispenser

(See Controls)

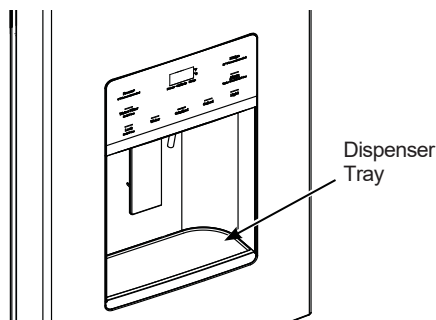

Press the glass gently against the dispenser cradle.

The spill shelf is not self-draining. To reduce water spotting, the shelf should be cleaned regularly.

If no water is dispensed when the refrigerator is first installed, there may be air in the water line system. Press the dispenser paddle for at least five minutes to remove trapped air from the water line and to fill the water system. To flush out impurities in the water line, throw away the first six full glasses of water.

#### **CAUTION** Laceration Hazard

- Never put fingers or any other object into ice crusher discharge opening. Doing so can result in contacting the ice crushing blades and lead to serious injury or amputation
- Use a sturdy glass when dispensing ice. A delicate glass may break and result in personal injury.

#### To remove Dispenser Tray

- Pull Dispenser Tray out.

#### To reinstall Dispenser Tray

- Push in until it is firmly in place.

### Door Ice Bin

1. Open left fresh food door.
2. Pull down latch to release bin door.
3. Using handhold, lift ice bucket up and out to clear locators in bottom of bin.
4. To replace the ice bucket, set it on the guide brackets and push until the ice bucket seats properly.
5. If bucket cannot be replaced, rotate the Ice Bucket Fork 1/4 turn clockwise.

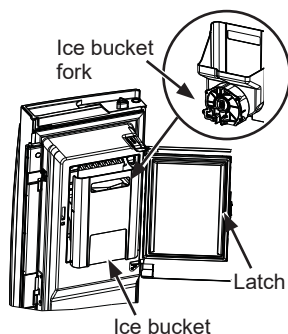

### Internal Water Dispenser

(on some models)

The water dispenser is located on the left wall inside the refrigerator compartment.

#### To dispense water:

1. Hold the glass against the recess.
2. Push the water dispenser button.
3. Hold the glass underneath the dispenser for 2–3 seconds after releasing the dispenser button. Water may continue to dispense after the button is released.

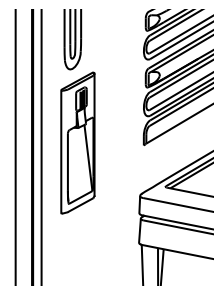

If no water is dispensed when the refrigerator is first installed, there may be air in the water line system. Press the dispenser button for at least 5 minutes to remove trapped air from the water line and to fill the water system. During this process, the dispenser noise may be loud as the air is purged from the water line system. To flush out impurities in the water line, throw away the first 6 glassfuls of water.

**NOTE:** To avoid water deposits, the dispenser should be cleaned periodically by wiping with a clean cloth or sponge.

### Important Facts About Your Dispensers

- Do not add ice from trays or bags to the door icemaker bucket. It may not crush or dispense.
- Avoid overfilling glass with ice and use of narrow glasses. Backed-up ice can jam the chute or cause the door in the chute to freeze shut. If ice is blocking the chute remove the ice bucket, poke it through with a wooden spoon.
- Beverages and foods should not be quick-chilled in the door icemaker bin. Cans, bottles or food packages in the storage drawer may cause the icemaker or auger to jam.
- To keep dispensed ice from missing the glass, put the glass close to, but not touching, the dispenser opening.
- Some crushed ice may be dispensed even though you selected **CUBED ICE**. This happens occasionally when a few cubes accidentally get directed to the crusher.
- After crushed ice is dispensed, some water may drip from the chute.
- Sometimes a small mound of frost will form on the door in the ice chute. This condition is normal and usually occurs when you have dispensed crushed ice repeatedly.



# Water Filter Cartridge - XWF (on some models)

## Water Filter Cartridge

The water filter cartridge holder is located in the back upper-right corner of the fresh food refrigerator compartment.

## When to Replace the Filter

If there is a replacement indicator light for the water filter cartridge on the dispenser, the red filter light will start blinking to tell you that you need to replace the filter soon.

- For external control models, the filter light will blink while you are dispensing until the filter is replaced.
- For top control models, the filter light will blink while the door is open until the filter is replaced.

For models that don't have the indicator light, the filter cartridge should be replaced every six months, or earlier if the flow of water to the dispenser or icemaker decreases.

## Removing the Filter

If you are replacing the filter, first remove the previous one:

1. Open the filter cartridge housing by squeezing the 2 front tabs and gently pulling down.
2. Rotate the filter down.
3. Gently grasp the filter and slowly turn it counterclockwise about a ¼ turn. The filter should automatically release itself when you have rotated it far enough to the left. A small amount of water may drip down.

### ⚠ CAUTION

If air has been trapped in the system, the filter cartridge may be ejected as it is removed. Use caution when removing.

## Filter Bypass Plug

To reduce the risk of property damage due to water leakage, you **MUST** use the filter bypass plug when a replacement filter cartridge is not available. Some models do not come equipped with the filter bypass plug. To obtain a free bypass plug, visit us on-line at [cafeappliances.com/service](http://cafeappliances.com/service). In Canada, visit [cafeappliances.ca/service](http://cafeappliances.ca/service). The dispenser and icemaker will not operate without either the filter or the bypass plug installed. The bypass plug is installed in the same way as a filter cartridge.

### ⚠ WARNING

To reduce the risk associated with choking, do not allow children under 3 years of age to have access to small parts during the installation of this product. The disposable filter cartridge should be replaced every 6 months at the rated capacity, or sooner if a noticeable reduction in flow rate occurs.

For the maximum benefit of your filtration system, GE Appliances, a Haier company, recommends the use of GE Appliances-branded filters only. Using GE Appliances-branded filters in Café refrigerators provides optimal performance and reliability. Our filters meet rigorous industry NSF standards for safety and quality that are important for products that are filtering your water. There is no assurance that brands other than GE Appliances filters meet our standards for quality, performance and reliability.

If you have questions, or to order additional filter cartridges, visit [gewaterfilters.com](http://gewaterfilters.com). In Canada, visit [cafeappliances.ca/service](http://cafeappliances.ca/service) or consult the yellow pages for the nearest Camco Service Center.

## Installing the Filter in a Bottom Freezer Refrigerator

1. Open the filter cartridge housing by squeezing the 2 front tabs and gently pulling down.

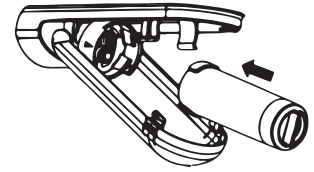

2. Line up the ports on the filter with the ports on the filter cartridge holder, and gently insert the filter.

3. Slowly turn the filter to the right until it stops. DO NOT OVERTIGHTEN. As you turn the filter, it will automatically adjust itself into position. The filter will move about a ¼ turn or 90 degrees, until the arrow on the filter aligns with the arrow on the filter cartridge holder.

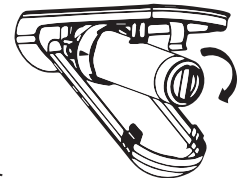

4. Slowly push the filter up into the clips.
5. Close the filter cartridge housing by gently pushing the lid upwards until the tabs lock into place.

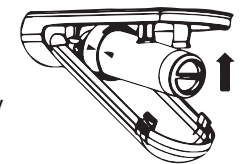

6. Run water from the dispenser for 2 gallons (7.6 liters) or approximately 5 minutes to clear the system. Water may spurt out and air bubbles may be visible during this process. If water is not flowing, check to make sure the filter has been fully rotated to the right.
7. Press and hold the WATER FILTER pad (only on select models) on the dispenser for three seconds.

## Application Guidelines/Water Supply

|                   |                            |
|-------------------|----------------------------|
| Service Flow      | 0.5 gpm (1.89 lpm)         |
| Water Supply      | Potable Water              |
| Water Pressure    | 25-120 psi (172-827 kPa)   |
| Water Temperature | 33°F-100°F (0.6°C-38°C)    |
| Capacity          | 170 gallons (643.5 liters) |

Sign-up for TEXT REMINDERS by texting REPLACE to 70543.

# Shelves and Bins

Not all features are on all models.

## Rearranging the Refrigerator Shelves

Shelves in the refrigerator compartment are adjustable.

### To remove the shelves:

1. Remove all items from the shelf.
2. Tilt the shelf up at the front.
3. Lift the shelf up at the back and bring the shelf out.

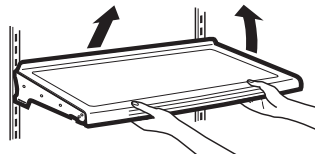

### To replace the shelves:

1. While tilting the shelf up, insert the top hook at the back of the shelf in a slot on the track.
2. Lower the front of the shelf until the bottom of the shelf locks into place.

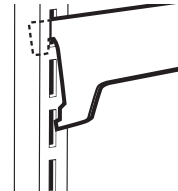

## Quick Space Shelf (on some models)

This shelf splits in half and slides under itself for storage of tall items on the shelf below.

This shelf can be removed and replaced or relocated.

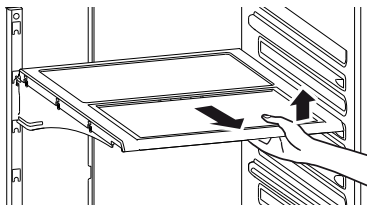

**NOTE:** The back half of the Quick Space Shelf is not adjustable.

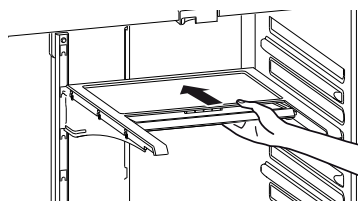

## Adjustable Door Bins (on some models)

**To remove:** Lift the bin straight up; then pull out.

**To replace:** Engage the bin in the molded supports on the door and push down to lock in place.

The door bins have bin mats that captures spills, keep containers from shifting when the door is opened, and are easily removable for cleaning.

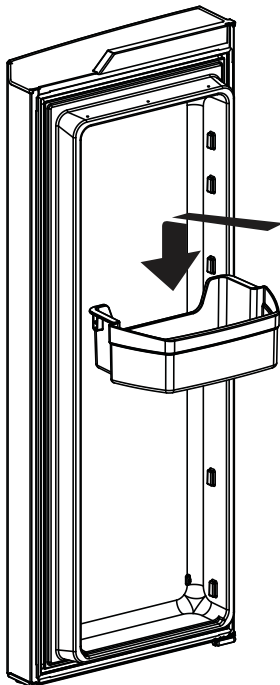

# Pans

Not all features are on all models.

## Climate Zone Pans

Keep fruits and vegetables organized in separate compartments for easy access. Excess water that may accumulate in the bottom of the drawers or under the drawers should be wiped dry.

### To remove pan:

Slide the pan out to the stop position, lift the pan up and past the stop position and pull forward.

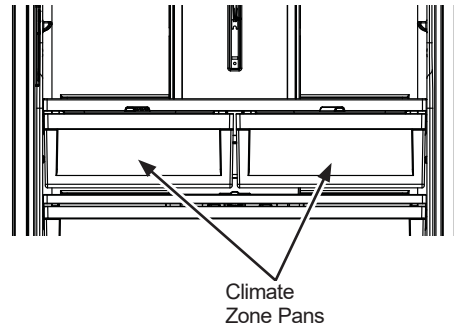

## Full -Width Pan (on some models)

### To remove pan:

1. Pull the pan out to the stop position.
2. Lift the front of the drawer up and out.

### To replace pan:

1. Place back of the drawer in first and rotate drawer front down to seat it on the slides.
2. Push the drawer in to the closed position.

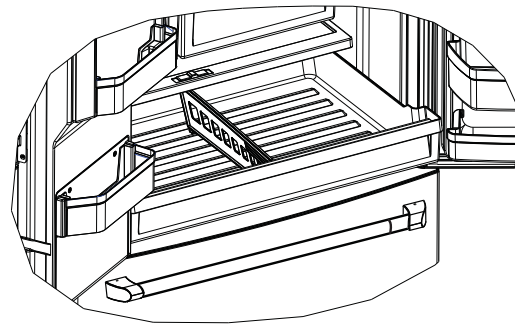

## How to Remove and Replace Drawer Divider

### To remove:

1. Pull the drawer out to the stop position.
2. Slide pan divider to right to release it from pan.

### To replace:

Reverse steps 1 and 2 to replace drawer divider.

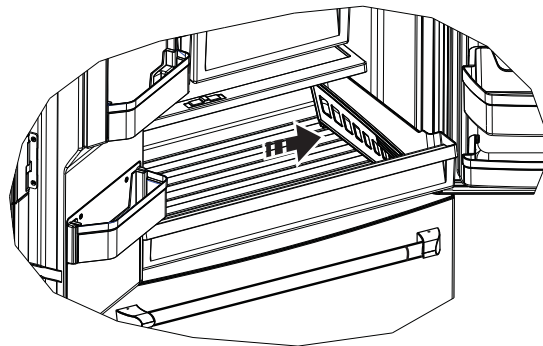

## Freezer Drawer (on some models)

Not all features are on all models.

### FREEZER BASKETS

1. An ice bucket in the top basket (on some models).
2. A top full-width basket.
3. A bottom full-width basket (with divider - in some models).

**NOTE:** Do not fill baskets higher than the rim of the basket. This may cause baskets to stick or jam when opening or closing.

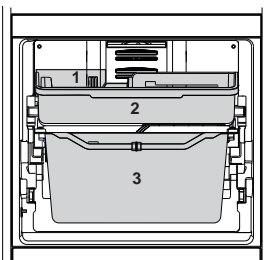

Appearance and features may vary

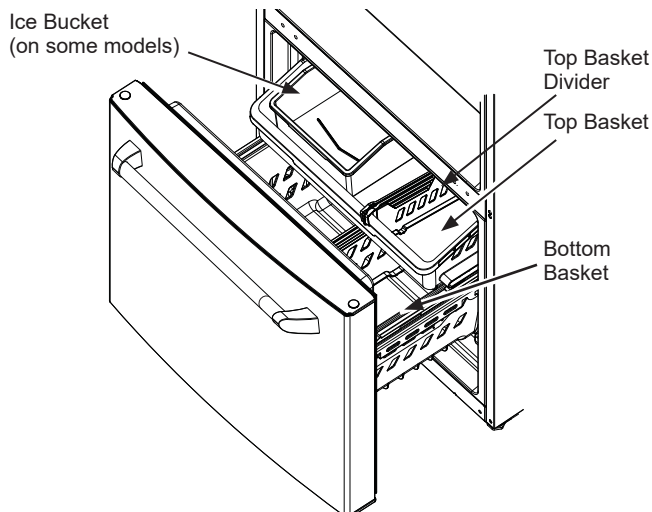

### Top Basket Removal

To remove the top full-width basket on freezer drawer models:

1. Pull the basket out to the stop location.
2. Lift basket up to release it from the slides.

**When replacing the basket,** make sure that the basket remains mounted on the side rails and over the slides of the bottom basket.

**NOTE:** Always be sure to fully close this basket.

LED lights are located on both sides of the freezer

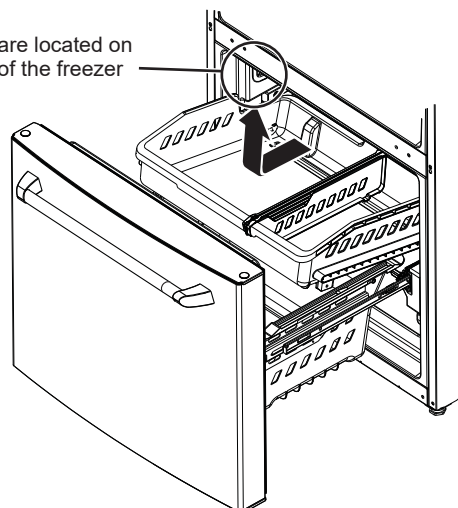

### Bottom Basket Removal

To remove the bottom full-width basket on freezer drawer models:

1. Open the bottom freezer drawer until it stops.
2. Remove the top freezer basket.
3. The bottom freezer basket rests on the inside tabs on the drawer slides.
4. Lift the front of the basket and pull forward.
5. Release the pin from the slot to remove the basket.

**When replacing the bottom full-width basket,** tilt the basket back and lower it into the drawer. Rotate the basket to a horizontal position and press down. Make sure to place the pin back into the slot.

**NOTE:** Always be sure that the basket is seated on the bracket tabs before sliding the drawer back into the freezer.

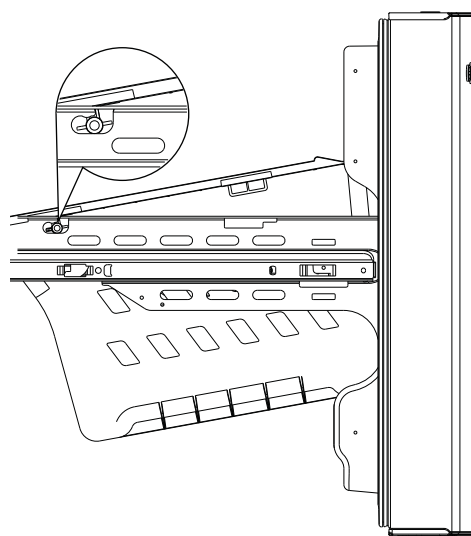

# Automatic Icemaker

A newly installed refrigerator may take 12 to 24 hours to begin making ice.

## Automatic Icemaker (on some models)

The icemaker will produce seven cubes per cycle approximately 100–130 cubes in a 24-hour period, depending on freezer compartment temperature, room temperature, number of door openings and other use conditions.

If the refrigerator is operated before the water connection is made to the icemaker, set the power switch in the **OFF** position.

When the refrigerator has been connected to the water supply, set the power switch to the **ON** position.

The icemaker will fill with water when it cools to 15°F (–10°C). A newly installed refrigerator may take 12 to 24 hours to begin making ice cubes.

You may hear a buzzing sound each time the icemaker fills with water.

Throw away the first few batches of ice to allow the water line to clear.

Be sure nothing interferes with the sweep of the feeler arm.

When the bin fills to the level of the feeler arm, the icemaker will stop producing ice. It is normal for several cubes to be joined together.

If ice is not used frequently, old ice cubes will become cloudy, taste stale and shrink.

**NOTE:** In homes with lower-than-average water pressure, you may hear the icemaker cycle multiple times when making one batch of ice.

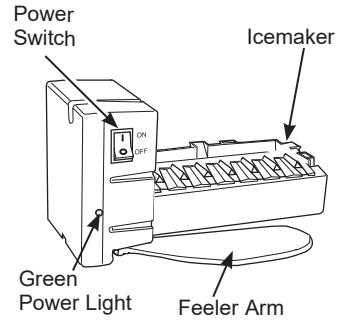

### ⚠ CAUTION

To minimize the risk of personal injury, avoid contact with the moving parts of the ejector mechanism, or with the heating element that releases the cubes. Do not place fingers or hands on the automatic ice making mechanism while the refrigerator is plugged in.

## For Refrigerator Models with Icemaker in the Door Ice Bucket and Dispenser

- Open the ice box door on inside of the left door.
- Pull up and out on the ice bucket in the left hand door to remove it from the compartment.
- To replace the ice bucket, set it on the guide brackets and push until the ice bucket seats properly.
- If bucket cannot be replaced, rotate the ice bucket fork 1/4 turn clockwise.
- Icemaker can be turned on and off using this display (see Controls on pages 6 and 7.)

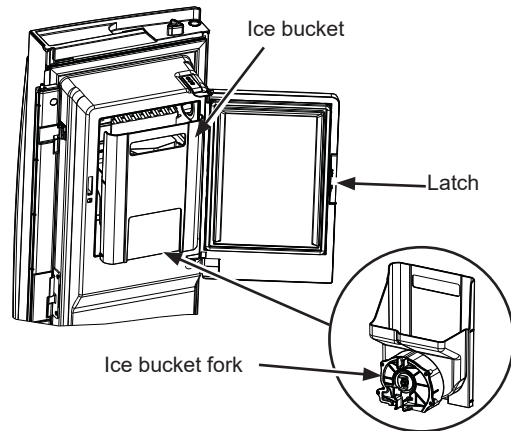

## For Refrigerator Models with Icemaker in the Freezer Compartment

Some models come with an icemaker installed in the freezer compartment. For those models that come ice-maker ready, you can purchase Kit IM4D. Visit our website at [cafeappliances.com](http://cafeappliances.com).

There is ice storage in the freezer compartment located on the left side of the upper basket. Pull the upper basket forward to remove the ice bucket.

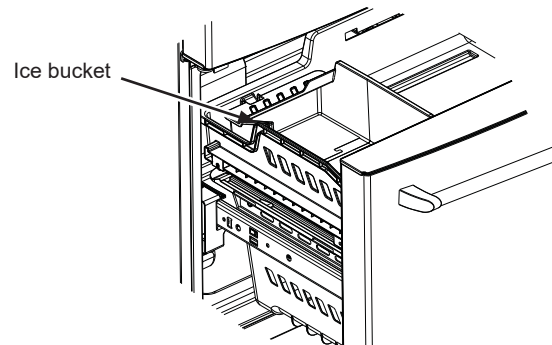

# Care and Cleaning

## Cleaning the Outside

### Directions for Cleaning Outside Surfaces, Door Handles, and Trim

| DO USE  | DO NOT USE   |
|---|--|
| Soft, clean cloth or sponge   | Abrasive cloths, scrubbing sponges, scouring or steel wool pads  |
| Mild detergent mixed with warm water<br>Approved stainless steel cleaners; Visit the Café Appliances parts store for approved stainless steel cleaners: <a href="http://cafeappliances.com/parts">cafeappliances.com/parts</a><br><br>Cleaners with oxalic acid such as Bar Keepers Friend Soft Cleanser™ can be used to remove surface rust, tarnish and small blemishes on stainless steel surfaces only. | Abrasive powders or sprays<br>Window Sprays or Ammonia<br>Citrus or plant oil-based cleaners<br>Acidic or vinegar-based cleaners<br>Oven cleaners<br>Cleaners containing acetone (propanone)<br>Any cleaner with WARNING about plastic contact |

**NOTE: DO NOT** allow stainless steel cleaner to come in contact with any plastic parts such as trim pieces, handle hardware and liners. If unintentional contact of cleaners with plastic parts does occur, clean plastic part with a sponge and mild detergent mixed with warm water.

## Cleaning the Inside

### Unplug the refrigerator before cleaning.

If this is not practical, wring excess moisture out of sponge or cloth when cleaning around switches, lights or controls.

Use an appliance wax polish on the inside surface between the doors.

Use warm water and baking soda solution—about a tablespoon (15 ml) of baking soda to a quart (1 liter) of water. This both cleans and neutralizes odors. Rinse and wipe dry.

### **CAUTION**

Do not clean glass shelves or covers with warm water when they are cold. Glass shelves and covers may break if exposed to sudden temperature changes or impact such as bumping or dropping. Tempered glass is designed to shatter into many small pieces if it breaks.

## Behind the Refrigerator

Be careful when moving the refrigerator away from the wall. All types of floor coverings can be damaged, particularly cushioned coverings and those with embossed surfaces.

Raise the leveling legs located at the bottom front of the refrigerator.

Pull the refrigerator straight out and return it to position by pushing it straight in. Moving the refrigerator in a side direction may result in damage to the floor covering or refrigerator.

Lower the leveling legs until they touch the floor.

**When pushing the refrigerator back, make sure you don't roll over the power cord or water supply line.**



# Care and Cleaning

## Preparing for Vacation

For long vacations or absences, remove food and unplug the refrigerator. Clean the interior with a baking soda solution of one tablespoon (15 ml) of baking soda to one quart (1 liter) of water. Leave the doors open.

If the temperature can drop below freezing, have a qualified service technician drain the water supply system to prevent serious property damage due to flooding.

1) Turn refrigerator off (pages 6 and 7) or unplug the refrigerator.

- 2) Empty ice bucket
- 3) Turn water supply off

**If you cut the water supply off, turn off the icemaker (pg. 13).**

Upon returning from vacation:

- 1) Replace the water filter.
- 2) Run 2 gallons of water through the cold water dispenser (about 5 minutes) to flush the system.

## Preparing to Move

Secure all loose items such as shelves and drawers by taping them securely in place to prevent damage.

When using a hand truck to move the refrigerator, do not rest the front or back of the refrigerator against the hand truck. This could damage the refrigerator.

Handle only from the sides of the refrigerator.

Be sure the refrigerator stays in an upright position during moving.

## Replacing the Lights

There is LED lighting in the fresh food compartment at the top center and on the left and right sides above the climate zone pans on the french door models. LED lighting is located at the top of the fresh food compartment on the single door models.

LED lights are also located at the top of the left and right sides of the freezer in all models.

An authorized technician will need to replace the LED light.

If this assembly needs to be replaced, schedule service on-line at [cafeappliances.com/service](http://cafeappliances.com/service).

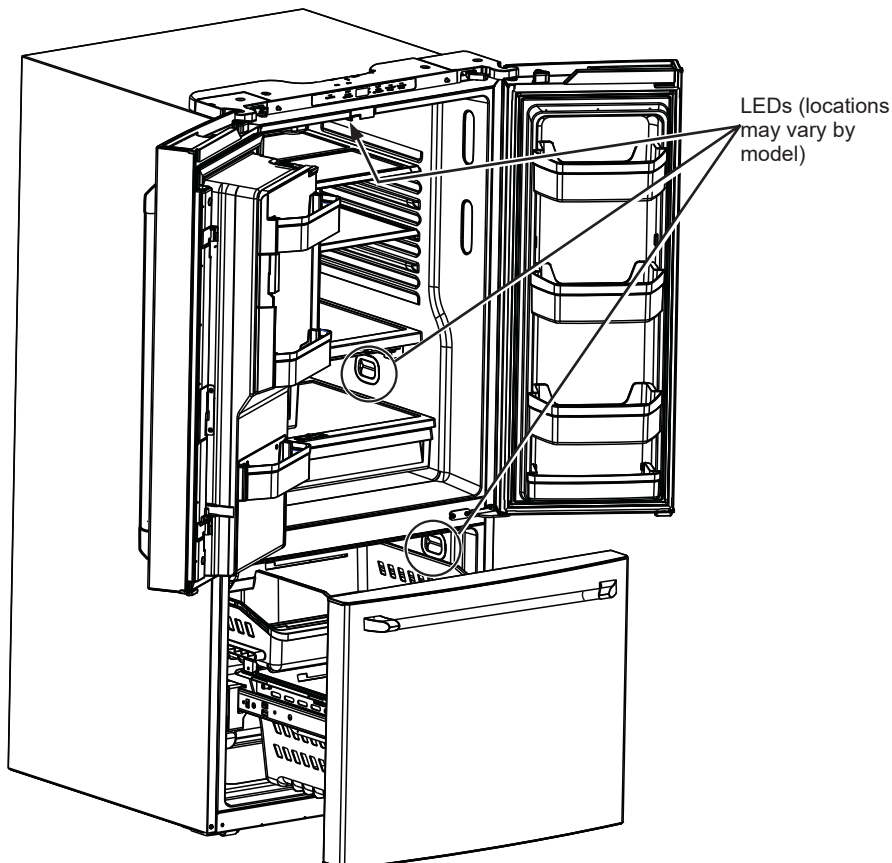



# Installation Instructions

# Refrigerator

Questions? Visit our Website at: [cafeappliances.com](http://cafeappliances.com)  
 In Canada, visit [cafeappliances.ca](http://cafeappliances.ca)

## BEFORE YOU BEGIN

Read these instructions completely and carefully.

- **IMPORTANT** — Observe all governing codes and ordinances. Save these instructions for local inspector's use.
- **Note to Installer** – Be sure to leave these instructions with the Consumer.
- **Note to Consumer** – Keep these instructions for future reference.
- **Skill level** – Installation of this appliance requires basic mechanical skills.
- **Completion time** – Refrigerator Installation  
20 minutes  
Water Line Installation  
30 minutes
- Proper installation is the responsibility of the installer.
- Product failure due to improper installation is not covered under the Warranty.

## PREPARATION

### MOVING THE REFRIGERATOR INDOORS

If the refrigerator will not fit through a doorway, the refrigerator door and freezer drawer or door can be removed.

- To remove the refrigerator doors, see Removing French Doors section.
- To remove the freezer drawer, see the Removing the Freezer Drawer section.

### WATER SUPPLY TO THE ICEMAKER AND DISPENSER

If the refrigerator has an icemaker, it will have to be connected to a cold water line. A Café water supply kit (containing tubing, shutoff valve, fittings and instructions) is available at extra cost from your dealer, or by visiting our website at [cafeappliances.com/parts](http://cafeappliances.com/parts). In Canada, visit [cafeappliances.ca/parts](http://cafeappliances.ca/parts).

## TOOLS YOU MAY NEED



Adjustable Wrench

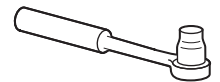

3/8" and 5/8" Socket Ratchet/Driver

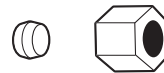

1/4" Outer Diameter Compression Nut and Ferrule (sleeve) (icemaker models only)

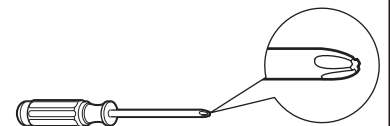

Phillips-Head Screwdriver



3/32", 1/8" & 3/16" Allen Wrenches

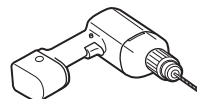

1/8" Drill Bit and Electric or Hand Drill

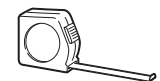

Tape Measure



Pencil



1/4" Nut Driver



Wire Cutters



Level

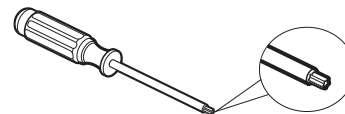

Torx T20, Driver

# Installation Instructions

## APPLIANCE DIMENSIONS

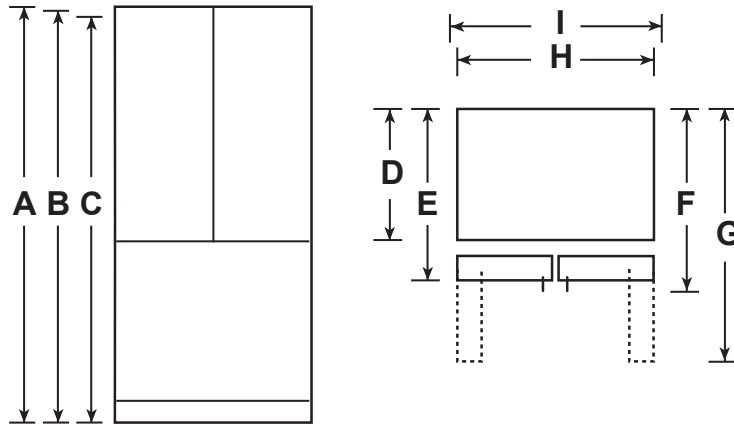

|                    |  | CWE19S | CFE26K   |
|--------------------|--|--------|----------|
| OVERALL DIMENSIONS | Height to top of door (in.) A                    | 69-7/8 | 69-7/8   |
|                    | Height to top of hinge (in.) B                   | 69-3/4 | 69-3/4   |
|                    | Height to top of case (in.) C                    | 68-5/8 | 68-5/8   |
|                    | Case depth without door (in.) D                  | 24-1/8 | 29-1/2   |
|                    | Case depth less door handle (in.) E              | 29     | 33-7/8   |
|                    | Case depth with door handle (in.) F              | 31-1/8 | 36-7/16  |
|                    | Depth with fresh food door pen 90° (in.) G       | 42     | 48-3/4   |
|                    | Width (in.) H                                    | 32-3/4 | 35-5/8   |
|                    | Width with door open 90 inc. door handle (in.) I | 41     | 43-13/16 |

### MEASURE THE CABINET OPENING ACCORDING TO THE WIDTH OF THE REFRIGERATOR

Measure width of cabinet opening where refrigerator will be placed, B. Be sure to account for any countertop overhang, baseboard thickness and any clearance desired. Width, B, should not be less than 33"-36" (83.3 cm - 91.4 cm) (depending on model). The refrigerator will be placed approximately in the middle of this opening.

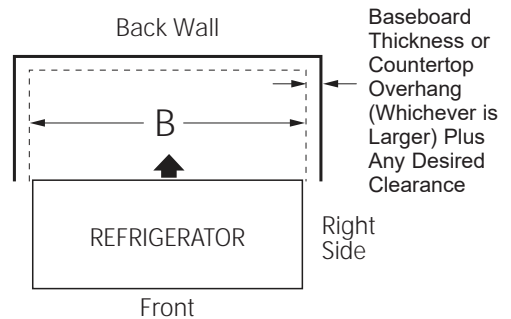

# Installation Instructions

## INSTALLING THE REFRIGERATOR

### REFRIGERATOR LOCATION

- Do not install the refrigerator where the temperature will go below 60°F (16°C) because it will not run often enough to maintain proper temperatures.
- Do not install the refrigerator where the temperature will go above 100°F (37°C) because it will not perform properly.
- Do not install the refrigerator in a location exposed to water (rain, etc.) or direct sunlight.
- Install it on a floor strong enough to support it fully loaded.

### CLEARANCES

Allow the following clearances for ease of installation, proper air circulation and plumbing and electrical connections.

|       |             |                     |
|-------|-------------|---------------------|
| Sides | 1/8" (3 mm) |                     |
| Top   | 1" (25 mm)  | Cabinet/Hinge Cover |
| Back  | 2" (50 mm)  |                     |

### IMPORTANT NOTES

This refrigerator without the handles ranges from 33-7/8" to 35-1/4" (86 cm - 89 cm) depending on your model (see dimension E on the previous page). Doors and passageways leading to the installation location must be at least 36" (91.4 cm) in order to leave the doors attached to the refrigerator while transporting it into the installation location. If passageways are less than 36" (91.4 cm), the refrigerator doors can easily be scratched and damaged. The doors can be removed to allow the refrigerator to be safely moved indoors.

- If you need to remove the door, see Removing French Doors.
- To remove the freezer door, see Removing Freezer Drawer.
- If it is **NOT** necessary to remove doors, leave tape and all packaging on doors until the refrigerator is in the final location. Once in place, install door handles (see Steps 1 and 2).
- **SKID REMOVAL:** Tilt refrigerator to each side to remove skid.
- **NOTE:** Use a padded hand truck to move this refrigerator. Place the refrigerator on the hand truck with a side against the truck. We strongly recommend that **TWO PEOPLE** move and complete this installation.

### 1 ATTACH FRESH FOOD HANDLES

1. Loosen the set screws in the handle with the 1/8" Allen wrench.
2. Place handle over mounting fasteners.
3. Tighten set screws.

Follow the same procedure for both doors.

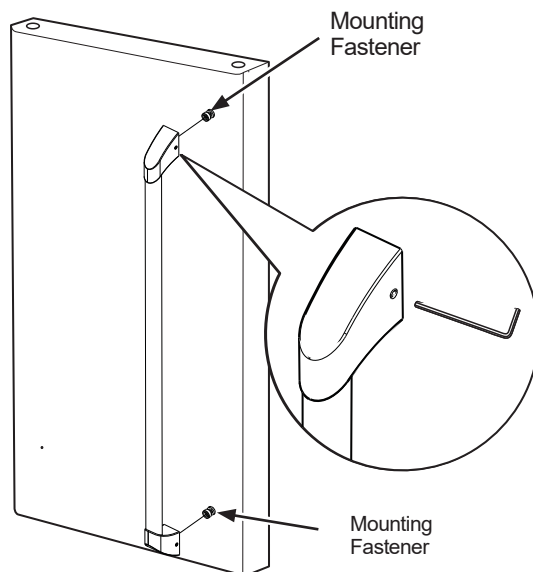

### 2 ATTACH FREEZER HANDLE

1. Loosen the set screws in the handle with the 1/8" Allen wrench.
2. Place handle over mounting fasteners.
3. Tighten set screws.

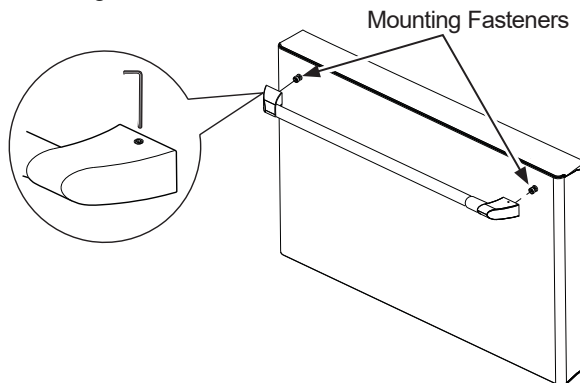

# Installation Instructions

## INSTALLING THE REFRIGERATOR (Cont.)

### REMOVING FRENCH DOORS

#### IMPORTANT NOTES

When removing french doors:

- Read the instructions all the way through before starting.
- Handles are included inside the refrigerator.
- Place the screws by their related parts to avoid using them in the wrong places.
- Provide a non-scratching work surface for the doors.

#### **CAUTION** Lifting Hazard.

Single person lift can cause injury. Use assistance when handling, moving or lifting the refrigerator doors.

**NOTE:** When moving door, to prevent damage to door and electronics carefully place the door in a proper location.

#### **WARNING**

To eliminate the risk of electric shock or injury during installation, you must first unplug the refrigerator before proceeding. Failure to follow these instructions can result in electrical shock.

Tape the doors shut with adhesive tape.

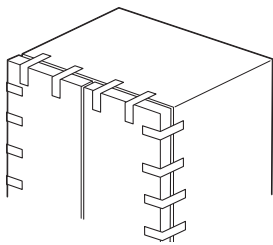

#### 1 REMOVING RIGHT DOOR

- A. Remove the hinge cover on top of the right fresh food door by removing the screw using a Phillips screwdriver.

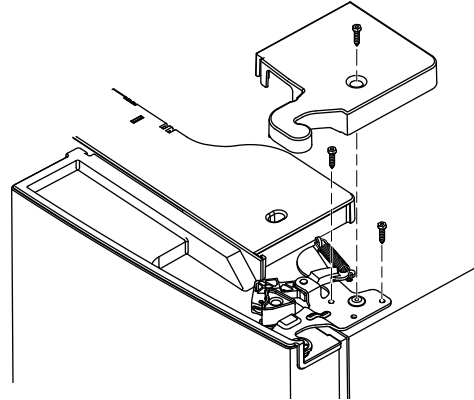

- B. Using a 5/16" socket ratchet/driver, remove the bolts securing the top hinge to the cabinet. Lift the hinge support straight up to free the hinge pin from the socket in the top of the door.
- C. Remove the tape from the right door and tilt the door away from the cabinet. Lift the door off the center hinge pin.
- D. Set the door on a non-scratching surface with the inside up.

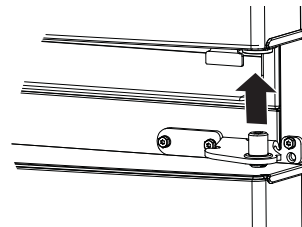

#### 2 REMOVING LEFT DOOR

- A. **For Ice and Water Models Only:** Unplug the water line from the back of the refrigerator and remove all tape that fixes the water line to the refrigerator.

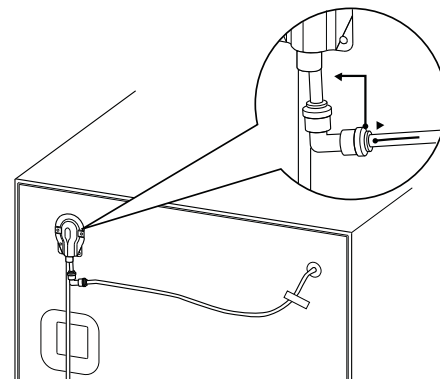

# Installation Instructions

## INSTALLING THE REFRIGERATOR (Cont.)

### 2 REMOVING LEFT DOOR (cont.)

**B.** Remove the hinge cover on top of the left fresh food door by removing the screw using a Phillips screwdriver.

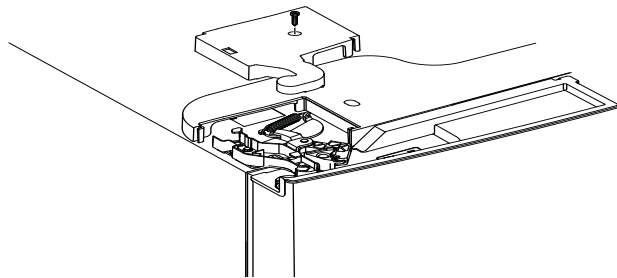

**C.** Unplug the 3 wire connectors and move the wires until you can see the screws holding the hinge.

**For Ice and Water Models Only:** Pull the water line very carefully.

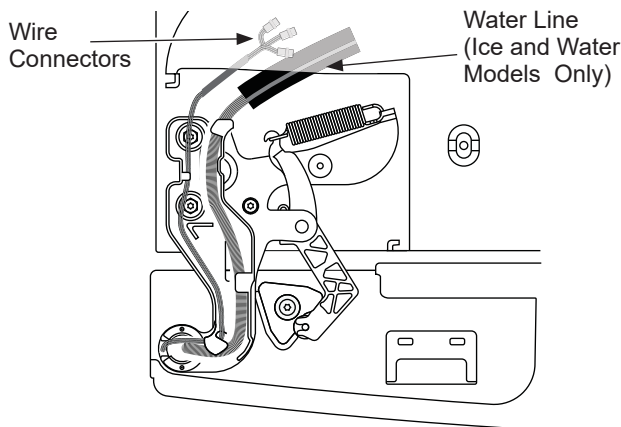

**D.** Using a 5/16" socket/ratchet driver, remove the bolts securing the top hinge to the cabinet.

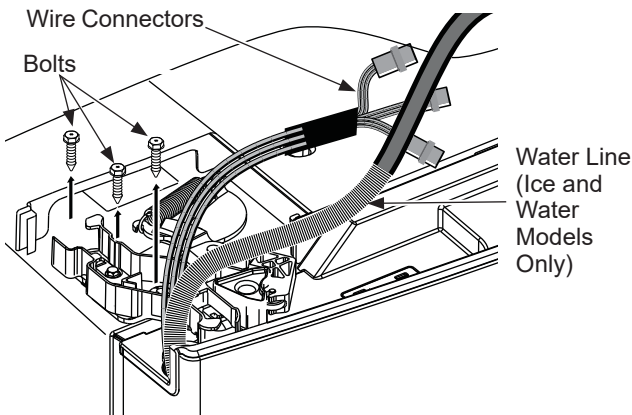

**For NON Ice and Water Models Only:** Lift the hinge straight up to free the hinge pin from the socket in the top of the door and pass the wire through the slot in the hinge. **For Ice and Water Models Only:** Do not remove hinge from the door.

**E.** Remove the tape from the door, open the door 90 degrees and tilt the door away from the cabinet. Lift the door off the center hinge pin.

**F.** Set the door on a non-scratching surface with the inside up.

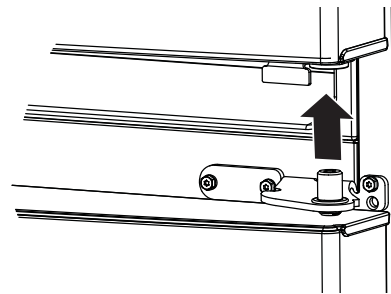

### 3 REMOVING CENTER HINGES AND BRACKETS

**A.** Using a 1/4" Allen wrench, remove the 2 hinge pins from the hinge brackets.

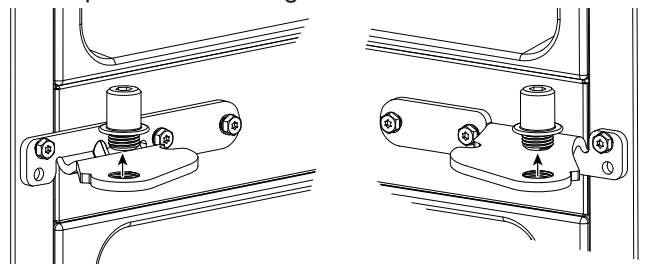

**B.** Using a 5/16" socket/ratchet driver, remove the bolts securing the center hinge brackets to the cabinet.

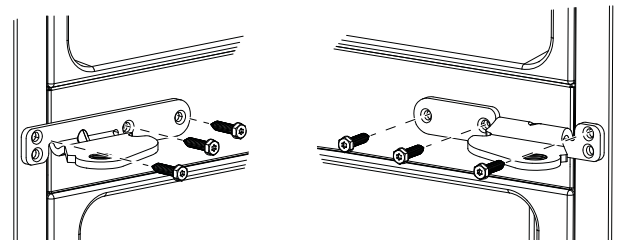

# Installation Instructions

## INSTALLING THE REFRIGERATOR (Cont.)

### REINSTALLING FRENCH DOORS

#### IMPORTANT NOTES

When replacing the french doors:

- Read the instructions all the way through before starting.

#### **CAUTION** Lifting Hazard.

Single person lift can cause injury. Use assistance when handling, moving or lifting the refrigerator doors.

**NOTE:** When moving door, to prevent damage to door and electronics carefully place the door in a proper location.

#### **WARNING**

To eliminate the risk of electric shock or injury during installation, you must first unplug the refrigerator before proceeding. Failure to follow these instructions can result in electrical shock.

#### 1 REINSTALLING CENTER HINGE BRACKETS AND HINGES

- A. Using a 5/16" socket/ratchet driver, reinstall the bolts and center hinge brackets to the cabinet.

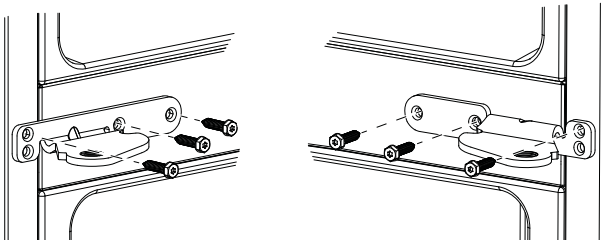

- B. Using a 1/4" Allen wrench, reinstall the 2 hinge pins into the hinge brackets.

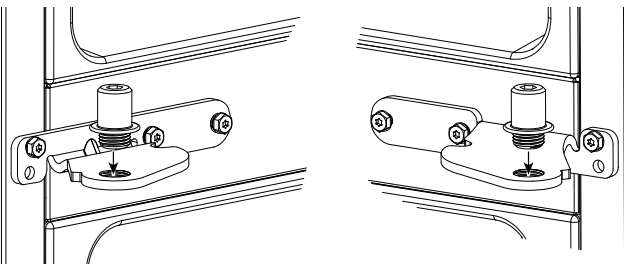

#### 2 REHANGING THE RIGHT DOOR

- A. Lower the refrigerator door onto the right hinge pin.

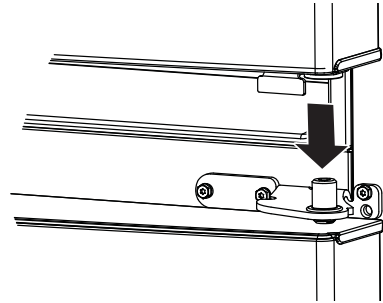

- B. Make sure the door is aligned with the cabinet. Attach the hinge to the top of the cabinet loosely with bolts removed earlier.
- C. Make sure the gasket on the door is flush against the cabinet and is not folded. Tighten the bolts to 60 lb/in. (6.78 Nm).

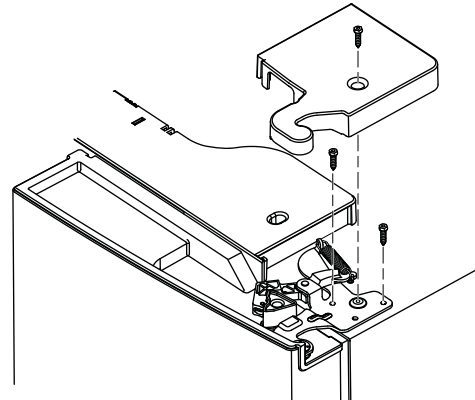

- D. Replace the right hinge cover on top of the refrigerator using a Phillips screwdriver.

#### 3 REHANGING THE LEFT DOOR

- A. **For NON Ice and Water Models Only:** Pass the wire through the slot in the hinge. Place the hinge pin into the top of the door.
- B. Lower the refrigerator door onto the left hinge pin.

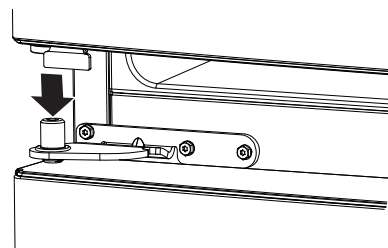

# Installation Instructions

## INSTALLING THE REFRIGERATOR (Cont.)

### REINSTALLING FRENCH DOORS (Cont.)

#### ③ REHANGING THE LEFT DOOR (Cont.)

- C. Make sure the door is aligned with the cabinet. Attach the hinge to the top of the cabinet loosely with bolts removed earlier.
- D. Make sure the gasket on the door is flush against the cabinet and is not folded. Tighten the bolts to 60 lb/in. (6.78 Nm).

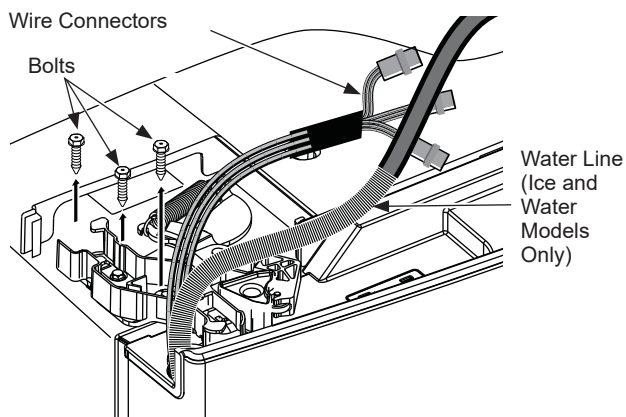

- E. Plug the wire connectors together and route the wire inside the plastic port.

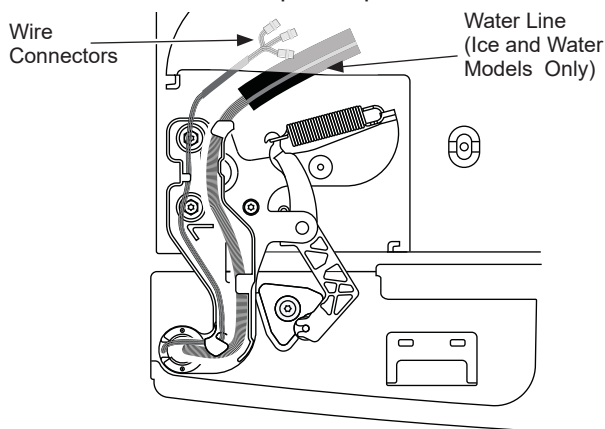

- F. **For Ice and Water Models Only:** Put the water line into the hole and pass through the plastic port to the back of the refrigerator. Plug the water line back into the fixture on back of the refrigerator. Tape water line to the refrigerator.

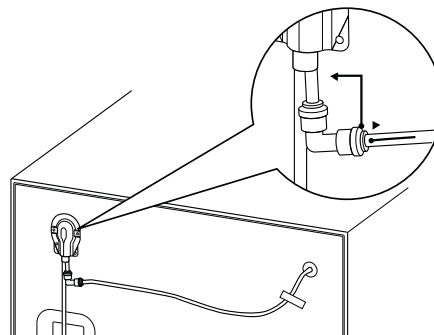

- G. Replace the left hinge cover on top of the refrigerator using a Phillips screwdriver.

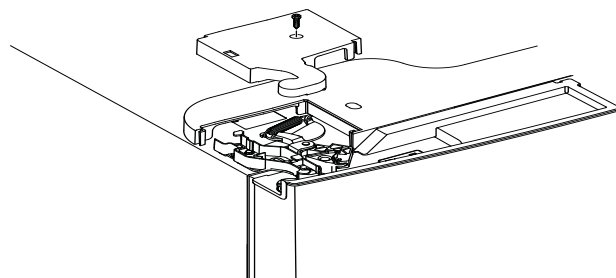



# Installation Instructions

## INSTALLING THE REFRIGERATOR (Cont.)

### REMOVING FREEZER DRAWER

#### IMPORTANT NOTES

When removing freezer drawer:

- Read the instructions all the way through before starting.
- Provide a non-scratching work surface for the doors.

#### 1 REMOVE THE BASKETS

- Open the freezer drawer until it stops.
- Pull the top basket out until it stops. Lift the basket up on the front and out to remove.

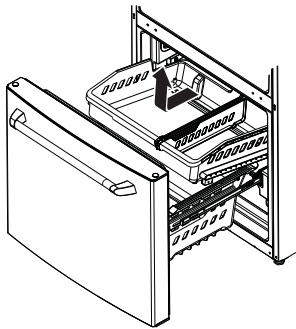

- The lower basket rests on a frame inside the freezer drawer. Lift the front of the basket and pull it forward. Release the pins from the slots on the frame to remove the basket.

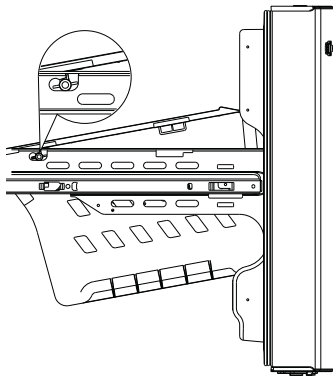

#### 2 REMOVE THE DRAWER FRONT

- Remove the screw on each side of the railing.

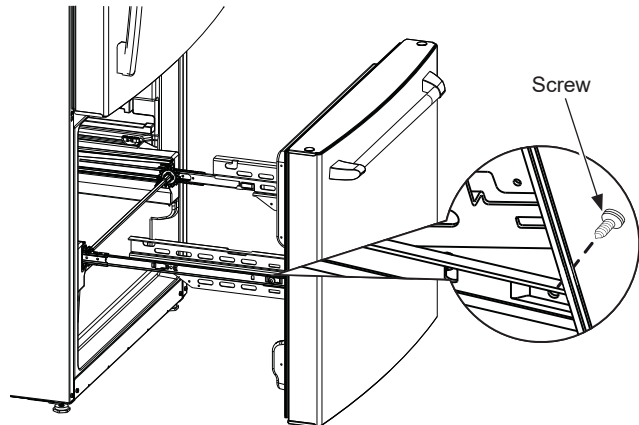

- Lift up on both sides of the freezer drawer handle to separate the drawer railings from the rail assemblies.

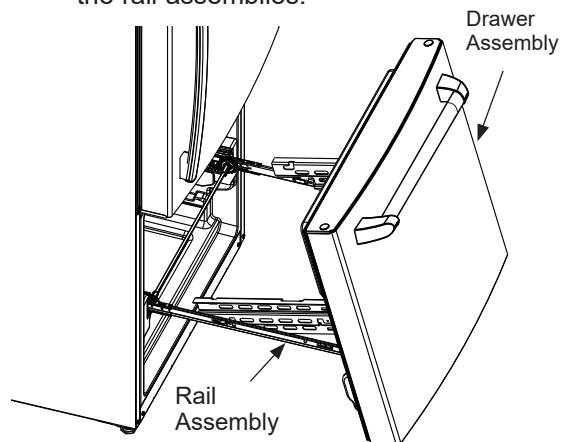

- Set the drawer front on a non-scratching surface.
- Push the rail assemblies back into locking position.

# Installation Instructions

## INSTALLING THE REFRIGERATOR (Cont.)

### 3 REINSTALL FREEZER DRAWER FRONT

- A. Pull the rail assemblies to the maximum extension.
- B. Locate the slots on the inside of each slide.

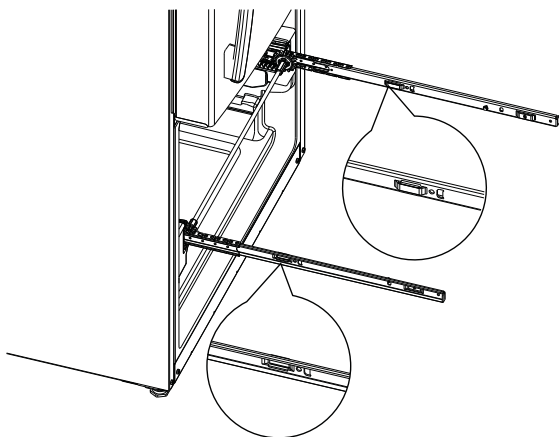

- D. Lower the front end of the freezer drawer assembly so the side tabs fit into the front slots on the rail assemblies.
- E. Replace the safety screws in both sides of the slide assemblies.

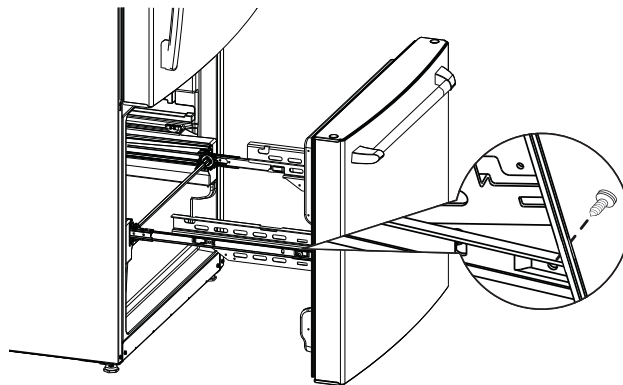

- C. Insert the hooks on the ends of the drawer assembly extensions into the slots near the back of the slides.

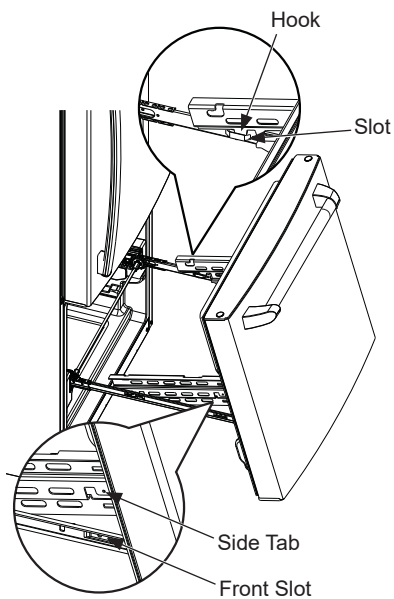

- F. Replace lower and upper baskets (see About freezer drawer, page 12).

# Installation Instructions

## INSTALLING THE REFRIGERATOR (Cont.)

### CONNECTING TO THE HOUSE WATER LINE

#### (Icemaker models only)

A cold water supply is required for automatic icemaker operation. If there is not a cold water supply, you will need to provide one. See Installing the Water Line section.

#### NOTES:

- Before making the connection to the refrigerator, be sure the refrigerator power cord is not plugged into the wall outlet.
- If your refrigerator does not have a water filter, we recommend installing one if your water supply has sand or particles that could clog the screen of the refrigerator's water valve. Install it in the water line near the refrigerator. If using Universal Water Line Refrigerator Tubing Kit, you will need an additional tube (WX08X10002) to connect the filter. Do not cut plastic tube to install filter.
- Before connecting the water line to the house, purge the house line for at least 2 minutes.

**A. If you are using copper tubing**, place a compression nut and ferrule (sleeve) onto the end of the tubing coming from the house cold water supply.

**If you are using the Universal tubing**, the nuts are already assembled to the tubing.

**B. If you are using copper tubing**, insert the end of the tubing into the refrigerator connection, at the back of the refrigerator, as far as possible. While holding the tubing, tighten the fitting.

If you are using Universal tubing, insert the molded end of the tubing into the refrigerator connection, at the back of the refrigerator, and tighten the compression nut until it is hand tight. Then tighten one additional turn with a wrench. Over tightening may cause leaks.

**C.** Fasten the tubing into the clamp provided to hold it in position. You may need to pry open the clamp.

One of the illustrations below will look like the connection on your refrigerator.

#### **⚠ WARNING**

Connect to potable water supply only.

A cold water supply is required for automatic icemaker operation. The water pressure must be between 40 and 120 psi (275-827 kilopascals).

#### **⚠ WARNING**



#### **ELECTRIC SHOCK HAZARD**

Attach tubing clamp using existing hole only. **DO NOT** drill into the refrigerator.

#### Icemaker-Ready Models

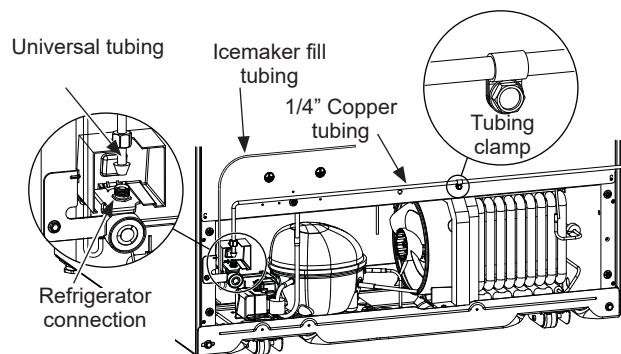

#### Icemaker-Installed Models

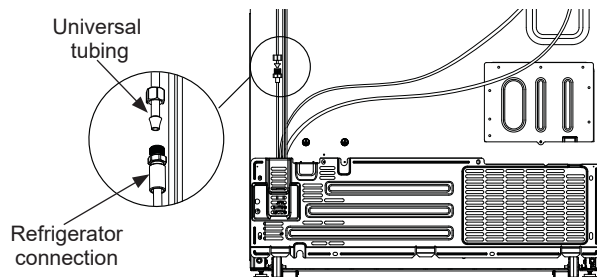

# Installation Instructions

## INSTALLING THE REFRIGERATOR (Cont.)

### TURN ON THE WATER SUPPLY

(Icemaker models only)

Turn the water on at the shutoff valve (house water supply) and check for any leaks.

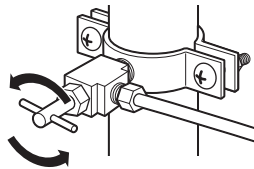

### PLUG IN THE REFRIGERATOR

On models with an icemaker, before plugging in the refrigerator, make sure the icemaker power switch is set to the 0 (off) position.

See the grounding information attached to the power cord.

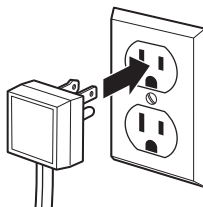

### PUT THE REFRIGERATOR IN PLACE

Move the refrigerator to its final location.

### LEVEL THE REFRIGERATOR

**Adjustable legs** at the front corners of the refrigerator should be set so the refrigerator is firmly positioned on the floor, and the front is raised just enough that the door closes easily when opened about halfway.

**To adjust the leveling legs**, turn the legs **clockwise to raise** the refrigerator, **counterclockwise to lower** it.

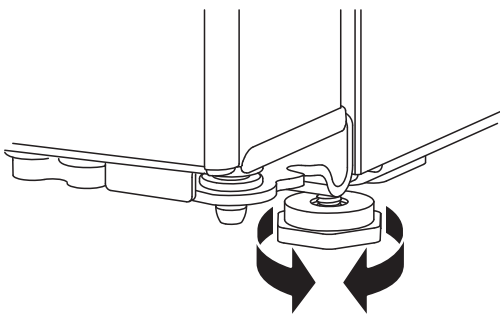

### LEVEL THE REFRIGERATOR DOORS (on some models)

Remember a level refrigerator is necessary for getting the doors perfectly even. If you need help, review the previous section on leveling the refrigerator.

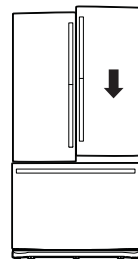

When the left door is lower than the right door.

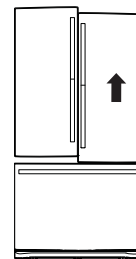

When the left door is higher than the right door.

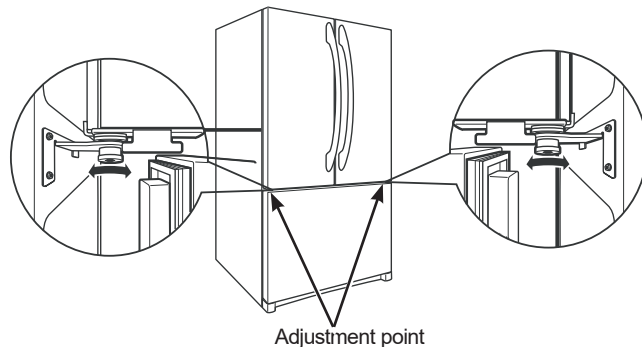

If the doors remain uneven, turn the adjustable pin to raise the lowest door using a 1/4" allen wrench to turn the pin.

# Installation Instructions

## Refrigerator suggested assembly

Shelves shown in the location for best energy efficiency.

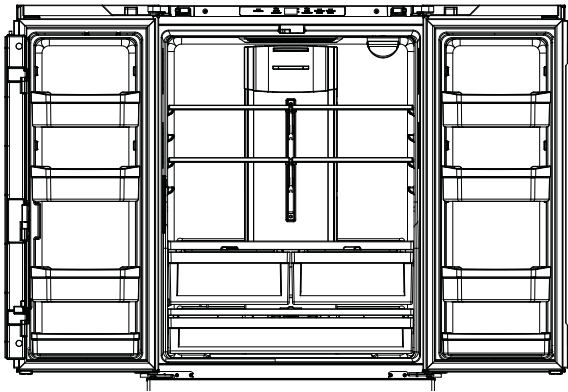

**CWE19S 19 cuft. Models**  
French Door with Freezer Drawer

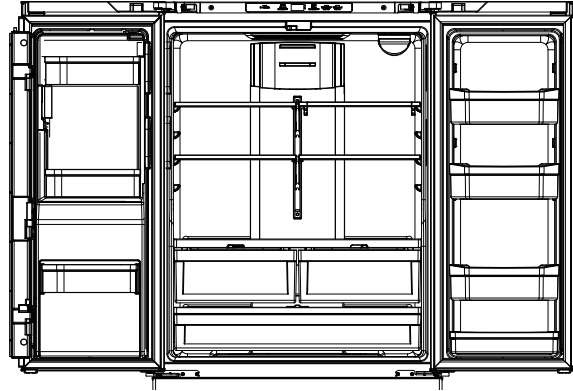

**CFE26K 26 cuft. Models**  
French Door with Freezer Drawer

**NOTE:** Do not block air outlet by placing food items directly against it. Erratic temperatures may result.

# Installation Instructions

## INSTALLING THE WATER LINE

### BEFORE YOU BEGIN

If the water supply to the refrigerator is from a Reverse Osmosis Water Filtration System (RO) AND the refrigerator also has a water filter, use the refrigerator's filter bypass plug. Using the refrigerator's water filtration cartridge in conjunction with an RO water filter can result in hollow ice cubes. Some models do not come equipped with the filter bypass plug. To obtain a free bypass plug, visit [cafeappliances.com/service](http://cafeappliances.com/service). In Canada, visit [cafeappliances.ca/service](http://cafeappliances.ca/service).

This water line installation is not warranted by the refrigerator or icemaker manufacturer. Follow these instructions carefully to minimize the risk of expensive water damage.

Water hammer (water banging in the pipes) in house plumbing can cause damage to refrigerator parts and lead to water leakage or flooding. Call a qualified plumber to correct water hammer before installing the water supply line to the refrigerator.

To prevent burns and product damage, do not hook up the water line to the hot water line.

Do not install the icemaker tubing in areas where temperatures fall below freezing.

When using any electrical device (such as a power drill) during installation, be sure the device is double insulated or grounded in a manner to prevent the hazard of electric shock, or is battery powered.

All installations must be in accordance with local plumbing code requirements.

### WHAT YOU WILL NEED

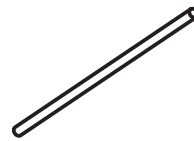

- Copper or Universal Water Line Refrigerator Tubing Kit, 1/4" outer diameter to connect the refrigerator to the water supply. If using copper, be sure both ends of the tubing are cut square.

To determine how much tubing you need: measure the distance from the water valve on the back of the refrigerator to the water supply pipe. Be sure there is sufficient extra tubing to allow the refrigerator to move out from the wall after installation.

Universal Water Line Refrigerator Tubing Kits are available in the following lengths:

6' (1.8 m) – WX08X10006

15' (4.6 m) – WX08X10015

25' (7.6 m) – WX08X10025

### ▲ WARNING

Connect to potable water supply only.

A cold water supply is required for automatic icemaker operation. The water pressure must be between 40 and 120 psi (275-827 kilopascals)

# Installation Instructions

## INSTALLING THE WATER LINE (Cont.)

### WHAT YOU WILL NEED (Cont.)

**NOTE:** The only Crosley approved plastic tubing is that supplied in Universal Water Line Refrigerator Tubing Kits. Do not use any other plastic water supply line because the line is under pressure at all times. Certain types of plastic will crack or rupture with age and cause water damage to your home.

- A water supply kit (containing tubing, shutoff valve and fittings listed below) is available at extra cost from your dealer or from [cafeappliances.com/parts](http://cafeappliances.com/parts). In Canada, visit [cafeappliances.ca/parts](http://cafeappliances.ca/parts).
- A cold water supply. The water pressure must be between 20 and 120 p.s.i. (138-827 kPa).

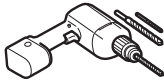

- Power drill.
- 1/2" or adjustable wrench.
- Straight and Phillips blade screwdriver.

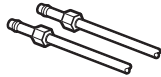

- Two 1/4" outer diameter compression nuts and 2 ferrules (sleeves)—to connect the copper tubing to the shutoff valve and the refrigerator water valve. OR
- If you are using a Universal Water Line Refrigerator Tubing Kit, the necessary fittings are preassembled to the tubing.

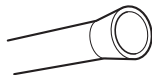

- If your existing copper water line has a flared fitting at the end, you will need an adapter (available at plumbing supply stores) to connect the water line to the refrigerator OR you can cut off the flared fitting with a tube cutter and then use a compression fitting. Do not cut formed end from Universal Water Line Refrigerator tubing.

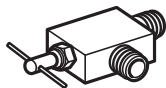

- Shutoff valve to connect to the cold water line. The shutoff valve should have a water inlet with a minimum inside diameter of 5/32" at the point of connection to the COLD WATER LINE. Saddle-type shutoff valves are included in many water supply kits. Before purchasing, make sure a saddle-type valve complies with your local plumbing codes.

Install the shutoff valve on the nearest frequently used drinking water line.

### 1 SHUT OFF THE MAIN WATER SUPPLY

Turn on the nearest faucet long enough to clear the line of water.

### 2 CHOOSE THE VALVE LOCATION

Choose a location for the valve that is easily accessible. It is best to connect into the side of a vertical water pipe. When it is necessary to connect into a horizontal water pipe, make the connection to the top or side, rather than at the bottom, to avoid drawing off any sediment from the water pipe.



### 3 DRILL THE HOLE FOR THE VALVE

Drill a 1/4" hole in the water pipe (even if using a self-piercing valve), using a sharp bit. Remove any burrs resulting from drilling the hole in the pipe.

Take care not to allow water to drain into the drill.

Failure to drill a 1/4" hole may result in reduced ice production or smaller cubes.

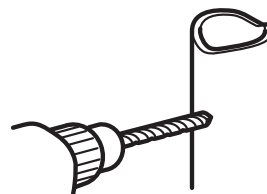



# Installation Instructions

## INSTALLING THE WATER LINE (Cont.)

### 4 FASTEN THE SHUTOFF VALVE

Fasten the shutoff valve to the cold water pipe with the pipe clamp.

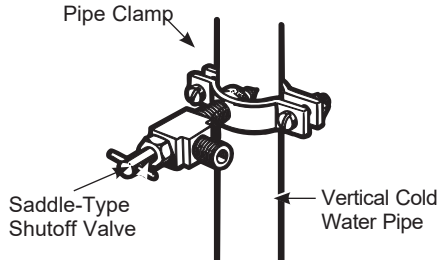

**NOTE:** Commonwealth of Massachusetts Plumbing Codes 248CMR shall be adhered to. Saddle valves are illegal and use is not permitted in Massachusetts. Consult with your licensed plumber.

### 5 TIGHTEN THE PIPE CLAMP

Tighten the clamp screws until the sealing washer begins to swell.

**NOTE:** Do not over tighten or you may crush the tubing.

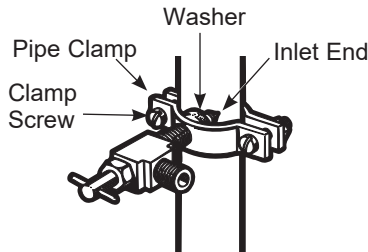

### 6 ROUTE THE TUBING

Route the tubing between the cold water line and the refrigerator.

Route the tubing through a hole drilled in the wall or floor (behind the refrigerator or adjacent base cabinet) as close to the wall as possible.

### 7 FASTEN THE SHUTOFF VALVE

Place the compression nut and ferrule (sleeve) for copper tubing onto the end of the tubing and connect it to the shutoff valve.

Make sure the tubing is fully inserted into the valve. Tighten the compression nut securely.

For plastic tubing from a Universal Water Line Refrigerator Tubing Kit, insert the molded end of the tubing into the shutoff valve and tighten compression nut until it is hand tight, then tighten one additional turn with a wrench. Over tightening may cause leaks.

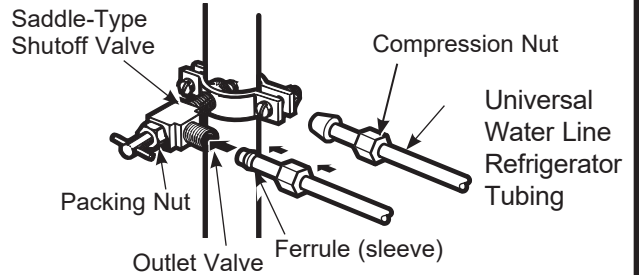

**NOTE:** Commonwealth of Massachusetts Plumbing Codes 248CMR shall be adhered to. Saddle valves are illegal and use is not permitted in Massachusetts. Consult with your licensed plumber.

### 8 FLUSH OUT THE TUBING

Turn the main water supply on and flush out the tubing until the water is clear.

Shut the water off at the water valve after about one quart (1 liter), or 2 minutes, of water has been flushed through the tubing.



# Normal Operating Conditions.

Newer refrigerators sound different from older refrigerators.  
Modern refrigerators have more features and use newer technology.

## Do you hear what I hear? These conditions are normal.

**HUMMM...**



**WHOOSH...**

- The new high efficiency compressor may run faster and longer than your old refrigerator and you may hear a high-pitched hum or pulsating sound while it is operating.
- You may hear a whooshing sound when the doors close. This is due to pressure equalizing within the refrigerator.



- You may hear the fans spinning at high speeds. This happens when the refrigerator is first plugged in, when the doors are opened frequently or when a large amount of food is added to the refrigerator or freezer compartments. The fans are helping to maintain the correct temperatures.
- The fans change speeds in order to provide optimal cooling and energy savings.

## CLICKS, POPS, CRACKS and SNAPS

- You may hear cracking or popping sounds when the refrigerator is first plugged in. This happens as the refrigerator cools to the correct temperature.
- Expansion and contraction of cooling coils during and after defrost can cause a cracking or popping sound.
- On models with an icemaker, after an ice making cycle, you may hear the ice cubes dropping into the ice bucket.
- On models with a dispenser, during water dispense, you may hear the water lines move at initial dispense and after dispenser button is released.

## WATER SOUNDS



- The flow of refrigerant through the cooling coils may make a gurgling noise like boiling water.
- Water dropping on the defrost heater can cause a sizzling, popping or buzzing sound during the defrost cycle.
- A water dripping noise may occur during the defrost cycle as ice melts from the evaporator and flows into the drain pan.
- Closing the door may cause a gurgling sound due to pressure equalization.

## Troubleshooting Tips... Before you call for service

Save time and money! Review the charts on the following pages first and you may not need to call for service.

| <b>Problem</b>   | <b>Possible Causes</b>   | <b>What to Do</b>  |
|--|--|--|
| Refrigerator does not operate  | Refrigerator in defrost cycle.   | Wait about 30 minutes for defrost cycle to end.                                    |
|  | Either or both controls set to OFF.  | Set the controls to a lower temperature setting.                                   |
|  | Refrigerator is unplugged.   | Push the plug completely into the outlet.  |
|  | The fuse is blown/circuit breaker is tripped.  | Replace fuse or reset the breaker.   |
|  | Refrigerator is in showroom mode.  | Unplug the refrigerator and plug it back in.                                       |
| Vibration or rattling (slight vibration is normal)   | Leveling legs need adjusting.  | See Level the refrigerator.  |
| Motor operates for long periods or cycles on and off frequently. (Modern refrigerators with more storage space and a larger freezer require more operating time. They start and stop often to maintain even temperatures.) | Normal when refrigerator is first plugged in.  | Wait 24 hours for the refrigerator to completely cool down.                        |
|  | Often occurs when large amounts of food are placed in refrigerator.                            | This is normal.  |
|  | Door left open.  | Check to see if package is holding door open.                                      |
|  | Hot weather or frequent door openings.   | This is normal.  |
|  | Temperature controls set at the coldest setting.   | See Controls section   |
| Refrigerator or freezer compartment too warm   | Temperature control not set cold enough.   | See Controls section   |
|  | Warm weather or frequent door openings.  | Set the temperature control one step colder. See Controls section                  |
|  | Door left open.  | Check to see if package is holding door open.                                      |
| Frost or ice crystals on frozen food (frost within package is normal)  | Door left open.  | Check to see if package is holding door open.                                      |
|  | Too frequent or too long door openings.  | This is normal.  |
| Divider between refrigerator and freezer compartments feels warm   | Automatic energy saver system circulates warm liquid around front edge of freezer compartment. | This helps prevent condensation on the outside.                                    |
| Automatic icemaker does not work   | Icemaker power switch is in the OFF position.  | Set the power switch to the ON position.   |
|  | Water supply turned off or not connected.  | See Installing the Water Line section  |
|  | Freezer compartment too warm.  | Wait 24 hours for the refrigerator to completely cool down.                        |
|  | Piled up cubes in the storage bin cause the icemaker to shut off.                              | Level cubes by hand.   |
|  | Ice cubes stuck in icemaker.   | Turn off the icemaker, remove cubes, and turn the icemaker back on.                |
| Freezer cooling, fresh food not cooling  | Normal, when refrigerator first plugged in or after extended power outage                      | Wait 24 hours for temperature in both compartments to reach selected temperatures. |
| Ice dispenser opens after closing freezer drawer   | Normal   | The ice dispenser door may open after closing freezer door to allow access.        |

# Troubleshooting Tips... Before you call for service

| Problem   | Possible Causes  | What to Do  |
|---|--|---|
| Ice cubes have odor/taste   | Ice storage bin needs cleaning.  | Empty and wash bin. Discard old cubes.  |
|   | Food transmitting odor/taste to ice cubes.   | Wrap foods well.  |
|   | Interior of refrigerator needs cleaning.   | See Care and Cleaning section.  |
| Small or hollow cubes   | Water filter clogged.  | Replace filter cartridge with new cartridge or with plug.   |
| Slow ice cube freezing  | Door left open.  | Check to see if package is holding door open.   |
|   | Temperature control not set cold enough.   | See Controls section  |
| Frequent 'buzzing sound"  | Icemaker power switch is in the I (on) position, but the water supply to the refrigerator has not been connected.                                | Set the power switch to the 0 (off) position. Keeping it in the I (on) position will damage the water valve.                            |
| Orange glow in the freezer  | Defrost heater is on.  | This is normal.   |
| Water has poor taste/odor   | Water dispenser has not been used for a long time.   | Dispense water until all water in system is replenished.  |
| Water in first glass is warm  | Normal when refrigerator is first installed.   | Wait 24 hours for the refrigerator to completely cool down.   |
|   | Water dispenser has not been used for a long time.   | Dispense water until all water in system is replenished.  |
|   | Water system has been drained.   | Allow several hours for replenished supply to chill.  |
| Water dispenser does not work   | Water supply line turned off or not connected.   | See Installing the water line section   |
|   | Water filter clogged.  | Replace filter cartridge or remove filter and install plug.   |
|   | Air may be trapped in the water system.  | Press the dispenser arm for at least two minutes.   |
|   | Dispenser is LOCKED.   | Press and hold the LOCK pad for 3 seconds.  |
| Water spurting from dispenser   | Newly-installed filter cartridge.  | Run water from the dispenser for 3 minutes (about one and a half gallons).  |
| Water is not dispensed but icemaker is working  | Water in reservoir is frozen.  | Call for service.   |
|   | Refrigerator control setting is too cold.  | Set to a warmer setting.  |
| No water or ice cube production   | Supply line or shutoff valve is clogged.   | Call a plumber.   |
|   | Water filter clogged.  | Replace filter cartridge or remove filter and install plug.   |
| Refrigerator has odor   | Foods transmitting odor to refrigerator.   | Foods with strong odors should be tightly wrapped. Keep an open box of baking soda in the refrigerator; replace every three months.     |
|   | Interior needs cleaning.   | See Care and Cleaning section   |
| Moisture forms on outside of refrigerator   | Not unusual during periods of high humidity.   | Wipe surface dry.   |
| Moisture collects inside (in humid weather, air carries moisture into refrigerator when doors are opened) | Too frequent or too long door openings.  | This is normal.   |
|   | Due to the higher humidity in the refrigerator, you may on occasion experience fog or small amounts of moisture in the refrigerator compartment. | This is normal and may come and go as different food loads and environmental conditions change. Wipe dry with a paper towel if desired. |
| Interior light does not work  | No power at outlet.  | Replace fuse or reset the breaker.  |
|   | LED lights are out   | Call Service - see Replacing the Lights   |

# TROUBLESHOOTING TIPS Troubleshooting Tips... Before you call for service

Save time and money! Review the charts on the following pages first and you may not need to call for service.

## TROUBLESHOOTING TIPS

| Problem  | Possible Causes   | What to Do  |
|--|---|---|
| Hot air from bottom of refrigerator  | Normal air flow cooling motor. In the refrigeration process, it is normal that heat be expelled in the area under the refrigerator. Some floor coverings are sensitive and will discolor at these normal and safe temperatures. | This is normal.   |
| Refrigerator never shuts off but the temperatures are OK                       | Adaptive defrost keeps compressor running during door openings.   | This is normal. The refrigerator will cycle off after the door remains closed for 2 hours.  |
| Refrigerator is beeping  | Door is open.   | Close door.   |
| Door not closing properly  | Door gasket on hinge side sticking or folding over.   | Apply paraffin wax to the face of the gasket.   |
| Actual temperature not equal to Set temperature                                | Unit just plugged in.   | Allow 24 hours for system to stabilize.   |
|  | Door open for too long.   | Allow 24 hours for system to stabilize.   |
|  | Warm food added to refrigerator.  | Allow 24 hours for system to stabilize.   |
|  | Defrost cycle is in process.  | Allow 24 hours for system to stabilize.   |
| Door/drawer does not close by itself   | Leveling legs need adjusting.   | See Level the refrigerator  |
| Freezer drawer pops open when refrigerator door is closed                      | This is normal if, after popping open, the freezer drawer closed on its own.  | This indicates that there is a good seal on the freezer drawer. If the freezer drawer does not automatically close after popping open, then see the <b>Problem:</b> Door/ drawer does not close by itself, above.   |
| Food freezing in the refrigerator  | Food too close to the air vent at the back of the refrigerator.   | Move the food away from the air vent.   |
|  | Refrigerator control is set too cold.   | Move the refrigerator control to a warmer temperature setting one increment at a time.  |
| Water is leaking from dispenser  | Glass not being held under the dispenser long enough after button is released.  | Hold the glass underneath the dispenser for 2–3 seconds after releasing the dispenser button. Water may continue to dispense after the button is released   |
|  | Air may be present in the water line system, causing water to drip after being dispensed.   | Dispense water for at least 2 minutes to remove air from system.  |
| My display is showing <b>tc</b>  | Turbo Cool function is activated.   | See Controls section  |
| Water filter indicator light changed color                                     | This is normal.   | See Water Filter Cartridge - XWF section  |
| Water filter indicator light remains red even after replacing the water filter | Water filter indicator must be reset.   | Press and hold the WATER FILTER pad for 3 seconds. See Water Filter Cartridge - XWF section.  |
| Water filter indicator light is not lit  | This is normal. The filter cartridge should be replaced when the replacement indicator light turns red.   | See Water Filter Cartridge - XWF section  |
| Handle is loose / handle has a gap   | Handle needs adjusting.   | See Attach the Fresh Food Handle and Attach the Freezer Handle sections   |
| Refrigerator doors are not even  | Doors need realigning.  | See Level the Refrigerator Doors section.   |
| Baskets stick or jam when opening or closing                                   | Baskets are too full.   | <b>To open:</b> remove some of the products from the basket when opened as far as possible. Readjust the products left in the basket and try to open the basket again. <b>To close:</b> readjust products in the basket or remove any product that is above the rim of the basket and close the basket. |

# Café Refrigerator Limited Warranty

**LIMITED WARRANTY**

## cafeappliances.com

All warranty service is provided by our Factory Service Centers, or an authorized service technician. To schedule service online, visit us at [cafeappliances.com/service](http://cafeappliances.com/service). Please have your serial number and your model number available when scheduling service. In Canada, visit [cafeappliances.ca/service](http://cafeappliances.ca/service).

Servicing your refrigerator may require the use of the onboard data port for diagnostics. This gives a Café Factory Service technician the ability to quickly diagnose any issues with your appliance and helps Café improve its products by providing Café with information on your appliance. If you do not want your appliance data to be sent to Café, please advise your technician NOT to submit the data to Café at the time of service.

| For the Period of:   | Café Will Replace   |
|--|---|
| <b>One Year</b><br>From the date of the original purchase  | <b>Any part</b> of the refrigerator which fails due to a defect in materials or workmanship. During the <b>limited one-year warranty</b> , Café will also provide, <b>free of charge</b> , all labor and related service to replace the defective part.   |
| <b>Thirty Days</b><br>(Water filter, if included)<br>From the original purchase date of the refrigerator | <b>Any part</b> of the water filter cartridge which fails due to a defect in materials or workmanship. During this <b>limited thirty-day warranty</b> , Café will also provide, <b>free of charge</b> , a replacement water filter cartridge.   |
| <b>Five Years</b><br>From the date of the purchase   | <b>Any part</b> of the sealed refrigerating system (the compressor, condenser, evaporator and all connecting tubing) which fails due to a defect in materials or workmanship. During this <b>limited five-year sealed refrigerating system warranty</b> , Café will also provide, <b>free of charge</b> , all labor and related service to replace the defective part in the sealed refrigerating system. |

### What Café Will Not Cover:

- Service trips to your home to teach you how to use the product.
- Improper installation, delivery or maintenance.
- Failure of the product if it is abused, misused, or used for other than the intended purpose or used commercially.
- Loss of food due to spoilage.
- Replacement of house fuses or resetting of circuit breakers.
- Damage to finish, such as surface rust, tarnish, or small blemishes not reported within 48 hours of delivery.
- Replacement of the water filter cartridge, if included, due to water pressure that is outside the specified operating range or due to excessive sediment in the water supply.
- Replacement of the light bulbs, if included, or water filter cartridge, if included, other than as noted above.
- Damage to the product caused by accident, fire, floods or acts of God.
- Incidental or consequential damage caused by possible defects with this appliance.
- Product not accessible to provide required service.
- Damage caused by a non-GE Appliances Brand water filter.

**EXCLUSION OF IMPLIED WARRANTIES**  
Your sole and exclusive remedy is product repair as provided in this Limited Warranty. Any implied warranties, including the implied warranties of merchantability or fitness for a particular purpose, are limited to one year or the shortest period allowed by law.

**For US Customers:** This limited warranty is extended to the original purchaser and any succeeding owner for products purchased for home use within the USA. If the product is located in an area where service by a Café Authorized Servicer is not available, you may be responsible for a trip charge or you may be required to bring the product to an Authorized Café Service location for service. In Alaska, the limited warranty excludes the cost of shipping or service calls to your home.

Some states do not allow the exclusion or limitation of incidental or consequential damages. This limited warranty gives you specific legal rights, and you may also have other rights which vary from state to state. To know what your legal rights are, consult your local or state consumer affairs office or your state's Attorney General.

**Warrantor: GE Appliances, a Haier company**  
**Louisville, KY 40225**

**For Customers in Canada:** This limited warranty is extended to the original purchaser and any succeeding owner for products purchased in Canada for home use within Canada. In-home warrant service will be provided in areas where it is available and deemed reasonable by Mabe to provide.

**Warrantor Canada: MC Commercial, Inc., Burlington, Ontario, L7R 5B6**

Staple your receipt here. Proof of the original purchase date is needed to obtain service under the warranty.







# Performance Data Sheet

## Model: XWF

- System certified by IAPMO R&T against NSF/ANSI Standards 42, 53, 401 for the reduction of claims specified on the performance data sheet and at [iapmort.org](http://iapmort.org).
- Actual performance may vary with local water conditions.

| Substance Tested for Reduction      | Influent challenge concentration (mg/L) | Maximum permissible product water concentration (mg/L) | Avg % Reduction |
|-------------------------------------|---|--|-----------------|
| Chlorine Taste and Odor             | 2.0 mg/L +/- 10%                        | N/A  | 96.9            |
| Chloramine Taste and Odor           | 3.0 mg/L +/- 10%                        | 0.5  | 96.9            |
| Particulate, Class I                | At least 10,000/mL                      | N/A  | 91.4            |
| Cysts                               | 50,000/L                                | N/A  | >99.99          |
| Lead                                | 0.15                                    | 0.01   | 98.85           |
| Mercury                             | 0.006                                   | 0.002  | 96.3            |
| Asbestos                            | 107 to 108 fibers/ L                    | N/A  | >99             |
| Toxaphene                           | 0.015 +/- 10%                           | 0.003  | 86.95           |
| VOC (Chloroform surrogate chemical) | 0.300                                   | 0.015  | 99.7            |
| Alachlor                            | 0.050                                   | 0.001  | > 98            |
| Atrazine                            | 0.100                                   | 0.003  | > 97            |
| Benzene                             | 0.081                                   | 0.001  | > 99            |
| Carbofuran                          | 0.190                                   | 0.001  | > 99            |
| carbon tetrachloride                | 0.078                                   | 0.0018   | 98              |
| chlorobenzene                       | 0.077                                   | 0.001  | > 99            |
| chloropicrin                        | 0.015                                   | 0.0002   | 99              |
| 2,4-D                               | 0.110                                   | 0.0017   | 98              |
| dibromochloropropane (DBCP)         | 0.052                                   | 0.00002  | > 99            |
| o-Dichlorobenzene                   | 0.08                                    | 0.001  | > 99            |
| p-Dichlorobenzene                   | 0.040                                   | 0.001  | > 98            |
| 1,2-dichloroethane                  | 0.088                                   | 0.0048   | 95              |
| 1,1-dichloroethylene                | 0.083                                   | 0.001  | > 99            |
| cis-1,2-dichloroethylene            | 0.170                                   | 0.0005   | > 99            |
| trans-1,2-dichloroethylene          | 0.086                                   | 0.001  | > 99            |
| 1,2-dichloropropane                 | 0.080                                   | 0.001  | > 99            |
| cis-1,3-dichloropropylene           | 0.079                                   | 0.001  | > 99            |
| dinoseb                             | 0.170                                   | 0.0002   | 99              |
| Endrin                              | 0.053                                   | 0.00059  | 99              |
| Ethylbenzene                        | 0.088                                   | 0.001  | > 99            |
| ethylene dibromide (EDB)            | 0.044                                   | 0.00002  | > 99            |
| bromochloroacetonitrile             | 0.022                                   | 0.0005   | 98              |
| dibromoacetonitrile                 | 0.024                                   | 0.0006   | 98              |
| dichloroacetonitrile                | 0.0096                                  | 0.0002   | 98              |
| trichloroacetonitrile               | 0.015                                   | 0.0003   | 98              |
| 1,1-dichloro-2-propanone            | 0.0072                                  | 0.0001   | 99              |
| 1,1,1-trichloro-2-propanone         | 0.0082                                  | 0.0003   | 96              |
| heptachlor (H-34, Heptox)           | 0.025                                   | 0.00001  | >99             |
| heptachlor epoxide                  | 0.0107                                  | 0.0002   | 98              |
| hexachlorobutadiene                 | 0.044                                   | 0.001  | > 98            |
| hexachlorocyclopentadiene           | 0.060                                   | 0.000002   | > 99            |
| Lindane                             | 0.055                                   | 0.00001  | > 99            |
| methoxychlor                        | 0.050                                   | 0.0001   | > 99            |
| pentachlorophenol                   | 0.096                                   | 0.001  | > 99            |
| simazine                            | 0.120                                   | 0.004  | > 97            |
| Styrene                             | 0.150                                   | 0.0005   | > 99            |
| 1,1,2,2-tetrachloroethane           | 0.081                                   | 0.001  | > 99            |
| Tetrachloroethylene                 | 0.081                                   | 0.001  | > 99            |
| Toluene                             | 0.078                                   | 0.001  | > 99            |
| 2,4,5-TP (silvex)                   | 0.270                                   | 0.0016   | 99              |
| tribromoacetic acid                 | 0.042                                   | 0.001  | > 98            |
| 1,2,4-Trichlorobenzene              | 0.160                                   | 0.0005   | > 99            |
| 1,1,1-trichloroethane               | 0.084                                   | 0.0046   | 95              |
| 1,1,2-trichloroethane               | 0.150                                   | 0.0005   | > 99            |
| trichloroethylene                   | 0.180                                   | 0.0010   | > 99            |
| bromoform                           | 0.300                                   | 0.015  | 95              |
| bromodichloromethane                | 0.300                                   | 0.015  | 95              |
| chlorodibromomethane                | 0.300                                   | 0.015  | 95              |
| xylene                              | 0.070                                   | 0.001  | >99             |
| Meprobamate                         | 400 +/- 20%                             | 60   | 95.5            |
| Atenolol                            | 200 +/- 20%                             | 30   | 95.9            |
| Carbamazepine                       | 1400 +/- 20%                            | 200  | 98.6            |
| DEET                                | 1400 +/- 20%                            | 200  | 98.6            |
| Metolachlor                         | 1400 +/- 20%                            | 200  | 98.7            |
| Trimethoprim                        | 140 +/- 20%                             | 20   | 96.1            |
| Linuron                             | 140 +/- 20%                             | 20   | 96.6            |
| TCEP                                | 5000 +/- 20%                            | 700  | 98.1            |
| T CPP                               | 5000 +/- 20%                            | 700  | 98.1            |
| Phenytol                            | 200 +/- 20%                             | 30   | 96              |
| Ibuprofen                           | 400 +/- 20%                             | 60   | 95.9            |
| Naproxen                            | 140 +/- 20%                             | 20   | 96.5            |
| Estrone                             | 140 +/- 20%                             | 20   | 97.1            |
| Bisphenol A                         | 2000 +/- 20%                            | 300  | 99.1            |
| Nonyl phenol                        | 1400 +/- 20%                            | 200  | 97.3            |

### Application Guidelines/Water Supply Parameters

|                   |                            |
|-------------------|----------------------------|
| Service Flow      | 0.5 gpm (1.89 lpm)         |
| Water Supply      | Potable Water              |
| Water Pressure    | 25-120 psi (172-827 kPa)   |
| Water Temperature | 33°F-100°F (0.6°C-38°C)    |
| Capacity          | 170 gallons (643.5 liters) |

It is essential that the manufacturer's recommended installation, maintenance and filter replacement requirements be carried out for the product to perform as advertised. See Installation Manual for Warranty information.

**Note:** While the testing was performed under standard laboratory conditions, actual performance may vary.

Replacement Cartridge: XWF. For estimated costs of replacement elements please visit our website at [cafeappliances.com](http://cafeappliances.com).

### ⚠ WARNING To reduce the risk associated with ingestion of contaminants:

- Do not use with water that is microbiologically unsafe or of unknown quality without adequate disinfection before and after the system. Systems certified for cyst reduction may be used on disinfected water that may contain filterable cysts.

### NOTICE

To reduce the risk of water leakage or flooding, and to ensure optimal filter performance:

- Read and follow use instructions before installation and use of this system.
- Installation and use **MUST** comply with all state and local plumbing codes.
- Do not install if water pressure exceeds 120 psi (827 kPa). If your water pressure exceeds 80 psi (552 kPa), you **must** install a pressure-limiting valve. Contact a plumbing professional if you are uncertain how to check your water pressure.
- Do not install where water hammer conditions may occur. If water hammer conditions exist you **must** install a water hammer arrester. Contact a plumbing professional if you are uncertain how to check for this condition.
- Do not install on hot water supply lines. The maximum operating water temperature of this filter system is 100° F (38° C).
- Protect filter from freezing. Drain filter when temperatures drop below 33°F (0.6°C).
- Change the disposable filter cartridge every six months or sooner if you observe a noticeable reduction in water flow rate.
- Failure to replace the disposable filter cartridge at recommended intervals may lead to reduced filter performance and cracks in the filter housing, causing water leakage or flooding.
- This System has been tested according to NSF/ANSI 42, 53 and 401 for the reduction of the substances listed below. The concentration of the indicated substances in water entering the system was reduced to a concentration less than or equal to the permissible limit for water leaving the system, as specified in NSF/ANSI 42, 53 and 401.



XWF System is certified by IAPMO R&T against NSF/ANSI Standards 42, 53, and 401 for the reduction of claims specified on the performance data sheet and at [iapmort.org](http://iapmort.org).

# Notes

---

# Notes

---

# Consumer Support

---

## Café Website

Have a question or need assistance with your appliance? Try the Café website 24 hours a day, any day of the year! You can also shop for more great Café products and take advantage of all our on-line support services designed for your convenience. In the US: [cafeappliances.com](http://cafeappliances.com)

---

## Register Your Appliance

Register your new appliance on-line at your convenience! Timely product registration will allow for enhanced communication and prompt service under the terms of your warranty, should the need arise. You may also mail in the pre-printed registration card included in the packing material. In the US: [cafeappliances.com/register](http://cafeappliances.com/register)

---

## Schedule Service

Expert Café repair service is only one step away from your door. Get on-line and schedule your service at your convenience any day of the year. In the US: [cafeappliances.com/service](http://cafeappliances.com/service)

---

## Extended Warranties

Purchase a Café extended warranty and learn about special discounts that are available while your warranty is still in effect. You can purchase it on-line anytime. Café Service will still be there after your warranty expires. In the US: [cafeappliances.com/extended-warranty](http://cafeappliances.com/extended-warranty)

---

## Remote Connectivity

For assistance with wireless network connectivity (for models with remote enable), visit our website at [cafeappliances.com/connect](http://cafeappliances.com/connect)

---

## Parts and Accessories

Individuals qualified to service their own appliances can have parts or accessories sent directly to their homes (VISA, MasterCard and Discover cards are accepted). Order on-line today 24 hours every day. In the US: [cafeappliances.com/parts](http://cafeappliances.com/parts)

**Instructions contained in this manual cover procedures to be performed by any user. Other servicing generally should be referred to qualified service personnel. Caution must be exercised, since improper servicing may cause unsafe operation.**

---

## Contact Us

If you are not satisfied with the service you receive from Café, contact us on our website with all the details including your phone number, or write to:

In the US: General Manager, Customer Relations | Café Appliances, Appliance Park | Louisville, KY 40225  
[cafeappliances.com/contact](http://cafeappliances.com/contact)