



Use and Care Guide

Electric Range



Safety instructions	3-5
Anti-Tip Device	3, 32



Operating Instructions, Tips	
Aluminum Foil	5, 16, 20, 22
Features	6, 7
Oven	14-27
Baking	15-17
Broiling, Broiling Guide	22, 23
Control, Clock and Timer	12, 13
Fan	14, 15, 17, 18, 20, 22, 25, 26
Light; Bulb Replacement	14, 31
Oven Vent.	4
Roasting, Roasting Guide	20, 21
Self-Cleaning instructions	24-27
Timed Baking	17, 18
Surface Controls	8-11
Control Settings	8, 9
Cooktop Comparison	8
Cookware Tips	10
Home Canning Tips	11



Care and Cleaning	28-31
Cooktop	29, 31
Control Panel and Knobs	28
Lift-Off Oven Door	30
Self-Cleaning Instructions	24-27
Shelves	31
Surface Units and Drip Pans	29



Problem Solver	33, 34
Thermostat Adjustment-	
Do It Yourself	19
More questions ?...call	
GE Answer Center™ 800.626.2000	



Consumer Services	35
Appliance Registration	2
Important Phone Numbers	35
Model and Serial Number Location	2
Removal of Packaging Tape	2
Warranty	Back Cover



HELP US HELP YOU...

Before using your range, read this guide carefully.

It is intended to help you operate and maintain your new range properly.

Keep it handy for answers to your questions.

If you don't understand something or need more help, write (include your phone number):

Consumer Affairs
GE Appliances
Appliance Park
Louisville, KY 40225

How to Remove Packaging Tape

To assure no damage is done to the finish of the product, the safest way to remove the packaging tape adhesive on new appliances is an application of a household liquid dishwashing detergent, mineral oil or cooking oil. Apply with a soft cloth and allow to soak. Wipe dry and then apply an appliance polish to thoroughly clean and protect the surface.

NOTE: The plastic tape must be removed from the chrome trim on range parts. It cannot be removed if it is baked on.

Write down the model and serial numbers.

You'll find them on a label behind the storage drawer.

These numbers are also on the Consumer Product Ownership Registration Card that came with your range. Before sending in this card, please write these numbers here:

Model Number

Serial Number

Use these numbers in any correspondence or service calls concerning your range.

If you received a damaged range...

Immediately contact the dealer (or builder) that sold you the range.

Save time and money. Before you request service...

Check the Problem Solver in the back of this guide. It lists causes of minor operating problems that you can correct yourself.

IF YOU NEED SERVICE...

If you need service...

To obtain service, see the Consumer Services page in the back of this guide.

We're proud of our service and want you to be pleased. If for some reason you are not happy with the service you receive, here are three steps to follow for further help.

FIRST, contact the people who serviced your appliance. Explain why you are not pleased. In most cases, this will solve the problem.

NEXT, if you are still not pleased, write all the details—including your phone number—to:

Manager, Consumer Relations
GE Appliances
Appliance Park
Louisville, KY 40225

FINALLY, if your problem is still not resolved, write:

Major Appliance Consumer Action Panel
20 North Wacker Drive
Chicago, IL 60606

IMPORTANT SAFETY INSTRUCTIONS

Read all instructions before using this appliance.



IMPORTANT SAFETY NOTICE

- **The California Safe Drinking Water and Toxic Enforcement Act** requires the Governor of California to publish a list of substances known to the state to cause cancer, birth defects or other reproductive harm, and requires businesses to warn customers of potential exposure to such substances.
- **The fiberglass insulation in self-clean ovens gives off a very small amount of carbon monoxide during the cleaning cycle.** Exposure can be minimized by venting with an open window or using a ventilation fan or hood.

When using electrical appliances, basic safety precautions should be followed, including the following:

- Use this appliance only for its intended use as described in this guide.
- **Be sure your appliance is properly installed and grounded by a qualified technician in accordance with the provided installation instructions.**
- **Do not attempt to repair or replace any part of your range unless it is specifically recommended in this guide.** All other servicing should be referred to a qualified technician.

▲ WARNING—

All ranges can tip and injury could result. To prevent accidental tipping of the range, attach it to the wall or floor by installing the Anti-Tip device supplied. Make sure the chain fits securely into the slot in the bracket.

If you pull the range out from the wall for any reason, make sure the device is properly engaged when you push the range back against the wall. If it is not, there is a possible risk of the range tipping over and causing injury if you or a child stand, sit or lean on an open door.

Please refer to the Anti-Tip device information in this guide. Failure to take this precaution could result in tipping of the range and injury.

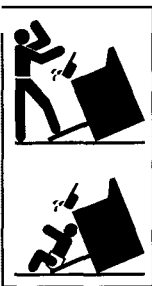

- **Before performing any service, DISCONNECT THE RANGE POWER SUPPLY AT THE HOUSEHOLD DISTRIBUTION PANEL BY REMOVING THE FUSE OR SWITCHING OFF THE CIRCUIT BREAKER.**
- **Do not leave children alone**— children should not be left alone or unattended in an area where an appliance is in use. They should never be allowed to sit or stand on any part of the appliance.
- **Do not allow anyone to climb, stand or hang on the floor, drawer or cooktop. They could damage the range and even tip it over, causing severe personal injury.**
- **Teach children not to play with the controls** or any part of the range. -
- Never leave **the oven door** open when **you** are not watching the range.
- Always keep combustible **wall coverings, curtains or drapes** a safe distance from your range.
- Always keep dishtowels, dish **cloths**, pot holders and other linens a safe distance from your range.
- * Always keep **wooden and plastic utensils and canned food** a safe distance away from your range.
- **CAUTION: ITEMS OF INTEREST TO CHILDREN SHOULD NOT BE STORED IN CABINETS ABOVE A RANGE OR ON THE BACKSPLASH OF A RANGE—CHILDREN CLIMBING ON THE RANGE TO REACH ITEMS COULD BE SERIOUSLY INJURED.**
- **Never wear loose-fitting or hanging garments while using the appliance.** Be careful when reaching for items stored in cabinets over the range. Flammable material could be ignited if brought in contact with hot surface units and heating elements and may cause severe burns.
- **Use only dry pot holders**—moist or damp pot holders on hot surfaces may result in burns from steam. Do not let pot holders touch hot surface units or heating elements. Do not use a towel or other bulky cloth. Such cloths can catch fire on a hot surface unit or heating element.



(continued next page)



IMPORTANT SAFETY INSTRUCTIONS

(continued)

- For your safety, never use your appliance for warming or heating the room.
- **DO NOT STORE OR USE COMBUSTIBLE MATERIALS, GASOLINE OR OTHER FLAMMABLE VAPORS AND LIQUIDS IN THE VICINITY OF THIS OR ANY OTHER APPLIANCE.**

- Keep the hood **and** grease filters clean to maintain good venting and to avoid grease fires,

- **Do not** let cooking grease or other flammable materials accumulate in or near the range.

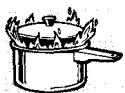

- Do not use water on grease fires. Never pick up a flaming pan.

Turn the controls off. Smother a flaming pan on a surface unit by covering the pan completely with a well-fitting lid, cookie sheet or flat tray. Use a multi-purpose dry chemical or foam-type fire extinguisher.

Flaming grease outside a pan can be put out by covering it with baking soda or, if available, by using a multi-purpose dry chemical or foam-type fire extinguisher.

Flame in the oven can be smothered completely by closing the oven door and turning the oven off or by using a multi-purpose dry chemical or foam-type fire extinguisher.

- Do not **touch** the surface units, the heating elements or the interior surface of the oven. These surfaces may be hot enough to burn even though they are dark in color. During and after use, do not touch, or let clothing or other flammable materials contact the surface units, the areas nearby the surface units or any interior area of the oven; allow sufficient time for cooling first.

Potentially hot surfaces include the cooktop, areas facing the cooktop, oven vent opening, surfaces near the opening, crevices around the oven door, the edges of the door window and metal trim parts above the door.

Remember: The inside surface of the oven may be hot when the door is opened.

- When cooking pork, follow the directions exactly and always cook the meat to an internal temperature of at least 170°F. This assures that, in the remote possibility that trichina may be present in the meat, it will be killed and the meat will be safe to eat.

Oven

- **Stand away from the range when opening the oven door. Hot air or steam which escapes can cause burns** to hands, face and/or eyes.

- **Do not heat** unopened **food** containers. Pressure could build up and the container **could burst**, causing an injury.

- Keep the oven vent duct unobstructed.

- Keep the oven free from grease buildup.

- Place the oven shelf in the desired position while the oven is **cool**. If the shelves must be handled when hot, do not let a pot holder contact the heating elements in the oven.

- Pulling out the shelf to the shelf stop is a convenience in lifting heavy foods. It is also **a** precaution against burns from touching **hot** surfaces of the door or oven walls.

- After broiling, **always** take the broiler pan out of the range and **clean** it. Leftover grease in the broiler pan can catch on fire next time you use the pan.

- When using cooking or roasting bags in the oven, follow the manufacturer's directions.

- * **Do not** use your oven to dry newspapers. If overheated, they can catch fire.

- Do not leave paper products, cooking utensils or food in the oven when not in use. Do not store flammable materials in an oven or near the surface units.

- Never leave jars or cans of fat dripping on or near your range.

Self-Cleaning Oven

- Do not **clean** the door gasket. The door gasket is essential for a good seal. Care should be taken not to rub, damage or move the gasket.

- Clean only parts listed in this Use and Care Guide.

- Do not use oven cleaners. No commercial oven cleaner or oven liner protective coating of any kind should be used in or around any part of the oven. Residue from oven cleaners will damage the inside of the oven when the self-clean cycle is used.



- **Do not use aluminum foil to line oven bottoms**, except as suggested in this guide. Improper installation of aluminum foil may result in a risk of electric shock or fire.
- **Be** sure to wipe up excess spillage **before** starting the **self-cleaning** operation.
- **Before** self-cleaning the oven, remove the broiler pan, **rack** and **other** cookware.
- **If** the self-cleaning mode malfunctions, turn the oven off and disconnect the power supply. Have it serviced by a qualified technician.

Surface Cooking Units

- Use proper pan size—Select cookware having flat bottoms large enough to cover the surface unit heating element. The use of undersized cookware will expose a portion of the surface unit to direct contact and may result in ignition of clothing. Proper relationship of the cookware to the surface unit will also improve efficiency.
- Never leave the surface units unattended at high heat settings. Boilovers cause smoking and greasy spillovers that may catch on fire.
- Be sure the drip pans and vent ducts are **not** covered and are in place. Their absence during cooking could damage range parts and wiring.
- Do not use aluminum foil **to line** the drip pans or anywhere in the oven except as described in this guide. Misuse could result in a shock, fire hazard or damage to the range.
- Never clean the **cooktop surface** when it is hot. Some cleaners produce noxious fumes and wet cloths could cause steam burns if used on a hot surface.
- Never leave **jars** or cans of fat drippings on or near your range.
- Only certain types of **glass, glass/ceramic, earthenware** or other **glazed containers** are suitable for **cooktop** service; others may break because of the sudden change in temperature.
- **To minimize the possibility of burns**, ignition of flammable materials and spillage, the handle of a container should be turned toward the center of the range without extending over nearby surface units.
- * Always turn **the surface units to off before** removing cookware.
- Keep an eye on **foods being fried** at high or medium high heat.
- To avoid the possibility of a burn or electric shock, always be certain that the controls for **all surface units are** at the **i-i position** and **all coils are cool** before attempting to lift or remove a unit.
- **Do not** immerse or soak the removable surface units. **Do not** put them in a dishwasher. **Do not clean the** surface units in the oven.
- Never try to move a pan of hot fat, especially a deep fat fryer. Wait until the fat is cool.
- When flaming foods are under the hood, turn the fan off. The fan, if operating, may spread the **flame**.
- Foods for **frying should** be as dry as possible. Frost on frozen foods or moisture on fresh foods can cause hot fat to bubble up and over the sides of the pan.
- Use little fat for effective shallow or deep-fat **frying**. Filling the pan too full of fat can cause spillovers when food is added.
- If a combination of oils or fats **will** be used **in frying**, stir together before heating, or as fats melt **slowly**.
- * Always heat fat slowly, and watch as it heats.
- **Use a deep fat thermometer whenever possible** to prevent overheating fat beyond the smoking point.

**SAVE THESE
INSTRUCTIONS**



FEATURES OF YOUR RANGE

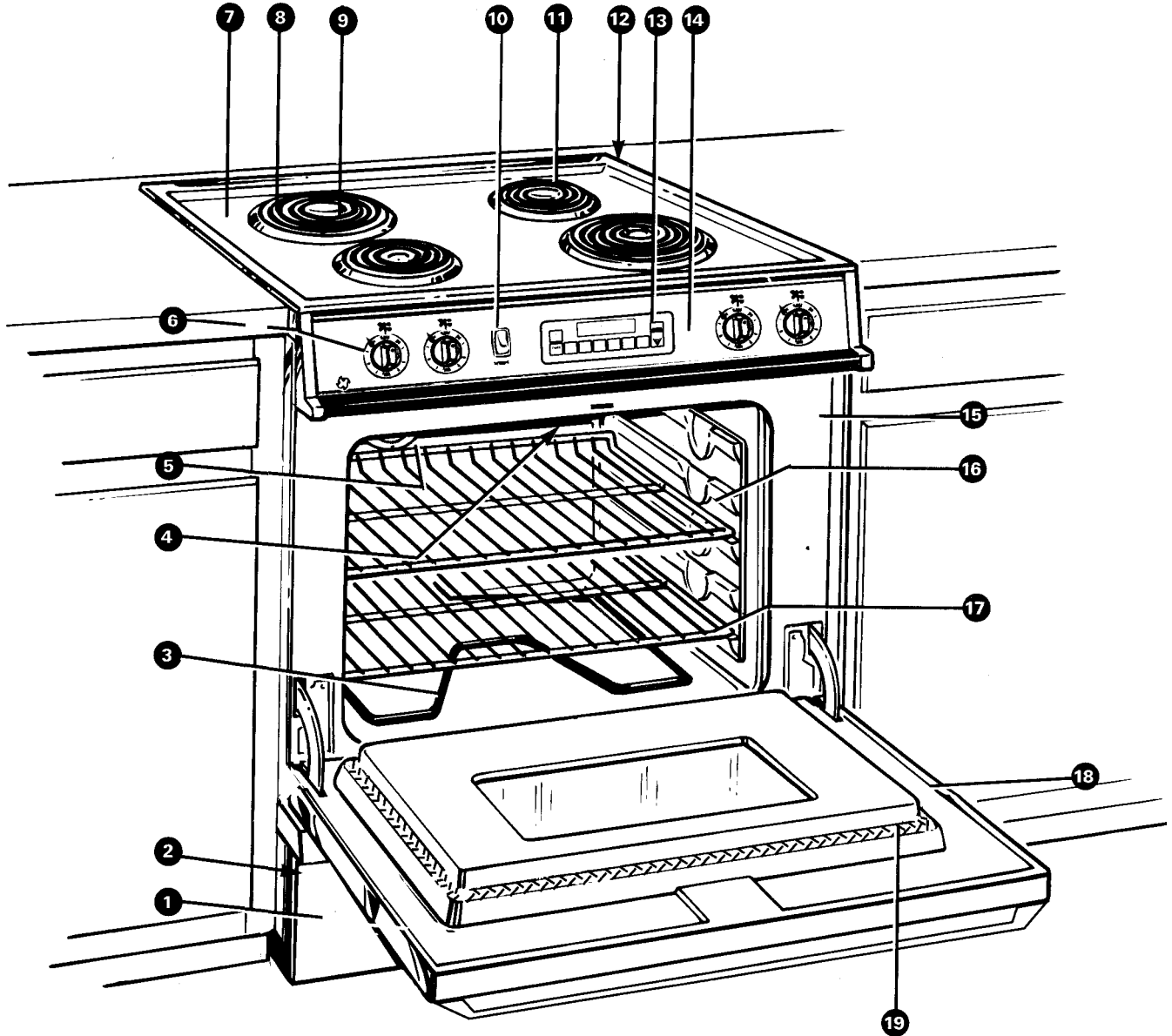

Models
JSP26
JSP31

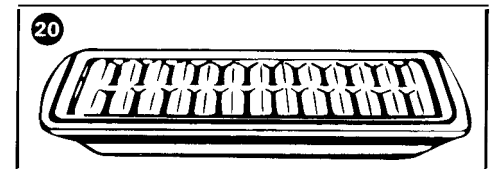

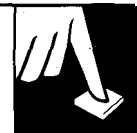

Feature Index	Explained on page
1 Storage Drawer	3,30
2 Model and Serial Numbers	2
3 Bake Element	24
4 Broil Element	22,24
5 Oven Interior Light	14,31
6 Surface Unit Controls	5,8,28
7 Lift-Up Cooktop Support rod holds it up to simplify cleaning underneath.	29
8 Drip Pans	5,28
9 Plug-In Surface Units	3-5, 8-11,28
10 Oven Light Switch Lets you turn interior oven light on and off.	14
11 Oven Vent (located under right rear surface unit)	4,29
12 Anti-Tip Device	3,32
13 Oven Control, Clock and Timer	8,9, 12, 13, 19,28
14 Surface Unit "ON" Indicator Light	9
15 Automatic Oven Light Switch	14
16 Oven Shelf Supports Shelf position for cooking are suggested in the Baking, Roasting and Broiling sections.	4, 14, 15
17 Oven Shelves with Stop-Locks	4, 14, 15, 26,31
18 Lift-Off Oven Door with Broil Stop Position	3,4,22 24,30
19 Oven Door Gasket	4,24,30
20 Broiler Pan and Rack Do not clean in the self-cleaning oven.	4,5,22-24, 31







HOW DOES THIS COOKTOP COMPARE TO YOUR OLD ONE?

Your new cooktop has electric coil surface units. If you are used to cooking with gas burners or other types of electric cooktops, you will notice some differences when you use electric coils.

The best types of cookware to use, plus heat-up and cool-down times, depend upon the type of burner or surface unit you have.

The following chart will help You to understand the differences between electric coil surface units and any other type of cooktop you may have used in the past.

Type of Cooktop	Description	How it Works
Electric Coil 	Flattened metal tubing containing electric resistance wire suspended over a drip pan.	Heats by direct contact with the pan and by heating the air under the pan. For best cooking results, use good quality pans. Electric coils are more forgiving of warped pans than radiant or solid disks. Heats up quickly but does not change heat settings as quickly as gas or induction. Electric coils stay hot enough to continue cooking for a short time after they are turned off.
Radiant (Glass Ceramic) Cooktop 	Electric coils under a glass-ceramic cooktop.	Heat travels to the glass surface and then to the cookware, so pans must be flat on the bottom for good cooking results. The glass cooktop stays hot enough to continue cooking after it is turned off. Remove the pan from the surface unit if you want cooking to stop.
Induction 	High frequency induction coils under a glass surface.	Pans must be made of ferrous metals (metal that attracts a magnet). Heat is produced by a magnetic circuit between the coil and the pan. Heats up right away and changes heat settings right away, like a gas cooktop. After turning the control off, the glass cooktop is hot from the heat of the pan, but cooking stops right away.
Solid Disk 	Solid cast iron disk sealed to the cooktop surface.	Heats by direct contact with the pan, so pans must be flat on the bottom for good cooking results. Heats up and cools down more slowly than electric coils. The disk stays hot enough to continue cooking after it is turned off. Remove the pan from the solid disk if you want the cooking to stop.
Gas Burners 	Regular or sealed gas burners use either LP gas or natural gas.	Flames heat the pans directly. Pan flatness is not critical to cooking results, but pans should be well balanced. Gas burners heat the pan right away and change heat settings right away. When you turn the control off, cooking stops right away.

SURFACE CONTROLS

At both OFF and HI the control “clicks” into position.

You may hear slight “clicking” sounds during cooking, indicating the control is keeping the unit at the heat level or power level you set.

Switching heats to higher settings always shows a quicker change than switching to lower settings.



How to Set the Controls

1. Grasp the control knob and push in.

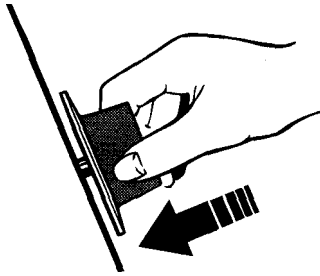

The control must be pushed in to set only from the OFF position. When the control is in any position other than OFF, it may be turned without pushing it in.

Be sure you turn the control knob to OFF when you finish cooking.

The surface unit “on” indicator light will glow when ANY heat on any surface unit is on.

2. Turn the knob either clockwise or counterclockwise to the desired heat setting.

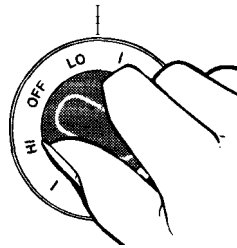

Cooking Guide for Using Heat Settings

HI—Quick start for cooking; bring water to boil.

Medium High—Fast fry, pan broil; maintain fast boil on large amount of food.

MED—Sauté and brown; maintain slow boil on large amount of food.

Medium Low—Steam rice, cereal; maintain serving temperature of most foods.

LO—Cook after starting at **HI**; cook with little water in covered pan.

NOTE:

1. At **HI** and **Medium High**, never leave food unattended. Boilovers cause smoking; greasy spillovers may catch fire.
2. At **Medium Low** or **LO**, melt chocolate, butter on a small unit.

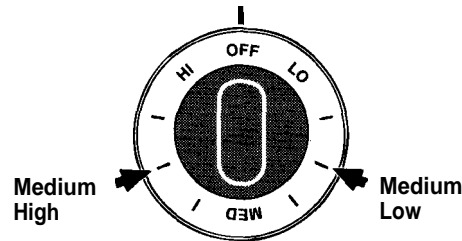



SURFACE COOKWARE TIPS

Wok Cooking

We recommend that you use only a flat-bottomed wok. They are available at your local retail store.



Do not use woks that have support rings.

Use of these types of woks, without the support ring in place, is dangerous because the wok is unstable. With the ring in place, heat will be trapped inside the ring and may cause damage to the porcelain cooktop. Do not try to use such woks without the ring. You could be seriously burned if the wok tipped over.

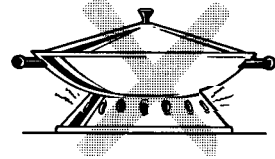

Cookware

Use medium- or heavy-weight cookware. Aluminum cookware conducts heat faster than other metals. Cast-iron and coated cast-iron cookware are slow to absorb heat, but generally cook evenly at low to medium heat settings. Steel pans may cook unevenly if not combined with other metals.

For best cooking results pans should be flat on the bottom. Match the size of the saucepan to the size of the surface unit. The pan should not extend over the edge of the surface unit more than 1 inch.

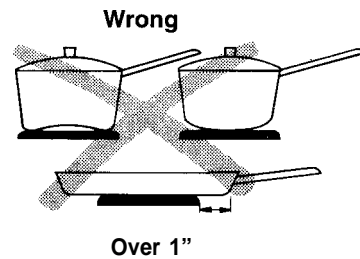
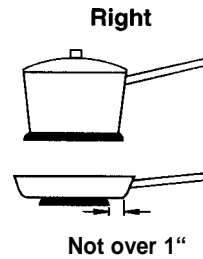

Deep Fat Frying

Do not overfill cookware with fat that may spill over when adding food. Frosty foods bubble vigorously. Watch food frying at high temperatures. Keep the range and hood clean from grease.

HOME CANNING TIPS



Canning should be done on surface units only.

In surface cooking, the use of pots extending more than one inch beyond the edge of the surface unit's drip pan is not recommended. However, when canning with a water-bath or pressure canner, large-diameter pots may be used. This is because boiling water temperatures (even under pressure) are not harmful to the cooktop surfaces surrounding the surface units.

HOWEVER, DO NOT USE LARGE-DIAMETER CANNERS OR OTHER LARGE-DIAMETER POTS FOR FRYING OR BOILING FOODS OTHER THAN WATER. Most syrup or sauce mixtures—and all types of frying-cook at temperatures much higher than boiling water. Such temperatures could eventually harm the cooktop surfaces surrounding the surface units.

Observe Following Points in Canning

1. Be sure the canner fits over the center of the surface unit. If your range or its location does not allow the canner to be centered on the surface unit, use smaller-diameter pots for good canning results.
2. Flat-bottomed canners must be used. Do not use canners with flanged or rippled bottoms (often found in enamelware) because they don't make enough contact with the surface unit and take too long to boil water.
3. When canning, use recipes and procedures from reputable sources. Reliable recipes and procedures are available from the manufacturer of your canner, manufacturers of glass jars for canning, such as Ball and Kerr, and the United States Department of Agriculture Extension Service.
4. Remember that canning is a process that generates large amounts of steam. To avoid burns from steam or heat, be careful when canning.

RIGHT

WRONG



Flat-bottomed canners are recommended.

NOTE: If your house has low voltage, canning may take longer than expected, even though directions have been carefully followed.

The process time will be shortened by:

- (1) using a pressure canner, and
- (2) starting with HOT tap water for fastest heating of large quantities of water.



FEATURES OF YOUR OVEN CONTROL

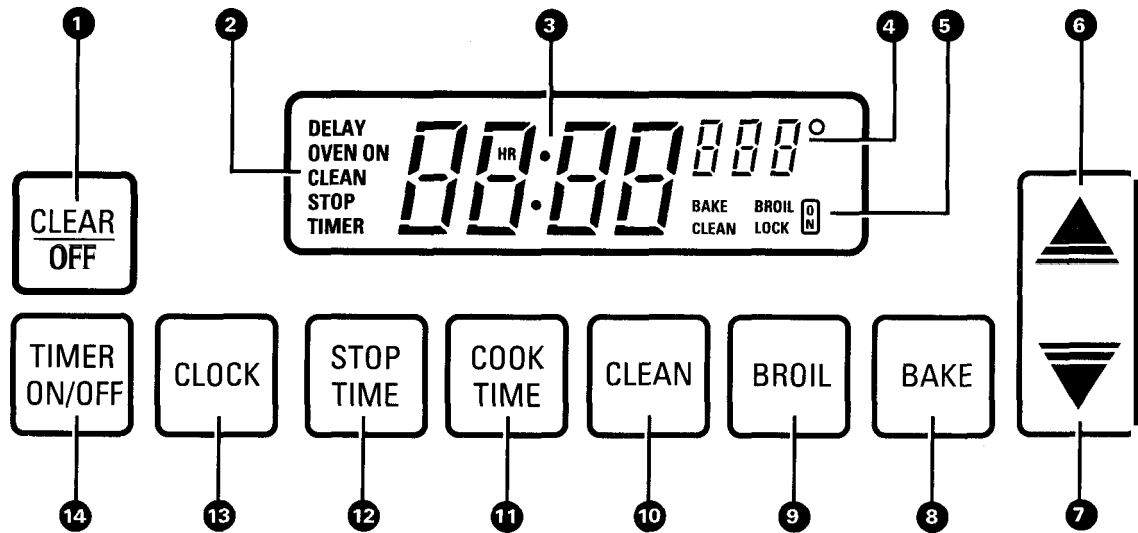

- 1. CLEAR/OFF.** Press this pad to cancel all oven operations except clock and timer.
- 2. PROGRAM STATUS.** Words light up in the display to indicate what is in time display.
Programmed information can be displayed at any time by pressing the pad of the operation you want to see. For example, you can display the current time of day while the timer is counting down by pressing the CLOCK pad.
- 3. TIME DISPLAY.** Shows the time of day, the times set for the timer or automatic oven operation.
- 4. OVEN TEMPERATURE AND BROIL DISPLAY.** Shows the oven temperature or the broil setting selected.
- 5. FUNCTION INDICATORS.** Lights up to show whether the oven is in the bake, broil or self-clean mode.
- 6. INCREASE.** Short taps to this pad increase the time or temperature by small amounts. Press and hold the pad to increase the time or temperature by larger amounts.
- 7. DECREASE.** Short taps to this pad decrease the time or temperature by small amounts. Press and hold the pad to decrease the time or temperature by larger amounts.
- 8. BAKE.** Press this pad to select the bake function.
- 9. BROIL.** Press this pad to select the broil function.
- 10. CLEAN.** Press this pad to select the self-cleaning function. See the Operating the Self-Cleaning Oven section.
- 11. COOK TIME.** Press this pad for Timed Baking operations.
- 12. STOP TIME.** Use this pad along with the COOK TIME or CLEAN pad to stop automatically at a time you select.
- 13. CLOCK.** To set clock, first press the CLOCK pad. Then press the INCREASE or DECREASE pad to change the time of day.
- 14. TIMER ON/OFF.** Press this pad to select the timer function.
To set the timer, first press the TIMER ON/OFF pad. Then press the INCREASE or DECREASE pad to change the time.
To cancel the timer, press and hold the TIMER ON/OFF pad until the word "TIMER" disappears from the display.

If "F-" and a number flash in the display and the oven control signals, this indicates function error code. Press the CLEAR/OFF pad. Allow the oven to cool for one hour. Put the oven back into operation. If the function error code repeats, disconnect the power to the range and call for service.

OVEN CONTROL, CLOCK AND TIMER



Clock

The clock must be set for the automatic oven timing functions to work properly. The time of day cannot be changed during a Timed Bake or CLEAN cycle.

To Set the Clock

1. Press the CLOCK pad.

CLOCK

c1



2. Press the INCREASE or DECREASE pad to set the time of day.

Timer

The timer is a minute timer; it does not control oven operations. The maximum setting on the timer is 9 hours and 55 minutes.

To Set the Timer



1. Press the TIMER ON/OFF pad.
2. Press the INCREASE or DECREASE pad to set the amount of time on the timer.

The timer will start automatically within a few seconds of releasing the pad. The timer, as you are setting it, will display seconds until 1 minute is reached. Then it will display minutes and seconds until 10 minutes is reached.

After 10 minutes, it will display hours ("HR" now appears in display) and minutes until the maximum time of 9 hours and 55 minutes is reached.

To Reset the Timer

If "TIMER" is displayed, press the INCREASE or DECREASE pad until desired time is reached.

If "TIMER" is not displayed, press the TIMER ON/OFF pad first, then follow the instructions above to set the timer.

To Cancel the Timer

Press and hold the TIMER ON/OFF pad until the word "TIMER" disappears from the display.

End of Cycle Tone

The end of cycle tone is a series of 3 beeps followed by 1 beep every 6 seconds. If you would like to remove the signal that beeps every 6 seconds, press and hold the CLEAR/OFF pad for 10 seconds.

To return the signal that beeps every 6 seconds, press and hold the CLEAR/OFF pad for 10 seconds.

Display Messages

If "door" appears in the display, the door is open. Close the door. If "LOCK" appears in the display, the oven door is in the locked position. BAKE, BROIL and COOK TIME cannot be set if the door is in the locked position.

Power Outage

After a power outage, when power is restored, the display will flash and time shown will no longer be correct-for example, after a 5-minute power interruption the clock will be 5 minutes slow.

All other functions that were in operation when the power went out will have to be programmed again.



USING YOUR OVEN

Before Using Your Oven

1. Look at the controls. Be sure you understand how to set them properly. Read over the directions for the Oven Controls so you understand how to use them.
2. Check the oven interior. Look at the shelves. Take a practice run at removing and replacing them properly, to give sure, sturdy support.
3. Read over the information and tips that follow.
4. Keep this guide handy so you can refer to it, especially during the first weeks of using your new range.

NOTE:

- You may notice a “burning” or “oily” smell the first few times you turn your oven on. This is normal in a new oven and will disappear in a short time. To speed the process, set a self-clean cycle for a minimum of 3 hours. See the Operating the Self-Cleaning Oven section.
- A fan may automatically turn on and off to cool internal parts. This is normal and the fan may continue to run even after the oven is turned off.

Oven Light

The oven light comes on automatically when the door is opened.

Use the switch on the control panel to turn the oven light on when the door is closed.

Shelf Positions

The oven has four shelf supports identified in this illustration as A (bottom), B, C and D (top).

Shelf positions for cooking are suggested in the Baking, Roasting, and Broiling sections.

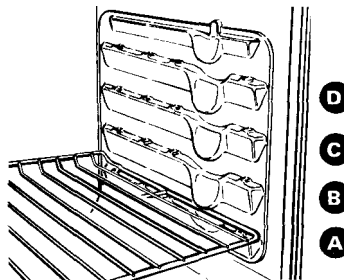

Oven Shelves

The shelves are designed with stop-locks so when placed correctly on the shelf supports, they will stop before coming completely out of the oven and will not tilt when you are removing food from them or placing food on them.

When placing cookware on a shelf, pull the shelf out to the “stop” position. Place the cookware on the shelf, then slide the shelf back into the oven. This will eliminate reaching into the hot oven.

To remove the shelf from the oven, pull it toward you, tilt the front end upward, and pull it out.

To replace, place the shelf on the shelf support with the stop-locks (curved extension of shelf) facing up and toward the rear of the oven. Tilt up the front and push the shelf toward the back of the oven until it goes past the bump on the shelf support. Then lower the front of the shelf, and push it all the way back.



BAKING



Your oven temperature is controlled very accurately using an oven control system. We recommend that you operate the range for a number of weeks using the time given on recipes as a guide to become familiar with your new oven's performance.

If you think an adjustment is necessary, see the Adjust the Oven Thermostat section. It gives easy Do It Yourself instructions on how to adjust the thermostat. NOTE: When the oven gets hot, the top and outside surfaces of the range get hot too.

How to Set Your Range for Baking

To avoid possible burns, place shelves in the correct position before you turn the oven on.

1. Press the **BAKE** pad.
2. Press the **INCREASE** or **DECREASE** pad until the desired temperature is displayed.

The oven will start automatically. The word "ON" and "100°" will be displayed. As the oven heats up, the display will show the changing temperature. When the oven reaches the temperature you set, a tone will sound.

3. Press the **CLEAR/OFF** pad when baking is finished and then remove the food from the oven.

NOTE: A fan may automatically turn on and off to cool internal parts. This is normal and the fan may continue to run after the oven is turned off.

To **change the oven temperature during BAKE cycle**, press the **BAKE** pad and then the **INCREASE** or **DECREASE** pad to get the new temperature.

Oven Shelves

Arrange the oven shelf or shelves in the desired locations while the oven is cool. The correct shelf position depends on the kind of food and the browning desired. As a general rule, place most foods in the middle of the oven, on either shelf positions B or C. See the chart for suggested shelf positions.

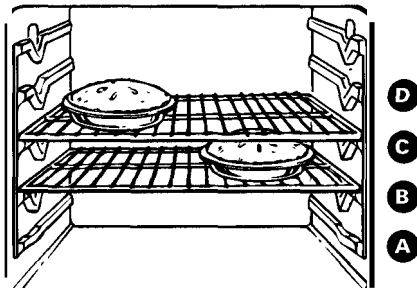

Type of Food	Shelf Position
Angel food cake	A
Biscuits or muffins	B or C
Cookies or cupcakes	B or C
Brownies	B or C
Layer cakes	B or C
Bundt or pound cakes	A or B
Pies or pie shells	B or C
Frozen pies	A (on cookie sheet)
Casseroles	B or C
Roasting	A or B

Preheating

Preheat the oven if the recipe calls for it. Preheat means bringing the oven up to the specified temperature before putting the food in the oven. To preheat, set the oven at the correct temperature—selecting a higher temperature does not shorten preheat time.

Preheating is necessary for good results when baking cakes, cookies, pastry and breads. For most casseroles and roasts, preheating is not necessary. For ovens without a preheat indicator light or tone, preheat 10 minutes. After the oven is preheated, place the food in the oven as quickly as possible to prevent heat from escaping.

(continued next page)



BAKING

(continued)

Baking Pans

Use the proper baking pan. The type of finish on the pan determines the amount of browning that will occur.

- Dark, rough or dull pans absorb heat resulting in a browner, crisper crust. Use this type for pies.
- Shiny, bright and smooth pans reflect heat, resulting in a lighter, more delicate browning. Cakes and cookies require this type of pan.
- Glass baking dishes absorb heat. When baking in glass baking dishes, the temperature may need to be reduced by 25°F.

Pan Placement

For even cooking and proper browning, there must be enough room for air circulation in the oven. Baking results will be better if baking pans are centered as much as possible rather than being placed to the front or to the back of the oven.

Pans should not touch each other or the walls of the oven. Allow 1- to 1½-inch space between pans as well as from the back of the oven, the door and the sides. If you use two shelves, stagger the pans so one is not directly above the other.

Baking Guides

When using prepared baking mixes, follow package recipe or instructions for the best baking results.

Cookies

When baking cookies, flat cookie sheets (without sides) produce better-looking cookies. Cookies baked in a jelly roll pan (short sides all around) may have darker edges and pale or light browning may occur.

Do not use a cookie sheet so large that it touches the walls or the door of the oven. Never entirely cover a shelf with a large cookie sheet.

For best results, use only one cookie sheet in the oven at a time.

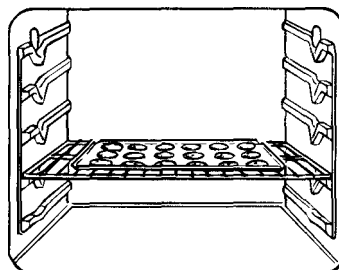

Pies

For best results, bake pies in dark, rough or dull pans to produce a browner, crisper crust. Frozen pies in foil pans should be placed on an aluminum cookie sheet for baking since the shiny foil pan reflects heat away from the pie crust; the cookie sheet helps retain it.

Cakes

When, baking cakes, warped or bent pans will cause uneven baking results and poorly shaped products. A cake baked in a pan larger than the recipe recommends will usually be crisper, thinner and drier than it should be. If baked in a pan smaller than recommended, it may be undercooked and batter may overflow. Check the recipe to make sure the pan size used is the one recommended.

Aluminum Foil

Never entirely cover a shelf with aluminum foil. This will disturb the heat circulation and result in poor baking. A smaller sheet of foil may be used to catch a spillover by placing it on a lower shelf several inches below the food.

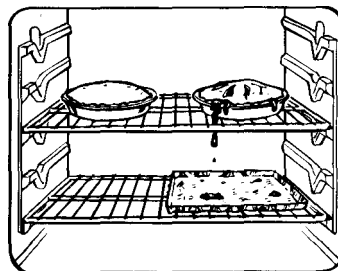



Don't Peek

Set the timer for the estimated cooking time and do not open the door to look at your food. Most recipes provide minimum and maximum baking times such as "bake 30-40 minutes."

DO NOT open the door to check until the minimum time. Opening the oven door frequently during cooking allows heat to escape and makes baking times longer. Your baking results may also be affected.

TIMED BAKING

How to Time Bake

The oven control allows you to turn the oven on or off automatically at specific times that you set.

NOTE: Before beginning make sure the clock shows the correct time of day.

To **set the clock**, first press the CLOCK pad. Press the INCREASE or DECREASE pad until the correct time of day is displayed.

How to Set Immediate Start and Automatic Stop

To avoid possible burns, place the shelves in the correct position before you turn the oven on.

The oven will turn on immediately and cook for a selected length of time. At the end of Cook Time, the oven will turn off automatically.

The oven will start automatically. The word "ON" and "100" will be displayed. The Cook Time will begin to count down. As the oven heats up, the display will show the changing temperature.

When the oven reaches the temperature you set, a tone will sound. The oven will continue to cook for the programmed amount of time, then shut off automatically.



1. Press the COOK TIME pad.

NOTE: If your recipe requires preheating, you may need to add additional time to the length of the Cook Time.

2. Press the INCREASE pad until the desired length of baking time appears in the display.

3. Press the BAKE pad.



5. Press the CLEAR/OFF pad to clear the display if necessary. Remove the food from the oven. Remember, even though the oven shuts off automatically, foods continue cooking after the controls are off.

NOTE:

- Foods that spoil easily, such as milk, eggs, fish, stuffings, poultry and pork, should not be allowed to sit for more than one hour before or after cooking. Room temperature promotes the growth of harmful bacteria. Be sure that the oven light is off because heat from the bulb will speed harmful bacteria growth.
- A fan may automatically turn on and off to cool internal parts. This is normal and the fan may continue to run after the oven is turned off.

(continued next page)



TIMED BAKING

(continued)

How to Set Delay Start and Automatic Stop

Quick Reminder:

1. Press the COOK TIME pad.
2. Press the INCREASE/DECREASE pad to set the Cooking Time.
3. Press the STOP TIME pad.
4. Press the INCREASE/DECREASE pad to set the length of Cooking Time.
5. Press the BAKE pad.
6. Press the INCREASE/DECREASE pad until the desired temperature appears in the display.

To avoid possible burns, place the shelves in the correct position before you turn the oven on.



You can set the oven control to delay-start the oven, cook for a specific length of time and then turn off automatically.

For example: Let's say it's 2:00 and dinner time is shortly after 7:00. The recipe suggests 3 hours baking time at 325°F. Here's how:

1. Press the COOK TIME pad.

**COOK
TIME**
c1

NOTE: If your recipe requires preheating, you may need to add additional time to the Cook Time.

2. For 3 hours of cooking time, press the INCREASE pad until "3:00" appears in the display.

3. Press the STOP TIME pad.

**STOP
TIME**
n

The display prompts you to set the Stop Time you want. It also shows the earliest Stop Time you can set. In this example, the time of day is 2:00 and the Cook Time is 3 hours. Adding 3 hours to the time of day equals 5:00.

4. Change the Stop Time from 5:00 to 7:00 by pressing the INCREASE pad until "7:00" appears in the display.



5. Press the BAKE pad.

6. Press the INCREASE or DECREASE pad until "325°" is displayed.

At 4:00, the oven will turn on automatically. The word "ON" and "100°" will be displayed. The Cook Time will begin to count down. As the oven heats up, the display will show the changing temperature. The oven will continue to cook for the programmed 3 hours and shut off automatically at 7:00.



7. Press the CLEAR/OFF pad to clear the display if necessary. Remove the food from the oven. Remember, even though the oven shuts off automatically, foods continue cooking after the controls are off.

NOTE:

- The low temperature zone of this range (between 150°F and 200°F) is available to keep hot cooked foods warm. Food kept in the oven longer than 2 hours at these low temperatures may spoil.
- Foods that spoil easily, such as milk, eggs, fish, stuffings, poultry and pork, should not be allowed to sit for more than one hour before or after cooking. Room temperature promotes the growth of harmful bacteria. Be sure the oven light is off because heat from the bulb will speed harmful bacteria growth.
- A fan may automatically turn on and off to cool internal parts. This is normal and the fan may continue to run after the oven is turned off.

ADJUST THE OVEN THERMOSTAT— *DO IT YOURSELF!*



You may feel that your new oven cooks differently than the one it replaced. We recommend that you use your new oven for a few weeks to become more familiar with it, following the times given in your recipes as a guide.

If you think your new oven is too hot or too cold, you can adjust the thermostat yourself. If you think it is too hot, adjust the thermostat to make it cooler. If you think it is too cool, adjust the thermostat to make it hotter.

We **do not recommend the use of inexpensive thermometers**, such as those found in grocery stores, to check the temperature setting of your new oven. These thermometers may vary 20-40 degrees.

To Adjust the Thermostat:

1. Press the BAKE pad.

BAKE



2. Select an oven temperature between 500°F and 550°F.
3. Immediately, before the BAKE indicator stops flashing, press and hold the BAKE pad for about 4 seconds. The display will change to the oven adjustment display.
4. The oven temperature can be adjusted up to (+) 35°F hotter or (-) 35°F cooler. Use the INCREASE or DECREASE pads to select the desired change in the display.
5. After you have made the adjustment, press the CLEAR/OFF pad to go back to the time of day display. Use your oven as you would normally.



NOTE: This adjustment will not affect the broiling or self-cleaning temperatures. It will be retained in memory after a power failure.



ROASTING

Roasting is cooking by dry heat. Tender meat or poultry can be roasted uncovered in your oven. Roasting temperatures, which should be low and steady, keep spattering to a minimum.

Roasting is really a baking procedure used for meats. Therefore, oven controls are set for Baking or Timed Baking. (You may hear a slight clicking sound, indicating the oven is working properly.) Timed Baking will turn the oven on and off automatically.

Most meats continue to cook slightly while standing, after being removed from the oven. Standing time recommended for roasts is 10 to 20 minutes. This allows roasts to firm up and makes them easier to carve. Internal temperature will rise about 5° to 10°F; to compensate for temperature rise, if desired, remove the roast from oven sooner (at 5° to 10°F. less than temperature in the Roasting Guide).

Remember that food will continue to cook in the hot oven and therefore should be removed when the desired internal temperature has been reached.

1. Place the shelf in A or B position. No preheating is necessary.

2. Check the weight of the meat. Place the meat fat-side-up, or poultry breast-side-up, on roasting rack in a shallow pan. The melting fat will baste the meat. Select a pan as close to the size of the meat as possible. (The broiler pan with rack is a good pan for this.)

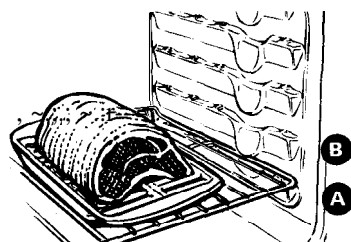

The oven will start automatically. The word "ON" and "100°" will be displayed. As the oven heats up, the display will show the changing temperature. When the oven reaches the temperature you set, a tone will sound.

5. Press the CLEAR/OFF pad when roasting is finished and then remove the food from the oven.

NOTE: A fan may automatically turn on and off to cool internal parts. This is normal and the fan may continue to run after the oven is turned off.



3. Press the BAKE pad.

4. Press the INCREASE or DECREASE pad until the desired temperature is displayed.

To change the oven temperature during the roasting cycle, press the BAKE pad and then the INCREASE or DECREASE pad to get the new temperature.

Use of Aluminum Foil

You can use aluminum foil to line the broiler pan. This makes clean-up easier when using the pan for marinating, cooking with fruits, cooking heavily cured meats or basting food during cooking. Press the foil tightly around the inside of the pan.





Questions and Answers

Q. Is it necessary to check for doneness with a meat thermometer?

A. Checking the finished internal temperature at the completion of cooking time is recommended. Temperatures are shown in the Roasting Guide section. For roasts over 8 pounds, check with thermometer at half-hour intervals after half the cooking time has passed.

Q. Why is my roast crumbling when I try to carve it?

A. Roasts are easier to slice if allowed to cool 10 to 20 minutes after removing them from the oven. Be sure to cut across the grain of the meat.

Q. Do I need to preheat my oven each time I cook a roast or poultry?

A. It is not necessary to preheat your oven.

Q. When buying a roast, are there any special tips that would help me cook it more evenly?

A. Yes. Buy a roast as even in thickness as possible, or buy rolled roasts.

Q. Can I seal the sides of my foil "tent" when roasting a turkey?

A. Sealing the foil will steam the meat. Leaving it unsealed allows the air to circulate and brown the meat.

ROASTING GUIDE

Frozen Roasts

Frozen roasts of beef, pork, lamb, etc., can be started without thawing, but allow 10 to 25 minutes per pound additional time (10 minutes per pound for roasts under 5 pounds, more time for larger roasts).

Make sure poultry is thawed before roasting. Unthawed poultry often does not cook evenly. Some commercial frozen poultry can be cooked successfully without thawing. Follow the directions given on the package label.

Type	Oven Temperature	Doneness	Approximate Roasting Time in Minutes per Pound		Internal Temperature "F.
Meat Tender cuts; rib, high quality sirloin tip, rump or top round*	325°	Rare:	3 to 5 lbs. 24-33	6 to 8 lbs. 18-22	140°-150°† 150°-1600 170°-1850
		Medium:	35-39	22-29	
		Well Done:	40-45	30-35	
Lamb leg or bone-in shoulder*	325°	Rare:	21-25	20-23	140°-15007 150°-1600 170°-1850
		Medium:	25-30	24-28	
		Well Done:	3&35	28-33	
Veal shoulder, leg or loin*	325°	Well Done:	35-45	30-40	170°-1800
Pork loin, rib or shoulder*	325°	Well Done:	3545	3040	170°-1800
Ham, precooked	325°	To Warm:	17-20 minutes per pound (any weight)		115°-1200
Poultry Chicken or Duck	325°	Well Done:	3 to 5 lbs. 3540	Over 5 lbs. 30-35	185°-1900 185°-1900
	350°	Well Done:	35-40		
Chicken pieces			10 to 15 lbs.	Over 15 lbs.	In thigh: 185°-1900
Turkey	325°	Well Done:	18-25	15-20	185°-1900

*For boneless rolled roasts over 6 inches thick, add 5 to 10 minutes per pound to times given above.

†The U. S. Department of Agriculture says "Rare beef is popular, but you should know that cooking it to only 140°F. means some food poisoning organisms may survive." (Source: Safe Food Book. Your Kitchen Guide. USDA Rev. June 1985.)





BROILING

Broiling is cooking food by intense radiant heat from the upper broil element in the oven. Most fish and tender cuts of meat can be broiled. Follow these directions to keep spattering and smoking to a minimum.

Turn the food only once during broiling. Time the foods for the first side according to the Broiling Guide. Turn the food, then use the times given for the second side as a guide to the preferred doneness.

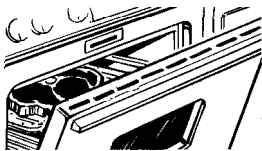
1. If the meat has fat or gristle around the edge, cut vertical slashes through both about 2 inches apart. If desired, the fat may be trimmed, leaving a layer about 1/8 inch thick.
2. Place the meat on the broiler rack in the broiler pan. Always use the rack so the fat drips into the broiler pan; otherwise the juices may become hot enough to catch on fire.
3. Position a flat shelf on recommended shelf position as suggested in the Broiling Guide. Most broiling is done on C position, **but if your range is connected to 208 volts, you may wish to use a higher position.**
4. Leave **the door open to the broil stop position.** The door stays open by itself, yet the proper temperature is maintained in the oven.



 **5. Press the BROIL pad.**
BROIL
u

6. Press the INCREASE pad once for LO Broil or twice for HI Broil.
To change from HI Broil to LO Broil, press the BROIL pad then press the DECREASE pad once.
7. When broiling is finished, press the CLEAR/OFF pad. Serve the food immediately, and leave the pan outside the oven to cool during the meal for easiest cleaning.

NOTE: A fan may automatically turn on and off to cool internal parts. This is normal and the fan may continue to run after the oven is turned off.

Use of Aluminum Foil

You can use aluminum foil to line your broiler pan and broiler rack. However, you must mold the foil tightly to the rack and cut slits in it just like the rack.

Without the slits, the foil will prevent fat and meat juices from draining to the broiler pan. The juices could become hot enough to catch on fire. If you do not cut the slits, you are frying, not broiling.

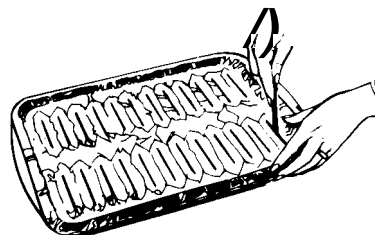

Questions and Answers

Q. Should I salt the meat before broiling?

A. No. Salt draws out the juices and allows them to evaporate. Always salt after cooking. Turn the meat with tongs; piercing the meat with a fork also allows the juices to escape. When broiling poultry or fish, brush each side often with butter.

Q. Do I need to grease my broiler rack to prevent meat from sticking?

A. No. The broiler rack is designed to reflect broiler heat, thus keeping the surface cool enough to prevent the meat from sticking to the surface. However, spraying the broiler rack lightly with a vegetable cooking spray before cooking will make clean-up easier.

Q. When broiling, is it necessary to always use a rack in the pan?

A. Yes. Using the rack suspends the meat over the pan. As the meat cooks, the juices fall into the pan, thus keeping the meat drier. Juices are protected by the rack and stay cooler, thus preventing excessive spatter and smoking.

Q. Why are my meats not turning out as brown as they should?

A. In some areas, the power (voltage) to the range may be low. In these cases, preheat the broil element for 10 minutes before placing the broiler pan with food in the oven. Check to see if you are using the recommended shelf position. Broil for the longest period of time indicated in the Broiling Guide. Turn the food only once during broiling. You may need to move the food to a higher shelf position.

BROILING GUIDE



Always use the broiler pan and rack that comes with your oven. It is designed to minimize smoking and spattering by trapping the juices in the shielded lower part of the pan.

- The oven door should be open to the broil stop position.
- For steaks and chops, slash fat evenly around the outside edges of the meat. To slash, cut crosswise through the outer fat surface just to the edge of the meat. Use tongs to turn the meat over to prevent piercing the meat and losing the juices.
- If desired, marinate meats or chicken before broiling, or brush with barbecue sauce last 5 to 10 minutes only.
- When arranging food on the pan, do not let fatty edges hang over the sides because dripping fat could soil the oven bottom.
- The broiler does not need to be preheated. However, for very thin foods, or to increase browning, preheat if desired.
- Use LO Broil to cook foods such as poultry or thick pork chops thoroughly without over-browning them.
- Frozen steaks can be broiled by positioning the oven shelf at next lowest shelf position and increasing cooking time given in this guide 1 ½ times per side.
- **If your range is connected to 208 volts, rare steaks may be broiled by preheating the broiler and positioning the oven shelf one position higher.**

Food	Quantity and/or Thickness	Shelf Position	First Side Time. Minutes	Second Side Time. Minutes	Comments
Bacon	1/2 lb. (about 8 thin slices)	C	4½	4½	Arrange in single layer.
Ground Beef Well Done	1 lb. (4 patties) 1/2 to 3/4 inch thick	C	10	7	Space evenly. Up to 8 patties take about same time.
Beef Steaks	1 inch thick (1 to 1½ lbs.) 1½ inch thick (2 to 2½ lbs.)	C	6	5	Steaks less than 1 inch thick cook through before browning. Pan frying is recommended. Slash fat.
Rare		C	8	6	
Medium		C	12	11	
Well Done		C	10	7-8	
Rare		C	15	14-16	
Medium	C	25	20-25		
Well Done					
Chicken	1 whole (2 to 2½ lbs.), split lengthwise	A	35	10-15	Reduce time about 5 to 10 minutes per side for cut-up chicken. Brush each side with melted butter. Broil skin-side-down first.
Bakery Products	2 to 4 slices 1 pkg. (2) 2 (split)	C or D	1½-2	1/2	Space evenly. Place English muffins cut-side-up and brush with butter, if desired.
Bread (Toast) or Toaster Pastries		C or D	3-4		
English Muffins					
Lobster Tails	2-4 (6 to 8 oz. each)	B	13-16	Do not turn over.	Cut through back of shell. Spread open. Brush with melted butter before broiling and after half of broiling time.
Fish	1-lb. fillets 1/4 to 1/2 inch thick	C	5	5	Handle and turn very carefully. Brush with lemon butter before and during cooking, if desired. Preheat broiler to increase browning.
Ham Slices (precooked)	1 inch thick	B	8	8	Increase time 5 to 10 minutes per side for 1 ½ inch thick or home cured ham.
Pork Chops Well Done	2 (1/2 inch thick) 2(1 inch thick), about 1 lb.	C B	10 13	10 13	Slash fat.
Lamb Chops	2 (1 inch thick), about 10 to 12 oz. 2(1 ½ inch thick), about 1 lb.	C	10	9	Slash fat.
Medium		C	12	10	
Well Done		c	14	12	
Medium Well Done		B	17	12-14	
Wieners and similar precooked sausages, bratwurst	1-lb. pkg. (10)	C	6	1-2	If desired, split sausages in half lengthwise; cut into 5- to 6-inch pieces.



OPERATING THE SELF-CLEANING OVEN

Normal Cleaning Time: 3 hours

Before a Clean Cycle

The range must be completely cool in order to set the self-clean cycle.

1. Remove the broiler pan, broiler rack, all cookware and any aluminum foil from the oven—they can't withstand the high cleaning temperatures.

NOTE: The oven shelves may be cleaned in the self-cleaning oven. However, they will darken, lose their luster and become hard to slide.

2. Wipe up heavy soil on the oven bottom. If you use soap, rinse thoroughly before self-cleaning to prevent staining.

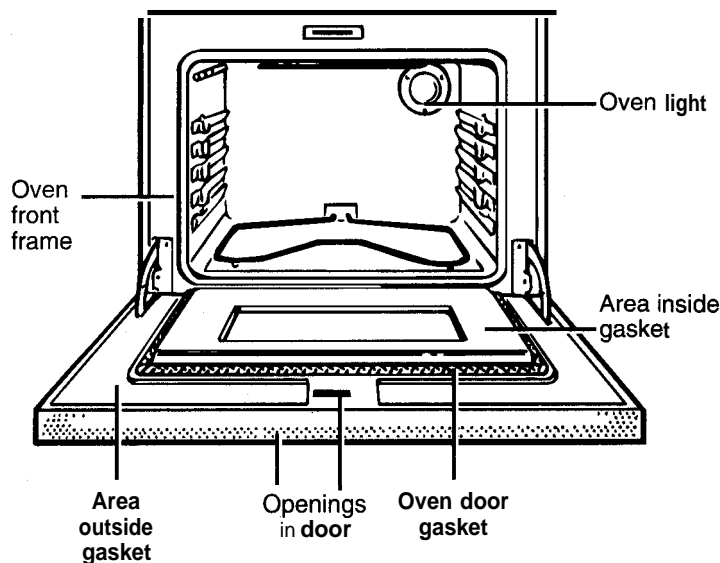

3. Clean spatters or soil on the oven front frame and the oven door outside the gasket with a dampened cloth. The oven front frame and the oven door outside the gasket do not get cleaned by the self-clean cycle. On these areas, use detergent and hot water or a soap-filled steel wool pad. Rinse well with a vinegar and water solution. This will help prevent a brown residue from forming when the oven is heated. Buff these areas with a dry cloth. Do not clean the gasket.

Clean the top, sides and outside front of the oven door with soap and water. Do not use abrasives or oven cleaners.

Make sure the oven light bulb cover is in place.

Do not rub or clean the door **gasket**—the fiberglass material of the gasket has an extremely low resistance to abrasion. An intact and well-fitting oven door gasket is essential for energy-efficient oven operation and good baking results. If you notice the gasket becoming worn, frayed or damaged in any way or if it has become displaced on the door, you should have it replaced.

Do not let water run down through openings in the top of the door. To help prevent water from getting in these slots when cleaning, open the door as far as it will go.

4. Close the oven door and make sure the oven light is off. If the oven light is not turned off, the life of the bulb will be shortened or it may burn out immediately. The door latches automatically after the clean cycle is set.

Do not use commercial oven cleaners or oven protectors in or near the self-cleaning oven. A combination of any of these products plus the high clean-cycle temperature may damage the porcelain finish of the oven.



How to Set Oven for Cleaning

Quick Reminder:

1. Press the CLEAN pad.
2. Press the INCREASE or DECREASE pad until the desired Clean Time appears.

If the oven is too hot and you start to set a clean cycle, the word "OFF" will appear in the display. Allow additional time for cooling before you try to set the cycle.

1. Follow the steps in the Before a Clean Cycle section.



2. After closing the door, press the CLEAN pad.



3. Press the INCREASE or DECREASE pad until the desired Clean Time is displayed.

Clean Time is normally 3 hours. You can change the Clean Time to anytime between 2 and 4 hours, depending on the amount of soil in your oven.

The self-clean cycle will automatically begin after "CLEAN" is displayed and the time for the clean cycle is set. The words "ON" and "LOCK" will appear in the display when the door automatically locks. It will not be possible to open the oven door until the temperature drops below the lock temperature and the LOCK light goes off.

4. When the LOCK light is off, open the door.

NOTE:



- You can Find out when the clean cycle will be finished by pressing the STOP TIME pad.

The word "door" will be displayed, the word "LOCK" will flash and oven control will signal if you set the clean cycle and forget to close the oven door.

- A fan may automatically turn on and off to cool internal parts. This is normal and the fan may continue to run after the oven is turned off.

To Stop a Clean Cycle



1. Press the CLEAR/OFF pad.

2. When the LOCK light goes off and the oven has cooled below the locking temperature, open the door.

(continued next page)



OPERATING THE SELF-CLEANING OVEN

(continued)

After Self-Cleaning

You may notice some white ash in the oven. Just wipe it up with a damp cloth after the oven cools.

If white spots remain, remove them with a soap-filled steel wool pad. Be sure to rinse thoroughly with a vinegar and water mixture. These deposits are usually a salt residue that cannot be removed by the clean cycle.

If the oven is not clean after one clean cycle, repeat the cycle.

If the shelves have become hard to slide, wipe the shelf supports with cooking oil.

NOTE: No functions can be programmed before the door automatically unlocks.

How to Set Delay Start of Cleaning

Quick Reminder:

1. Press the CLEAN pad.
2. Press the INCREASE or DECREASE pad until the desired Clean Time appears.
3. Press the STOP TIME pad.
4. Press the INCREASE or DECREASE pad until the desired Stop Time appears in the display.

Delay Start is setting the oven timer to start the clean cycle automatically at a later time than the present time of day.

NOTE: Before beginning, make sure the oven clock shows the correct time of day.

1. Follow the steps in the Before a Clean Cycle section.



2. press the CLEAN pad.

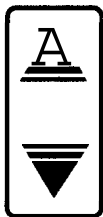

3. Press the INCREASE or DECREASE pad to enter Clean Time.



4. Press the STOP TIME pad. "STOP TIME" and the earliest Stop Time you can set will appear in the display.

The earliest Stop Time will be the Clean Time selected plus the time of day. **For example:** If the Clean Time is three hours and the time of day is 6:00, the Stop Time that appears in the display will be 9:00.

5. Press the INCREASE pad to change the Stop Time to a later time of day if desired. For example: If you set Stop Time at 11:00, oven will start clean cycle at 8:00 and end at 11:00. The door latches automatically.

The self-clean cycle will automatically begin after "CLEAN" is displayed and the time for clean cycle is set. The words "ON" and "LOCK" will appear in the display when the door automatically locks. It will not be possible to open the oven door until the temperature drops below the lock temperature and the LOCK light goes off.

6. When the LOCK light is off, open the door.

NOTE:

- During a delayed self-clean operation you can find out when the oven is set to turn on by pressing and holding the CLEAN pad for 3 seconds.
- A fan may automatically turn on and off to cool internal parts. This is normal and the fan may continue to run after the oven is turned off.



Questions and Answers

Q. If my oven clock is not set to the correct time of day, can I still self-clean my oven?

A. If the clock is not set to the correct time of day you will not be able to set a delay clean to end at a specific time.

Q. Can I use commercial oven cleaners on any part of my self-cleaning oven?

A. No cleaners or coatings should be used around any part of this oven. If you do use them and do not thoroughly rinse the oven with water, wiping it absolutely clean afterwards, the residue can scar the oven surface and damage metal parts the next time the oven is automatically cleaned.

Q. What should I do if excessive smoking occurs during cleaning?

A. This is caused by excessive soil. Turn the oven off. Open the windows to rid the room of smoke. Wait until the oven has cooled and the word "LOCK" is off in the display. Wipe up the excess soil and reset the clean cycle.

Q. Is the "crackling" or "popping" sound I hear during cleaning normal?

A. Yes. This is the sound of the metal heating and cooling during both the cooking and cleaning functions.

Q. Should there be any odor during the cleaning?

A. Yes, there will be an odor during the first few cleanings. Failure to wipe out excessive soil might also cause a strong odor when cleaning.

Q. What causes the hair-like lines on the enameled surface of my oven?

A. This is a normal condition, resulting from heating and cooling during cleaning. These lines do not affect how your oven performs.

Q. Why do I have ash left in my oven after cleaning?

A. Some types of soil will leave a deposit which is ash. It can be removed with a damp sponge or cloth.

Q. My oven shelves do not slide easily. What is the matter?

A. After many cleanings, oven shelves may become so clean they do not slide easily. To make shelves slide more easily, after each self-cleaning function dampen fingers with a small amount of cooking oil and rub lightly over sides of shelf where they contact shelf supports.

Q. My oven shelves have become gray after the self-clean cycle. Is this normal?

A. Yes. After the self-clean cycle, the shelves may lose some luster and change to a deep gray color.

Q. Can I cook food on the cooktop while the oven is self-cleaning?

A. Yes. While the oven is self-cleaning, you can use the cooktop just as you normally do.

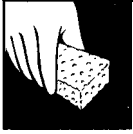

CARE AND CLEANING

Proper care and cleaning are important so your range will give you efficient and satisfactory service. Follow these directions carefully in caring for it to help assure safe and proper maintenance.

BE SURE ELECTRICAL POWER IS OFF BEFORE CLEANING ANY PART OF THE RANGE.

Painted Surfaces

Painted surfaces include the outside oven door, sides, control panel and drawer front. Clean these with soap and water or a vinegar and water solution. **Do not use commercial oven cleaners, cleansing powders, steel wool or harsh abrasives on any painted surface.**

Glass Window

To clean the outside of the oven window, use a glass cleaner. Rinse and polish with a dry cloth. Do not allow the water or cleaner to run down inside the openings in the glass or the openings in the top of the oven door while cleaning.

Control Panel and Knobs

It's a good idea to wipe the control panel after each use. Clean with mild soap and water or vinegar and water, rinse with clean water and polish dry with a soft cloth.

Do not use abrasive cleansers, strong liquid cleansers, plastic scouring pads or oven cleaners on the control panel—they will damage the finish. A 50/50 solution of vinegar and hot water works well.

The control knobs may be removed for easier cleaning. Before removing the knobs for cleaning, please note that the knobs on the left side and the knobs on the right side are in the proper OFF position. When replacing the knobs, check the OFF position to insure proper alignment.

To remove a knob, pull it straight off the stem. If a knob is difficult to remove, place a thin cloth (like a handkerchief,) or a piece of string under and around the knob edge and pull up.

Wash the knobs in soap and water but do not soak. Avoid getting water down into the knob stem holes. To replace a knob, locate the groove in each side of the knob stem. One of the grooves contains a spring clip and the other groove is clear. Locate the molded rib inside the knob. Fit the molded rib into the clear groove on the knob stem.

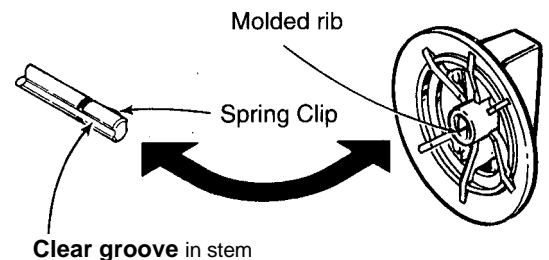

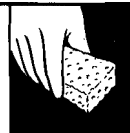

Surface Units and Drip Pans

To clean the surface units, turn the control to the highest setting for a minute. The coils will burn off any soil.

CAUTION

- **Be sure all the controls are turned to OFF and the surface units are cool before attempting to remove them.**
- Do not immerse the surface units in liquids of any kind.
- Do not clean the surface units in a dishwasher.
- Do not bend the surface unit plug terminals.
- Do not attempt to clean, adjust or in any way repair the plug-in receptacle.

To remove a surface unit:

To remove the drip pans for cleaning, the surface units must be removed first.

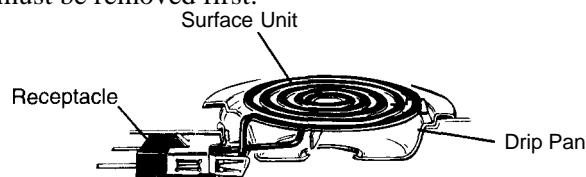

Lift the surface unit about 1 inch above the drip pan—red pull it out.

Do not lift the surface unit more than 1 inch. If you do, it may not lie flat on the drip pan when you plug it back in.

Repeated lifting of the surface unit more than 1 inch above the drip pan can permanently damage the receptacle.

To replace a surface unit:

- Replace the drip pan into the recess in the cooktop. Make sure opening in the pan lines up with the receptacle.
- Insert the terminals of the surface unit through the opening in the drip pan and into the receptacle.
- Guide the surface unit into place so it rests evenly.

Drip Pans

Remove the surface units. Then lift out the drip pans. For best results, clean the drip pans by hand. Place them in a covered container (or a plastic bag) with 1/4 cup ammonia to loosen the soil. Then scrub with a soap filled scouring pad if necessary. Rinse with clean water and polish with a clean soft cloth.

The drip pans may also be cleaned in the dishwasher. Black drip pans (on some models) may be cleaned in a self-cleaning oven after they have been thoroughly rinsed. However, self-cleaning them may cause them to lose their original luster and shine.

Clean the area under the drip pans often.

Built-up soil, especially grease, may catch on fire.

Do not cover drip pans with foil. Using foil so close to the receptacle could cause shock, fire or damage to the range.

Lift-Up Cooktop

Clean the area under the cooktop often. Built-up soil, especially grease, may catch fire.

To make cleaning easier, the entire cooktop may be lifted up and supported in the up position.

Be sure all the surface units are turned off before raising the cooktop. The surface units and drip pans do not need to be removed, however, you may remove one to make raising the cooktop easier. Dual support rods will hold the cooktop up while you clean underneath it.

After cleaning under the cooktop with hot, soapy water and a clean cloth, lower the cooktop. Be careful not to pinch your fingers.

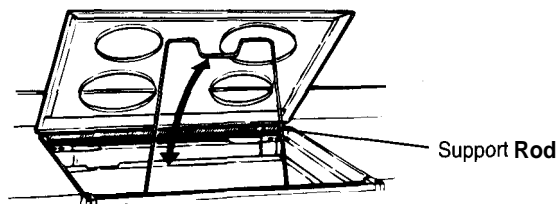

Oven Vent

The oven is vented through an opening under the right rear surface unit. Never cover the opening with aluminum foil or any other material. This would prevent the oven vent from working properly.

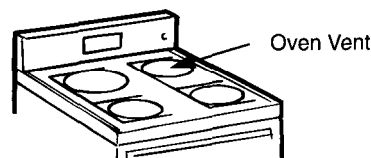

(continued next page)

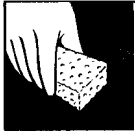

CARE AND CLEANING

(continued)

Lift-Off Oven Door

The oven door is removable, but it is heavy. You may need help removing and replacing the door. Do not lift the door by the handle. This can cause the glass to break or can cause damage to the door.

To remove the door, open it a few inches to the special stop position that will hold the door open. Grasp firmly on each side and lift the door straight up and off the hinges.

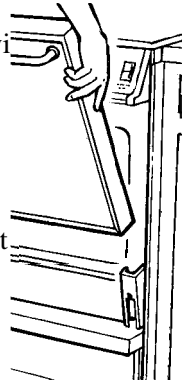

NOTE:

- Be careful not to place hands between the hinge and the oven door frame as the hinge could snap back and pinch fingers.
- While working in the oven area, cover the hinges with towels or empty paper towel rolls to prevent pinched fingers and chipping the porcelain enamel on the frame.

To replace the door, make sure the hinges are in the special stop position. Position the slots in the bottom of the door squarely over the hinges. Then lower the door slowly and evenly over both hinges at the same time. If hinges snap back against the oven frame, pull them back out.

TO CLEAN THE DOOR:

Inside of the door:

- Because the area inside the gasket is cleaned during the self clean cycle, you do not need to clean this by hand. Any soap left on the liner causes additional stains when the oven is heated.
- The area outside the gasket can be cleaned with a scouring pad.

- Do not rub or clean the door gasket—the fiberglass material of the gasket has an extremely low resistance to abrasion. An intact and well-fitting oven door gasket is essential for energy-efficient oven operation and good baking results. If you notice the gasket becoming worn, frayed or damaged in any way or if it has become displaced on the door, you should have it replaced.

NOTE: The gasket is designed with a gap at the bottom to allow for proper air circulation.

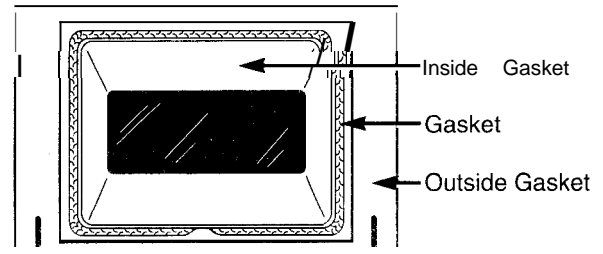

Outside of the door:

- Use soap and water to thoroughly clean the top, sides and front of the oven door. DO NOT let water run down through openings in the top of the door. — Rinse well. You may also use a glass cleaner to clean the glass on the outside of the door.
- Spillage of marinades, fruit juices, tomato sauces and basting materials containing acids may cause discoloration and should be wiped up immediately. When surface is cool, clean and rinse.
- Do not use oven cleaners, cleansing powders or harsh abrasives on the outside of the door.

Removable Storage Drawer

The storage drawer is a good place to store cookware and bakeware. Do not store plastics and flammable material in the drawer.

Do not overload the storage drawer. If the drawer is too heavy, it may slip off the track when opened. To open the drawer, grasp the center of the handle and pull straight out.

The storage drawer may be removed for cleaning under the range.

To remove: Pull the drawer straight out and lift over the guide stops.

To replace: Lift over the guide stops and slide the drawer into place.

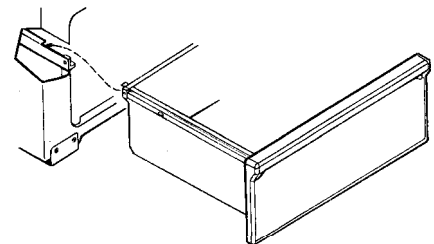

To clean both the inside and the outside:

Wipe with soap and water. Rinse well.

Do not use cleansing powders or harsh abrasives which may scratch the surface.

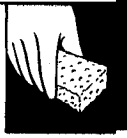

Porcelain Enamel Cooktop

The porcelain enamel finish is sturdy but breakable if misused.

This finish is acid-resistant. However, any acid foods spilled (such as fruit juices, tomato or vinegar) should not be permitted to remain on the finish.

If acids spill on the cooktop while it is hot, use a dry paper towel or cloth to wipe it up right away. When the surface has cooled, wash with soap and water. Rinse well.

For other spills such as fat smatterings, wash with soap and water or cleansing powders after the surface has cooled. Rinse well. Polish with a dry cloth.

Oven Light Bulb

The light bulb is located on the back wall of the oven. Before replacing the bulb, disconnect electrical power to the range at the main fuse or circuit breaker panel or unplug the range from the electrical outlet. Let the bulb cool completely before removing it. For your safety, do not touch a hot bulb with a damp cloth. If you do, the bulb will break.

To remove: Unscrew the cover and remove the bulb.

To replace: Put in a new 40-watt appliance bulb.

NOTE:

- A 40-watt appliance bulb is smaller than a standard 40-watt household bulb.
- Install and tighten the cover.
- Reconnect electrical power to the range.

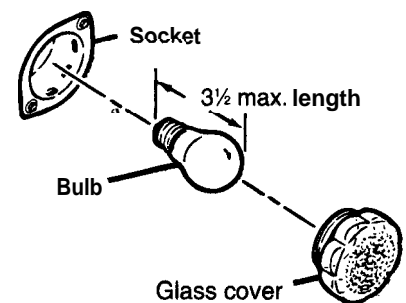

Oven Shelves

Clean the shelves with  an abrasive cleanser or steel wool. After cleaning, rinse the shelves with clean water and dry with a clean cloth.

NOTE: The oven shelves may also be cleaned in the self-cleaning oven. However, the shelves may darken in color, lose their luster and become hard to slide if cleaned during the self-cleaning cycle. Wipe the shelf supports with cooking oil after self cleaning to make the shelves slide more easily.

Broiler Pan and Rack

After broiling,  remove the broiler pan and rack from the oven. Remove the rack from the pan.

Carefully pour the grease from the pan into a proper container. Wash and rinse the broiler pan and rack in hot water with a soap-filled or plastic scouring pad.

- **If food has burned on,** sprinkle the rack with detergent while hot and cover with wet paper towels or a dishcloth. Soaking the pan will remove burned-on foods.

The broiler pan and rack may be cleaned with a commercial oven cleaner.

Do not store a soiled pan and rack anywhere in the range.

Both the broiler pan and rack can also be cleaned in the dishwasher.

Do not clean the broiler pan or rack in the self-cleaning oven.



ANTI-TIP DEVICE

1. Before placing range in the counter, notice the location of the stability bracket which is already attached to the back of the range. This location should work for most installations. However, it may be more convenient to hook the stability chain to the unit when the stability bracket is attached to the upper set of holes in the back of the range. See Fig. A. The upper level set of holes are intended for use with a backsplash kit. If the backsplash is not being used, make sure that there are no structural supports for the countertop which will interfere with the stability bracket when located in the upper set of holes.

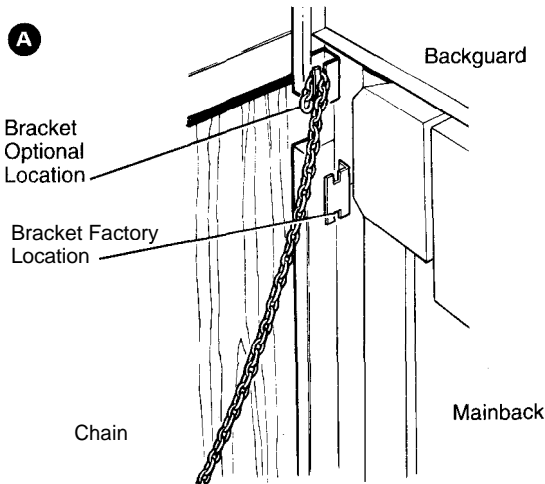

2. Fasten one end of the stability chain to the floor or wall with the long screw and washer supplied. See Fig. B. Make certain the screw is going into the wall plate at the base of the wall or one of the studs in the base of the wall. See Fig. C. Whether you attach the chain to the wall or floor, be certain that the screw is in at least 3/4 inch thickness of wood other than baseboard and that there are no electrical wires or plumbing in the area which the screw could penetrate. Attach the stability chain in a location which will allow the chain to be in line with the bracket side to aide as much as possible when attached to the unit. Test to see if the chain is securely fastened by tugging on the chain.

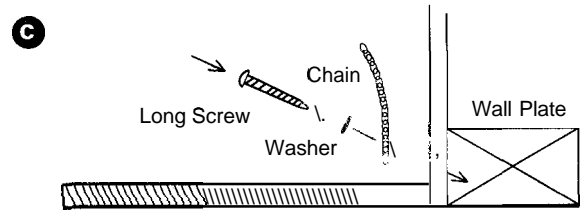
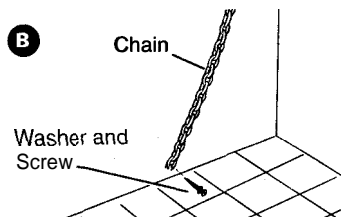

3. Temporarily attach the loose end of the chain to the rear of the countertop with the tape from the packaging. See Fig. D.
4. Place the range in the counter cutout leaving just enough room between the back of the range and the wall to reach the stability bracket.
5. Hook the loose end of the chain onto the bracket by slipping the nearest link of the chain into the slot in the bracket. See Fig. A and make sure the chain is pulled as tight as possible and that there is no excess slack in the chain after the chain is attached to the bracket.

A CAUTION: Excessive slack in the chain could allow the range to tip over.

6. Slide the range all the way back into the counter. Once the range is pushed back in place, there will be a small amount of slack in the chain. This is normal.

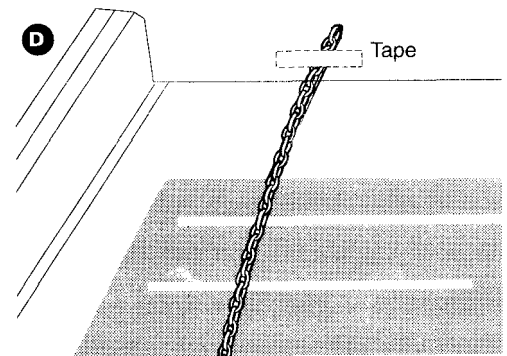

NOTE:

- If attaching to masonry, you can buy suitable screws and anchors at hardware stores. Use a masonry drill to drill the required holes.
- If range is removed for cleaning or any other reason, make sure chain is reattached.

QUESTIONS? USE THIS PROBLEM SOLVER



PROBLEM	POSSIBLE CAUSE
"F—" AND A NUMBER FLASH IN THE DISPLAY	<ul style="list-style-type: none"> • This is function error code. Press the CLEAR/OFF pad. Allow the oven to cool one hour. Place the oven back into operation. If function error occurs again, disconnect power to the oven and call for service.
OVEN WILL NOT WORK	<ul style="list-style-type: none"> • The plug on the range is not completely inserted in the electrical outlet. • The circuit breaker in your house has been tripped, or a fuse has been blown. • The oven controls are not properly set.
OVEN LIGHT DOES NOT WORK	<ul style="list-style-type: none"> * The light bulb is loose or defective. Tighten or replace. • The switch operating the oven light is broken. Call for service.
FOOD DOES NOT BROIL PROPERLY	<ul style="list-style-type: none"> • Oven controls not set properly. See the Broiling section. • Door not left open to the broil stop position as recommended. • Improper shelf position being used. See the Broiling Guide. • Food is being cooked on a hot pan. • Cookware is not suited for broiling. • Low voltage. See the Broiling section. • Aluminum foil used on the broiler pan and rack has not been fitted properly and slit as recommended.
FOOD DOES NOT ROAST OR BAKE PROPERLY	<ul style="list-style-type: none"> • Oven controls not set properly. See the Baking or Roasting section. • Shelf position is incorrect. See the Roasting or Baking section. • Incorrect cookware or cookware of improper size is being used. • Oven thermostat needs adjustment. See the Adjust the Oven Thermostat—<i>Do It Yourself</i> section.
CLOCK AND MINUTE/SECOND TIMER DO NOT WORK	<ul style="list-style-type: none"> • Make sure electrical plug is plugged into a live, properly grounded power outlet. • Check for a power outage. • See the Oven Control, Clock and Timer section.
SURFACE UNITS NOT FUNCTIONING PROPERLY	<ul style="list-style-type: none"> * Surface units are not plugged in solidly. • Surface unit controls are not properly set.
OVEN WILL NOT SELF-CLEAN	<ul style="list-style-type: none"> • Oven temperature is too high to set self-clean operation. Allow the range to cool to room temperature and reset the controls.
DOOR WILL NOT OPEN AFTER SELF-CLEAN CYCLE	<ul style="list-style-type: none"> • When the temperature has fallen below the locking temperature door can be opened.
OVEN NOT CLEAN AFTER CLEAN CYCLE	<ul style="list-style-type: none"> • Oven controls not set properly. See the Operating the Self-Cleaning Oven section. • Heavily soiled ovens require 3½- to 4-hour Clean Time. • Heavy spillovers should be cleaned up before starting the clean cycle.
"door" APPEARS IN THE DISPLAY	<ul style="list-style-type: none"> * Oven door is not closed after the self-clean cycle is selected. • Door is still locked and you are trying to enter an oven cooking operation.

(continued next page)



THE PROBLEM SOLVER

(continued)

PROBLEM	POSSIBLE CAUSE
OVEN TEMPERATURE TOO HOT OR TOO COLD	• Oven thermostat needs adjustment. See the <i>Adjust the Oven Thermostat—Do It Yourself</i> section.
“BURNING” OR “OILY” ODOR EMITTING FROM OVEN WHEN TURNED ON	• This is normal in a new oven and will disappear in time.
STRONG ODOR	• An odor from the insulation around the inside of the oven is normal for the first few times the oven is used. This is temporary.

If you need more help... call, toll free:

GE Answer Center®

800.626.2000

consumer information service

We'll Be There

With the purchase of your new GE appliance, receive the assurance that if you ever need information or assistance from GE, we'll be there. All you have to do is call—toll-free!

In-Home Repair Service **800-GE-CARES (800-432-2737)**

A GE consumer service professional will provide expert repair service, scheduled at a time that's convenient for you. Many GE Consumer Service company-operated locations offer you service today or tomorrow, or at your convenience (7:00 a.m. to 7:00 p.m. weekdays, 9:00 a.m. to 2:00 p.m. Saturdays). Our factory-trained technicians know your appliance inside and out—so most repairs can be handled in just one visit.

GE Answer Center® **80116262000**

Whatever your question about any GE major appliance, GE Answer Center® information service is available to help. Your call—and your question—will be answered promptly and courteously. And you can call any time. GE Answer Center® service is open 24 hours a day, 7 days a week.

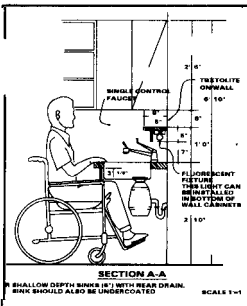

For Customers With Special Needs... **80116262000**

Upon request, GE will provide Braille controls for a variety of GE appliances, and a brochure to assist in planning a barrier-free kitchen for persons with limited mobility. To obtain these items, free of charge, call 800.626.2000.

Consumers with impaired hearing or speech who have access to a TDD or a conventional teletypewriter may call 800-TDD-GEAC (800-833-4322) to request information or service.

Service Contracts **800-626-2224**

-You can have the secure feeling that GE Consumer Service will still be there after your warranty expires. Purchase a GE contract while your warranty is still in effect and you'll receive a substantial discount. With a multiple-year contract, you're assured of future service at today's prices.

Parts and Accessories **800-626-2002**

Individuals qualified to service their own appliances can have needed parts or accessories sent directly to their home. The GE parts system provides access to over 47,000 parts... and all GE Genuine Renewal Parts are fully warranted. VISA, MasterCard and Discover cards are accepted.

User maintenance instructions contained in this booklet cover procedures intended to be performed by any user. Other servicing generally should be referred to qualified service personnel. Caution must be exercised, since improper servicing may cause unsafe operation.

YOUR GE ELECTRIC RANGE WARRANTY

Staple sales slip or **cancelled** check here. Proof of original purchase date is needed to obtain service under warranty.

WHAT IS COVERED

FULL ONE-YEAR WARRANTY

For one year from date of original purchase, we will provide, free of charge, parts and service labor in your home to repair or replace **any part of the range** that fails because of a manufacturing defect.

This warranty is extended to the original purchaser and any succeeding owner for products purchased for ordinary home use in the 48 mainland states, Hawaii and Washington, D.C. In Alaska the warranty is the same except that it is LIMITED because you must pay to ship the product to the service shop or for the service technician's travel costs to your home.

All warranty service will be provided by our Factory Service Centers or by our authorized Customer Care® servicers during normal working hours.

Should your appliance need service, during warranty period or beyond, call 800-GE-CARES (800-432-2737).

WHAT IS NOT COVERED

- Service trips to your home to teach you how to use the product.

Read your Use and Care material.

If you then have any questions about operating the product, please contact your dealer or our Consumer Affairs office at the address below, or call, toll free: GE Answer Center@ 800.626.2000 consumer information service

- Improper installation.

If you have an installation problem, contact your dealer or installer. You are responsible for providing adequate electrical, gas, exhausting and other connecting facilities as described in the Installation Instructions provided with the product.

- Replacement of house fuses or resetting of circuit breakers.
- Failure of the product if it is used for other than its intended purpose or used commercially.
- Damage to product caused by accident, fire, floods or acts of God.

WARRANTOR IS NOT RESPONSIBLE FOR CONSEQUENTIAL DAMAGES.

Some states do not **allow** the exclusion or limitation of incidental or consequential damages, so the above limitation or exclusion may not apply to you. This warranty gives you specific legal rights, and you may also have other rights which vary from state to state. To know what your legal rights are in your state, consult your local or state consumer affairs office or your state's Attorney General.

Warrantor: General Electric Company

**If further help is needed concerning this warranty, write:
Manager—Consumer Affairs, GE Appliances, Louisville, KY 40225**



Recycled Paper

Part No. 164 D2966P044

Pub No. 49-8517

3-94 CG

JSP:
JSP:

Printed in LaFayette, (