

# JENN-AIR®

## 30" (76.2 CM) AND 45" (114.3 CM) ELECTRIC DOWNDRAFT COOKTOP INSTALLATION INSTRUCTIONS INSTRUCTIONS D'INSTALLATION DE LA TABLE DE CUISSON ÉLECTRIQUE AVEC ASPIRATION PAR LE BAS DE 30" (76,2 CM) ET 45" (114,3 CM)

### Table of Contents/Table des matières

<b>COOKTOP SAFETY</b> .....	1	<b>SÉCURITÉ DE LA TABLE DE CUISSON</b> .....	13
<b>INSTALLATION REQUIREMENTS</b> .....	2	<b>EXIGENCES D'INSTALLATION</b> .....	13
Tools and Parts .....	2	Outillage et pièces.....	13
Location Requirements .....	2	Exigences d'emplacement.....	13
Venting Requirements .....	4	Exigences concernant l'évacuation .....	16
Venting Methods .....	5	Méthodes d'évacuation.....	17
Electrical Requirements .....	7	Spécifications électriques .....	19
<b>INSTALLATION INSTRUCTIONS</b> .....	8	<b>INSTRUCTIONS D'INSTALLATION</b> .....	20
Prepare Cooktop .....	8	Préparation de la table de cuisson .....	20
Rotate Blower - Optional.....	9	Rotation du ventilateur - Facultative.....	20
Install Cooktop .....	10	Installation de la table de cuisson.....	21
Make Electrical Connection .....	10	Raccordement électrique.....	21
Complete Installation.....	11	Achever l'installation .....	23

## COOKTOP SAFETY

### Your safety and the safety of others are very important.

We have provided many important safety messages in this manual and on your appliance. Always read and obey all safety messages.



This is the safety alert symbol.

This symbol alerts you to potential hazards that can kill or hurt you and others.

All safety messages will follow the safety alert symbol and either the word "DANGER" or "WARNING."

These words mean:

**⚠ DANGER**

**You can be killed or seriously injured if you don't immediately follow instructions.**

**⚠ WARNING**

**You can be killed or seriously injured if you don't follow instructions.**

All safety messages will tell you what the potential hazard is, tell you how to reduce the chance of injury, and tell you what can happen if the instructions are not followed.

### IMPORTANT:

Save for local electrical inspector's use.

### IMPORTANT :

À conserver pour consultation par l'inspecteur local des installations électriques.

# INSTALLATION REQUIREMENTS

## Tools and Parts

Gather the required tools and parts before starting installation. Read and follow the instructions provided with any tools listed here.

### Tools needed

- Tape measure
- Flat-blade screwdriver
- Phillips head screwdriver
- Drill
- Level
- 6" socket extension
- Marker or pencil
- Pliers
- ¼" drill bit
- Jigsaw
- Ratchet with ⅜" socket

### Parts supplied

- Vent grille
- Grease filter
- Grill cartridge
- Grease container(s)
- Hold-down straps (4)
- Clamping screws (4)

### Parts needed

- A UL listed or CSA approved strain relief for 7/8" (2.2 cm) knockout.
- A UL listed or CSA approved conduit connector for ½" (1.3 cm) trade-size metal-clad conduit
- UL listed wire connectors
- Metal ducting
- Jenn-Air wall cap
  - Jenn-Air® 6" (15.2 cm) Round Surface Wall Cap Damper  
Order Part Number A406
  - Jenn-Air® 3¼" x 10" (8.3 x 25.4 cm) Surface Wall Cap Damper  
Order Part Number A403
- To order, see the "Assistance or Service" section of the Use and Care Guide.
- Vent clamps

Check local codes. Check existing electrical supply. See "Electrical Requirements" section.

It is recommended that all electrical connections be made by a licensed, qualified electrical installer.

## Location Requirements

**IMPORTANT:** Observe all governing codes and ordinances. When installing cooktop, use minimum dimensions given.

- To eliminate the risk of burns or fire by reaching over the heated surface units, cabinet storage space located above the surface units should be avoided. If cabinet storage is to be provided, the risk can be reduced by installing a range hood that projects horizontally a minimum of 5" (12.7 cm) beyond the bottom of the cabinets.

- Use the countertop opening dimensions that are given with these Installation Instructions. Given dimensions are minimum clearances and provide 0" (0 cm) clearance.
- Grounded electrical supply is required. See "Electrical Requirements" section.
- If cabinet has drawers, drawers will need to be removed and drawer fronts installed on front of cabinet.

**IMPORTANT:** An under-counter built-in oven cannot be installed under this product.

## Product Dimensions

### 30" (76.2 cm) Cooktop

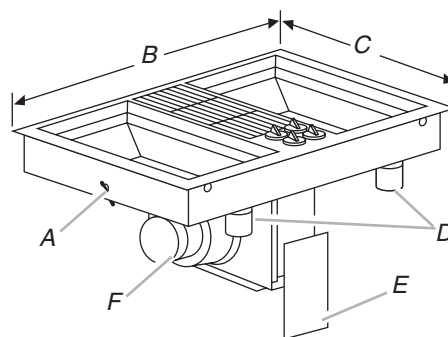

- A. Tie down bolt (on each side of cooktop)
- B. 30" (76.2 cm)
- C. 21¾" (55.3 cm)
- D. Grease container(s)
- E. Wiring box cover
- F. Blower

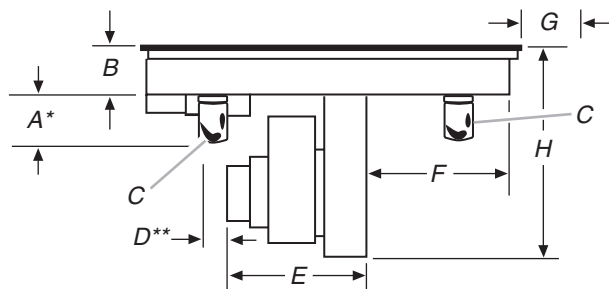

- A. 6¼" (15.9 cm)
- B. 3½" (8.9 cm)
- C. Grease container(s)
- D. 2" (5.1 cm)
- E. 13¾" (34.9 cm)
- F. 11¹³⁄₁₆" (30.0 cm)
- G. 4" (10.2 cm)
- H. 13¹³⁄₁₆" (35.1 cm)

\*A minimum clearance of 6¼" (15.9 cm) is recommended for removal of the grease container(s). Installed dimension for the grease container(s) is 5½" (14.0 cm).

\*\*A minimum clearance of 2" (5.1 cm) is recommended between the motor/blower and cabinet for proper cooling.

## 45" (114.3 cm) Cooktop

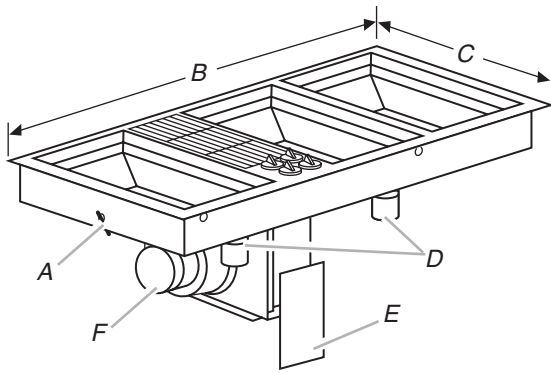

- A. Tie down bolt (on each side of cookop)
- B. 45" (114.3 cm)
- C. 21 $\frac{3}{4}$ " (55.3 cm)
- D. Grease containers
- E. Wiring box cover
- F. Blower

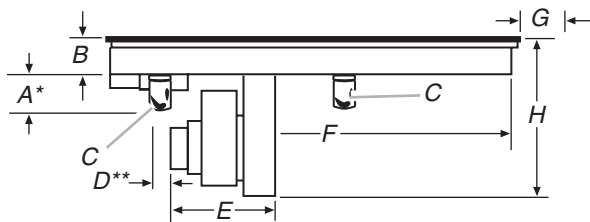

- A. 6 $\frac{1}{4}$ " (15.9 cm)
- B. 3 $\frac{1}{2}$ " (8.9 cm)
- C. Grease containers
- D. 2" (5.1 cm)
- E. 13 $\frac{3}{4}$ " (34.9 cm)
- F. 26 $\frac{3}{4}$ " (68.0 cm)
- G. 4" (10.2 cm)
- H. 13 $\frac{1}{16}$ " (35.1 cm)

\*A minimum clearance of 6 $\frac{1}{4}$ " (15.9 cm) is recommended for removal of the grease containers. Installed dimension for the grease containers is 5 $\frac{1}{2}$ " (14.0 cm).

\*\*A minimum clearance of 2" (5.1 cm) is recommended between the motor/blower and cabinet for proper cooling.

## Cabinet Dimensions

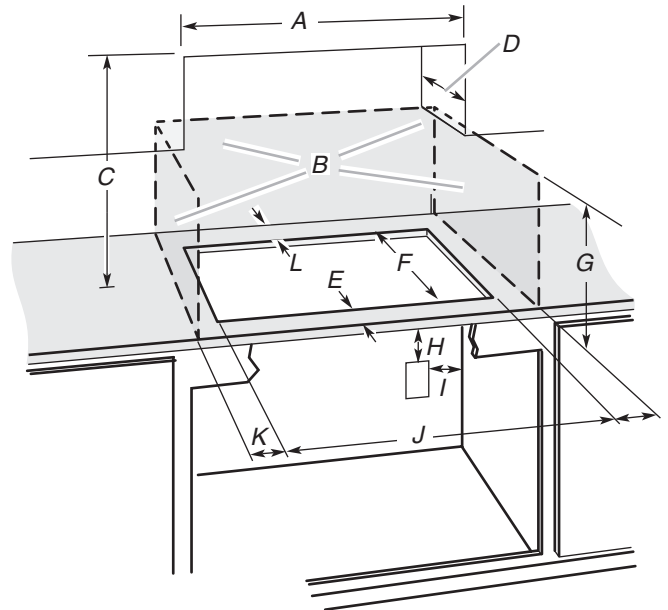

- A. 30" (76.2 cm) on 30" (76.2 cm) models  
45" (114.3 cm) on 45" (114.3 cm) models
- B. Combustible area above countertop (shown by dashed box above)
- C. 30" (76.2 cm) minimum clearance between top of cooktop platform and bottom of uncovered wood or metal cabinet (24" [61 cm] minimum clearance if bottom of wood or metal cabinet is covered by not less than  $\frac{1}{4}$ " [0.6 cm] flame retardant millboard covered with not less than No. 28 MSG sheet steel, 0.015" [0.04 cm] stainless steel, or 0.024" [0.06 cm] aluminum or 0.020" [0.05 cm] copper)
- D. 13" (33 cm) recommended upper cabinet depth
- E. 1 $\frac{7}{8}$ " (4.8 cm) min.
- F. 21" (53.3 cm)
- G. 18" (45.7 cm) minimum clearance from upper cabinet to countertop within minimum horizontal clearances to cooktop
- H. Junction box or outlet; 12" (30.5 cm) minimum from bottom of countertop
- I. Junction box or outlet; 10" (25.4 cm) from right-hand side of cabinet
- J. 29 $\frac{1}{16}$ " (73.9 cm) on 30" (76.2 cm) models  
43 $\frac{1}{4}$ " (109.9 cm) on 45" (114.3 cm) models
- K. 2 $\frac{1}{2}$ " (6.4 cm) minimum distance to nearest left and right side combustible surface above cooktop
- L. 1 $\frac{1}{2}$ " (3.8 cm) minimum clearance between back wall and countertop

**NOTES:** After making the countertop cutout, some installations may require notching down the base cabinet side walls to clear the cooktop base. To avoid this modification, use a base cabinet with sidewalls wider than the cutout.

- Where possible, a 6" (15.2 cm) clearance is recommended for motor blower service. A minimum clearance of 1" (2.5 cm) is recommended to the sidewalls and a ¾" (1.9 cm) clearance is recommended to the rear wall.
- A minimum clearance of 2" (5.1 cm) is recommended between the motor/blower and cabinet for proper cooling.
- A minimum clearance of 6¼" (15.9 cm) is recommended for removal of the grease container(s). Installed dimension for the grease containers is 5½" (14.0 cm).
- For grills installed near a sidewall, a minimum clearance of 6" (15.2 cm) is recommended between the cooktop and sidewall for maximum performance.

## Venting Requirements

- Do not terminate the vent system in an attic or other enclosed area.
- Use a Jenn-Air® vent cap.
- Vent system must terminate to the outside.
- Use only a 6" (15.2 cm) round metal vent. Rigid metal vent is recommended. For best performance, do not use plastic or metal foil vent.
- Before making cutouts, make sure there is proper clearance within the wall or floor for the exhaust vent.
- Do not cut a joist or stud unless absolutely necessary. If a joist or stud must be cut, then a supporting frame must be constructed.
- The size of the vent should be uniform.
- The vent system must have a damper. If roof or wall cap has a damper, do not use damper supplied with the range hood.
- Use only a 6" (15.2 cm) round metal vent or a 3¼" x 10" (8.3 x 25.4 cm) rectangular metal vent except for as follows:
  - For electric models, 5" (12.7 cm) diameter round metal vent may be used for venting straight out the back of the cooktop and directly through the wall for a duct length of 10 ft (3.0 m) feet or less.
  - For gas models, 5" (12.7 cm) diameter round metal vent must be used if the duct length is 10 ft (3.0 m) feet or less.
- Do not use 5" (12.7 cm) elbows except in a 5" (12.7 cm) system. Instead, use a 5" (12.7 cm) to 6" (15.2 cm) elbow or a 5" (12.7 cm) to 3¼" x 10" (8.3 x 25.4 cm) elbow transition.
- Use vent clamps to seal all joints in the vent system.
- Use caulking to seal exterior wall or roof opening around the cap.
- Determine which venting method is best for your application.

### For Best Performance:

- Use 26-gauge minimum galvanized or 25-gauge minimum aluminum metal vent. Poor quality pipe fittings can reduce airflow. Flexible metal vent is not recommended.
- NOTE:** Local codes may require a heavier gauge material.
- Metal duct may be reduced to 30-gauge galvanized steel or 26-gauge aluminized steel if allowed by local codes. This reduction is based on information in the International Residential Codes Section M1601.1 (2006 edition).
  - Do not install 2 elbows together.
  - Use no more than three 90° elbows.
  - If an elbow is used, install it as far away as possible from the hood's vent motor exhaust opening.

## Cutout Dimensions

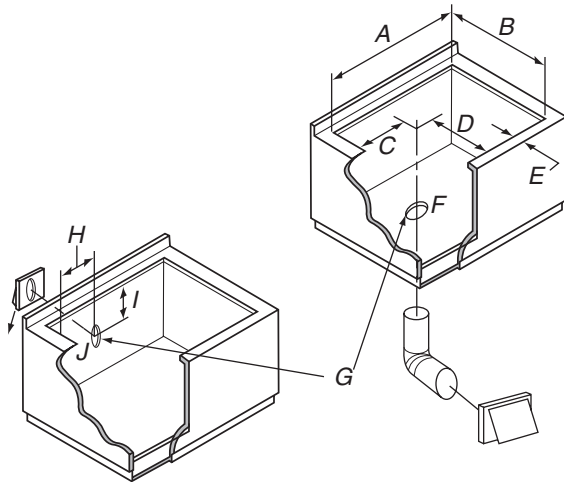

- A. 29" ± 1/16" (73.6 cm ± 0.2 cm) on 30" (76.2 cm) models  
43¼" ± 1/16" (109.9 cm ± 0.2 cm) on 45" (114.3 cm) models
- B. 21" ± 1/16" (53.3 cm ± 0.2 cm) maximum on both 30" (76.2 cm) and 45" (114.3 cm) models
- C. 9¾" (23.8 cm) on both 30" (76.2 cm) models and 45" (114.3 cm) models
- D. 7¾" (19.2 cm) on both 30" (76.2 cm) and 45" (114.3 cm) models
- E. 1⅞" (4.8 cm) minimum space to front edge of cooktop
- F. Floor exhaust option
- G. 6⅞" (15.6 cm) for 6" vent system
- H. 9¾" (21.9 cm) on both 30" (76.2 cm) and 45" (114.3 cm) models
- I. 13" (33.0 cm) on both 30" (76.2 cm) and 45" (114.3 cm) models
- J. Wall exhaust option

- Make sure there is a minimum of 18" (45.7 cm) of straight vent between the elbows if more than one elbow is used.
- Elbows too close together can cause excess turbulence that reduces airflow.
- Do not use a 5" (12.7 cm) elbow in a 6" (15.2 cm) or 3 1/4" x 10" (8.3 x 25.4 cm) system.
- Do not reduce to a 5" (12.7 cm) system after using 6" (15.2 cm) or 3 1/4" x 10" (8.3 x 25.4 cm) fittings.
- Avoid forming handmade crimps. Handmade crimps may restrict airflow.
- Use a Jenn-Air® vent cap for proper performance. If an alternate wall or roof cap is used, be certain the cap size is not reduced and that it has a back draft damper.

The length of vent system and number of elbows should be kept to a minimum to provide efficient performance.

The maximum equivalent length of the vent system is 60 ft (18.3 m). For altitudes above 4,500 ft (1272 m), reduce recommended vent run by 20% for best performance.

### Cold Weather Installations

An additional back draft damper should be installed to minimize backward cold air flow and a thermal break installed to minimize conduction of outside temperatures as part of the vent system. The damper should be on the cold air side of the thermal break.

### Makeup Air

Local building codes may require the use of makeup air systems when using ventilation systems greater than specified CFM of air movement. The specified CFM varies from locale to locale. Consult your HVAC professional for specific requirements in your area.

## Venting Methods

Common venting methods are shown for a counter-mounted downdraft cooktop. The cooktop may be vented through the wall or floor.

### Option 1 - Roof Venting

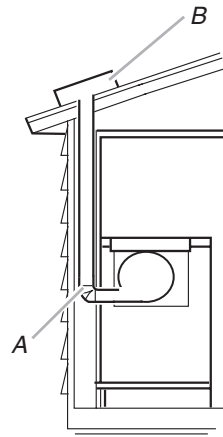

A. 6" (15.2 cm) round roof venting  
B. Roof cap

### Option 2 - Wall Venting

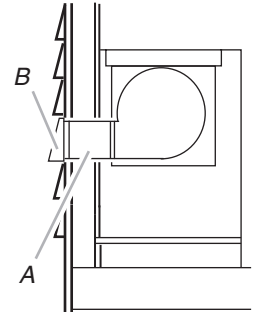

A. 6" (15.2 cm) round wall venting  
B. Wall cap

### Option 3 - Venting Between Floor Joist

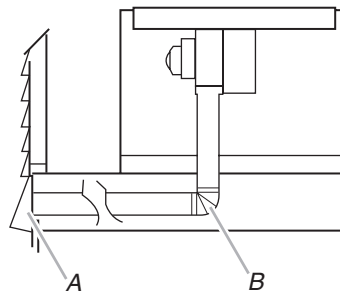

A. Wall cap  
B. 6" (15.2 cm) round wall venting

### Option 4 - Venting behind Cabinet Kick Plate

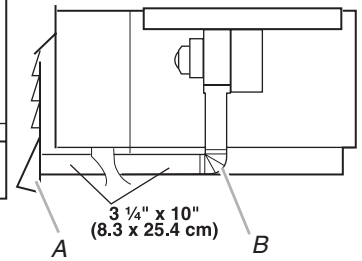

A. Wall cap  
B. 6" (15.2 cm) round wall venting

## Concrete Slab Installations - Exhaust Through Window Well

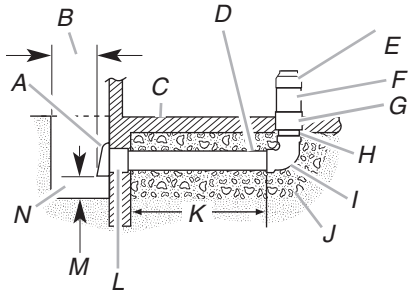

- A. Wall cap
- B. 12" (30.5 cm) minimum
- C. Concrete slab
- D. 6" (15.2 cm) round PVC sewer pipe
- E. 5" to 6" (12.7 cm to 15.2 cm) transition
- F. 6" (15.2 cm) round metal duct
- G. 6" (15.2 cm) round PVC coupling
- H. 6" (15.2 cm) round PVC sewer pipe
- I. 6" (15.2 cm) round 90° PVC sewer pipe elbow
- J. Tightly pack gravel or sand completely around pipe.
- K. 42 ft (12.8 m) max.
- L. 6" (15.2 cm) round PVC coupling
- M. 6" (15.2 cm) minimum
- N. Window well



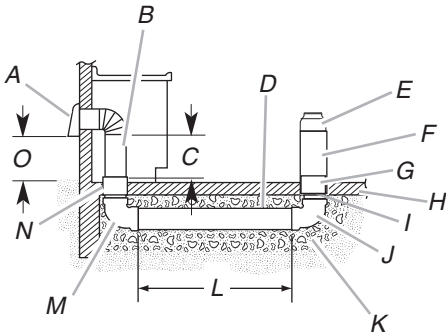

## Concrete Slab Installations - Exhaust Through Wall



- A. Wall cap
- B. 6" (15.2 cm) round metal vent
- C. 16" (40.6 cm) maximum
- D. 6" (15.2 cm) round PVC sewer pipe
- E. 5" to 6" (12.7 cm to 15.2 cm) transition
- F. 6" (15.2 cm) round metal duct
- G. 6" (15.2 cm) round PVC coupling
- H. Concrete slab
- I. 6" (15.2 cm) round PVC sewer pipe
- J. 6" (15.2 cm) round 90° PVC sewer pipe elbow
- K. Tightly pack gravel or sand completely around pipe.
- L. 30 ft (9.1 m) max.
- M. 6" (15.2 cm) round 90° PVC sewer pipe elbow
- N. 6" (15.2 cm) round PVC coupling
- O. 12" (30.5 cm) minimum

## Calculating Vent System Length

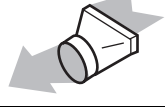
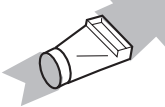
To calculate the length of the system you need, add the equivalent feet (meters) for each vent piece used in the system.

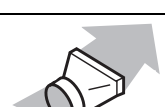
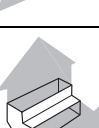
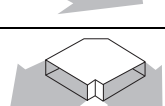
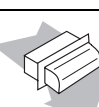
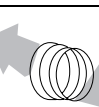
Vent Piece	6" (15.2 cm) Round	
45° elbow	2.5 ft (0.8 m)	
90° elbow	5.0 ft (1.5 m)	
6" (15.2 cm) wall cap	0.0 ft (0.0 m)	
3 1/4" x 10" (8.3 cm x 25.4 cm) to 6" (15.2 cm) transition	4.5 ft (1.4 m)	
6" (15.2 cm) to 3 1/4" x 10" (8.3 cm x 25.4 cm) transition	1 ft (0.3 m)	
3 1/4" x 10" (8.3 cm x 25.4 cm) to 6" (15.2 cm) 90° elbow transition	9.0 ft (2.7 m)	
6" (15.2 cm) to 3 1/4" x 10" (8.3 cm x 25.4 cm) 90° elbow transition	5.0 ft (1.5 m)	
3 1/4" x 10" (8.3 cm x 25.4 cm) 90° elbow	5.0 ft (1.5 m)	
3 1/4" x 10" (8.3 cm x 25.4 cm) flat elbow	12.0 ft (3.7 m)	
3 1/4" x 10" (8.3 cm x 25.4 cm) wall cap	0.0 ft (0.0 m)	
5" to 6" (12.7 cm to 15.2 cm) transition	1 ft (0.3 m)	

## Example vent system

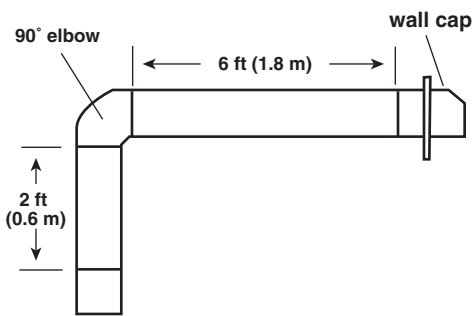

1 - 90° elbow	= 5 ft (1.5 m)
8 ft (2.4 m) straight	= 8 ft (2.4 m)
1 - wall cap	= 0 ft (0 m)
<b>System length</b>	<b>= 13 ft (3.9 m)</b>

**NOTE:** Flexible vent is not recommended. Flexible vent creates back pressure and air turbulence that greatly reduce performance.

### Determine Range Blower Setting

This cooktop is equipped with a dual range blower. It is shipped from the factory in the low range for most installations. If the equivalent duct length exceeds 30 ft (9.1 m), it must be converted to high range. Do not convert the blower to high range for shorter lengths; this will cause excessive noise and conditioned air loss. Convert blower before installing into countertop if necessary.

## ⚠ WARNING

### Excessive Weight Hazard

**Use two or more people to move and install cooktop.**  
**Failure to do so can result in back or other injury.**

### To Convert to High Range:

- Using 2 or more people, place cooktop on floor with front edge and plenum down.
- Remove the four acorn nuts (A) that attach the blower motor assembly to the blower exhaust scroll.
- Remove the blower motor assembly (B) from the blower exhaust scroll (E).
- Slowly reach in the blower exhaust scroll opening and remove the snap ring (C).
- Gently remove the restrictor ring (D).
- Place the motor assembly back on the studs of the blower exhaust scroll.

- Reattach the four acorn nuts to secure the blower motor assembly back to the blower exhaust scroll.

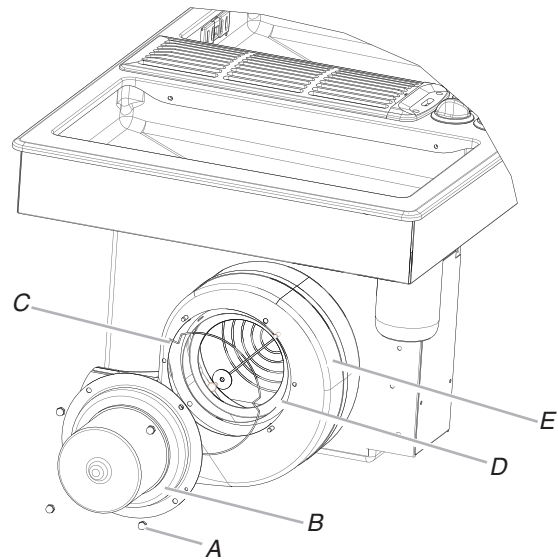

- A. Acorn nuts (4)
- B. Blower motor assembly
- C. Snap ring
- D. Restrictor ring
- E. Blower exhaust scroll

## Electrical Requirements

## ⚠ WARNING



### Electrical Shock Hazard

**Disconnect power before servicing.**

**Use 8 gauge copper wire.**

**Electrically ground cooktop.**

**Failure to follow these instructions can result in death, fire, or electrical shock.**

If codes permit and a separate ground wire is used, it is recommended that a qualified electrical installer determine that the ground path and wire gauge are in accordance with local codes.

Check with a qualified electrical installer if you are not sure the cooktop is properly grounded.



Make sure that the electrical connection and wire size are adequate and in conformance with the National Electrical Code, ANSI/NFPA 70-latest edition or CSA Standards C22.1-94, Canadian Electrical Code, Part 1 and C22.2 No. O-M91-latest edition, and all local codes and ordinances.

A copy of the above code standards can be obtained from:

National Fire Protection Association  
1 Batterymarch Park  
Quincy, MA 02169-7471

CSA International  
8501 East Pleasant Valley Road  
Cleveland, OH 44131-5575

### Before You Make the Electrical Connection:

To properly install your cooktop, you must determine the type of electrical connection you will be using and follow the instructions provided for it here.

- A 4-wire or 3-wire, single phase, 120/240 volt, 60 Hz., AC only electrical supply is required on a separate, 40-amp circuit (45" [114.3 cm] models) or 40-amp circuit (30" [76.2 cm] models), fused on both sides of the line.
- The cooktop should be connected directly to the junction box in the cabinet through the flexible metal conduit. The flexible, armored cable extending from the fuse box or circuit breaker box should be connected directly to the cooktop wiring box.
- Locate the junction box in the cabinet to allow as much slack as possible between the junction box and the cooktop so that the cooktop can be moved if servicing becomes necessary in the future.
- A UL listed or CSA approved conduit connector must be provided at each end of the power supply cable (at the cooktop wiring box and at the junction box in the cabinet).
- If the house has aluminum wiring follow the procedure below:
  1. Connect a section of solid copper wire to the pigtail leads.
  2. Connect the aluminum wiring to the added section of copper wire using special connectors and/or tools designed and UL listed for joining copper to aluminum.

Follow the electrical connector manufacturer's recommended procedure. Aluminum/copper connection must conform with local codes and industry accepted wiring practices.

# INSTALLATION INSTRUCTIONS

## Prepare Cooktop

Decide on the final location for the cooktop.

### **! WARNING**

#### **Excessive Weight Hazard**

**Use two or more people to move and install cooktop.**

**Failure to do so can result in back or other injury.**

1. Open product as instructed on product packaging.
2. Remove shipping materials and tape from cooktop.
3. Remove vent grille and grates if present.

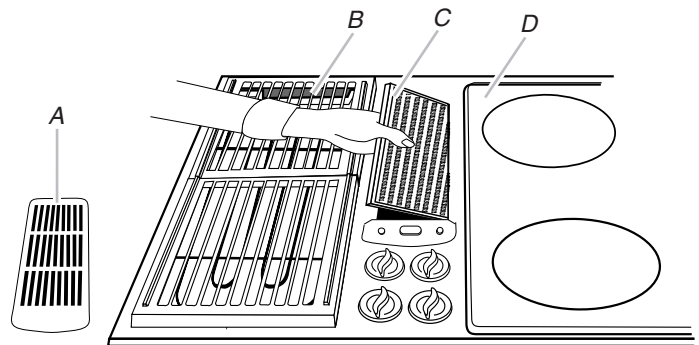

A. Vent grille (already removed)  
B. Grates  
C. Removable grease filter  
D. Radiant element cartridge

4. Remove the removable grease filter by lifting the filter out.
5. Using 2 or more people, remove the cooktop from the carton.
6. Use foam end caps from the packaging as a work surface for the floor or countertop.
7. Using 2 or more people, place the cooktop on the foam end caps.
8. Avoid placing the cooktop face down on the control knobs.
9. Turn tie down bolt on each end of cooktop burner box bottom counter clockwise so the bolt does not protrude beyond the side wall of the burner box bottom.



## Rotate Blower - Optional

**IMPORTANT:** The following additional steps must be performed if the product is being installed in peninsula or island cabinetry. The blower exhaust scroll is shipped from the factory set to exhaust straight out the back of the cabinet through an exterior wall.

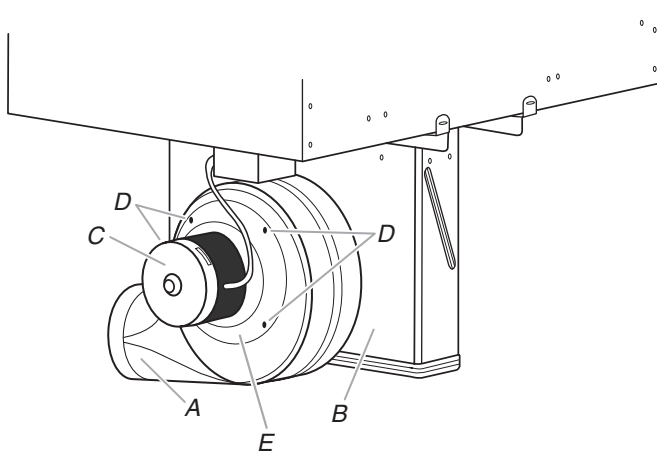

- A. Blower exhaust scroll
- B. Plenum
- C. Blower motor
- D. 10-32 machine nuts (4)
- E. Motor mounting plate

### To rotate blower:

1. Remove the vent grille and grease filter.
2. Using a  $\frac{3}{8}$ " socket on a ratchet, reach into the plenum and loosen the four #10-32 machine nuts one-half of a turn.
3. With the nuts loosened, the blower exhaust scroll can be easily rotated downward.

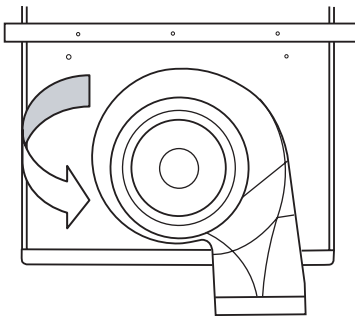

4. Retighten each nut with the  $\frac{3}{8}$ " socket and ratchet.
5. Reinstall the grease filter and vent grille.

### To rotate blower motor:

1. Using a ratchet with a  $\frac{3}{8}$ " socket and supporting the motor with one hand, remove the four machine nuts that attach the blower motor to the exhaust scroll.
2. Remove the blower motor and wheel assembly from the weld studs.

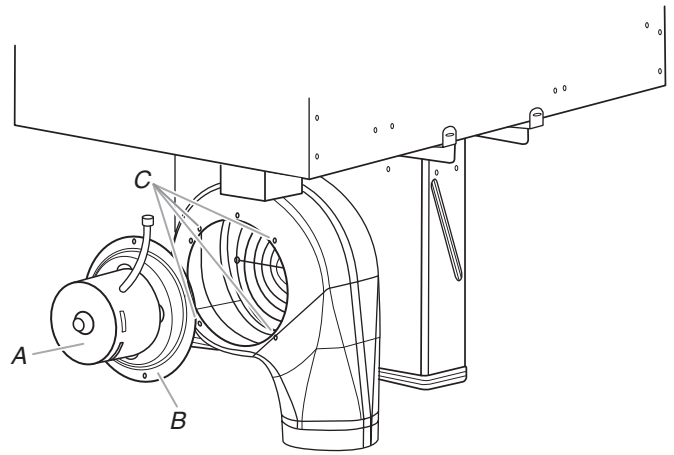

- A. Blower motor
- B. Motor mounting plate
- C. Weld stud location

3. When the motor mounting plate clears the threaded weld studs, rotate the assembly clockwise 90° and reinstall the four #10-32 machine nuts.

## Install Cooktop

- Using 2 or more people, place cooktop right side up into the cutout.

**NOTE:** Make sure that the front edge of the cooktop is parallel to the front edge of the countertop. If repositioning is needed, lift entire cooktop up from the cutout to avoid scratching the countertop.

- Connect blower exhaust scroll to ducting.
- Use vent clamps to secure the ducting to the blower exhaust scroll.
- Turn tie down bolts clockwise until they contact the bottom side of the countertop, then tighten  $\frac{1}{4}$  turn more.
- Install grease container(s) to bottom of cooktop.
- Reinstall grease filter.
- Reinstall vent grille.

## Make Electrical Connection

### **⚠ WARNING**



#### Electrical Shock Hazard

**Disconnect power before servicing.**

**Use 8 gauge copper wire.**

**Electrically ground cooktop.**

**Failure to follow these instructions can result in death, fire, or electrical shock.**

This cooktop is manufactured with a white (neutral) power supply wire twisted together with a green (or bare) grounding wire connected to the cooktop.

Home power supply cable and connectors are not provided.

See the “Electrical Connection Options” chart to complete installation for your type of electrical connection.

## Electrical Connection Options

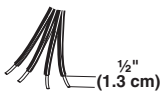
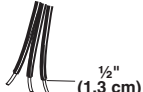
If your home has:	And you will be connecting to:	Go to Section:
4-wire 	A fused disconnect or circuit breaker box	4-Wire Cable from Power Supply
3-wire 	A fused disconnect or circuit breaker box	3-Wire Cable from Power Supply

### 4-Wire Cable from Home Power Supply to 4-Wire Cable to Cooktop

**IMPORTANT:** Use the 4-wire cable from home power supply in the U.S. where local codes do not allow grounding through neutral, New Branch circuit installations (1996 NEC), mobile homes and recreational vehicles, new construction, and in Canada.

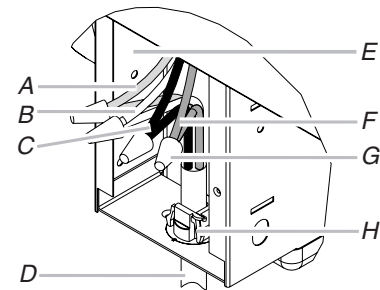

- |                                 |  |
|---------------------------------|--|
| A. Green (or bare) ground wires | E. Plenum wiring box                       |
| B. White wires                  | F. Red wires                               |
| C. Black wires                  | G. UL listed wire connector                |
| D. Cable from home power supply | H. UL listed or CSA approved strain relief |

- Disconnect power.
- Remove wiring box cover from the cooktop plenum.
- Remove the appropriate knockout for the size of the home power supply cable on the bottom side of the cooktop wiring box. Use a UL listed or CSA approved strain relief to connect home power supply cable to cooktop wiring box.
- Connect the green (or bare) ground wire from the home power supply to the green (or bare) ground wire in the plenum wiring box using the UL listed wire connectors.
- Connect the 2 black wires together using the UL listed wire connectors.
- Connect the 2 red wires together using the UL listed wire connectors.
- Connect the 2 white wires together the UL listed wire connectors.
- Tighten screws on the strain relief.
- Install cooktop wiring box cover on plenum wiring box.

### 3-Wire Cable from Home Power Supply to 4-Wire Cable to Cooktop - U.S. only

**IMPORTANT:** Use the 3-wire cable from power supply where local codes permit connecting the frame-ground conductor to the neutral (white) junction box wire.

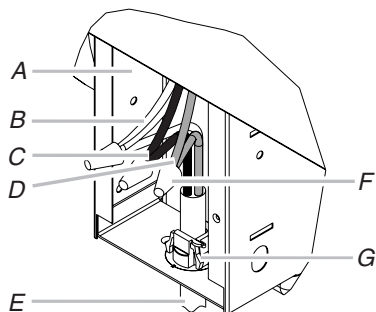

- |   |  |
|---|--|
| A. Plenum wiring box                                  | D. Red wires                               |
| B. White wire and green (or bare) wire (from cooktop) | E. Cable from home power supply            |
| C. Black wires  | F. UL listed wire connector                |
|   | G. UL listed or CSA approved strain relief |

1. Disconnect power.
2. Remove wiring box cover from the cooktop plenum.
3. Remove the appropriate knockout for the size of the home power supply cable on the bottom side of the cooktop wiring box. Use a UL listed or CSA approved strain relief to connect home power supply cable to cooktop wiring box.
4. Connect the green (or bare) ground wire and the white wire from in the plenum wiring box to the white wire from the home power supply cable using the UL listed wire connectors.
5. Connect the 2 black wires together using the UL listed wire connectors.
6. Connect the 2 red wires together using the UL listed wire connectors.
7. Tighten screws on the strain relief.
8. Install cooktop wiring box cover on plenum wiring box.

### Complete Installation

1. Check that all parts are now installed. If there is an extra part, go back through the steps to see which step was skipped.
2. Check that you have all your tools.
3. Dispose of/recycle all packaging materials.
4. Use a mild solution of liquid household cleaner and warm water to clean cooktop before use. Dry thoroughly with a soft cloth. For more information, see the "Cooktop Care" section of the Use and Care Guide.
5. Read "Cooktop Use" in the cooktop Use and Care Guide.
6. Reconnect power.
7. Use the Flow Tester Card provided with your cooktop to check the airflow (see card for step-by-step instructions).

**NOTE:** If the cooktop does not work after turning on the power, check that a circuit breaker has not tripped or a household fuse has not blown. See "Troubleshooting" section in the Use and Care Guide for further information.

#### If you need Assistance or Service:

Please reference the "Assistance or Service" section of the Use and Care Guide or contact the dealer from whom you purchased your cooktop.

---

## Notes

**W10298937B**

© 2012.  
All rights reserved.  
Tous droits réservés.

©Registered Trademark™Trademark of Jenn-Air, U.S.A. Used under license by Maytag Limited in Canada.  
©Marque déposée™Marque de commerce de Jenn-Air, U.S.A. Emploi sous licence par Maytag Limited au Canada.

2/12  
Printed in U.S.A.  
Imprimé aux É.-U.