



# DISHWASHER USER INSTRUCTIONS

Thank you for Choosing IKEA® Appliances.

We hold our company to the highest quality standards and it is important to us that you have a positive experience owning a IKEA® product.

For your convenience, we have provided an easy to follow User Instruction Book. These instructions include a “Troubleshooting” section to help you through any problems you may encounter.

Have your complete model and serial number ready. You can find your model and serial number on the label located near the door on the right-hand or left-hand side of the dishwasher interior.

For warranty concerns, do not take the appliance back to the store. Please contact us in U.S.A. or Canada at **1-866-664-2449**.

This product features a Limited Warranty - See the “Warranty” section for complete details. IKEA® appliances carry a 5-year warranty (excludes LAGAN family - see warranty for coverage details).

**NOTE:** Proof of Purchase is required to obtain warranty service.

---

## TABLE OF CONTENTS

<b>IKEA MAJOR APPLIANCE WARRANTY.....</b>	<b>2</b>
<b>ASSISTANCE OR SERVICE .....</b>	<b>3</b>
<b>DISHWASHER SAFETY .....</b>	<b>3</b>
<b>WHAT'S NEW IN YOUR DISHWASHER.....</b>	<b>5</b>
<b>QUICK STEP .....</b>	<b>6</b>
<b>DISHWASHER USE.....</b>	<b>7</b>
<b>CYCLE AND OPTION DESCRIPTIONS.....</b>	<b>9</b>
<b>FILTRATION SYSTEM .....</b>	<b>11</b>
<b>DISHWASHER CARE .....</b>	<b>13</b>
<b>TROUBLESHOOTING .....</b>	<b>14</b>

---

---

## IKEA Major Appliance Warranty

### How long is the IKEA limited warranty valid?

This limited warranty is valid for five years from the date of purchase, when this major appliance is operated and maintained according to instructions attached to or furnished with the product, unless the appliance is named LAGAN in which case this limited warranty is valid for two years from the date of purchase. This limited warranty is valid only in the United States or Canada and applies only when the major appliance is used in the country in which it was purchased. Proof of original purchase date is required to obtain service under this limited warranty.

### Which appliances are not covered by the IKEA five (5) year limited warranty?

For major appliances named "LAGAN," this limited warranty is valid for two years from the date of purchase.

### Who will execute the service?

This limited warranty is provided by Whirlpool Corporation or Whirlpool Canada LP (hereafter "Whirlpool"). Service must be provided by a Whirlpool designated service company.

### What does this limited warranty cover?

The limited warranty will pay for factory specified parts and repair labor to correct defects in materials or workmanship that existed when the major appliance was purchased. The exceptions are specified under the headline "What is not covered under this limited warranty?".

### What will be done to correct the problem?

The designated service company will examine the product and decide, at its sole discretion, if it is covered under this limited warranty. If considered covered, the designated service company will then repair the defect. Your sole and exclusive remedy under this limited warranty shall be product repair as provided herein.

### What is not covered under this limited warranty?

- Service calls to correct the installation of your major appliance, to instruct you on how to use your major appliance, to replace or repair house fuses, or to correct house wiring or plumbing.
- Service calls to repair or replace appliance light bulbs, air filters or water filters. Consumable parts are excluded from warranty coverage.
- Replacement parts or repair labor if this major appliance is used for other than normal, single-family household use or when it is used in a manner that is inconsistent to published user or operator instructions and/or installation instructions.
- Damage resulting from accident, alteration, misuse, abuse, fire, flood, acts of God, improper installation, installation not in accordance with electrical or plumbing codes, or use of consumables or cleaning products not approved for use.
- Cosmetic damage, including scratches, dents, chips or other damage to the finish of your major appliance, unless such damage results from defects in materials or workmanship and is reported within 30 days from the date of purchase.
- Any food loss or medicine loss due to refrigerator or freezer product failures.
- Pick up and delivery. This major appliance is intended to be repaired in your home.
- Repairs to parts or systems resulting from unauthorized modifications made to the appliance.
- Expenses for travel and transportation for product service if your major appliance is located in a remote area where service by an authorized servicer is not available.
- The removal and reinstallation of your major appliance if it is installed in an inaccessible location or is not installed in accordance with published installation instructions.
- Replacement parts or repair labor on major appliances with original model/serial numbers that have been removed, altered or cannot be easily determined.

**The cost of repair or replacement under these excluded circumstances shall be borne by the customer.**

### Disclaimer of Implied Warranties

IMPLIED WARRANTIES, INCLUDING ANY IMPLIED WARRANTY OF MERCHANTABILITY OR IMPLIED WARRANTY OF FITNESS FOR A PARTICULAR PURPOSE, ARE LIMITED TO FIVE YEARS (TWO YEARS FOR MAJOR APPLIANCES NAMED "LAGAN") OR THE SHORTEST

PERIOD ALLOWED BY LAW. Some states and provinces do not allow limitations on the duration of implied warranties of merchantability or fitness, so this limitation may not apply to you. This warranty gives you specific legal rights, and you also may have other rights that vary from state to state or province to province.

### Limitation of Remedies; Exclusion of Incidental and Consequential Damages

YOUR SOLE AND EXCLUSIVE REMEDY UNDER THIS LIMITED WARRANTY SHALL BE PRODUCT REPAIR AS PROVIDED HEREIN. WHIRLPOOL SHALL NOT BE LIABLE FOR INCIDENTAL OR CONSEQUENTIAL DAMAGES. Some states and provinces do not allow the exclusion or limitation of incidental or consequential damages, so these limitations and exclusions may not apply to you. This warranty gives you specific legal rights, and you also may have other rights that vary from state to state or province to province.

### How to reach us if you need our service

If outside the 50 United States and Canada, contact your authorized IKEA retailer to determine if another warranty applies.

## Assistance or Service

If you do not have access to the Internet and you need assistance using your product or you would like to schedule service, you may contact IKEA at the number below.

Have your complete model number ready. You can find your model and serial number on the label located near the door on the right-hand or left-hand side of the dishwasher interior.

For assistance or service in the U.S.A. or Canada, call 1-866-664-2449.

If you need further assistance, you can write to IKEA with any questions or concerns at the address below:

In the U.S.A.:

Whirlpool Brand Home Appliances  
Customer Experience Center  
553 Benson Road  
Benton Harbor, MI 49022-2692

In Canada:

Whirlpool Brand Home Appliances  
Customer Experience Centre  
200 - 6750 Century Ave.  
Mississauga, Ontario L5N 0B7

Please include a daytime phone number in your correspondence.

Please keep this User Instructions and model number information for future reference.

## Dishwasher Safety

### Your safety and the safety of others are very important.

We have provided many important safety messages in this manual and on your appliance. Always read and obey all safety messages.



This is the safety alert symbol.

This symbol alerts you to potential hazards that can kill or hurt you and others.

All safety messages will follow the safety alert symbol and either the word "DANGER" or "WARNING."

These words mean:

**⚠ DANGER**

**You can be killed or seriously injured if you don't immediately follow instructions.**

**⚠ WARNING**

**You can be killed or seriously injured if you don't follow instructions.**

All safety messages will tell you what the potential hazard is, tell you how to reduce the chance of injury, and tell you what can happen if the instructions are not followed.

### IMPORTANT SAFETY INSTRUCTIONS

**WARNING:** When using the dishwasher, follow basic precautions, including the following:

- Read all instructions before using the dishwasher.
- Use the dishwasher only for its intended function.
- Use only detergents or rinse agents recommended for use in a dishwasher, and keep them out of the reach of children.
- When loading items to be washed:
  - 1) Locate sharp items so that they are not likely to damage the door seal; and
  - 2) Load sharp knives with the handles up to reduce the risk of cut-type injuries.
- Do not wash plastic items unless they are marked "dishwasher safe" or the equivalent. For plastic items not so marked, check the manufacturer's recommendations.
- Do not touch the heating element during or immediately after use.
- Do not operate the dishwasher unless all enclosure panels are properly in place.
- Do not tamper with controls.
- Do not abuse, sit on, or stand on the door, lid, or dish racks of the dishwasher.
- To reduce the risk of injury, do not allow children to play in or on the dishwasher.
- Under certain conditions, hydrogen gas may be produced in a hot water system that has not been used for two weeks or more. **HYDROGEN GAS IS EXPLOSIVE.** If the hot water system has not been used for such a period, before using the dishwasher turn on all hot water faucets and let the water flow from each for several minutes. This will release any accumulated hydrogen gas. As the gas is flammable, do not smoke or use an open flame during this time.
- Remove the door or lid to the washing compartment when removing an old dishwasher from service or discarding it.

**SAVE THESE INSTRUCTIONS**

## GROUNDING INSTRUCTIONS

### ■ For a grounded, cord-connected dishwasher:

The dishwasher must be grounded. In the event of a malfunction or breakdown, grounding will reduce the risk of electric shock by providing a path of least resistance for electric current. The dishwasher is equipped with a cord having an equipment-grounding conductor and a grounding plug. The plug must be plugged into an appropriate outlet that is installed and grounded in accordance with all local codes and ordinances.

**WARNING:** Improper connection of the equipment-grounding conductor can result in a risk of electric shock.

Check with a qualified electrician or service representative if you are in doubt whether the dishwasher is properly grounded. Do not modify the plug provided with the dishwasher; if it will not fit the outlet, have a proper outlet installed by a qualified electrician.

### ■ For a permanently connected dishwasher:

The dishwasher must be connected to a grounded metal, permanent wiring system, or an equipment-grounding conductor must be run with the circuit conductors and connected to the equipment-grounding terminal or lead on the dishwasher.

**SAVE THESE INSTRUCTIONS**



## ⚠ WARNING

### Tip Over Hazard

**Do not use dishwasher until completely installed.**

**Do not push down on open door.**

**Doing so can result in serious injury or cuts.**

State of California Proposition 65 Warnings:

WARNING: This product contains one or more chemicals known to the State of California to cause cancer.

WARNING: This product contains one or more chemicals known to the State of California to cause birth defects or other reproductive harm.

# What's New in Your Dishwasher

## Energy

Congratulations on purchasing your water and energy efficient dishwasher! This dishwasher cleans by spraying the dishes with water and pauses to allow the detergent to soak into and release the soils on the dishes. The cycles are longer due to the soak and pauses for exceptional cleaning. Several models contain an optical water sensor. The optical water sensor is used to determine the optimum water and energy consumption for great cleaning performance. Efficient dishwashers run longer to save water and energy, just as driving a car slower saves on gas. The first cycle using the sensor will run longer to calibrate the optical sensor.



## Performance

### Rinse Aid

Using rinse aid will optimize your drying and wash performance. This dishwasher is specifically designed to be used with rinse aid for improved drying performance and controlling buildup of hard water deposits. Energy efficient dishwashers use less water and energy, so they depend on the water "sheeting" action of rinse aid for total optimal performance.

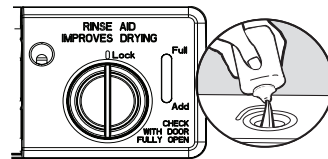

### Detergent

The United States and Canada have passed a restriction limiting the amount of phosphorus (phosphates) in the household dishwasher detergents. Major manufacturers have reformulated their dishwasher detergent for this change in detergents as another step in eco-conscious awareness. With these recent changes, it is recommended to use tablets and packs for convenience and improved performance.

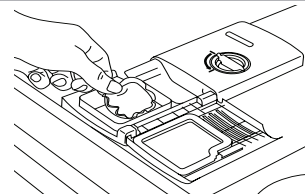

### Filtration System

Your dishwasher has the latest technology in dishwasher filtration. This triple filtration system minimizes sound and optimizes water and energy conservation while providing optimal cleaning performance. Maintenance of your filters regularly will sustain peak cleaning performance. We suggest you clean both your upper and lower filters and rinse them under running water at least once a month.

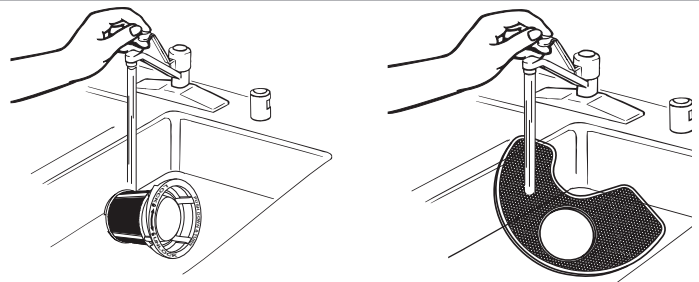

# Quick Step

## 1 Prepare and load dishwasher.



Spin the spray arms. They should turn freely.

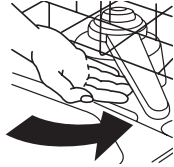

## 2 Add detergent and rinse aid.

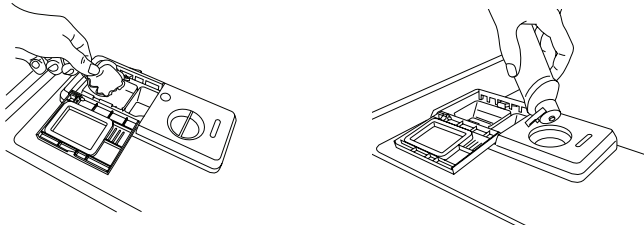

## 3 Select a cycle and option (cycles and options vary by model).

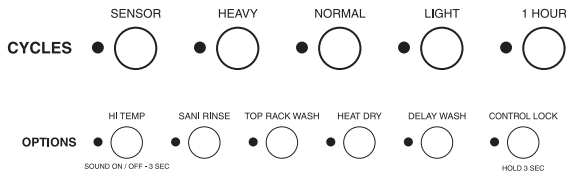

## 4 Start dishwasher.

For models with controls on top of the door, select wash cycle, option, and press START/RESUME before closing the door. Push door firmly closed within 4 seconds of pressing START/RESUME. The door latches automatically. For models with front controls, select the wash cycle, options, and press START/RESUME or press START/RESUME to repeat the same cycle and options as in the previous wash cycle.



## 5 Unload and clean the filter.

See "Recommended Time Interval to Clean Your Filter" in the "Filtration System" section for the recommended cleaning schedule.

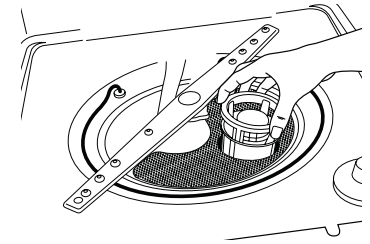
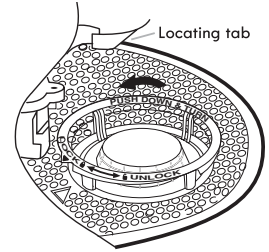



# Dishwasher Use

## STEP 1

### Prepare and Load the Dishwasher

**IMPORTANT:** Remove leftover food, bones, toothpicks, and other hard items from the dishes. Remove labels from containers before washing.

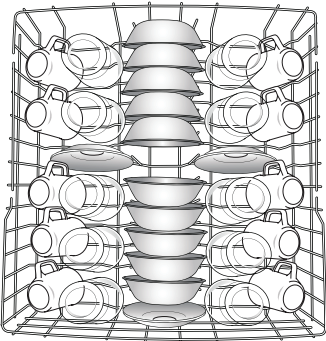

10-place setting upper rack

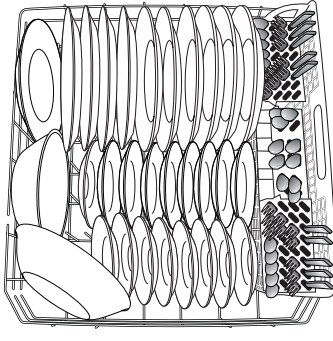

10-place setting lower rack

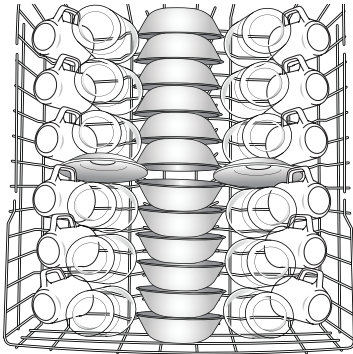

12 -place load – upper rack

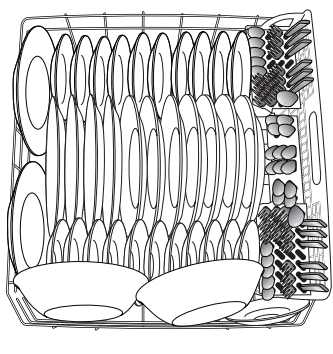

12-place load – lower rack

- Make sure when the dishwasher door is closed no items are blocking detergent dispenser.
- Items should be loaded with soiled surfaces facing down and inward to the spray as shown. This will improve cleaning and drying results.
- Avoid overlapping items, like bowls or plates that may trap food.
- Place plastics, small plates, and glasses in upper rack. Wash only items marked “dishwasher safe.”
- To avoid thumping/clattering noises during operation: Load dishes so they do not touch one another. Make sure lightweight load items are secured in racks.
- Check that nothing blocks the upper or lower spray arms. Items in rack can block the spray arms.

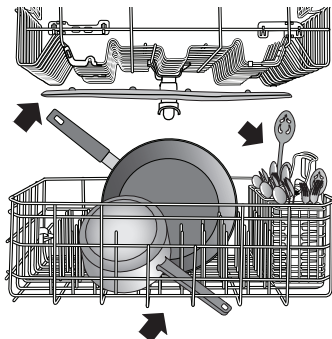

- When loading silverware, always place sharp items pointing down. Mix other items pointing up and some pointing down.



### Easy-to-Remove Third Level Rack

If additional space is needed in the upper rack, the third level rack can easily be removed.

To remove, fully extend rack until it stops. Then, open the track stops on each side and slide the rack out to remove. Low profile items such as serving utensils and silverware may be loaded on the third level rack.

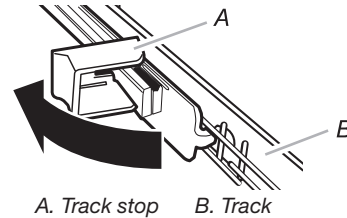

A. Track stop B. Track

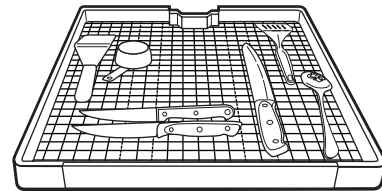

### Premium Adjustable 2-Position Top Rack

You can raise or lower the top rack to fit tall items in either the top or bottom rack. Adjusters are located on each side of the top rack.

#### To raise the rack:

Press both rack adjuster thumb levers and lift the rack until it is in the up position and level.

#### To lower the rack:

Press both rack adjuster thumb levers and slide the rack to its down position and level.

**NOTE:** The top rack must be level.

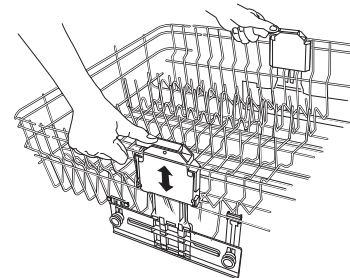

## STEP 2

### Add Detergent

#### Hinged lid style

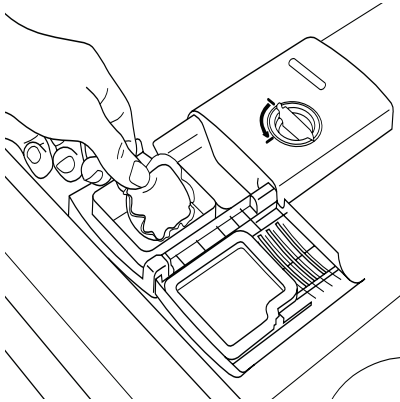

### Premeasured Detergents

High-quality premeasured tablets and packs are recommended for improved performance.

Quality tablets and packs have been proven better than powder, liquid, or gel detergents at reducing filming on dishes. Using tablets and packs over time will start to reduce or eliminate white film. They are suitable for all hardness and soil levels. Also, by using a rinse aid, you can minimize repeat buildup of white film (not all packs and tablets contain rinse aid). Always place premeasured detergents in main compartment and close the lid.

**NOTE:** Follow instructions on the package when using other dishwasher detergent types.

- Use automatic dishwasher detergent only. Add detergent just before starting a cycle.
- Fresh automatic dishwasher detergent results in better cleaning. Store tightly closed detergent container in a cool dry place.

### Powders and Gels

Water Hardness	Soil Level	Prewash Compartment*	Main Wash Compartment
<b>Soft</b> (0-4 grains per U.S. gallon)	Light	None	"Soft" fill line
	Normal	None	"Soft" fill line
	Heavy	Full	"Soft" fill line
<b>Medium</b> (5-9 grains per U.S. gallon)	Light	None	"Soft" fill line
	Normal	Full	Full**
<b>Hard</b> (10-14 grains per U.S. gallon)	Light	Full	Full**
	Normal	Full	Full**
	Heavy	Full	Full**

\*The prewash compartment is on top of the sliding door of the dispenser.

\*\*A full main wash compartment contains 2 Tbsp (30 ml).

**IMPORTANT:** Extremely hard water mineral deposits (15 grains per U.S. gallon or more) can cause damage to your dishwasher and make it difficult to achieve good results. A water softener is recommended to avoid damage and achieve good results. You may bring your water samples to Sears to check hardness level.

**NOTE:** Follow instructions on the package when using other dishwasher detergent types.

## STEP 3

### Add Rinse Aid

#### Hinged lid style

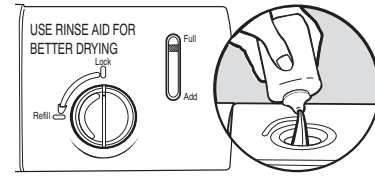

**IMPORTANT:** Your dishwasher is designed to use rinse aid. The use of rinse aid greatly improves drying by allowing water to drain from the dishes after the final rinse. Rinse aid also keeps water from forming droplets that can dry as spots or streaks.

#### Filling the dispenser

The dispenser holds 5 oz (150 mL) of rinse aid. Under most conditions, this will last one to three months.

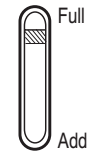

**NOTE:** Indicator reads correct fill level when door is completely opened.

Add rinse aid to hinged lid style dispenser by twisting the dispenser cap ¼ turn clockwise to open and lift off. Pour rinse aid into the opening until the indicator level is at "Full." Replace the dispenser cap and turn to "Lock." Make sure cap is fully locked.

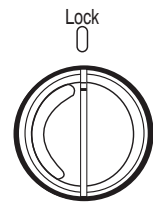

¼ turn clockwise to lock

#### Rinse Aid Setting

Your rinse aid dispenser is adjustable. For most water conditions, the factory setting will give good results. If you have hard water and notice calcium buildup on your dishwasher, you may want to try a higher setting. If you notice foam in your dishwasher, use a lower setting.



#### To adjust the setting:

Turn the arrow adjuster to a higher number to increase the amount of rinse aid.



## STEP 4

### Select a Cycle (cycles vary by model)

Press and hold the desired cycle button until the corresponding light is on. See “Cycle and Option Descriptions” charts in the following section.



**NOTE:** Heavier cycles and options affect cycle length. Some cycles and options will take up to 3½ hours to complete.

### Select Options (varies by model)

You can customize your cycles by pressing the options desired.



## STEP 5

### Start or Resume a Cycle

- If needed, run hot water at the sink nearest your dishwasher until the water is hot. Turn off water.
- If the START/RESUME button is located on top of door, push door firmly closed within 4 seconds of pressing START/RESUME. If door is not closed within 4 seconds, the Start button LED will flash, an audible tone will be heard, and cycle will not start.



**IMPORTANT:** If anyone opens the door (such as, for adding a dish, even during the Delay Hours option), the START/RESUME button must be pressed each time.

- If your START/RESUME button is located on front of door, push door firmly closed. The door latches automatically. Select the wash cycle, options and press START/RESUME or press START/RESUME to repeat the same cycle and options as in previous wash cycle.
- You can add an item at the beginning of the cycle. Open the door slowly and add the item. Press the START/RESUME keypad and close the door firmly within 4 seconds. If the door has been open more than 4 seconds the LED will flash, a tone will sound and the dishwasher will not resume unless you press START/RESUME again.
- The Clean indicator glows when the cycle is finished. Sanitized glows when Sani Rinse option is selected and sanitization levels occur.

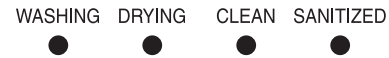

## Cycle and Option Descriptions







### CYCLE SELECTIONS

CYCLES		ESTIMATED WASH TIME W/O OPTIONS	WATER USAGE GALLONS (LITERS)
	This cycle senses the load size, soil amount, and toughness of soil, to adjust the cycle for improved cleaning, using only the amount of water and energy needed. The Sensor cycle is automatically selected if you first press the START/RESUME button.*	2:30 to 3:30	3.8 to 7.7 (14.4 to 29.3)
	Use for hard-to-clean, heavily soiled pots, pans, casseroles, and tableware.	2:20 to 3:30	8.4 (31.7)
	This cycle is recommended for daily, regular, or typical use to completely wash and dry a full load of normally soiled dishes. This dishwasher's government energy certifications were based on the Normal cycle with only the Heat Dry option selected.**	1:50 to 3:30	2.7 to 7.9 (10.4 to 30.0)
	Use for lightly soiled items or china and crystal. Includes a heated drying option.	1:45 to 3:30	2.7 to 7.9 (10.4 to 30.0)
	For fast results, 1 Hour wash will clean dishes using slightly more water and energy. Select the Heat Dry option to provide best dry performance.	1:00	6.2 (23.5)



\*The government energy certifications are not based on this cycle. See the Normal cycle description for the government energy certification cycle. Using the Sensor cycle may increase your energy usage.

\*\*No other washing and drying temperature options were selected, and the dishwasher was not subjected to truncated testing. Rinse aid was not used, and there was no detergent used in the prewash.

## OPTION SELECTIONS

	OPTIONS	CAN BE SELECTED WITH	WHAT IT DOES	ADDED TIME TO CYCLE	ADDED WATER GALLONS (LITERS)
	<p>Raises main wash temperature to improve cleaning for loads containing tough, baked-on food.</p>	<p><b>Sensor Heavy Normal</b></p>	<p>Raises the main wash temperature to 130°F (54°C).</p>	<p>0:00 to 0:40</p>	<p>0 to 3.0 (0 to 11.2)</p>
	<p>Sanitizes dishes and glassware in accordance with NSF International NSF/ANSI Standard 184 for Residential Dishwashers. Certified residential dishwashers are not intended for licensed food establishments. Only sanitizing cycles have been designed to meet the requirements of the NSF/ANSI 184 performance standard for soil removal and for sanitization efficacy. There is no intention, either directly or indirectly, that all cycles on a NSF/ANSI 184 certified dishwasher meet the NSF/ANSI 184 performance standard for soil removal and for sanitization efficacy. At end of the cycle, the “Sanitized” indicator will glow. If your load did not properly sanitize, the indicator will flash at the end of the cycle. This can happen if the cycle is interrupted, or if the water does not reach the required temperature. The light goes off when you open and close the door or press CANCEL.</p>	<p><b>Sensor Heavy Normal</b></p>	<p>Raises the main wash temperature to 140°F (60°C) and the final rinse temperature to 156°F (69°C).</p>	<p>0:00 to 2:20</p>	<p>1.2 to 6.2 (4.8 to 23.3)</p>
	<p>Can be selected with any cycle for washing a small load of dishes in the top rack.</p>	<p><b>Available with any cycle</b></p>		<p>Saves up to 0:20</p>	<p>0</p>
	<p>Dries dishes with heat. This option, with the use of rinse aid, will provides better drying performance. Plastic items are less likely to deform when loaded in the top rack. Use Heat Dry for optimum dry performance. Turn the Heat Dry option off for air dry.</p>	<p><b>Any cycle</b></p>	<p>Uses heating element to speed drying times. Heat Dry option defaults to On when any cycle is selected, except for 1 Hour and Rinse Only.</p>	<p>0:10 to 0:50</p>	<p>0</p>
	<p>Delays the start of the cycle for 4 hours. To delay the start:</p> <ol style="list-style-type: none"> <li>1. Select a wash cycle and options.</li> <li>2. Press DELAY WASH.</li> <li>3. Press START/RESUME to begin 4 hour delay.</li> </ol> <p><b>NOTE:</b> If the door is opened (such as to add a dish), the START/RESUME button must be pressed to resume the delay countdown.</p>	<p><b>Available with any cycle</b></p>	<p>Delays the start of a cycle for a maximum of 4 hours.</p>		

## CONTROLS AND CYCLE STATUS

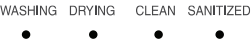
CONTROL	PURPOSE	COMMENTS
	Use the Control Lock option to avoid unintended use of the dishwasher between cycles. When the Lock indicator is lit, all buttons are disabled. The dishwasher door can still be opened/closed while the controls are locked.	
	Press to start or resume a wash cycle.	If the door is opened during a cycle or the power is interrupted, the START/RESUME LED flashes. The cycle will not resume until the START/RESUME keypad is pressed and the door is closed. <b>NOTE:</b> Push door firmly closed within 4 seconds of pressing START/RESUME or the dishwasher will not start. If door is not closed within 4 seconds the START/RESUME LED will flash and an audible tone will sound when the door is closed.
	To cancel a wash cycle after it has been started.	Press to cancel a wash cycle. then, close the door firmly. The dishwasher starts a 2-minute drain (if needed). Let the dishwasher drain completely.
	To follow progress of your dishwasher cycle.	If you select the Sani Rinse option, when the cycle is finished, the "Sanitized" indicator glows. If your dishwasher did not properly sanitize your dishes, the light flashes at the end of the cycle. This can happen if the cycle is interrupted or water could not be heated to required temperature. The light goes off when you open and close door or press CANCEL.

## Filtration System

Your dishwasher has the latest technology in dishwasher filtration. This triple filtration system minimizes sound and optimizes water and energy conservation while providing superior cleaning performance. Throughout the life of your dishwasher, the filter will require maintenance to sustain peak cleaning performance.

The triple filter system consists of 2 parts, an upper filter assembly and a lower filter.

- The upper filter assembly keeps oversized items and foreign objects, along with very fine food particles, out of the pump.
- The lower filter keeps food from being recirculated onto your dishwasher.

The filters may need to be cleaned when:

- Visible objects or soils are on the upper filter assembly.
- There is degradation in cleaning performance (that is, soils still present on dishes).
- Dishes feel gritty to the touch.

It is very easy to remove and maintain the filters. The chart below shows the recommended cleaning frequency.

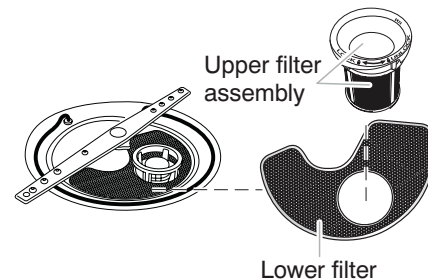

### RECOMMENDED TIME INTERVAL TO CLEAN YOUR FILTER

Number of Loads Per Week	If you only scrape before loading*	If you scrape and rinse before loading	If you wash before loading
8-12	Every two months	Every four months	Once per year
4-7	Every four months	Once per year	Once per year
1-3	Twice per year	Once per year	Once per year

\*Manufacturer's recommendation: This practice will conserve the water and energy that you would have used to prepare your dishes. This will also save you time and effort.

### Very Hard Water

If you have hard water (above 15 grains), clean your filter at least once per month. Building up of white residue on your dishwasher indicates hard water. For tips on removing spots and stains, see the "Troubleshooting" section.

## Filter Removal Instructions

1. Turn the upper filter assembly ¼ turn counterclockwise and lift out.
2. Separate the upper filter assembly by gently pulling apart.
3. Clean the filters as shown.

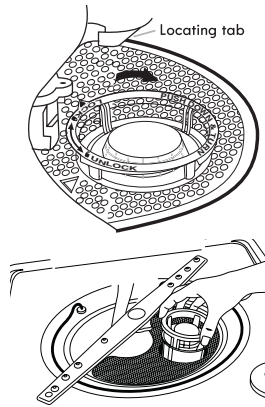

## Cleaning Instructions

**IMPORTANT:** Do not use wire brush, scouring pad, etc., as they may damage the filters.

Rinse filter under running water until most soils are removed. If you have hard-to-remove soils or calcium deposits from hard water, a soft brush may be required.

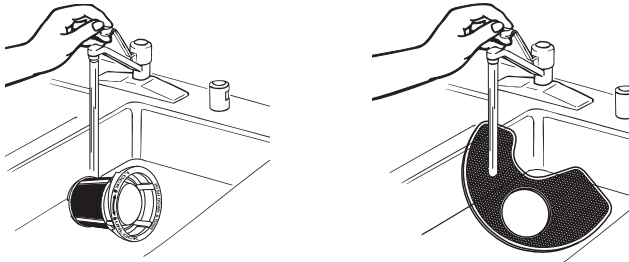

## Filter Reinstallation Instructions

1. Noting the previous illustrations, place the lower filter under the locating tabs in the bottom of the dishwasher so the round opening for the upper filter assembly lines up with the round opening in the bottom of the tub.
2. Insert the upper filter assembly into the circular opening in the lower filter.
3. Slowly rotate the filter clockwise until it drops into place. Continue to rotate until the filter is locked into place. If the filter is not fully seated (still turns freely), continue to turn the filter clockwise until it drops and locks into place.

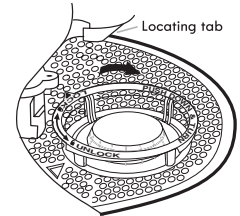
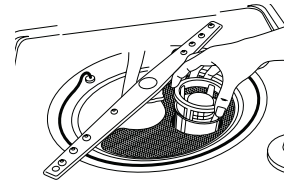

To replace upper filter assembly

**NOTE:** The upper filter assembly arrow does not have to align with the arrow in the lower filter as long as the filter is locked.

**IMPORTANT:** To avoid damage to dishwasher, do not operate your dishwasher without the filters properly installed. Be sure the lower filter is securely in place and the upper filter assembly is locked into place. If the upper filter assembly turns freely, it is not locked into place.

## Dishwasher Care

### CLEANING THE DISHWASHER

#### Cleaning the exterior

Clean the exterior of the dishwasher with a soft, damp cloth and mild detergent. If your dishwasher has a stainless steel exterior, a stainless steel cleaner is recommended - Stainless Steel Cleaner and Polish Part Number 31464.

#### Cleaning the interior

Clean the interior of the dishwasher with a paste of powdered dishwasher detergent and water, or use liquid dishwasher detergent on a damp sponge to clean the cooled-down interior. A white vinegar rinse may remove white spots and film. Vinegar is an acid, and using it too often could damage your dishwasher. Put 2 cups (500 mL) white vinegar in a glass or dishwasher-safe 2 cup capacity measuring cup on the bottom rack (do not pour). Run the dishwasher through a complete washing cycle using an air-dry or an energy-saving dry option. Do not use detergent. Vinegar will mix with the wash water.

#### Dishwasher Maintenance Procedure

**Removal of Hard Water/Filming:** Recommended use of a monthly maintenance product such as affresh®† Dishwasher Cleaner Part Number W10282479.

- Load your dishwasher (preferably with dishes affected by filming/hard water).
- Place tablet in main wash compartment of detergent dispenser.
- Select cycle/option best for heavily soiled dishes and start dishwasher.

**NOTE:** Using a premeasured detergent tablet or pack for regular daily use is recommended.

#### To Reduce Risk of Property Damage During Vacation or Extended Time Without Use

- When you will not be using the dishwasher during the summer months, turn off the water and power supply to the dishwasher.
- Make sure the water supply lines are protected against freezing conditions. Ice formations in the supply lines can increase water pressure and cause damage to your dishwasher or home. Damage from freezing is not covered by the warranty.
- When storing your dishwasher in the winter, avoid water damage by having your dishwasher winterized by authorized service personnel.

#### Drain air gap

If you have a drain air gap, check and clean it if the dishwasher isn't draining well.

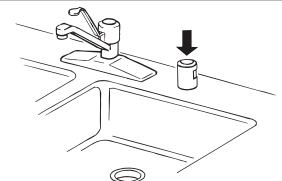

†affresh® is a registered trademark of Whirlpool, U.S.A. Used with permission.

## Troubleshooting

**First try the solutions suggested here or visit our website and reference FAQs (Frequently Asked Questions) to possibly avoid the cost of a service call.**

In the U.S.A., [www.ikea.com](http://www.ikea.com) In Canada, [www.ikea.com](http://www.ikea.com)

### DISHWASHER IS NOT OPERATING PROPERLY

PROBLEM	POSSIBLE CAUSES AND/OR SOLUTIONS
Dishwasher does not run or stops during a cycle	Is the door closed tightly and latched? Is the right cycle selected? Is there power to the dishwasher? Has a household fuse blown or has a circuit breaker tripped? Replace the fuse or reset the circuit breaker. If the problem continues, call an electrician. Has the motor stopped due to an overload? The motor automatically resets itself within a few minutes. If it does not restart, call for service. Is the water shut-off valve (if installed) turned on? It is normal for certain cycles to repeatedly pause for several seconds during the main wash.
The Clean light is flashing	Call for service.
Dishwasher will not fill	Is the overflow protection float able to move up and down freely? Press down to release. 
Dishwasher seems to run too long	The dishwasher can run up to 3½ hours depending on soil level, water temperature, cycles, and options. Is the water supplied to the dishwasher hot enough? The dishwasher runs longer while heating water. Is the dishwasher cycle time within the cycle times? See cycle selections wash times. A delay automatically occurs in some wash and rinse cycles until the water reaches the proper temperature. This dishwasher is equipped with an optical sensor wash that detects water temperature, soil, and detergent amount. Wash cycles are adjusted based on what is sensed. <b>IMPORTANT:</b> The very first wash cycle after installation in your home will be adjusted to include an additional 2 rinses. This cycle must not be interrupted for proper sensor adjustment. If this adjustment cycle is canceled or stopped before the Clean light comes on at the end of the cycle, the next wash cycle will repeat this sensor adjustment.
Water remains in the dishwasher	Is the cycle complete?
Detergent remains in the covered section of the dispenser	Is the cycle complete? Is the detergent lump free? Replace detergent if necessary. Is the dispenser door blocked by dishes or cookware when the dishwasher door is closed?
White residue on the front of the access panel	Was too much detergent used? Is the brand of detergent making excess foam? Try a different brand to reduce foaming and eliminate buildup.
Odor in the dishwasher	Are dishes washed only every 2 or 3 days? Run a rinse cycle once or twice a day until you have a full load. Does the dishwasher have a new plastic smell? Run a vinegar rinse as described in "Dishwasher Care."
Condensation on the kitchen counter (built-in models)	Is the dishwasher aligned with the countertop? Moisture from the vent in the dishwasher console can form on the counter. Refer to the Installation Instructions for more information

### DISHES DO NOT DRY COMPLETELY

Dishes do not dry completely	Did you use a rinse aid? Your dishwasher is designed to use rinse aid for good drying performance. Without rinse aid, your dishes and dishwasher interior will have excessive moisture. The Heat Dry option will not perform as well without rinse aid.
Dishes are not dry	Did you load your dishwasher to allow proper water drainage? Do not overload. Use a liquid rinse aid to speed drying. Are the plastics wet? Plastics often need towel drying. Is the rinse aid dispenser empty? Did you use an air-dry or energy-saving dry option? Use a heated drying option for dryer dishes.
PROBLEM	POSSIBLE CAUSES AND/OR SOLUTIONS
Excess moisture on racks and dishwasher interior	Check the rinse aid indicator to see that there is rinse aid in the dispenser.



## SPOTS AND STAINS ON DISHES

<p><b>Spotting and filming on dishes</b></p>	<p>Is your water hard or is there a high mineral content in your water? Conditioning the final rinse water with a liquid rinse aid helps eliminate spotting and filming. Keep the rinse aid dispenser filled. Always use a high-temp option. If your water hardness is 13 grains or above, it is strongly recommended that you install a home water softener. If you do not wish to drink softened water, have the softener installed onto your hot water supply.</p> <p>Is the water temperature too low? For best dishwashing results, water should be 120°F (49°C) as it enters the dishwasher.</p> <p>Did you use the correct amount of effective detergent? Use recommended dishwasher detergents only. Do not use less than 1 tbs (15 g) per load. Detergent must be fresh to be effective. Heavy soil and/or hard water generally require extra detergent.</p> <p>Is the home water pressure high enough for proper dishwasher filling? Home water pressure should be 20 to 120 psi (138 to 828 kPa) for proper dishwasher fill. If you have questions about your water pressure, call a licensed, qualified plumber.</p> <p><b>NOTE:</b> To remove spots and film from glassware, remove all silverware and metal items and see “Dishwasher Maintenance Procedure” in the “Dishwasher Care” section.</p>
<p><b>Silica film or etching (silica film is a milky, rainbow-colored deposit; etching is a cloudy film)</b></p>	<p>Sometimes there is a water/chemical reaction with certain types of glassware. This is usually caused by some combination of soft or softened water, alkaline washing solutions, insufficient rinsing, overloading the dishwasher, and the heat of drying. It might not be possible to avoid the problem, except by hand-washing.</p> <p>To slow this process, use a minimum amount of detergent but not less than 1 tbs (15 g) per load. Use a liquid rinse aid and underload the dishwasher to allow thorough rinsing. Silica film and etching are permanent and cannot be removed. Do not use heated drying.</p>
<p><b>White spots on cookware with nonstick finish</b></p>	<p>Has the dishwasher detergent removed cookware seasoning? Reseason cookware after washing it in the dishwasher.</p>
<p><b>Brown stains on dishes and dishwasher interior</b></p>	<p>Does your water have high iron content? Rewash dishes using 1-3 tsp (5-15 mL) of citric acid crystals added to the covered section of the detergent dispenser. Do not use detergent.</p> <p>Follow with a Normal wash cycle with detergent. If treatment is needed more often than every other month, the installation of an iron removal unit is suggested.</p>
<p><b>Black or gray marks on dishes</b></p>	<p>Are aluminum items rubbing dishes during washing? Disposable aluminum items can break down in the dishwasher and cause marking. Hand wash these items. Remove aluminum markings by using a mild abrasive cleaner</p>
<p><b>Orange stains on plastic dishes or dishwasher interior</b></p>	<p>Are large amounts of tomato-based foods on dishes placed in the dishwasher? It may be necessary to use a stain removal product to remove stains from your dishwasher. Stains will not affect dishwasher performance.</p>

## NOISES

<p><b>Grinding, grating, crunching, or buzzing sounds</b></p>	<p>A hard object has entered the wash module (on some models). When the object is ground up, the sound should stop. If the noise persists after a complete cycle, call for service.</p>
---	---

## DISHES ARE NOT COMPLETELY CLEAN

<p><b>Food soil left on the dishes</b></p>	<p>Is the dishwasher loaded correctly? Did you choose the cycle that describes the most difficult soil in your dishwasher? If you have some items with heavier soils, use a heavier cycle. Is the water temperature too low? For best dishwashing results, water should be 120°F (49°C) as it enters the dishwasher. Did you use the correct amount of fresh detergent? Use recommended dishwasher detergents only. Do not use less than 1 tbs (15 g) per load. Detergent must be fresh to be effective. Heavy soil and/or hard water generally require extra detergent.</p> <p>Is detergent caked in dispenser? Use fresh detergent only. Do not allow detergent to sit for several hours in a wet dispenser. Clean dispenser when caked detergent is present.</p> <p>Is the pump or spray arm clogged by labels from bottles and cans? Is the home water pressure high enough for proper dishwasher filling? Home water pressure should be 20 to 120 psi (138 to 828 kPa) for proper dishwasher fill. If you have questions about your water pressure, call a licensed, qualified plumber.</p> <p>Are high suds slowing the wash arm? Do not use soap or laundry detergents. Use recommended dishwasher detergents only.</p>
--	--



---

**DISHES ARE DAMAGED DURING A CYCLE**

<b>PROBLEM</b>	<b>POSSIBLE CAUSES AND/OR SOLUTIONS</b>
<b>Chipping of dishes</b>	Did you load the dishwasher properly? Load the dishes and glasses so they are stable and do not strike together from washing action. Minimize chipping by moving the rack in and out slowly. <b>NOTE:</b> Antiques, feather-edged crystal, and similar types of china and glassware might be too delicate for automatic dishwashing. Wash by hand.