

PRO-FORM[®]

475 E

Model No. 831.23935.3

Serial No. _____

Write the serial number in the space above for reference.

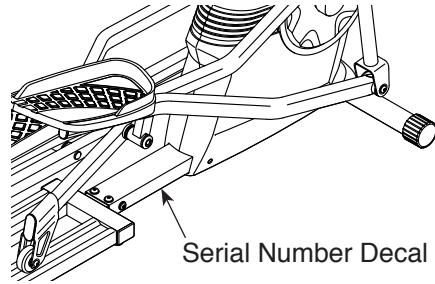

- Assembly
- Operation
- Maintenance
- Part List and Drawing

Sears, Roebuck and Co.
Hoffman Estates, IL 60179

CAUTION

Read all precautions and instructions in this manual before using this equipment. Keep this manual for future reference.

ELLIPTICAL EXERCISER

User's Manual

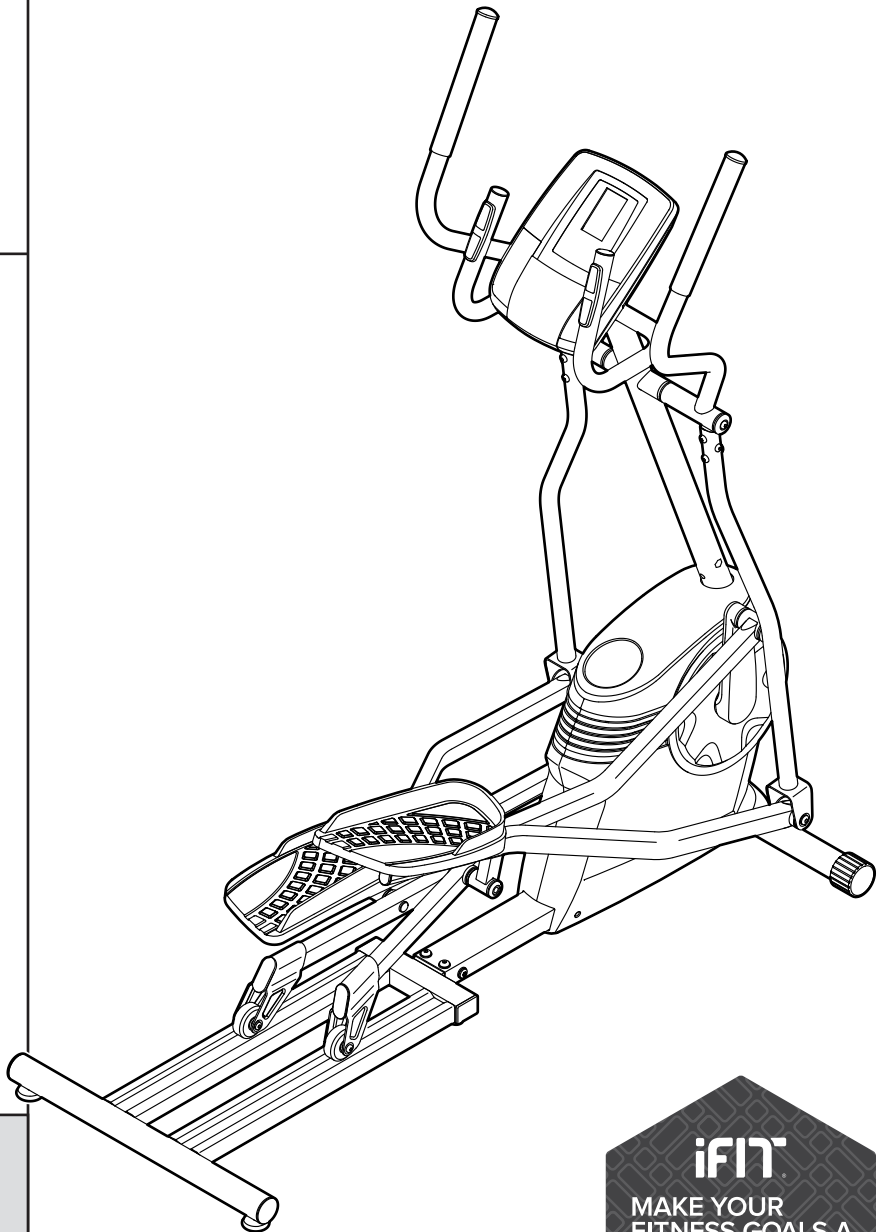

TABLE OF CONTENTS

WARNING DECAL PLACEMENT 2

IMPORTANT PRECAUTIONS..... 3

BEFORE YOU BEGIN..... 4

PART IDENTIFICATION CHART..... 5

ASSEMBLY..... 6

HOW TO USE THE ELLIPTICAL..... 13

FCC INFORMATION..... 17

MAINTENANCE AND TROUBLESHOOTING..... 18

EXERCISE GUIDELINES..... 20

PART LIST..... 21

EXPLODED DRAWING..... 22

ORDERING REPLACEMENT PARTS..... Back Cover

90 DAY FULL WARRANTY..... Back Cover

WARNING DECAL PLACEMENT

This drawing shows the location(s) of the warning decal(s). **If a decal is missing or illegible, call 1-888-533-1333 and request a free replacement decal. Apply the decal in the location shown.**
 Note: The decal(s) may not be shown at actual size.

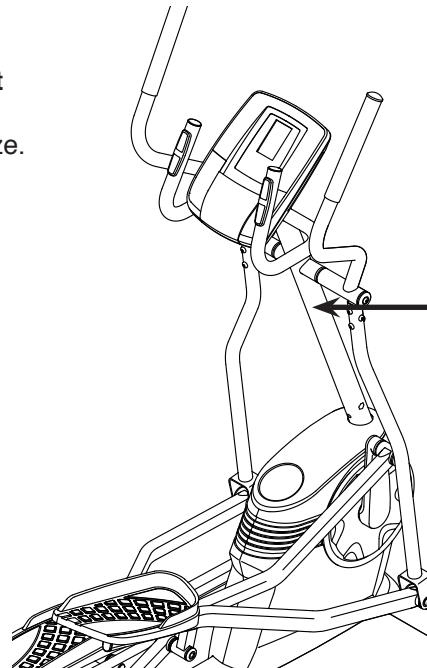

⚠ WARNING

- Misuse of this machine may result in serious injury.
- Read user's manual prior to use and follow all warnings and instructions.
- Do not allow children on or around machine.
- Pedals continue to spin when you stop pedaling.
- Spinning pedals can cause injury.
- Reduce pedal speed in a controlled manner.
- User weight must not exceed 250 lbs / 113 kgs.
- This product should always be used on a level surface.
- This product is not intended for therapeutic use.
- Replace label if damaged, illegible, or removed.



IMPORTANT PRECAUTIONS

⚠️ WARNING: To reduce the risk of serious injury, read all important precautions and instructions in this manual and all warnings on your elliptical before using your elliptical. Sears assumes no responsibility for personal injury or property damage sustained by or through the use of this product.

1. It is the responsibility of the owner to ensure that all users of the elliptical are adequately informed of all precautions.
2. Before beginning any exercise program, consult your physician. This is especially important for persons over age 35 or persons with pre-existing health problems.
3. The elliptical is not intended for use by persons with reduced physical, sensory, or mental capabilities or lack of experience and knowledge, unless they are given supervision or instruction about use of the elliptical by someone responsible for their safety.
4. Use the elliptical only as described in this manual.
5. The elliptical is intended for home use only. Do not use the elliptical in a commercial, rental, or institutional setting.
6. Keep the elliptical indoors, away from moisture and dust. Do not put the elliptical in a garage or covered patio, or near water.
7. Place the elliptical on a level surface, with at least 3 ft. (0.9 m) of clearance in the front and rear of the elliptical and 2 ft. (0.6 m) on each side. To protect the floor or carpet from damage, place a mat under the elliptical.
8. Inspect and properly tighten all parts each time the elliptical is used. Replace any worn parts immediately.
9. Keep children under age 13 and pets away from the elliptical at all times.
10. The elliptical should not be used by persons weighing more than 250 lbs. (113 kg).
11. Wear appropriate clothes while exercising; do not wear loose clothes that could become caught on the elliptical. Always wear athletic shoes for foot protection while exercising.
12. Hold the handlebars or the upper body arms when mounting, dismounting, or using the elliptical.
13. The heart rate monitor is not a medical device. Various factors may affect the accuracy of heart rate readings. The heart rate monitor is intended only as an exercise aid in determining heart rate trends in general.
14. The elliptical does not have a freewheel; the pedals will continue to move until the flywheel stops. Reduce your pedaling speed in a controlled way.
15. Keep your back straight while using the elliptical; do not arch your back.
16. Over exercising may result in serious injury or death. If you feel faint, if you become short of breath, or if you experience pain while exercising, stop immediately and cool down.

BEFORE YOU BEGIN

Thank you for selecting the revolutionary PROFORM® 475 E elliptical. The 475 E elliptical provides an impressive selection of features designed to make your workouts at home more effective and enjoyable.

For your benefit, read this manual carefully before you use the elliptical. If you have questions after reading this manual, please see the back cover of this

manual. To help us assist you, note the product model number and serial number before contacting us. The model number and the location of the serial number decal are shown on the front cover of this manual.

Before reading further, please familiarize yourself with the parts that are labeled in the drawing below.

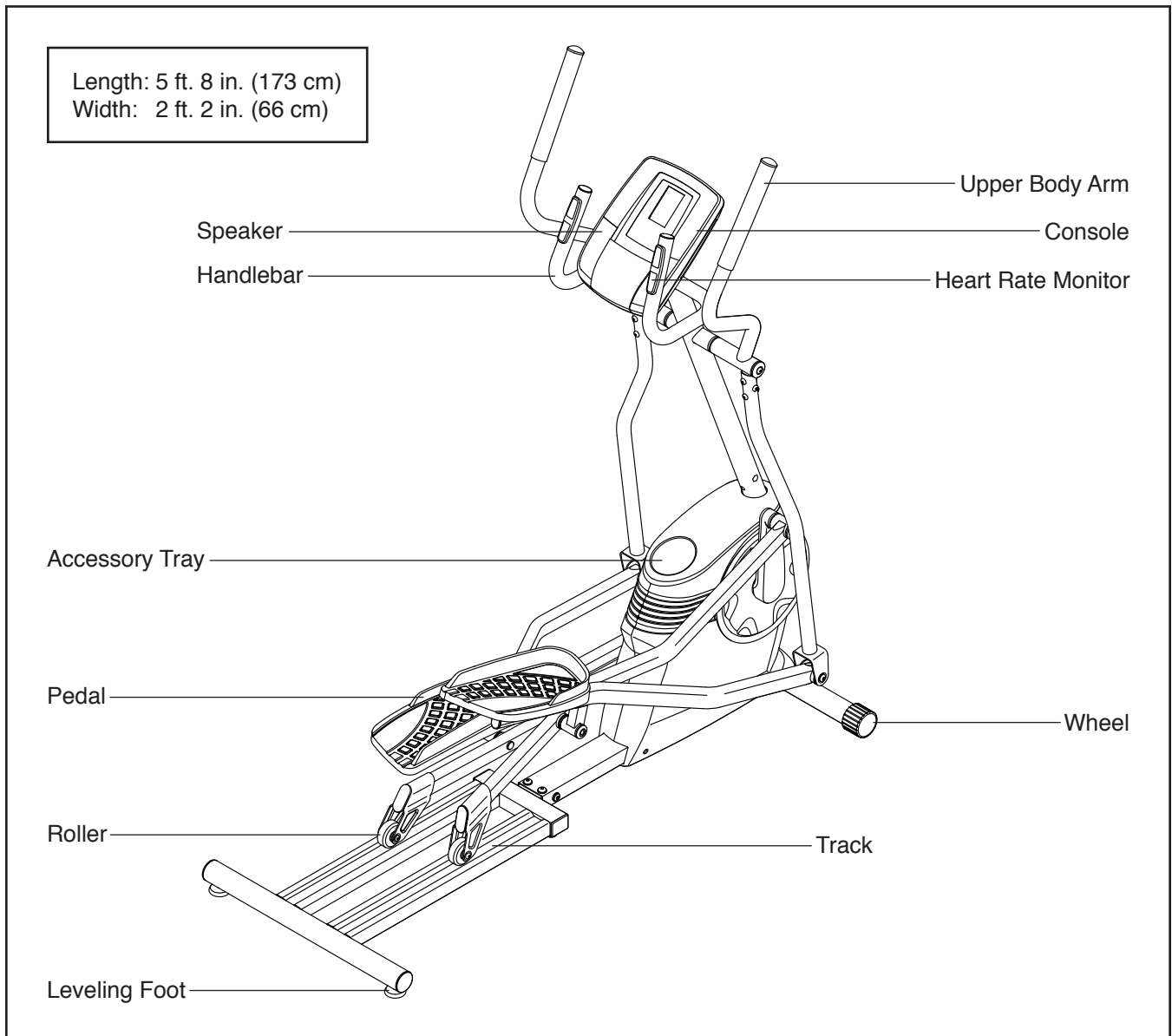

PART IDENTIFICATION CHART

Use the drawings below to identify the small parts needed for assembly. The number in parentheses below each drawing is the key number of the part, from the PART LIST near the end of this manual. The number following the key number is the quantity needed for assembly. **Note: If a part is not in the hardware kit, check to see if it has been preassembled. Extra parts may be included. If a part is missing, please call 1-888-533-1333.**

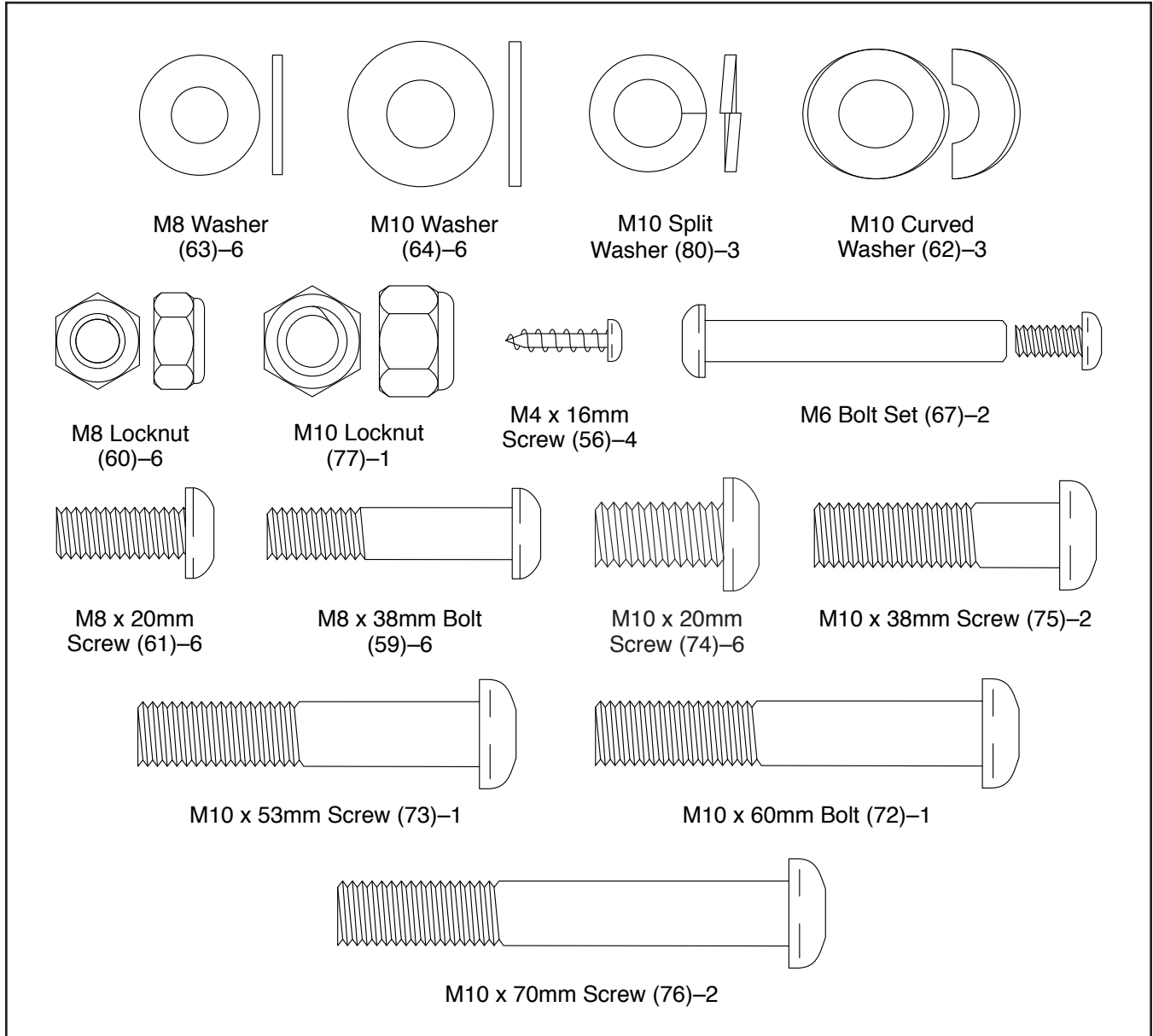

ASSEMBLY

- Assembly requires two persons.
- Place all parts in a cleared area and remove the packing materials. Do not dispose of the packing materials until you finish all assembly steps.
- Left parts are marked “L” or “Left” and right parts are marked “R” or “Right.”
- To identify small parts, see page 5.

- In addition to the included tool(s), assembly requires the following tools:

one Phillips screwdriver

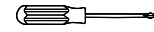

Assembly may be easier if you have a set of wrenches. To avoid damaging parts, do not use power tools.

1. Go to my.proform.com on your computer and register your product.

- activates your warranty
- saves you time if you ever need to contact Customer Care
- allows us to notify you of upgrades and offers

Note: If you do not have internet access, call 1-888-533-1333 and register your product.

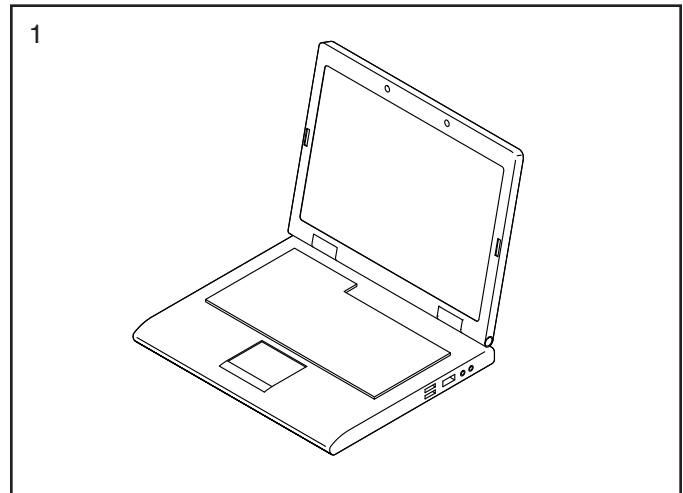

2. With the help of a second person, place some of the packing materials (not shown) under the front of the Frame (1). **Have the second person hold the Frame to prevent it from tipping while you complete this step.**

Attach the Front Stabilizer (12) to the Frame (1) with two M10 x 70mm Screws (76).

Remove the packing materials from under the Frame (1).

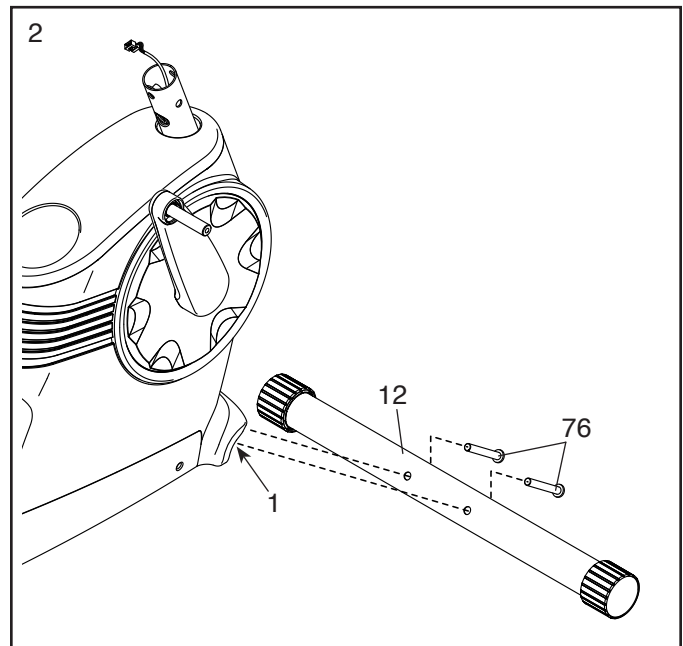

3. With the help of a second person, place some of the packing materials (not shown) under the rear of the Frame (1).

Attach the Track (11) to the Frame (1) with four M10 x 20mm Screws (74), two M10 x 38mm Screws (75), and six M10 Washers (64) as shown; **start all six Screws, and then tighten them.**

Remove the packing materials from under the Frame (1).

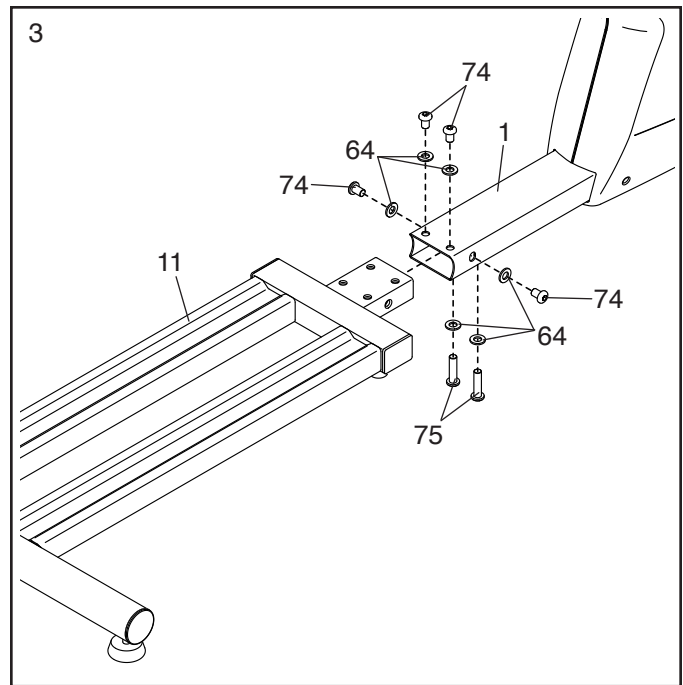

4. Have a second person hold the Upright (2) near the Frame (1).

Locate the wire tie (A) in the Upright (2). Tie the lower end of the wire tie to the Main Wire (32). Then, pull the upper end of the wire tie until the Main Wire is routed through the Upright.

Tip: Secure the Main Wire (32) to the Upright (2) with the wire tie (A) to prevent it from falling into the Upright.

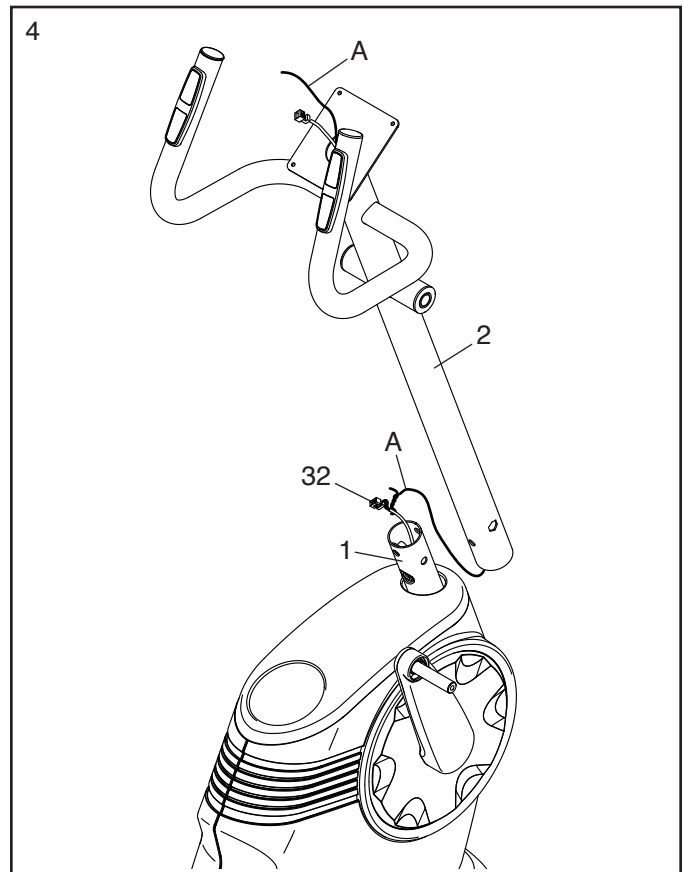

5. **Tip: Avoid pinching the Main Wire (32).** Slide the Upright (2) onto the Frame (1).

Attach the Upright (2) with an M10 x 53mm Screw (73), two M10 x 20mm Screws (74), three M10 Split Washers (80), and three M10 Curved Washers (62) as shown; **do not fully tighten the Screws yet.**

Finish attaching the Upright (2) with an M10 x 60mm Bolt (72) and an M10 Locknut (77); **do not fully tighten the Bolt yet. Make sure that the Locknut is in the hexagonal hole (B).**

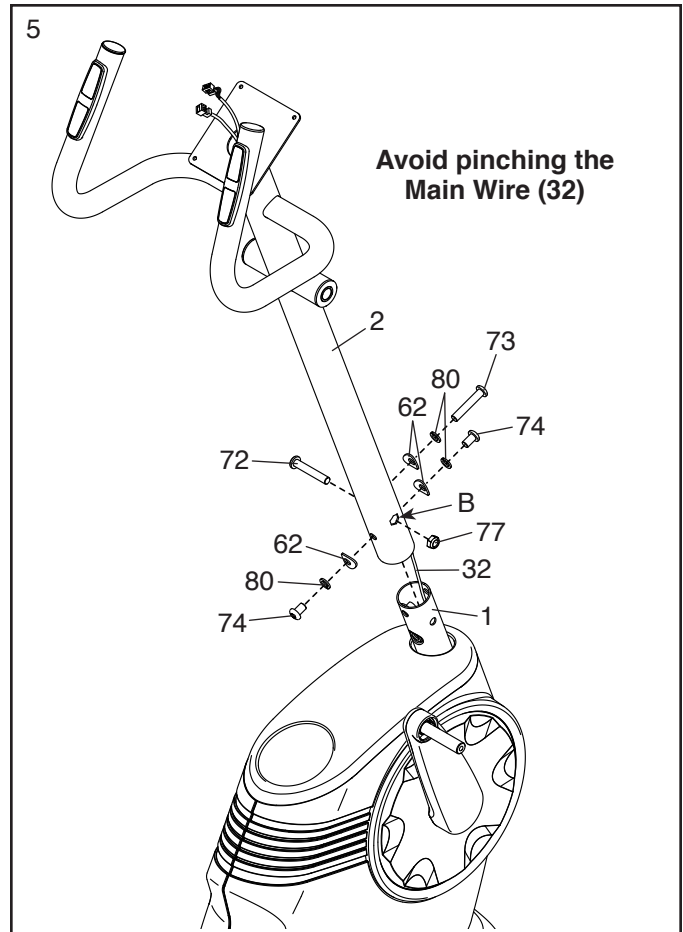

6. Insert the Upright Axle (18) into the Upright (2) and center it.

Using a plastic bag to keep your fingers clean, apply some of the included grease to both ends of the Upright Axle (18).

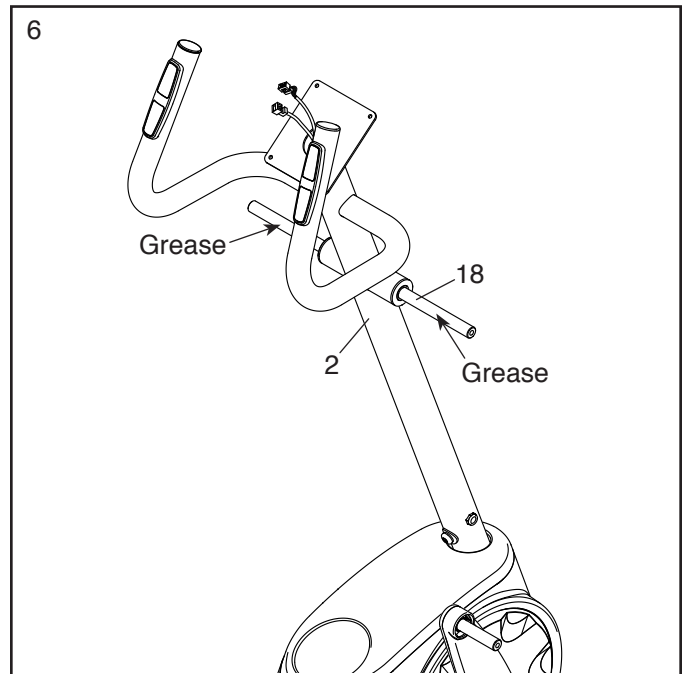

7. Identify the Right Upper Body Arm (4) and the Right Upper Body Leg (5), and orient them as shown.

Insert the Right Upper Body Arm (4) into the Right Upper Body Leg (5). Attach the Right Upper Body Arm with three M8 x 38mm Bolts (59) and three M8 Locknuts (60); **make sure that the Locknuts are in the hexagonal holes (C).** Do not fully tighten the Bolts yet.

Attach the Left Upper Body Arm (3) to the Left Upper Body Leg (6) in the same way.

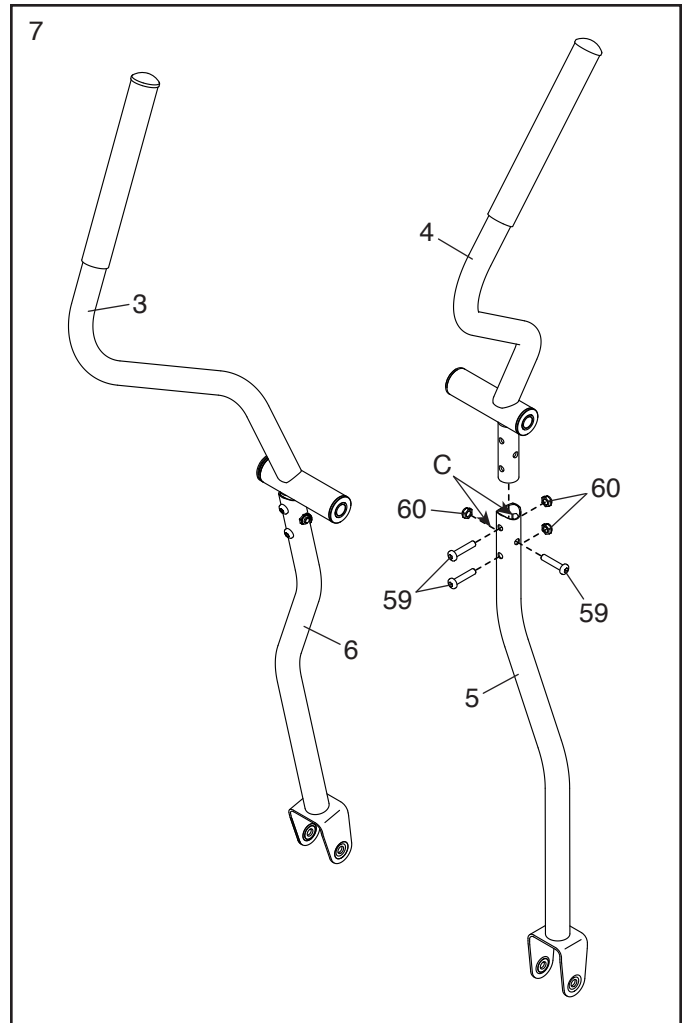

8. Slide the Right Upper Body Arm (4) onto the right side of the Upright Axle (18).

Slide the Left Upper Body Arm (3) onto the left side of the Upright Axle (18).

Tighten an M8 x 20mm Screw (61) with an Axle Cover (44) and an M8 Washer (63) into each end of the Upright Axle (18) **at the same time.**

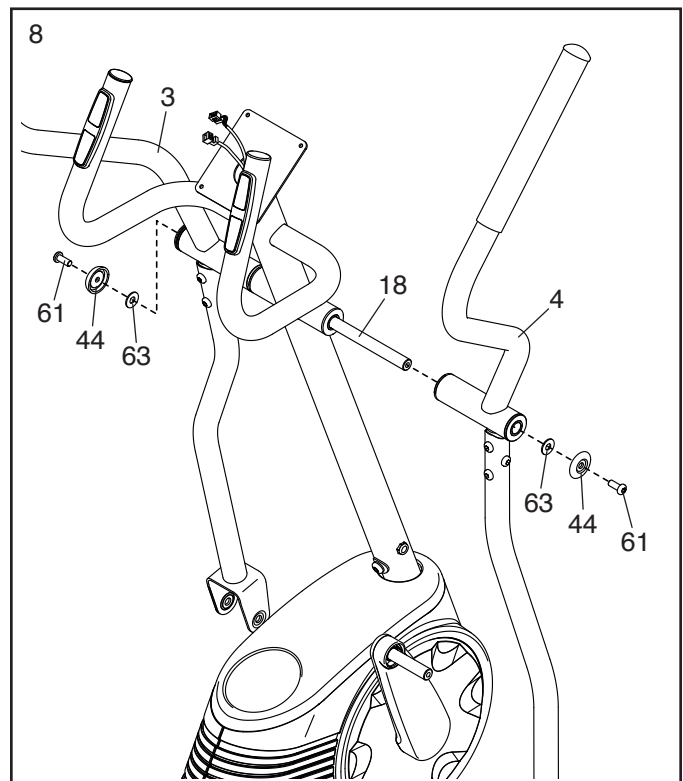

9. Apply grease to the right Crank Arm (13).

Identify the Right Roller Arm (7) and orient it as shown.

Attach the Right Roller Arm (7) to the right Crank Arm (13) with an M8 x 20mm Screw (61), an Axle Cover (44), and an M8 Washer (63).

Attach the Left Roller Arm (8) in the same way.

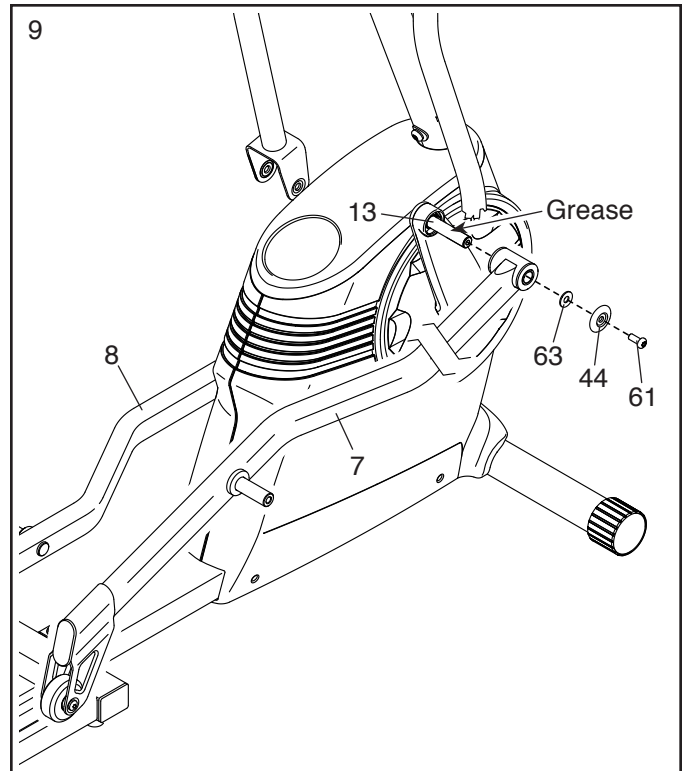

10. Apply grease to axle on the Right Roller Arm (7).

Then, identify the Right Pedal Arm (9), orient it as shown, and slide it onto the Right Roller Arm (7).

Attach the Right Pedal Arm (9) with an M8 x 20mm Screw (61), an Axle Cover (44), and an M8 Washer (63).

Attach the Left Pedal Arm (10) to the Left Roller Arm (8) in the same way.

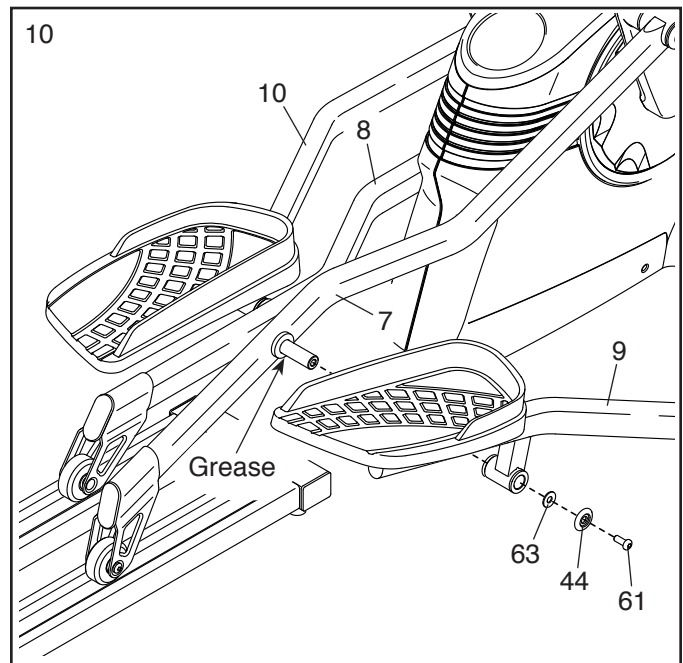

11. Apply grease to an M6 Bolt Set (67).

Attach the Right Pedal Arm (9) to the Right Upper Body Leg (5) with the M6 Bolt Set (67).

Attach the Left Pedal Arm (10) to the Left Upper Body Leg (6) in the same way.

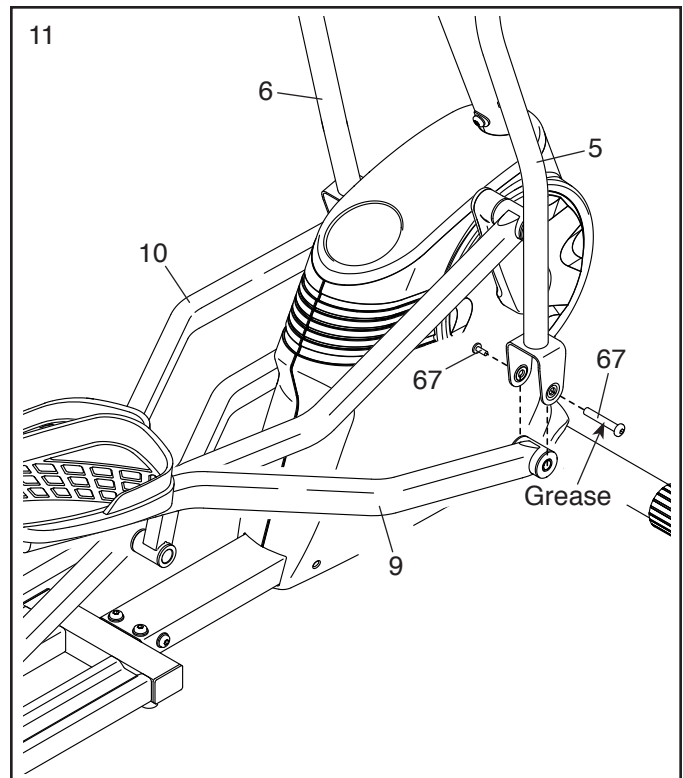

12. The Console (30) can use four D batteries (not included); alkaline batteries are recommended. Do not use old and new batteries together or alkaline, standard, and rechargeable batteries together. **IMPORTANT: If the Console has been exposed to cold temperatures, allow it to warm to room temperature before you insert batteries. Otherwise, you may damage the console displays or other electronic components.** Remove the battery covers (D) from the back of the Console, and insert batteries into the battery compartments. **Make sure to orient the batteries as shown by the diagrams inside the battery compartments.** Then, reattach the battery covers.

To purchase an optional power adapter, call the telephone number on the cover of this manual. To avoid damaging the console, use only a manufacturer-supplied regulated power adapter. Plug one end of the power adapter into the receptacle (E) inside the battery compartment on the console; plug the other end into an outlet installed in accordance with all local codes and ordinances.

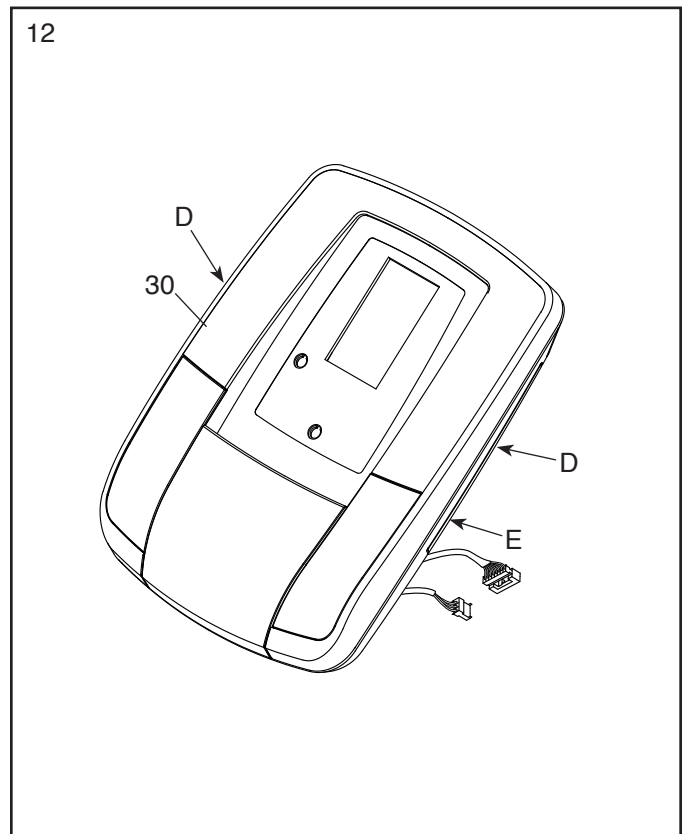

13. Remove and discard the wire tie on the Main Wire (32).

Have a second person hold the Console (30) near the Upright (2).

Connect the wires on the Console (30) to the Main Wire (32) and to the Pulse Wire (31).

Insert the excess wire into the Upright (2).

Tip: Avoid pinching the wires. Attach the Console (30) to the Upright (2) with four M4 x 16mm Screws (56); **start all the Screws, and then tighten them.**

See step 5. Tighten the M10 x 53mm Screw (73), the M10 x 20mm Screws (74), and the M10 x 60mm Bolt (72).

See step 7. Tighten the M8 x 38mm Bolts (59).

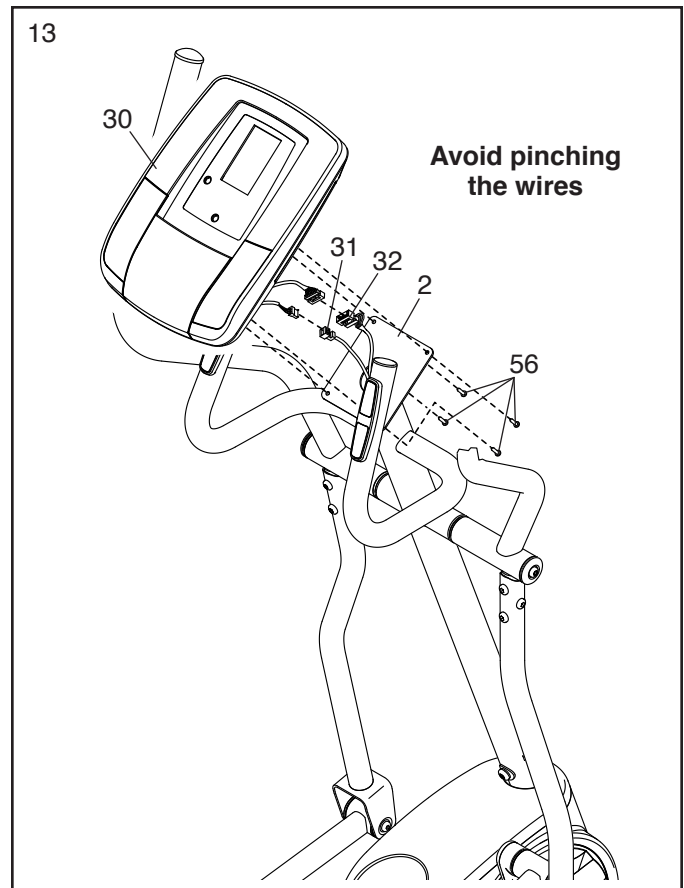

14. **Make sure that all parts are properly tightened before you use the elliptical.** Extra parts may be included. Place a mat beneath the elliptical to protect the floor.

HOW TO USE THE ELLIPTICAL

HOW TO MOVE THE ELLIPTICAL

Due to the size and weight of the elliptical, moving it requires two persons. Stand in front of the elliptical, hold the upright (A), and place one foot against one of the wheels (B). Pull on the upright, and have a second person lift the track (C) until the elliptical will roll on the wheels. Carefully move the elliptical to the desired location, and then lower it to the floor.

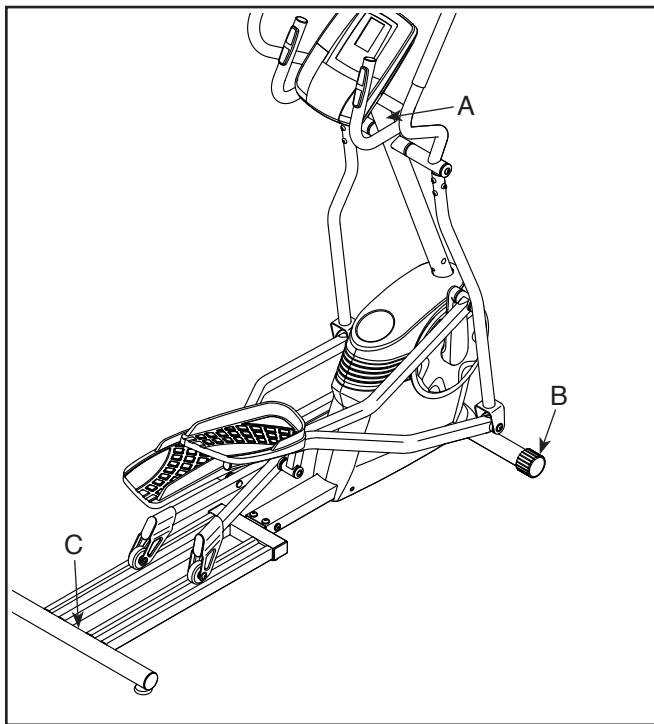

HOW TO EXERCISE ON THE ELLIPTICAL

To mount the elliptical, hold the handlebars (E) or the upper body arms (F) and step onto the pedal (G) that is in the lower position. Then, step onto the other pedal. Push the pedals until they begin to move with a continuous motion. **Note: The pedals can turn in either direction. It is recommended that you turn the pedals in the direction shown by the arrow; however, for variety, you can turn the pedals in the opposite direction.**

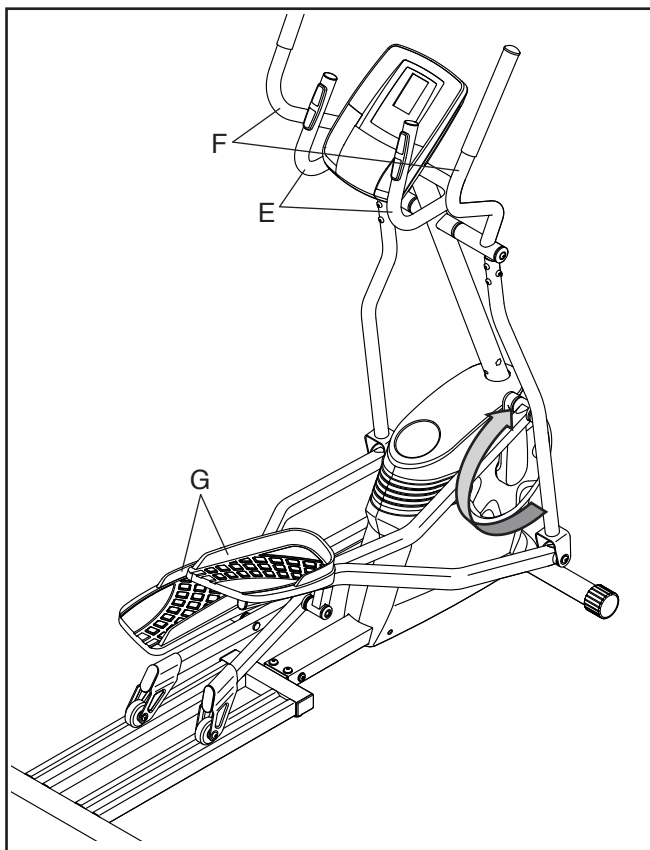

HOW TO LEVEL THE ELLIPTICAL

If the elliptical rocks slightly on your floor during use, turn one or both of the leveling feet (D) beneath the rear of the frame until the rocking motion is eliminated.

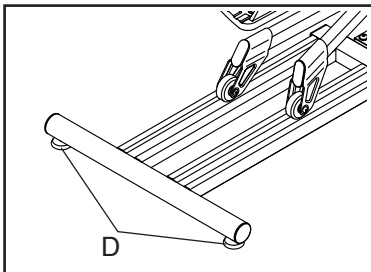

To dismount the elliptical, wait until the pedals (G) come to a complete stop. **Note: The elliptical does not have a free wheel; the pedals will continue to move until the flywheel stops.** When the pedals are stationary, step off the higher pedal first. Then, step off the lower pedal.

CONSOLE DIAGRAM

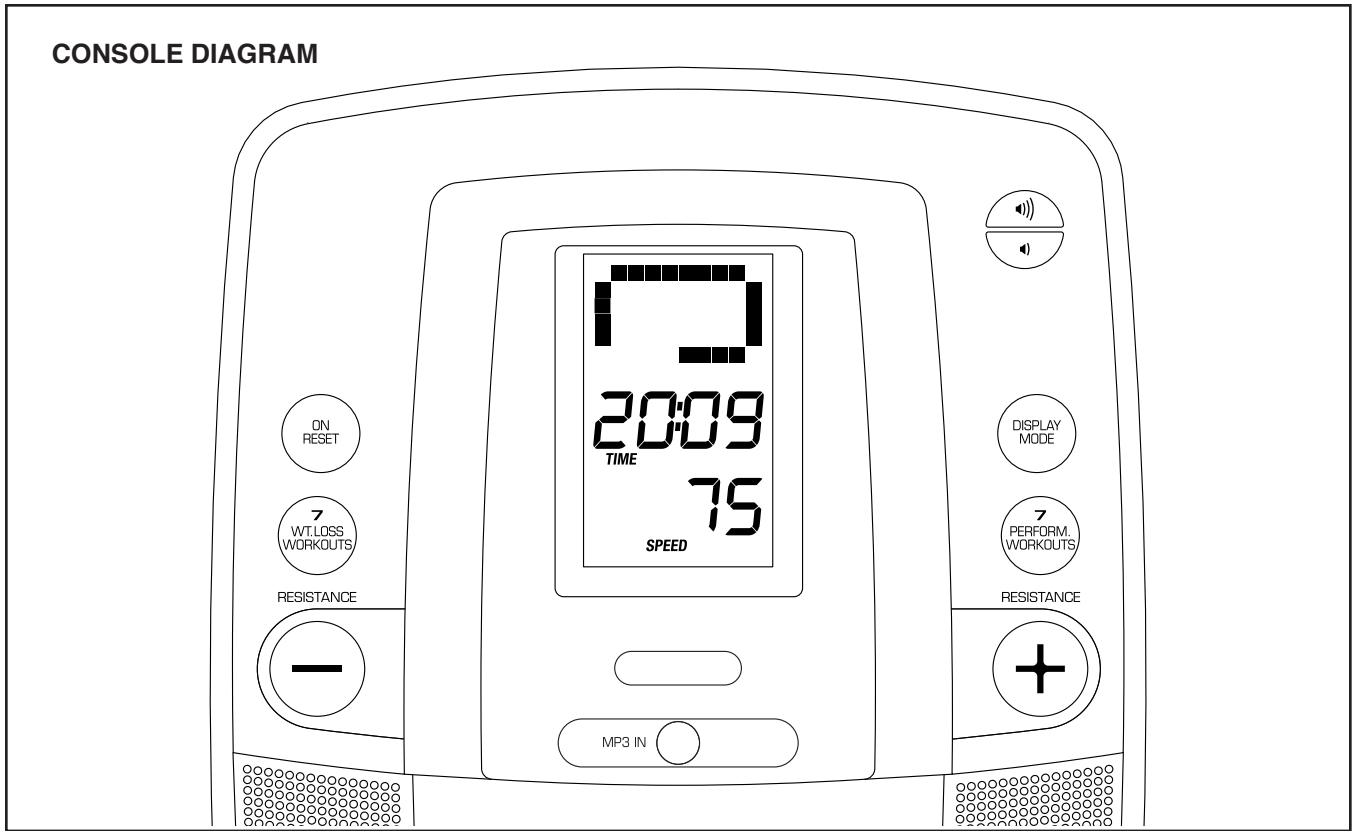

FEATURES OF THE CONSOLE

The advanced console offers an array of features designed to make your workouts more effective and enjoyable.

When you use the manual mode of the console, you can change the resistance of the pedals with the touch of a button.

As you exercise, the console will provide continuous exercise feedback. You can even measure your heart rate using the handgrip heart rate monitor.

The console offers a selection of preset workouts. Each preset workout automatically changes the

resistance of the pedals as it guides you through an effective workout.

You can even connect your personal audio player to the console sound system and listen to your favorite music or audio books while you exercise.

To use the manual mode, see page 15. **To use a preset workout**, see page 16. **To use the sound system**, see page 17.

Note: Make sure that batteries are installed in the console (see assembly step 12 on page 11). If there is a sheet of plastic on the display, remove the plastic.

HOW TO USE THE MANUAL MODE

1. Turn on the console.

Press any button or begin pedaling to turn on the console.

When you turn on the console, the display will turn on. A tone will sound and the console will be ready for use.

2. Select the manual mode.

When you turn on the console, the manual mode will be selected automatically.

If you have selected a workout, reselect the manual mode by pressing the Wt. Loss Workouts button or the Perform. Workouts button repeatedly until a track appears in the upper display.

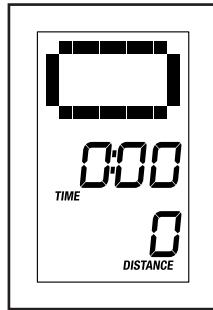

3. Begin pedaling and change the resistance of the pedals as desired.

As you pedal, change the resistance of the pedals by pressing the Resistance increase and decrease buttons.

Note: After you press the buttons, it will take a moment for the pedals to reach the selected resistance level.

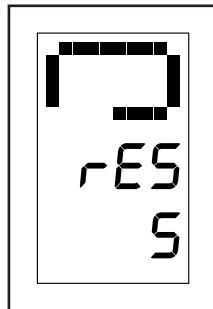

4. Follow your progress with the display.

The display can show the following workout information:

Calories—This display mode will show the approximate number of calories you have burned.

Distance—This display mode will show the distance that you have pedaled in revolutions.

Profile—When a workout is selected, this display mode will show a profile of the resistance settings of the workout.

Pulse—This display mode will show your heart rate when you use the handgrip heart rate monitor (see step 5).

Resistance (Res)—This display mode will show the resistance level of the pedals for a few seconds each time the resistance level changes.

Speed—This display mode will show your pedaling speed in revolutions per minute.

Time—When the manual mode is selected, this display mode will show the elapsed time. When a workout is selected, this display mode will show the time remaining in the workout.

Track—When the manual mode is selected, this display mode will show a track representing 1/4 mile (400 m). As you exercise, indicators will appear in succession around the track until the entire track appears. The track will then disappear and the indicators will again begin to appear in succession.

Press the Display Mode button repeatedly to view the desired workout information.

When the word SCAN appears in the display, the display will show the calories, distance, speed, and time display modes in a repeating cycle.

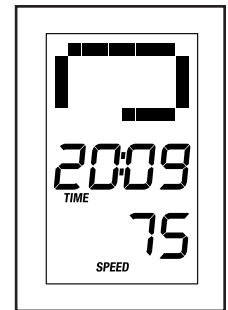

To reset the display to zero, press the On/Reset button.

Change the volume level of the console by pressing the volume increase and decrease buttons.

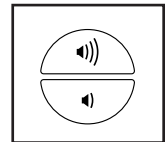

5. Measure your heart rate if desired.

If there are sheets of plastic on the metal contacts (A) on the handgrip heart rate monitor, remove the plastic. In addition, make sure that your hands are clean.

To measure your heart rate, hold the handgrip heart rate monitor with your palms resting against the contacts. **Avoid moving your hands or gripping the contacts tightly.**

When your pulse is detected, a heart-shaped symbol will flash in the display and then your heart rate will be shown. For the most accurate heart rate reading, hold the contacts for at least 15 seconds.

If your heart rate is not shown, make sure that your hands are positioned as described. Be careful not to move your hands excessively or to squeeze the contacts tightly. For optimal performance, clean the contacts using a soft cloth; **never use alcohol, abrasives, or chemicals to clean the contacts.**

6. When you are finished exercising, the console will turn off automatically.

If the pedals do not move for several seconds, a series of tones will sound, the console will pause, and the time will flash in the display.

If the pedals do not move for several minutes, the console will turn off and the display will be reset.

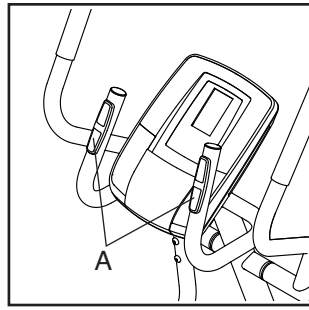

HOW TO USE A PRESET WORKOUT

1. Turn on the console.

Press any button or begin pedaling to turn on the console.

When you turn on the console, the display will turn on. A tone will sound and the console will be ready for use.

2. Select a preset workout.

To select a preset workout, press the Wt. Loss Workouts button or the Perform. Workouts button repeatedly until the number of the desired workout appears in the lower display.

When you select a preset workout, a profile (B) of the resistance levels of the workout will scroll across the upper display, the duration of the workout will appear in the center display, and the number of the workout will appear in the lower display.

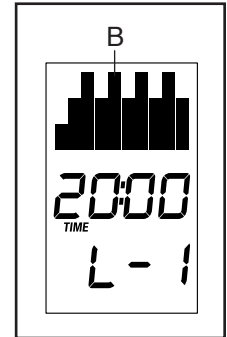

3. Begin pedaling to start the workout.

Each workout is divided into several one-minute segments. One resistance level is programmed for each segment. Note: The same resistance level may be programmed for consecutive segments.

During the workout, the workout profile will show your progress (see the drawing above). The flashing segment of the profile represents the current segment of the workout. The height of the flashing segment indicates the resistance level for the current segment.

At the end of each segment of the workout, a series of tones will sound and the next segment of the profile will begin to flash. If a different resistance level is programmed for the next segment, the resistance level will appear in the display for a few seconds to alert you. The resistance of the pedals will then change.

If the resistance level for the current segment is too high or too low, you can manually override the setting by pressing the Resistance buttons. However, when the current segment ends, the pedals will automatically adjust to the resistance level for the next segment.

If you stop pedaling for several seconds, a series of tones will sound and the workout will pause.

To resume the workout, simply resume pedaling. The workout will continue until the last segment of the profile flashes and the last segment of the workout ends.

4. Follow your progress with the display.

See step 4 on page 15.

5. Measure your heart rate if desired.

See step 5 on page 16.

6. When you are finished exercising, the console will turn off automatically.

See step 6 on page 16.

HOW TO USE THE SOUND SYSTEM

To play music or audio books through the console sound system while you exercise, plug a 3.5 mm male to 3.5 mm male audio cable (not included) into the jack on the console and into a jack on your personal audio player; **make sure that the audio cable is fully plugged in. Note: To purchase an audio cable, see your local electronics store.**

Next, press the play button on your personal audio player. Adjust the volume level using the volume increase and decrease buttons on the console or the volume control on your personal audio player.

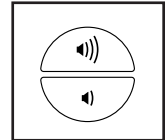

FCC INFORMATION

This equipment has been tested and found to comply with the limits for a Class B digital device, pursuant to part 15 of the FCC Rules. These limits are designed to provide reasonable protection against harmful interference in a residential installation. This equipment generates, uses, and can radiate radio frequency energy and, if not installed and used in accordance with the instructions, may cause harmful interference to radio communications. However, there is no guarantee that interference will not occur in a particular installation. If this equipment does cause harmful interference to radio or television reception, which can be determined by turning the equipment off and on, try to correct the interference by one or more of the following measures:

- Reorient or relocate the receiving antenna.
- Increase the separation between the equipment and the receiver.
- Connect the equipment into an outlet on a circuit different from that to which the receiver is connected.
- Consult the dealer or an experienced radio/TV technician for help.

FCC CAUTION: To assure continued compliance, use only shielded interface cables when connecting to computer or peripheral devices. Changes or modifications not expressly approved by the party responsible for compliance could void the user's authority to operate this equipment.

MAINTENANCE AND TROUBLESHOOTING

MAINTENANCE

Regular maintenance is important for optimal performance and to reduce wear. Inspect and properly tighten all parts each time the elliptical is used. Replace any worn parts immediately.

To clean the elliptical, use a damp cloth and a small amount of mild soap. **IMPORTANT: To avoid damage to the console, keep liquids away from the console and keep the console out of direct sunlight.**

CONSOLE TROUBLESHOOTING

Most console problems are the result of low batteries. To replace the batteries, see assembly step 12 on page 11.

If the console does not display your heart rate when you use the handgrip heart rate monitor, see step 5 on page 16.

HOW TO GREASE THE ROLLERS

If the Rollers (16) squeak when moving on the Track (11), apply a small amount of the included PTFE grease to a paper towel. Next, spread a thin layer of grease evenly along the Track where the Rollers move. Then, wipe off any excess grease.

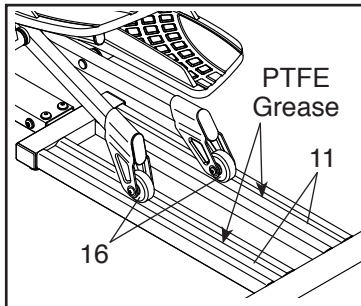

HOW TO ADJUST THE REED SWITCH

If the console does not display correct feedback, the reed switch should be adjusted.

To adjust the reed switch, first use a standard screwdriver and carefully pry the Accessory Tray (50) upward off the Right and Left Shields (48, 49).

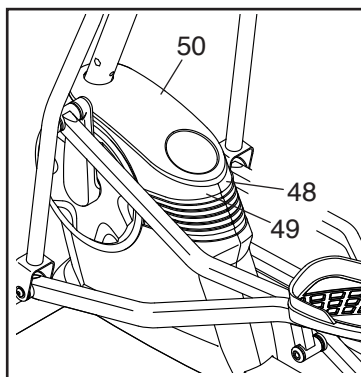

Next, locate the Reed Switch (33). Turn the Pulley (15) until a Magnet (65) is aligned with the Reed Switch.

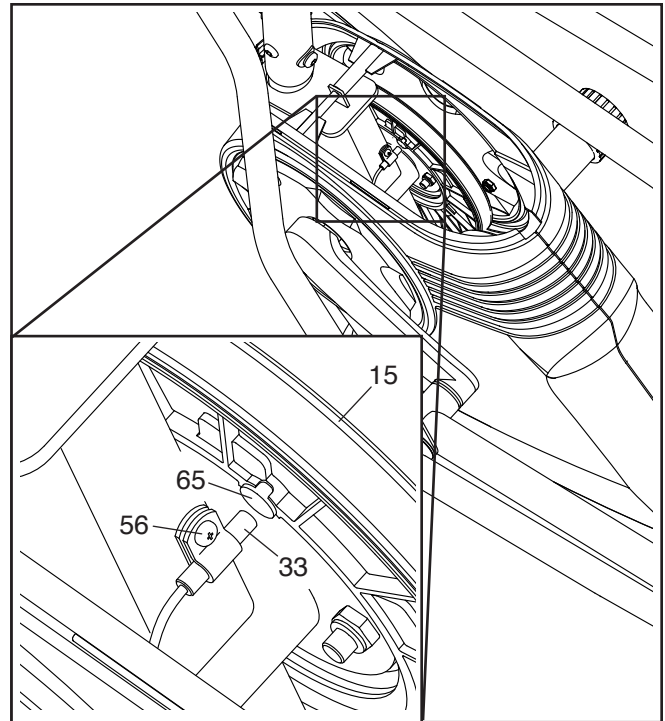

Slightly loosen the indicated M4 x 16mm Screw (56). Slide the Reed Switch (33) slightly closer to or away from the Magnet (65), and then retighten the Screw. Then, rock the Pulley (15) forward and backward just enough that the Magnet passes the Reed Switch repeatedly.

Repeat these actions until the console displays correct feedback. When the reed switch is correctly adjusted, reattach the accessory tray.

HOW TO ADJUST THE DRIVE BELT

If the pedals slip while you are pedaling, even while the resistance is adjusted to the highest level, the drive belt may need to be adjusted.

To adjust the drive belt, first use a standard screwdriver and carefully pry the Accessory Tray (50) upward off the Right and Left Shields (48, 49).

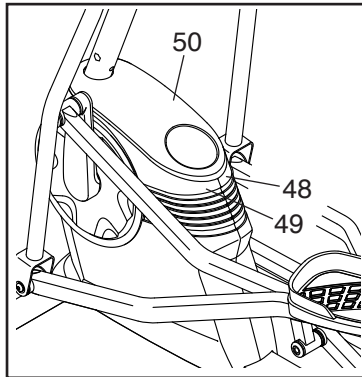

Next, remove the M6 Bolt Set (67) from the Right Upper Body Leg (5) and the Right Pedal Arm (9). Then, gently move the Right Pedal Arm out of the way.

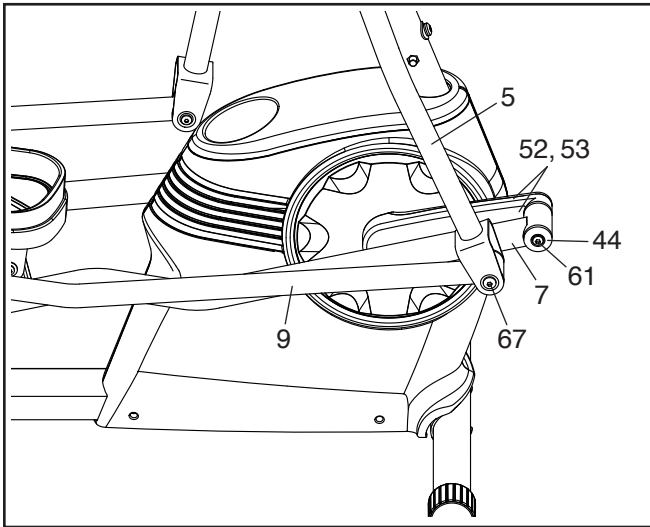

Next, remove the M8 x 20mm Screw (61), the Axle Cover (44), and the M8 Washer (not shown) from the Right Roller Arm (7) and the right Crank Arm (not shown). Gently move the Right Roller Arm out of the way. Then, use a standard screwdriver and gently remove the Outer and Inner Crank Covers (52, 53) from the right Crank Arm.

See **EXPLODED DRAWING A** on page 22. Locate the Right and Left Shields (48, 49). Then, remove the M4 x 25mm Screw (68) and the M4 x 19mm Screws (84) from the Right and Left Shields; **make sure to note the location of each Screw**. Then, gently remove the Right Shield.

Locate and loosen the M6 x 20mm Screw (25). Next, tighten the M10 x 55mm Screw (20) until the Drive Belt (55) is tight. Then, retighten the M6 x 20mm Screw.

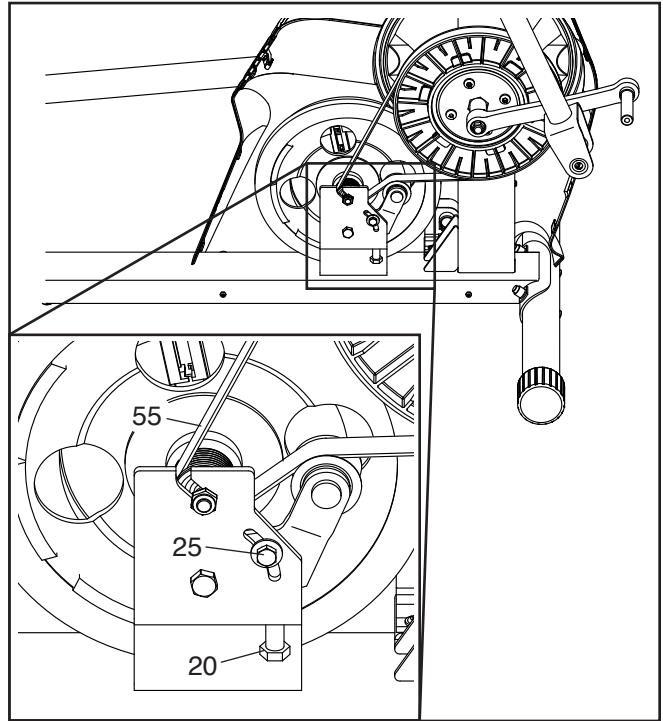

Reattach the right shield, the outer and inner crank covers, the right roller arm, the right pedal arm, and the accessory tray.

EXERCISE GUIDELINES

⚠️ WARNING: Before beginning this or any exercise program, consult your physician. This is especially important for persons over age 35 or persons with pre-existing health problems.

The heart rate monitor is not a medical device. Various factors may affect the accuracy of heart rate readings. The heart rate monitor is intended only as an exercise aid in determining heart rate trends in general.

These guidelines will help you to plan your exercise program. For detailed exercise information, obtain a reputable book or consult your physician. Remember, proper nutrition and adequate rest are essential for successful results.

EXERCISE INTENSITY

Whether your goal is to burn fat or to strengthen your cardiovascular system, exercising at the proper intensity is the key to achieving results. You can use your heart rate as a guide to find the proper intensity level. The chart below shows recommended heart rates for fat burning and aerobic exercise.

165	155	145	140	130	125	115	♥
145	138	130	125	118	110	103	♥
125	120	115	110	105	95	90	♥
<hr/>							
20	30	40	50	60	70	80	

To find the proper intensity level, find your age at the bottom of the chart (ages are rounded off to the nearest ten years). The three numbers listed above your age define your “training zone.” The lowest number is the heart rate for fat burning, the middle number is the heart rate for maximum fat burning, and the highest number is the heart rate for aerobic exercise.

Burning Fat—To burn fat effectively, you must exercise at a low intensity level for a sustained period of time. During the first few minutes of exercise, your body uses carbohydrate calories for energy. Only after the first few minutes of exercise does your body begin to use stored fat calories for energy. If your goal is to burn fat, adjust the intensity of your exercise until your heart rate is near the lowest number in your training zone. For maximum fat burning, exercise with your heart rate near the middle number in your training zone.

Aerobic Exercise—If your goal is to strengthen your cardiovascular system, you must perform aerobic exercise, which is activity that requires large amounts of oxygen for prolonged periods of time. For aerobic exercise, adjust the intensity of your exercise until your heart rate is near the highest number in your training zone.

WORKOUT GUIDELINES

Warming Up—Start with 5 to 10 minutes of stretching and light exercise. A warm-up increases your body temperature, heart rate, and circulation in preparation for exercise.

Training Zone Exercise—Exercise for 20 to 30 minutes with your heart rate in your training zone. (During the first few weeks of your exercise program, do not keep your heart rate in your training zone for longer than 20 minutes.) Breathe regularly and deeply as you exercise; never hold your breath.

Cooling Down—Finish with 5 to 10 minutes of stretching. Stretching increases the flexibility of your muscles and helps to prevent post-exercise problems.

EXERCISE FREQUENCY

To maintain or improve your condition, complete three workouts each week, with at least one day of rest between workouts. After a few months of regular exercise, you may complete up to five workouts each week, if desired. Remember, the key to success is to make exercise a regular and enjoyable part of your everyday life.

PART LIST

Model No. 831.23935.3 R0717A

Key No.	Qty.	Description	Key No.	Qty.	Description
1	1	Frame	45	2	Large Round Cap
2	1	Upright	46	1	Right Pedal
3	1	Left Upper Body Arm	47	1	Left Pedal
4	1	Right Upper Body Arm	48	1	Right Shield
5	1	Right Upper Body Leg	49	1	Left Shield
6	1	Left Upper Body Leg	50	1	Accessory Tray
7	1	Right Roller Arm	51	1	V-clip
8	1	Left Roller Arm	52	2	Outer Crank Cover
9	1	Right Pedal Arm	53	2	Inner Crank Cover
10	1	Left Pedal Arm	54	2	Angle Cap
11	1	Track	55	1	Drive Belt
12	1	Front Stabilizer	56	9	M4 x 16mm Screw
13	2	Crank Arm	57	4	M4 x 12mm Screw
14	1	Crank	58	1	M4 x 12mm Bright Screw
15	1	Pulley	59	6	M8 x 38mm Bolt
16	2	Roller	60	10	M8 Locknut
17	4	Small Roller Spacer	61	10	M8 x 20mm Screw
18	1	Upright Axle	62	3	M10 Curved Washer
19	4	Bushing C	63	6	M8 Washer
20	1	M10 x 55mm Screw	64	6	M10 Washer
21	3	Crank Spacer	65	2	Magnet
22	2	Pulse Sensor	66	2	5/16" x 25mm Screw
23	1	Eddy Mechanism	67	2	M6 Bolt Set
24	1	Idler	68	1	M4 x 25mm Screw
25	1	M6 x 20mm Screw	69	4	M8 Split Washer
26	1	M6 Washer	70	2	M5 Bolt Set
27	1	M6 x 20mm Shoulder Screw	71	1	Collar
28	2	M10 Nut	72	1	M10 x 60mm Bolt
29	1	Resistance Motor	73	1	M10 x 53mm Screw
30	1	Console	74	6	M10 x 20mm Screw
31	1	Pulse Wire	75	2	M10 x 38mm Screw
32	1	Main Wire	76	2	M10 x 70mm Screw
33	1	Reed Switch/Wire	77	1	M10 Locknut
34	2	Bearing	78	1	M5 x 10mm Screw
35	1	Clamp	79	10	#10 x 14mm Screw
36	4	Bushing A	80	3	M10 Split Washer
37	4	Bushing B	81	2	Track Cap
38	2	Leveling Foot	82	2	Pedal Arm Cap
39	2	Foot	83	6	Bushing D
40	2	Small Round Cap	84	4	M4 x 19mm Screw
41	2	Foam Grip	*	-	Assembly Tool
42	2	Dome Cap	*	-	Grease Packet
43	2	Wheel	*	-	User's Manual
44	6	Axle Cover			

Note: Specifications are subject to change without notice. For information about ordering replacement parts, see the back cover of this manual. **If a part is missing, call 1-888-533-1333.** *These parts are not illustrated.

EXPLODED DRAWING A

Model No. 831.23935.3 R0717A

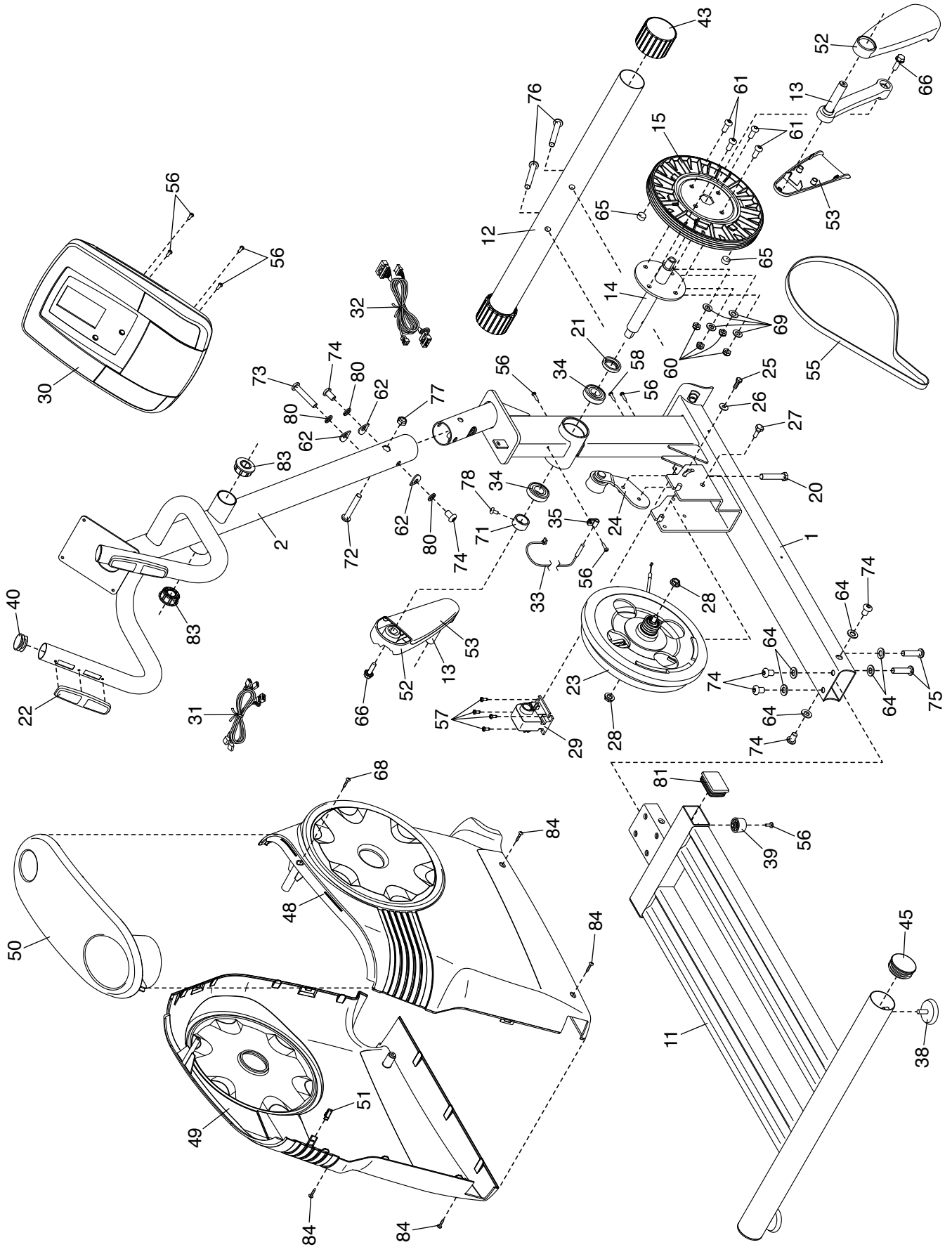

EXPLODED DRAWING B

Model No. 831.23935.3 R0717A

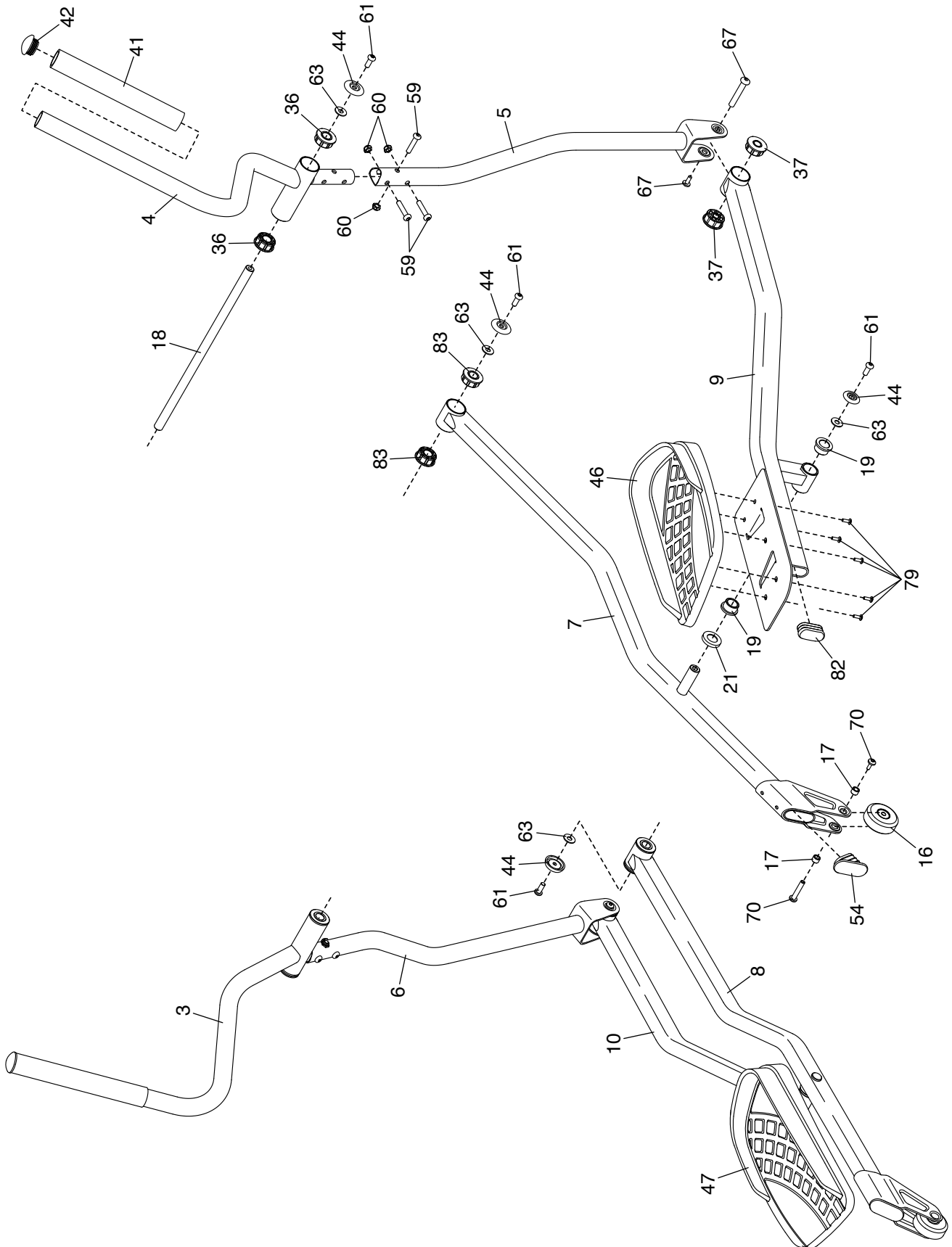

Get it fixed, at your home or ours!

Your Home

For repair—in **your home**—of **all** major brand appliances, lawn and garden equipment, or heating and cooling systems, **no matter who made it, no matter who sold it!**

For the replacement parts, accessories, and user's manuals that you need to do-it-yourself.

For Sears professional installation of home appliances and items like garage door openers and water heaters.

1-800-4-MY-HOME® (1-800-469-4663)

Call anytime, day or night (U.S.A. and Canada)

www.sears.com

www.sears.ca

Our Home

For repair of carry-in items like vacuums, lawn equipment, and electronics, call or go on-line for the location of your nearest **Sears Parts & Repair Center.**

1-800-488-1222 Call anytime, day or night (U.S.A. only)

www.sears.com

To purchase a protection agreement (U.S.A.) or maintenance agreement (Canada) on a product serviced by Sears:

1-800-827-6655 (U.S.A.)

1-800-361-6665 (Canada)

Para pedir servicio de reparación a domicilio, y para ordenar piezas:

1-888-SU-HOGAR® (1-888-784-6427)



® Registered Trademark / ™ Trademark / ™ Service Mark of Sears Brands, LLC
® Marca Registrada / ™ Marca de Fábrica / ™ Marca de Servicio de Sears Brands, LLC

90 DAY FULL WARRANTY

If this Sears Elliptical Exerciser fails due to a defect in material or workmanship within 90 days of the date of purchase, call 1-800-4-MY-HOME® (1-800-469-4663) to arrange for free repair (or replacement if repair proves impossible). The frame is warranted for 5 years.

This warranty does not apply when the Elliptical Exerciser is used commercially or for rental purposes.

This warranty gives you specific legal rights, and you may also have other rights which vary from state to state.

Sears, Roebuck and Co., Hoffman Estates, IL 60179