



UNDER COUNTER REFRIGERATOR

Use & Care Guide

For questions about features, operation/performance,
parts or service, call: **1-800-253-1301**

In Canada, call for assistance **1-800-807-6777**

or visit our website at...

www.whirlpool.com or www.whirlpool.ca

REFRIGERADOR PARA INSTALARSE DEBAJO DEL MOSTRADOR

Manual de uso y cuidado

Para consultas respecto a características, operación/desempeño, partes o servicio, llame al: **1-800-253-1301**

o visite nuestro sitio de internet en...

www.whirlpool.com

RÉFRIGÉRATEUR SOUS COMPTOIR

Guide d'utilisation et d'entretien

Au Canada, pour assistance, composez le **1-800-807-6777**

ou visitez notre site web à

www.whirlpool.ca

Table of Contents/Índice/Table des matières...2

TABLE OF CONTENTS

REFRIGERATOR SAFETY	3	REFRIGERATOR FEATURES	7
INSTALLATION INSTRUCTIONS	4	Refrigerator Shelves	7
Location Requirements	4	Lower Shelf	7
Electrical Requirements	4	REFRIGERATOR CARE	7
Unpack the Refrigerator	5	Cleaning	7
Reverse Door Swing (optional)	5	Changing the Light Bulb	8
Door Closing	6	Vacation and Moving Care	8
Base Grille	6	TROUBLESHOOTING	8
REFRIGERATOR USE	6	ASSISTANCE OR SERVICE	10
Normal Sounds	6	In the U.S.A.	10
Using the Control	7	In Canada	10
		Accessories	10
		WARRANTY	11

ÍNDICE

SEGURIDAD DEL REFRIGERADOR	12	CUIDADO DE SU REFRIGERADOR	17
INSTRUCCIONES DE INSTALACIÓN	13	Limpieza	17
Requisitos de ubicación	13	Cómo cambiar el foco	17
Requisitos eléctricos	13	Cuidado durante las vacaciones y mudanzas	17
Desempaque el refrigerador	14	SOLUCIÓN DE PROBLEMAS	18
Cambio del sentido de apertura de la puerta (opcional)	14	AYUDA O SERVICIO TÉCNICO	20
Cierre de la puerta	15	En los EE.UU.	20
Rejilla de la base	15	En Canadá	20
USO DE SU REFRIGERADOR	16	Accesorios	20
Sonidos normales	16	GARANTÍA	21
Uso del control	16		
CARACTERÍSTICAS DEL REFRIGERADOR	16		
Estantes del refrigerador	16		
Estante inferior	16		

TABLE DES MATIÈRES

SÉCURITÉ DU RÉFRIGÉRATEUR	23	ENTRETIEN DU RÉFRIGÉRATEUR	28
INSTRUCTIONS D'INSTALLATION	24	Nettoyage	28
Exigences d'emplacement	24	Changement de l'ampoule d'éclairage	28
Spécifications électriques	24	Précautions à prendre pour les vacances et avant un déménagement	29
Déballage du réfrigérateur	25	DÉPANNAGE	29
Inversion du sens de l'ouverture de la porte (facultatif)	25	ASSISTANCE OU SERVICE	30
Fermeture de la porte	26	Aux États-Unis	30
Grille de la base	27	Au Canada	31
UTILISATION DU RÉFRIGÉRATEUR	27	Accessoires	31
Sons normaux	27	GARANTIE	31
Utilisation de la commande	27		
CARACTÉRISTIQUES DU RÉFRIGÉRATEUR	27		
Tablettes du réfrigérateur	27		
Tablette inférieure	28		

REFRIGERATOR SAFETY

Your safety and the safety of others are very important.

We have provided many important safety messages in this manual and on your appliance. Always read and obey all safety messages.



This is the safety alert symbol.

This symbol alerts you to potential hazards that can kill or hurt you and others.

All safety messages will follow the safety alert symbol and either the word "DANGER" or "WARNING."

These words mean:

⚠ DANGER

You can be killed or seriously injured if you don't immediately follow instructions.

⚠ WARNING

You can be killed or seriously injured if you don't follow instructions.

All safety messages will tell you what the potential hazard is, tell you how to reduce the chance of injury, and tell you what can happen if the instructions are not followed.

IMPORTANT SAFETY INSTRUCTIONS

WARNING: To reduce the risk of fire, electric shock, or injury when using your refrigerator, follow these basic precautions:

- Plug into a grounded 3 prong outlet.
- Do not remove ground prong.
- Do not use an adapter.
- Do not use an extension cord.
- Disconnect power before servicing.
- Replace all parts and panels before operating.
- Remove doors from your old refrigerator.
- Use nonflammable cleaner.
- Keep flammable materials and vapors, such as gasoline, away from refrigerator.
- Use two or more people to move and install refrigerator.

SAVE THESE INSTRUCTIONS

State of California Proposition 65 Warnings:

WARNING: This product contains one or more chemicals known to the State of California to cause cancer.

WARNING: This product contains one or more chemicals known to the State of California to cause birth defects or other reproductive harm.

Proper Disposal of Your Old Refrigerator

⚠ WARNING

Suffocation Hazard

Remove doors from your old refrigerator.

Failure to do so can result in death or brain damage.

IMPORTANT: Child entrapment and suffocation are not problems of the past. Junked or abandoned refrigerators are still dangerous – even if they will sit for "just a few days." If you are getting rid of your old refrigerator, please follow these instructions to help prevent accidents.

Before You Throw Away Your Old Refrigerator or Freezer:

- Take off the door.

- Leave the shelves in place so that children may not easily climb inside.

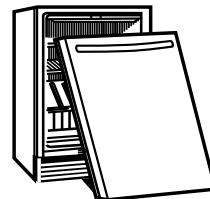

Important information to know about disposal of refrigerants:

Dispose of refrigerator in accordance with Federal and Local regulations. Refrigerants must be evacuated by a licensed, EPA certified refrigerant technician in accordance with established procedures.

INSTALLATION INSTRUCTIONS

Location Requirements

⚠ WARNING



Explosion Hazard

Keep flammable materials and vapors, such as gasoline, away from refrigerator.

Failure to do so can result in death, explosion, or fire.

To ensure proper ventilation for your refrigerator, allow for a 1/4" (6.35 mm) space on each side and at the top. When installing your refrigerator next to a fixed wall, leave 2 1/2" (6.35 cm) minimum clearance on the hinge side to allow for the door to swing open.

NOTE: It is recommended that you do not install the refrigerator near an oven, radiator, or other heat source. Do not install in a location where the temperature will fall below 55°F (13°C). For best performance, do not install the refrigerator behind a cabinet door or block the base grille.

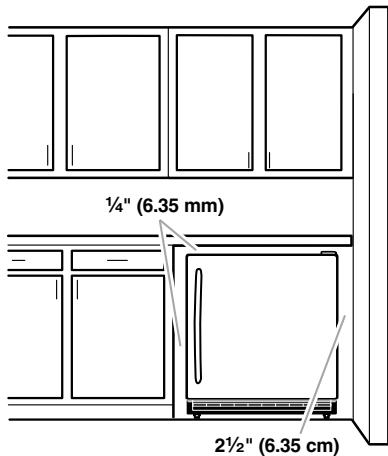

Opening Dimensions

- Height dimensions are shown with the leveling legs extended to the minimum height.

NOTE: When leveling legs are fully extended, add 5/8" (1.6 cm) to the height dimensions. See "Product Dimensions."

- If the floor of the opening is not level with the kitchen floor, shim the opening to make it level with the kitchen floor.

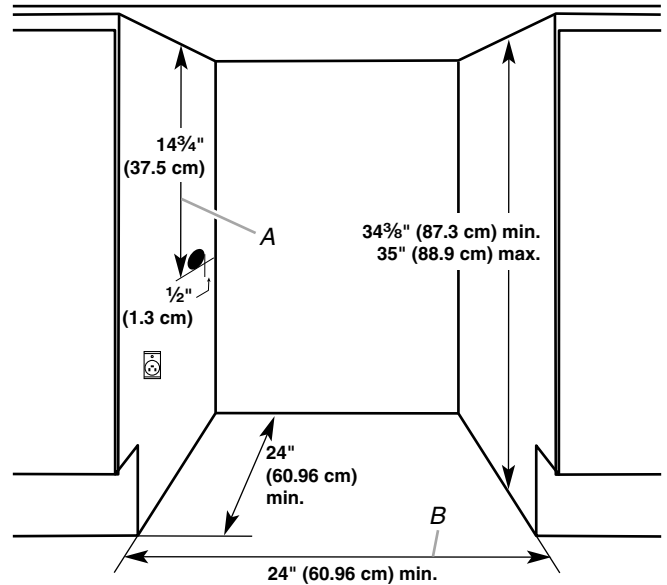

Critical Dimensions:

A. 14 3/4" (37.5 cm) utility opening

B. 24" (60.96 cm) minimum opening width

Electrical Requirements

⚠ WARNING



Electrical Shock Hazard

Plug into a grounded 3 prong outlet.

Do not remove ground prong.

Do not use an adapter.

Do not use an extension cord.

Failure to follow these instructions can result in death, fire, or electrical shock.

Before you move your refrigerator into its final location, it is important to make sure you have the proper electrical connection.

Recommended grounding method

A 115 Volt, 60 Hz., AC only, 15- or 20-amp fused, grounded electrical supply is required. It is recommended that a separate circuit serving only your refrigerator be provided. Use an outlet that cannot be turned off by a switch. Do not use an extension cord.

NOTE: Before performing any type of installation, cleaning, or removing a light bulb, unplug refrigerator or disconnect power.

Unpack the Refrigerator

⚠️ WARNING

Excessive Weight Hazard

Use two or more people to move and install refrigerator.

Failure to do so can result in back or other injury.

Remove the Packaging

- Remove tape and glue residue from surfaces before turning on the refrigerator. Rub a small amount of liquid dish soap over the adhesive with your fingers. Wipe with warm water and dry.
- Do not use sharp instruments, rubbing alcohol, flammable fluids, or abrasive cleaners to remove tape or glue. These products can damage the surface of your refrigerator. For more information, see “Refrigerator Safety.”
- Dispose of/recycle all packaging materials.

When Moving Your Refrigerator:

Your refrigerator is heavy. When moving the refrigerator for cleaning or service, be sure to cover the floor with cardboard or hardboard to avoid floor damage. Always pull the refrigerator straight out when moving it. Do not wiggle or “walk” the refrigerator when trying to move it, as floor damage could occur.

Clean Before Using

After you remove all of the package materials, clean the inside of your refrigerator before using it. See the cleaning instructions in “Refrigerator Care.”

Important information to know about glass shelves and covers:

Do not clean glass shelves or covers with warm water when they are cold. Shelves and covers may break if exposed to sudden temperature changes or impact, such as bumping. Tempered glass is designed to shatter into many small, pebble-size pieces. This is normal. Glass shelves and covers are heavy. Use both hands when removing them to avoid dropping.

Reverse Door Swing (optional)

Tools Needed: Phillips screwdriver

1. Unplug refrigerator or disconnect power.
2. Remove the screws from each side of the top of the refrigerator cabinet and set aside.
NOTE: There are seven screws total. Do not discard.
3. Remove the hinge cover and washer and set aside.

Top View

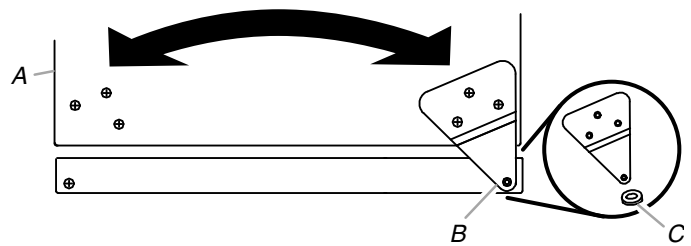

A. Top of refrigerator cabinet
B. Hinge cover
C. Washer

4. Lift the door straight up and off of the bottom hinge.
5. Remove the screws fastening the bottom hinge and cover to the bottom of the refrigerator cabinet. There are five screws total.
6. Move the bottom hinge and cover each to the opposite side of the bottom of the refrigerator cabinet. Completely tighten the five screws.

Front View

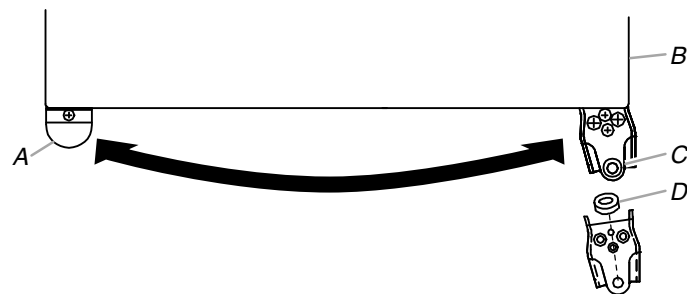

A. Cover
B. Bottom of refrigerator cabinet
C. Bottom hinge
D. Washer

7. Remove the two screws fastening the door stop spacer and the door stop to the bottom of the refrigerator door.
8. Move the door stop spacer and the door stop to the opposite side and fasten with the two screws. Completely tighten the screws.

Bottom View

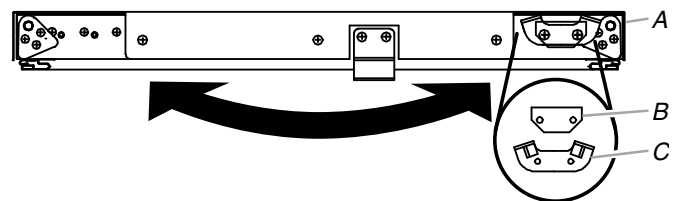

A. Bottom of refrigerator door
B. Door stop spacer
C. Door stop

9. Place the washer onto the bottom hinge, then install the refrigerator door onto the washer and hinge pin.



A. Bottom hinge washer
B. Bottom hinge

- Align the top hinge washer with the hinge hole in the top of the door. Then, insert the top hinge pin through the washer and into the hinge hole.
- Fasten the top hinge cover with three screws and move the remaining four screws to the opposite side. Completely tighten the seven screws.

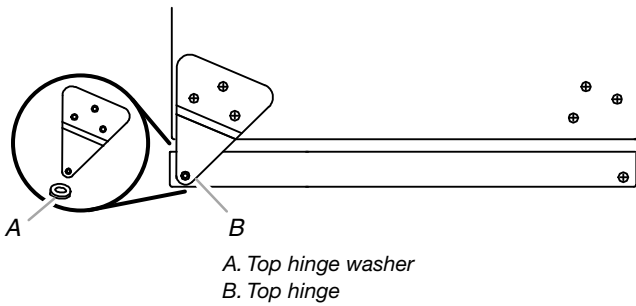

Door Closing

Door Closing

Your refrigerator has four leveling legs. If your refrigerator seems unsteady or you want the door to close more easily, adjust the refrigerator's tilt using the instructions below.

⚠ WARNING



Electrical Shock Hazard

- Plug into a grounded 3 prong outlet.
- Do not remove ground prong.
- Do not use an adapter.
- Do not use an extension cord.
- Failure to follow these instructions can result in death, fire, or electrical shock.

- Plug into a grounded 3 prong outlet.

⚠ WARNING

Excessive Weight Hazard

- Use two or more people to move and install refrigerator.
- Failure to do so can result in back or other injury.

- Move the refrigerator into its final location.
 - Turn the leveling legs to the right to lower the refrigerator or turn the leveling legs to the left to raise it. It may take several turns of the leveling legs to adjust the tilt of the refrigerator.
- NOTE:** Having someone push against the top of the refrigerator takes some weight off the leveling legs. This makes it easier to adjust the leveling legs.

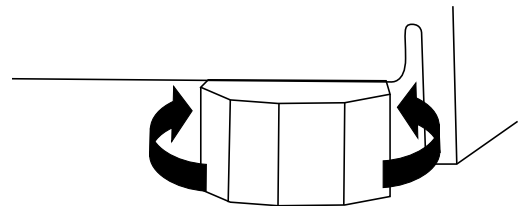

- Open the door again to make sure that it closes as easily as you like. If not, tilt the refrigerator slightly more to the rear by turning both front leveling screws to the left. It may take several more turns, and you should turn both leveling legs the same amount.

Base Grille

Tools Needed: Phillips screwdriver

Remove the Base Grille

- Open the refrigerator door.
- Using a Phillips screwdriver, remove the two screws. Push both tabs in toward the center to release the base grille from the refrigerator.

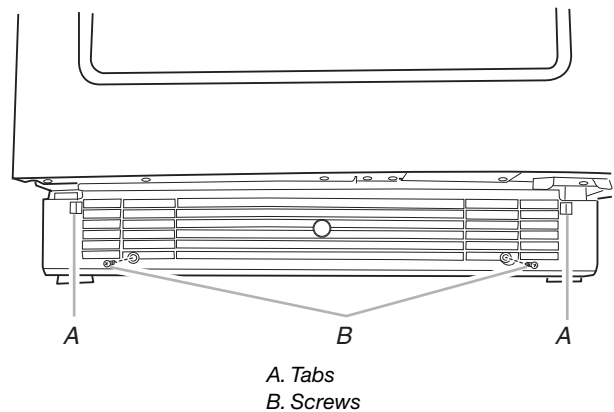

- Remove the base grille.

Replace the Base Grille

- Open the refrigerator door.
- Position the base grille so that both tabs align and the base grille snaps into place. Replace the two screws. Tighten the screws.

REFRIGERATOR USE

Normal Sounds

Your new refrigerator may make sounds that your old one didn't make. Because the sounds are new to you, you might be concerned about them. Most of the new sounds are normal. Hard surfaces, such as the flooring and surrounding structures, can make the sounds seem louder. The following describes the kinds of sounds and what may be making them.

- Your refrigerator is designed to run more efficiently to keep your food items at the desired temperatures and to minimize energy usage. The high efficiency compressor and fans may cause your refrigerator to run longer than your old one. You may also hear a pulsating or high-pitched sound from the compressor or fans adjusting to optimize performance.
- Rattling noises may come from the flow of refrigerant or items stored inside the refrigerator.

- As each cycle ends, you may hear a gurgling sound due to the refrigerant flowing in your refrigerator.
- You may hear water running into the drain pan when the refrigerator is defrosting.
- You may hear clicking sounds when the refrigerator starts or stops running.

Using the Control

For your convenience, your refrigerator control is preset at the factory. When you first install your refrigerator, make sure that the control is still preset to the mid-setting as shown.

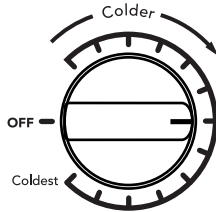

Adjusting Controls

The mid-setting indicated in the previous section should be correct for normal usage. The control is set correctly when beverages are as cold as you like.

If you need to adjust the temperature, wait at least 24 hours between adjustments and then recheck the temperature.

To make the refrigerator colder, adjust the control to the next higher setting. To make the refrigerator less cold, adjust the control to the next lower setting.

REFRIGERATOR FEATURES

Important information to know about glass shelves and covers:

Do not clean glass shelves or covers with warm water when they are cold. Shelves and covers may break if exposed to sudden temperature changes or impact, such as bumping. Tempered glass is designed to shatter into many small, pebble-size pieces. This is normal. Glass shelves and covers are heavy. Use both hands when removing them to avoid dropping.

Refrigerator Shelves

Your model may have glass or wire shelves. Store similar foods together. This reduces the time the refrigerator door is open and saves energy.

To Remove and Replace Shelves:

1. Remove the shelf by lifting up the front and pulling it out of the shelf slots.
2. Replace the shelf by inserting it into the shelf slots and pushing it toward the back of the compartment.

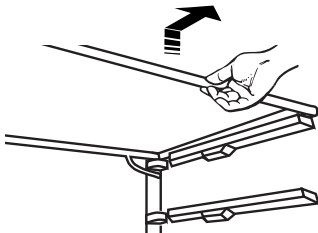

Lower Shelf

To Remove and Replace Lower Shelf:

1. Remove the shelf by lifting it up and pulling it forward.
2. Replace the shelf by lowering it on the guides.

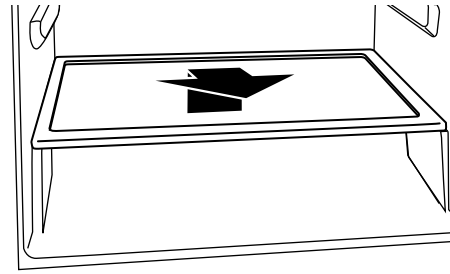

REFRIGERATOR CARE

Cleaning

⚠ WARNING



Explosion Hazard

Use nonflammable cleaner.

Failure to do so can result in death, explosion, or fire.

Clean the refrigerator about once a month to avoid buildup of odors. Wipe up spills immediately.

To clean your refrigerator:

1. Unplug refrigerator or disconnect power.
2. Remove all removable parts from inside, such as shelves, etc.
3. Hand wash, rinse, and dry removable parts and interior surfaces thoroughly. Use a clean sponge or soft cloth and a mild detergent in warm water.
 - Do not use abrasive or harsh cleaners such as window sprays, scouring cleansers, flammable fluids, cleaning waxes, concentrated detergents, bleaches or cleansers containing petroleum products on plastic parts, interior and door liners or gaskets. Do not use paper towels, scouring pads, or other harsh cleaning tools. These can scratch or damage materials.
 - To help remove odors, you can wash interior walls with a mixture of warm water and baking soda (2 tbs to 1 qt [26 g to 0.95 L] of water).

- Wash stainless steel and painted metal exteriors with a clean sponge or soft cloth and a mild detergent in warm water. Do not use abrasive or harsh cleaners, or cleaners containing chlorine. These can scratch or damage materials. Dry thoroughly with a soft cloth.

NOTE: To keep your stainless steel refrigerator looking like new and to remove minor scuffs or marks, it is suggested that you use the manufacturer's approved Stainless Steel Cleaner and Polish. To order the cleaner, see "Accessories."

IMPORTANT: This cleaner is for stainless steel parts only!

Do not allow the Stainless Steel Cleaner and Polish to come into contact with any plastic parts such as the trim pieces, dispenser covers or door gaskets. If unintentional contact does occur, clean plastic part with a sponge and mild detergent in warm water. Dry thoroughly with a soft cloth.

- Replace the removable parts.
- Clean the condenser coils regularly. They are located behind the base grille. Coils may need to be cleaned as often as every other month. This may help save energy.
 - Remove the base grille. See "Base Grille."
 - Use a vacuum cleaner with an extended attachment to clean the condenser coils when they are dusty or dirty.
 - Replace the base grille.
- Plug in refrigerator or reconnect power.

Changing the Light Bulb

NOTE: Not all appliance bulbs will fit your refrigerator. Be sure to replace the bulb with one of the same size, shape, and wattage.

To change the light bulb:

- Unplug refrigerator or disconnect power.
- Using a Phillips screwdriver, remove the screw located at the back of the light shield. Pull the light shield back to remove the tabs from the appliance. Remove the light shield.

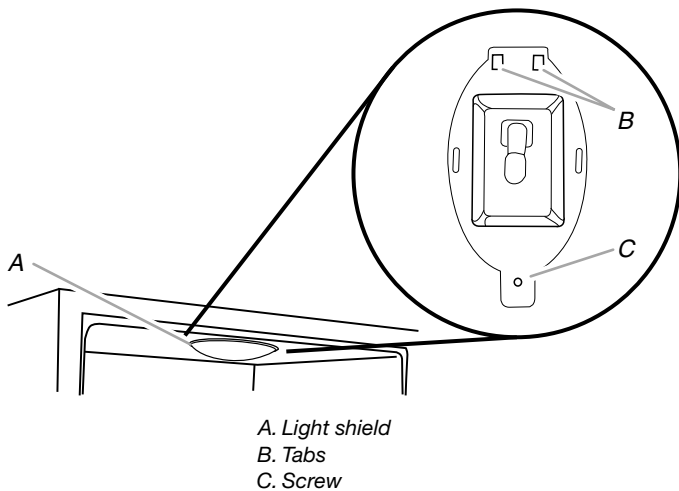

- Replace the bulb.
- Reinstall the light shield by inserting the tabs. Align the holes and insert the screw. Tighten the screw.
- Plug in refrigerator or reconnect power.

Vacation and Moving Care

Vacations

If you choose to leave the refrigerator on while you're away, use up any perishables and freeze other items.

If you choose to turn the refrigerator off before you leave, follow these steps.

- Remove all food from the refrigerator.
- Unplug the refrigerator.
- Clean the refrigerator. See "Cleaning."
- Tape a rubber or wood block to the top of the door to prop it open far enough for air to get in. This stops odor and mold from building up.

Moving

When you are moving your refrigerator to a new home, follow these steps to prepare it for the move.

- Remove all food from the refrigerator.
- Unplug the refrigerator.
- Clean, wipe, and dry it thoroughly.
- Take out all removable parts, wrap them well, and tape them together so they don't shift and rattle during the move.
- Tape the doors shut and tape the power cord to the back of the refrigerator.

When you get to your new home, put everything back and refer to the "Installation Instructions" section for preparation instructions.

TROUBLESHOOTING

Try the solutions suggested here first in order to avoid the cost of an unnecessary service call.

Your refrigerator will not operate

⚠ WARNING



Electrical Shock Hazard

Plug into a grounded 3 prong outlet.

Do not remove ground prong.

Do not use an adapter.

Do not use an extension cord.

Failure to follow these instructions can result in death, fire, or electrical shock.

- Is the power supply cord unplugged?** Plug into a grounded 3 prong outlet.
- Has a household fuse blown, or has a circuit breaker tripped?** Replace the fuse or reset the circuit.
- Is the Refrigerator Control turned to the OFF position?** See "Using the Control."

The motor seems to run too much

- Is the temperature outside hotter than normal?** Expect the motor to run longer under warm conditions. At normal outdoor temperatures, expect your motor to run about 40% to 80% of the time. Under warmer conditions, expect it to run even more of the time.

- **Has a large amount of food just been added to the refrigerator?** Adding a large amount of food warms the refrigerator. It is normal for the motor to run longer in order to cool the refrigerator back down.
- **Is the door opened often?** Expect the motor to run longer when this occurs. In order to conserve energy, try to get everything you need out of the refrigerator at once, keep food organized so it is easy to find, and close the door as soon as the food is removed.
- **Is the control set correctly for the surrounding conditions?** See “Using the Control.”
- **Is the door closed completely?** Push the door firmly shut. If it will not shut all the way, see “The door will not close completely” later in this section.
- **Are the condenser coils dirty?** This obstructs air transfer and makes the motor work harder. Clean the condenser coils. See “Cleaning.”

Temperature is too warm

- **Is the door opened often?** Be aware that the refrigerator will warm when this occurs. In order to keep the refrigerator cool, try to get everything you need out of the refrigerator at once, keep food organized so it is easy to find, and close the door as soon as the food is removed.
- **Has a large amount of food just been added to the refrigerator?** Adding a large amount of food warms the refrigerator. It can take several hours for the refrigerator to return to the normal temperature.
- **Is the control set correctly for the surrounding conditions?** See “Using the Control.”
- **Is the base grille blocked?** For best performance, do not install the refrigerator behind a cabinet door or block the base grille.

There is interior moisture buildup

- **Is the door opened often?** To avoid humidity buildup, try to get everything you need out of the refrigerator at once, keep food organized so it is easy to find, and close the door as soon as the food is removed. When the door is opened, humidity from the room air enters the refrigerator. The more often the door is opened, the faster humidity builds up, especially when the room itself is very humid.
- **Is it humid?** It is normal for moisture to build up inside the refrigerator when the air is humid.
- **Is the food packaged correctly?** Check that all food is securely wrapped. Wipe off damp food containers before placing in the refrigerator.
- **Is the control set correctly for the surrounding conditions?** See “Using the Control.”

The door is difficult to open

WARNING



Explosion Hazard

Use nonflammable cleaner.

Failure to do so can result in death, explosion, or fire.

- **Is the gasket dirty or sticky?** Clean the gasket and the surface that it touches. Rub a thin coat of paraffin wax on the gasket following cleaning.

The door will not close completely

- **Are food packages blocking the door open?** Rearrange containers so that they fit more tightly and take up less space.
- **Are the shelves out of position?** Put the shelves back into their correct positions. See “Refrigerator Use” for more information.

WARNING



Explosion Hazard

Use nonflammable cleaner.

Failure to do so can result in death, explosion, or fire.

- **Is the gasket sticking?** Clean the gasket and the surface that it touches. Rub a thin coat of paraffin wax on the gasket following cleaning.

ASSISTANCE OR SERVICE

Before calling for assistance or service, please check "Troubleshooting." It may save you the cost of a service call. If you still need help, follow the instructions below.

When calling, please know the purchase date and the complete model and serial number of your appliance. This information will help us to better respond to your request.

If You Need Replacement Parts

If you need to order replacement parts, we recommend that you only use factory specified replacement parts. Factory specified replacement parts will fit right and work right because they are made with the same precision used to build every new Whirlpool® appliance.

To locate factory specified replacement parts in your area, call us or your nearest designated service center.

In the U.S.A.

Call the Whirlpool Customer eXperience Center toll free: **1-800-253-1301**.

Our Consultants Provide Assistance With:

- Features and specifications on our full line of appliances.
- Installation information.
- Use and maintenance procedures.
- Accessory and repair parts sales.
- Specialized customer assistance (Spanish speaking, hearing impaired, limited vision, etc.).
- Referrals to local dealers, repair parts distributors, and service companies. Whirlpool designated service technicians are trained to fulfill the product warranty and provide after-warranty service, anywhere in the United States.

To locate the Whirlpool designated service company in your area, you can also look in your telephone directory Yellow Pages.

For Further Assistance

If you need further assistance, you can write to Whirlpool with any questions or concerns at:

Whirlpool Brand Home Appliances
Customer eXperience Center
553 Benson Road
Benton Harbor, MI 49022-2692

Please include a daytime phone number in your correspondence.

In Canada

Call the Whirlpool Canada Customer eXperience Centre toll free: **1-800-807-6777**, or visit our website at **www.whirlpool.ca**.

Our Consultants Provide Assistance With:

- Features and specifications on our full line of appliances.
- Use and maintenance procedures.
- Accessory and repair parts sales.
- Scheduling of Service. Whirlpool designated service technicians are trained to fulfill the product warranty and provide after-warranty service, anywhere in Canada.

For Further Assistance

If you need further assistance, you can write to Whirlpool Canada with any questions or concerns at:

Whirlpool Brand Home Appliances
Customer eXperience Centre
200 - 6750 Century Ave.
Mississauga, Ontario L5N 0B7

Please include a daytime phone number in your correspondence.

Accessories

The following accessory is available for your wine cooler. To order accessory, contact us and ask for the part number.

In the U.S.A., visit our webpage **www.whirlpool.com/accessories** or call **1-800-253-1301**.

In Canada, visit our webpage **www.whirlpoolparts.ca** or call **1-800-807-6777**.

Stainless Steel Cleaner & Polish

Order Part #4396095

WHIRLPOOL® REFRIGERATION LIMITED WARRANTY

ATTACH YOUR RECEIPT HERE. PROOF OF PURCHASE IS REQUIRED TO OBTAIN WARRANTY SERVICE.

Please have the following information available when you call the Customer eXperience Center:

- Name, address and telephone number
- Model number and serial number
- A clear, detailed description of the problem
- Proof of purchase including dealer or retailer name and address

IF YOU NEED SERVICE:

1. Before contacting us to arrange service, please determine whether your product requires repair. Some questions can be addressed without service. Please take a few minutes to review the Troubleshooting or Problem Solver section of the Use and Care Guide, scan the QR code on the right to access additional resources, or visit www.whirlpool.com/product_help.
2. All warranty service is provided exclusively by our authorized Whirlpool Service Providers. In the U.S. and Canada, direct all requests for warranty service to:



www.whirlpool.com/product_help

Whirlpool Customer eXperience Center

In the U.S.A., call 1-800-253-1301. In Canada, call 1-800-807-6777.

If outside the 50 United States or Canada, contact your authorized Whirlpool dealer to determine whether another warranty applies.

FIVE YEAR LIMITED WARRANTY

WHAT IS COVERED

LIMITED WARRANTY

For one year from the date of purchase, when this major appliance is installed, operated and maintained according to instructions attached to or furnished with the product, Whirlpool Corporation or Whirlpool Canada LP (hereafter "Whirlpool") will pay for Factory Specified Replacement Parts and repair labor to correct defects in materials or workmanship that existed when this major appliance was purchased, or at its sole discretion replace the product. In the event of product replacement, your appliance will be warranted for the remaining term of the original unit's warranty period.

SECOND THROUGH FIFTH YEAR LIMITED WARRANTY ON CAVITY LINER AND SEALED REFRIGERATION SYSTEM

In the second through fifth years from the date of purchase, when this major appliance is installed, operated and maintained according to the instructions attached to or furnished with the product, Whirlpool brand will pay for factory specified replacement parts and repair labor for the following components to correct non-cosmetic defects in materials and workmanship in this part that prevent function of the refrigerator and that existed when this major appliance was purchased:

- Refrigerator/freezer cavity liner if the part cracks due to defective materials or workmanship.
- Sealed Refrigeration system (includes compressor, evaporator, condenser, dryer and connecting tubing).

YOUR SOLE AND EXCLUSIVE REMEDY UNDER THIS LIMITED WARRANTY SHALL BE PRODUCT REPAIR AS PROVIDED HEREIN. Service must be provided by a Whirlpool designated service company. This limited warranty is valid only in the United States or Canada and applies only when the major appliance is used in the country in which it was purchased. This limited warranty is effective from the date of original consumer purchase. Proof of original purchase date is required to obtain service under this limited warranty.

WHAT IS NOT COVERED

1. Commercial, non-residential, multiple-family use, or use inconsistent with published user, operator or installation instructions.
2. In-home instruction on how to use your product.
3. Service to correct improper product maintenance or installation, installation not in accordance with electrical or plumbing codes or correction of household electrical or plumbing (i.e. house wiring, fuses or water inlet hoses).
4. Consumable parts (i.e. light bulbs, batteries, air or water filters, preservation solutions, etc.).
5. Defects or damage caused by the use of non-genuine Whirlpool parts or accessories.
6. Conversion of products from natural gas or L.P. gas.
7. Damage from accident, misuse, abuse, fire, floods, acts of God or use with products not approved by Whirlpool.
8. Repairs to parts or systems to correct product damage or defects caused by unauthorized service, alteration or modification of the appliance.
9. Cosmetic damage including scratches, dents, chips, and other damage to the appliance finishes unless such damage results from defects in materials and workmanship and is reported to Whirlpool within 30 days.
10. Discoloration, rust or oxidation of surfaces resulting from caustic or corrosive environments including but not limited to high salt concentrations, high moisture or humidity or exposure to chemicals.
11. Food or medicine loss due to product failure.
12. Pick-up or delivery. This product is intended for in-home repair.
13. Travel or transportation expenses for service in remote locations where an authorized Whirlpool servicer is not available.
14. Removal or reinstallation of inaccessible appliances or built-in fixtures (i.e. trim, decorative panels, flooring, cabinetry, islands, countertops, drywall, etc.) that interfere with servicing, removal or replacement of the product.
15. Service or parts for appliances with original model/serial numbers removed, altered or not easily determined.

The cost of repair or replacement under these excluded circumstances shall be borne by the customer.

DISCLAIMER OF IMPLIED WARRANTIES

IMPLIED WARRANTIES, INCLUDING ANY IMPLIED WARRANTY OF MERCHANTABILITY OR IMPLIED WARRANTY OF FITNESS FOR A PARTICULAR PURPOSE, ARE LIMITED TO ONE YEAR OR THE SHORTEST PERIOD ALLOWED BY LAW. Some states and provinces do not allow limitations on the duration of implied warranties of merchantability or fitness, so this limitation may not apply to you. This warranty gives you specific legal rights, and you also may have other rights that vary from state to state or province to province.

DISCLAIMER OF REPRESENTATIONS OUTSIDE OF WARRANTY

Whirlpool makes no representations about the quality, durability, or need for service or repair of this major appliance other than the representations contained in this warranty. If you want a longer or more comprehensive warranty than the limited warranty that comes with this major appliance, you should ask Whirlpool or your retailer about buying an extended warranty.

LIMITATION OF REMEDIES; EXCLUSION OF INCIDENTAL AND CONSEQUENTIAL DAMAGES

YOUR SOLE AND EXCLUSIVE REMEDY UNDER THIS LIMITED WARRANTY SHALL BE PRODUCT REPAIR AS PROVIDED HEREIN. WHIRLPOOL SHALL NOT BE LIABLE FOR INCIDENTAL OR CONSEQUENTIAL DAMAGES. Some states and provinces do not allow the exclusion or limitation of incidental or consequential damages, so these limitations and exclusions may not apply to you. This warranty gives you specific legal rights, and you also may have other rights that vary from state to state or province to province.

CE QUI EST COUVERT

GARANTIE LIMITÉE

Pendant un an à compter de la date d'achat, lorsque ce gros appareil ménager est installé, utilisé et entretenu conformément aux instructions jointes au produit ou fournies avec, Whirlpool Corporation ou Whirlpool Canada LP (ci-après désignées "Whirlpool") décidera à sa seule discrétion de remplacer le produit ou de payer pour les pièces spécifiées par l'usine et la main-d'œuvre nécessaires pour corriger les vices de matériaux ou de fabrication qui existaient déjà lorsque ce gros appareil ménager a été acheté. S'il est remplacé, votre appareil restera sous garantie pour la durée restant à courir de la période de garantie sur le produit d'origine.

GARANTIE LIMITÉE DE LA DEUXIÈME À LA CINQUIÈME ANNÉE INCLUSIVEMENT SUR LA DOUBLURE DE LA CAVITÉ ET SUR LE SYSTÈME DE RÉFRIGÉRATION SCELLÉ

De la deuxième à la cinquième année inclusivement à compter de la date d'achat initiale, lorsque ce gros appareil ménager est installé, utilisé et entretenu conformément aux instructions jointes au produit ou fournies avec, la marque Whirlpool paiera pour les pièces de rechange spécifiées par l'usine et la main-d'œuvre concernant les composants suivants pour corriger les défauts non esthétiques de matériau ou de fabrication de ladite pièce qui empêchent le réfrigérateur de fonctionner et qui étaient déjà présents lorsque ce gros appareil ménager a été acheté :

- Doublure de la cavité du réfrigérateur/congélateur si la pièce se fissure en raison d'un vice de matériau ou de fabrication.
- Système de réfrigération scellé (y compris le compresseur, l'évaporateur, le condenseur, le séchoir et les conduits de connexion).

LE SEUL ET EXCLUSIF RECOURS DU CLIENT DANS LE CADRE DE LA PRÉSENTE GARANTIE LIMITÉE CONSISTE EN LA RÉPARATION PRÉVUE PAR LA PRÉSENTE. Le service doit être fourni par une compagnie de service désignée par Whirlpool. Cette garantie limitée est valide uniquement aux États-Unis ou au Canada et s'applique exclusivement lorsque le gros appareil ménager est utilisé dans le pays où il a été acheté. La présente garantie limitée est valable à compter de la date d'achat initial par le consommateur. Une preuve de la date d'achat initial est exigée pour obtenir un dépannage dans le cadre de la présente garantie limitée.

CE QUI N'EST PAS COUVERT

1. Usage commercial, non résidentiel ou par plusieurs familles, ou non-respect des instructions de l'utilisateur, de l'opérateur ou des instructions d'installation.
2. Visite d'instruction à domicile pour montrer à l'utilisateur comment utiliser l'appareil.
3. Visites de service pour rectifier une installation ou un entretien fautifs du produit, une installation non conforme aux codes d'électricité ou de plomberie, ou la rectification de l'installation électrique ou de la plomberie du domicile (ex : câblage électrique, fusibles ou tuyaux d'arrivée d'eau du domicile).
4. Pièces consommables (ex : ampoules, batteries, filtres à air ou à eau, solutions de conservation, etc.).
5. Défauts ou dommage résultant de l'utilisation de pièces ou accessoires Whirlpool non authentiques.
6. Conversion de votre produit du gaz naturel ou du gaz de pétrole liquéfié.
7. Dommages causés par : accident, usage impropre ou abusif, incendie, inondations, catastrophe naturelle ou utilisation de produits non approuvés par Whirlpool.
8. Réparations aux pièces ou systèmes dans le but de rectifier un dommage ou des défauts résultant d'une réparation ou modification non autorisée faite à l'appareil.
9. Défauts d'apparence, notamment les éraflures, traces de choc, fissures ou tout autre dommage subi par le fini de l'appareil ménager, à moins que ces dommages ne résultent de vices de matériaux ou de fabrication et ne soient signalés à Whirlpool dans les 30 jours suivant la date d'achat.
10. Décoloration, rouille ou oxydation des surfaces résultant d'environnements caustiques ou corrosifs incluant des concentrations élevées de sel, un haut degré d'humidité ou une exposition à des produits chimiques (exemples non exhaustifs).
11. Perte d'aliments ou de médicaments due à une défaillance du produit.
12. Enlèvement ou livraison. Ce produit est conçu pour être réparé à domicile.
13. Frais de déplacement ou de transport pour le dépannage/la réparation dans une région éloignée où un fournisseur de services d'entretien ou de réparation Whirlpool autorisée n'est pas disponible.
14. Retrait ou réinstallation d'appareils inaccessibles ou de dispositifs préinstallés (ex : garnitures, panneaux décoratifs, plancher, meubles, îlots de cuisine, plans de travail, panneaux de gypse, etc.) qui entravent le dépannage, le retrait ou le remplacement du produit.
15. Service et pièces pour les appareils dont les numéros de série et de modèle originaux ont été enlevés, modifiés ou ne peuvent pas être facilement identifiés.

Le coût d'une réparation ou d'un remplacement dans le cadre de ces circonstances exclues est à la charge du client.

CLAUSE D'EXONÉRATION DE RESPONSABILITÉ AU TITRE DES GARANTIES IMPLICITES

LES GARANTIES IMPLICITES, Y COMPRIS LES GARANTIES APPLICABLES DE QUALITÉ MARCHANDE OU D'APTITUDE À UN USAGE PARTICULIER, SONT LIMITÉES À UN AN OU À LA PLUS COURTE PÉRIODE AUTORISÉE PAR LA LOI. Certains États et provinces ne permettent pas de limitation sur la durée des garanties implicites de qualité marchande ou d'aptitude à un usage particulier, de sorte que la limitation ci-dessus peut ne pas être applicable dans votre cas. Cette garantie vous confère des droits juridiques spécifiques et vous pouvez également jouir d'autres droits qui peuvent varier d'une juridiction à l'autre.

EXONÉRATION DE RESPONSABILITÉ DANS LES DOMAINES NON COUVERTS PAR LA GARANTIE

Whirlpool décline toute responsabilité au titre de la qualité ou de la durabilité de l'appareil, ou en cas de dépannage ou de réparation nécessaire sur ce gros appareil ménager autre que les responsabilités énoncées dans la présente garantie. Si vous souhaitez une garantie plus étendue ou plus complète que la garantie limitée fournie avec ce gros appareil ménager, adressez-vous à Whirlpool ou à votre détaillant pour obtenir les modalités d'achat d'une garantie étendue.

LIMITATION DES RECOURS; EXCLUSION DES DOMMAGES FORTUITS OU INDIRECTS

LE SEUL ET EXCLUSIF RECOURS DU CLIENT DANS LE CADRE DE LA PRÉSENTE GARANTIE LIMITÉE CONSISTE EN LA RÉPARATION PRÉVUE PAR LA PRÉSENTE. WHIRLPOOL N'ASSUME AUCUNE RESPONSABILITÉ POUR LES DOMMAGES FORTUITS OU INDIRECTS. Certains États et certaines provinces ne permettent pas l'exclusion ou la limitation des dommages fortuits ou indirects de sorte que ces limitations et exclusions peuvent ne pas être applicables dans votre cas. Cette garantie vous confère des droits juridiques spécifiques et vous pouvez également jouir d'autres droits qui peuvent varier d'une juridiction à l'autre.