

Owner's Manual

CRAFTSMAN®

ROTARY LAWN MOWER

725 Series Briggs & Stratton Engine

Power-Propelled

22" Multi-Cut

Model No.

944.364741

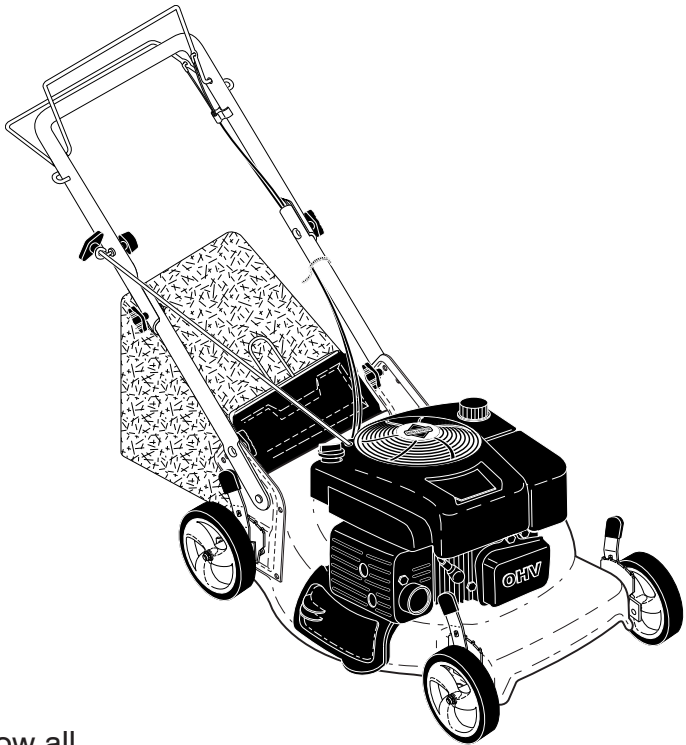

CAUTION:

Read and follow all
Safety Rules and Instructions
before operating this equipment

Sears Canada, Inc., Toronto, Ontario M5B 2B8

TABLE OF CONTENTS

Safety Rules	2-3	Maintenance.....	13-16
Warranty	4-5	Service and Adjustments	17-18
Product Specifications	5	Storage.....	18-19
Assembly/Pre-Operation.....	6-7	Troubleshooting	20-21
Operation	8-12	Repair Parts.....	22-31
Maintenance Schedule	13	Sears Service	Back Cover

SAFETY RULES

IMPORTANT: This cutting machine is capable of amputating hands and feet and throwing objects. Failure to observe the following safety instructions could result in serious injury or death.

⚠️ Look for this symbol to point out important safety precautions. It means **CAUTION!!! BECOME ALERT!!! YOUR SAFETY IS INVOLVED.**

⚠️ **WARNING:** In order to prevent accidental starting when setting up, transporting, adjusting or making repairs, always disconnect spark plug wire and place wire where it cannot come in contact with plug.

⚠️ **CAUTION:** Muffler and other engine parts become extremely hot during operation and remain hot after engine has stopped. To avoid severe burns on contact, stay away from these areas.

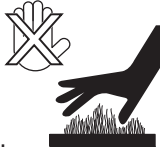

I. CHILDREN



WARNING: CHILDREN CAN BE SERIOUSLY INJURED OR KILLED BY THIS EQUIPMENT. Carefully read and follow all of the safety instructions below.

The American Academy of Pediatrics recommends that children be a minimum of 12 year of age before operating a pedestrian controlled lawn mower and a minimum of 16 years of age before operating a riding lawn mower.

Tragic accidents can occur if the operator is not alert to the presence of children. Children are often attracted to the machine and the mowing activity. Never assume that children will remain where you last saw them.

- Keep children out of the mowing area and under the watchful care of a responsible adult other than the operator.
- Be alert and turn machine off if children enter the area.
- Before and while walking backwards, look behind and down for small children.
- Never allow children to operate the machine.

II. GENERAL OPERATION

- Read, understand, and follow all instructions on the machine and in the manual(s) before starting. Be thoroughly familiar with the controls and the proper use of the machine before starting.
- Do not put hands or feet near or under rotating parts. Keep clear of the discharge opening at all times.
- Only allow responsible individuals, who are familiar with the instructions, to operate the machine.
- Clear the area of objects such as rocks, toys, wire, bones, sticks, etc., which could be picked up and thrown by blade. Stay behind the handle when the engine (motor) is running.
- Be sure the area is clear of other people before mowing. Stop machine if anyone enters the area.
- Do not operate machine barefooted or while wearing sandals. Always wear substantial footwear with good ankle support while mowing.
- Do not pull mower backwards unless absolutely necessary. Always look down and behind before and while moving backwards.
- Never direct discharged material toward anyone. Avoid discharging material against a wall or obstruction. Material may ricochet back toward the operator. Stop blade when crossing gravel surfaces.
- Do not operate the mower without proper guards, plates, grass catcher or other safety protective devices in place.
- See manufacturer's instructions for proper operation and installation of accessories. Only use accessories approved by the manufacturer.
- Stop the blade(s) when crossing gravel drives, walks, or roads.
- Never leave a running machine unattended.
- Stop the engine (motor) and wait until the blade comes to a complete stop before cleaning the machine, removing the grass catcher, or unclogging the discharge chute.
- 2 • Mow only in daylight or good artificial light.

- Do not operate the machine while under the influence of alcohol or drugs.
- Never operate machine in wet grass. Always be sure of your footing: keep a firm hold on the handle; walk, never run.
- Disengage the drive system, if so equipped, before starting the engine (motor).
- If the equipment should start to vibrate abnormally, stop the engine (motor) and check immediately for the cause. Vibration is generally a warning of trouble.
- Always wear eye protection when operating machine.
- Use extra care when approaching blind corners, shrubs, trees, or other objects that may obscure vision.
- When loading or unloading this machine, do not exceed the maximum recommended operation angle of 15°.
- Wear proper Personal Protective Equipment (PPE) while operating this machine, including (at a minimum) sturdy footwear, eye protection, and hearing protection. Do not mow in shorts or open toed footwear.
- Allow engine to cool before refueling.
- Never refuel the machine indoors.
- Never store the machine or fuel container where there is an open flame, spark or pilot light such as a water heater or on other appliances.
- Never fill containers inside a vehicle, on a truck or trailer bed with a plastic liner. Always place containers on the ground away from your vehicle before filling.
- Remove gas-powered equipment from the truck or trailer and refuel it on the ground. If this is not possible, then refuel such equipment with a portable container, rather than from a gasoline dispenser nozzle.
- Keep the nozzle in contact with the rim of the fuel tank or container opening at all times until fueling is complete. Do not use a nozzle lock-open device.
- If fuel is spilled on clothing, change clothing immediately.
- Never overfill fuel tank. Replace gas cap and tighten securely.

Always let someone know you are outside mowing.

III. SLOPE OPERATION

Slopes are a major factor related to slip & fall accidents, which can result in severe injury. All slopes require extra caution. If you feel uneasy on a slope, do not mow it.

DO:

- Mow across the face of slopes: never up and down. Exercise extreme caution when changing direction on slopes.
- Remove obstacles such as rocks, tree limbs, etc.
- Watch for holes, ruts, bumps or hidden objects. Uneven terrain could cause a slip and fall accident. Tall grass can hide obstacles.

DO NOT:

- Do not mow near drop-offs, ditches or embankments. You could lose your footing or balance.
- Do not mow on wet grass or excessively steep slopes. Poor footing could cause a slip and fall accident.

IV. SAFE HANDLING OF GASOLINE

To avoid personal injury or property damage, use extreme care in handling gasoline. Gasoline is extremely flammable and the vapors are explosive.

- Extinguish all cigarettes, cigars, pipes and other sources of ignition.
- Use only an approved container.
- Never remove gas cap or add fuel with the engine running.
- Never run a machine inside a closed area.
- Never make adjustments or repairs with the engine (motor) running. Disconnect the spark plug wire, and keep the wire away from the plug to prevent accidental starting.
- Keep all nuts and bolts tight to be sure the equipment is in safe working condition.
- Never tamper with safety devices. Check their proper operation regularly. Never do anything to interfere with the intended function of a safety device or reduce the protection provided by a safety device.
- Keep machine free of grass, leaves, or other debris build-up. Clean oil or fuel spillage. Allow machine to cool before storing.
- Stop and inspect the equipment if you strike an object. Repair, if necessary, before restarting.
- Never attempt to make wheel height adjustments while the engine is running.
- Grass catcher components are subject to wear, damage, and deterioration, which could expose moving parts or allow objects to be thrown. Frequently check components and replace with manufacturer's recommended parts, when necessary.
- Mower blades are sharp and can cut. Wrap the blade(s) or wear gloves, and use extra caution when servicing them.
- Do not change the engine governor setting or overspeed the engine.
- Maintain or replace safety and instruction labels, as necessary.

WARRANTY

GENERAL: Craftsman products are warranted to be free from defects in materials or workmanship for a specific time period as set-out below (the "Warranty Period"). Warranties extend to the original purchaser of a Craftsman product only. Purchases made through an online auction or through any website other than www.sears.ca are excluded. The relevant Warranty Period commences on the original date of purchase. Within this period, Sears Canada, Inc. will, at its sole option, repair or replace any products or components which fail in normal use. Such repairs or replacement will be made at no charge to the customer for parts or labor, provided that the customer shall be responsible for any transportation cost.

EXCLUSIONS: This warranty does not cover failures due to normal wear, abuse, misuse, neglect (including but not limited to the use of stale fuel, dirt, abrasives, moisture, rust, corrosion, or any adverse reaction due to improper storage or use habits), improper maintenance or failure to follow maintenance guidelines and/or instructions, failure to operate the product in accordance with the owner's manual or any additional instructions or information provided at the time of purchase or in subsequent communications with the original purchaser, accident or unauthorized alterations or repairs made or attempted by others. Also excluded from warranty coverage – except as provided below - are the following: maintenance, adjustments, components subject to wear including but not limited to: cosmetic components, belts, blades, blade adapters, bulbs, tires, filters, guide bars, lubricants, seats, grips, recoil assy's, saw chains and bars, trimmer lines and spools, spark plugs, starter ropers and tines, and discoloration resulting from ultraviolet light. Any product missing the model and/or serial number identification label will be disqualified from coverage under this warranty.

REPAIRS: Repairs have a 90 day warranty. If the defective product is still within the Warranty Period, then the new warranty is 90 days from the date of repair or to the end of the original Warranty Period, whichever period is longer.

DISCLAIMERS: THE WARRANTIES AND REMEDIES CONTAINED HEREIN ARE EXCLUSIVE AND IN LIEU OF ALL OTHER WARRANTIES, WHETHER ORAL OR WRITTEN (OTHER THAN AS STATED HEREIN), AND WHETHER EXPRESS, IMPLIED OR STATUTORY, INCLUDING BUT NOT LIMITED TO ANY. THIS WARRANTY GIVES YOU SPECIFIC LEGAL RIGHTS, WHICH MAY VARY FROM PROVINCE TO PROVINCE.

IN NO EVENT SHALL SEARS BE LIABLE FOR ANY INCIDENTAL, SPECIAL, INDIRECT OR CONSEQUENTIAL DAMAGES, WHETHER RESULTING FROM THE USE, MISUSE OR INABILITY TO USE THE PRODUCT OR FROM DEFECTS IN THE PRODUCT. THE EXCLUSIONS IN THIS PARAGRAPH SHALL NOT APPLY IN JURISDICTIONS WHERE APPLICABLE LAW DOES NOT ALLOW FOR THE EXCLUSION OF INCIDENTAL OR CONSEQUENTIAL DAMAGES. IN SUCH JURISDICTIONS, THIS PARAGRAPH SHALL NOT APPLY, BUT THE REMAINING PROVISIONS OF THIS DOCUMENT SHALL REMAIN VALID.

Sears retains the exclusive right to repair or replace the product or offer a full refund of the purchase price at its sole discretion. SUCH REMEDY SHALL BE YOUR SOLE AND EXCLUSIVE REMEDY FOR ANY BREACH OF WARRANTY.

CUSTOMER RESPONSIBILITIES: In addition to complying with all suggested maintenance guidelines and instructions, customers' obligations shall include but shall not be limited to: operating the product in accordance with the owner's manual or any additional instructions or information provided at the time of purchase or in subsequent communications to the purchaser from time to time, exhibit reasonable care in the use, operation, maintenance, general upkeep and storage of the product. Failure to comply with these requirements will void any applicable warranty.

WARRANTY

LIST OF APPLICABLE WARRANTY PERIODS: The following list contains the applicable Warranty Period for your Craftsman product and is based on a combination of the type of product or component and the intended and actual use of the product or component:

1. **90 DAYS:** Craftsman products intended for use or actually used for commercial, institutional, professional or income-producing purposes
2. **2 YEARS:** Craftsman riding lawn mowers, yard and garden tractors, walk behind mowers, tillers, brush cutters, snow blowers, handheld blowers, backpack blowers, hedge trimmers and electrical products for noncommercial, nonprofessional, non-institutional, or non-income-producing use, except for those components which are part of engine systems manufactured by third party engine manufacturers for which the purchase has received an separate warranty with product information supplied at the time of purchase.
3. **1 YEAR:** Craftsman power cutters, stump grinders, pole pruners, gas chain saws, electric chain saws, trimmer attachments, baggers and pole saws for noncommercial, nonprofessional, non-institutional, or non-income-producing use.
4. **90 DAYS:** All defective batteries, which will be replaced during this 90-day Warranty Period.
5. **60 DAYS:** Additional Warranty Period of 60 days will apply to adjustments and worn products or components **BUT DOES NOT INCLUDE WEAR OR ADJUSTMENTS** for products used for commercial, institutional, professional or income-producing purposes. Wear items include but are not limited to: belts, blades, tires, spark plugs, air filters, chains, shear bolts, skid plates, scraper bars, drift cutters, ropes, tines, collection bags and pulleys.

As the Warranty Period runs from the date of purchase and NOT from the date that a product is delivered, opened, assembled or first used, please ensure during this time period that your product or component has been assembled and tested for correction operation regardless of when you intend to actually use it. Claims made after the Warranty Period has expired will not be honored.

PROOF OF PURCHASE/DOCUMENTATION: Warranty coverage is conditioned upon the original purchaser furnishing Sears Canada or its authorized third party service provider if applicable, with the original sales receipt or other adequate written proof of the original purchase date and identification of the product. In the event that the original purchaser is unable to provide a copy of the original sales receipt, Sears Canada Inc. reserves the right to determine in its sole discretion what other written proof of the original purchase date and identification of the product is acceptable.

PRODUCT SPECIFICATIONS

Serial Number:	
Date of Purchase:	
Gasoline Capacity / Type:	1,8 Litres (Unleaded Regular)
Oil Capacity:	0,51 Litres
Oil Type (API SJ-SN):	SAE 30 (above 0°C/32°F); SAE 5W-30 (below 0°C/32°F)
Spark Plug:	Champion RC12YC (Gap: 0,5 mm)
Blade Bolt Torque:	35-40 ft. lbs. (47-54 Nm)
• The model and serial numbers will be found on a decal on the rear of the lawn mower housing. Record both serial number and date of purchase in space provided above.	

ASSEMBLY / PRE-OPERATION

Read these instructions and this manual in its entirety before you attempt to assemble or operate your new lawn mower.

IMPORTANT: This lawn mower is shipped WITHOUT OIL OR GASOLINE in the engine.

Your new lawn mower has been assembled at the factory with the exception of those parts left unassembled for shipping purposes. To ensure safe and proper operation of your lawn mower, all parts and hardware you assemble must be tightened securely. Use the correct tools as necessary to ensure proper tightness. All parts such as nuts, washers, bolts, etc., necessary to complete the assembly have been placed in the parts bag.

TO REMOVE MOWER FROM CARTON

1. Remove loose parts included with mower.
2. Cut down two end corners of carton and lay end panel down flat.
3. Remove all packing materials except padding between upper and lower handle and padding holding operator presence control bar to upper handle.
4. Roll lawn mower out of carton and check carton thoroughly for additional loose parts.

HOW TO SET UP YOUR MOWER TO UNFOLD HANDLE

IMPORTANT: Unfold handle carefully so as not to pinch or damage control cables.

1. Raise handles until lower handle section locks into place in mowing position.
2. Remove protective padding, raise upper handle section into place on lower handle and tighten both handle knobs.
3. Remove handle padding holding operator presence control bar to upper handle.

Your lawn mower handle can be adjusted for your mowing comfort. Refer to "ADJUST HANDLE" in the Service and Adjustments section of this manual.

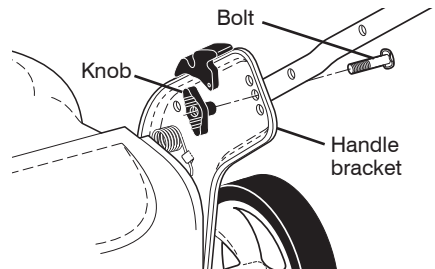
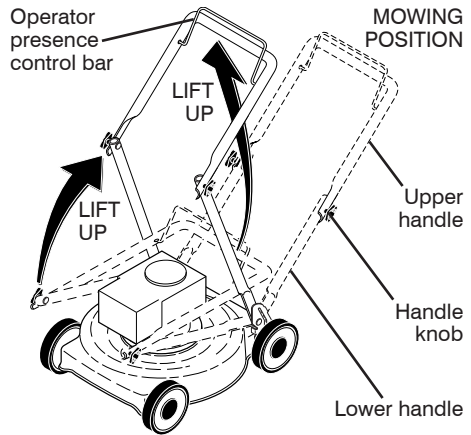

TO ASSEMBLE GRASS CATCHER

1. Put grass catcher frame into grass bag with rigid part of bag on the bottom. Make sure the frame handle is outside of the bag top.
 2. Slip vinyl bindings over frame.
- NOTE:** If vinyl bindings are too stiff, hold them in warm water for a few minutes. If bag gets wet, let it dry before using.

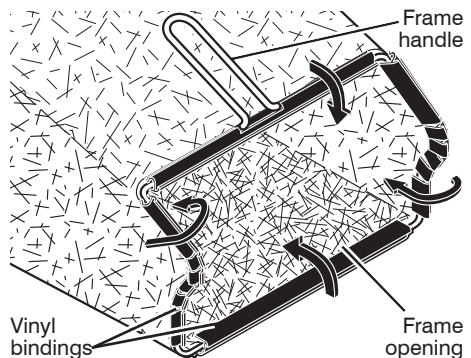

INSTALL STARTER ROPE

1. Loosen T-knob.
2. Hold control bar against upper handle.
3. Slowly pull engine starter rope out until rope will slip into loop of rope guide.
4. Tighten T-knob.

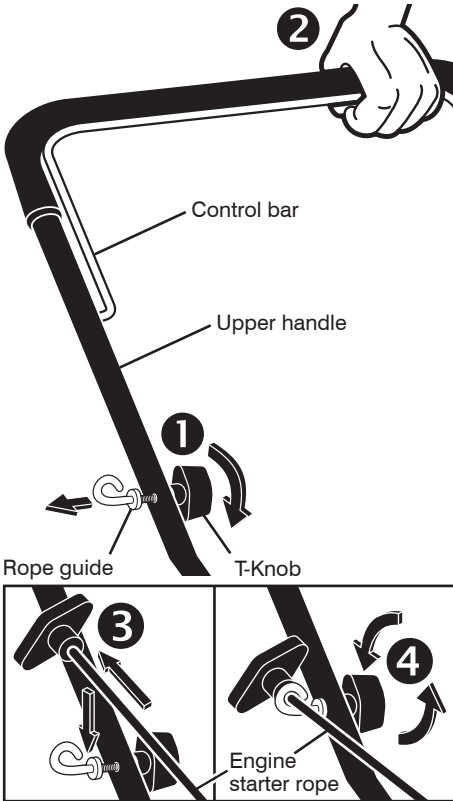

TO INSTALL ATTACHMENTS

Your lawn mower was shipped ready to be used as a mulcher. To convert mower to bagging or discharging, see "TO CONVERT MOWER" in the Operation section of this manual.

INTRODUCING THE PREMIUM BAGGING BLADE...

For people who bag their clippings, there is a new Premium Bagging Blade. This accessory provides:

- More efficient bagging
- Fewer clippings left on your lawn
- Better performance with leaves and heavy grass

When you want better bagging performance, simply remove your current blade and install the Premium Bagging Blade.

See "BLADE CARE" in the Maintenance section of this manual.

OPERATION

KNOW YOUR LAWN MOWER

READ THIS OWNER'S MANUAL AND ALL SAFETY RULES BEFORE OPERATING YOUR LAWN MOWER. Compare the illustrations with your lawn mower to familiarize yourself with the location of various controls and adjustments. Save this manual for future reference.

These symbols may appear on your lawn mower or in literature supplied with the product. Learn and understand their meaning.

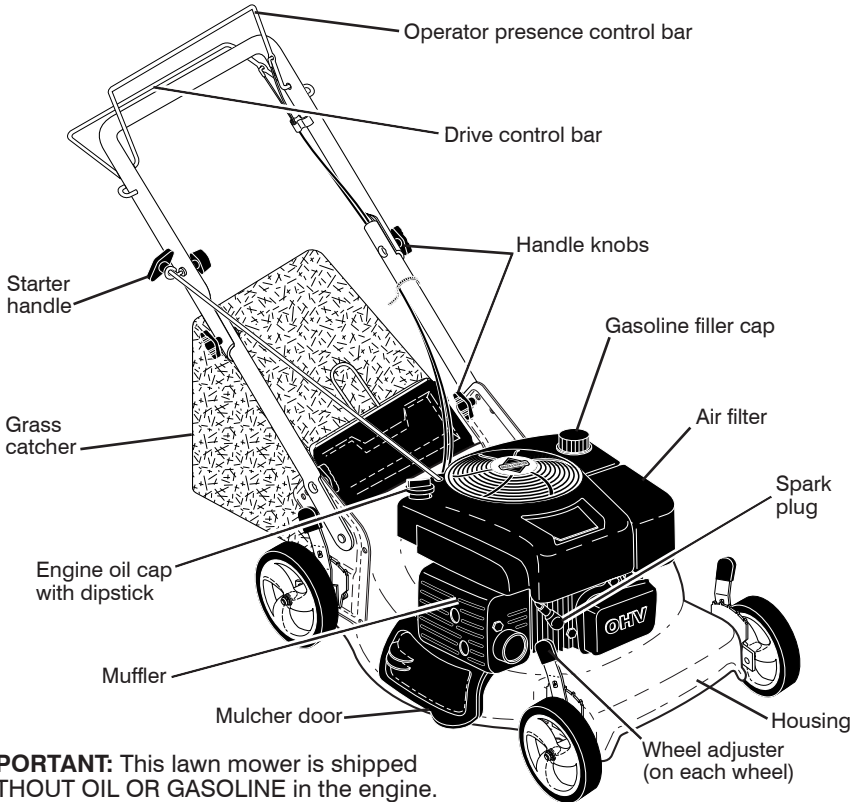
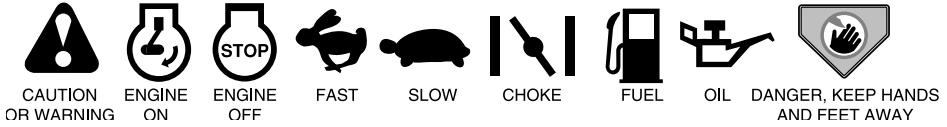

IMPORTANT: This lawn mower is shipped WITHOUT OIL OR GASOLINE in the engine.

NOTE: Gasoline containing up to 10% ethanol (E10) is acceptable for use in this machine. The use of any gasoline exceeding 10% ethanol (E10) will void the product warranty.

MEETS CPSC SAFETY REQUIREMENTS

Sears rotary walk-behind power lawn mowers conform to the safety standards of the American National Standards Institute and the U.S. Consumer Product Safety Commission. **⚠WARNING:** The blade turns when the engine is running.

Operator presence control bar – must be held down to the handle to start the engine. Release to stop the engine.

Primer– pumps additional fuel from the carburetor to the cylinder for use when starting a cold engine.

Starter handle – used for starting engine.

Drive control bar – used to engage power-propelled forward motion of mower.

Mulcher door – allows conversion to discharging or bagging operation.



The operation of any lawn mower can result in foreign objects thrown into the eyes, which can result in severe eye damage. Always wear safety glasses or eye shields while operating your lawn mower or performing any adjustments or repairs. We recommend standard safety glasses or a wide vision safety mask over spectacles.



Use ear protectors to avoid damage to hearing.

HOW TO USE YOUR LAWN MOWER ENGINE SPEED

Engine speed was set at the factory for optimum performance. It is not adjustable.

ENGINE ZONE CONTROL

CAUTION: Federal regulations require an engine control to be installed on this lawn mower in order to minimize the risk of blade contact injury. Do not under any circumstances attempt to defeat the function of the operator control. The blade turns when the engine is running.

- Your lawn mower is equipped with an operator presence control bar which requires the operator to be positioned behind the lawn mower handle to start and operate the lawn mower.

TO OPERATE DRIVE SYSTEM

- To start forward motion, lift drive control bar up to handle.
- To stop forward motion, release drive control bar.

IMPORTANT: Always keep drive control fully engaged against handle when in use.

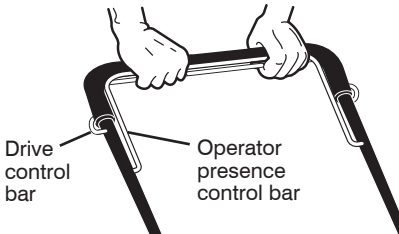

DRIVE CONTROL ENGAGED

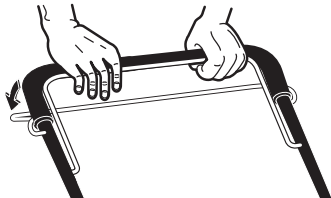

DRIVE CONTROL DISENGAGED

TO ADJUST CUTTING HEIGHT

Raise wheels for low cut and lower wheels for high cut, adjust cutting height to suit your requirements. Medium position is best for most lawns.

- To change cutting height, squeeze adjuster lever toward wheel. Move wheel up or down to suit your requirements. Be sure all wheels are in the same setting.

NOTE: Adjuster is properly positioned when plate tab inserts into hole in lever. Also, 9-position adjusters (if so equipped) allow lever to be positioned between the plate tabs.

ROTATE LEVER TOWARD ENGINE TO LOWER MOWER

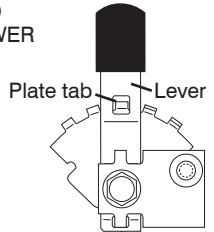
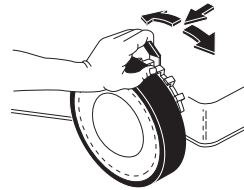

ROTATE LEVER AWAY FROM ENGINE TO RAISE MOWER

TO CONVERT MOWER

Your lawn mower was shipped ready to be used as a mulcher. To convert to bagging or discharging:

REAR BAGGING

- Lift rear door of the lawn mower and place the grass catcher frame hooks onto the grass bag brackets.
- To convert to mulching or discharging operation, remove grass catcher and close rear door.

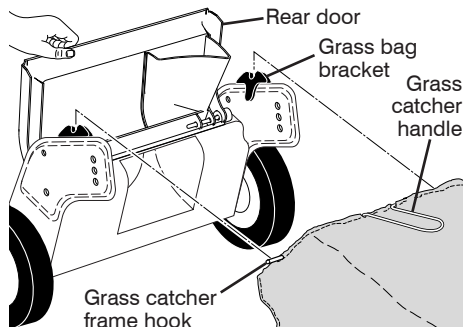

SIDE DISCHARGING

- Rear door must be closed.
- Open mulcher door and install discharge deflector under door as shown.
- Mower is now ready for discharging operation.
- To convert to mulching or bagging operation, discharge deflector must be removed and mulcher door must be closed and locked.

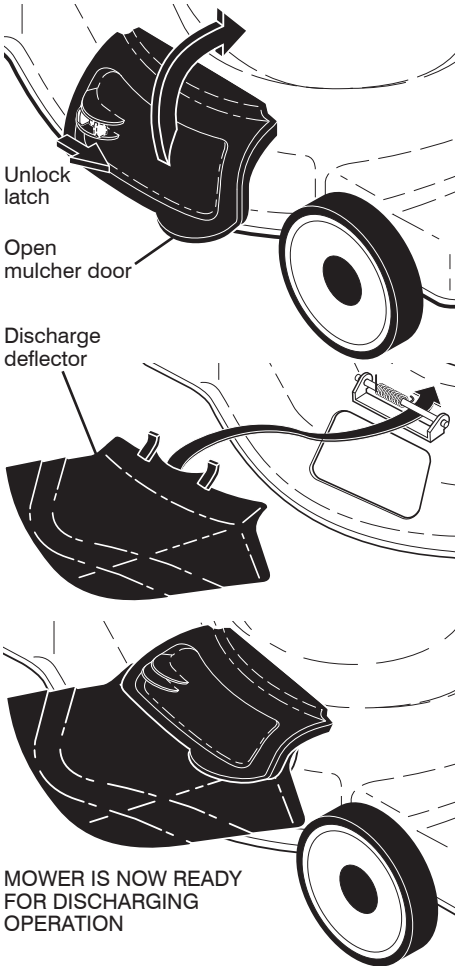

SIMPLE STEPS TO REMEMBER WHEN CONVERTING YOUR LAWN MOWER

FOR MULCHING -

1. Rear door closed.
2. Mulcher door closed and locked.

FOR REAR BAGGING -

1. Grass catcher installed.
2. Mulcher door closed and locked.

FOR SIDE DISCHARGING -

1. Rear door closed.
2. Discharge deflector installed.

⚠ CAUTION: Do not run your lawn mower without rear door closed or approved grass catcher in place. Never attempt to operate the lawn mower with the rear door removed or propped open.

TO EMPTY GRASS CATCHER

1. Lift up on grass catcher using the frame handle.
2. Remove grass catcher with clippings from under lawn mower handle.
3. Empty clippings from bag using both frame handle and bag handle.

NOTE: Do not drag the bag when emptying; it will cause unnecessary wear.

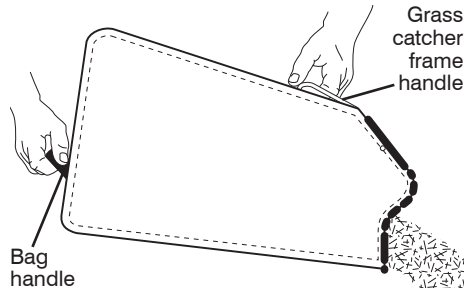

BEFORE STARTING ENGINE

ADD OIL

Your lawnmower is shipped without oil in the engine. For type and grade of oil to use, see "ENGINE" in the Maintenance section of this manual.

⚠ CAUTION: DO NOT overfill engine with oil, or it will smoke heavily from the muffler on startup.

1. Be sure lawnmower is level.
2. Remove oil dipstick from oil fill spout.
3. You receive a container of oil with the unit. Slowly pour the entire container down the oil fill spout into the engine.

NOTE: Initial oil fill requires only 18 oz. due to residual oil in engine from the manufacturers 100% quality testing. When changing oil you may need 20 oz.

4. Insert and tighten dipstick.

IMPORTANT:

- Check oil level before each use. Add oil if needed. Fill to full line on dipstick.
- Change the oil after every 25 hours of operation or each season. You may need to change the oil more often under dusty, dirty conditions. See "TO CHANGE ENGINE OIL" in the Maintenance section of this manual.

ADD GASOLINE

- Fill fuel tank to bottom of tank filler neck. Do not overfill. Use fresh, clean, regular unleaded gasoline with a minimum of 87 octane. Do not mix oil with gasoline. Purchase fuel in quantities that can be used within 30 days to assure fuel freshness.

⚠ CAUTION: Wipe off any spilled oil or fuel. Do not store, spill or use gasoline near an open flame.

⚠ CAUTION: Alcohol blended fuels (called gasohol or using ethanol or methanol) can attract moisture which leads to separation and formation of acids during storage. Acidic gas can damage the fuel system of an engine while in storage. To avoid engine problems, the fuel system should be emptied before storage of 30 days or longer. Empty the gas tank, start the engine and let it run until the fuel lines and carburetor are empty. Use fresh fuel next season. See Storage Instructions for additional information. Never use engine or carburetor cleaner products in the fuel tank or permanent damage may occur.

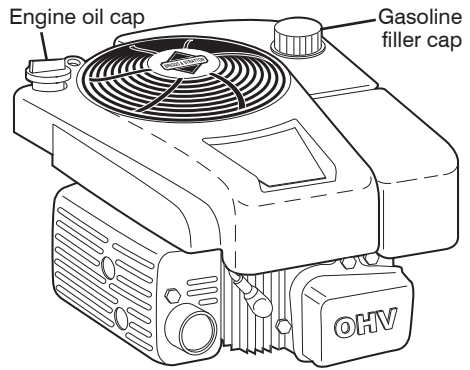

TO STOP ENGINE

- To stop engine, release operator presence control bar.

TO START ENGINE

NOTE: Due to protective coatings on the engine, a small amount of smoke may be present during the initial use of the product and should be considered normal.

NOTE: Your engine is equipped with an automatic choke system. No priming or choking is required before starting.

- To start engine, hold operator presence control bar down to the handle and pull starter handle quickly. Do not allow starter rope to snap back.

MOWING TIPS

⚠ CAUTION: Do not use de-thatcher blade attachments on your mower. Such attachments are hazardous, will damage your mower and could void your warranty.

- Under certain conditions, such as very tall grass, it may be necessary to raise the height of cut to reduce pushing effort and to keep from overloading the engine and leaving clumps of grass clippings. It may also be necessary to reduce ground speed and/or run the lawn mower over the area a second time.
- For extremely heavy cutting, reduce the width of cut by overlapping previously cut path and mow slowly.
- For side discharge operation, cut in a counterclockwise direction, starting at the outside of the area to be cut, in order to spread grass clippings more evenly and to put less load on the engine. To keep clippings off of walkways, flower beds, etc., make the first cuts in a clockwise direction.

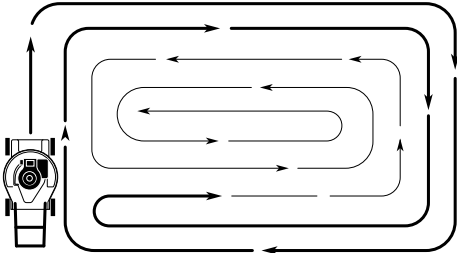

- If a trail of grass clipping is left on the right side of the lawn mower during rear discharge operation, mow in a clockwise direction with a small overlap to collect the clippings on the next pass.
- Pores in cloth grass catchers can become filled with dirt and dust with use and catchers will collect less grass. To prevent this, regularly hose catcher off with water and let dry before using.
- Keep top of engine around starter clear and clean of grass clippings and chaff. This will help engine air flow and extend engine life.

MULCHING MOWING TIPS

IMPORTANT: For best performance, keep mower housing free of built-up grass and trash. See “CLEANING” in the Maintenance section of this manual.

- The special mulching blade will recut the grass clippings many times and reduce them in size so that as they fall onto the lawn they will disperse into the grass and not be noticed. Also, the mulched grass will biodegrade quickly to provide nutrients for the lawn. Always mulch with your highest engine (blade) speed as this will provide the best recutting action of the blades.
- Avoid cutting your lawn when it is wet. Wet grass tends to form clumps and interferes with the mulching action. The best time to mow your lawn is the early afternoon. At this time the grass has dried, yet the newly cut area will not be exposed to direct sunlight.
- For best results, adjust the lawn mower cutting height so that the lawn mower cuts off only the top one-third of the grass blades. If the lawn is overgrown it will be necessary to raise the height of cut to reduce pushing effort and to keep from overloading the engine and leaving clumps of mulched grass. For extremely heavy grass, reduce your width of cut by overlapping previously cut path and mow slowly.

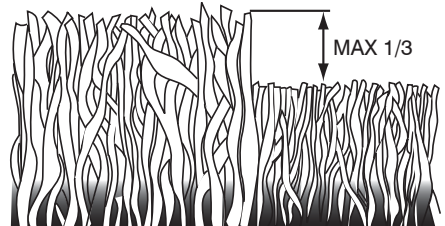

- Certain types of grass and grass conditions may require that an area be mulched a second time to completely hide the clippings. When doing a second cut, mow across (perpendicular) to the first cut path.
- Change your cutting pattern from week to week. Mow north to south one week then change to east to west the next week. This will help prevent matting and graining of the lawn.

MAINTENANCE

MAINTENANCE SCHEDULE		BEFORE EACH USE	AFTER EACH USE	EVERY 10 HOURS	EVERY 25 HOURS OR SEASON	EVERY 100 HOURS	BEFORE STORAGE
LAWN MOWER	Check for Loose Fasteners	✓					✓
	Clean / Inspect Grass Catcher *	✓	✓				✓
	Check Tires	✓					
	Check Drive Wheels ***	✓					
	Clean Lawn Mower ****		✓				✓
	Clean under Drive Cover ***			✓			
	Check Drive Belt / Pulleys ***				✓		
	Check / Sharpen / Replace Blade				✓ ₃		
	Lubrication				✓		
Clean and Recharge Battery **				✓		✓ ₄	
ENGINE	Check Engine Oil level	✓ ₅					
	Change Engine Oil				✓ _{1,2,6}		
	Clean Air Filter				✓ ₂		
	Inspect Muffler				✓		
	Replace Spark Plug					✓	
	Replace Air Filter Paper Cartridge					✓ ₂	
	Empty fuel system or add Stabilizer						✓

* (if so equipped)

** Electric-Start mowers

*** Power-Propelled mowers

**** Use a scraper to clean under deck

1 - Change more often if operating under a heavy load or in high outdoor temperatures.

2 - Service more often if operating in dirty or dusty conditions.

3 - Replace blades more often when mowing in sandy soil.

4 - Charge 48 hours at end of season.

5 - And after each 5 hours of use.

6 - See "LUBRICATION" in the Maintenance section of this manual.

GENERAL RECOMMENDATIONS

The warranty on this lawn mower does not cover items that have been subjected to operator abuse or negligence. To receive full value from the warranty, operator must maintain unit as instructed in this manual. Some adjustments will need to be made periodically to properly maintain your unit. At least once a season, check to see if you should make any of the adjustments described in the Service and Adjustments section of this manual.

- At least once a year, replace the spark plug, clean or replace air filter element and check blade for wear. A new spark plug and clean/new air filter element assure proper air-fuel mixture and help your engine run better and last longer.
- Follow the maintenance schedule in this manual.

BEFORE EACH USE

- Check engine oil level.
- Check for loose fasteners.

LUBRICATION

Keep unit well lubricated (See "LUBRICATION CHART").

LUBRICATION CHART

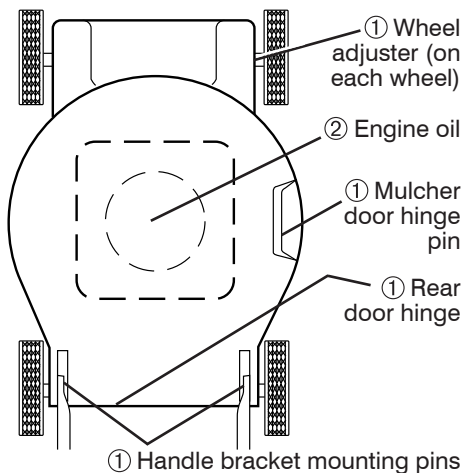

① Spray lubricant

② See "ENGINE" in Maintenance section.

IMPORTANT: Do not oil or grease plastic wheel bearings. Viscous lubricants will attract dust and dirt that will shorten the life of the self-lubricating bearings. If you feel they must be lubricated, use only a dry, powdered graphite type lubricant sparingly.

LAWN MOWER

Always observe safety rules when performing any maintenance.

TIRES

- Keep tires free of gasoline, oil, or insect control chemicals which can harm rubber.
- Avoid stumps, stones, deep ruts, sharp objects and other hazards that may cause tire damage.

DRIVE WHEELS

Check rear drive wheels each time you mow to be sure they move freely. The wheels not turning freely means trash, grass cuttings, etc., may be inside the drive wheel and dust cover area and must be cleaned out to free drive wheels. If necessary to clean the drive wheels, check both rear wheels.

BLADE CARE

For best results, mower blade must be kept sharp. Replace a bent or damaged blade.

⚠ CAUTION: Use only a replacement blade approved by the manufacturer of your mower. Using a blade not approved by the manufacturer of your mower is hazardous, could damage your mower and void your warranty.

TO REMOVE BLADE

1. Disconnect spark plug wire from spark plug and place wire where it cannot come in contact with plug.
2. Turn lawn mower on its side. Make sure air filter and carburetor are up.
3. Use a wood block between blade and mower housing to prevent blade from turning when removing blade bolt.

NOTE: Protect your hands with gloves and/or wrap with heavy cloth.

4. Remove blade bolt by turning counter-clockwise.
5. Remove blade and attaching hardware (bolt, lock washer, hardened washer).
6. Remove debris shield.

NOTE: Remove the blade adapter and check the key inside hub of blade adapter. The key must be in good condition to work properly. Replace adapter if damaged.

TO REPLACE BLADE

1. Position the blade adapter on the engine crankshaft. Be sure key in adapter and crankshaft keyway are aligned; and that the drive belt is inside the tab of the belt retainer.

2. Install debris shield.
 3. Position blade on the blade adapter.
IMPORTANT: To ensure proper assembly, center hole in blade must align with star on blade adapter.
 4. Be sure the trailing edge of blade (opposite sharp edge) is up toward the engine.
 5. Install the blade bolt with the lock washer and hardened washer into blade adapter and crankshaft.
 6. Use block of wood between blade and lawn mower housing and tighten the blade bolt, turning clockwise.
- The recommended tightening torque is 35–40 ft. lbs. (47–54 Nm).

IMPORTANT: Blade bolt is heat treated. If bolt needs replacing, replace only with approved bolt shown in the Repair Parts section of this manual.

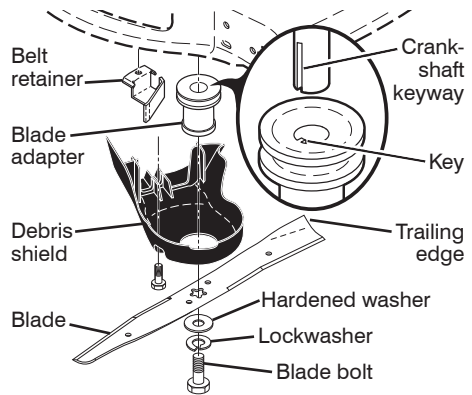

TO SHARPEN BLADE

NOTE: We do not recommend sharpening blade - but if you do, be sure the blade is balanced. An unbalanced blade will cause eventual damage to lawn mower or engine.

- The blade can be sharpened with a file or on a grinding wheel. Do not attempt to sharpen while on the mower.
- To check blade balance, you will need a 5/8" diameter steel bolt, pin, or a cone balancer. (When using a cone balancer, follow the instructions supplied with balancer.)

NOTE: Do not use a nail for balancing blade. The lobes of the center hole may appear to be centered, but are not.

- Slide blade on to an unthreaded portion of the steel bolt or pin and hold the bolt or pin parallel with the ground. If blade is balanced, it should remain in a horizontal position. If either end of the blade moves downward, sharpen the heavy end until the blade is balanced.

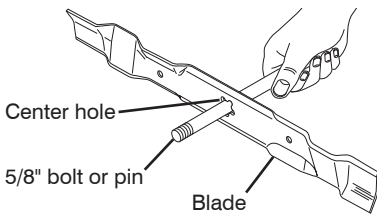

GRASS CATCHER

- The grass catcher may be hosed with water, but must be dry when used.
- Check your grass catcher often for damage or deterioration. Through normal use it will wear. If catcher needs replacing, replace only with approved replacement catcher shown in the Repair Parts section of this manual. Give the lawn mower model number when ordering.

GEAR CASE

- To keep your drive system working properly, the gear case and area around the drive should be kept clean and free of trash build-up. Clean under the drive cover twice a season.
- The gear case is filled with lubricant to the proper level at the factory. The only time the lubricant needs attention is if service has been performed on the gear case.

ENGINE

LUBRICATION

Use only high quality detergent oil rated with API service classification SJ–SN. Select the oil's SAE viscosity grade according to your expected operating temperature.

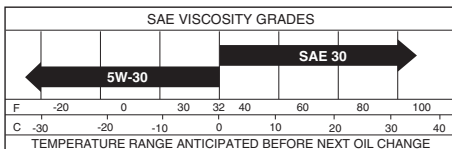

NOTE: Although multi-viscosity oils (5W30, 10W30 etc.) improve starting in cold weather, these multi-viscosity oils will result in increased oil consumption when used above 32°F. Check your engine oil level more frequently to avoid possible engine damage from running low on oil. Change the oil after every 25 hours of operation or at least once a year if the lawn mower is not used for 25 hours in one year.

Check the crankcase oil level before starting the engine and after each five (5) hours of continuous use. Tighten oil plug securely each time you check the oil level.

TO CHANGE ENGINE OIL

NOTE: Before tipping lawn mower to drain oil, empty fuel tank by running engine until fuel tank is empty.

1. Disconnect spark plug wire from spark plug and place wire where it cannot come in contact with plug.
2. Remove engine oil cap; lay aside on a clean surface.
3. Tip lawn mower on its side as shown and drain oil into a suitable container. Rock lawn mower back and forth to remove any oil trapped inside of engine.

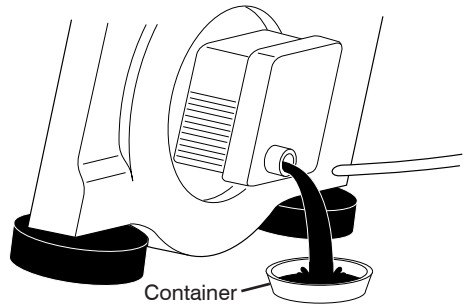

4. Wipe off any spilled oil from lawn mower or side of engine.
5. Slowly pour oil down the oil fill spout, stopping every few ounces to check the oil level with the dipstick.
6. Stop adding oil when you reach the FULL mark on the dipstick. Wait a minute to allow oil to settle.
7. Continue adding small amounts of oil, rechecking the dipstick until oil level settles at FULL. DO NOT overfill, or engine will smoke heavily from the muffler on startup.
8. Always be sure to retighten oil dipstick before starting engine.
9. Reconnect spark plug wire to spark plug.

AIR FILTER

Your engine will not run properly using a dirty air filter. Replace paper cartridge every 100 hours of operation or every season, whichever occurs first. Service air cleaner more often under dusty conditions.

1. Loosen screws and remove cover.
2. Carefully remove cartridge.
3. Clean by gently tapping on a flat surface. If very dirty, replace cartridge.

CAUTION: Petroleum solvents, such as kerosene, are not to be used to clean cartridge. They may cause deterioration of the cartridge. Do not oil cartridge. Do not use pressurized air to clean or dry cartridge.

4. Install cartridge, then replace cover.

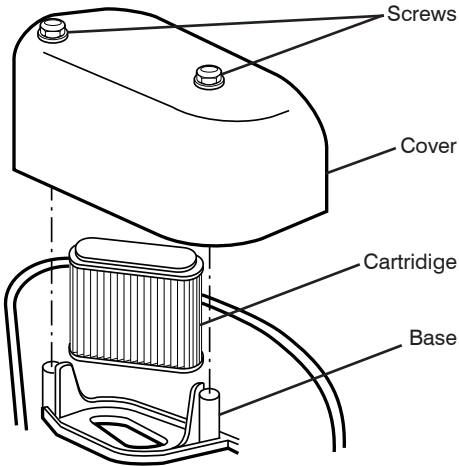

MUFFLER

Inspect and replace corroded muffler as it could create a fire hazard and/or damage.

SPARK PLUG

Replace spark plug at the beginning of each mowing season or after every 100 hours of operation, whichever occurs first. Spark plug type and gap setting are shown in the "PRODUCT SPECIFICATIONS" section of this manual.

CLEANING

IMPORTANT: For best performance, keep mower housing free of built-up grass and trash. Clean the underside of your mower after each use.

CAUTION: Disconnect spark plug wire from spark plug and place wire where it cannot come in contact with spark plug.

- Clean the underside of your lawn mower by scraping to remove build-up of grass and trash.
- Clean engine often to keep trash from accumulating. A clogged engine runs hotter and shortens engine life.
- Keep finished surfaces and wheels free of all gasoline, oil, etc.
- With the exception of the water wash-out port (if equipped), we do not recommend using a garden hose to clean the outside of your lawn mower unless the electrical system, muffler, air filter and carburetor are covered to keep water out. Water in engine can result in shortened engine life.

IN-LINE FUEL FILTER

The fuel filter should be replaced once each season. If fuel filter becomes clogged, obstructing fuel flow to carburetor, replacement is required.

1. With engine cool, remove filter and plug fuel line sections.
2. Place new fuel filter in position in fuel line with arrow pointing towards carburetor.
3. Be sure there are no fuel line leaks and clamps are properly positioned.
4. Immediately wipe up any spilled gasoline.

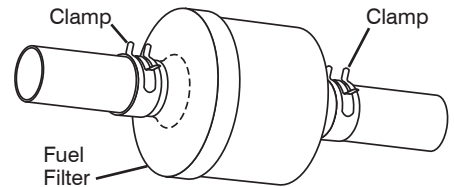

CLEAN UNDER DRIVE COVER

Clean under drive cover at least twice a season. Scrape underside of cover with putty knife or similar tool to remove any build-up of trash or grass on underside of drive cover.

SERVICE AND ADJUSTMENTS

⚠ WARNING: To avoid serious injury, before performing any service and adjustments:

1. Release control bar and stop engine.
2. Make sure the blade and all moving parts have completely stopped.
3. Disconnect spark plug wire from spark plug and place wire where it cannot come in contact with plug.

LAWN MOWER

TO ADJUST CUTTING HEIGHT

See "TO ADJUST CUTTING HEIGHT" in the Operation section of this manual.

REAR DEFLECTOR

The rear deflector, attached between the rear wheels of your mower, is provided to minimize the possibility that objects will be thrown out of the rear of the mower into the operator mowing position. If the deflector becomes damaged, it should be replaced.

TO REMOVE DRIVE BELT

1. Remove screws securing rear baffle.
2. Turn lawn mower on its side with air filter and carburetor up.
3. Remove rear baffle from mower.
4. Disconnect return spring from rear baffle / rear gearcase belt keeper.
5. Remove blade bolt, lockwasher, hardened washer and blade.
6. Remove debris shield.
7. Remove gearcase belt keeper.
8. Remove drive belt.

TO REPLACE DRIVE BELT

1. Place new drive belt on gearcase pulley.
NOTE: Always use factory approved belt to assure proper fit and long life.
2. Reinstall gearcase belt keeper. Be sure the new drive belt is inside the tabs of the gearcase belt keeper.
3. Position the blade adapter on the engine crankshaft. Be sure key in adapter and crankshaft keyway are aligned; and that the new drive belt is inside the tabs of the belt retainer.
4. Reattach return spring to rear baffle / rear gearcase belt keeper.
5. Place rear baffle in mower housing.
6. Reinstall debris shield.
7. Reinstall blade. The recommended tightening torque is 35–40 ft. lbs. (47–54 Nm).

8. Return mower to upright position.
9. Reinstall rear baffle screws.

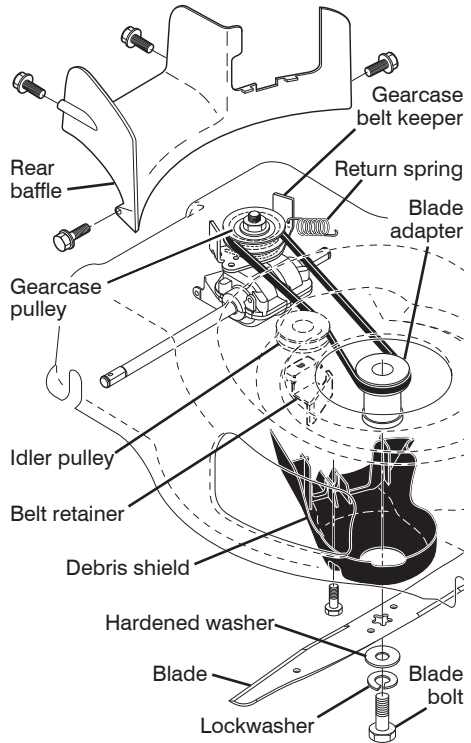

TO ADJUST HANDLE

Your handle has three (3) height positions - adjust to a height that suits you.

1. Remove knob and carriage bolt on one side of the lower handle.
2. While holding handle assembly, remove knob and carriage bolt from opposite side, align hole in handle with desired hole in handle bracket and reassemble bolt and knob and tighten securely.
3. Align opposite side of handle with same positioning hole and secure with bolt and knob.

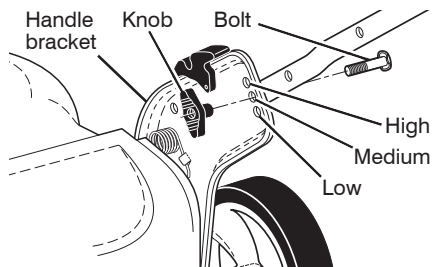

ENGINE

ENGINE SPEED

Your engine speed has been factory set.

CARBURETOR

Your carburetor is not adjustable.

IMPORTANT: Never tamper with the engine governor, which is factory set for proper engine speed. Overspeeding the engine above the factory high speed setting can be dangerous. If you think the engine-governed high speed needs adjusting, contact a Sears or other qualified service center, which has proper equipment and experience to make any necessary adjustments.

STORAGE

Immediately prepare your lawn mower for storage at the end of the season or if the unit will not be used for 30 days or more.

LAWN MOWER

When lawn mower is to be stored for a period of time, clean it thoroughly, remove all dirt, grease, leaves, etc. Store in a clean, dry area.

1. Clean entire lawn mower (See "CLEANING" in the Maintenance section of this manual).
2. Lubricate as shown in the Maintenance section of this manual.
3. Be sure that all nuts, bolts, screws, and pins are securely fastened. Inspect moving parts for damage, breakage and wear. Replace if necessary.
4. Touch up all rusted or chipped paint surfaces; sand lightly before painting.

HANDLE

You can fold your handle for storage.

1. Loosen the two (2) handle knobs on sides of the upper handle and allow handle to fold down to the rear.
 2. Remove the two (2) handle knobs and carriage bolts on sides of the lower handle and pivot entire handle assembly forward and allow it to rest on mower.
 3. Reinstall knobs and carriage bolts to lower handle / handle brackets for safe keeping.
- When setting up your handle from the storage position, lower handle will require manually locking into mowing position.

IMPORTANT: When folding the handle for storage or transportation, be sure to fold the handle as shown or you may damage the control cables.

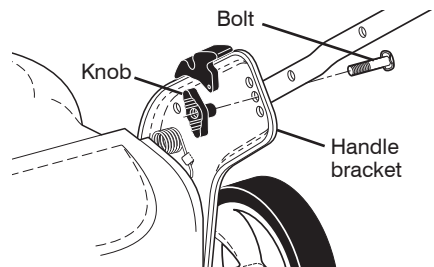
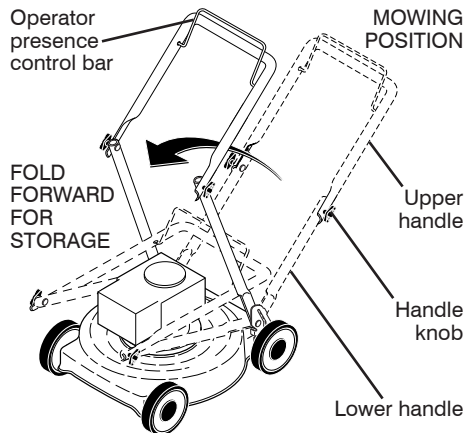

ENGINE

FUEL SYSTEM

IMPORTANT: It is important to prevent gum deposits from forming in essential fuel system parts such as carburetor, fuel filter, fuel hose, or tank during storage. Alcohol blended fuels (called gasohol or using ethanol or methanol) can attract moisture which leads to separation and formation of acids during storage. Acidic gas can damage the fuel system of an engine while in storage.

- Empty the fuel tank by starting the engine and letting it run until the fuel lines and carburetor are empty.
- Never use engine or carburetor cleaner products in the fuel tank or permanent damage may occur.
- Use fresh fuel next season.

NOTE: Fuel stabilizer is an acceptable alternative in minimizing the formation of fuel gum deposits during storage. Add stabilizer to gasoline in fuel tank or storage container. Always follow the mix ratio found on stabilizer container. Run engine at least 10 minutes after adding stabilizer to allow the stabilizer to reach the carburetor. Do not empty the gas tank and carburetor if using fuel stabilizer.

ENGINE OIL

Drain oil (with engine warm) and replace with clean engine oil. (See “ENGINE” in the Maintenance section of this manual).

CYLINDER

1. Remove spark plug.
2. Pour one ounce (29 ml) of oil through spark plug hole into cylinder.
3. Pull starter handle slowly a few times to distribute oil.
4. Replace with new spark plug.

OTHER

- Do not store gasoline from one season to another.
- Replace your gasoline can if your can starts to rust. Rust and/or dirt in your gasoline will cause problems.
- If possible, store your unit indoors and cover it to protect it from dust and dirt.
- Cover your unit with a suitable protective cover that does not retain moisture. Do not use plastic. Plastic cannot breathe, which allows condensation to form and will cause your unit to rust.

IMPORTANT: Never cover mower while engine and exhaust areas are still warm.

CAUTION: Never store the lawn mower with gasoline in the tank inside a building where fumes may reach an open flame or spark. Allow the engine to cool before storing in any enclosure.

TROUBLESHOOTING - See appropriate section in manual unless directed to a Sears Parts & Repair Centre.

PROBLEM	CAUSE	CORRECTION
Does not start	<ol style="list-style-type: none"> 1. Dirty air filter. 2. Out of fuel. 3. Stale fuel. 4. Water in fuel. 5. Spark plug wire is disconnected. 6. Bad spark plug. 7. Loose blade or broken blade adapter. 8. Control bar in released position. 9. Control bar defective. 10. Fuel valve lever (if so equipped) in OFF position. 11. Weak battery (if equipped). 12. Disconnected battery connector (if equipped). 13. Blown fuse (if equipped). 	<ol style="list-style-type: none"> 1. Clean/replace air filter. 2. Fill fuel tank. 3. Empty fuel tank and refill tank with fresh, clean gasoline. 4. Empty fuel tank and refill tank with fresh, clean gasoline. 5. Connect wire to plug. 6. Replace spark plug. 7. Tighten blade bolt or replace blade adapter. 8. Depress control bar to handle. 9. Replace control bar. 10. Turn fuel valve lever to the ON position. 11. Charge battery. 12. Connect battery to engine. 13. Replace fuse.

TROUBLESHOOTING - See appropriate section in manual unless directed to a Sears Parts & Repair Centre.

PROBLEM	CAUSE	CORRECTION
Loss of power	<ol style="list-style-type: none"> 1. Rear of lawn mower housing or cutting blade dragging in heavy grass. 2. Cutting too much grass. 3. Dirty air filter. 4. Buildup of grass, leaves, and trash under mower. 5. Too much oil in engine. 6. Walking speed too fast. 	<ol style="list-style-type: none"> 1. Raise cutting height. 2. Raise cutting height. 3. Clean/replace air filter. 4. Clean underside of mower housing. 5. Check oil level. 6. Cut at slower walking speed.
Poor cut – uneven	<ol style="list-style-type: none"> 1. Worn, bent or loose blade. 2. Wheel heights uneven. 3. Buildup of grass, leaves and trash under mower. 	<ol style="list-style-type: none"> 1. Replace blade. Tighten blade bolt. 2. Set all wheels at same height. 3. Clean underside of mower housing.
Excessive vibration	<ol style="list-style-type: none"> 1. Worn, bent or loose blade. 2. Bent engine crankshaft. 	<ol style="list-style-type: none"> 1. Replace blade. Tighten blade bolt. 2. Contact a Sears or other qualified service centre.
Starter rope hard to pull	<ol style="list-style-type: none"> 1. Engine flywheel brake is on when control bar is released. 2. Bent engine crankshaft. 3. Blade adapter broken. 4. Blade dragging in grass. 	<ol style="list-style-type: none"> 1. Depress control bar to upper handle before pulling starter rope. 2. Contact a Sears or other qualified service centre. 3. Replace blade adapter. 4. Move lawn mower to cut grass or to hard surface.
Grass catcher not filling (If so equipped)	<ol style="list-style-type: none"> 1. Cutting height too low. 2. Lift on blade worn off. 3. Catcher not venting air. 	<ol style="list-style-type: none"> 1. Raise cutting height. 2. Replace blade. 3. Clean grass catcher.
Hard to push	<ol style="list-style-type: none"> 1. Grass is too high or wheel height is too low. 2. Rear of lawn mower housing or cutting blade dragging in grass. 3. Grass catcher too full. 4. Handle height position not right for you. 	<ol style="list-style-type: none"> 1. Raise cutting height. 2. Raise rear of lawn mower housing one (1) setting higher. 3. Empty grass catcher. 4. Adjust handle height to suit.
Loss of drive or slowing of drive speed	<ol style="list-style-type: none"> 1. Belt wear. 2. Belt off of pulley. 3. Drive cable worn or broken. 4. "Loose" drive control system. 	<ol style="list-style-type: none"> 1. Check/replace drive belt. 2. Check/reinstall drive belt. 3. Replace drive cable. 4. Adjust drive control.

CRAFTSMAN ROTARY LAWN MOWER -- MODEL NUMBER 944.364741

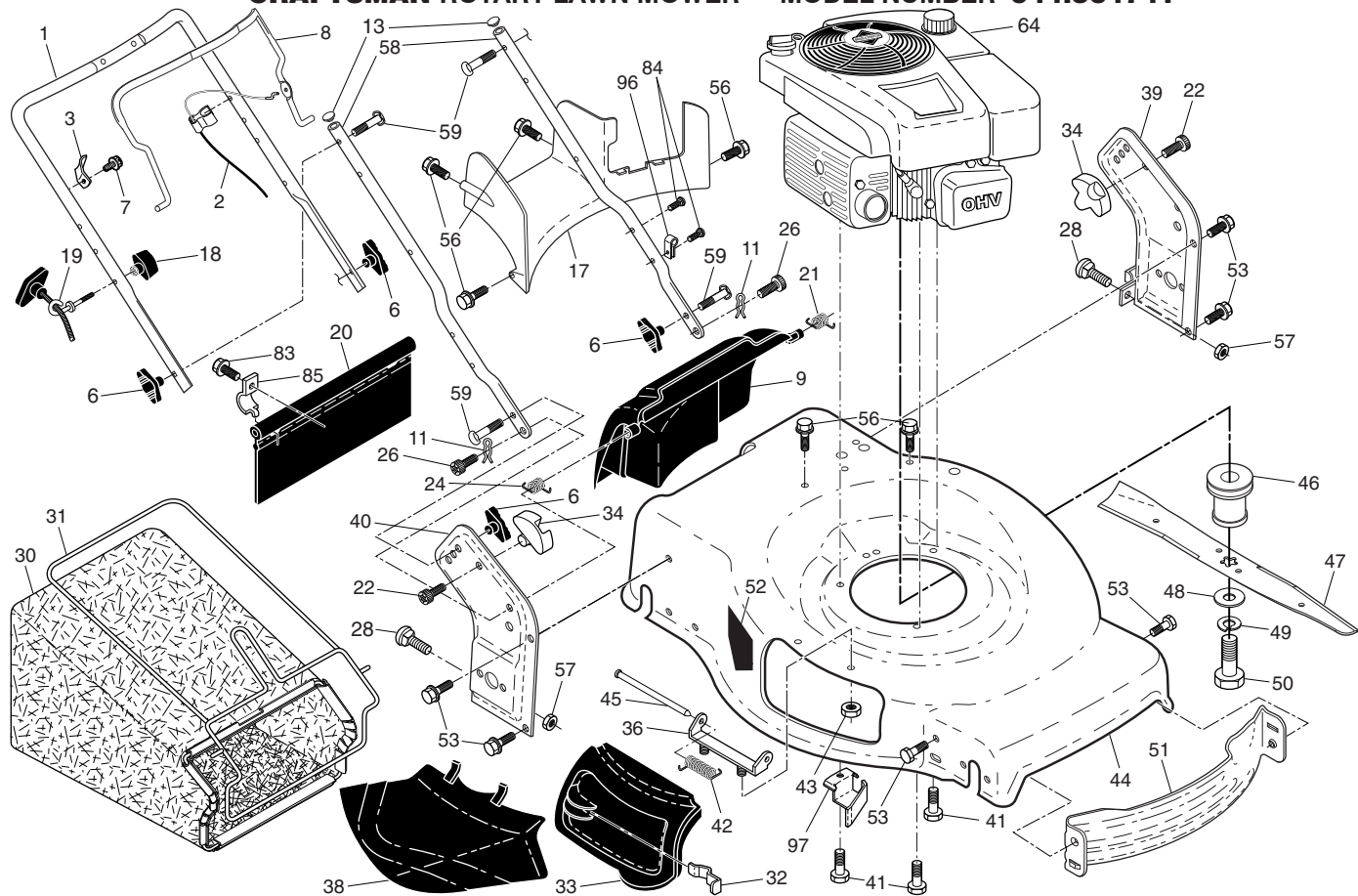

CRAFTSMAN ROTARY LAWN MOWER - - MODEL NUMBER 944.364741

KEY NO.	PART NO.	DESCRIPTION	KEY NO.	PART NO.	DESCRIPTION	KEY NO.	PART NO.	DESCRIPTION
1	585864805	Upper Handle Assembly	30	580947303	Grassbag	50	851084	Screw, Machine, Hex Head
2	440385	Cable, Engine Zone Control	31	585054703	Frame, Grass Catcher			3/8-24 x 1-3/8 Grade 8
3	429930X004	Bracket, Upstop	32	419944X007	Latch, Mulcher Door	51	430599	Front Baffle
6	189713X428	Handle Knob	33	420019	Mulcher Door	52	404763	Decal, Danger
7	178848	Screw, Hex Washer Head #10-16 x 5/8	34	419946X615	Bracket, Grassbag	53	17000510	Screw
8	427612X428	Control Bar	36	175735	Hinge Bracket Assembly	56	17411312	Screw, Hex Washer Head #13 x 3/4
9	581747804	Rear Door Assembly	38	419942X428	Discharge Deflector	57	155377	Nut, Hex
11	425575	Hairpin, Door/Handle Pivot	39	585900702	Handle Bracket, LH	58	585908202	Lower Handle
13	437516	Plug, Handle Bar	40	585900802	Handle Bracket, RH	59	191574	Handle Bolt
17	581782101	Rear Baffle	41	150406	Screw, Dogpoint 3/8-16 x 1-1/8	64	---	Engine, Briggs & Stratton, Model Number 110P02- 0003-F4 (See Breakdown)
18	581912601	T-Knob	42	193000	Spring, Torsion			Screw, Hex Washer Head
19	581902101	Rope Guide	43	191730	Nut, Hex, Nylock	83	750097	Fastener, Push
20	444501	Rear Skirt	44	586601601	Kit, Lawn Mower Housing	84	428124	Mounting Bracket, Skirt
21	419949	Spring, Rear Door, LH, Black	45	175650	Rod, Hinge	85	429801X004	Clip, Cable
22	141841	Screw, Panhead, Torx #20	46	581851501	Blade Adapter / Pulley	96	197991	Bracket
24	419948	Spring, Rear Door, RH, Grey	47	586179801	Blade, 22", Standard Mulching	97	581115302	Bag of Parts (Includes Key Numbers 6 and 59)
26	419945	Screw, Rear Door / Handle Pivot		580244001	Blade, 22", Premium Bagging	--	423849	Owner's Manual, English
28	586212501	Bolt, Carriage 5/16-18 x 5/8	48	851074	Washer, Hardened	--	587734527	Owner's Manual, French
			49	850263	Washer, Helical	--	587734531	

NOTE: All component dimensions given in U.S. inches. 1 inch = 25.4 mm.

IMPORTANT: Use only Original Equipment Manufacturer (O.E.M.) replacement parts. Failure to do so could be hazardous, damage your lawn mower and void your warranty.

CRAFTSMAN ROTARY LAWN MOWER -- MODEL NUMBER 944.364741

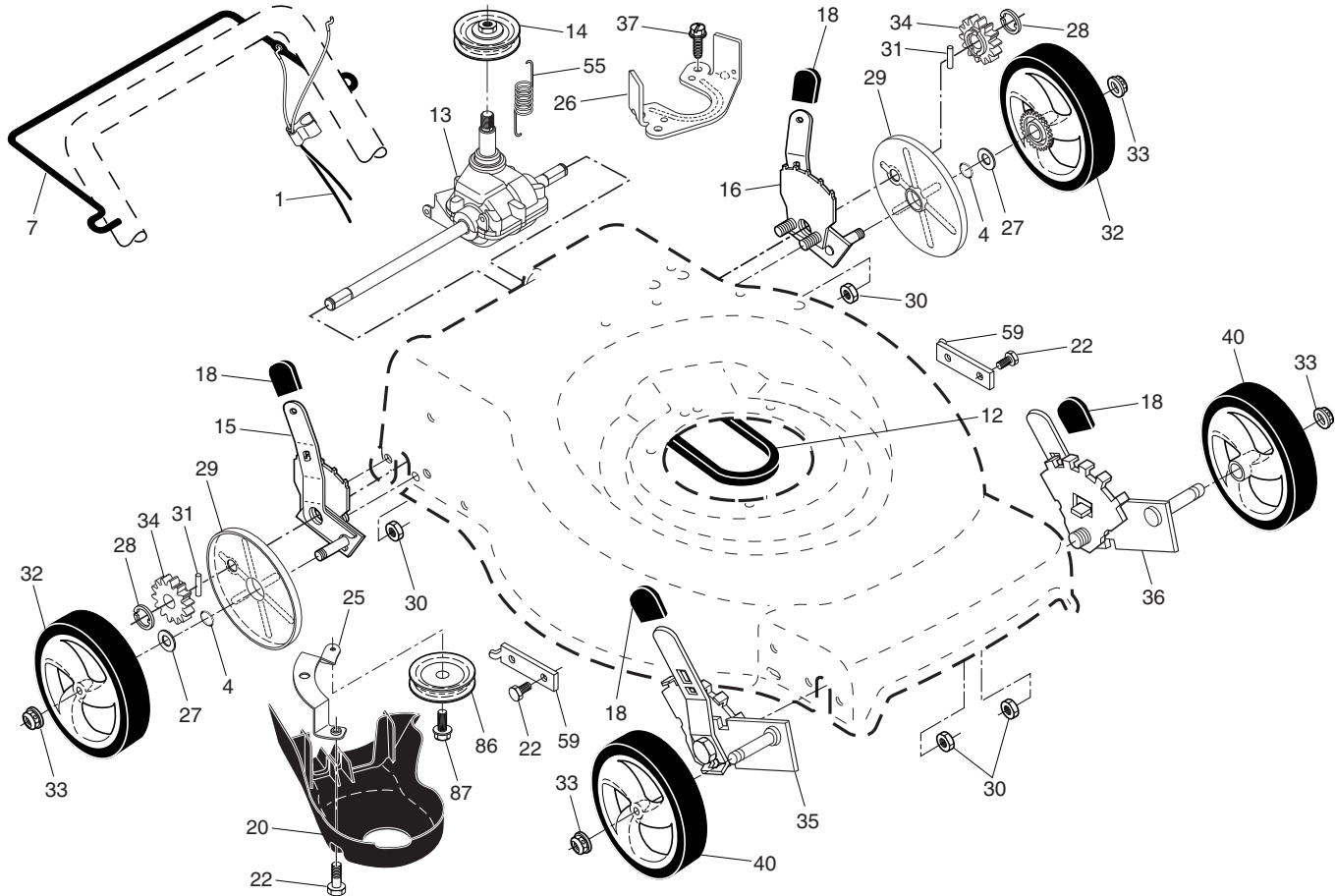

CRAFTSMAN ROTARY LAWN MOWER - - MODEL NUMBER 944.364741

KEY NO.	PART NO.	DESCRIPTION	KEY NO.	PART NO.	DESCRIPTION
1	586033302	Drive Control Assembly (Includes Cable)	28	12000058	E-Ring 7/16
4	197480	O-Ring	29	581840401	Cover, Dust, Wheel
7	194185X615	Control Bar, Drive	30	191730	Nut, Hex
12	580364604	Belt, Drive	31	404845	Pawl, Drive
13	581975507	Gear Case Assembly, Complete	32	581685301	Wheel & Tire Assembly, Rear
14	586963001	Pulley, Drive	33	409148	Nut, Flangelock 3/8-16
15	581497908	Wheel Adjuster, Rear, RH	34	404835	Pinion
16	581497907	Wheel Adjuster, Rear, LH	35	431138	Wheel Adjuster, Front, RH
18	701037	Selector Knob	36	431139	Wheel Adjuster, Front, LH
20	580806901	Debris Shield	37	163409	Screw, Hi-Lo Thread
22	17000510	Screw, Hex Head 5/16-18	40	400246X460	Wheel & Tire Assembly, Front
25	581313802	Mounting Bracket, Debris Shield	55	581351301	Spring, Return
26	421516X004	Bracket, Gearcase	59	441786X004	Support Bracket
27	67725	Washer	86	587969201	Pulley, Idler
			87	581127601	Screw

NOTE: All component dimensions given in U.S. inches. 1 inch = 25.4 mm.

IMPORTANT: Use only Original Equipment Manufacturer (O.E.M.) replacement parts. Failure to do so could be hazardous, damage your lawn mower and void your warranty.

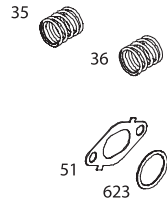
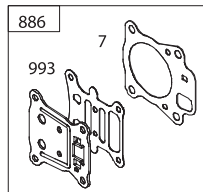
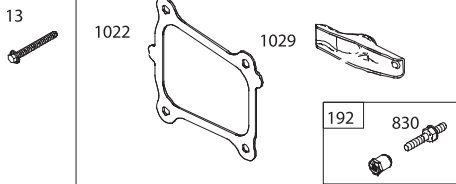
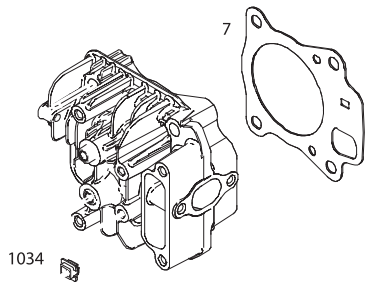
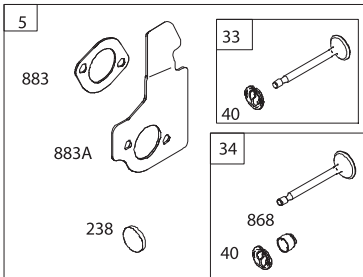
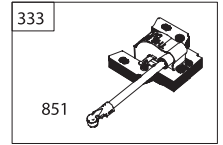
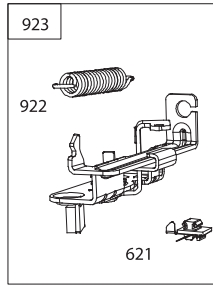
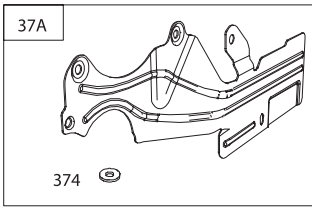
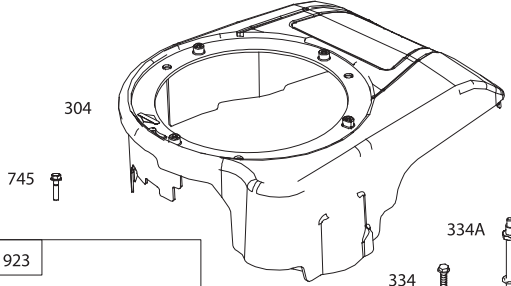
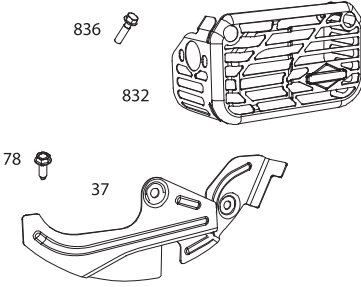
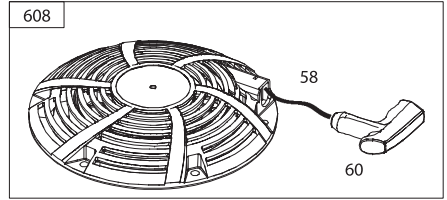
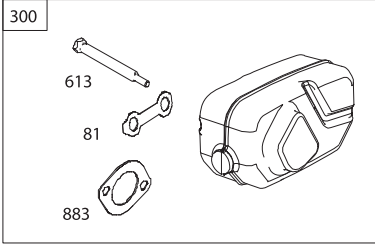

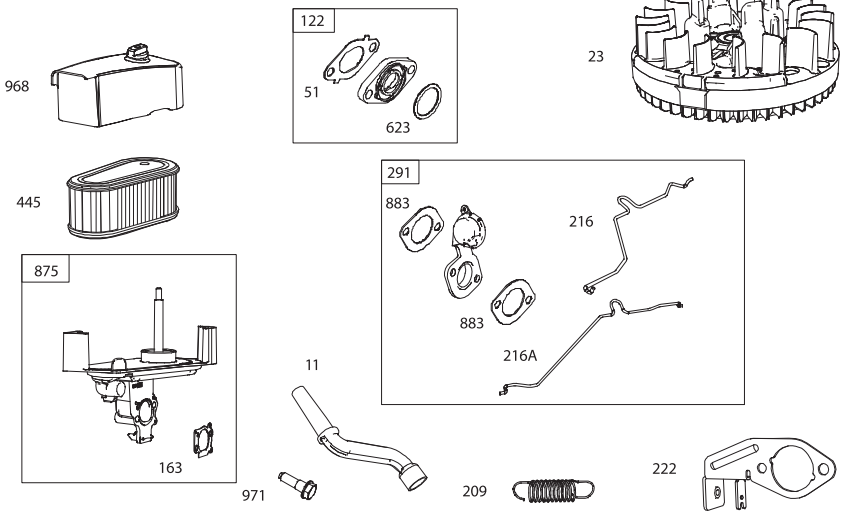
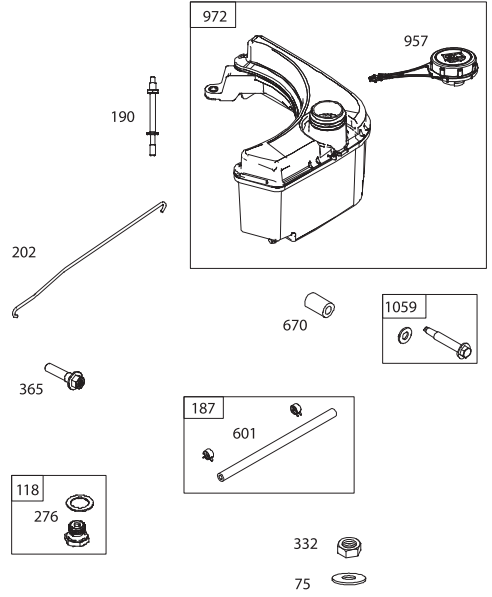
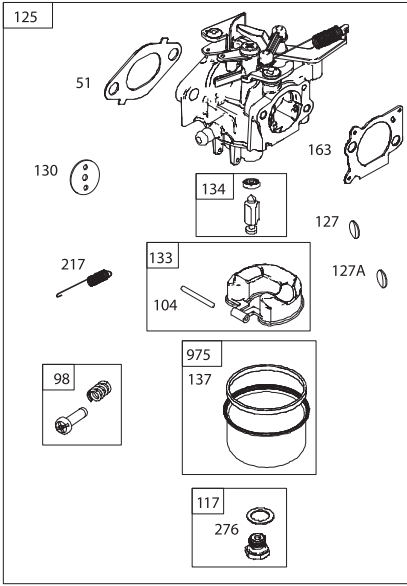

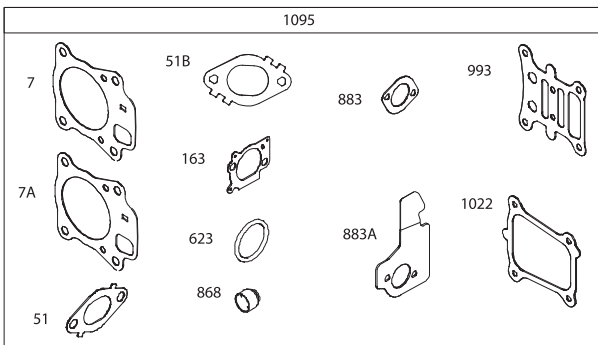
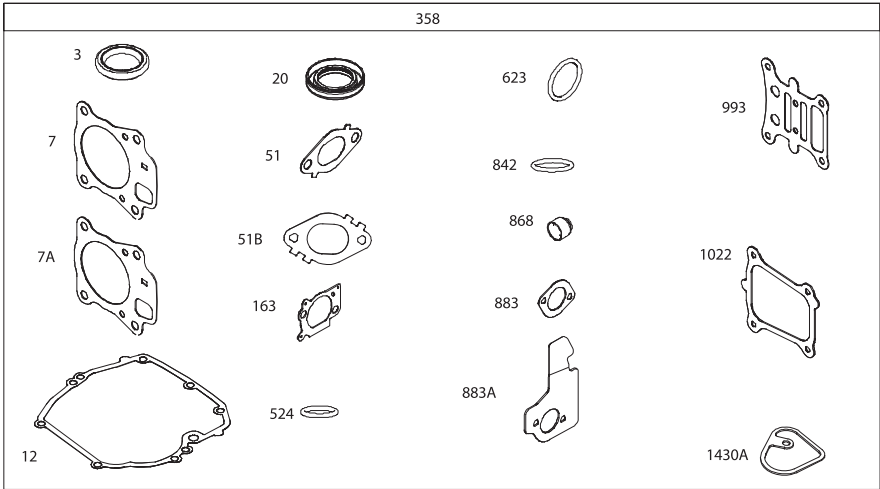
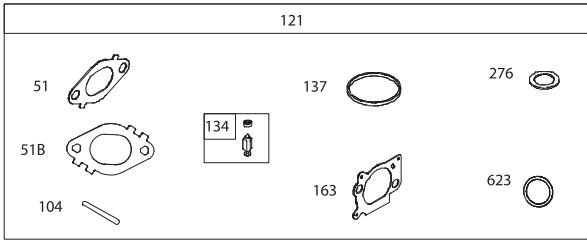

Engine Power Rating Information

The gross power rating for individual gas engine models is labeled in accordance with SAE (Society of Automotive Engineers) code J1940 (Small Engine Power & Torque Rating Procedure), and rating performance has been obtained and corrected in accordance with SAE J1995 (Revision 2002-05). Torque values are derived at 3060 RPM; horsepower values are derived at 3600 RPM. Actual gross engine power will be lower and is affected by, among other things, ambient operating conditions and engine-to-engine variability. Given both the wide array of products on which engines are placed and the variety of environmental issues applicable to operating the equipment, the gas engine will not develop the rated gross power when used in a given piece of power equipment (actual "on-site" or net power). This difference is due to a variety of factors including, but not limited to, accessories (air cleaner, exhaust, charging, cooling, carburetor, fuel pump, etc.), application limitations, ambient operating conditions (temperature, humidity, altitude), and engine-to-engine variability. Due to manufacturing and capacity limitations, Briggs & Stratton may substitute an engine of higher rated power for this Series engine.

KEY NO.	PART NO.	DESCRIPTION	KEY NO.	PART NO.	DESCRIPTION
1	798948	Cylinder Assembly	48	N/A	Short Block (Not Available At This Printing)
3	299819s	Seal-Oil (Magneto Side)			
4	493279	Sump-Engine	51	796596	Gasket-Intake
5	796471	Head-Cylinder	51B	592159	Gasket-Intake
7	796475	Gasket-Cylinder Head	58	697316	Rope-Starter
7A	799275	Gasket-Cylinder Head (Fire Ring)	60	799716	Grip-Starter Rope
			75	691736	Washer (Flywheel)
11	796478	Tube-Breather	78	793480	Screw (Flywheel Guard)
12	692232	Gasket-Crankcase	81	691740	Lock-Muffler Screw
13	793451	Screw (Cylinder Head)	89	692348	Plug (Cylinder)
15	691680	Plug-Oil Drain	98	797156	Kit-Idle Speed
16	796468	Crankshaft	104	797622	Pin-Float Hinge
20	399781s	Seal-Oil (PTO Side)	117	799604	Jet-Main (Standard)
22	691092	Screw (Crankcase Cover/Sump)	118	799227	Jet-Main (High Altitude) (5000 > 9000 Feet)
23	590420	Flywheel	121	592172	Kit-Carburetor Overhaul
24	222698s	Key-Flywheel (Aluminum)	122	796595	Spacer-Carburetor
25	796643	Piston Assembly (Standard)	125	593380	Carburetor
	796644	Piston Assembly (.020" Oversize)	127	694468	Plug-Welch (Diameter = 9.5mm)
26	796645	Ring Set (Standard)	127A	797633	Plug-Welch (Diameter = 7.9mm)
	796646	Ring Set (.020" Oversize)	130	797630	Valve-Throttle
27	691588	Lock-Piston Pin	133	797626	Float-Carburetor
28	298909	Pin-Piston	134	799177	Kit-Needle/Seat
29	796470	Rod-Connecting	137	797625	Gasket-Float Bowl
32	691664	Screw (Connecting Rod) (1/4-20 x 1.09)	163	691894	Gasket-Air Cleaner
32A	695759	Screw (Connecting Rod) (1/4-20 x 1.5)	187	791766	Line-Fuel (Cut to Required Length)
33	499642	Valve-Exhaust	190	793479	Screw (Fuel Tank)
34	795443	Valve-Intake	192	796631	Adjuster-Rocker Arm
35	691304	Spring-Valve (Intake)	202	796657	Link-Mechanical Governor
36	691304	Spring-Valve (Exhaust)	209	796483	Spring-Governor (Black)
37	590921	Guard-Flywheel (Carburetor Side)	216	798944	Link-Choke
37A	799155	Guard-Flywheel (Muffler Side)	216A	796485	Link-Choke
			217	799179	Spring-Choke Return
40	692194	Retainer-Valve	222	796482	Bracket-Control
43	796650	Slinger-Governor/Oil	227	796487	Lever-Governor Control
45	690977	Tappet-Valve	238	691300	Cap-Valve
46	694039	Camshaft	276	797632	Washer-Sealing
			287	793479	Screw (Dipstick Tube)
			291	798938	Thermostat

KEY NO.	PART NO.	DESCRIPTION	KEY NO.	PART NO.	DESCRIPTION
300	798940	Muffler	868	795440	Seal-Valve
304	799647	Housing-Blower	875	796492	Base-Air Cleaner
332	690662	Nut (Flywheel)	883	793497	Gasket-Exhaust
333	592335	Armature-Magneto	883A	796677	Gasket-Exhaust
334	793454	Screw (Magneto Armature) (M6x27mm)	886	796474	Gasket Kit-Cylinder/Plate
334A	796537	Screw (Magneto Armature)	914	794451	Screw (Rocker Cover)
337	591039	Plug-Spark	922	692135	Spring-Brake
356	692390	Wire-Stop	923	796634	Brake
358	592173	Gasket Set-Engine	957	799585	Cap-Fuel Tank
365	793458	Screw (Carburetor) (M6x27mm)	968	796493	Cover-Air Cleaner
374	690402	Washer (Camshaft)	971	690349	Screw (Air Cleaner Base to Carburetor)
404	690272	Washer (Governor Crank)	972	590949	Tank-Fuel
445	795066	Filter-Air Cleaner Cartridge	975	797631	Bowl-Fuel
505	793515	Nut (Governor Control Lever)	993	796473	Gasket-Cylinder Head Plate
523	796503	Dipstick	1022	796480	Gasket-Rocker Cover
524	692296	Seal- Dipstick Tube	1023	796479	Cover-Rocker
525	796502	Tube-Dipstick	1026	796481	Rod-Push (Intake and Exhaust)
562	793514	Bolt (Governor Control Lever)	1029	691230	Arm-Rocker
592	793481	Nut (Rewind Starter)	1034	691343	Guide-Push Rod
598	592587	Shim-Endplay (Crankshaft)	1036	- - -	Label-Emissions (Available from any Briggs & Stratton Authorized Dealer)
601	791850	Clamp-Hose (Green)	1058	279946	Operator's Manual
608	796497	Starter-Rewind	1059	793471	Kit-Screw/Washer (Fuel Tank)
613	796496	Screw (Muffler)	1095	592174	Gasket Set-Valve
615	690340	Retainer-Governor Shaft	1263	697124	Reed -Breather
616	798327	Crank-Governor	1264	793453	Screw (Breather Reed)
621	692310	Switch-Stop	1329	N/A	Replacement Engine (Not Available At This Printing)
623	793628	Seal-O Ring (Carburetor Spacer)	1330	279000	Repair Manual
635	66538s	Boot-Spark Plug	1375	796476	Cover-Breather/Reed
670	793485	Spacer-Fuel Tank	1376	794451	Screw (Breather/Reed Cover)
718	690959	Pin-Locating	1430A	799494	Gasket (Breather/Reed)
741	797521	Gear-Timing	--	398067	Spark Arrester (available accessory)
745	793491	Screw (Brake)	NOTE: All component dimensions given in U.S. inches. 1 inch = 25.4 mm		
830	796472	Stud-Rocker Arm			
832	593411	Guard-Muffler			
836	793500	Screw (Muffler Guard)			
842	691031	Seal-O Ring (Dipstick Tube)			
847	796501	Dipstick/Tube Assembly			
851	493880s	Terminal-Spark Plug			

Get it fixed, at your home or ours!

Just Call:

1-800-4-MY-HOME[®]

(1-800-469-4663)

24 hours a day, 7 days a week

For the repair of major brand appliances **in your own home...**
no matter who made it, no matter who sold it!

For your nearest **Sears Parts and Service** location,
to bring in products like vacuums, lawn equipment and electronics.

For **Sears Parts & Service**, to order the replacement parts,
accessories and owner's manuals that you need to do-it-yourself.

www.sears.ca

To purchase or inquire about a Sears Maintenance Agreement, call:

1-800-361-6665

9 a.m. – 11 p.m. Mon. – Fri., EST, 9 a.m. – 4 p.m. Sat.

Pour service en français:

1-800-LE-FOYER^{MC}

(1-800-533-6937)

www.sears.ca



[®] / TM Trademarks of Sears, Roebuck and Co. used under license by Sears Canada

^{MD} Marque déposée / ^{MC} Marque de commerce de Sears, Roebuck and Co. utilisée en vertu d'une licence de Sears Canada